

Lenovo ideapad 320

ideapad 320-15ISK/ideapad 320H-15ISK/
ideapad 320L-15ISK/ideapad 320R-15ISK/
ideapad 320E-15ISK/ideapad 320-15IKB/
ideapad 320H-15IKB/ideapad 320L-15IKB/
ideapad 320R-15IKB/ideapad 320E-15IKB/
ideapad 320-15IKB Touch

Hardware

Maintenance

Manual

The Lenovo logo is positioned in the bottom right corner of the page. It consists of the word "Lenovo" in a white, sans-serif font, oriented vertically within a black rectangular background. A small trademark symbol (TM) is located at the top right of the word.

Lenovo™

Note:

- Before using this information and the product it supports, be sure to read the general information under “Notices” on page 79.

First Edition (March 2017)

© Copyright Lenovo 2017. All rights reserved.

LIMITED AND RESTRICTED RIGHTS NOTICE: If data or software is delivered pursuant a General Services Administration “GSA” contract, use, reproduction, or disclosure is subject to restrictions set forth in Contract No. GS-35F-05925.

© 2017 Lenovo

Contents

About this manual	iv	FRU replacement notices	31
Safety information	1	Screw notices	31
General safety	2	Removing and replacing an FRU	32
Electrical safety	3	1010 Optical drive	33
Safety information	3	1020 Base cover	34
Safety inspection guide	5	1030 Battery pack	37
Handling devices that are sensitive to electrostatic discharge	6	1040 PCI Express Mini Card for wireless LAN	39
Grounding requirements	6	1050 DIMM	41
Safety notices: multilingual translations	7	1060 Hard disk drive	42
Laser compliance statement	14	1070 Speakers	44
Important service information	16	1080 Fan assembly and Heat Sink assembly	45
Strategy for replacing FRUs	16	1090 ODD transfer board, backup battery and Fingerprint board	49
Strategy for replacing a hard disk drive	17	1100 Upper case	51
Important notice for replacing a system board	17	1110 System board	54
Important information about replacing RoHS compliant FRUs	18	1120 LCD unit	56
General checkout	19	1130 Integrated camera and antenna assembly	61
What to do first	20	Locations	62
Power system checkout	21	Front view and right-side view	62
Checking the AC adapter	21	Bottom and Left-side view	63
Checking operational charging	22	Parts list	64
Checking the battery pack	22	Overall	65
Related service information	23	LCD FRUs	74
Restoring the factory contents by using OneKey Recovery	23	Miscellaneous parts	76
Restore of factory default	23	AC adapters	76
Passwords	24	Screws	78
Power-on password	24	Notices	79
Hard-disk password	24	Trademarks	80
Administrator password	24		
Power management	25		
Screen blank state	25		
Putting the computer to sleep or shutting it down	25		
Putting your computer to sleep	25		
Shutting down the computer	26		
Lenovo ideapad 320-15ISK/ideapad 320H-15ISK/ideapad 320L-15ISK/ideapad 320R-15ISK/ideapad 320E-15ISK/ideapad 320-15IKB/ideapad 320H-15IKB/ideapad 320L-15IKB/ideapad 320R-15IKB/ideapad 320E-15IKB/ideapad 320-15IKB Touch	27		
Specifications	27		
Status indicators	29		
Hotkeys	30		

About this manual

This manual contains service and reference information for the following Lenovo product:

**Lenovo ideapad 320-15ISK/ideapad 320H-15ISK/ideapad 320L-15ISK/
ideapad 320R-15ISK/ideapad 320E-15ISK/ideapad 320-15IKB/ideapad
320H-15IKB/ideapad 320L-15IKB/ideapad 320R-15IKB/ideapad
320E-15IKB/ideapad 320-15IKB Touch**

Use this manual to troubleshoot problems.

The manual is divided into the following sections:

- The common sections provide general information, guidelines, and safety information required for servicing computers.
- The product-specific section includes service, reference, and product-specific parts information.

Important:

This manual is intended only for trained servicers who are familiar with Lenovo products. Use this manual to troubleshoot problems effectively.

Before servicing a Lenovo product, make sure to read all the information under “Safety information” on page 1 and “Important service information” on page 16.

Safety information

This chapter presents the following safety information that you need to get familiar with before you service a Lenovo ideapad 320-15ISK/ideapad 320H-15ISK/ideapad 320L-15ISK/ideapad 320R-15ISK/ideapad 320E-15ISK/ideapad 320-15IKB/ideapad 320H-15IKB/ideapad 320L-15IKB/ideapad 320R-15IKB/ideapad 320E-15IKB/ideapad 320-15IKB Touch computer:

- “General safety” on page 2
- “Electrical safety” on page 3
- “Safety inspection guide” on page 5
- “Handling devices that are sensitive to electrostatic discharge” on page 6
- “Grounding requirements” on page 6
- “Safety notices: multilingual translations” on page 7
- “Laser compliance statement” on page 14

General safety

Follow these rules below to ensure general safety:

- Observe a good housekeeping in the area where the machines are put during and after the maintenance.
- When lifting any heavy object:
 1. Make sure that you can stand safely without slipping.
 2. Distribute the weight of the object equally between your feet.
 3. Use a slow lifting force. Never move suddenly or twist when you attempt to lift it.
 4. Lift it by standing or pushing up with your leg muscles; this action could avoid the strain from the muscles in your back. Do not attempt to lift any object that weighs more than 16 kg (35 lb) or that you think is too heavy for you.
- Do not perform any action that causes hazards to the customer, or that makes the machine unsafe.
- Before you start the machine, make sure that other service representatives and the customer are not in a hazardous position.
- Please remove covers and other parts in a safe place, away from all personnel, while you are servicing the machine.
- Keep your toolcase away from walk areas so that other people will not trip over it.
- Do not wear loose clothing that can be trapped in the moving parts of the machine. Make sure that your sleeves are fastened or rolled up above your elbows. If your hair is long, fasten it.
- Insert the ends of your necktie or scarf inside clothing or fasten it with the nonconductive clip, about 8 centimeters (3 inches) from the end.
- Do not wear jewelry, chains, metal-frame eyeglasses, or metal fasteners for your clothing.

Attention: Metal objects are good electrical conductors.
- Wear safety glasses when you are hammering, drilling, soldering, cutting wire, attaching springs, using solvents, or working in any other conditions that may be hazardous to your eyes.
- After service, reinstall all safety shields, guards, labels, and ground wires. Replace any safety device that is worn or defective.
- Reinstall all covers correctly before returning the machine to the customer.
- Fan louvers on the machine help to prevent the overheating of internal components. Do not obstruct fan louvers or cover them with labels or stickers.

Electrical safety

Observe the following rules when working on electrical equipments.

Important:

Use only approved tools and test equipments. Some hand tools have handles covered with a soft material that does not insulate you when working with live electrical currents.

Many customers have rubber floor mats near their machines that contain small conductive fibers to decrease electrostatic discharges. Do not use such kind of mat to protect yourself from electrical shock.

- Find the room emergency power-off (EPO) switch, disconnecting switch or electrical outlet. If an electrical accident occurs, you can then operate the switch or unplug the power cord quickly.
- Do not work alone under hazardous conditions or near the equipment that has hazardous voltages.
- Disconnect all power before:
 - Performing a mechanical inspection
 - Working near power supplies
 - Removing or installing main units
- Before you start to work on the machine, unplug the power cord. If you cannot unplug it, ask the customer to power-off the wall box that supplies power to the machine, and to lock the wall box in the off position.
- If you need to work on a machine that has exposed electrical circuits, observe the following precautions:
 - Ensure that another person, familiar with the power-off controls, is near you.

Attention: Another person must be there to switch off the power, if necessary.
 - Use only one hand when working with powered-on electrical equipment; keep the other hand in your pocket or behind your back.

Attention: An electrical shock can occur only when there is a complete circuit. By observing the above rule, you may prevent a current from passing through your body.
 - When using testers, set the controls correctly and use the approved probe leads and accessories for that tester.
 - Stand on suitable rubber mats (obtained locally, if necessary) to insulate you from grounds such as metal floor strips and machine frames.

Observe the special safety precautions when you work with very high voltages; instructions for these precautions are in the safety sections of maintenance information. Be extremely careful when you measure the high voltages.

- Regularly inspect and maintain your electrical hand tools for safe operational condition.
- Do not use worn or broken tools and testers.
- Never assume that power has been disconnected from a circuit. First, check it to make sure that it has been powered off.

- Always look carefully for possible hazards in your work area. Examples of these hazards are moist floors, nongrounded power extension cables, power surges, and missing safety grounds.
- Do not touch live electrical circuits with the reflective surface of a plastic dental mirror. The surface is conductive; such touching can cause personal injury and machine damage.
- Do not service the following parts with the power on when they are removed from their normal operating places in a machine:
 - Power supply units
 - Pumps
 - Blowers and fans
 - Motor generatorsand similar units. (This practice ensures correct grounding of the units.)
- If an electrical accident occurs:
 - Caution: do not become a victim yourself.
 - Switch off the power.
 - Send the victim to get medical aid.

Safety inspection guide

The purpose of this inspection guide is to assist you in identifying potential unsafe conditions. As each machine was designed and built, required safety items were installed to protect users and service personnel from injury. This guide addresses only those items. You should use good judgment to identify potential safety hazards according to the attachment of non-Lenovo features or options not covered by this inspection guide.

If any unsafe conditions are present, you must determine how serious the apparent hazard could be and whether you can continue without first correcting the problem.

Consider these conditions and the safety hazards they present:

- Electrical hazards, especially primary power (primary voltage on the frame can cause serious or fatal electrical shock)
- Explosive hazards, such as a damaged CRT face or a bulging capacitor
- Mechanical hazards, such as loose or missing hardware

To determine whether there are any potential unsafe conditions, use the following checklist at the beginning of every service task. Begin the checks with the power off, and the power cord disconnected.

Checklist:

1. Check exterior covers for damage (loose, broken, or sharp edges).
2. Turn off the computer. Disconnect the power cord.
3. Check the power cord for:
 - a. A third-wire ground connector in good condition. Use a meter to measure third-wire ground continuity for 0.1 ohm or less between the external ground pin and the frame ground.
 - b. The power cord should be the type specified in the parts list.
 - c. Insulation must not be frayed or worn.
4. Check for cracked or bulging batteries.
5. Remove the cover.
6. Check for any obvious non-Lenovo alterations. Use good judgment as to the safety of any non-Lenovo alterations.
7. Check inside the unit for any obvious unsafe conditions, such as metal filings, contamination, water or other liquids, or signs of fire or smoke damage.
8. Check for worn, frayed, or pinched cables.
9. Check that the power-supply cover fasteners (screws or rivets) have not been removed or tampered with.

Handling devices that are sensitive to electrostatic discharge

Any computer part containing transistors or integrated circuits (ICs) should be considered sensitive to electrostatic discharge (ESD). ESD damage can occur when there is a difference in charge between objects. Protect against ESD damage by equalizing the charge so that the machine, the part, the work mat, and the person handling the part are all at the same charge.

Notes:

1. Use product-specific ESD procedures when they exceed the requirements noted here.
2. Make sure that the ESD protective devices you use have been certified (ISO 9000) as fully effective.

When handling ESD-sensitive parts:

- Keep the parts in protective packages until they are inserted into the product.
- Avoid contact with other people.
- Wear a grounded wrist strap against your skin to eliminate static on your body.
- Prevent the part from touching your clothing. Most clothing is insulative and retains a charge even when you are wearing a wrist strap.
- Use the black side of a grounded work mat to provide a static-free work surface. The mat is especially useful when handling ESD-sensitive devices.
- Select a grounding system, such as those listed below, to provide protection that meets the specific service requirement.

Note:

The use of a grounding system to guard against ESD damage is desirable but not necessary.

- Attach the ESD ground clip to any frame ground, ground braid, or green-wire ground.
- When working on a double-insulated or battery-operated system, use an ESD common ground or reference point. You can use coax or connector-outside shells on these systems.
- Use the round ground prong of the ac plug on ac-operated computers.

Grounding requirements

Electrical grounding of the computer is required for operator safety and correct system function. Proper grounding of the electrical outlet can be verified by a certified electrician.

Safety notices: multilingual translations

The safety notices in this section are provided in English, French, German, Hebrew, Italian, Japanese, and Spanish.

Safety notice 1

Before the computer is powered on after FRU replacement, make sure all screws, springs, and other small parts are in place and are not left loose inside the computer. Verify this by shaking the computer and listening for rattling sounds. Metallic parts or metal flakes can cause electrical shorts.

Avant de remettre l'ordinateur sous tension après remplacement d'une unité en clientèle, vérifiez que tous les ressorts, vis et autres pièces sont bien en place et bien fixées. Pour ce faire, secouez l'unité et assurez-vous qu'aucun bruit suspect ne se produit. Des pièces métalliques ou des copeaux de métal pourraient causer un court-circuit.

Bevor nach einem FRU-Austausch der Computer wieder angeschlossen wird, muß sichergestellt werden, daß keine Schrauben, Federn oder andere Kleinteile fehlen oder im Gehäuse vergessen wurden. Der Computer muß geschüttelt und auf Klappergeräusche geprüft werden. Metallteile oder-splitter können Kurzschlüsse erzeugen.

לפני הפעלת המחשב לאחר החלפת FRU יש לוודא שכל הברגים, הקפיצים, וחלקים קטנים אחרים נמצאים במקומם ואינם חופשיים לזוז בתוך המחשב. כדי לוודא זאת, יש לטלטל את המחשב ולהקשיב לגילגולי קולות שקשוק. חלקי או שבבי מתכת עלולים לגרום לקצרים חשמליים.

Prima di accendere l'elaboratore dopo che é stata effettuata la sostituzione di una FRU, accertarsi che tutte le viti, le molle e tutte le altri parti di piccole dimensioni siano nella corretta posizione e non siano sparse all'interno dell'elaboratore. Verificare ciò scuotendo l'elaboratore e prestando attenzione ad eventuali rumori; eventuali parti o pezzetti metallici possono provocare cortocircuiti pericolosi.

FRUの交換後、コンピュータの電源を入れる前に、ねじ、バネ、その他の小さな部品がすべて正しい位置にあり、またコンピュータの内部で緩んでいないことを確認してください。これを確認するには、コンピュータを振って、カチャカチャと音がしないか確かめます。金属部品や金属破片はショートの原因になることがあります。

Antes de encender el sistema despues de sustituir una FRU, compruebe que todos los tornillos, muelles y demás piezas pequeñas se encuentran en su sitio y no se encuentran sueltas dentro del sistema. Compruébelo agitando el sistema y escuchando los posibles ruidos que provocarían. Las piezas metálicas pueden causar cortocircuitos eléctricos.

Safety notice 2

DANGER

Some standby batteries contain a small amount of nickel and cadmium. Do not disassemble a standby battery, recharge it, throw it into fire or water, or short-circuit it. Dispose of the battery as required by local ordinances or regulations. Use only the battery in the appropriate parts listing. Use of an incorrect battery can result in ignition or explosion of the battery.

Certaines batteries de secours contiennent du nickel et du cadmium. Ne les démontez pas, ne les rechargez pas, ne les exposez ni au feu ni à l'eau. Ne les mettez pas en court-circuit. Pour les mettre au rebut, conformez-vous à la réglementation en vigueur. Lorsque vous remplacez la pile de sauvegarde ou celle de l'horloge temps réel, veillez à n'utiliser que les modèles cités dans la liste de pièces détachées adéquate. Une batterie ou une pile inappropriée risque de prendre feu ou d'exploser.

Die Bereitschaftsbatterie, die sich unter dem Diskettenlaufwerk befindet, kann geringe Mengen Nickel und Cadmium enthalten. Sie darf nicht zerlegt, wiederaufgeladen, kurzgeschlossen, oder Feuer oder Wasser ausgesetzt werden. Bei der Entsorgung die örtlichen Bestimmungen für Sondermüll beachten. Beim Ersetzen der Bereitschafts- oder Systembatterie nur Batterien des Typs verwenden, der in der Ersatzteilliste aufgeführt ist. Der Einsatz falscher Batterien kann zu Entzündung oder Explosion führen.

סוללות המתנה מסוימות מכילות כמות קטנה של ניקל וקדמיום. אין לפרק סוללות המתנה, לטעון אותה מחדש, להשליך אותה לאש או למים או לקצר אותה. יש לשלוק את הסוללה בנדרש על ידי התקנות והחוקים המקומיים. יש להשתמש רק בסוללה המומייעה ברשימת החלקים המתאימה. שימוש בסוללה לא מתאימה עלול לגרום להצתה או התפוצצות של הסוללה.

Alcune batterie di riserva contengono una piccola quantità di nichel e cadmio. Non smontarle, ricaricarle, gettarle nel fuoco o nell'acqua né cortocircuitarle. Smaltirle secondo la normativa in vigore (DPR 915/82, successive disposizioni e disposizioni locali). Quando si sostituisce la batteria dell'RTC (real time clock) o la batteria di supporto, utilizzare soltanto i tipi inseriti nell'appropriato Catalogo parti. L'impiego di una batteria non adatta potrebbe determinare l'incendio o l'esplosione della batteria stessa.

予備バッテリーの中には少量のニッケルとカドミウムが含まれているものがあります。したがって、予備バッテリーの分解、再充電、火または水の中への投棄、またはショートさせることは決して行わないでください。バッテリーを廃棄する場合は地方自治体の条例に従ってください。適切なパーツ・リストにあるバッテリーだけをを使用してください。誤ったバッテリーを使用すると、バッテリーが発火したり、爆発したりすることがあります。

Algunas baterías de reserva contienen una pequeña cantidad de níquel y cadmio. No las desmonte, ni recargue, ni las eche al fuego o al agua ni las cortocircuite. Deséchelas tal como dispone la normativa local. Utilice sólo baterías que se encuentren en la lista de piezas. La utilización de una batería no apropiada puede provocar la ignición o explosión de la misma.

Safety notice 3**⚠ DANGER**

The battery pack contains small amounts of nickel. Do not disassemble it, throw it into fire or water, or short-circuit it. Dispose of the battery pack as required by local ordinances or regulations. Use only the battery in the appropriate parts listing when replacing the battery pack. Use of an incorrect battery can result in ignition or explosion of the battery.

La batterie contient du nickel. Ne la démontez pas, ne l'exposez ni au feu ni à l'eau. Ne la mettez pas en court-circuit. Pour la mettre au rebut, conformez-vous à la réglementation en vigueur. Lorsque vous remplacez la batterie, veuillez à n'utiliser que les modèles cités dans la liste de pièces détachées adéquate. En effet, une batterie inappropriée risque de prendre feu ou d'exploser.

Akkus enthalten geringe Mengen von Nickel. Sie dürfen nicht zerlegt, wiederaufgeladen, kurzgeschlossen, oder Feuer oder Wasser ausgesetzt werden. Bei der Entsorgung die örtlichen Bestimmungen für Sondermüll beachten. Beim Ersetzen der Batterie nur Batterien des Typs verwenden, der in der Ersatzteilliste aufgeführt ist. Der Einsatz falscher Batterien kann zu Entzündung oder Explosion führen.

מאזו הסוללה מכיל כמות קטנה של ניקל וקדמיום. אין לפרק את מאזו הסוללה, להשליך אותו לאש או למים או לקצר אותו. יש לסלק את מאזו הסוללה הסוללה כנדרש על ידי התקנות החוקיים המקומיים. יש להשתמש רק בסוללה המובנית ברשימת החלקים המותאמת בזמן החלפת מאזו הסוללה. שימוש בסוללה לא מתאימה עלול לגרום להצתה או התפוצצות של הסוללה.

La batteria contiene piccole quantità di nichel. Non smontarla, gettarla nel fuoco o nell'acqua né cortocircuitarla. Smaltirla secondo la normativa in vigore (DPR 915/82, successive disposizioni e disposizioni locali). Quando si sostituisce la batteria, utilizzare soltanto i tipi inseriti nell'appropriato Catalogo parti. L'impiego di una batteria non adatta potrebbe determinare l'incendio o l'esplosione della batteria stessa.

バッテリー・パックには少量のニッケルが含まれています。バッテリー・パックを分解したり、火または水の中に投げ込んだり、ショートさせないでください。バッテリー・パックの廃棄にあたっては、地方自治体の条例または規則に従ってください。バッテリー・パックを交換するときは、適切なパーツ・リストにあるバッテリーだけを使用してください。誤ったバッテリーを使用すると、バッテリーが発火したり、爆発したりすることがあります。

Las baterías contienen pequeñas cantidades de níquel. No las desmonte, ni recargue, ni las eche al fuego o al agua ni las cortocircuite. Deséchelas tal como dispone la normativa local. Utilice sólo baterías que se encuentren en la lista de piezas al sustituir la batería. La utilización de una batería no apropiada puede provocar la ignición o explosión de la misma.

Safety notice 4

DANGER

The lithium battery can cause a fire, an explosion, or a severe burn. Do not recharge it, remove its polarized connector, disassemble it, heat it above 100°C (212°F), incinerate it, or expose its cell contents to water. Dispose of the battery as required by local ordinances or regulations. Use only the battery in the appropriate parts listing. Use of an incorrect battery can result in ignition or explosion of the battery.

La pile de sauvegarde contient du lithium. Elle présente des risques d'incendie, d'explosion ou de brûlures graves. Ne la rechargez pas, ne retirez pas son connecteur polarisé et ne la démontez pas. Ne l'exposez pas à une température supérieure à 100°C, ne la faites pas brûler et n'en exposez pas le contenu à l'eau. Mettez la pile au rebut conformément à la réglementation en vigueur. Une pile inappropriée risque de prendre feu ou d'exploser.

Die Systematterie ist eine Lithiumatterie. Sie kann sich entzünden, explodieren oder schwere Verbrennungen hervorrufen. Batterien dieses Typs dürfen nicht aufgeladen, zerlegt, über 100 C erhitzt oder verbrannt werden. Auch darf ihr Inhalt nicht mit Wasser in Verbindung gebracht oder der zur richtigen Polung angebrachte Verbindungsstecker entfernt werden. Bei der Entsorgung die örtlichen Bestimmungen für Sondermüll beachten. Beim Ersetzen der Batterie nur Batterien des Typs verwenden, der in der Ersatzteilliste aufgeführt ist. Der Einsatz falscher Batterien kann zu Entzündung oder Explosion führen.

סוללת הליתיום עלולה לגרום לשריפה, להתפוצצות או לפגיעת עקשות. אין לטעון אותה מחדש, לשלוק את המחבר המקוטב שלה, למרק אותה או לחמם אותה לטמפרטורה העולה על 100 מעלות צלזיוס. אין לשרוף את הסוללה ואין לחשוף את תוכן התא למים. יש לשלוק את הסוללה כנדרש במקנות ובחוקים המקומיים. יש להשתמש רק בסוללה המומייעה ברשימת החלקים המתאימים. שימוש בסוללה אחרת עלול לגרום לשכנת שריפה או התפוצצות.

La batteria di supporto e una batteria al litio e puo incendiarsi, esplodere o procurare gravi ustioni. Evitare di ricaricarla, smontarne il connettore polarizzato, smontarla, riscaldarla ad una temperatura superiore ai 100 gradi centigradi, incendiarla o gettarla in acqua. Smaltirla secondo la normativa in vigore (DPR 915/82, successive disposizioni e disposizioni locali). L'impiego di una batteria non adatta potrebbe determinare l'incendio o l'esplosione della batteria stessa.

リチウム・バッテリーは、火災、爆発、または重症のやけどを引き起こすことがあります。バックアップ・バッテリーの充電、その極性コネクタの取り外し、バッテリー本体の分解、100°C (212°F) 以上への加熱、焼却、電池の中身を水に浸すことはしないでください。バッテリーを廃棄する場合は地方自治体の条例に従ってください。適切なパーツ・リストにあるバッテリーだけを使用してください。誤ったバッテリーを使用すると、バッテリーが発火したり、爆発したりすることがあります。

La batería de repuesto es una batería de litio y puede provocar incendios, explosiones o quemaduras graves. No la recargue, ni quite el conector polarizado, ni la desmonte, ni caliente por encima de los 100°C (212°F), ni la incinerar ni exponga el contenido de sus celdas al agua. Deséchela tal como dispone la normativa local.

Safety notice 5

If the LCD breaks and the fluid from inside the LCD gets into your eyes or on your hands, immediately wash the affected areas with water at least for 15 minutes. Seek medical care if any symptoms caused by the fluid are present after washing.

Si le panneau d'affichage à cristaux liquides se brise et que vous recevez dans les yeux ou sur les mains une partie du fluide, rincez-les abondamment pendant au moins quinze minutes. Consultez un médecin si des symptômes persistent après le lavage.

Die Leuchtstoffröhre im LCD-Bildschirm enthält Quecksilber. Bei der Entsorgung die örtlichen Bestimmungen für Sondermüll beachten. Der LCD-Bildschirm besteht aus Glas und kann zerbrechen, wenn er unsachgemäß behandelt wird oder der Computer auf den Boden fällt. Wenn der Bildschirm beschädigt ist und die darin befindliche Flüssigkeit in Kontakt mit Haut und Augen gerät, sollten die betroffenen Stellen mindestens 15 Minuten mit Wasser abgespült und bei Beschwerden anschließend ein Arzt aufgesucht werden.

אם מסך הנביש הנוזלי (LCD) נשבר והנוזל מתוך המסך בא במגע עם עיניכם או ידיכם, שטפו את האזורים הנוגעים מיד במים במשך 15 דקות לפחות. פנו לקבלת עזרה רפואית אם תסמינים הנובעים מהמגע עם הנוזל נמשכים לאחר השטיפה.

Nel caso che caso l'LCD si dovesse rompere ed il liquido in esso contenuto entrasse in contatto con gli occhi o le mani, lavare immediatamente le parti interessate con acqua corrente per almeno 15 minuti; poi consultare un medico se i sintomi dovessero permanere.

LCD が破損し、LCD の中の液体が目に入ったり、手に触れたりした場合は、液体が触れた部分を少なくとも 15 分間洗い流してください。洗い流した後に、液体によって何らかの症状が現れた場合は、医師の治療を受けてください。

Si la LCD se rompe y el fluido de su interior entra en contacto con sus ojos o sus manos, lave inmediatamente las áreas afectadas con agua durante 15 minutos como mínimo. Obtenga atención medica si se presenta algún sintoma del fluido despues de lavarse.

Safety notice 6

DANGER

To avoid shock, do not remove the plastic cover that protects the lower part of the inverter card.

Afin d'éviter tout risque de choc électrique, ne retirez pas le cache en plastique protégeant la partie inférieure de la carte d'alimentation.

Aus Sicherheitsgründen die Kunststoffabdeckung, die den unteren Teil der Spannungswandlerplatine umgibt, nicht entfernen.

כדי למנוע התחשמלות, אין להסיר את מכסה הפלסטיק המגן על חלקו התחתון של הכרטיס ההפוך.

Per evitare scosse elettriche, non rimuovere la copertura in plastica che avvolge la parte inferiore della scheda invertitore.

感電を防ぐため、インバーター・カードの下部を保護しているプラスチック・カバーを外さないでください。

Para evitar descargas, no quite la cubierta de plástico que rodea la parte baja de la tarjeta invertida.

Safety notice 7

DANGER

Though the main batteries have low voltage, a shorted or grounded battery can produce enough current to burn personnel or combustible materials.

Bien que le voltage des batteries principales soit peu élevé, le court-circuit ou la mise à la masse d'une batterie peut produire suffisamment de courant pour brûler des matériaux combustibles ou causer des brûlures corporelles graves.

Obwohl Hauptbatterien eine niedrige Spannung haben, können sie doch bei Kurzschluß oder Erdung genug Strom abgeben, um brennbare Materialien zu entzünden oder Verletzungen bei Personen hervorzurufen.

אף שהסוללות הראשיות הן בעלות מתח נמוך, סוללה מקוצרת או מוארקות עלולה להפיק זרם מספיק לגרימת כוויות או להצתת חומרים דליקים.

Sebbene le batterie di alimentazione siano a basso voltaggio, una batteria in corto circuito o a massa può fornire corrente sufficiente da bruciare materiali combustibili o provocare ustioni ai tecnici di manutenzione.

メイン・バッテリーの電圧は低くても、ショートしたり、接地したバッテリーが、作業者にやけどを負わせたり、可燃物を燃やすだけの電流を発生させる場合があります。

Aunque las baterías principales tienen un voltaje bajo, una batería cortocircuitada o con contacto a tierra puede producir la corriente suficiente como para quemar material combustible o provocar quemaduras en el personal.

Safety notice 8** DANGER**

Before removing any FRU, turn off the computer, unplug all power cords from electrical outlets, remove the battery pack, and then disconnect any interconnecting cables.

Avant de retirer une unité remplaçable en clientèle, mettez le système hors tension, débranchez tous les cordons d'alimentation des socles de prise de courant, retirez la batterie et déconnectez tous les cordons d'interface.

Die Stromzufuhr muß abgeschaltet, alle Stromkabel aus der Steckdose gezogen, der Akku entfernt und alle Verbindungskabel abgenommen sein, bevor eine FRU entfernt wird.

לפני סילוק FRU כלשהו, יש לכבות את המחשב, לנתק את כל כבלי החשמל משקעי החשמל, להוציא את מארזי הסוללה, וזו לנתק כבלי חיבור אחרים אם יש כאלה.

Prima di rimuovere qualsiasi FRU, spegnere il sistema, scollegare dalle prese elettriche tutti i cavi di alimentazione, rimuovere la batteria e poi scollegare i cavi di interconnessione.

FRU を取り外す前に、**ThinkPad** の電源を切って、すべての電源コードをコンセントから外してください。次に、バッテリー・パックを外し、相互接続ケーブルを外してください。

Antes de quitar una FRU, apague el sistema, desenchufe todos los cables de las tomas de corriente eléctrica, quite la batería y, a continuación, desconecte cualquier cable de conexión entre dispositivos.

Laser compliance statement

Some models of Lenovo computer are equipped from the factory with an optical storage device such as a CD-ROM drive or a DVD-ROM drive. Such devices are also sold separately as options. If one of these drives is installed, it is certified in the U.S. to conform to the requirements of the Department of Health and Human Services 21 Code of Federal Regulations (DHHS 21 CFR) Subchapter J for Class 1 laser products. Elsewhere, the drive is certified to conform to the requirements of the International Electrotechnical Commission (IEC) 825 and CENELEC EN 60 825 for Class 1 laser products.

If a CD-ROM drive, a DVD-ROM drive, or another laser device is installed, note the following:

CAUTION

Use of controls or adjustments or performance of procedures other than those specified herein might result in hazardous radiation exposure.

O uso de controles, ajustes ou desempenho de procedimentos diferentes daqueles aqui especificados pode resultar em perigosa exposição à radiação.

凡未在这里指明的任何控制用法、调整、行为，都会导致严重后果。

Pour éviter tout risque d'exposition au rayon laser, respectez les consignes de réglage et d'utilisation des commandes, ainsi que les procédures décrites.

Werden Steuer- und Einstellelemente anders als hier festgesetzt verwendet, kann gefährliche Laserstrahlung auftreten.

Az itt előírt eljárásoktól, beállításoktól és vezérlésektől eltérni a lézersugárzás veszélye miatt kockázatos!

L'utilizzo di controlli, regolazioni o l'esecuzione di procedure diverse da quelle specificate possono provocare l'esposizione a.

Использование элементов настройки и выполнение процедур иных, чем указано здесь, может привести к опасному радиационному облучению.

Použitie kontrol, úprav alebo iných vykonaní od iných výrobcov, ako je v tomto špecifikované, mohlo by mať za následok nebezpečenstvo vystavenia sa vyžiarovaniu.

本書で指定された内容以外の、お客様による整備、調整、または手順を行った場合、レーザー光の放射の危険があります。

El uso de controles o ajustes o la ejecución de procedimientos distintos de los aquí especificados puede provocar la exposición a radiaciones peligrosas.

Opening the CD-ROM drive, the DVD-ROM drive, or any other optical storage device could result in exposure to hazardous laser radiation. There are no serviceable parts inside those drives. **Do not open.**

A CD-ROM drive, a DVD-ROM drive, or any other storage device installed may contain an embedded Class 3A or Class 3B laser diode. Note the following:

⚠ DANGER

Emits visible and invisible laser radiation when open. Do not stare into the beam, do not view directly with optical instruments, and avoid direct exposure to the beam.

Radiação por raio laser ao abrir. Não olhe fixo no feixe de luz, não olhe diretamente por meio de instrumentos óticos e evite exposição direta com o feixe de luz.

开启时会有激光发射时，请勿直视激光束，请勿直接查看视觉仪器，并且避免直接接触在激光光束之中。

Rayonnement laser si carter ouvert. Évitez de fixer le faisceau, de le regarder directement avec des instruments optiques, ou de vous exposer au rayon.

Laserstrahlung bei geöffnetem Gerät. Nicht direkt oder über optische Instrumente in den Laserstrahl sehen und den Strahlungsbereich meiden.

Kinyitáskor lézersugár ! Ne nézzen bele se szabad szemmel, se optikai eszközökkel. Kerülje a sugárnyalábbal való érintkezést!

Apriendo l'unità vengono emesse radiazioni laser. Non fissare il fascio, non guardarlo direttamente con strumenti ottici e evitare l'esposizione diretta al fascio.

Открывая, берегитесь лазерного излучения. Не смотрите на луч, не разглядывайте его с помощью оптических инструментов, а также избегайте прямого воздействия лазерного луча.

Keď je laserová jednotka otvorená. Vyhnite sa priamemu pohľadu a nehladte priamo s optickými nástrojmi do lúča a vyhnite sa priamemu vystaveniu lúčov.

開けるとレーザー光が放射されます。光線を見つめたり、光学機械を使って直接見たりしないでください。

Radiación láser al abrir. No mire fijamente ni examine con instrumental óptico el haz de luz. Evite la exposición directa al haz.

Important service information

This chapter presents the following important service information:

- “Strategy for replacing FRUs” on page 16
 - “Strategy for replacing a hard disk drive” on page 17
 - “Important notice for replacing a system board” on page 17
- “Important information about replacing RoHS compliant FRUs” on page 18

Important:

BIOS and device driver fixes are customer-installable. The BIOS and device drivers are posted on the customer support site:

<http://support.lenovo.com>.

Strategy for replacing FRUs

Before replacing parts:

Make sure that all software fixes, drivers, and BIOS downloads are installed before replacing any FRUs listed in this manual.

After a system board is replaced, ensure that the latest BIOS is loaded to the system board before completing the service action.

To download software fixes, drivers, and BIOS, follow the steps below:

1. Go to <http://support.lenovo.com>.
2. Enter the serial number or select a product or use Lenovo smart downloading.
3. Select the BIOS/Driver/Applications and download.
4. Follow the directions on the screen and install the necessary software.

Use the following strategy to prevent unnecessary expense for replacing and servicing FRUs:

- If you are instructed to replace an FRU, but the replacement does not solve the problem, reinstall the original FRU before you continue.
- Some computers have both a processor board and a system board. If you are instructed to replace either of them, and replacing one of them does not solve the problem, reinstall that board, and then replace the other one.
- If an adapter or a device consists of more than one FRU, any of the FRUs may be the cause of the error. Before replacing the adapter or device, remove the FRUs one by one to see if the symptoms change. Replace only the FRU that changed the symptoms.

Attention: The setup configuration on the computer you are servicing may have been customized. Running Automatic Configuration may alter the settings. Note the current configuration settings (using the View Configuration option); then, when service has been completed, verify that those settings remain in effect.

Strategy for replacing a hard disk drive

Always try to run a low-level format before replacing a hard disk drive. This will cause all customer data on the hard disk to be lost. Make sure that the customer has a current backup of the data before performing this action.

Attention: The drive startup sequence in the computer you are servicing may have been changed. Be extremely careful during write operations such as copying, saving, or formatting. If you select an incorrect drive, data or programs can be overwritten.

Important notice for replacing a system board

Some components mounted on a system board are very sensitive. Improper handling can cause damage to those components, and may cause a system malfunction.

Attention: When handling a system board:

- Do not drop the system board or apply any excessive force to it.
- Avoid rough handling of any kind.
- Avoid bending the system board and hard pushing to prevent cracking at each BGA (Ball Grid Array) chipset.

Important information about replacing RoHS compliant FRUs

RoHS, The Restriction of Hazardous Substances in Electrical and Electronic Equipment Directive (2002/95/EC) is a European Union legal requirement affecting the global electronics industry. RoHS requirements must be implemented on Lenovo products placed on the market after June 2006. Products on the market before June 2006 are not required to have RoHS compliant parts. If the original FRU parts are non-compliant, replacement parts can also be non-compliant. In all cases if the original FRU parts are RoHS compliant, the replacement part must also be RoHS compliant.

Note: RoHS and non-RoHS FRU part numbers with the same fit and function are identified with unique FRU part numbers.

Lenovo plans to transit to RoHS compliance well before the implementation date and expects its suppliers to be ready to support Lenovo's requirements and schedule in the EU. Products sold in 2005 and 2006 will contain some RoHS compliant FRUs. The following statement pertains to these products and any product Lenovo produces containing RoHS compliant FRUs.

RoHS compliant FRUs have unique FRU part numbers. Before or after the RoHS implementation date, failed RoHS compliant parts must always be replaced with RoHS compliant ones, so only the FRUs identified as compliant in the system HMM or direct substitutions for those FRUs may be used.

Products marketed before June 2006		Products marketed after June 2006	
Current or original part	Replacement FRU	Current or original part	Replacement FRU
Non-RoHS	Can be Non-RoHS	Must be RoHS	Must be RoHS
Non-RoHS	Can be RoHS		
Non-RoHS	Can sub to RoHS		
RoHS	Must be RoHS		

Note: A direct substitution is a part with a different FRU part number that is automatically shipped by the distribution center at the time of the order.

General checkout

This chapter presents the following information:

- “What to do first” on page 20
- “Power system checkout” on page 21

Before you go to the checkout, make sure to read the following important notes:

Important notes:

- **Only certified trained personnel can service the computer.**
- **Before replacing any FRU, read the entire page on removing and replacing FRUs.**
- **Carefully remove screws for reuse when replacing FRUs.**
- **Be extremely careful during such write operations as copying, saving, or formatting.** Drives in the computer that you are servicing sequence might have been altered. If you select an incorrect drive, data or programs might be overwritten.
- **Replace an FRU only with another FRU of the correct model.** When you replace an FRU, make sure that the machine model and the FRU part number are correct by referring to the FRU parts list.
- **An FRU should not be replaced just because of a single, unreproducible failure.** Single failures can occur for a variety of reasons that have nothing to do with a hardware defect, such as cosmic radiation, electrostatic discharge, or software errors. Consider replacing an FRU only when a problem recurs. If you suspect that an FRU is defective, clear the error logs and run the test again. If the error does not recur, do not replace the FRU.
- **Be careful not to replace a nondefective FRU.**

What to do first

When you do return an FRU, you must include the following information in the parts exchange form or parts return form that you attach to it:

1. Name and phone number of servicer
2. Date of service
3. Date on which the machine failed
4. Date of purchase
5. Procedure index and page number in which the failing FRU was detected
6. Failing FRU name and part number
7. Machine type, model number, and serial number
8. Customer's name and address

Note for warranty: During the warranty period, the customer may be responsible for repair costs if the computer damage was caused by misuse, accident, modification, unsuitable physical or operating environment, or improper maintenance by the customer.

The following is a list of some common items that are not covered under warranty and some symptoms that might indicate that the system was subjected to stress beyond normal use.

Before checking problems with the computer, determine whether the damage is covered under the warranty by referring to the following list:

The following are not covered under warranty:

- LCD panel cracked from the application of excessive force or from being dropped
- Scratched (cosmetic) parts
- Distortion, deformation, or discoloration of the cosmetic parts
- Plastic parts, latches, pins, or connectors that have been cracked or broken by excessive force
- Damage caused by liquid spilled into the system
- Damage caused by the improper insertion of a PC Card or the installation of an incompatible card
- Improper disk insertion or use of an optical drive
- Diskette drive damage caused by pressure on the diskette drive cover, foreign material in the drive, or the insertion of a diskette with multiple labels
- Damaged or bent diskette eject button
- Fuses blown by attachment of a nonsupported device
- Forgotten computer password (making the computer unusable)
- Sticky keys caused by spilling a liquid onto the keyboard
- Use of an incorrect AC adapter on laptop products

The following symptoms might indicate damage caused by nonwarranted activities:

- Missing parts might be a symptom of unauthorized service or modification.
- If the spindle of a hard disk drive becomes noisy, it may have been subjected to excessive force, or dropped.

Power system checkout

To verify a symptom, follow the steps below:

1. Turn off the computer.
2. Remove the battery pack.
3. Connect the AC adapter.
4. Make sure that power is supplied when you turn on the computer.
5. Turn off the computer.
6. Disconnect the AC adapter and install the charged battery pack.
7. Make sure that the battery pack supplies power when you turn on the computer.

If you suspect a power problem, see the appropriate one of the following power supply checkouts:

- “Checking the AC adapter” on page 21
- “Checking operational charging” on page 21
- “Checking the battery pack” on page 22

Checking the AC adapter

You are here because the computer fails only when the AC adapter is used.

- If the power-on indicator does not turn on, check the power cord of the AC adapter for correct continuity and installation.
- If the computer does not charge during operation, go to “Checking operational charging”.

To check the AC adapter, follow the steps below:

1. Unplug the AC adapter cable from the computer.
2. Measure the output voltage at the plug of the AC adapter cable. See the following figure:

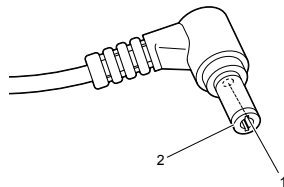

Pin	Voltage (V DC)
1	+20
2	0

Note: Output voltage for the AC adapter pin No. 2 may differ from the one you are servicing.

3. If the voltage is not correct, replace the AC adapter.
4. If the voltage is acceptable, do the following:
 - Replace the system board.
 - If the problem persists, go to “Lenovo ideapad 320-15ISK/ideapad 320H-15ISK/ideapad 320L-15ISK/ideapad 320R-15ISK/ideapad 320E-15ISK/ideapad 320-15IKB/ideapad 320H-15IKB/ideapad 320L-15IKB/ideapad 320R-15IKB/ideapad 320E-15IKB/ideapad 320-15IKB Touch” on page 27.

Note: Noise from the AC adapter does not always indicate a defect.

Checking operational charging

To check whether the battery charges properly during operation, use a discharged battery pack or a battery pack that has less than 50% of the total power remaining when installed in the computer.

Perform operational charging. If the battery status indicator or icon does not light on, remove the battery pack and let it return to room temperature. Reinstall the battery pack. If the charge indicator or icon is still off, replace the battery pack.

If the charge indicator still does not light on, replace the system board. Then reinstall the battery pack. If it is still not charged, go to the next section.

Checking the battery pack

Battery charging does not start until the Power Meter shows that less than 95% of the total power remains; under this condition the battery pack can charge to 100% of its capacity. This protects the battery pack from being overcharged or from having a shortened life.

To check your battery, move your cursor to the Power Meter icon in the icon tray of the Windows[®] taskbar and wait for a moment (but do not click it), and the percentage of battery power remaining is displayed. To get detailed information about the battery, double-click the Power Meter icon.

Note: If the battery pack becomes hot, it may not be able to be charged. Remove it from the computer and leave it at room temperature for a while. After it cools down, reinstall and recharge it.

Related service information

This chapter presents the following information:

- “Restoring the factory contents by using OneKey Recovery” on page 23
- “Passwords” on page 24
- “Power management” on page 25

Restoring the factory contents by using OneKey Recovery

Restore of factory default

The Lenovo ideapad 320-15ISK/ideapad 320H-15ISK/ideapad 320L-15ISK/ideapad 320R-15ISK/ideapad 320E-15ISK/ideapad 320-15IKB/ideapad 320H-15IKB/ideapad 320L-15IKB/ideapad 320R-15IKB/ideapad 320E-15IKB/ideapad 320-15IKB Touch computers come with pre-installed OneKey Recovery System. In order to save application files and the initial backed up files of the system, the hard disk in a Lenovo computer includes a hidden partition when it is shipped. If you need to restore the system to the point of your first boot up, just enter Lenovo OneKey Recovery System and run **System Recovery**. For details of OneKey Recovery System, see *the User Guide for Lenovo OneKey Recovery system*.

Note: This will delete all the new data on the system partition (C drive), which is not recoverable. Make sure to back up your critical data before you perform this action.

When you use the recovery discs to boot your computer, the system will enter the user interface for system recovery automatically. Please follow the prompt to insert the backup discs to complete the whole recovery process.

Note: The recovery process might take up to 2 hours.

Passwords

As many as three passwords may be needed for any Lenovo computer: the power-on password (POP), the hard disk password (HDP), and the administrator password.

If any of these passwords has been set, a prompt for it appears on the screen whenever the computer is turned on. The computer does not start until the password is entered.

Power-on password

A power-on password (POP) protects the system from being powered on by an unauthorized person. The password must be entered before an operating system can be booted.

Hard-disk password

There are two hard-disk passwords (HDPs):

+ User HDP - for the user

+ Master HDP - for the system administrator, who can use it to get access to the hard disk drive even if the user has changed the user HDP

Attention: If the user HDP has been forgotten, check whether a master HDP has been set. If it has, it can be used for access to the hard disk drive. If no master HDP is available, neither Lenovo nor Lenovo authorized service technicians provide any services to reset either the user or the master HDP, or to recover data from the hard disk drive. The hard disk drive can be replaced for a scheduled fee.

Administrator password

Administrator password controls the access of the whole setup utility. Only after the Administrator password has been set can the User password be set. If Administrator password was cleared, the User password was cleared too.

Power management

Note: Power management modes are not supported for APM operating system.

To reduce power consumption, the computer has three power management modes: screen blank, sleep (standby), and hibernation.

Screen blank state

If the time set on the “Turn off monitor” timer in the operating system expires, the LCD backlight turns off. You can also turn off the LCD backlight by pressing .

To end screen blank state and resume normal operation, press any key on the keyboard.

Putting the computer to sleep or shutting it down

When you have finished working with your computer, you can put it to sleep or shut it down.

Putting your computer to sleep

If you will be away from your computer for only a short time, put the computer to sleep.

When the computer is in sleep mode, you can quickly wake it to resume use, bypassing the startup process.

To put the computer to sleep, do one of the following:

- Close the display lid.
- Press and hold the Power key for about 1 to 5 seconds.
- Move the cursor to the lower-left corner, and then select the Start button. Select **Power**  → **Sleep**.

Note: Put your computer to sleep before you move it. Moving your computer while the hard disk drive is spinning can damage the hard disk, causing loss of data.

To wake up the computer, perform the following:

- Press any key on the keyboard.

Shutting down the computer

If you are not going to use your computer for a long time, shut it down.
To shut down your computer, do one of the following:

- Select the Start button, then select **Power**  → **Shut down**.



- Right-click or press the Start button in the lower-left corner and select **Shut down or sign out** → **Shut down**.

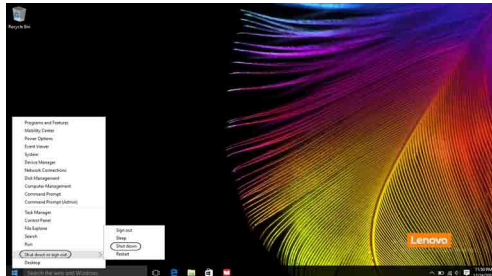

Lenovo ideapad 320-15ISK/ideapad 320H-15ISK/ideapad 320L-15ISK/ideapad 320R-15ISK/ideapad 320E-15ISK/ ideapad 320-15IKB/ideapad 320H-15IKB/ideapad 320L-15IKB/ideapad 320R-15IKB/ideapad 320E-15IKB/ ideapad 320-15IKB Touch

This chapter presents the following product-specific service references and product-specific parts information:

- “Specifications” on page 27
- “Status indicators” on page 29
- “Hotkeys” on page 30
- “FRU replacement notices” on page 31
- “Removing and replacing an FRU” on page 32
- “Locations” on page 62
- “Parts list” on page 64

Specifications

The following table lists the specifications of the Lenovo ideapad 320-15ISK/ideapad 320H-15ISK/ideapad 320L-15ISK/ideapad 320R-15ISK/ideapad 320E-15ISK/ideapad 320-15IKB/ideapad 320H-15IKB/ideapad 320L-15IKB/ideapad 320R-15IKB/ideapad 320E-15IKB/ideapad 320-15IKB Touch:

Table 1. Specifications

Form Factor	
Dimensions	Appr. 378 mm × 260 mm × 22.9 mm
Weight	Appr. 2.2 kg with battery
LCD size	15.6-inch
Processor	
See the system properties of your computer, you can do this as follows: Click Control Panel , then click Hardware and Sound , click Device Manager under Devices and Printers and double click Processors .	
Memory	
Type and speed	DDR4-2133 MHz
Maximum supported capacity	16 GB
SSD	
Interface	SATA 3
Hard disk drive	
Form factor	2.5-inch, 7 mm
Capacity	SSD + HDD (on select models)
Interface	SATA 2/SATA 3

Table 1. Specifications (continued)

Optical Drive	
Form factor	9.0 mm
Type	Writer
Display	
Display resolution (LCD)	1366 × 768 pixels HD/1920 × 1080 pixels FHD
LCD backlight	LED
I/O Ports	
USB	USB 3.0 × 2, Type-C (Support USB 3.1 Gen 1, Output 5V DC, 0.9A DC) × 1
Audio	Combo audio jack × 1
Video/Audio	HDMI slot × 1
Ethernet	RJ-45 × 1
Memory card slot	4 in 1 slot × 1 (SD/SDHC/SDXC/MMC)
Battery pack	
Type	Polymer
Cells/Capacity	2 Cell, 30 Wh/35 Wh
Note: The capacity given here is the typical or average capacity as measured in a specific test environment. Capacities measured in other environments may differ but are no lower than the rated capacity (see product label).	
AC power adapter	
Input	100-240 V, 50-60 Hz
Output voltage	20 V DC
Power	45/65 W
Miscellaneous	
Camera	0.3 M/HD
Security	Kensington slot × 1

Status indicators

The system status indicators below show the computer status:

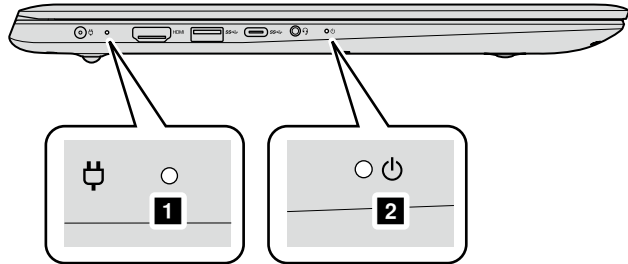

Table 2. Status indicators













AC power adapter status	Indicator status	Meaning
Disconnected	Off	The computer is in sleep mode or turned off; The battery has more than 20% charge.
	Solid amber	The battery has between 5% and 20% charge.
	Fast blinking amber	The battery has between 1% and 5% charge.
Connected	Slow blinking amber	The battery is being charged. When battery charge reaches 20%, the blinking color changes to white.
	Slow blinking white	The battery has between 20% and 80% charge and is still charging. When the battery reaches 80% charge the light will stop blinking.
	Solid white	The battery has more than 80% charge, charging will continue until the battery is fully charged.

Indicator	Indicator status	Meaning
Power status indicator	On (solid white)	The computer is powered on.
	Blinking	The computer is in sleep mode.
	Off	The computer is powered off.

Hotkeys

You can access certain system settings quickly by pressing the appropriate hotkeys.

Table 3. Hotkeys

	: Mutes/unmutes the sound.		: Enables/disables airplane mode.
	: Decreases the volume level.		: Enables/disables camera.
	: Increases the volume level.		: Locks/unlocks the LCD screen.
	: Enables/disables microphone.		: Enables the external projector or dangles the external display.
	: Refreshes page.		: Decreases display brightness.
	: Enables/disables the touch pad.		: Increases display brightness.

FRU replacement notices

This section presents notices related to removing and replacing parts. Read this section carefully before replacing any FRU.

Screw notices

Loose screws can cause a reliability problem. In the Lenovo computer, this problem is addressed with special nylon-coated screws that have the following characteristics:

- They maintain tight connections.
- They do not easily come loose, even with shock or vibration.
- They are harder to tighten.
- Each one should be used only once.

Do the following when you service this machine:

- Keep the screw kit in your tool bag.
- Carefully remove screws for reuse when replacing FRUs.
- Use a torque screwdriver if you have one.

Tighten screws as follows:

- **Plastic to plastic**

Turn an additional 90° after the screw head touches the surface of the plastic part:

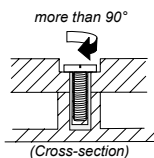

- **Logic card to plastic**

Turn an additional 180° after the screw head touches the surface of the logic card:

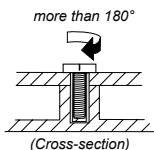

- **Torque driver**

If you have a torque screwdriver, refer to the “Torque” column for each step.

- Make sure that you use the correct screws. If you have a torque screwdriver, tighten all screws firmly to the torque shown in the table. **Carefully remove screws for reuse when replacing FRUs. Make sure that all screws are tightened firmly.**
- Ensure torque screwdrivers are calibrated correctly following country specifications.

Removing and replacing an FRU

This section presents exploded figures with the instructions to indicate how to remove and replace the FRU. Make sure to observe the following general rules:

1. Do not attempt to service any computer unless you have been trained and certified. An untrained person runs the risk of damaging parts.
2. Before replacing any FRU, review “FRU replacement notices” on page 31.
3. Begin by removing any FRUs that have to be removed before the failing FRU. Any of such FRUs are listed at the top of the page. Remove them in the order in which they are listed.
4. Follow the correct sequence in the steps to remove the FRU, as given in the figures by the numbers in square callouts.
5. When turning a screw to replace an FRU, turn it in the direction as given by the arrow in the figure.
6. When removing the FRU, move it in the direction as given by the arrow in the figure.
7. To put the new FRU in place, reverse the removal procedures and follow any of the notes that pertain to replacement. For information about connecting and arranging internal cables, see “Locations” on page 62.
8. When replacing an FRU, use the correct screw as shown in the procedures.

DANGER

Before removing any FRU, turn off the computer, unplug all power cords from electrical outlets, remove the battery pack, and then disconnect any of the interconnecting cables.

Attention: After replacing an FRU, do not turn on the computer until you have made sure that all screws, springs, and other small parts are in place and none are loose inside the computer. Verify this by shaking the computer gently and listening for rattling sounds. Metallic parts or metal flakes can cause electrical short circuits.

Attention: The system board is sensitive to, and can be damaged by, electrostatic discharge. Before touching it, establish personal grounding by touching a ground point with one hand or using an electrostatic discharge (ESD) strap (P/N 6405959) to remove potential shock reasons.

1010 Optical drive

Figure 1. Removal steps of optical drive

Remove the screw **1**. Then pull the optical drive out in the direction shown by arrow **2**.

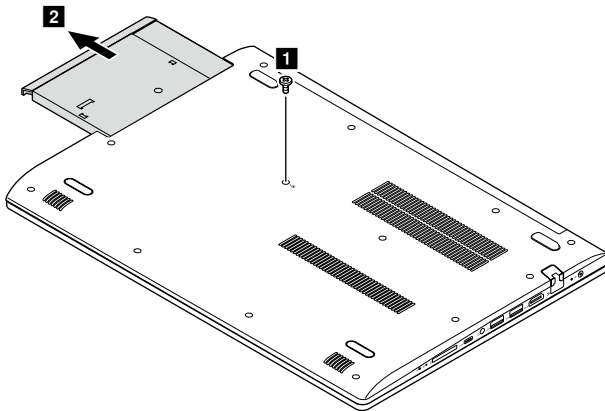

Step	Screw (quantity)	Color	Torque
1	M2.5 × 7 mm, Phillips head, nylok-coated (1) LOW TO UPPER	Black/ Silver	3.0+/-0.3 kgf/cm

Remove the screw **3**, then carefully remove the optical drive bracket and bezel in the directions shown by arrows **4** and **5**.

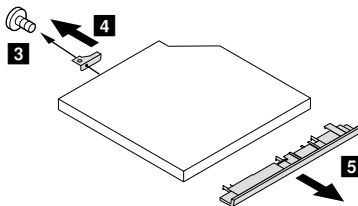

Step	Screw (quantity)	Color	Torque
3	M2 × 3 mm, Phillips head, nylok-coated (1) ODD BRK TO ODD MODULE	Black	1.85+/-0.15 kgf/cm

1020 Base cover

For access, remove this FRU:

- “1010 Optical drive” on page 33

Figure 2. Removal steps of base cover

Remove the screws ■.

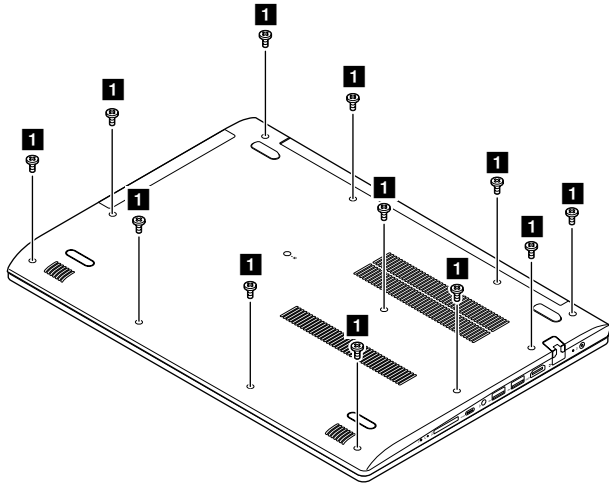

Step	Screw (quantity)	Color	Torque
■	M2.5 × 7 mm, Phillips-head, nylok-coated (12) log low---log up & log low---io board---log up & log low---mb---log up & log low---right side hinge---log up & log low---left side hinge---klock bracket---log up	Black/ Silver	3.0+/-0.3 kgf/cm

Lenovo ideapad 320-15ISK/ideapad 320H-15ISK/ideapad 320L-15ISK/ideapad 320R-15ISK/ideapad 320E-15ISK/ideapad 320-15IKB/ideapad 320H-15IKB/ideapad 320L-15IKB/ideapad 320R-15IKB/ideapad 320E-15IKB/ideapad 320-15IKB Touch

Figure 2. Removal steps of base cover (continued)

Remove the base cover in the directions shown by arrows **2** and **3**.

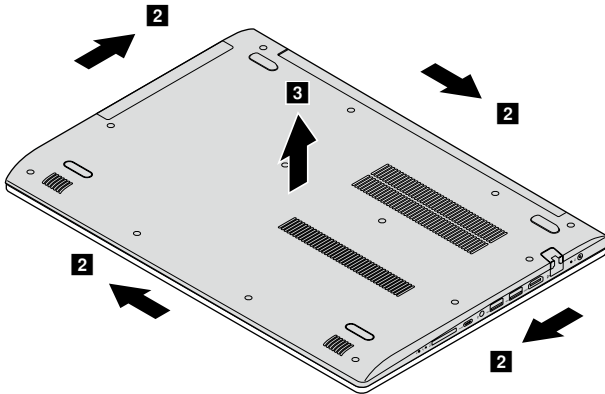

Note: Applying labels to the base cover

The new base cover FRU is shipped with a kit containing labels of several kinds. When you replace the base cover, you need to apply the following labels:

The following labels need to be peeled off from the old base cover and put on the new base cover.

- a** Rating label
- b** Rating label for print
- c** OS label
- d** Office label
- e** Adapter label 65 × 20mm
- f** Argentina label 68 × 6mm
- g** KCC label 50 × 16mm
- h** Indonesia label 32 × 10mm
- i** TW label 70 × 10mm
- l** BIS label 22 × 30mm
- k** WL/BT label 35 × 15mm

For some models, you also need to apply one or two FCC labels. Check the old base cover; if it has one or two FCC labels, find duplicates of them in the label kit and apply them to the new base cover.

For the location of each label, refer to the following figures:

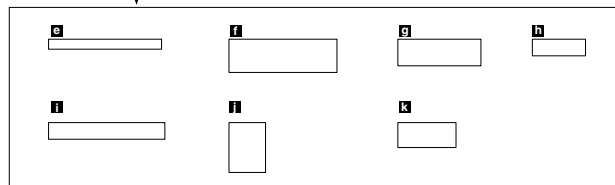
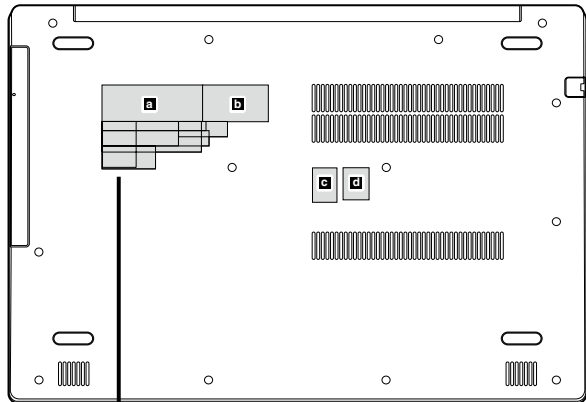

1030 Battery pack

⚠ DANGER

Only use the battery specified in the parts list for your computer. Any other battery could ignite or explode.

For access, remove these FRUs in order:

- “1010 Optical drive” on page 33
- “1020 Base cover” on page 34

Figure 3. Removal steps of battery pack

Detach the battery pack connector in the direction shown by arrow **1**, remove the screws **2**.

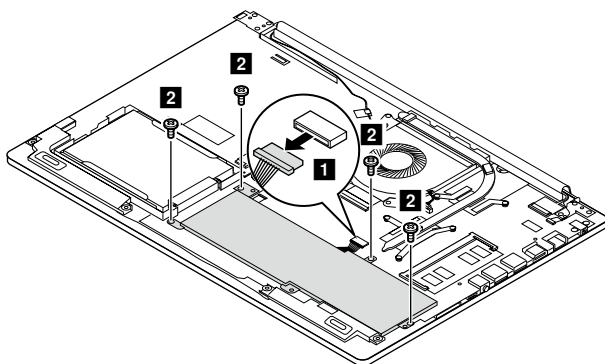

Step	Screw (quantity)	Color	Torque
3	M2 × 6 mm, Phillips-head, nylok-coated (4) battery---log up	Black	1.85+/-0.15 kgf/cm

Figure 3. Removal steps of battery pack (continued)

Remove the battery pack in the direction shown by arrow **3**.

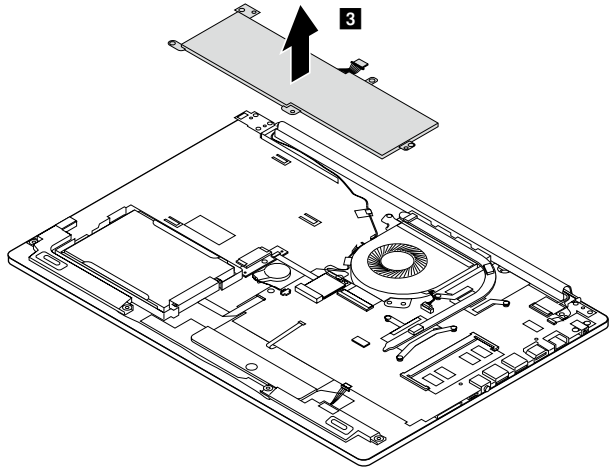

1040 PCI Express Mini Card for wireless LAN

For access, remove these FRUs in order:

- “1010 Optical drive” on page 33
- “1020 Base cover” on page 34
- “1030 Battery pack” on page 37

Important:

The preinstalled WLAN module may only be replaced with a Lenovo approved module in order to comply with FCC and IC regulations. Refer to Table 4 “Parts list—Overall” on page 65 for Lenovo part numbers for the approved modules.

Figure 4. Removal steps of PCI Express Mini Card for wireless LAN

Disconnect the two wireless LAN cables (black, gray) ■, and then remove the screw ■.

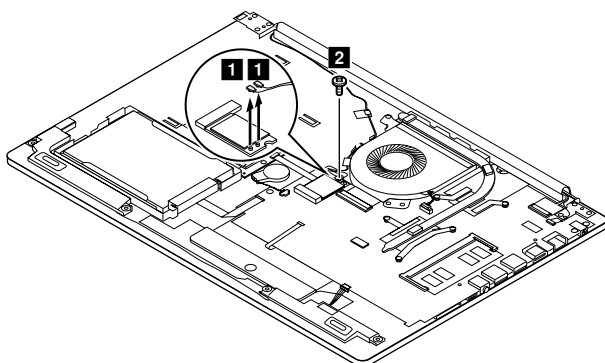

In step ■, unplug the jacks by using the removal tool antenna RF connector (P/N: 08K7159), or pick up the connectors with your fingers and gently unplug them in the direction shown by the arrows.

Notes: The wireless LAN card has 2 cables in step ■.

The wireless LAN card in some models might have 3 cables in step ■.

Step	Screw (quantity)	Color	Torque
■	M2 × 3 mm, Phillips-head, nylok-coated (1) wireless card—log up	Black	1.85+/-0.15 kgf/cm

Figure 4. Removal steps of PCI Express Mini Card for wireless LAN (continued)

Remove the card in the direction shown by arrow **3**.

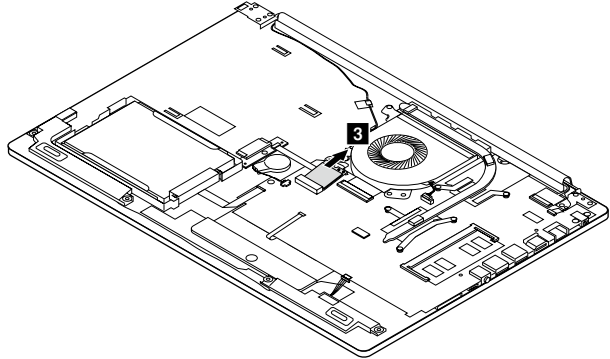

When installing:

- In models with a wireless LAN card that has two antenna connectors, plug the black cable (1st) (MAIN) into the jack labeled **MAIN**, and the grey cable (2nd) (AUX) into the jack labeled **AUX** on the card.
- In models with a wireless LAN card that has three antenna connectors, plug the black cable (1st) (MAIN) into the jack labeled **1**, the grey cable (3rd) into the jack labeled **3**, and the white cable (2nd) (AUX) into the jack labeled **2** on the card.

1050 DIMM

For access, remove these FRUs in order:

- “1010 Optical drive” on page 33
- “1020 Base cover” on page 34
- “1030 Battery pack” on page 37
- “1040 PCI Express Mini Card for wireless LAN” on page 39

Figure 5. Removal steps of DIMM

Release the two latches on both edges of the socket at the same time in the directions shown by arrows **1**, and then unplug the DIMM in the direction shown by arrow **2**.

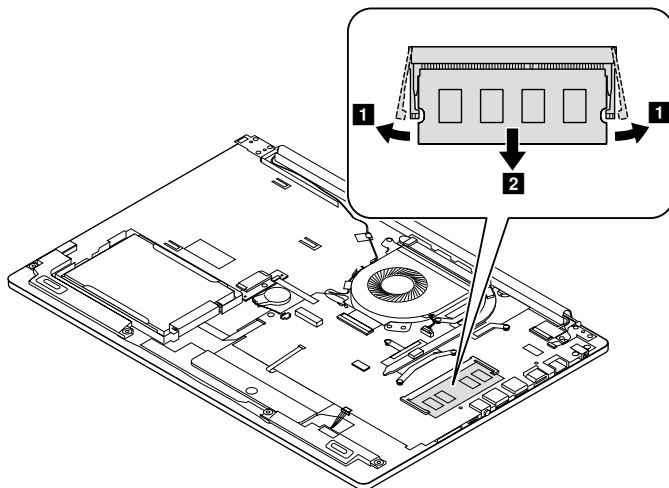

1060 Hard disk drive

For access, remove these FRUs in order:

- “1010 Optical drive” on page 33
- “1020 Base cover” on page 34
- “1030 Battery pack” on page 37
- “1040 PCI Express Mini Card for wireless LAN” on page 39
- “1050 DIMM” on page 41

Attention:

- **Do not drop the hard disk drive or apply any physical shock to it.** The hard disk drive is sensitive to physical shock. Improper handling can cause damage and permanent loss of data.
- Before removing the drive, suggest the customer to backup all the information on it if possible.
- Never remove the drive while the system is operating or in suspend mode.

Figure 6. Removal steps of hard disk drive

Remove the hard disk drive from the slot in the direction shown by arrow **1**.

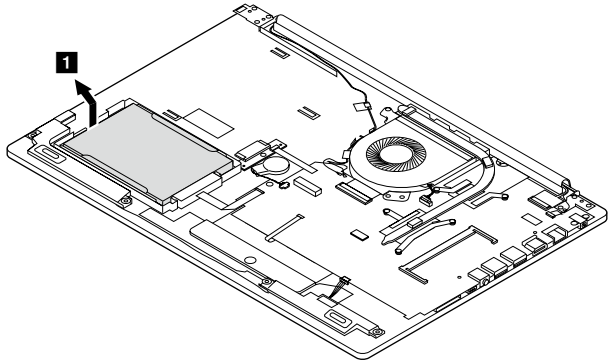

Lenovo ideapad 320-15ISK/ideapad 320H-15ISK/ideapad 320L-15ISK/ideapad 320R-15ISK/ideapad 320E-15ISK/ideapad 320-15IKB/ideapad 320H-15IKB/ideapad 320L-15IKB/ideapad 320R-15IKB/ideapad 320E-15IKB/ideapad 320-15IKB Touch

Figure 6. Removal steps of hard disk drive (continued)

Detach the HDD board connector in the direction shown by arrows **2** and **3**.
Remove the HDD board **4**.

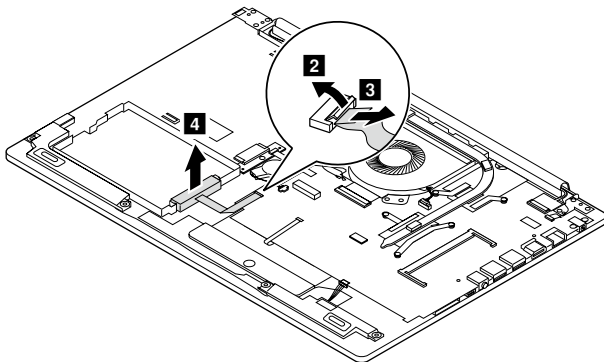

When installing: Make sure that the HDD connector is attached firmly.

Detach the bracket from the hard disk drive.

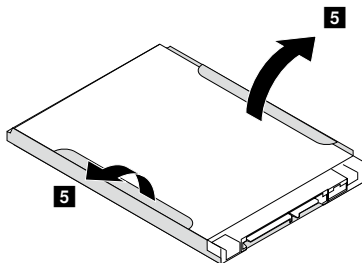

1070 Speakers

For access, remove these FRUs in order:

- “1010 Optical drive” on page 33
- “1020 Base cover” on page 34
- “1030 Battery pack” on page 37
- “1040 PCI Express Mini Card for wireless LAN” on page 39
- “1050 DIMM” on page 41
- “1060 Hard disk drive” on page 42

Figure 7. Removal steps of speakers

Unplug the speaker connector **1**. Then remove the speakers **2**.

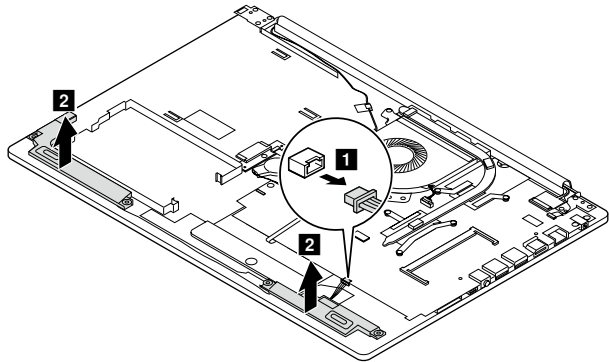

When installing: Make sure that the connector is attached firmly.

Lenovo ideapad 320-15ISK/ideapad 320H-15ISK/ideapad 320L-15ISK/ideapad 320R-15ISK/ideapad 320E-15ISK/ideapad 320-15IKB/ideapad 320H-15IKB/ideapad 320L-15IKB/ideapad 320R-15IKB/ideapad 320E-15IKB/ideapad 320-15IKB Touch

1080 Fan assembly and Heat Sink assembly

For access, remove these FRUs in order:

- “1010 Optical drive” on page 33
- “1020 Base cover” on page 34
- “1030 Battery pack” on page 37
- “1040 PCI Express Mini Card for wireless LAN” on page 39
- “1050 DIMM” on page 41
- “1060 Hard disk drive” on page 42
- “1070 Speakers” on page 44

Figure 8. Removal steps of fan assembly and Heat Sink assembly

Release the cables from the cable guides in the direction shown by arrows ■.

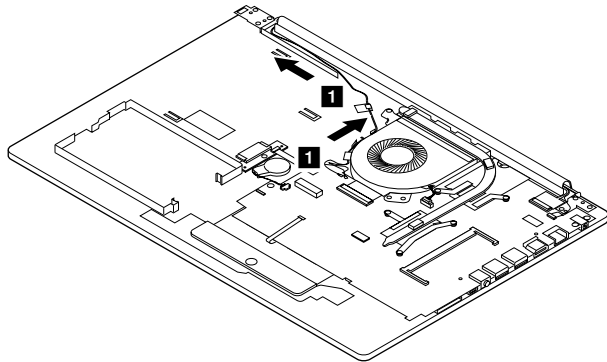

When installing: Route the antenna cables along the cable guides. As you route the cables, make sure that they are not subjected to any tension. Tension could cause the cables to be damaged by the cable guides, or a wire to be broken.

Figure 8. Removal steps of fan assembly and Heat Sink assembly (continued)

Unplug the fan connector in the direction shown by arrow **2**. Remove the screw **3**.

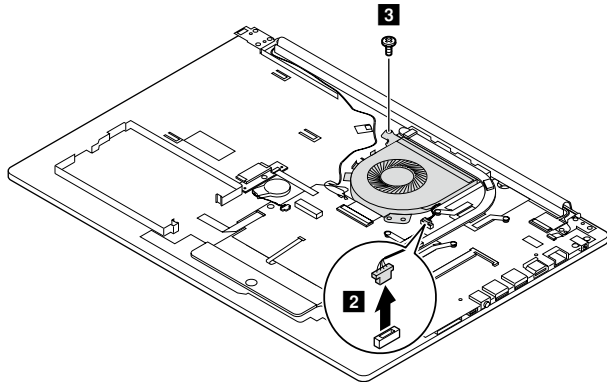

Step	Screw (quantity)	Color	Torque
3	M2 × 6 mm, Phillips head, nylok-coated (1) fan---mb---log up & fan---log up	Black	1.85+/-0.15 kgf/cm

When installing: Make sure that the connector is attached firmly.

Remove the fan in the direction shown by arrow **4**. Be careful not to damage the connector.

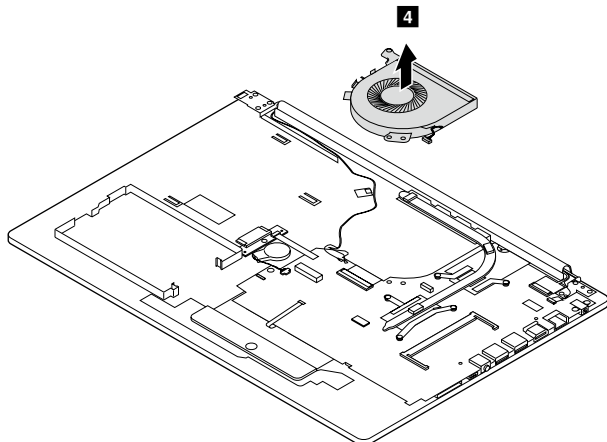

Lenovo ideapad 320-15ISK/ideapad 320H-15ISK/ideapad 320L-15ISK/ideapad 320R-15ISK/ideapad 320E-15ISK/ideapad 320-15IKB/ideapad 320H-15IKB/ideapad 320L-15IKB/ideapad 320R-15IKB/ideapad 320E-15IKB/ideapad 320-15IKB Touch

Figure 8. Removal steps of fan assembly and Heat Sink assembly (continued)

Remove the screws **5**.

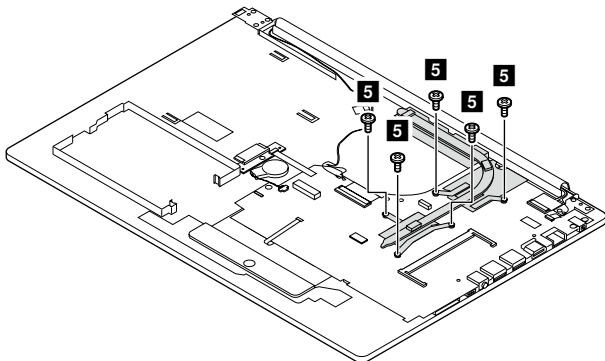

Lift the heat sink in the direction shown by arrows **6**.

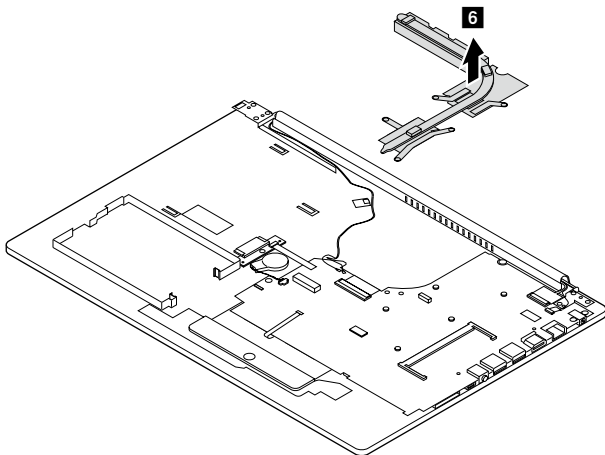
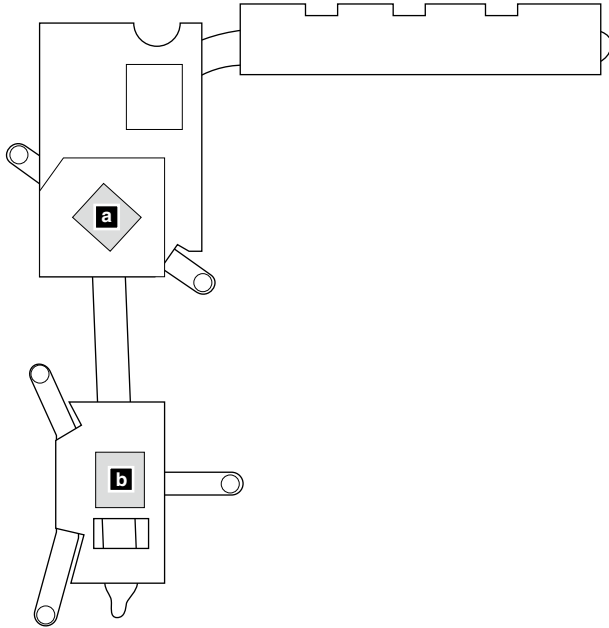

Figure 8. Removal steps of fan assembly and Heat Sink assembly (continued)



When installing: Before you attach the fan assembly to the computer, apply thermal grease, at an amount of 0.2 grams, to the **a b** part shown in the figure above. Either too much or too little grease application can cause a thermal problem due to imperfect contact with a component.

1090 ODD transfer board, backup battery and Fingerprint board

For access, remove these FRUs in order:

- “1010 Optical drive” on page 33
- “1020 Base cover” on page 34
- “1030 Battery pack” on page 37
- “1040 PCI Express Mini Card for wireless LAN” on page 39
- “1050 DIMM” on page 41
- “1060 Hard disk drive” on page 42
- “1070 Speakers” on page 44
- “1080 Fan assembly and Heat Sink assembly” on page 45

Figure 9. Removal steps of ODD transfer board, backup battery and Fingerprint board

Detach the system board connector in the directions shown by arrows **1** and **2**. Unplug the backup battery connector in the direction shown by arrow **3**. Remove the screw **4**. Remove the ODD transfer board in the direction shown by arrow **5**.

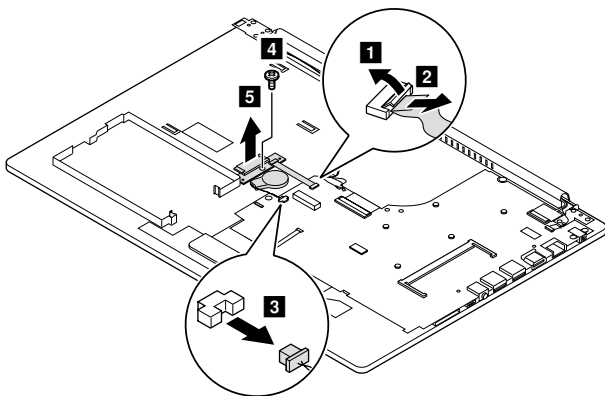

Step	Screw (quantity)	Color	Torque
4	M2 × 3 mm, Phillips-head, nylok-coated (1)	Black	1.85+/-0.15 kgf/cm

When installing: Make sure that the connectors are attached firmly.

Figure 9. Removal steps of ODD transfer board, backup battery and Fingerprint board (continued)

Remove the backup battery in the direction shown by arrow **6**.

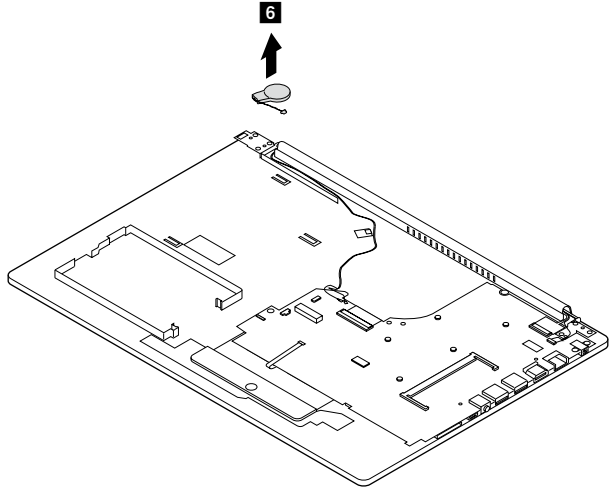

When installing: Make sure that the connector is attached firmly.

1100 Upper case

For access, remove these FRUs in order:

- “1010 Optical drive” on page 33
- “1020 Base cover” on page 34
- “1030 Battery pack” on page 37
- “1040 PCI Express Mini Card for wireless LAN” on page 39
- “1050 DIMM” on page 41
- “1060 Hard disk drive” on page 42
- “1070 Speakers” on page 44
- “1080 Fan assembly and Heat Sink assembly” on page 45
- “1090 ODD transfer board, backup battery and Fingerprint board” on page 49

Figure 10. Removal steps of upper case

Remove the screws ■.

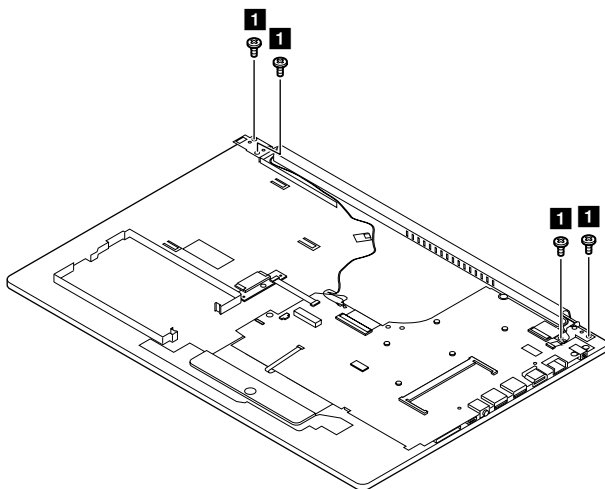

Step	Screw (quantity)	Color	Torque
■	M2.5 × 5 mm, Phillips-head, nylok-coated (4) left side hinge---log up & right side hinge---log up	Silver	3 +/-0.3 kgf/cm

Figure 10. Removal steps of upper case (continued)

Detach the LCD unit connectors in the directions shown by arrows **2** to **4**.

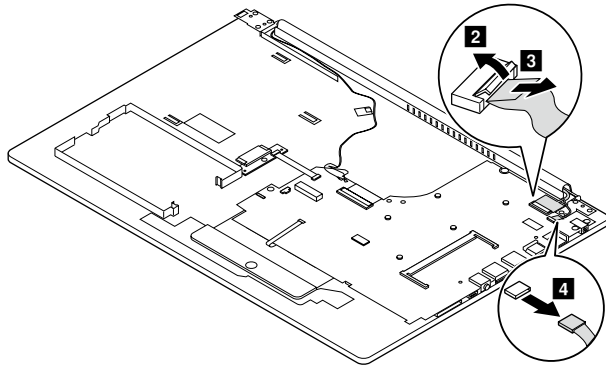

Open the hinge in the direction shown by arrows **5**.

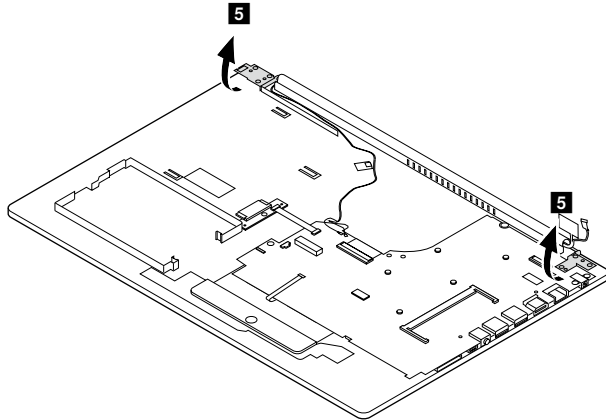

Lenovo ideapad 320-15ISK/ideapad 320H-15ISK/ideapad 320L-15ISK/ideapad 320R-15ISK/ideapad 320E-15ISK/ideapad 320-15IKB/ideapad 320H-15IKB/ideapad 320L-15IKB/ideapad 320R-15IKB/ideapad 320E-15IKB/ideapad 320-15IKB Touch

Figure 10. Removal steps of upper case (continued)

Remove the upper case from the LCD module in the directions shown by arrow **6**.

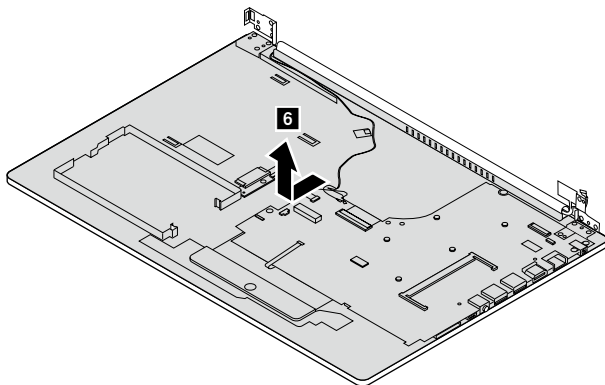

1110 System board

Important notices for handling the system board:

When handling the system board, bear the following in mind.

- Be careful not to drop the system board on a bench top that has a hard surface, such as metal, wood, or composite.
- Avoid rough handling of any kind.
- During the whole process, make sure not to drop or stack the system board.
- If you put a system board down, make sure to put it only on a padded surface such as an ESD mat or conductive corrugated material.

For access, remove these FRUs in order:

- “1010 Optical drive” on page 33
- “1020 Base cover” on page 34
- “1030 Battery pack” on page 37
- “1040 PCI Express Mini Card for wireless LAN” on page 39
- “1050 DIMM” on page 41
- “1060 Hard disk drive” on page 42
- “1070 Speakers” on page 44
- “1080 Fan assembly and Heat Sink assembly” on page 45
- “1090 ODD transfer board, backup battery and Fingerprint board” on page 49
- “1100 Upper case” on page 51

Figure 11. Removal steps of system board

Disconnect the connectors in the directions shown by arrows **1** and **2**. Then remove the screws **3**.

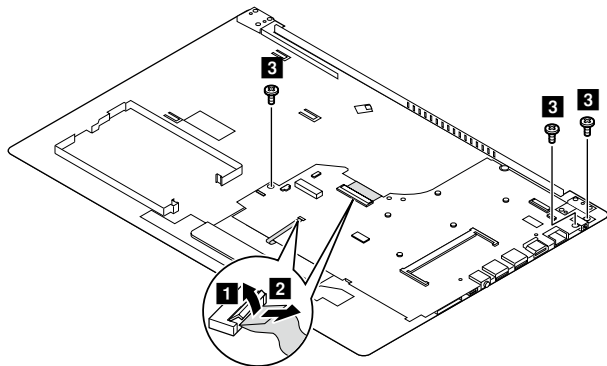

Step	Screw (quantity)	Color	Torque
5	M2 × 3 mm, Phillips-head, nylok-coated (3) M/B---log up	Black	1.85+/-0.15 kgf/cm

Lenovo ideapad 320-15ISK/ideapad 320H-15ISK/ideapad 320L-15ISK/ideapad 320R-15ISK/ideapad 320E-15ISK/ideapad 320-15IKB/ideapad 320H-15IKB/ideapad 320L-15IKB/ideapad 320R-15IKB/ideapad 320E-15IKB/ideapad 320-15IKB Touch

Figure 11. Removal steps of system board (continued)

Remove the system board in the direction shown by arrow **4**.

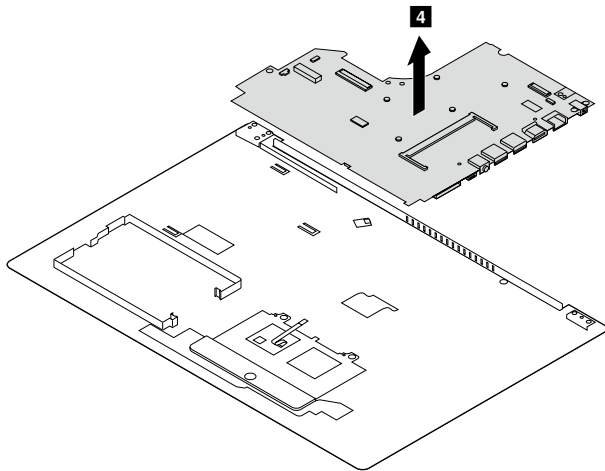

1120 LCD unit

For access, remove these FRUs in order:

- “1010 Optical drive” on page 33
- “1020 Base cover” on page 34
- “1030 Battery pack” on page 37
- “1040 PCI Express Mini Card for wireless LAN” on page 39
- “1050 DIMM” on page 41
- “1060 Hard disk drive” on page 42
- “1070 Speakers” on page 44
- “1080 Fan assembly and Heat Sink assembly” on page 45
- “1090 ODD transfer board, backup battery and Fingerprint board” on page 49
- “1100 Upper case” on page 51
- “1110 System board” on page 54

Figure 12. Removal steps of LCD unit

Pull the hinge cap to the right side to release the hooks.

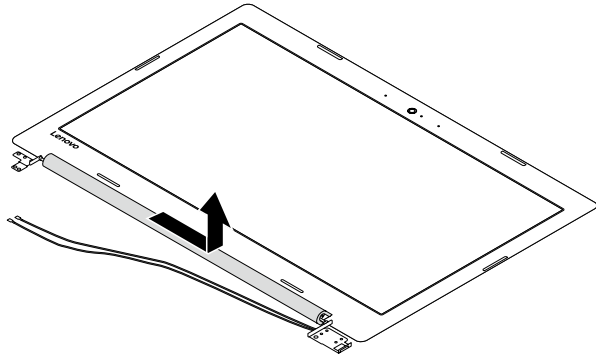

Lenovo ideapad 320-15ISK/ideapad 320H-15ISK/ideapad 320L-15ISK/ideapad 320R-15ISK/ideapad 320E-15ISK/ideapad 320-15IKB/ideapad 320H-15IKB/ideapad 320L-15IKB/ideapad 320R-15IKB/ideapad 320E-15IKB/ideapad 320-15IKB Touch

Figure 12. Removal steps of LCD unit (continued)

Remove the LCD front bezel in the direction shown by arrows 1.

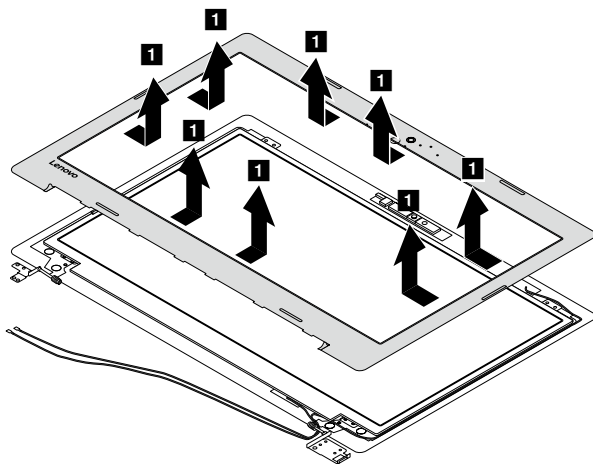

Remove the screws 2. Lift the LCD module slightly 3. Disconnect the connector in the direction shown by arrow 4. Then remove the LCD module.

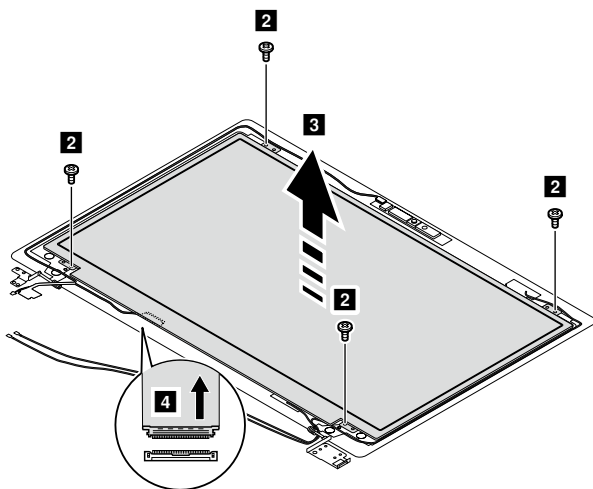

Step	Screw (quantity)	Color	Torque
4	M2 × 3 mm, Phillips-head, nylok-coated (4) lcd panel--lcd cover	Black	1.85+/-0.15 kgf/cm

Figure 12. Removal steps of LCD unit (continued)

Remove the screws **5**.

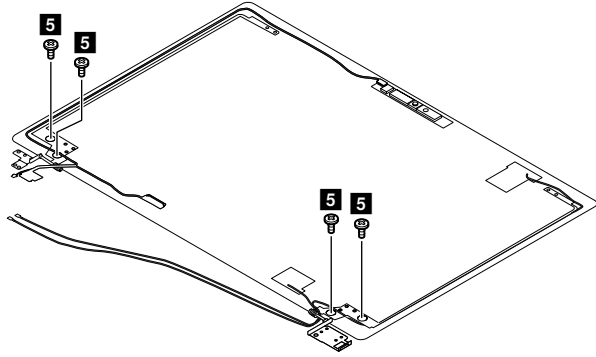

Step	Screw (quantity)	Color	Torque
3	M2.5 × 2.5 mm, Phillips-head, nylok-coated (4) lcd brk---lcd cover	Black	3+/-0.3 kgf/cm

Remove the LCD hinges in the direction shown by arrows **6**.

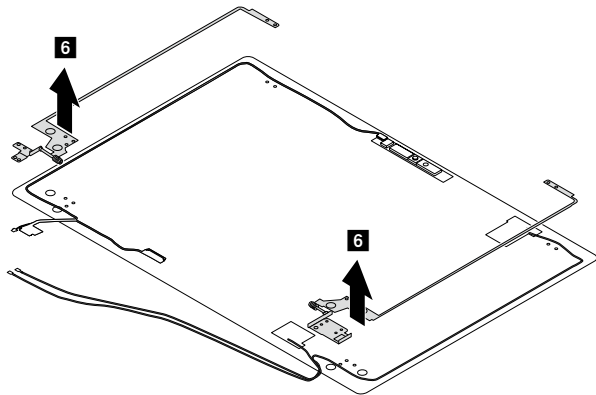

Lenovo ideapad 320-15ISK/ideapad 320H-15ISK/ideapad 320L-15ISK/ideapad 320R-15ISK/ideapad 320E-15ISK/ideapad 320-15IKB/ideapad 320H-15IKB/ideapad 320L-15IKB/ideapad 320R-15IKB/ideapad 320E-15IKB/ideapad 320-15IKB Touch

Figure 12. Removal steps of LCD unit (continued)

Detach the camera connector in the direction shown by arrow **1**.

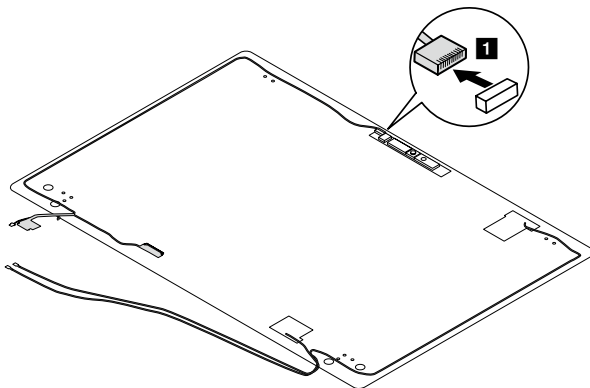

Remove the LCD cable in the direction shown by arrows **2**.

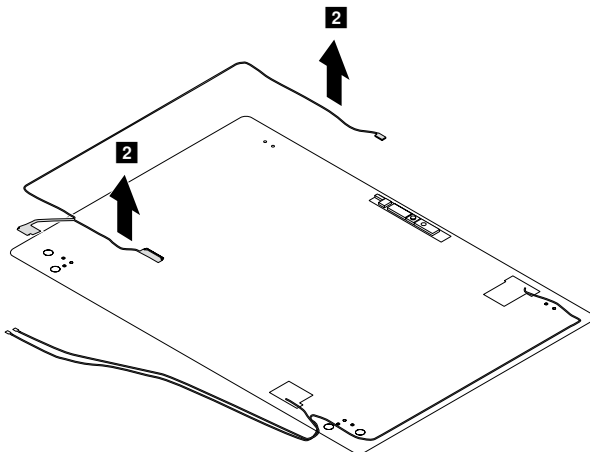

When installing: Make sure that the connector is attached firmly and that you do not pinch the antenna cables when you attach the LCD assembly. Route the LCD cable along the cable guides.

Figure 12. Removal steps of LCD unit (continued)

Peel off the adhesive tape securing the antenna boards, release the cables from the cable guide, and then remove the antenna assembly in the direction shown by arrows **3**.

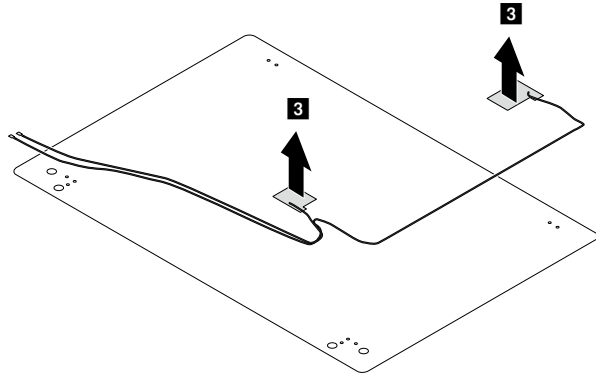

Lenovo ideapad 320-15ISK/ideapad 320H-15ISK/ideapad 320L-15ISK/ideapad 320R-15ISK/ideapad 320E-15ISK/ideapad 320-15IKB/ideapad 320H-15IKB/ideapad 320L-15IKB/ideapad 320R-15IKB/ideapad 320E-15IKB/ideapad 320-15IKB Touch

1130 Integrated camera and antenna assembly

For access, remove these FRUs in order:

- “1010 Optical drive” on page 33
- “1020 Base cover” on page 34
- “1030 Battery pack” on page 37
- “1040 PCI Express Mini Card for wireless LAN” on page 39
- “1050 DIMM” on page 41
- “1060 Hard disk drive” on page 42
- “1070 Speakers” on page 44
- “1080 Fan assembly and Heat Sink assembly” on page 45
- “1090 ODD transfer board, backup battery and Fingerprint board” on page 49
- “1100 Upper case” on page 51
- “1110 System board” on page 54
- “1120 LCD unit” on page 56

Figure 13. Removal steps of integrated camera and antenna assembly

Note: The integrated camera is stuck on the top center of the LCD cover.

Remove the integrated camera in the direction shown by arrow ■.

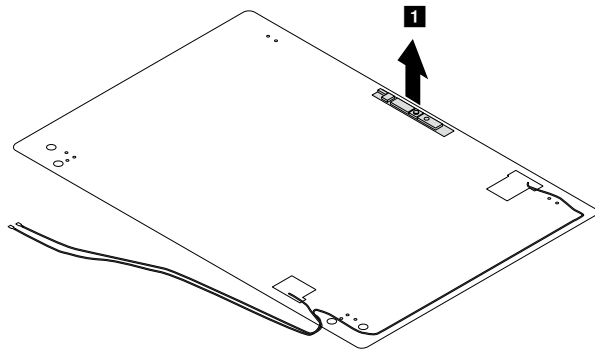

When installing: Stick the integrated camera to the top center of the LCD cover and adjust its placement to make sure the connector is attached firmly.

Locations

Front view and right-side view

- Integrated camera
- 2 Built-in microphone
- 3 Computer display
- 4 Wireless LAN antennas
- 5 Power Key
- 6 Touch pad
- 7 Fingerprint reader (on select models)
- 8 Optical disc drive
- 9 Kensington Security slot

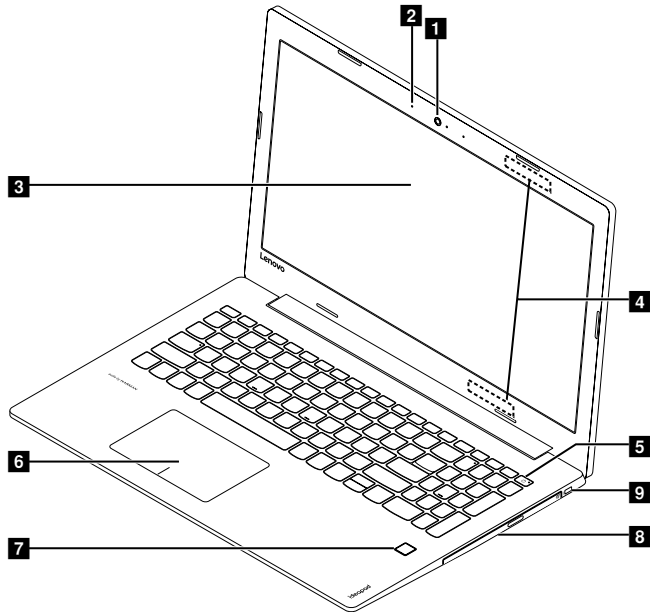

Lenovo ideapad 320-15ISK/ideapad 320H-15ISK/ideapad 320L-15ISK/ideapad 320R-15ISK/ideapad 320E-15ISK/ideapad 320-15IKB/ideapad 320H-15IKB/ideapad 320L-15IKB/ideapad 320R-15IKB/ideapad 320E-15IKB/ideapad 320-15IKB Touch

Bottom and Left-side view

- Speakers
- 2 Ventilation slots
- 3 AC power adapter jack
- 4 Battery/Charging status indicator
- 5 RJ-45 port
- 6 HDMI port
- 7 USB 3.0 port
- 8 Combo audio jack
- 9 Type-C port
- 10 Memory card slot
- 11 Novo button
- 12 Power status indicator

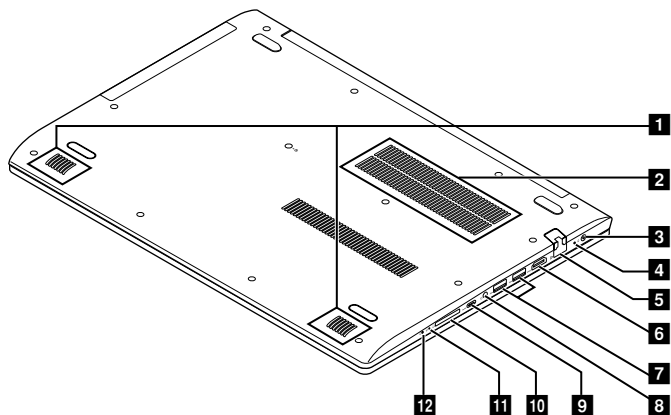

Parts list

This section presents the following service parts:

- “Overall” on page 65
- “LCD FRUs” on page 74
- “Miscellaneous parts” on page 76
- “AC adapters” on page 76
- “Screws” on page 78

Note:

Each FRU is available for all types or models, unless specific types or models are specified.

Attention:

Do not attempt to replace an FRU on your own. If an FRU is damaged, contact a Lenovo authorized servicer or a marketing representative for replacement or repair. Only qualified technicians can inspect or repair this product.

Lenovo ideapad 320-15ISK/ideapad 320H-15ISK/ideapad 320L-15ISK/ideapad 320R-15ISK/ideapad 320E-15ISK/ideapad 320-15IKB/ideapad 320H-15IKB/ideapad 320L-15IKB/ideapad 320R-15IKB/ideapad 320E-15IKB/ideapad 320-15IKB Touch

Overall

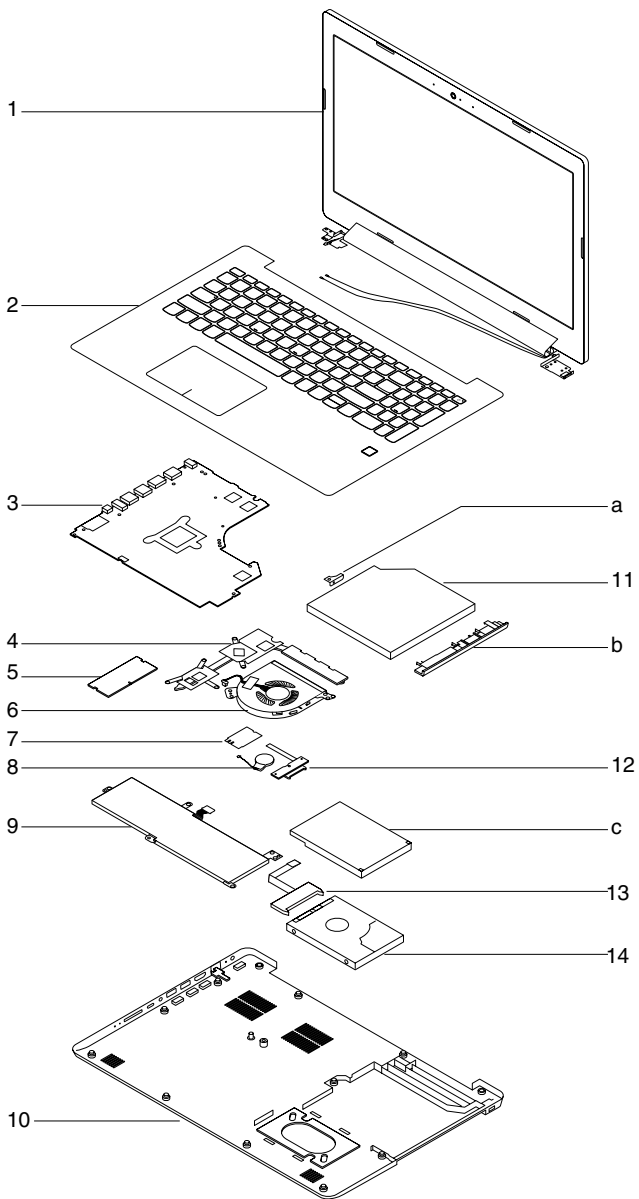

Table 4. Parts list—Overall

No.	FRU	FRU no.	CRU ID.
a-c	See "Miscellaneous parts" on page 76.		
1	LCD unit (see "LCD FRUs" on page 74).		
2	UPPERCASEASML80XLWH IMR US KB	5CB0N86409	N
2	UPPERCASEASML80XLWH IMR UK KB	5CB0N86306	
2	UPPERCASEASML80XLWH IMR ITA KB	5CB0N86346	
2	UPPERCASEASML80XLWH IMR SPA KB	5CB0N86528	
2	UPPERCASEASML80XLWH IMR TUR KB	5CB0N86441	
2	UPPERCASEASML80XLWH IMR THA KB	5CB0N86401	
2	UPPERCASEASML80XLWH IMR POR KB	5CB0N86554	
2	UPPERCASEASML80XLWH IMR LSP KB	5CB0N86465	
2	UPPERCASEASML80XLWH IMR CFEN KB	5CB0N86351	
2	UPPERCASEASML80XLWH IMR KOR KB	5CB0N86619	
2	UPPERCASEASML80XLWH IMR TC KB	5CB0N86543	
2	UPPERCASEASML80XLWH IMR RU KB	5CB0N86584	
2	UPPERCASEASML80XLWH IMR FR KB	5CB0N86387	
2	UPPERCASEASML80XLWH IMR GE KB	5CB0N86288	
2	UPPERCASEASML80XLWH IMR ARA KB	5CB0N86480	
2	UPPERCASEASML80XLWH IMR JP KB	5CB0N86458	
2	UPPERCASEASML80XLWH IMR BRA KB	5CB0N86367	
2	UPPERCASEASML80XLWH IMR DUTCH KB	5CB0N86398	
2	UPPERCASEASML80XLWH IMR GRE KB	5CB0N86420	
2	UPPERCASEASML80XLWH IMR HEB KB	5CB0N86611	
2	UPPERCASEASML80XLWH IMR HUN KB	5CB0N86527	
2	UPPERCASEASML80XLWH IMR NORDIC KB	5CB0N86575	
2	UPPERCASEASML80XLWH IMR BEL KB	5CB0N86275	
2	UPPERCASEASML80XLWH IMR IL KB	5CB0N86457	
2	UPPERCASEASML80XLWH IMR SLE KB	5CB0N86585	
2	UPPERCASEASML80XLWH IMR SWS KB	5CB0N86391	
2	UPPERCASEASML80XLWH IMR USINT KB	5CB0N86384	
2	UPPERCASEASML80XLWH IMR CZHSLK KB	5CB0N86555	
2	UPPERCASEASML80XLWH IMR BUL KB	5CB0N86537	
2	UPPERCASEASML80XLWH IMR INDIA KB	5CB0N86302	
2	UPPERCASEASML80XLWH IMR FRAR KB	5CB0N86483	
2	UPPERCASEASML80XLWH IMR UKR KB	5CB0N86304	
2	UPPERCASEASML80XLPG IMR US KB	5CB0N86311	
2	UPPERCASEASML80XLPG IMR UK KB	5CB0N86475	
2	UPPERCASEASML80XLPG IMR ITA KB	5CB0N86435	
2	UPPERCASEASML80XLPG IMR SPA KB	5CB0N86375	
2	UPPERCASEASML80XLPG IMR TUR KB	5CB0N86357	
2	UPPERCASEASML80XLPG IMR THA KB	5CB0N86447	
2	UPPERCASEASML80XLPG IMR POR KB	5CB0N86476	
2	UPPERCASEASML80XLPG IMR LSP KB	5CB0N86512	
2	UPPERCASEASML80XLPG IMR CFEN KB	5CB0N86428	
2	UPPERCASEASML80XLPG IMR KOR KB	5CB0N86532	
2	UPPERCASEASML80XLPG IMR TC KB	5CB0N86438	
2	UPPERCASEASML80XLPG IMR RU KB	5CB0N86294	
2	UPPERCASEASML80XLPG IMR FR KB	5CB0N86629	

Lenovo ideapad 320-15ISK/ideapad 320H-15ISK/ideapad 320L-15ISK/ideapad 320R-15ISK/ideapad 320E-15ISK/ideapad 320-15IKB/ideapad 320H-15IKB/ideapad 320L-15IKB/ideapad 320R-15IKB/ideapad 320E-15IKB/ideapad 320-15IKB Touch

Table 4. Parts list—Overall (continued)

No.	FRU	FRU no.	CRU ID.
2	UPPERCASEASML80XLPG IMR GE KB	5CB0N86432	N
2	UPPERCASEASML80XLPG IMR ARA KB	5CB0N86317	
2	UPPERCASEASML80XLPG IMR JP KB	5CB0N86563	
2	UPPERCASEASML80XLPG IMR BRAKB	5CB0N86439	
2	UPPERCASEASML80XLPG IMR DUTCH KB	5CB0N86454	
2	UPPERCASEASML80XLPG IMR GRE KB	5CB0N86573	
2	UPPERCASEASML80XLPG IMR HEB KB	5CB0N86269	
2	UPPERCASEASML80XLPG IMR HUN KB	5CB0N86411	
2	UPPERCASEASML80XLPG IMR NORDIC KB	5CB0N86320	
2	UPPERCASEASML80XLPG IMR BEL KB	5CB0N86490	
2	UPPERCASEASML80XLPG IMR IL KB	5CB0N86266	
2	UPPERCASEASML80XLPG IMR SLE KB	5CB0N86265	
2	UPPERCASEASML80XLPG IMR SWS KB	5CB0N86605	
2	UPPERCASEASML80XLPG IMR USINT KB	5CB0N86407	
2	UPPERCASEASML80XLPG IMR CZHSLK KB	5CB0N86517	
2	UPPERCASEASML80XLPG IMR BUL KB	5CB0N86382	
2	UPPERCASEASML80XLPG IMR INDIA KB	5CB0N86292	
2	UPPERCASEASML80XLPG IMR FRAR KB	5CB0N86326	
2	UPPERCASEASML80XLPG IMR UKR KB	5CB0N86389	
2	UPPERCASEASML80XLIG IMR US KB	5CB0N86581	
2	UPPERCASEASML80XLIG IMR UK KB	5CB0N86316	
2	UPPERCASEASML80XLIG IMR ITA KB	5CB0N86464	
2	UPPERCASEASML80XLIG IMR SPA KB	5CB0N86578	
2	UPPERCASEASML80XLIG IMR TUR KB	5CB0N86547	
2	UPPERCASEASML80XLIG IMR THA KB	5CB0N86287	
2	UPPERCASEASML80XLIG IMR POR KB	5CB0N86277	
2	UPPERCASEASML80XLIG IMR LSP KB	5CB0N86502	
2	UPPERCASEASML80XLIG IMR CFEN KB	5CB0N86588	
2	UPPERCASEASML80XLIG IMR KOR KB	5CB0N86522	
2	UPPERCASEASML80XLIG IMR TC KB	5CB0N86291	
2	UPPERCASEASML80XLIG IMR RU KB	5CB0N86582	
2	UPPERCASEASML80XLIG IMR FR KB	5CB0N86307	
2	UPPERCASEASML80XLIG IMR GE KB	5CB0N86425	
2	UPPERCASEASML80XLIG IMR ARA KB	5CB0N86262	
2	UPPERCASEASML80XLIG IMR JP KB	5CB0N86456	
2	UPPERCASEASML80XLIG IMR BRA KB	5CB0N86390	
2	UPPERCASEASML80XLIG IMR DUTCH KB	5CB0N86308	
2	UPPERCASEASML80XLIG IMR GRE KB	5CB0N86488	
2	UPPERCASEASML80XLIG IMR HEB KB	5CB0N86487	
2	UPPERCASEASML80XLIG IMR HUN KB	5CB0N86587	
2	UPPERCASEASML80XLIG IMR NORDIC KB	5CB0N86484	
2	UPPERCASEASML80XLIG IMR BEL KB	5CB0N86574	
2	UPPERCASEASML80XLIG IMR IL KB	5CB0N86303	
2	UPPERCASEASML80XLIG IMR SLE KB	5CB0N86608	
2	UPPERCASEASML80XLIG IMR SWS KB	5CB0N86529	
2	UPPERCASEASML80XLIG IMR USINT KB	5CB0N86449	
2	UPPERCASEASML80XLIG IMR CZHSLK KB	5CB0N86336	

Table 4. Parts list—Overall (continued)

No.	FRU	FRU no.	CRU ID.
2	UPPERCASEASML80XLIG IMR BUL KB	5CB0N86540	N
2	UPPERCASEASML80XLIG IMR INDIA KB	5CB0N86542	
2	UPPERCASEASML80XLIG IMR FRAR KB	5CB0N86403	
2	UPPERCASEASML80XLIG IMR UKR KB	5CB0N86282	
2	UPPERCASEASML80XLLL IMR US KB	5CB0N86379	
2	UPPERCASEASML80XLLL IMR UK KB	5CB0N86342	
2	UPPERCASEASML80XLLL IMR ITA KB	5CB0N86491	
2	UPPERCASEASML80XLLL IMR SPA KB	5CB0N86519	
2	UPPERCASEASML80XLLL IMR TUR KB	5CB0N86576	
2	UPPERCASEASML80XLLL IMR THA KB	5CB0N86285	
2	UPPERCASEASML80XLLL IMR POR KB	5CB0N86310	
2	UPPERCASEASML80XLLL IMR LSP KB	5CB0N86348	
2	UPPERCASEASML80XLLL IMR CFEN KB	5CB0N86546	
2	UPPERCASEASML80XLLL IMR KOR KB	5CB0N86600	
2	UPPERCASEASML80XLLL IMR TC KB	5CB0N86408	
2	UPPERCASEASML80XLLL IMR RU KB	5CB0N86622	
2	UPPERCASEASML80XLLL IMR FR KB	5CB0N86592	
2	UPPERCASEASML80XLLL IMR GE KB	5CB0N86365	
2	UPPERCASEASML80XLLL IMR ARA KB	5CB0N86590	
2	UPPERCASEASML80XLLL IMR JP KB	5CB0N86296	
2	UPPERCASEASML80XLLL IMR BRA KB	5CB0N86586	
2	UPPERCASEASML80XLLL IMR DUTCH KB	5CB0N86539	
2	UPPERCASEASML80XLLL IMR GRE KB	5CB0N86631	
2	UPPERCASEASML80XLLL IMR HEB KB	5CB0N86520	
2	UPPERCASEASML80XLLL IMR HUN KB	5CB0N86501	
2	UPPERCASEASML80XLLL IMR NORDIC KB	5CB0N86616	
2	UPPERCASEASML80XLLL IMR BEL KB	5CB0N86440	
2	UPPERCASEASML80XLLL IMR IL KB	5CB0N86505	
2	UPPERCASEASML80XLLL IMR SLE KB	5CB0N86572	
2	UPPERCASEASML80XLLL IMR SWS KB	5CB0N86430	
2	UPPERCASEASML80XLLL IMR USINT KB	5CB0N86368	
2	UPPERCASEASML80XLLL IMR CZHSLK KB	5CB0N86323	
2	UPPERCASEASML80XLLL IMR BUL KB	5CB0N86371	
2	UPPERCASEASML80XLLL IMR INDIA KB	5CB0N86332	
2	UPPERCASEASML80XLLL IMR FRAR KB	5CB0N86536	
2	UPPERCASEASML80XLLL IMR UKR KB	5CB0N86388	
2	UPPERCASEASML80XLIB IMR US KB	5CB0N86404	
2	UPPERCASEASML80XLIB IMR UK KB	5CB0N86567	
2	UPPERCASEASML80XLIB IMR ITA KB	5CB0N86604	
2	UPPERCASEASML80XLIB IMR SPA KB	5CB0N86609	
2	UPPERCASEASML80XLIB IMR TUR KB	5CB0N86615	
2	UPPERCASEASML80XLIB IMR THA KB	5CB0N86322	
2	UPPERCASEASML80XLIB IMR POR KB	5CB0N86455	
2	UPPERCASEASML80XLIB IMR LSP KB	5CB0N86354	
2	UPPERCASEASML80XLIB IMR CFEN KB	5CB0N86318	
2	UPPERCASEASML80XLIB IMR KOR KB	5CB0N86345	
2	UPPERCASEASML80XLIB IMR TC KB	5CB0N86548	

Lenovo ideapad 320-15ISK/ideapad 320H-15ISK/ideapad 320L-15ISK/ideapad 320R-15ISK/ideapad 320E-15ISK/ideapad 320-15IKB/ideapad 320H-15IKB/ideapad 320L-15IKB/ideapad 320R-15IKB/ideapad 320E-15IKB/ideapad 320-15IKB Touch

Table 4. Parts list—Overall (continued)

No.	FRU	FRU no.	CRU ID.
2	UPPERCASEASML80XLIB IMR RU KB	5CB0N86383	N
2	UPPERCASEASML80XLIB IMR FR KB	5CB0N86281	
2	UPPERCASEASML80XLIB IMR GE KB	5CB0N86393	
2	UPPERCASEASML80XLIB IMR ARA KB	5CB0N86374	
2	UPPERCASEASML80XLIB IMR JP KB	5CB0N86363	
2	UPPERCASEASML80XLIB IMR BRA KB	5CB0N86497	
2	UPPERCASEASML80XLIB IMR DUTCH KB	5CB0N86305	
2	UPPERCASEASML80XLIB IMR GRE KB	5CB0N86446	
2	UPPERCASEASML80XLIB IMR HEB KB	5CB0N86448	
2	UPPERCASEASML80XLIB IMR HUN KB	5CB0N86421	
2	UPPERCASEASML80XLIB IMR NORDIC KB	5CB0N86550	
2	UPPERCASEASML80XLIB IMR BEL KB	5CB0N86337	
2	UPPERCASEASML80XLIB IMR IL KB	5CB0N86506	
2	UPPERCASEASML80XLIB IMR SLE KB	5CB0N86417	
2	UPPERCASEASML80XLIB IMR SWS KB	5CB0N86499	
2	UPPERCASEASML80XLIB IMR USINT KB	5CB0N86309	
2	UPPERCASEASML80XLIB IMR CZHSLK KB	5CB0N86312	
2	UPPERCASEASML80XLIB IMR BUL KB	5CB0N86395	
2	UPPERCASEASML80XLIB IMR INDIA KB	5CB0N86385	
2	UPPERCASEASML80XLIB IMR FRAR KB	5CB0N86511	
2	UPPERCASEASML80XLIB IMR UKR KB	5CB0N86521	
2	UPPERCASEASML80XLRD IMR US KB	5CB0N86509	
2	UPPERCASEASML80XLRD IMR UK KB	5CB0N86343	
2	UPPERCASEASML80XLRD IMR ITA KB	5CB0N86301	
2	UPPERCASEASML80XLRD IMR SPA KB	5CB0N86333	
2	UPPERCASEASML80XLRD IMR TUR KB	5CB0N86315	
2	UPPERCASEASML80XLRD IMR THA KB	5CB0N86284	
2	UPPERCASEASML80XLRD IMR POR KB	5CB0N86415	
2	UPPERCASEASML80XLRD IMR LSP KB	5CB0N86556	
2	UPPERCASEASML80XLRD IMR CFEN KB	5CB0N86493	
2	UPPERCASEASML80XLRD IMR KOR KB	5CB0N86364	
2	UPPERCASEASML80XLRD IMR TC KB	5CB0N86514	
2	UPPERCASEASML80XLRD IMR RU KB	5CB0N86535	
2	UPPERCASEASML80XLRD IMR FR KB	5CB0N86469	
2	UPPERCASEASML80XLRD IMR GE KB	5CB0N86504	
2	UPPERCASEASML80XLRD IMR ARA KB	5CB0N86569	
2	UPPERCASEASML80XLRD IMR JP KB	5CB0N86283	
2	UPPERCASEASML80XLRD IMR BRA KB	5CB0N86353	
2	UPPERCASEASML80XLRD IMR DUTCH KB	5CB0N86270	
2	UPPERCASEASML80XLRD IMR GRE KB	5CB0N86551	
2	UPPERCASEASML80XLRD IMR HEB KB	5CB0N86579	
2	UPPERCASEASML80XLRD IMR HUN KB	5CB0N86297	
2	UPPERCASEASML80XLRD IMR NORDIC KB	5CB0N86500	
2	UPPERCASEASML80XLRD IMR BEL KB	5CB0N86508	
2	UPPERCASEASML80XLRD IMR IL KB	5CB0N86356	
2	UPPERCASEASML80XLRD IMR SLE KB	5CB0N86423	
2	UPPERCASEASML80XLRD IMR SWS KB	5CB0N86340	

Table 4. Parts list—Overall (continued)

No.	FRU	FRU no.	CRU ID.
2	UPPERCASEASML80XLRD IMR USINT KB	5CB0N86626	N
2	UPPERCASEASML80XLRD IMR CZHSLK KB	5CB0N86482	
2	UPPERCASEASML80XLRD IMR BUL KB	5CB0N86596	
2	UPPERCASEASML80XLRD IMR INDIA KB	5CB0N86328	
2	UPPERCASEASML80XLRD IMR FRAR KB	5CB0N86606	
2	UPPERCASEASML80XLRD IMR UKR KB	5CB0N86538	
3	MBL80XHMB241156200UUMAWIN	5B20N86801	
3	MBL80XHMB241156200UUMANOK	5B20N86788	
3	MBL80XHMB241136006UUMA4GWIN	5B20N86787	
3	MBL80XHMB241136006UUMA4GNOK	5B20N86786	
3	MBL80XHMB241176500UUMA4GWIN	5B20N86797	
3	MBL80XHMB241176500UUMA4GNOK	5B20N86791	
3	MBL80XHMB241156200UUMA4GWIN	5B20N86796	
3	MBL80XHMB241156200UUMA4GNOK	5B20N86789	
3	MBL80XHMB241176500UUMAWIN	5B20N86803	
3	MBL80XHMB241176500UUMANOK	5B20N86790	
3	MBL80XHMB242156200UGMR1_2GWIN	5B20N86802	
3	MBL80XHMB242156200UGMR1_2GNOK	5B20N86799	
3	MBL80XHMB242176500UGMR1_2G4GWIN	5B20N86785	
3	MBL80XHMB242176500UGMR1_2G4GNOK	5B20N86793	
3	MBL80XHMB242156200UGMR1_2G4GWIN	5B20N86804	
3	MBL80XHMB242156200UGMR1_2G4GNOK	5B20N86798	
3	MBL80XHMB242136006UGMR1_2G4GWIN	5B20N86794	
3	MBL80XHMB242136006UGMR1_2G4GNOK	5B20N86792	
3	MBL80XHMB242176500UGMR1_2GWIN	5B20N86800	
3	MBL80XHMB242176500UGMR1_2GNOK	5B20N86795	
4	THERMAL MODULE DIS L80XK	5H40N82364	
4	THERMAL MODULE UMA L80XK	5H40N82349	
4	THERMAL MODULE DIS GT3 L80XG For I3-6006U	5H40N87789	
4	THERMAL MODULE UMA GT3 L80XG For I3-6006U	5H40N87790	
5	DDR4 2400 Memroy (ISK and KBL only), On Board DDR4 Memory 8Gb*16, K4A8G165WB-BCRC	SM30L08874	
5	DDR4 2400 Memroy (ISK and KBL only), On Board DDR4 Memory 8Gb*16, H5AN8G6NAFR-UHC	SM30L08875	
5	DDR4 2400 Memroy (ISK and KBL only), On Board DDR4 Memory 8Gb*16, MT40A512M16JY-083E:B	SM30L08877	
5	DDR4 2400 Memroy (ISK and KBL only), 2GB DDR4 2400 SoDIMM, M471A5644EB0-CRC	SM30G16500	
5	DDR4 2400 Memroy (ISK and KBL only), 2GB DDR4 2400 SoDIMM, HMA425S6AFR6N-UH	SM30G16501	
5	DDR4 2400 Memroy (ISK and KBL only), 2GB DDR4 2400 SoDIMM, MTA4ATF25664HZ-2G3B1	SM30G16502	
5	DDR4 2400 Memroy (ISK and KBL only), 2GB DDR4 2400 SoDIMM, RMSA3270MB76H8F-2400	SM30G16503	
5	DDR4 2400 Memroy (ISK and KBL only), 4GB DDR4 2400 SoDIMM, M471A5244CB0-CRC	SM30M49902	
5	DDR4 2400 Memroy (ISK and KBL only), 4GB DDR4 2400 SoDIMM, HMA851S6AFR6N-UH	SM30G16505	

Lenovo ideapad 320-15ISK/ideapad 320H-15ISK/ideapad 320L-15ISK/ideapad 320R-15ISK/ideapad 320E-15ISK/ideapad 320-15IKB/ideapad 320H-15IKB/ideapad 320L-15IKB/ideapad 320R-15IKB/ideapad 320E-15IKB/ideapad 320-15IKB Touch

Table 4. Parts list—Overall (continued)

No.	FRU	FRU no.	CRU ID.
5	DDR4 2400 Memroy (ISK and KBL only), 4GB DDR4 2400 SoDIMM, MTA4ATF51264HZ-2G3B1	SM30G16506	N
5	DDR4 2400 Memroy (ISK and KBL only), 4GB DDR4 2400 SoDIMM, RMSA3270MB86H9F-2400	SM30G16507	
5	DDR4 2400 Memroy (ISK and KBL only), 8GB DDR4 2400 SoDIMM, M471A1K43CB1-CRC	SM30M49901	
5	DDR4 2400 Memroy (ISK and KBL only), 8GB DDR4 2400 SoDIMM, HMA81GS6AFR8N-UH	SM30G16509	
5	DDR4 2400 Memroy (ISK and KBL only), 8GB DDR4 2400 SoDIMM, MTA8ATF1G64HZ-2G3B1	SM30G16510	
5	DDR4 2400 Memroy (ISK and KBL only), 8GB DDR4 2400 SoDIMM, RMSA3260MB78HAF-2400	SM30G16511	
5	DDR4 2400 Memroy (ISK and KBL only), 16GB DDR4 2400 SoDIMM, M471A2K43CB1-CRC	SM30M49903	
5	DDR4 2400 Memroy (ISK and KBL only), 16GB DDR4 2400 SoDIMM, HMA82GS6AFR8N-UH	SM30G16513	
5	DDR4 2400 Memroy (ISK and KBL only), 16GB DDR4 2400 SoDIMM, MTA16ATF2G64H-2G3B1	SM30G16514	
5	DDR3L Memroy (IAP only), 2GB DDR3L SODIMM 1600, M471B5674EB0-YK0 2GB DDR3L 1600	5M30K59779	
5	DDR3L Memroy (IAP only), 2GB DDR3L SODIMM 1600, HMT425S6CFR6A-PB 2GB DDR3L 1600	5M30G99881	
5	DDR3L Memroy (IAP only), 2GB DDR3L SODIMM 1600, RMT3190MP76F8F 2GB DDR3L 1600	SM30M95852	
5	DDR3L Memroy (IAP only), 2GB DDR3L SODIMM 1600, MT4KTF25664HZ-1G9P1 2GB DDR3L 1600	5M30K59781	
5	DDR3L Memroy (IAP only), 4GB DDR3L SODIMM 1600, M471B5173EB0-YK0 4GB DDR3L 1600	5M30G18425	
5	DDR3L Memroy (IAP only), 4GB DDR3L SODIMM 1600, HMT451S6DFR8A-PB 4GB DDR3L 1600	5M30K59780	
5	DDR3L Memroy (IAP only), 4GB DDR3L SODIMM 1600, 4GB D3L S RMT3170MP68F9F-1600	5M30L20980	
5	DDR3L Memroy (IAP only), 4GB DDR3L SODIMM 1600, MT8KTF51264HZ-1G9P1 4GB DDR3L 1600	5M30K59782	
5	DDR3L Memroy (IAP only), 8GB DDR3L SODIMM 1600, M471B1G73EB0-YK0 8GB DDR3L 1600	5M30G18424	
5	DDR3L Memroy (IAP only), 8GB DDR3L SODIMM 1600, HMT41GS6DFR8A-PB 8GB DDR3L 1600	5M30K59783	
5	DDR3L Memroy (IAP only), 8GB DDR3L SODIMM 1600, 8GB D3L S RMT3160MP68FAF-1600	5M30L20981	
5	DDR3L Memroy (IAP only), 8GB DDR3L SODIMM 1600, MT16KTF1G64HZ-1G9P1 8GB DDR3L 1600	5M30K59785	
6	FAN DC5V L80XK	5F10N82225	
7	WLAN, Wifi 1X1 AC+ BT 4.1, Intel 3165 1x1AC+BT PCIE M.2 WLAN	SW10H24486	
7	WLAN, Wifi 1X1 AC+ BT 4.1, Cbt RTL8821AE 1x1AC+BT PCIE M.2 WLAN	SW10A11648	
7	WLAN, Wifi 1X1 AC+ BT 4.1, Ltn NFA435A 1x1AC+BT PCIE M.2 WLAN	SW10K97461	
8	RTC BATTERY L80XK	5B10N82213	
9	Battery, Polymer 30W Normal (15wh* 2cell), 320 SP/A L16M2PB1 7.5V30Wh2cell bty	5B10M86148	

Table 4. Parts list—Overall (continued)

No.	FRU	FRU no.	CRU ID.
9	Battery, Polymer 30W Normal (15wh* 2cell), 320 CP/C L16C2PB2 7.6V30Wh2cell bty	5B10M88058	N
9	Battery, Polymer 30W Normal (15wh* 2cell), 320 LG L16L2PB2 7.4V30Wh2cell bty	5B10M91442	
9	Battery, Polymer 35w Normal (17.5wh *2Cell), 320 SP/A L16M2PB2 7.5V35Wh2cell bty	5B10M86149	
9	Battery, Polymer 35w Normal (17.5wh *2Cell), 320 CP/C L16C2PB1 7.6V35Wh2cell bty	5B10M88059	
9	Battery, Polymer 35w Normal (17.5wh *2Cell), 320 SY L16S2PB1 7.6V35Wh2cell bty	5B10M90490	
9	Battery, Polymer 35w Normal (17.5wh *2Cell), 320 LG L16L2PB3 7.6V35Wh2cell bty	5B10M91443	
10	LOWERCASE L80XL TEX WH	5CB0N86419	
10	LOWERCASE L80XL TEX CG	5CB0N86400	
10	LOWERCASE L80XL TEX LL	5CB0N86625	
10	LOWERCASE L80XL TEX IB	5CB0N86553	
10	LOWERCASE L80XL TEX LCR	5CB0N86376	
11	DUMMY ODD WH L80XK	5M20N82196	*
11	DUMMY ODD CG L80XK	5M20N82244	
11	DUMMY ODD IB L80XL PT	5M20N86344	
11	DUMMY ODD LL L80XL PT	5M20N86533	
11	DUMMY ODD LCR L80XL PT	5M20N86399	
11	DUMMYODD for 2nd HDD WH L80XK	5M20N82228	
11	DUMMYODD for 2nd HDD CG L80XK	5M20N82345	
11	DUMMYODD for 2nd HDD IB L80XK	5M20N82301	
11	DUMMYODDL80XL for2ndHDD LLPT	5M20N86530	
11	DUMMYODDL80XL for2ndHDD LCRPT	5M20N86558	
11	ODD, 9.0mm Rambo ODD, HLDS GUE0N 9.0mm Slim Tray Rambo ODD	5DX0J46488	
11	ODD, 9.0mm Rambo ODD, PLDS DA-8AESH 9.0 mm Slim Tray Rambo ODD	5DX0L08424	
12	ODD BOARD NSB241 L80XL	5C50N86565	
13	HDD BOARD FOR 2ND HDD L80U7	5C50L67280	
14	HDD (7mm), 500G 5400rpm 7mm, ST500LT012 6G 7mm 5.4K 500G HDD	16200383	
14	HDD (7mm), 500G 5400rpm 7mm, MQ01ABF050 6G 7mm 5.4K 500G HDD	5H20L34560	
14	HDD (7mm), 500G 5400rpm 7mm, WD5000LPCX-24VHAT0 7mm 5400rpm 500G HDD	5H20J35762	
14	HDD (7mm), 1TB 5400rpm 7mm, Seagate ST1000LM035 1T 2.5" 7mm 5400rpm HDD	5H20L22184	
14	HDD (7mm), 1TB 5400rpm 7mm, WD10SPCX-24HWST1 6G 7mm 1T HDD	16200554	
14	HDD (7mm), 1TB 5400rpm 7mm, TSB MQ02ABF100 6G 7mm 5.4k 1TB HDD	5H20G09709	
14	HDD (7mm), 2TB 54rpm (7mm), ST Rosewood2D 7mm 2TB HDD	5H20M37521	
14	2.5" Sata, 128G, CV3	5SD0L02317	
14	2.5" Sata, 128G, MZYTY128HDHP-000L2 2.5" 128G 5mm SSD	5SD0L14645	

Lenovo ideapad 320-15ISK/ideapad 320H-15ISK/ideapad 320L-15ISK/ideapad 320R-15ISK/ideapad 320E-15ISK/ideapad 320-15IKB/ideapad 320H-15IKB/ideapad 320L-15IKB/ideapad 320R-15IKB/ideapad 320E-15IKB/ideapad 320-15IKB Touch

Table 4. Parts list—Overall (continued)

No.	FRU	FRU no.	CRU ID.
14	2.5" Sata, 128G, SC308-128 2.5" 5mm 128GB 6Gb/s SATA HFS128G3BTND-N210A SSD	5SD0M38535	N
14	2.5" Sata, 128G, 5mm 128GB 2.5" SATA 6Gb/s RTNRB128RFM2KWDL SSD	5SD0M61138	
14	2.5" Sata, 256G, CV3	5SD0L02316	
14	2.5" Sata, 256G, PM871A	5SD0K93729	
14	2.5" Sata, 256G, SC308-256 2.5" 5mm 256GB 6Gb/s SATA HFS256G3BTND-N210A SSD	5SD0M38533	
14	2.5" Sata, 256G, 5mm 256GB 2.5" SATA 6Gb/s RTNRB128RFM2KWDL SSD	5SD0M61139	
14	2.5" Sata, 512G, CV3	5SD0L02321	
14	2.5" Sata, 512G, MZYTN512HDJH 2.5" 5mmT 512G SSD	5SD0L77695	
14	2.5" Sata, 512G, SC308-512 2.5" 5mm 512GB 6Gb/s SATA HFS512G3BTND-N210A SSD	5SD0M38534	
—	AC adapter (see "AC adapters" on page 76).		

LCD FRUs

In Lenovo ideapad 320-15ISK/ideapad 320H-15ISK/ideapad 320L-15ISK/
ideapad 320R-15ISK/ideapad 320E-15ISK/ideapad 320-15IKB/ideapad
320H-15IKB/ideapad 320L-15IKB/ideapad 320R-15IKB/ideapad 320E-15IKB/
ideapad 320-15IKB Touch, there is following type of LCD.

- “15.6-in. HD LED”

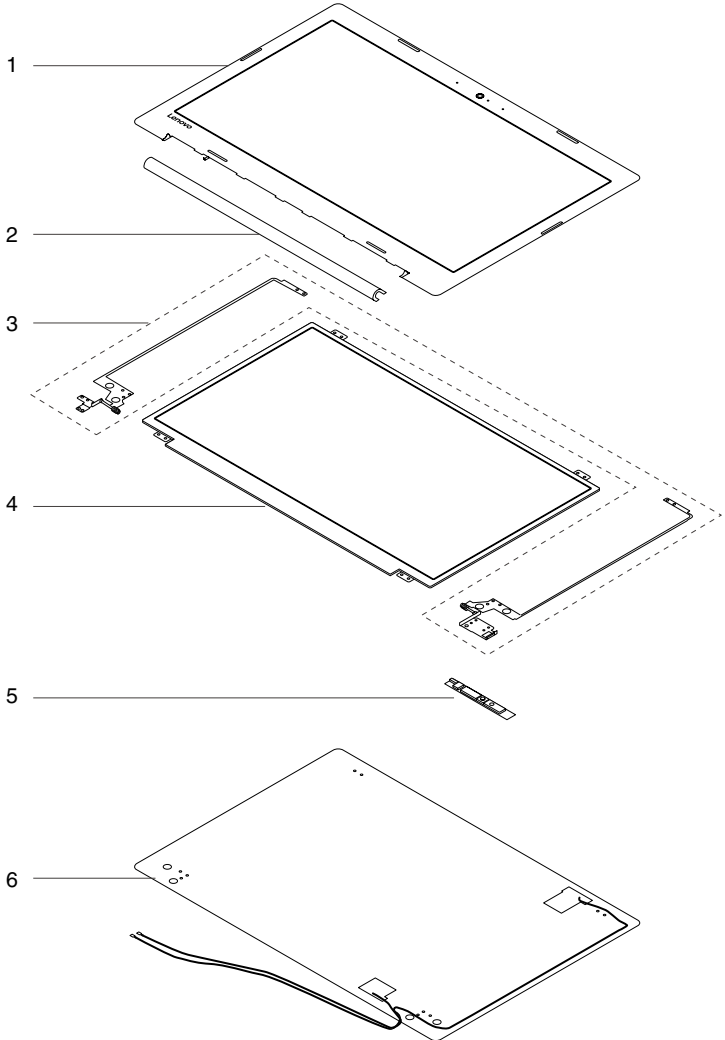

Lenovo ideapad 320-15ISK/ideapad 320H-15ISK/ideapad 320L-15ISK/ideapad 320R-15ISK/ideapad 320E-15ISK/ideapad 320-15IKB/ideapad 320H-15IKB/ideapad 320L-15IKB/ideapad 320R-15IKB/ideapad 320E-15IKB/ideapad 320-15IKB Touch

Table 5. Parts list—LCD FRUs

No.	FRU	FRU no.	CRU ID.
1	LCDBEZELL80XLTEX15TBKWCAMMYMAGNET	5B30N86341	N
2	HINGECAP15TL80XL BW PT	5CB0N86453	
2	HINGECAP15TL80XL PG PT	5CB0N86380	
2	HINGECAP15TL80XL OB PT	5CB0N86462	
2	HINGECAP15TL80XL PPL PT	5CB0N86459	
2	HINGECAP15TL80XL DBU PT	5CB0N86474	
2	HINGECAP15TL80XL CR PT	5CB0N86566	
3	HINGE LR 15T L80XL	5H50N86361	
4	15" Panel, 15.6" HD TN Slim AG (3.2mm), AU B156XTN07.1 3A HDT AG S NB	5D10H52713	
4	15" Panel, 15.6" HD TN Slim AG (3.2mm), INX N156BGA-EA2 HDT AG S NB	5D10K81086	
4	15" Panel, 15.6" HD TN Slim AG (3.2mm), BO NT156WHM-N42 V8 HDT AG S NB	5D10K81097	
4	15" Panel, 15.6" FHD TN Slim AG (3.2mm), AU B156HTN03.8 0C FHDT AG S NB	5D10L08702	
4	15" Panel, 15.6" FHD TN Slim AG (3.2mm), IN N156HGA-EAB FHDT AG S NB	5D10K93435	
4	15" Panel, 15.6" FHD TN Slim AG (3.2mm), BO NT156FHM-N41 FHDT AG S NB	5D10K93434	
4	On Cell panel, 15.6" On-cell HD TN GL Slim Touch LCD, AU B156XTK01.0 5A HDT G S NB(T)	5D10M41896	
4	On Cell panel, 15.6" On-cell HD TN GL Slim Touch LCD, IN N156BGN-E41 HDT G S NB(T)	5D10K81098	
5	CAMERA L80XK 0.3M W1 MIC	5C20N82280	
5	CAMERA L80XK HD W1 MIC	5C20N82351	
5	Camera, HD W /Single MIC, BIS BNCR1NKSK HD NB camera	SC20M52085	
5	Camera, HD W /Single MIC, CCY CNFGH41 HD NB camera	SC20M52089	
5	Camera, HD W /Single MIC, LTN 6SF111N2 HD NB camera	SC20M52114	
5	Camera, HD W /Single MIC, AVC HAA-8F4A03 HD NB camera	SC20M52087	
5	Camera, 0.3M W/ Single MIC, BIS BNCRVTKTL 0.3M NB camera	SC20M52088	
5	Camera, 0.3M W/ Single MIC, CCY CNFG020 0.3M NB camera	SC20M52082	
5	Camera, 0.3M W/ Single MIC, AWA AM-6SF5A02 0.3M NB camera	SC20M52079	
5	Camera, 0.3M W/ Single MIC, AVC HAA-93C501 0.3M NB camera	SC20M52080	
6	LCDCOVERL80XL15T BW PTANTE EDP	5CB0N86561	
6	LCDCOVERL80XL15T PG PTANTE EDP	5CB0N86313	
6	LCDCOVERL80XL15T OB PTANTE EDP	5CB0N86327	
6	LCDCOVERL80XL15T PPL PTANTE EDP	5CB0N86349	
6	LCDCOVERL80XL15T DBU PTANTE EDP	5CB0N86413	
6	LCDCOVERL80XL15T CR PTANTE EDP	5CB0N86358	

Miscellaneous parts

Table 6. Parts list—Miscellaneous parts

FRU	FRU no.	CRU ID.
System miscellaneous parts:		
• (a) ODD BRACKET L80SL	5B40L35764	N
• (b) ODD BEZEL L80XL TEX WH	5B30N86406	
• (b) ODD BEZEL L80XL TEX CG	5B30N86570	
• (b) ODD BEZEL L80XL PT LL	5B30N86513	
• (b) ODD BEZEL L80XL PT IB	5B30N86319	
• (b) ODD BEZEL L80XL PT LCR	5B30N86335	
• (c) HDD BRACKET L80XK	5B40N82219	
Note: Italicized letters in parentheses are references to the exploded view in "Overall" on page 65.		

AC adapters

Table 7. Parts list—2-pin AC adapters

FRU	P/N	CRU ID.
Adapter, 45W(New) wall mount with round plug (Low cost 45w Adaptor), Delta ADP-45DW A 20V2.25A COO	SA10M42800	*
Adapter, 45W(New) wall mount with round plug (Low cost 45w Adaptor), Delta ADP-45DW J 20V2.25A COO	SA10M42721	
Adapter, 45W(New) wall mount with round plug (Low cost 45w Adaptor), Delta ADP-45DW B 20V2.25A COO	SA10M42785	
Adapter, 45W(New) wall mount with round plug (Low cost 45w Adaptor), Delta ADP-45DW D 20V2.25A COO	SA10M42696	
Adapter, 45W(New) wall mount with round plug (Low cost 45w Adaptor), Delta ADP-45DW H 20V2.25A COO	SA10M42699	
Adapter, 45W(New) wall mount with round plug (Low cost 45w Adaptor), Delta ADP-45DW G 20V2.25A COO	SA10M42774	
Adapter, 45W(New) wall mount with round plug (Low cost 45w Adaptor), Delta ADP-45DW E 20V2.25A COO	SA10M42748	
Adapter, 45W(New) wall mount with round plug (Low cost 45w Adaptor), Delta ADP-45DW C 20V2.25A COO	SA10M42700	
Adapter, 45W(New) wall mount with round plug (Low cost 45w Adaptor), Delta ADP-45DW K 20V2.25A COO	SA10M42804	
Adapter, 45W(New) wall mount with round plug (Low cost 45w Adaptor), Liteon PA-1450-55LN 20V2.25A COO	SA10M42711	
Adapter, 45W(New) wall mount with round plug (Low cost 45w Adaptor), Liteon PA-1450-55LG 20V2.25A COO	SA10M42709	
Adapter, 45W(New) wall mount with round plug (Low cost 45w Adaptor), Liteon PA-1450-55LL 20V2.25A COO	SA10M42742	
Adapter, 45W(New) wall mount with round plug (Low cost 45w Adaptor), Liteon PA-1450-55LK 20V2.25A COO	SA10M42530	
Adapter, 45W(New) wall mount with round plug (Low cost 45w Adaptor), Liteon PA-1450-55LI 20V2.25A COO	SA10M42734	
Adapter, 45W(New) wall mount with round plug (Low cost 45w Adaptor), Liteon PA-1450-55LR 20V2.25A COO	SA10M42701	

Lenovo ideapad 320-15ISK/ideapad 320H-15ISK/ideapad 320L-15ISK/ideapad 320R-15ISK/ideapad 320E-15ISK/ideapad 320-15IKB/ideapad 320H-15IKB/ideapad 320L-15IKB/ideapad 320R-15IKB/ideapad 320E-15IKB/ideapad 320-15IKB Touch

Table 7. Parts list—2-pin AC adapters (continued)

FRU	P/N	CRU ID.
Adapter, 45W(New) wall mount with round plug (Low cost 45w Adaptor), Liteon PA-1450-55LS 20V2.25A COO	SA10M42736	
Adapter, 45W(New) wall mount with round plug (Low cost 45w Adaptor), Liteon PA-1450-55LU 20V2.25A COO	SA10M42743	
Adapter, 45W(New) wall mount with round plug (Low cost 45w Adaptor), Liteon PA-1450-55LZ 20V2.25A COO	SA10M42752	
Adapter, 45W(New) wall mount with round plug (Low cost 45w Adaptor), Chicony ADL45WCA 20V2.25A COO	SA10M42726	
Adapter, 45W(New) wall mount with round plug (Low cost 45w Adaptor), Chicony ADL45WCB 20V2.25A COO	SA10M42737	
Adapter, 45W(New) wall mount with round plug (Low cost 45w Adaptor), Chicony ADL45WCC 20V2.25A COO	SA10M42697	
Adapter, 45W(New) wall mount with round plug (Low cost 45w Adaptor), Chicony ADL45WCD 20V2.25A COO	SA10M42790	
Adapter, 45W(New) wall mount with round plug (Low cost 45w Adaptor), Chicony ADL45WCK 20V2.25A COO	SA10M42768	
Adapter, 45W(New) wall mount with round plug (Low cost 45w Adaptor), Chicony ADL45WCE 20V2.25A COO	SA10M42706	
Adapter, 45W(New) wall mount with round plug (Low cost 45w Adaptor), Chicony ADL45WCF 20V2.25A COO	SA10M42746	
Adapter, 45W(New) wall mount with round plug (Low cost 45w Adaptor), Chicony ADL45WCG 20V2.25A COO	SA10M42792	
Adapter, 45W(New) wall mount with round plug (Low cost 45w Adaptor), Chicony ADL45WCH 20V2.25A COO	SA10M42786	
Adapter, 65W(New) wall mount with round plug (Low cost 65W Adaptor), Delta ADLX65CDGKC2A 20V3.25A COO	SA10M42764	*
Adapter, 65W(New) wall mount with round plug (Low cost 65W Adaptor), Delta ADLX65CDGG2A 20V3.25A COO	SA10M42758	
Adapter, 65W(New) wall mount with round plug (Low cost 65W Adaptor), Delta ADLX65CDGU2A 20V3.25A COO	SA10M42765	
Adapter, 65W(New) wall mount with round plug (Low cost 65W Adaptor), Delta ADLX65CDGK2A 20V3.25A COO	SA10M42745	
Adapter, 65W(New) wall mount with round plug (Low cost 65W Adaptor), Delta ADLX65CDGI2A 20V3.25A COO	SA10M42796	
Adapter, 65W(New) wall mount with round plug (Low cost 65W Adaptor), Delta ADLX65CDGR2A 20V3.25A COO	SA10M42775	
Adapter, 65W(New) wall mount with round plug (Low cost 65W Adaptor), Delta ADLX65CDGA2A 20V3.25A COO	SA10M42718	
Adapter, 65W(New) wall mount with round plug (Low cost 65W Adaptor), Delta ADLX65CDGE2A 20V3.25A COO	SA10M42794	
Adapter, 65W(New) wall mount with round plug (Low cost 65W Adaptor), Delta ADLX65CDGB2A 20V3.25A COO	SA10M42769	
Adapter, 65W(New) wall mount with round plug (Low cost 65W Adaptor), Liteon ADLX65CLGC2A 20V3.25A COO	SA10M42791	
Adapter, 65W(New) wall mount with round plug (Low cost 65W Adaptor), Liteon ADLX65CLGG2A 20V3.25A COO	SA10M42714	
Adapter, 65W(New) wall mount with round plug (Low cost 65W Adaptor), Liteon ADLX65CLGU2A 20V3.25A COO	SA10M42725	
Adapter, 65W(New) wall mount with round plug (Low cost 65W Adaptor), Liteon ADLX65CLGK2A 20V3.25A COO	SA10M42531	

Table 7. Parts list—2-pin AC adapters (continued)

FRU	P/N	CRU ID.
Adapter, 65W(New) wall mount with round plug (Low cost 65W Adaptor), Liteon ADLX65CLGI2A 20V3.25A COO	SA10M42753	*
Adapter, 65W(New) wall mount with round plug (Low cost 65W Adaptor), Liteon ADLX65CLGR2A 20V3.25A COO	SA10M42738	
Adapter, 65W(New) wall mount with round plug (Low cost 65W Adaptor), Liteon ADLX65CLGA2A 20V3.25A COO	SA10M42793	
Adapter, 65W(New) wall mount with round plug (Low cost 65W Adaptor), Liteon ADLX65CLGE2A 20V3.25A COO	SA10M42740	
Adapter, 65W(New) wall mount with round plug (Low cost 65W Adaptor), Liteon ADLX65CLGB2A 20V3.25A COO	SA10M42817	
Adapter, 65W(New) wall mount with round plug (Low cost 65W Adaptor), Chicony ADLX65CCGC2A 20V3.25A COO	SA10M42805	
Adapter, 65W(New) wall mount with round plug (Low cost 65W Adaptor), Chicony ADLX65CCGG2A 20V3.25A COO	SA10M42815	
Adapter, 65W(New) wall mount with round plug (Low cost 65W Adaptor), Chicony ADLX65CCGU2A 20V3.25A COO	SA10M42762	
Adapter, 65W(New) wall mount with round plug (Low cost 65W Adaptor), Chicony ADLX65CCGK2A 20V3.25A COO	SA10M42735	
Adapter, 65W(New) wall mount with round plug (Low cost 65W Adaptor), Chicony ADLX65CCGI2A 20V3.25A COO	SA10M42751	
Adapter, 65W(New) wall mount with round plug (Low cost 65W Adaptor), Chicony ADLX65CCGR2A 20V3.25A COO	SA10M42704	
Adapter, 65W(New) wall mount with round plug (Low cost 65W Adaptor), Chicony ADLX65CCGA2A 20V3.25A COO	SA10M42766	
Adapter, 65W(New) wall mount with round plug (Low cost 65W Adaptor), Chicony ADLX65CCGE2A 20V3.25A COO	SA10M42760	
Adapter, 65W(New) wall mount with round plug (Low cost 65W Adaptor), Chicony ADLX65CCGB2A 20V3.25A COO	SA10M42707	

Screws

Table 8. Parts list—screws

FRU	P/N	CRU ID.
SCREWL80XKMM2.5D7.0LK4.5D0.8T ZKNL	5S10N82242	N
SCREWL80XKMM2.5D7.0LK4.5D0.8T NINL	5S10N82325	N
SCREW L MM1.98D3LK4.5DNINL0.4T	5S10K25435	N
AILZA Screw M M 2 2.0D 2L K 7D	90203987	N
SCREW L80T6 MM 2.5D 2.5L K 8.0D NI	5S10L45749	N
Screw L Y700-15ACZ Hinge base	5S10K26861	N
ACLU1ScrewD-C/D-KB/ODD-D-MB-KB/FAN	90205118	N

Notices

Lenovo may not offer the products, services, or features discussed in this document in all countries. Consult your local Lenovo representative for information on the products and services currently available in your area. Any reference to a Lenovo product, program, or service is not intended to state or imply that only that Lenovo product, program, or service may be used. Any functionally equivalent product, program, or service that does not infringe any Lenovo intellectual property right may be used instead. However, it is the user's responsibility to evaluate and verify the operation of any other product, program, or service.

Lenovo may have patents or pending patent applications covering subject matter described in this document. The furnishing of this document does not give you any license to these patents.

LENOVO GROUP LTD. PROVIDES THIS PUBLICATION "AS IS" WITHOUT WARRANTY OF ANY KIND, EITHER EXPRESS OR IMPLIED, INCLUDING, BUT NOT LIMITED TO, THE IMPLIED WARRANTIES OF NON-INFRINGEMENT, MERCHANTABILITY OR FITNESS FOR A PARTICULAR PURPOSE. Some jurisdictions do not allow disclaimer of express or implied warranties in certain transactions, therefore, this statement may not apply to you.

This information could include technical inaccuracies or typographical errors. Changes are periodically made to the information herein; these changes will be incorporated in new editions of the publication. Lenovo may make improvements and/or changes in the product(s) and/or the program(s) described in this publication at any time without notice.

The products described in this document are not intended for use in implantation or other life support applications where malfunction may result in injury or death to persons. The information contained in this document does not affect or change Lenovo product specifications or warranties. Nothing in this document shall operate as an express or implied license or indemnity under the intellectual property rights of Lenovo or third parties. All information contained in this document was obtained in specific environments and is presented as an illustration. The result obtained in other operating environments may vary.

Lenovo may use or distribute any of the information you supply in any way it believes appropriate without incurring any obligation to you.

Any references in this publication to non-Lenovo Web sites are provided for convenience only and do not in any manner serve as an endorsement of those Web sites. The materials at those Web sites are not part of the materials for this Lenovo product, and use of those Web sites is at your own risk.

Any performance data contained herein was determined in a controlled environment. Therefore, the result obtained in other operating environments may vary significantly. Some measurements may have been made on development-level systems and there is no guarantee that these measurements will be the same on generally available systems. Furthermore, some measurements may have been estimated through extrapolation. Actual results may vary. Users of this document should verify the applicable data for their specific environment.

Trademarks

The following terms are trademarks or registered trademarks of Lenovo in the United States, other countries, or both.

Lenovo
OneKey

Microsoft and Windows are trademarks of Microsoft Corporation in the United States, other countries, or both.

Other company, products, or service names may be trademarks or service marks of others.