

lenovo

Lenovo Erazer X310 Hardware Maintenance Manual

The image features the Lenovo logo in white, italicized lowercase letters on a black background. To the right of the logo, the words "FOR", "THOSE", "WHO", and "DO." are stacked vertically in white, uppercase letters, each contained within a red rectangular box. A small "TM" trademark symbol is positioned to the right of the "DO." box.

lenovo® **FOR**
THOSE
WHO DO.™

Machine Types: 90AV [X310 ES];90AU [X310 Non-ES]



Lenovo Erazer X310
Hardware Maintenance Manual

Machine Types: 90AV [X310 ES];90AU [X310 Non-ES]

First Edition (Sept. 2014)15th

© Copyright Lenovo 2014.

LIMITED AND RESTRICTED RIGHTS NOTICE: If data or software are delivered pursuant a General Services Administration "GSA" contract, use, reproduction, or disclosure is subject to restrictions set forth in Contract No. GS-35F-05925

Contents

Chapter 1. About this manual	1	Additional Service Information	19
Important Safety Information	1	POST error codes	20
Chapter 2. Safety information	3	Undetermined problems	20
General safety	3	Chapter 7. Locations	23
Electrical safety	3	Identifying internal components	23
Safety inspection guide	5	Identifying parts on the system board.	23
Handling electrostatic discharge-sensitive devices	5	Chapter 8. Replacing hardware	25
Grounding requirements	6	General information.	25
Safety notices	6	Replacing the keyboard and mouse	26
Chapter 3. General information	9	Removing the computer cover	26
Specifications	9	Removing the front bezel	27
Chapter 4. General Checkout	11	Replacing a memory module	28
Chapter 5. Using the Setup Utility.	13	Replacing a hard disk drive.	28
Starting the Lenovo BIOS Setup Utility program	13	Replacing an optical drive	29
Viewing and changing settings	13	Replacing a graphics card	30
Using passwords.	13	Replacing the Power supply	31
Enabling or disabling a device	15	Replacing the microprocessor fan	32
Selecting a startup device	16	Replacing the heat-sink	33
Exiting the Lenovo BIOS Setup Utility program	17	Replacing the CPU	34
Chapter 6. Symptom-to-FRU Index	19	Replacing the Wi-Fi card.	36
Hard disk drive boot error	19	Replacing the motherboard.	37
Power Supply Problems	19	FRU lists	38
		Chapter 9. General information	47
		Additional Service Information	47

Chapter 1. About this manual

This manual contains service and reference information for Lenovo Erazer X310 computers listed on the cover. It is intended only for trained servicers who are familiar with Lenovo computer products.

Before servicing a Lenovo product, be sure to read the Safety Information.

The description of the TV card in this manual is only used for the machines which have the TV card. It is invalid for those machines which do not have TV card.

Important Safety Information

Be sure to read all caution and danger statements in this book before performing any of the instructions.

Veillez lire toutes les consignes de type DANGER et ATTENTION du présent document avant d'exécuter les instructions.

Lesen Sie unbedingt alle Hinweise vom Typ "ACHTUNG" oder "VORSICHT" in dieser Dokumentation, bevor Sie irgendwelche Vorgänge durchführen

Leggere le istruzioni introdotte da ATTENZIONE e PERICOLO presenti nel manuale prima di eseguire una qualsiasi delle istruzioni

Certifique-se de ler todas as instruções de cuidado e perigo neste manual antes de executar qualquer uma das instruções

Es importante que lea todas las declaraciones de precaución y de peligro de este manual antes de seguir las instrucciones.

执行任何说明之前，请确保已阅读本书中的所有警告和危险声明。

執行任何指示前，請確實閱讀本書中的所有警告及危險聲明。

Chapter 2. Safety information

This chapter contains the safety information that you need to be familiar with before servicing a computer.

General safety

Follow these rules to ensure general safety:

- Observe good housekeeping in the area of the machines during and after maintenance.
- When lifting any heavy object:
 1. Ensure you can stand safely without slipping.
 2. Distribute the weight of the object equally between your feet.
 3. Use a slow lifting force. Never move suddenly or twist when you attempt to lift.
 4. Lift by standing or by pushing up with your leg muscles; this action removes the strain from the muscles in your back.
Do not attempt to lift any objects that weigh more than 16 kg (35 lb) or objects that you think are too heavy for you.
- Do not perform any action that causes hazards to the customer, or that makes the equipment unsafe.
- Before you start the machine, ensure that other service representatives and the customer's personnel are not in a hazardous position.
- Place removed covers and other parts in a safe place, away from all personnel, while you are servicing the machine.
- Keep your tool case away from walk areas so that other people will not trip over it.
- Do not wear loose clothing that can be trapped in the moving parts of a machine. Ensure that your sleeves are fastened or rolled up above your elbows. If your hair is long, fasten it.
- Insert the ends of your necktie or scarf inside clothing or fasten it with a nonconductive clip, approximately 8 centimeters (3 inches) from the end.
- Do not wear jewelry, chains, metal-frame eyeglasses, or metal fasteners for your clothing.
Remember: Metal objects are good electrical conductors.
- Wear safety glasses when you are: hammering, drilling soldering, cutting wire, attaching springs, using solvents, or working in any other conditions that might be hazardous to your eyes.
- After service, reinstall all safety shields, guards, labels, and ground wires. Replace any safety device that is worn or defective.
- Reinstall all covers correctly before returning the machine to the customer.

Electrical safety



CAUTION:

Electrical current from power, telephone, and communication cables can be hazardous. To avoid personal injury or equipment damage, disconnect the attached power cords, telecommunication systems, networks, and modems before you open the computer covers, unless instructed otherwise in the installation and configuration procedures.

Observe the following rules when working on electrical equipment.

Important: Use only approved tools and test equipment. Some hand tools have handles covered with a soft material that does not insulate you when working with live electrical currents. Many customers have, near their equipment, rubber floor mats that contain small conductive fibers to decrease electrostatic discharges. Do not use this type of mat to protect yourself from electrical shock.

- Find the room emergency power-off (EPO) switch, disconnecting switch, or electrical outlet. If an electrical accident occurs, you can then operate the switch or unplug the power cord quickly.
- Do not work alone under hazardous conditions or near equipment that has hazardous voltages.
- Disconnect all power before:
 - Performing a mechanical inspection
 - Working near power supplies
 - Removing or installing Field Replaceable Units (FRUs)
- Before you start to work on the machine, unplug the power cord. If you cannot unplug it, ask the customer to power-off the wall box that supplies power to the machine and to lock the wall box in the off position.
- If you need to work on a machine that has exposed electrical circuits, observe the following precautions:
 - Ensure that another person, familiar with the power-off controls, is near you.
Remember: Another person must be there to switch off the power, if necessary.
 - Use only one hand when working with powered-on electrical equipment; keep the other hand in your pocket or behind your back.
Remember: There must be a complete circuit to cause electrical shock. By observing the above rule, you may prevent a current from passing through your body.
 - When using a tester, set the controls correctly and use the approved probe leads and accessories for that tester.
 - Stand on suitable rubber mats (obtained locally, if necessary) to insulate you from grounds such as metal floor strips and machine frames.

Observe the special safety precautions when you work with very high voltages; these instructions are in the safety sections of maintenance information. Use extreme care when measuring high voltages.

- Regularly inspect and maintain your electrical hand tools for safe operational condition.
- Do not use worn or broken tools and testers.
- *Never assume* that power has been disconnected from a circuit. First, *check* that it has been powered-off.
- Always look carefully for possible hazards in your work area. Examples of these hazards are moist floors, nongrounded power extension cables, power surges, and missing safety grounds.
- Do not touch live electrical circuits with the reflective surface of a plastic dental mirror. The surface is conductive; such touching can cause personal injury and machine damage.
- Do not service the following parts with the power on when they are removed from their normal operating places in a machine:
 - Power supply units
 - Pumps
 - Blowers and fans
 - Motor generatorsand similar units. (This practice ensures correct grounding of the units.)
- If an electrical accident occurs:
 - Use caution; do not become a victim yourself.
 - Switch off power.

- Send another person to get medical aid.

Safety inspection guide

The intent of this inspection guide is to assist you in identifying potentially unsafe conditions on these products. Each machine, as it was designed and built, had required safety items installed to protect users and service personnel from injury. This guide addresses only those items. However, good judgment should be used to identify potential safety hazards due to attachment of features or options not covered by this inspection guide.

If any unsafe conditions are present, you must determine how serious the apparent hazard could be and whether you can continue without first correcting the problem.

Consider these conditions and the safety hazards they present:

- Electrical hazards, especially primary power (primary voltage on the frame can cause serious or fatal electrical shock).
- Explosive hazards, such as a damaged CRT face or bulging capacitor
- Mechanical hazards, such as loose or missing hardware

The guide consists of a series of steps presented in a checklist. Begin the checks with the power off, and the power cord disconnected.

Checklist:

1. Check exterior covers for damage (loose, broken, or sharp edges).
2. Power-off the computer. Disconnect the power cord.
3. Check the power cord for:
 - a. A third-wire ground connector in good condition. Use a meter to measure third-wire ground continuity for 0.1 ohm or less between the external ground pin and frame ground.
 - b. The power cord should be the appropriate type as specified in the parts listings.
 - c. Insulation must not be frayed or worn.
4. Remove the cover.
5. Check for any obvious alterations. Use good judgment as to the safety of any alterations.
6. Check inside the unit for any obvious unsafe conditions, such as metal filings, contamination, water or other liquids, or signs of fire or smoke damage.
7. Check for worn, frayed, or pinched cables.
8. Check that the power-supply cover fasteners (screws or rivets) have not been removed or tampered with.

Handling electrostatic discharge-sensitive devices

Any computer part containing transistors or integrated circuits (ICs) should be considered sensitive to electrostatic discharge (ESD). ESD damage can occur when there is a difference in charge between objects. Protect against ESD damage by equalizing the charge so that the machine, the part, the work mat, and the person handling the part are all at the same charge.

Notes:

1. Use product-specific ESD procedures when they exceed the requirements noted here.
2. Make sure that the ESD protective devices you use have been certified (ISO 9000) as fully effective.

When handling ESD-sensitive parts:

- Keep the parts in protective packages until they are inserted into the product.

- Avoid contact with other people while handling the part.
- Wear a grounded wrist strap against your skin to eliminate static on your body.
- Prevent the part from touching your clothing. Most clothing is insulative and retains a charge even when you are wearing a wrist strap.
- Use the black side of a grounded work mat to provide a static-free work surface. The mat is especially useful when handling ESD-sensitive devices.
- Select a grounding system, such as those listed below, to provide protection that meets the specific service requirement.

Note: The use of a grounding system is desirable but not required to protect against ESD damage.

- Attach the ESD ground clip to any frame ground, ground braid, or green-wire ground.
- Use an ESD common ground or reference point when working on a double-insulated or battery-operated system. You can use coax or connector-outside shells on these systems.
- Use the round ground-prong of the ac plug on ac-operated computers.

Grounding requirements

Electrical grounding of the computer is required for operator safety and correct system function. Proper grounding of the electrical outlet can be verified by a certified electrician.

Safety notices

The caution and danger safety notices in this section are provided in the the language of English.



DANGER

Electrical current from power, telephone and communication cables is hazardous.

To avoid a shock hazard:

- **Do not connect or disconnect any cables or perform installation, maintenance, or reconfiguration of this product during an electrical storm.**
- **Connect all power cords to a properly wired and grounded electrical outlet.**
- **Connect to properly wired outlets any equipment that will be attached to this product.**
- **When possible, use one hand only to connect or disconnect signal cables.**
- **Never turn on any equipment when there is evidence of fire, water, or structural damage.**
- **Disconnect the attached power cords, telecommunications systems, networks, and modems before you open the device covers, unless instructed otherwise in the installation and configuration procedures.**
- **Connect and disconnect cables as described in the following table when installing, moving, or opening covers on this product or attached devices.**

To Connect	To Disconnect
<ol style="list-style-type: none"> 1. Turn everything OFF. 2. First, attach all cables to devices. 3. Attach signal cables to connectors. 4. Attach power cords to outlet. 5. Turn device ON. 	<ol style="list-style-type: none"> 1. Turn everything OFF. 2. First, remove power cords from outlet. 3. Remove signal cables from connectors. 4. Remove all cables from devices.



CAUTION:

When replacing the lithium battery, use only Part Number 45C1566 or an equivalent type battery recommended by the manufacturer. If your system has a module containing a lithium battery, replace it only with the same module type made by the same manufacturer. The battery contains lithium and can explode if not properly used, handled, or disposed of.

Do not:

- Throw or immerse into water
- Heat to more than 100°C (212°F)
- Repair or disassemble

Dispose of the battery as required by local ordinances or regulations.



CAUTION:

When laser products (such as CD-ROMs, DVD-ROM drives, fiber optic devices, or transmitters) are installed, note the following:

- Do not remove the covers. Removing the covers of the laser product could result in exposure to hazardous laser radiation. There are no serviceable parts inside the device.
- Use of controls or adjustments or performance of procedures other than those specified herein might result in hazardous radiation exposure.





 **DANGER**

Some laser products contain an embedded Class 3A or Class 3B laser diode. Note the following:

Laser radiation when open. Do not stare into the beam, do not view directly with optical instruments, and avoid direct exposure to the beam.



		
≥18 kg(37 lbs)	≥32 kg(70.5 lbs)	≥55 kg(121.2 lbs)

CAUTION:
Use safe practices when lifting.



CAUTION:
The power control button on the device and the power switch on the power supply do not turn off the electrical current supplied to the device. The device also might have more than one power cord. To remove all electrical current from the device, ensure that all power cords are disconnected from the power source.

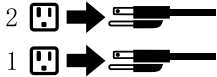

CAUTION:
Do not place any object weighing more than 82 kg (180 lbs.) on top of rack-mounted devices.



Chapter 3. General information

This chapter provides general information that applies to all machine types supported by this publication.

Specifications

This section lists the physical specifications for your computer.

This section lists the physical specifications for your computer.

Type Lenovo Erazer X310

This section lists the physical specifications.

Environment

Air temperature:

Operating: 10° to 35°C

Transit: -20° to 55°C

Humidity:

Operating: 35% to 80%

Transit: 20% to 90% (40°C)

Altitude: 86KPa to 106KPa

Electrical input:

Input voltage: 90V-264V(AC)

Input frequency: 47Hz-63Hz

Chapter 4. General Checkout

Attention: The drives in the computer you are servicing might have been rearranged or the drive startup sequence changed. Be extremely careful during write operations such as copying, saving, or formatting. Data or programs can be overwritten if you select an incorrect drive.

General error messages appear if a problem or conflict is found by an application program, the operating system, or both. For an explanation of these messages, refer to the information supplied with that software package.

Use the following procedure to help determine the cause of the problem:

1. Power-off the computer and all external devices.
2. Check all cables and power cords.
3. Set all display controls to the middle position.
4. Power-on all external devices.
5. Power-on the computer.
 - Look for displayed error codes
 - Look for readable instructions or a main menu on the display.

If you did not receive the correct response, proceed to step 6.

If you do receive the correct response, proceed to step 7.

6. Look at the following conditions and follow the instructions:
 - If the computer displays a POST error, go to “POST error codes”.
 - If the computer hangs and no error is displayed, continue at step 7.
7. If the test stops and you cannot continue, replace the last device tested.

Chapter 5. Using the Setup Utility

The Setup Utility program is used to view and change the configuration settings of your computer, regardless of which operating system you are using. However, the operating-system settings might override any similar settings in the Setup Utility program.

Starting the Lenovo BIOS Setup Utility program

To start the Lenovo BIOS Setup Utility program, do the following:

1. If your computer is already on when you start this procedure, shut down the operating system and turn off the computer.
2. Press and hold the **F1** key then turn on the computer. When the Lenovo BIOS Setup Utility program is displayed, release the **F1** key.

Note: If a Power-On Password or an Administrator Password has been set, the Setup Utility program menu is not displayed until you type your password. For more information, see “Using passwords.”

Viewing and changing settings

System configuration options are listed in the Lenovo BIOS Setup Utility program menu. To view or change settings, see “Starting the Setup Utility program.”

You must use the keyboard when using the Lenovo BIOS Setup Utility menu. The keys used to perform various tasks are displayed on the bottom of each screen.

Using passwords

You can use the Lenovo BIOS Setup Utility program to set passwords to prevent unauthorized persons from gaining access to your computer and data. See “Starting the Setup Utility program.” The following types of passwords are available:

- Set Administrator Password
- Set Power-On Password

You do not have to set any passwords to use your computer. However, if you decide to set passwords, read the following sections.

Password considerations

A password can be any combination of letters and numbers up to 16 character (a-z, and 0-9). For security reasons, it is a good idea to use a strong password that cannot be easily compromised. We suggest that passwords should follow these rules:

- Strong passwords contain 7-16 characters, combine letters and numbers.
- Do not use your name or your user name.
- Do not use a common word or a common name.
- Be significantly different from your previous password.

Attention: Administrator and Power-On passwords are not case sensitive

Administrator Password

Setting an Administrator Password deters unauthorized persons from changing configuration settings. You might want to set an Administrator Password if you are responsible for maintaining the settings of several computers.

After you set an Administrator Password, a password prompt is displayed every time you access the Lenovo BIOS Setup Utility program.

If both the Administrator and Power-On Password are set, you can type either password. However, you must use your Administrator Password to change any configuration settings.

Setting, changing, or deleting an Administrator password

To set an Administrator Password, do the following:

Note: A password can be any combination of letters and numbers up to 16 character (a-z, and 0-9). For more information, see “Password considerations” on page 13.

1. Start the Lenovo BIOS Setup Utility program (see “Starting the Lenovo BIOS Setup Utility program” on page 13).
2. From the **Security** menu, select **Set Administrator Password** and press the **Enter** key.
3. The password dialog box will be displayed. Type the password then press the **Enter** key.
4. Re-type the password to confirm, then press the **Enter** key. If you type the password correctly, the password will be installed.

To change an Administrator Password, do the following:

1. Start the Lenovo BIOS Setup Utility program (see “Starting the Lenovo BIOS Setup Utility program” on page 13).
2. From the **Security** menu, select **Set Administrator Password** and press the **Enter** key.
3. The password dialog box will be displayed. Type the current password then press **Enter** key.
4. Type the new password, then press **Enter** key. Re-type the password to confirm the new password, if you type the new password correctly, the new password will be installed. A Setup Notice will display that changes have been saved.

To delete a previously set Administrator Password, do the following :

1. From the **Security** menu, select **Set Administrator Password** and press the **Enter** key.
2. The password dialog box will be displayed. Type the current password and press the **Enter** key.
3. To delete an **Administrator Password**, **Enter** blank fields for each new password line item. A setup notice will display that changes have been saved.
4. Return to the Lenovo BIOS Setup Utility program menu and select the **Exit** option.
5. Select **Save changes and Exit** from the menu.

Power-On Password

When a Power-On Password is set, you cannot start the Lenovo BIOS Setup Utility program until a valid password is typed from the keyboard.

Setting, changing, or deleting a Power-On Password

Note: A password can be any combination of letters and numbers up to 16 character (a-z, and 0-9).

To set a Power-On Password, do the following:

1. Start the Lenovo BIOS Setup Utility program (See "Starting the Lenovo BIOS Setup Utility program" on page 13.)
2. From the **Security** menu, select **Set Power-On Password** and press the **Enter** key.
3. The password dialog box will be displayed. Type the password, and press the **Enter** key.
4. Re-type the password to confirm, if you type the password correctly, the password will be installed.

To change a Power-On Password, do the following:

1. Start the Lenovo BIOS Setup Utility program (See "Starting the Lenovo BIOS Setup Utility program" on page 13.)
2. From the **Security** menu, select **Set Power-On Password** and press the **Enter** key.
3. The password dialog box will be displayed. Type the current password then press the **Enter** key.
4. Type the new password, then press the **Enter** key. Re-type the password to confirm the new password, if you type the new password correctly, the new password will be installed. A setup notice will display that changes have been saved.

To delete a previously set Power-On Password, do the following :

1. From the **Security** menu, select **Set Power-On Password** and press the **Enter** key.
2. The password dialog box will be displayed. Type the current password and press the **Enter** key.
3. To delete the **Power-On Password**, **Enter** blank fields for each new password line item. A setup notice will display that changes have been saved.
4. Return to the Lenovo BIOS Setup Utility program menu and select the **Exit** option.
5. Select **Save changes and Exit** from the menu.

Enabling or disabling a device

The Devices options is used to enable or disable user access to the following devices:	
USB Functions	Select whether to enable or disable USB (Universal Serial Bus) functions. If the functions are disabled, no USB devices can be used.
ATA Drive Setup	Select IDE or ACHI mode. Device driver support is required for ACHI mode. Depending on how the hard disk image was installed, changing this setting may prevent the system from booting.
Onboard Audio Controller	Select whether to enable or disable the Onboard Audio Controller , when feature is set to Disabled all devices connected to the audio connectors (e.g. a headphone or a microphone) are disabled and can't be used.
Onboard Ethernet Controller or Boot Agent	Select whether to enable or disable Onboard Ethernet Controller , or select whether to enable or disable load onboard PXE (Preboot Execution Environment) , or SMC (Secure Managed Client) . This feature will allow the computer to boot from a server image.

To enable or disable a device, do the following:

1. Start the Setup Utility program (see "Starting the Setup Utility program" on page 13).
2. From the Setup Utility program menu, select **Devices**.
3. Select:

USB Setup press the **Enter** key, and then select **USB Functions**.

ATA Device Setup press the **Enter** key. Select **Configure SATA as**, press the **Enter** key and then select SATA mode.

Audio Setup press the **Enter** key, and then select **Onboard Audio Controller**.

Network Setup press the **Enter** key, then select **Onboard Ethernet Support** or **Boot Agent**.

4. Select **Disabled** or **Enabled** and press the **Enter** key.
5. Return to the Lenovo BIOS Setup Utility program menu and select the **Exit** option.
6. Select **Save changes and Exit** from the menu.

Note: If you do not want to save the settings, select **Discard changes and Exit** from the menu.

Selecting a startup device

If your computer does not boot from a device such as the CD/DVD-ROM drive disk or hard disk as expected, follow one of the procedures below.

Selecting a temporary startup device

Use this procedure to startup from any boot device.

Note: Not all CDs, DVDs or hard disk drives are bootable.

1. Turn off your computer.
2. Press and hold the **F12** key then turn on the computer. When the **Startup Device Menu** appears, release the **F12** key.

Note: If the **Startup Device Menu** does not display using these steps, repeatedly press and release the **F12** key rather than keeping it pressed when turning on the computer.

3. Use **↑** and **↓** arrows to select the desired startup device from the **Startup Device Menu** and press the **Enter** key to begin.

Note: Selecting a startup device from the **Startup Device Menu** does not permanently change the startup sequence.

Selecting or changing the startup device sequence

To view or permanently change the configured startup device sequence, do the following:

1. Start the Lenovo BIOS Setup Utility program (see “Starting the Lenovo BIOS Setup Utility program” on page 13).
2. From the Lenovo BIOS Setup Utility program main menu, select the **Startup** option.
3. Press the **Enter** key, and select the devices for the **Primary Boot Sequence**. Read the information displayed on the right side of the screen.
4. Use **-** and **←** arrows to select a device. Use the **<+>** or **<->** keys to move a device up or down. Use the **<x>** key to exclude the device from or include the device in the boot sequence.
5. Return to the Lenovo BIOS Setup Utility program menu and select the **Exit** option.
6. Select **Save changes and Exit** from the menu.

Notes:

- a. If you do not want to save the settings, select **Discard changes and Exit** from the menu.

- b. If you have changed these settings and want to return to the default settings, select **Load Optimal Defaults** from the menu.

Exiting the Lenovo BIOS Setup Utility program

After you finish viewing or changing settings, press the **Esc** key to return to the Lenovo BIOS Setup Utility program main menu. You might have to press the **Esc** key several times. Do one of the following:

- If you want to save the new settings, select **Save changes and Exit** from the menu. When the **Save & reset** window shows, select the **Yes** button, and then press the **Enter** key to exit the Lenovo BIOS Setup Utility program.
- If you do not want to save the settings, select **Discard changes and Exit** from the menu. When the **Reset Without Saving** window shows, select the **Yes** button, and then press the **Enter** key to exit the Setup Utility program.

Chapter 6. Symptom-to-FRU Index

The Symptom-to-FRU index lists error symptoms and possible causes. The most likely cause is listed first. Always begin with Chapter 4, “General Checkout,” on page 11. This index can also be used to help you decide which FRUs to have available when servicing a computer. If you are unable to correct the problem using this index, go to “Undetermined problems” on page 20.

Notes:

- If you have both an error message and an incorrect audio response, diagnose the error message first.
- If you cannot run the diagnostic tests or you get a diagnostic error code when running a test but did receive a POST error message, diagnose the POST error message first.
- If you did not receive any error message look for a description of your error symptoms in the first part of this index.

Hard disk drive boot error

A hard disk drive boot error can have the following causes.

Error	FRU/Action
The startup drive is not included in the boot sequence in configuration.	Check the configuration and ensure the startup drive is in the boot sequence.
No operating system installed on the boot drive.	Install an operating system on the boot drive.
The boot sector on the startup drive is corrupted.	The drive must be formatted. Do the following: <ol style="list-style-type: none">1. Attempt to back-up the data on the failing hard disk drive.2. Use the operating system to format the hard disk drive.
The drive is defective.	Replace the hard disk drive.

Power Supply Problems

Follow these procedures if you suspect there is a power supply problem.

Check/Verify	FRU/Action
Check that the following are properly installed: <ul style="list-style-type: none">• Power Cord• On/Off Switch connector• System Board Power Supply connectors• Microprocessor(s) connection	Reseat connectors
Check the power cord.	Power Cord
Check the power-on switch.	Power-on Switch

Additional Service Information

This chapter provides additional information that the service representative might find helpful.

Power management

Power management reduces the power consumption of certain components of the computer such as the system power supply, processor, hard disk drives, and some monitors.

Advanced configuration and power interface (ACPI) BIOS

As this computer has an ACPI BIOS system, the operating system is allowed to control the power management features of the computer and the settings for Advanced Power Management (APM) BIOS mode is ignored. Not all operating systems support ACPI BIOS mode.

Automatic Power-On features

The Automatic Power-On features within the Power Management menu allow you to enable and disable features that turn on the computer automatically.

- **Wake Up on Alarm:** You can specify a date and time at which the computer will be turned on automatically. This can be either a single event, a daily event or a weekly event.
- **Wake Up on LAN:** This feature allows LAN adapter card to wake the System.

POST error codes

Each time you turn the computer on, it performs a series of tests to check that the system is operating correctly and that certain options are set. This series of tests is called the *Power-On Self-Test*, or *POST*. POST does the following:

- Checks some basic system-board operations
- Checks that the memory is working correctly
- Starts video operations
- Verifies that the boot drive is working

POST Error Message	Description/Action
Keyboard error	Cannot initialize the keyboard. Make sure the keyboard is properly connected to the computer and that no keys are held pressed during POST. To purposely configure the computer without a keyboard, select Keyboardless operation in Startup option to Enabled . The BIOS then ignores the missing keyboard during POST.
Reboot and Select proper Boot device or Insert Boot Media in selected Boot device	The BIOS was unable to find a suitable boot device. Make sure the boot drive is properly connected to the computer. Make sure you have bootable media in the boot device.

Undetermined problems

1. Power-off the computer.
2. Remove or disconnect the following components (if connected or installed) one at a time.
 - a. External devices (modem, printer, or mouse)
 - b. Extended video memory
 - c. External Cache
 - d. External Cache RAM
 - e. Hard disk drive
 - f. Disk drive

3. Power-on the computer to re-test the system.
4. Repeat steps 1 through 3 until you find the failing device or component.

If all devices and components have been removed and the problem continues, replace the system board.

Chapter 7. Locations

This section provides illustrations to help locate the various connectors, controls and components of the computer.

Identifying internal components

The following illustration shows the components inside your computer.

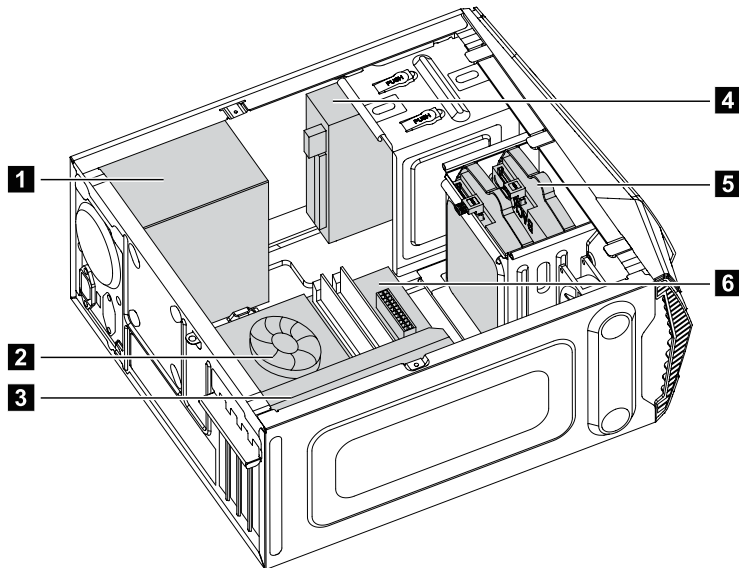

1 Power supply

2 Microprocessor fan and heatsink

3 Graphics card

4 Optical disk drive

5 Hard disk drive

6 System board

Identifying parts on the system board

The system board (also known as the “mainboard” or “motherboard”) is the main circuit board in your computer. It provides basic computer functions and supports a variety of devices that are factory-installed or that you can install later.

The following illustrations show the locations of the different parts on the system board.

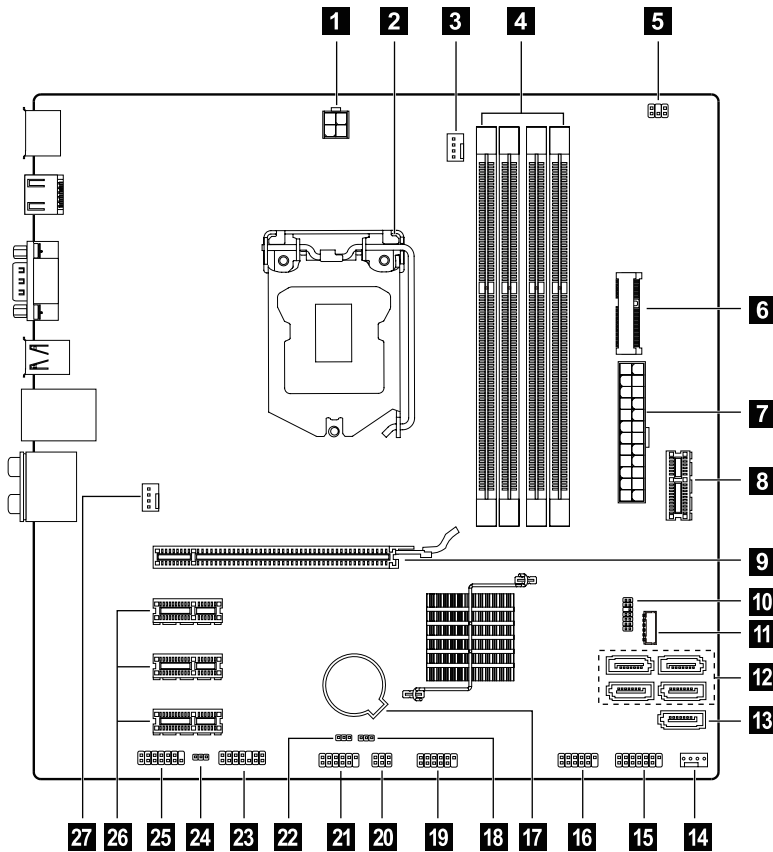

- | | |
|--|---|
| 1 12V power connector | 15 Front panel connector |
| 2 Microprocessor and heat sink | 16 Front USB 2.0 connector |
| 3 Microprocessor fan header | 17 Battery |
| 4 Memory slots (4) | 18 Clear CMOS jumper |
| 5 Thermal sensor header | 19 Front USB 3.0 connector |
| 6 Mini PCI-E slot | 20 Mode switch connector |
| 7 Power connector | 21 Serial (COM2)connector |
| 8 Front USB 3.0 slot | 22 ME disable jumper |
| 9 PCI express X 16 adapter slot | 23 LPC debug connector |
| 10 SPI debug connector | 24 Clear CMOS jumper |
| 11 Solid state disk power connector | 25 Front audio connector |
| 12 SATA connectors (4) | 26 PCI express X 1 adapter slots (3) |
| 13 eSATA connector | 27 System fan header |
| 14 Power fan header | |

Chapter 8. Replacing hardware

Attention: Do not remove the computer cover or attempt any repair before reading the “Important safety information” in the *Safety and Warranty Guide* that was included with your computer. To obtain copies of the Safety and Warranty Guide, go to the Support Web site at: <http://consumersupport.lenovo.com>

General information

Pre-disassembly instructions

Before proceeding with the disassembly procedure, make sure that you do the following:

1. Turn off the power to the system and all peripherals.
2. Unplug all power and signal cables from the computer.
3. Place the system on a flat, stable surface.

General information

Pre-disassembly instructions

Before proceeding with the disassembly procedure, make sure that you do the following:

1. Turn off the power to the system and all peripherals.
2. Unplug all power and signal cables from the computer.
3. Place the system on a flat, stable surface.

Replacing the keyboard and mouse

Note: Your keyboard will be connected to a USB connector at either front or at the rear of the computer.

To replace the keyboard:

- Step 1. Remove any media (disks, CDs, or memory cards) from the drives, shut down the computer, and turn off all attached devices.
- Step 2. Unplug all power cords from electrical outlets.
- Step 3. Locate the connector for the keyboard. Refer to “Front view of the chassis” and “Rear view of the chassis”.

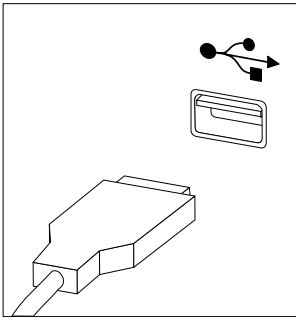

- Step 4. Disconnect the defective keyboard cable from the computer and connect the new keyboard cable to the same connector.
- Step 5. The mouse can be replaced using the same method.

Removing the computer cover

Attention:

- Turn off the computer and wait 3 to 5 minutes to let it cool down before removing the cover.
- For this procedure, it helps to lay the computer on a flat, stable surface.

To remove the computer cover:

- Step 1. Remove any media (disks, CDs, or memory cards) from the drives, shut down the computer, and turn off all attached devices.
- Step 2. Unplug all power cords from electrical outlets.
- Step 3. Disconnect all cables attached to the computer. This includes power cords, input/output (I/O) cables, and any other cables that are connected to the computer. Refer to “Locating connectors on the rear of the computer”.
- Step 4. Remove the two screws that secure the computer cover at the rear of the chassis.

Step 5. Slide the computer cover out to remove it.

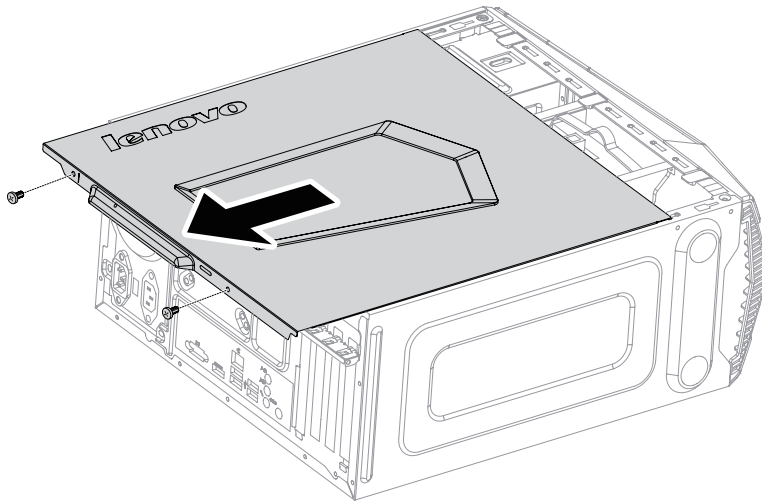

Removing the front bezel

Note: For this procedure, it helps to lay the computer flat.

To remove the front bezel:

- Step 1. Remove the computer cover. Refer to “Removing the computer cover”.
- Step 2. Remove the front bezel by releasing the three plastic tabs inside the chassis and pulling the bezel out as shown.

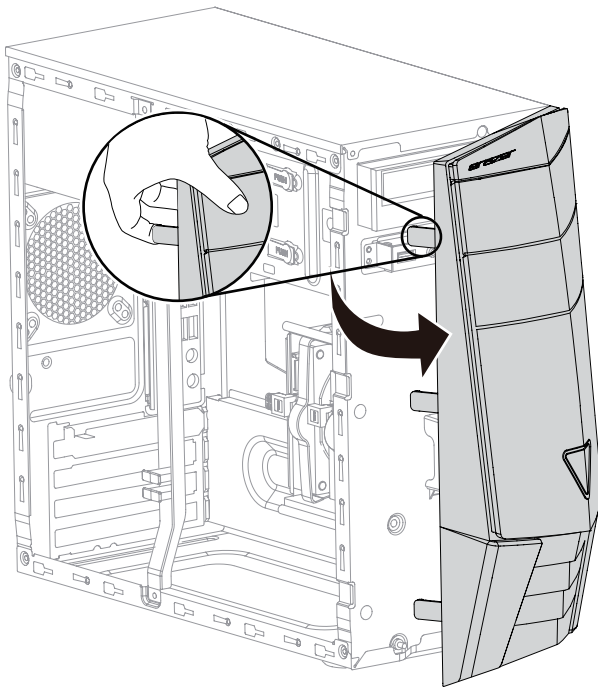

- Step 3. To reattach the bezel, align the plastic tabs on the bottom of the bezel with the corresponding holes in the chassis, and then snap it into position.

Replacing a memory module

Note: For this procedure, it helps to lay the computer flat.

To replace a memory module:

- Step 1. Remove the computer cover. Refer to “Removing the computer cover”.
- Step 2. Locate the memory module connectors. Refer to “Locating components”.
- Step 3. Remove the memory module to be replaced by opening the retaining clips as shown.

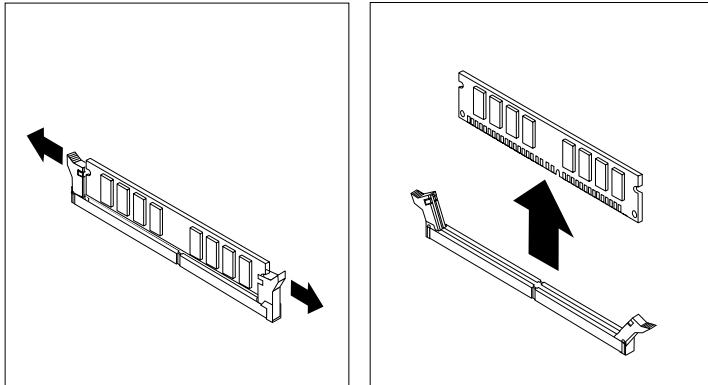

- Step 4. Position the new memory module over the memory connector. Make sure that the notch **1** on the memory module aligns correctly with the connector key **2** on the system board. Push the memory module straight down into the connector until the retaining clips close.

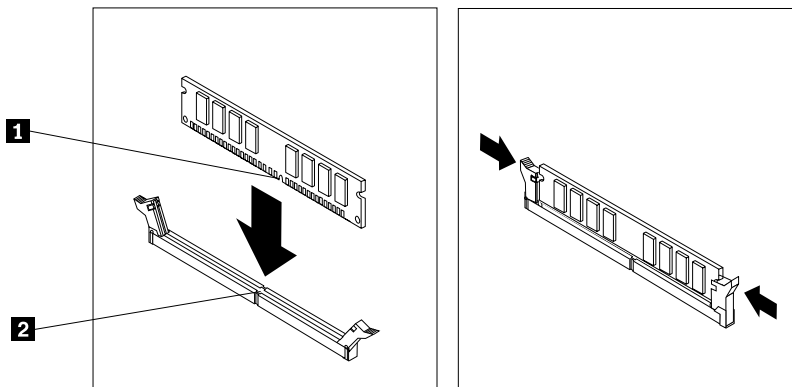

- Step 5. Reattach the computer cover.

Replacing a hard disk drive

Note: For this procedure, it helps to lay the computer flat.

To replace a hard disk drive:

- Step 1. Remove the computer cover. Refer to “Removing the computer cover”.
- Step 2. Disconnect the data and power cables from the hard disk drive. **1**

Step 3. Lift up the plastic handle and slide the hard disk drive out of the drive bay. **2**

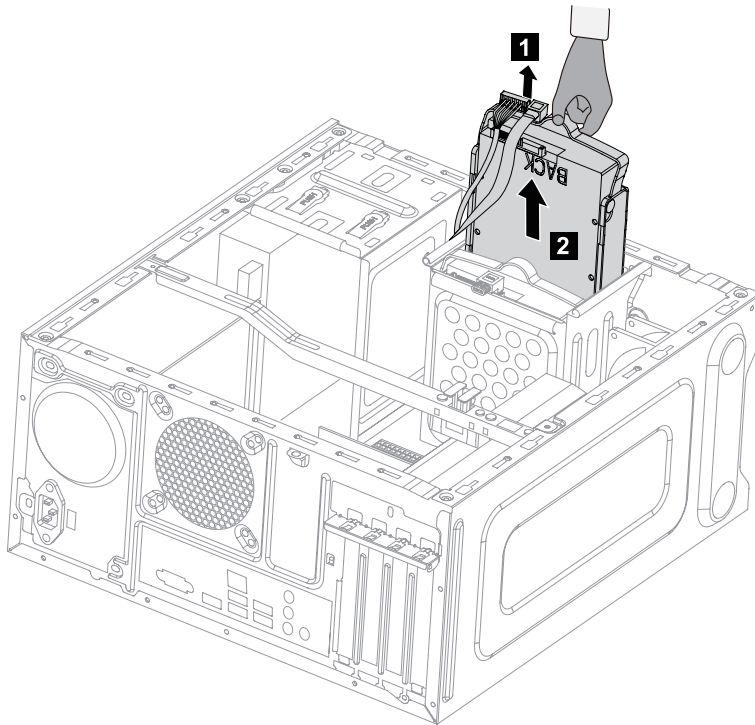

Step 4. Remove the hard disk drive from the plastic bracket as shown.

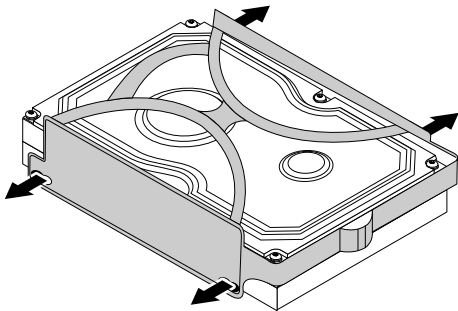

Step 5. Line up the new hard disk drive with the plastic bracket and snap it into position.

Step 6. Slide the new hard disk drive into the drive bay and slide the drive bay into place.

Step 7. Connect the power and signal cables to the new hard disk drive.

Step 8. Reattach the computer cover.

Replacing an optical drive

Note: For this procedure, it helps to lay the computer flat, stable surface.

To replace an optical drive:

Step 1. Remove the computer cover. Refer to “Removing the computer cover”.

Step 2. Remove the front bezel. Refer to “Removing the front bezel”.

Step 3. Disconnect the data and power cables from the rear of the optical drive. **1**

Step 4. Press the release button and push the optical drive straight out of the front of the chassis. **2 3**

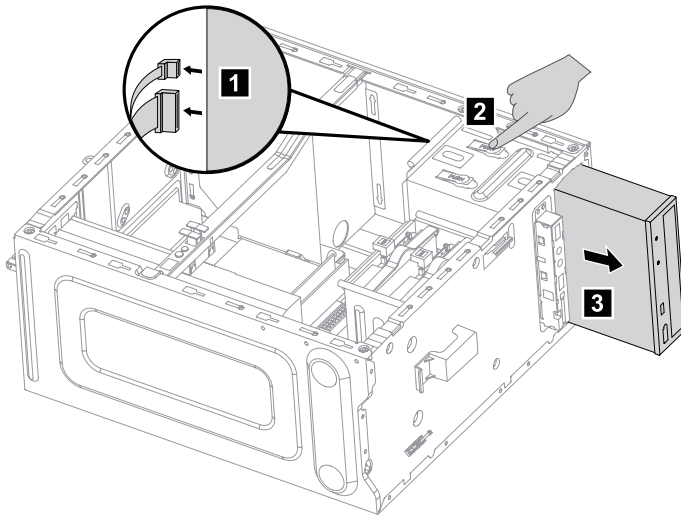

Step 5. Slide the new optical drive into the bay from the front until it snaps into position.

Step 6. Connect the data and power cables to the new disk drive.

Step 7. Reattach the front bezel and computer cover.

Replacing a graphics card

Note: For this procedure, it helps to lay the computer on a flat, stable surface.

To replace a graphics card:

Step 1. Remove the computer cover. Refer to “Removing the computer cover”.

Step 2. Remove the screw that secures the graphics card fixing bracket and lift the bracket up. **1**

Step 3. Remove the screw that secures the graphics latch to the chassis and open it. **2 3**

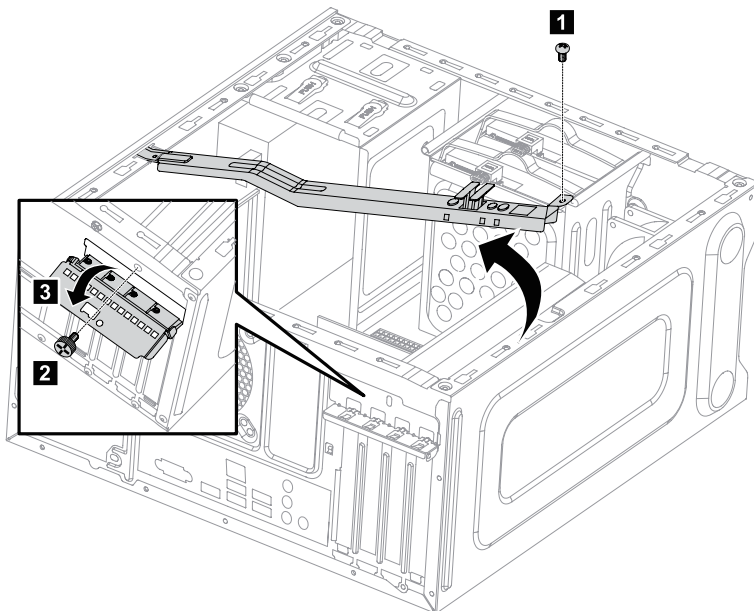

Step 4. Disconnect the power cables from the graphics card. **1**

Step 5. Push the pin to unlock the graphics card , and then lift up the graphics card to remove it. **2 3**

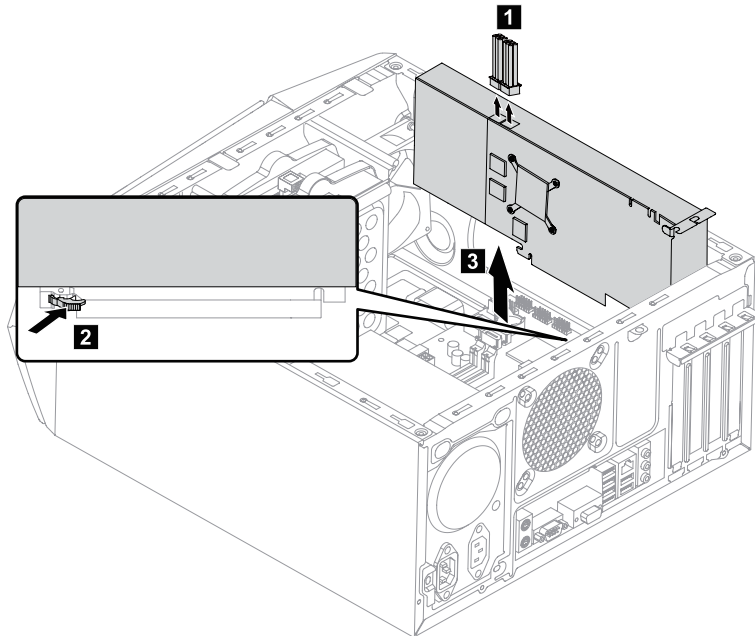

Step 6. To install the new graphics card:

- a. Attach the new graphics card to the same adapter connector.
- b. Connect the power cables to the new graphics card.
- c. Turn the graphics card latch to the closed position and secure it with the screw.

Step 7. Reattach the graphics card fixing bracket and computer cover.

Replacing the Power supply

Note: For this procedure, it helps to lay the computer flat.

To replace the Power supply:

- Step 1. Remove any media (disks, CDs, DVDs, or memory cards) from the drives, shut down the operating system, and turn off the computer and all attached devices.
- Step 2. Unplug all power cords from electrical outlets.
- Step 3. Disconnect all cables attached to the computer. This includes power cords, input/output (I/O) cables, and any other cables that are connected to the computer. Refer to “Left and right view” and “Rear view” for help with locating the various connectors.
- Step 4. Remove the computer cover. Refer to “Removing the computer cover”.
- Step 5. Disconnect the power cables from the connectors on motherboard. **1**
- Step 6. Remove the 4 screws that secure the Power supply to the chassis. **2**

Step 7. Slide then lift the Power supply out of chassis. **3 4**

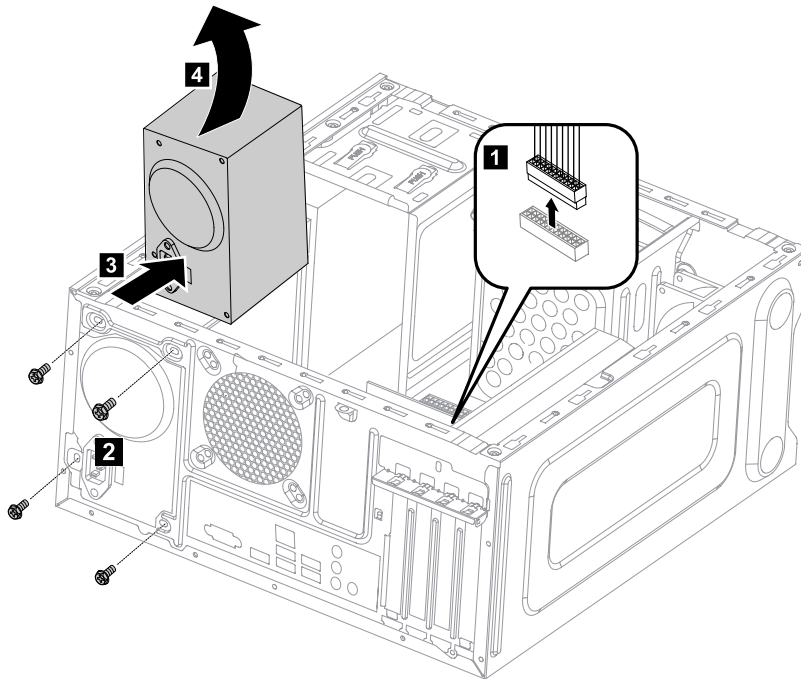

Step 8. Install the new power supply :

- a. Line up the holes on the new power supply with mounting holes on the rear of the chassis and secure it to the chassis with the 4 screws.
- b. Connect the power cables to the connectors on the motherboard.

Step 9. Reattach the computer cover.

Replacing the microprocessor fan

To replace the microprocessor fan:

- Step 1. Remove any media (disks, CDs, DVDs, or memory cards) from the drives, shut down the operating system, and turn off the computer and all attached devices.
- Step 2. Unplug all power cords from electrical outlets.
- Step 3. Disconnect all cables attached to the computer. This includes power cords, input/output (I/O) cables, and any other cables that are connected to the computer. Refer to “Left and right view” and “Rear view” for help with locating the various connectors.
- Step 4. Remove the computer cover. Refer to “Removing the computer cover”.
- Step 5. Disconnect the fan power cable from the connector on the motherboard.

Step 6. Remove the 4 screws that secure the microprocessor fan to the heat-sink and lift up the microprocessor fan to remove it.

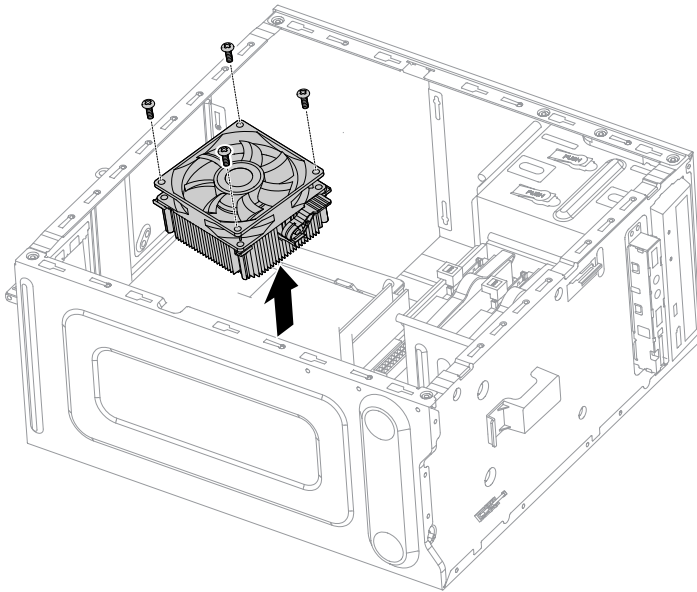

Step 7. To install the new microprocessor fan:

- a. Line up the new microprocessor fan with the heat-sink and secure it to the heat-sink with 4 screws.
- b. Connect the microprocessor fan power cable to the connector on the board.

Step 8. Reattach the computer cover.

Replacing the heat-sink

Note: For this procedure, it helps to lay the computer flat.

To replace the heat-sink:

- Step 1. Remove any media (disks, CDs, DVDs, or memory cards) from the drives, shut down the operating system, and turn off the computer and all attached devices.
- Step 2. Unplug all power cords from electrical outlets.
- Step 3. Disconnect all cables attached to the computer. This includes power cords, input/output (I/O) cables, and any other cables that are connected to the computer. Refer to “Left and right view” and “Rear view” for help with locating the various connectors.
- Step 4. Remove the computer cover. Refer to “Removing the computer cover”.
- Step 5. Remove the microprocessor fan. Refer to “Replacing the microprocessor fan”.
- Step 6. Remove the 4 screws that secure the heat-sink to the motherboard.

Step 7. Lift up the heat-sink to remove it.

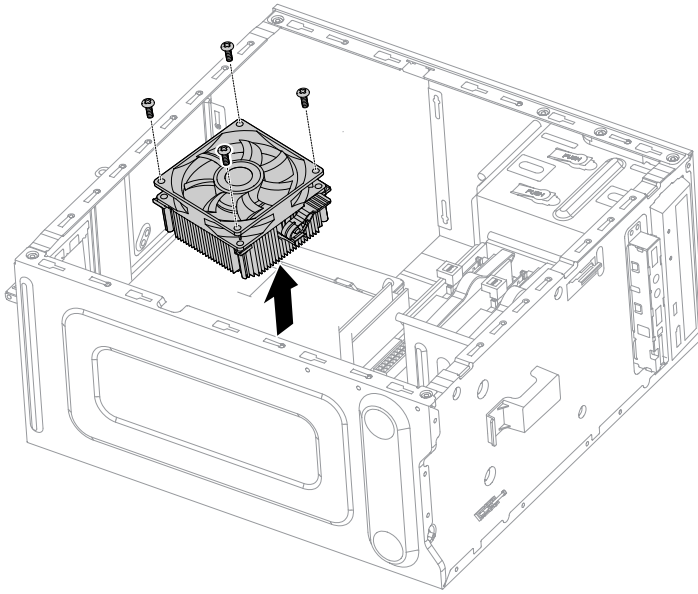

Step 8. Install the new heat-sink :

- a. Line up the screws on the new heat-sink with mounting holes on the motherboard and secure it with the 4 screws.
- b. Reattach the microprocessor fan to the heat-sink.
- c. Reconnect the microprocessor fan power cable to the connector on the motherboard.

Step 9. Reattach the computer cover.

Replacing the CPU

Note: For this procedure, it helps to lay the computer flat.

To replace the CPU:

- Step 1. Remove any media (disks, CDs, DVDs, or memory cards) from the drives, shut down the operating system, and turn off the computer and all attached devices.
- Step 2. Unplug all power cords from electrical outlets.
- Step 3. Disconnect all cables attached to the computer. This includes power cords, input/output (I/O) cables, and any other cables that are connected to the computer. Refer to “Left and right view” and “Rear view” for help with locating the various connectors.
- Step 4. Remove the computer cover. Refer to “Removing the computer cover”.
- Step 5. Remove the microprocessor fan. Refer to “Replacing the microprocessor fan”.
- Step 6. Remove the heat-sink. Refer to “Replacing the heat-sink”.

Step 7. To remove the microprocessor **3** from the system board, press then slide the small handle out to spring it up. **1** and open the retainer. **2**

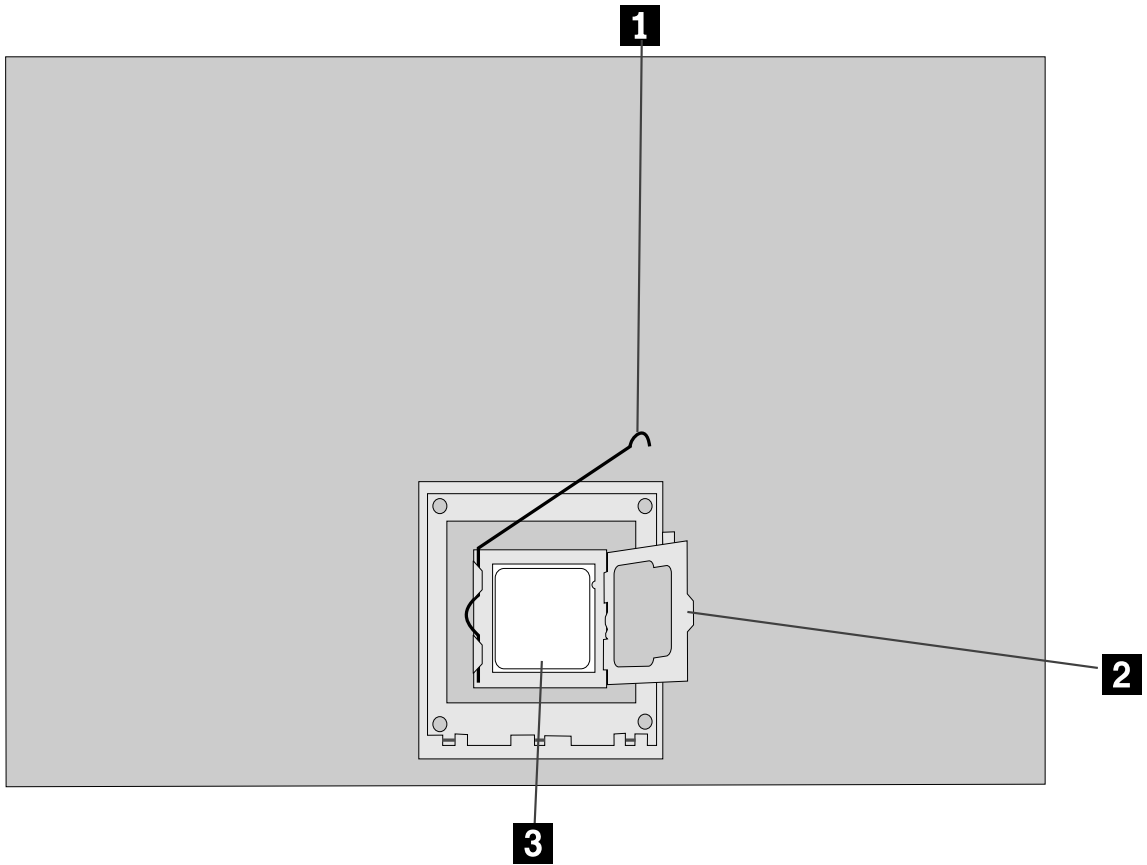

Attention: Do not touch the gold contacts on the bottom of the microprocessor. When handling the microprocessor, touch only the sides.

Note: Do not drop anything onto the microprocessor socket while it is exposed. The socket pins must be kept as clean as possible.

Step 8. Holding the sides of the microprocessor with your fingers, remove the protective cover **1** that protects the gold contacts on the new microprocessor. **2**

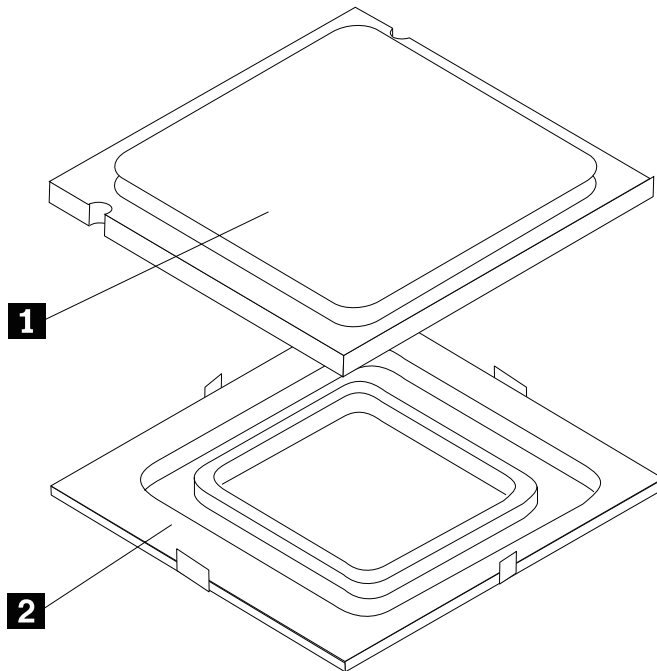

Step 9. Holding the sides of the microprocessor with your fingers, position the microprocessor so that the notches on the microprocessor are aligned with the tabs in the microprocessor socket.

Important: To avoid damaging the microprocessor contacts, keep the microprocessor completely level while installing it into the socket.

Step 10. Lower the microprocessor straight down into its socket on the motherboard.

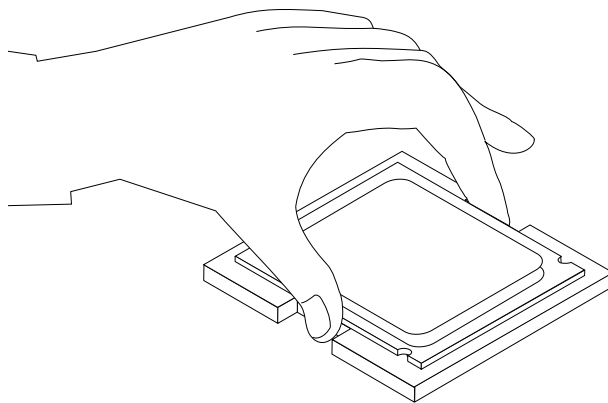

Step 11. To secure the microprocessor in the socket, close the microprocessor retainer and lock it into position with the small handle.

Step 12. Use a thermal grease syringe to place 5 drops of grease on the top of the microprocessor. Each drop of grease should be 0.03ml (3 tick marks on the grease syringe).

Step 13. Reattach the heat-sink, microprocessor fan, computer cover.

Replacing the Wi-Fi card

Note: For this procedure, it helps to lay the computer flat.

To replace the Wi-Fi card:

- Step 1. Remove any media (disks, CDs, DVDs, or memory cards) from the drives, shut down the operating system, and turn off the computer and all attached devices.
- Step 2. Unplug all power cords from electrical outlets.
- Step 3. Disconnect all cables attached to the computer. This includes power cords, input/output (I/O) cables, and any other cables that are connected to the computer. Refer to “Left and right view” and “Rear view” for help with locating the various connectors.
- Step 4. Remove the computer cover. Refer to “Removing the computer cover”.
- Step 5. Disconnect the 2 antenna cables from the Wi-Fi card.
- Step 6. Remove the 2 screws that secure the Wi-Fi card to the motherboard.
- Step 7. Pull the Wi-Fi card upward to remove it from the card port.

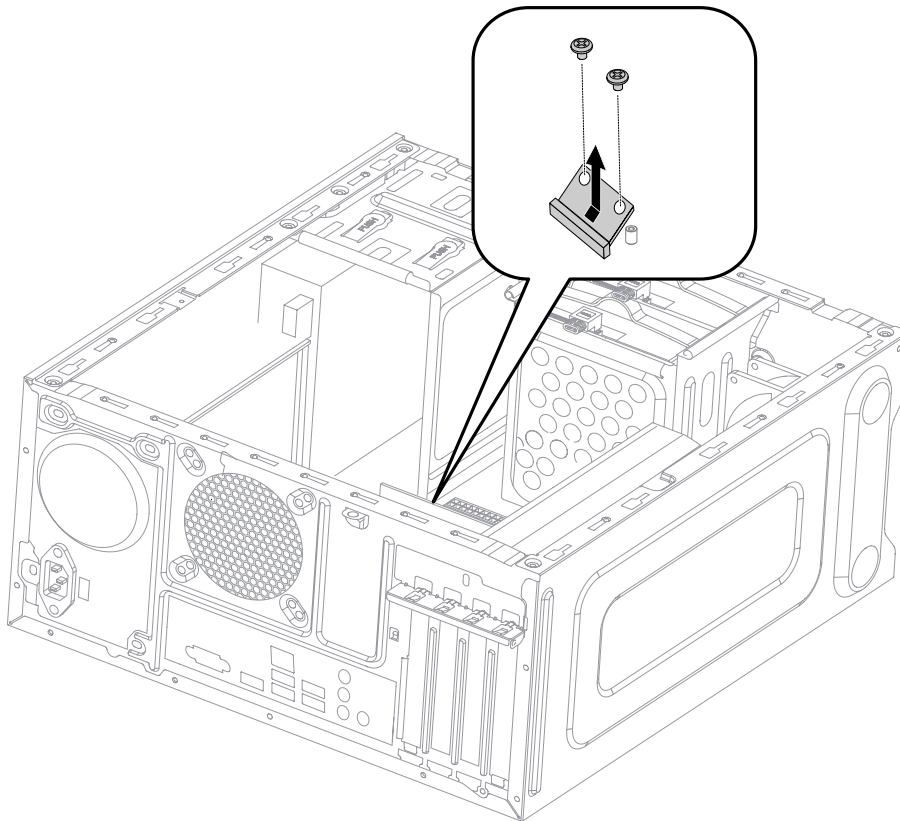

- Step 8. Install the new Wi-Fi card:
 - a. Line up the new Wi-Fi card, then insert it into the same card port.
 - b. Secure the Wi-Fi card to the motherboard with the 2 screws.
 - c. Connect the 2 antenna cables to the new Wi-Fi card.
- Step 9. Reattach the computer cover.

Replacing the motherboard

Note: For this procedure, it helps to lay the computer flat.

To replace the motherboard:

- Step 1. Remove any media (disks, CDs, DVDs, or memory cards) from the drives, shut down the operating system, and turn off the computer and all attached devices.
- Step 2. Unplug all power cords from electrical outlets.
- Step 3. Disconnect all cables attached to the computer. This includes power cords, input/output (I/O) cables, and any other cables that are connected to the computer. Refer to “Left and right view” and “Rear view” for help with locating the various connectors.
- Step 4. Remove the computer cover. Refer to “Removing the computer cover”.
- Step 5. Remove the memory module. Refer to “Replacing a memory module”.
- Step 6. Remove the microprocessor fan. Refer to “Replacing the microprocessor fan”.
- Step 7. Remove the heat-sink. Refer to “Replacing the heat-sink”.
- Step 8. Remove the graphic card. Refer to “Replacing a graphic card”.
- Step 9. Remove the Wi-Fi card. Refer to “Replacing the Wi-Fi card”.
- Step 10. Remove the CPU. Refer to “Replacing the CPU”.
- Step 11. Disconnect the all cables from the connectors on motherboard.
- Step 12. Remove the 8 screws that secure the motherboard to the chassis.
- Step 13. Slide then lift the motherboard out of the chassis to remove it.

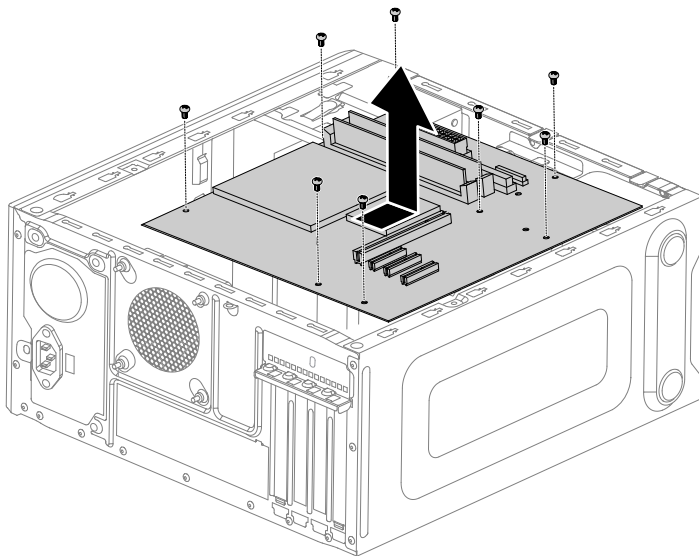

- Step 14. Install the new motherboard:
 - a. Line up the holes on the new motherboard with mounting holes on the chassis and secure it with screws.
 - b. Reattach the memory module, Wi-Fi card, CPU, and the heat-sink to the new motherboard.
 - c. Connect the all cables to the new motherboard.
 - d. Attach the graphic card to the new motherboard.
- Step 15. Reattach the computer cover.

FRU lists

This chapter lists the information on the field replaceable units (FRUs).

Attention: Be sure to read and understand all the safety information before replacing any FRUs.

Notes: FRUs that have a 1 or 2 in the CRU column are Customer Replaceable Units (CRUs).

- **1**– identifies parts that are fairly simple to replace, requiring few or no tools.
- **2**– identifies parts that are slightly more difficult to replace.
- **N**-identifies parts that are not to be replaced by the customer.

Item #	Description	Lenovo P/N	CRU ID
	CPU		N
	I I7-4770 3.4/1600/8/1150 84 CPU	1100783	
	I I5-4570 3.2/1600/6/1150 84 CPU	1100786	
	I I5-4440 3.1/1600/4C/6M/1150 84 CPU	1100949	
	I I3-4330 3.5/1600/2C/4M/1150 54 CPU	1100929	
	I I3-4130 3.4/1600/2C/3M/1150 54 CPU	1100930	
	I I7-4790 3.6/1600/4C/8M/1150 84W CPU	1101104	
	I I5-4590 3.3/1600/4C/6M/1150 84W CPU	1101106	
	I I5-4460 3.2/1600/4C/6M/1150 84W CPU	1101107	
	I I3-4160 3.6/2C/3M/1600 1150 54W CPU	SSA0F66603	
	I I3-4150 3.5/1600/2C/3M/1150 54W CPU	1101088	
	MB		N
	NOK M B85 MP Refresh MB	5B20G00906	
	W8S M B85 MP Refresh MB	5B20G00892	
	W8P M B85 MP Refresh MB	5B20G00893	
	NOK M B85 MATX MB	90003258	
	W8S M B85 MATX MB	90003259	
	W8P M B85 MATX MB	90003260	
	Thermal		N
	TSL CEL3102836A6 Intel 65/95W Cooler	31045550	
	DWPH Intel 65/95W Cooler	31506282	
	Foxconn PKP734G01K12Z intel 65 Coolerkit	31045548	
	AVC Z8UL06S012 Intel 65/95W Cooler	31045549	
	LX 460 mm feeling Wen Xian's 6 pins®	31034561	
	GS 460mm sensor cable w_6pin®	31045784	
	FOX PV902512PSPF 0JG2 9225 Sysfan(R)	31039640	
	AVC DS09225R12HP183 9225 Sysfan(R)	31039310	
	Front Fan		N
	AVC DS09225R12HP251 Frontfan	31500949	

	RAM		2
	M378B5173DB0-CK0 4GB D3 -1600 Memory-HF	1100944	
	HMT451U6BFR8C-PB 4GB D3-1600 Memory-HF	1100988	
	MT8JTF51264AZ-1G6E1 4GB D3-1600 Memory	1100955	
	Mic_R D9QBJ 4GB D3L-1600 M2 Memory	1100807	
	Mic_S D9QBJ 4GB D3-1600 M2 Memory	1100682	
	M378B1G73DB0-CK0 8GB D3 -1600 Memory-HF	1100945	
	HMT41GU6BFR8C-PB 8GB D3-1600 Memory-HF	1100989	
	MT16JTF1G64AZ-1G6E1 8GB D3-1600 Memory	1100669	
	Mic_R D9QBJ 8GB D3L-1600 Memory-HF	1101011	
	HDD		2
	WDXL500A WD5000AAKX-08U6AA0 500G HDD-LH	16200544	
	SGT Pharaoh 4K ST500DM002 500G HDD-LH	16200178	
	TSB Mars 4K 500G DT01ACA050 -LH	16200512	
	3.5inch SATA6G 7.2K Grenada BP 1.5 1TB	16200528	
	WD XL1000B WD10EZEX-08M2NA0 1TB HDD	16200613	
	TSB Mars 4K 1TB DT01ACA100 -LH	16200513	
	3.5inch SATA6G 7.2K Grenada BP 1.5 2TB	16200529	
	SGT Grenada BP ST2000DM001 2TB HDD-LH	16200294	
	TSB Mars 4K 2TB DT01ACA200 -LH	16200514	
	SSHD		2
	Seagate Grenada 1TB ST1000DX001 SSHD-LH	16200534	
	Seagate Grenada 2TB ST2000DX001 SSHD-LH	16200535	
	SSD		2
	SS MZ7TE256HMHP 256G 2.5" SSD	16200605	
	Lite-on LCS-256M6S 256GB SATA SSD	16200488	
	ODD		2
	HLDS DH50N HH SATA DVD-ROM-LH	25210649	
	TSST 16XSH-116BB SATA Black DVDROM-LH	25213719	
	PLDS 16XDH-16D7SH HH SATA DVDROM-LH	25205800	
	TSST 16XSH-116CB SATA DVDROM-LH	25216227	
	PSN SW430 HH SATA DVDROM-LH	25214498	
	PLDS 16XDH-16AESH SATA Black DVDRW-LH(LSOPU)	25213061	
	TSST SH-216DB HH SATA Rambo ODD-LH	25213720	
	Panasonic 16XSW830 HH SATA DVDRW-LH	25213885	
	HLDS GHB0N HH SATA Rambo-LH	25214470	
	HLDS BH40N Blu-ray Recorder-LH(BE)	25210651	

Graphics		2
Bitland@Geforce GTX 760@2G/A/2D/DP/H Graphics	11202298	
JT LX-319 K4 Chassis Universal Graphics bracket	31500767	
MSI@Geforce GTX 750@2G/A/2D/mHDMI Graphics	11202804	
MSI@Geforce GTX 745@2G/A/DB/H Graphics	11202802	
MSI@Geforce GT 720@2G/A/DB/H Graphics	11202746	
Bitland@Geforce GT 705@1G/A/DB/H Graphics	11202742	
MSI@Geforce GT 705@1G/A/DB/H Graphics	11202743	
MGE 4pin to 6pin power cable 150mm	31504075	
Bitland@R5 235@1G/A/DB/H Graphics	11202403	
MSI@R5 235@1G/A/DB/H Graphics	11202404	
Bitland@R5 235@2G/A/DB/H Graphics	11202748	
Bitland@R7 240@2G/A/DB/H Graphics	11202407	
VIDEO_CARD M@R9 260@2G/A/DB/D/DP/H	SV10G52022	
VIDEO_CARD B@Geforce GTX 750Ti@2G/A/DBDH	SV10G52021	
MSI@R9 255@2G/A/D/DP/H Graphics	11202506	
PSU		N
Huntkey HK280-22GP S5 PS3 180W PSU	36200083	
Acbel API6PC06-EL3G PS3 180W PSU	36200084	
Liteon PS-5181-8VS2-ROHS PS3 180W PSU	36200085	
New cable LC PS3 180W FSP180-50PSA PSU®	36200438	
ACBEL PC8061-EL2G WW 180W PSU	36200488	
LITEON PS-5181-09VS WW 180W PSU	36200489	
ACBEL PC6001-EL9G ATX 280W PSU	36200498	
LITEON PS-5281-7VR5 ATX 280W PSU	36200499	
HK HK380-12GP S2(S7) ATX 280W PSU	36200500	
ACBEL PC9008-EL1G ATX 280W ES PSU	36200501	
LITEON PS-5281-02VA ATX 280W ES PSU	36200502	
FSP FSP280-50EPA ATX 280W ES PSU	36200503	
ACBEL PC7033-EL2G 450W PSU	36200597	
Card Reader		N
Taisol GL827S 7in1 L_Single_CR	11201222	
Bitland RTS5179 7in1 L_Single_CR	11201223	
ODD Door cover		N
HongHai LX319 Chassis ODD Metal Baffle (R)	31046268	
USB/Audio Cable		N
LS USB3.0 F_IO cable_U530A650_36PIN	31507033	
CL USB3.0 F_IO cable_U530A650_36PIN	31507034	

	Chassis		N
	JT LX-328BT-23L Chassis	30500516	
	JT 328BT-23L Chassis	5C80G59224	
	JT 328BT-23L Chassis F/Bezel	5B30G59221	
	JT 328BT-23L HDD Bracket	5B40G59220	
	JT 328BT-23L USB USB&CR Bracket	5B40G59223	
	JT 328BT-23L Wlan Antenna Cover	5CB0G59219	
	JT B85 MB rearIO shielding	31503330	
	Kaveri A78 rear IO cover for X3	31506693	
	JT X3 LED Cable_630mm	31507035	
	MGE X3 LED Cable_630mm	31507036	
	HDD/ODD SATA cable		N
	GS 2H300mmSATA cable Latch®	31024767	
	LX 2H300mmSATA cable Latch®	31024785	
	GS 2H300mmSATA cable Latch®	31024767	
	LX 2H300mmSATA cable Latch®	31024785	
	LX 370mmSATA cable(R)	31034778	
	Guan Xu370mmSATA cable(R)	31034820	
	CL 2H420mmSATA calbe Latch®	31506478	
	MGE 2H420mmSATA calbe Latch(R)	31506479	
	LX 2H420mmSATA calbe Latch®	31024760	
	LS DVIDVI cable 1.8m	31501245	
	LX 200mmHDMI to DVIDS cable®	31041295	
	LX 130mm DVI-to-VGA cord®	31024556	
	PATA TO SATA CABLE		N
	GS 2H100mm 4pinSATA cable Latch®	31024761	
	LX 2H100mm 4pin-SATA cable Latch®	31024766	
	Rubber Cover		N
	JT VGA plastic cover	31049015	
	JT HDMI rubber cover	31049017	
	LI2323swA/TPV/A/R/WW 65A7-HB1	18201611	
	Speaker		1
	Lenovo speaker M0620 Black	25013742	
	Touch Pad		N
	Chicony TGR1226 2.4G touchpad BLK final	25212969	

Wifi & Antenna		N
Ltn RTL8723BE 1x1BGN+BT HMC WLAN	20200440	
Liteon WB335 1x1BGN+BT4.0 HMC WLAN	20200437	
LTN RTL8821AE 1x1ac+BT4.0 Combo HMC	11202485	
Cbt RTL8821AE 1x1AC+BT4.0 PCIE M.2 WLAN	20200571	
LS X310 Front Antenna	31507037	
LS X310 Rear Antenna	31507038	
JT M2X3 Dedicated Screw	31501076	
JT WiFi Antenna cover	31501130	
KB & Mouse		1
Sunrex EKB-10YA(US) B-Silk USB KB-LVT8	25209111	
Primax KB4721(US) B-Silk USB KB-LVT8	25209112	
Chicony KU-1153(US) B-Silk USB KB-LVT8	25209113	
Sunrex EKB-10YA(TW) B-Silk USB KB-LVT8	25209114	
Sunrex EKB-10YA(TH) B-Silk USB KB-LVT8	25209115	
Sunrex EKB-10YA(CZ-SL) B-S USB KB-LVT8	25209116	
Sunrex EKB-10YA(IN) B-Silk USB KB-LVT8	25209117	
Sunrex EKB-10YA(RU) B-Silk USB KB-LVT8	25209118	
Sunrex EKB-10YA(UK) B-Silk USB KB-LVT8	25209119	
Sunrex EKB-10YA(Nordic) B-S USB KB-LVT8	25209120	
Sunrex EKB-10YA(LA) B-Silk USB KB-LVT8	25209121	
Sunrex EKB-10YA(AR) B-Silk USB KB-LVT8	25209122	
Sunrex EKB-10YA(SW) B-Silk USB KB-LVT8	25209123	
Sunrex EKB-10YA(GE) B-Silk USB KB-LVT8	25209124	
Sunrex EKB-10YA(TR) B-Silk USB KB-LVT8	25209125	
Sunrex EKB-10YA(SP) B-Silk USB KB-LVT8	25209126	
Sunrex EKB-10YA(SL) B-Silk USB KB-LVT8	25209127	
Sunrex EKB-10YA(IT) B-Silk USB KB-LVT8	25209128	
Sunrex EKB-10YA(HB) B-Silk USB KB-LVT8	25209129	
Sunrex EKB-10YA(FR) B-Silk USB KB-LVT8	25209130	
Sunrex EKB-10YA(GK) B-Silk USB KB-LVT8	25209131	
Sunrex EKB-10YA(HG) B-Silk USB KB-LVT8	25209132	
Sunrex EKB-10YA(BG) B-Silk USB KB-LVT8	25209133	
Sunrex EKB-10YA(HR) B-Silk USB KB-LVT8	25209134	
Sunrex EKB-10YA(JP) B-Silk USB KB-LVT8	25209135	
Sunrex EKB-10YA(EN-FR) B-S USB KB-LVT8	25209136	
Sunrex EKB-10YA(PT) B-Silk USB KB-LVT8	25209137	
Sunrex EKB-10YA(BE-EN) B-S USB KB-LVT8	25209138	
Sunrex EKB-10YA(DU) B-S USB KB-LVT8	25209139	
Liteon LXH-SM-8825 B-Silk Mouse	25200528	

Sunrex LXH-EMS-10ZA B-Silk Mouse	25200530
Lenovo laser mouse M6811(B)	25013797
Primax M300 USB gesture mouse BLK	25213876
Liteon SK-8861(US) 2.4G KB-Black8	25209175
Liteon SK-8861(US-MY) 2.4G KB-Black8	25209176
Liteon SK-8861(TW) 2.4G KB-Black8	25209177
Liteon SK-8861(TH) 2.4G KB-Black8	25209178
Liteon SK-8861(CS-SK) 2.4G KB-Black8	25209179
Liteon SK-8861(US-IN) 2.4G KB-Black8	25209180
Liteon SK-8861(RU) 2.4G KB-Black8	25209181
Liteon SK-8861(GB) 2.4G KB-Black8	25209182
Liteon SK-8861(Nordic) 2.4G KB-Black8	25209183
Liteon SK-8861(LA) 2.4G KB-Black8	25209184
Liteon SK-8861(LA-AR) 2.4G KB-Black8	25209185
Liteon SK-8861(SA) 2.4G KB-Black8	25209186
Liteon SK-8861(CH) 2.4G KB-Black8	25209187
Liteon SK-8861(DE) 2.4G KB-Black8	25209188
Liteon SK-8861(TR) 2.4G KB-Black8	25209189
Liteon SK-8861(ES) 2.4G KB-Black8	25209190
Liteon SK-8861(SL) 2.4G KB-Black8	25209191
Liteon SK-8861(IT) 2.4G KB-Black8	25209192
Liteon SK-8861(IL) 2.4G KB-Black8	25209193
Liteon SK-8861(FR) 2.4G KB-Black8	25209194
Liteon SK-8861(GR) 2.4G KB-Black8	25209195
Liteon SK-8861(HU) 2.4G KB-Black8	25209196
Liteon SK-8861(BG) 2.4G KB-Black8	25209197
Liteon SK-8861(KR) 2.4G KB-Black8	25209198
Liteon SK-8861(JP) 2.4G KB-Black8	25209199
Liteon SK-8861(EN-FR) 2.4G KB-Black8	25209200
Liteon SK-8861(PT) 2.4G KB-Black8	25209201
Liteon SK-8861(BE-EN) 2.4G KB-Black8	25209202
Liteon SK-8861(DU) 2.4G KB-Black8	25209203
Liteon SM-8861(WW) Mouse Black	25203464
Liteon SM-8861 Mouse(No Battery) Black	25203465
Liteon SM-8861(JP) Mouse-Black	25205773
Liteon SM-8861 Mouse(MY) Black	25203466
Chicony KU-0603(US) USB gaming KB	25210203
Chicony KU-0603(IN) USB gaming KB	25216248
Newmen MS-172 USB gaming mouse black	25213791

Power Cord		1
LW BLK1.8m UL CSA Power Cord(R)	31026357	
LX(ASAP) 1.8M C13 UL power cord	31049521	
VL BLK1.8m UL CSA Power Cord®	31026145	
GS BLK1T1 1.8m CCC Power cord®	31028776	
LX(ASAP) 1.8M CCC C13 power cord®	31040179	
VL BLK1.8m BS Power Cord(R)	31026082	
LX(ASAP) 1.8M C13 UK power cord	31502861	
LW BLK1.8m BS Power Cord®	31026096	
VL BLK1.8m ANE Power Cord®	31026140	
LX(ASAP) 1.8M C13 ANZ power cord	31049524	
LW BLK1.8m ANE Power Cord®	31026350	
LW BLK1.8m VDE Power Cord®	31026355	
VL BLK1.8m VDE Power Cord®	31026144	
LX(ASAP) 1.8M C13 EU power cord	31049522	
LW BLK1.8m India power cord®	31033216	
LX(ASAP) 1.8M C13 INDIA power cord	31502871	
VL BLK1.8m BSMI Power Cord®	31026146	
LX(ASAP) 1.8M C13 BSMI power cord	31502867	
LW BLK1.8m BSMI Power Cord®	31026349	
Volex 1.8M C13 SA power cord	31049509	
LX(ASAP) 1.8M C13 SABS power cord	31502865	
LW BLK1.8m SABS Power Cord®	31031394	
Volex 1.8M C13 LA power cord	31049515	
LX(ASAP) 1.8M C13 ARGENTINA power cord	31502869	
LW1.8m C13 IRAM power cord®	31036980	
Volex 1.8M C13 BR power cord	31049513	
LX(ASAP) 1.8M C13 BRAZIL power cord	31502862	
LW1.8m C13 Brazil power cord®	31038784	
LW BLK1.8m KTL Power Cord®	31026351	
LX(ASAP) 1.8M C13 KOREA power cord	31502870	
VL BLK1.8m KTL Power Cord®	31026143	
Volex 1.8M C13 JPN power cord	31049514	
LX(ASAP) 1.8M C13 JPN power cord	31049523	
LW 1.8m JAPAN Power Cord®	31039730	
Volex 1.8M C13 ITY power cord	31049512	
LX(ASAP) 1.8M C13 ITALY power cord	31502864	
LW 1.8m Italy Power Cord®	31039726	
Volex 1.8M C13 DEN power cord	31049511	
LX(ASAP) 1.8M C13 DANMARK power cord	31502863	

LW 1.8m Denmark Power Cord®	31039729
LX(ASAP) 1.8M C13 Switzerland power cord	31502868
LW 1.8m Switzerland Power Cord®	31039732
Volex 1.8M C13 SWI power cord	31049516
Volex 1.8M C13 ISI power cord	31049510
LX(ASAP) 1.8M C13 ISRAEL power cord	31502866
LW 1.8m Israel Power Cord®	31039728

Chapter 9. General information

This chapter provides general information that applies to all machine types supported by this publication.

Additional Service Information

This chapter provides additional information that the service representative might find helpful.

Power management

Power management reduces the power consumption of certain components of the computer such as the system power supply, processor, hard disk drives, and some monitors.

Advanced configuration and power interface (ACPI) BIOS

As this computer has an ACPI BIOS system, the operating system is allowed to control the power management features of the computer and the settings for Advanced Power Management (APM) BIOS mode is ignored. Not all operating systems support ACPI BIOS mode.

Automatic Power-On features

The Automatic Power-On features within the Power Management menu allow you to enable and disable features that turn on the computer automatically.

- **Wake Up on Alarm:** You can specify a date and time at which the computer will be turned on automatically. This can be either a single event, a daily event or a weekly event.
- **Wake Up on LAN:** This feature allows LAN adapter card to wake the System.