

ThinkCentre[®]

M715q

User Guide and Hardware Maintenance Manual

Machine Type (MT):

10M2, 10M3, 10M4, 10M5, 10RA, 10RB, 10RC, 10RD

Energy Star MT:

10M2, 10M3, 10M4, 10M5, 10RA, 10RB, 10RC, 10RD



Overview >

Locations of indicators, connectors, and controls provided on your computer.



Locking the computer >

Locking devices for your computer.



Specifications >

Specifications of your computer.



Replaceable parts >

Locations of the replaceable parts on your computer.



Replacing customer replaceable units >

Replacing instructions for customer replaceable units.



Replacing field replaceable units >

Replacing instructions for field replaceable units (for technicians only).



Contents

Overview 3

Front view.....	3
Rear view.....	4
System board.....	6
Machine type and model label.....	7

Locking the computer..... 8

Locking the computer cover.....	8
Attaching a Kensington-style cable lock.....	8

Specifications..... 9

Replacing hardware..... 10

Before replacing hardware.....	10
Handling static-sensitive devices.....	10
Knowing replaceable parts.....	11
Customer-Replaceable Units (CRUs).....	11
Field-Replaceable Units (FRUs).....	11
CRUs and FRUs locations.....	12

Replacing customer-replaceable units (CRUs) 15

Before replacing CRUs.....	15
Replacing the power adapter.....	17
Replacing the vertical stand.....	18
Replacing the VESA mount bracket.....	20
Replacing the external optical drive.....	21
Replacing the I/O box.....	23
Replacing the power adapter bracket.....	24
Removing the computer cover.....	25
Replacing the system fan.....	26
Replacing the internal speaker.....	27
Replacing the storage drive bracket.....	28
Replacing the 2.5-inch storage drive.....	29
Replacing the M.2 storage drive.....	30

Replacing the memory module.....	32
Replacing the coin-cell battery.....	33
Replacing the Wi-Fi card.....	34
Replacing the wireless mouse.....	37
Replacing the wireless keyboard.....	39
Completing the parts replacement.....	40

Replacing field-replaceable units (FRUs)..... 41

Before replacing FRUs.....	41
Replacing the internal speaker holder.....	43
Replacing the heat sink.....	44
Replacing the microprocessor.....	45
Replacing the front Wi-Fi antenna.....	47
Replacing the rear Wi-Fi antenna.....	48
Replacing the system board.....	49

Notices & Trademarks 51

Notices.....	51
Trademarks.....	52

Overview

Front view



Note

Your computer model might look slightly different from the illustration.

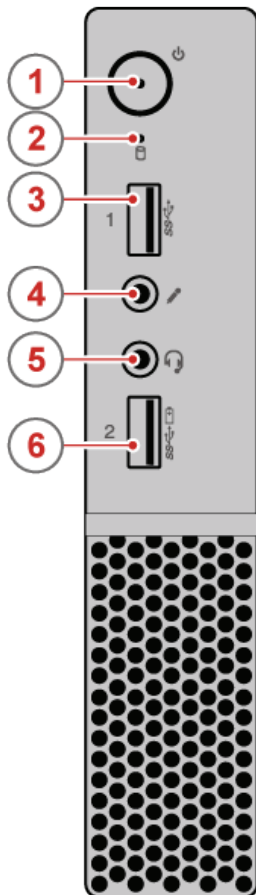

- 1 Power button**

Used to turn on your computer. You also can use the power button to turn off your computer when you cannot use the Microsoft® Windows® shutdown procedure normally to turn off your computer.
- 2 Storage drive status indicator**

This indicator is on when the storage drive is in use.
- 3 USB 3.0 connector**

Used to connect a device, such as a keyboard, mouse, scanner, printer, or PDA, that requires a USB 2.0 or USB 3.0 connection.
- 4 Microphone connector**

Used to connect a microphone to your computer. You can use the microphone to record sounds or use speech-recognition software.
- 5 Headset connector**

Used to connect a headset or headphones to your computer.
- 6 Always On USB 3.0 connector**

Used to connect a device that requires a USB 2.0 or USB 3.0 connection, such as a keyboard, a mouse, a scanner, a printer, or a personal digital assistant (PDA). With the power adapter connected, you can charge the automatically detected device even when the computer is in hibernation mode or turned off. If the Always On USB connector function is not enabled, open the Power Manager program and enable the function. To open the Power Manager program, see “Accessing a program on the computer” on page 38. To enable the Always On USB connector, refer to the help system of the Power Manager program.

Rear view



Note

Your computer model might look slightly different from the illustration.

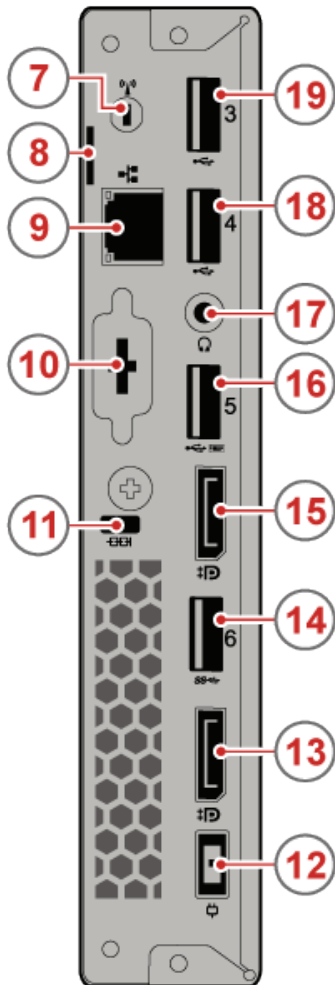

- 7 Wi-Fi antenna slot**
Used to install the rear Wi-Fi antenna cable connector that is optional. The rear Wi-Fi antenna is installed on the rear Wi-Fi antenna cable connector.

- 8 Padlock loop**
Used to secure a padlock.

- 9 Ethernet connector**
Used to connect an Ethernet cable for a LAN.

- 10 Optional connector (optional)**
Optional connector, depending on your computer model.

- 11 Security-lock slot**
Used to secure a Kensington-style cable lock.

- 12 Power adapter connector**
Used to connect the power adapter to your computer for power supply.

- 13 DisplayPort® connector**
Used to send or receive audio and video signals. An audio or video device, such as a high-performance monitor, can be attached to this connector.

- 14 USB 3.0 connector**
Used to connect a device, such as a keyboard, mouse, scanner, printer, or PDA, that requires a USB 2.0 or USB 3.0 connection.

- 15 DisplayPort connector**
Used to send or receive audio and video signals. An audio or video device, such as a high-performance monitor, can be attached to this connector.

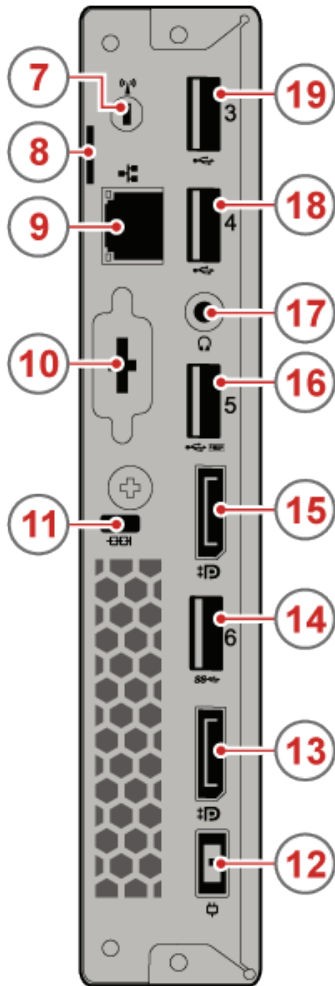

16

USB 2.0 connector

Used to connect a device, such as a keyboard, mouse, scanner, printer, or PDA, that requires a USB 2.0 connection. This USB 2.0 connector supports the smart power on feature that enables you to turn on the computer or wake it up from S4 hibernation mode by pressing Alt+P on the keyboard. You can enable or disable the smart power on feature from the Setup Utility program.

17

Headphone connector

Used to connect headphones to your computer.

18

USB 2.0 connector

Used to connect a device, such as a keyboard, mouse, scanner, printer, or PDA, that requires a USB 2.0 connection.

19

USB 2.0 connector

Used to connect a device, such as a keyboard, mouse, scanner, printer, or PDA, that requires a USB 2.0 connection.

System board



Note

See [Front view](#) or [Rear view](#) for additional component descriptions.

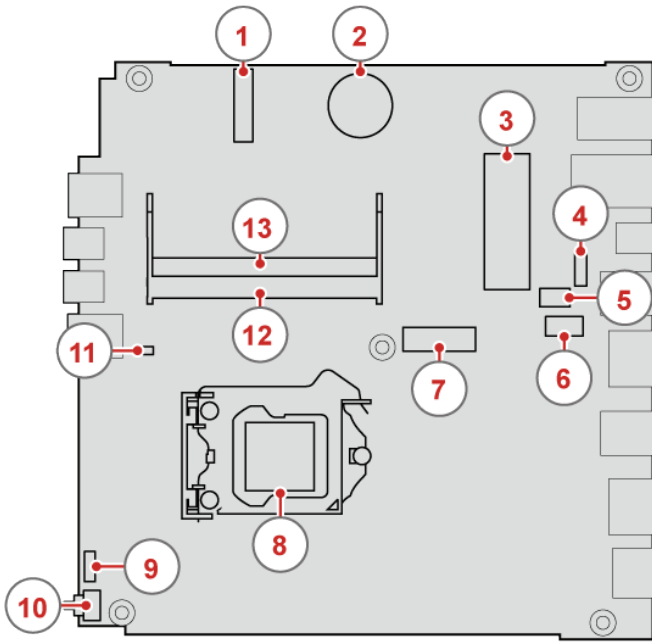

- 1 M.2 Wi-Fi card slot
- 2 Coin-cell battery
- 3 SATA 3.0 storage drive connector
- 4 System fan connector
- 5 Optional serial connector
- 6 Optional display connector
- 7 M.2 storage drive slot
- 8 Microprocessor socket
- 9 Thermal sensor
- 10 Cover presence switch connector (Intrusion switch connector)
- 11 Internal speaker connector
- 12 Memory slot (DIMM 1)
- 13 Memory slot (DIMM 2)

Machine type and model label

The machine type and model label identifies the computer. When you contact Lenovo for help, the machine type and model information helps support technicians to identify the computer and provide faster service.

The machine type and model label is attached on the side of the computer as shown.

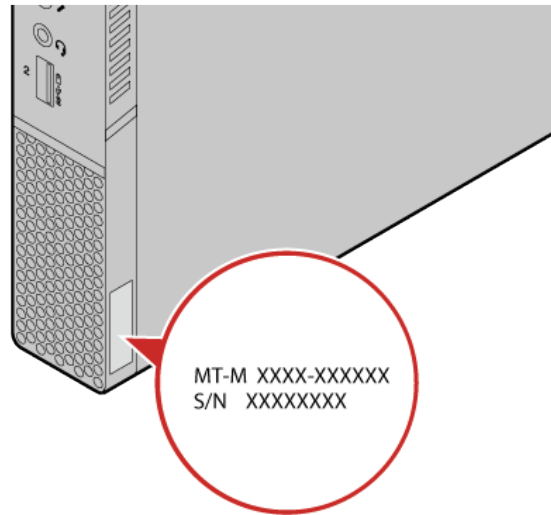

Locking the computer

Locking the computer cover

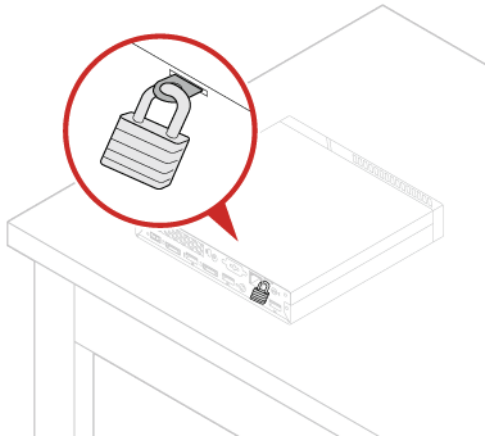

Locking the computer cover helps prevent unauthorized access to the inside of your computer. Your computer features a padlock loop so that the computer cover cannot be removed when a padlock is installed.

Attaching a Kensington-style cable lock

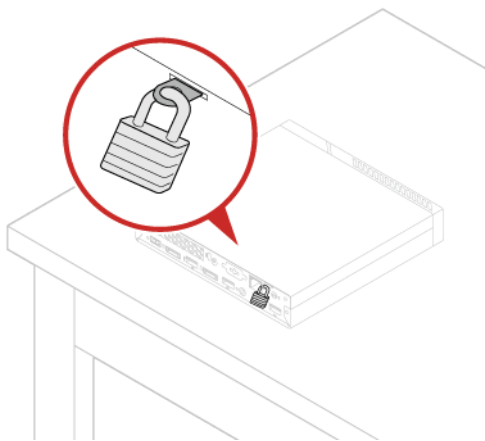

You can use a Kensington-style cable lock to secure your computer to a desk, table, or other nonpermanent fixture. The cable lock connects to the security-lock slot at the rear of your computer. Depending on the type selected, the cable lock can be operated with a key or combination. The cable lock also locks the buttons used to open the computer cover. This is the same type of lock used with many notebook computers. You can order such a cable lock directly from Lenovo by searching for Kensington at: <http://www.lenovo.com/support>.

Specifications

Power supply	<ul style="list-style-type: none">• 65-watt power adapter• 90-watt power adapter
Storage drives	Up to two storage drives
Video features	The integrated graphics card supports the following: <ul style="list-style-type: none">• DisplayPort connectors• VGA connector (optional)
Audio features	The integrated audio card supports the following: <ul style="list-style-type: none">• Headphone connector• Headset connector• Internal speaker• Microphone connector
Input/Output (I/O) features	<ul style="list-style-type: none">• Audio connectors (headphone connector, headset connector, and microphone connector)• Display connectors (DisplayPort connectors and VGA connector (optional))• Ethernet connector• Serial connector (optional)• USB connectors
Expansion	<ul style="list-style-type: none">• External optical drive box (optional)• Memory slots• Storage drive bay
Network features	<ul style="list-style-type: none">• Ethernet LAN• Wireless LAN (optional)• Bluetooth (optional)
Physical dimensions	<ul style="list-style-type: none">• Width: 35 mm (1.4 inches)• Height: 179 mm (7.0 inches)• Depth: 183 mm (7.2 inches)
Weight (without the package)	<ul style="list-style-type: none">• Maximum configuration as shipped: 1.3kg (2.9 lb)

Replacing hardware

Before replacing hardware



Attention

Do not open your computer or attempt any repairs before reading the *Important Product Information Guide*.

Read these notes before replacing hardware:

- Some of the hardware components explained in this manual are optional.
- Use computer components provided only by Lenovo.
- When installing or replacing an option, use the appropriate instructions explained in this manual along with the instructions that come with the option.
- In most areas of the world, Lenovo requires the return of defective CRUs (Customer Replaceable Units). Information about this will come with the CRU or will come a few days after the CRU arrives.

Handling static-sensitive devices

Do not open the static-protective package containing the new component until the defective component has been removed and you are ready to install the new component. Static electricity, although harmless to you, can seriously damage computer components.

When you handle parts and other computer components, take these precautions to avoid static damage:

- Limit your movement. Movement can cause static electricity to build up around you.
- Always handle parts and other computer components carefully. Handle PCI/PCI-Express cards, memory modules, system boards, and microprocessors by the edges. Never touch any exposed circuitry.
- Prevent others from touching the parts and other computer components.
- Touch the static-protective package containing the part to a metal expansion-slot cover or other unpainted metal surface on the computer for at least two seconds. This reduces static electricity from the package and your body before you install or replace a new part.
- When possible, remove the new part from the static-protective package, and install it directly in the computer without setting the part down. When this is not possible, place the static-protective package that the part came in on a smooth, level surface and place the part on the package.
- Do not place the part on the computer cover or other metal surface.

Knowing replaceable parts

Customer-Replaceable Units (CRUs)

CRUs are computer parts that a user can upgrade or replace. There are two types of CRUs: self-service and optional-service.

Self-service CRUs

You can install self-service CRUs easily. These CRUs might be standalone, latched, or secured by up to two screws.

Examples of self-service CRUs include the keyboard, mouse, any USB device, and the power cord. Other self-service CRUs might include memory modules, adapter cards, hard disk drives, and optical drives.



Note

Users are responsible for replacing all self-service CRUs.

Optional-service CRUs

Handling optional-service CRUs requires some technical skills and simple tools (such as a screwdriver).

These CRUs are isolated parts within the computer. They are usually concealed by an access panel that is secured by more than two screws. You must remove the screws and panel to access the specific CRU.

Optional-service CRUs can be removed and installed by users or, during the warranty period, by a Lenovo service technician.

Field-Replaceable Units (FRUs)

FRUs are computer parts that a trained technician can upgrade or replace.

For detailed FRU information, such as the FRU part numbers and supported computer models, go to:

<http://www.lenovo.com/serviceparts-lookup>

CRUs and FRUs locations

Refer to the following illustrations to check the locations of CRUs and FRUs within the computer.



Note

Some of the following parts are optional on some models.

Self-service CRU

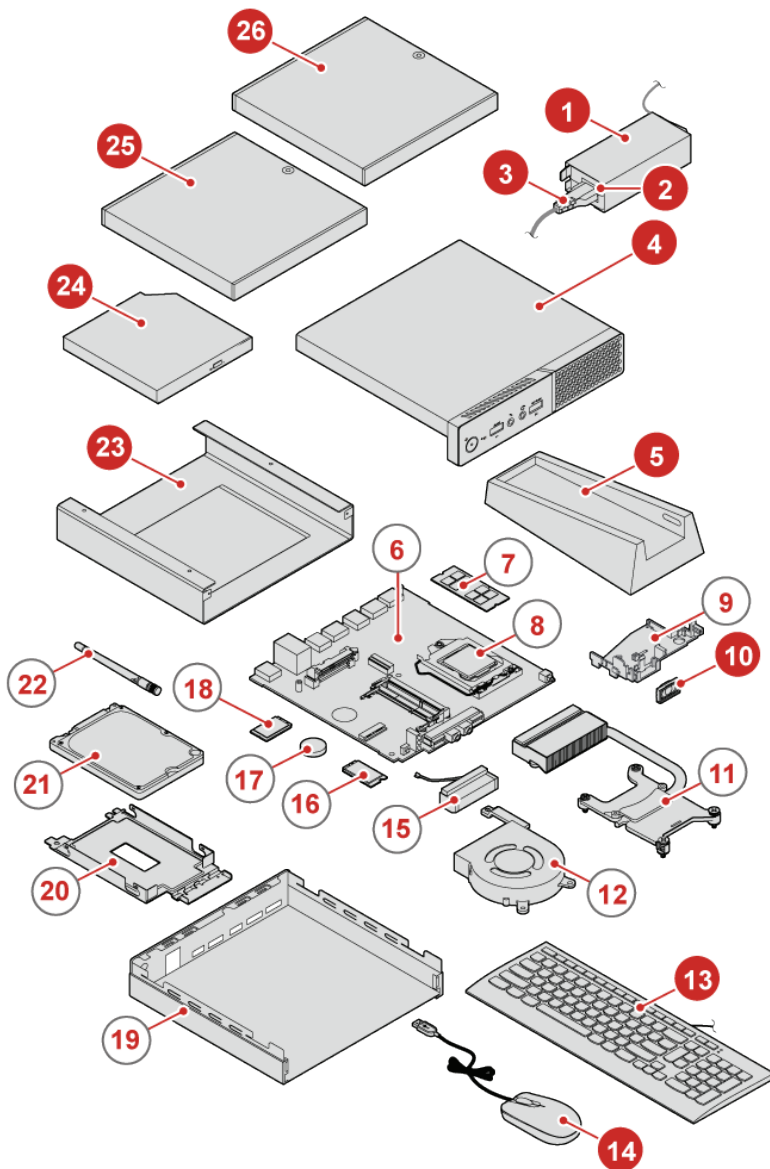

- 1 Power adapter bracket [p. 24](#)
- 2 Power adapter [p. 17](#)
- 3 Power cord [p. 17](#)
- 4 Computer cover [p. 25](#)
- 5 Vertical stand [p. 18](#)
- 10 Internal speaker [p. 27](#)
- 13 Keyboard [p. 39](#)
- 14 Mouse [p. 37](#)
- 23 VESA® mount bracket [p. 20](#)
- 24 External optical drive [p. 21](#)
- 25 External optical drive box [p. 21](#)
- 26 I/O box [p. 23](#)

Optional-service CRU

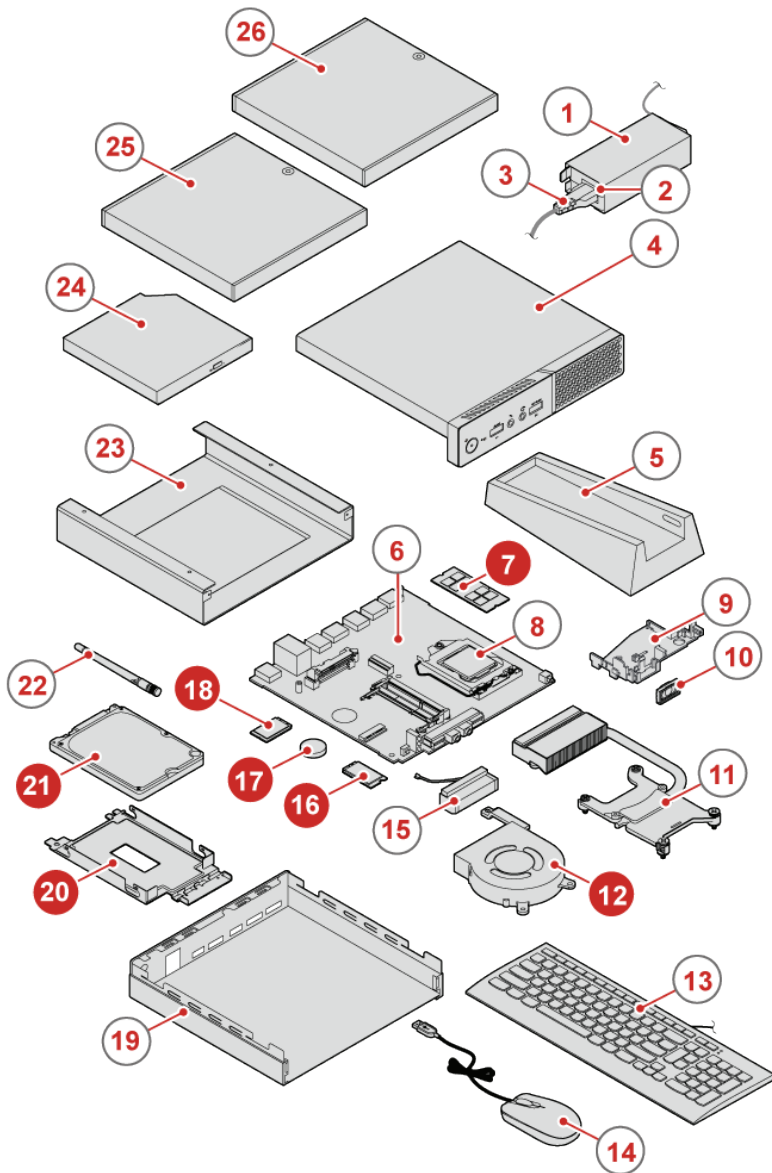

- 7 Memory module [p. 32](#)

- 12 System fan [p. 26](#)

- 16 Wi-Fi card [p. 34](#)

- 17 Coin-cell battery [p. 33](#)

- 18 M.2 storage drive [p. 30](#)

- 20 Storage drive bracket [p. 29](#)

- 21 2.5-inch storage drive [p. 29](#)

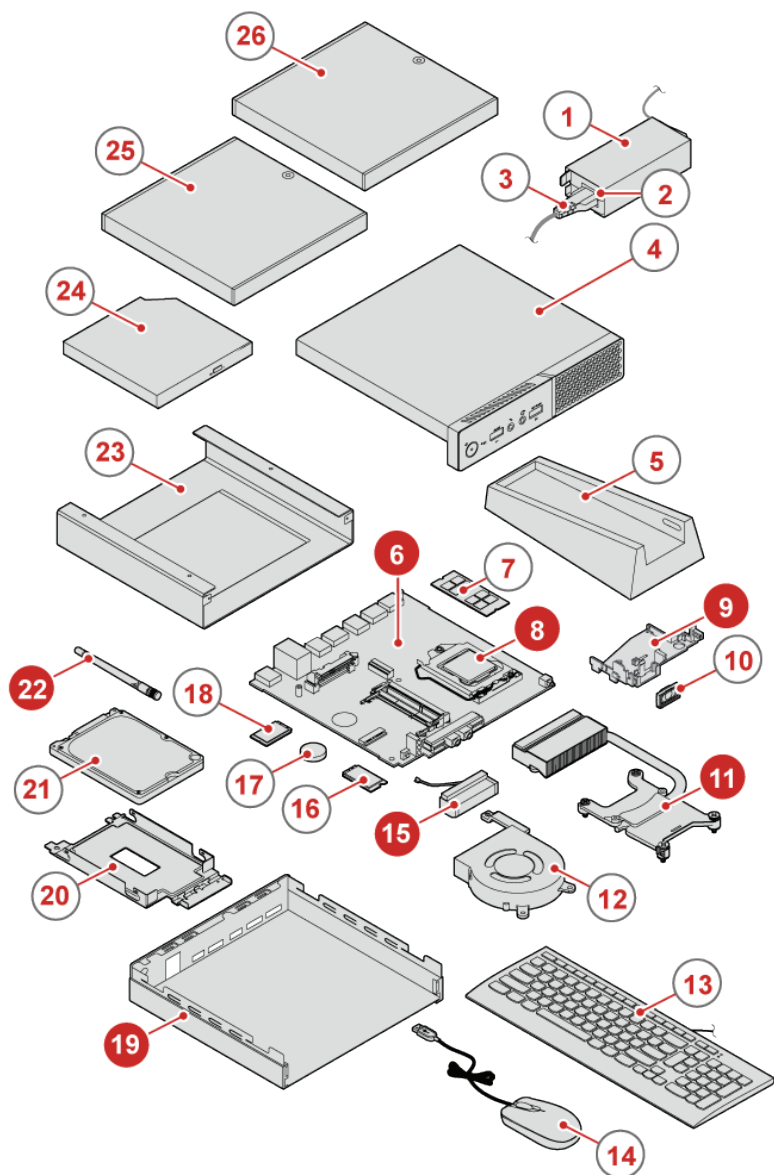

- 6** System board [p. 6](#)

- 8** Microprocessor [p. 45](#)

- 9** Internal speaker holder [p. 43](#)

- 11** Heat sink [p. 44](#)

- 15** Front Wi-Fi antenna [p. 47](#)

- 19** Chassis

- 22** Rear Wi-Fi antenna [p. 48](#)

Replacing customer-replaceable units (CRUs)

Before replacing CRUs

Customer Replaceable Units (CRUs) are computer parts that a user can upgrade or replace. There are two types of CRUs: self-service and optional-service.



Attention

Do not open your computer or attempt any repair before reading the *Important Product Information Guide*.

Before replacing a CRU, click the illustration of the part to check the brief procedures.

Mouse



Keyboard



Power adapter

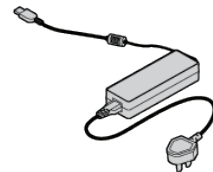

Vertical stand

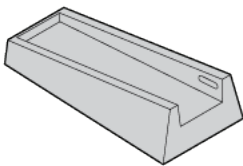

VESA mount bracket

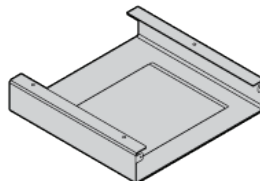

External optical drive

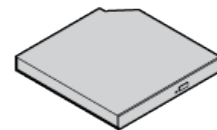

I/O box

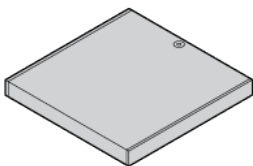

Power adapter bracket

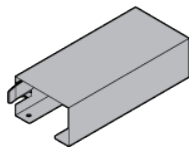

Computer cover

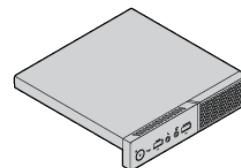

System fan

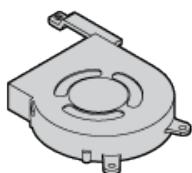

Internal speaker



2.5-inch storage drive

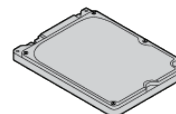

M.2 storage drive

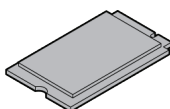

Memory module

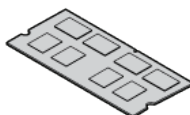

Coin-cell battery



Wi-Fi card

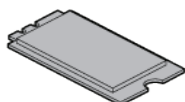

Note

To replace a component that is not in the list above, contact a Lenovo service technician. The support phone numbers are available at: <http://www.lenovo.com/support/phone>

Replacing the power adapter

Attention

Do not open your computer or attempt any repairs before reading the *Important Product Information Guide*.

- 1 Remove any media from the drives and turn off all connected devices and the computer. Then, disconnect all power cords from electrical outlets and disconnect all cables that are connected to the computer.
- 2 If the power adapter bracket is available, remove the power adapter bracket. See [Replacing the power adapter bracket](#).
- 3 Replace the power adapter.

1

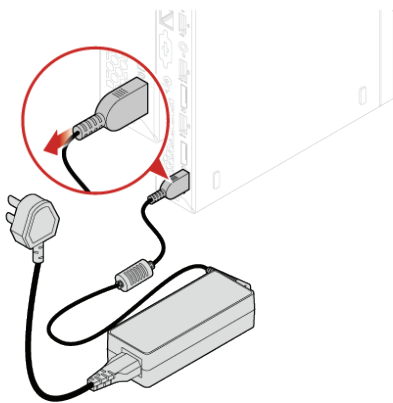

2

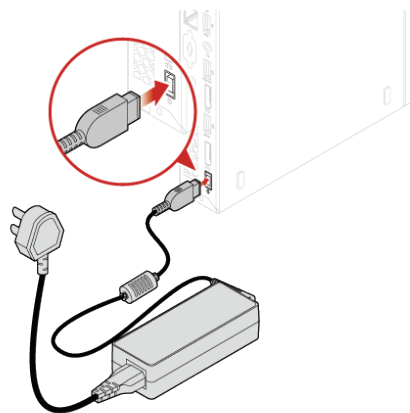

- 4 If the power adapter bracket is available, install the power adapter bracket. See [Replacing the power adapter bracket](#).

Replacing the vertical stand

Attention

Do not open your computer or attempt any repairs before reading the *Important Product Information Guide*.

1 Remove any media from the drives and turn off all connected devices and the computer. Then, disconnect all power cords from electrical outlets and disconnect all cables that are connected to the computer.

2 Replace the vertical stand.

- Type1

1

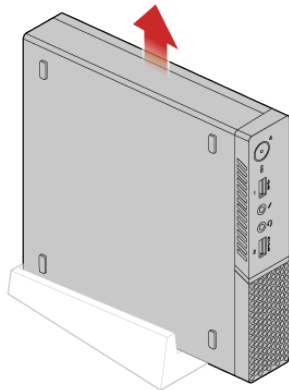

2

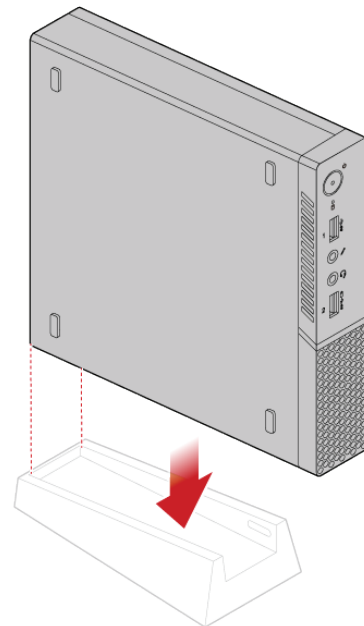

• Type2

1

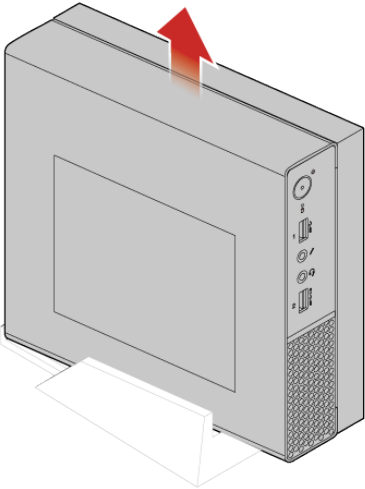

2

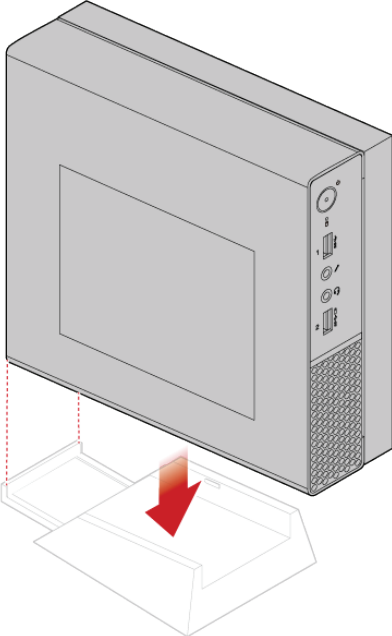

Replacing the VESA mount bracket

Attention

Do not open your computer or attempt any repairs before reading the *Important Product Information Guide*.

- 1 Remove any media from the drives and turn off all connected devices and the computer. Then, disconnect all power cords from electrical outlets and disconnect all cables that are connected to the computer.
- 2 If the power adapter bracket is available, remove the power adapter bracket. See [Replacing the power adapter bracket](#).
- 3 Replace the VESA mount bracket.

1

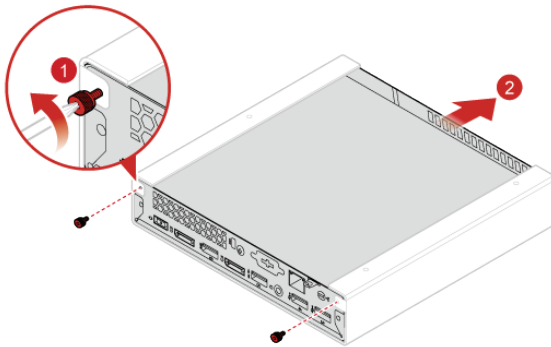

2

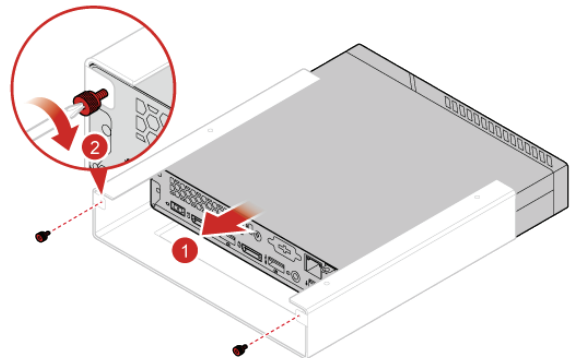

- 4 If the power adapter bracket is available, install the power adapter bracket. See [Replacing the power adapter bracket](#).

Replacing the external optical drive

Attention

Do not open your computer or attempt any repairs before reading the *Important Product Information Guide*.

- 1 Remove any media from the drives and turn off all connected devices and the computer. Then, disconnect all power cords from electrical outlets and disconnect all cables that are connected to the computer.
- 2 Disconnect the external optical drive adapter from the USB connectors on the external optical drive and the computer.
- 3 Replace the external optical drive.

1

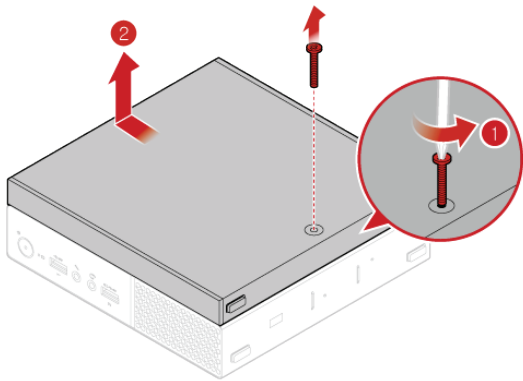

2

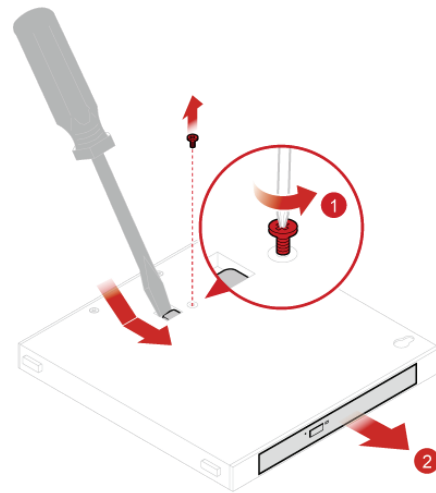

3

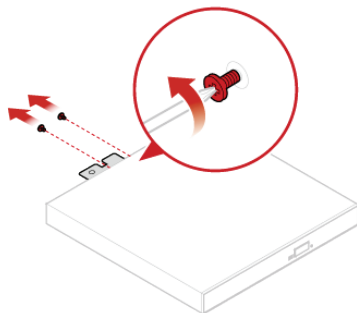

4

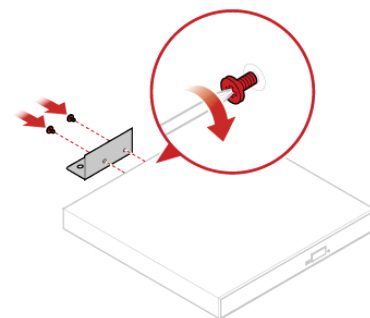

5

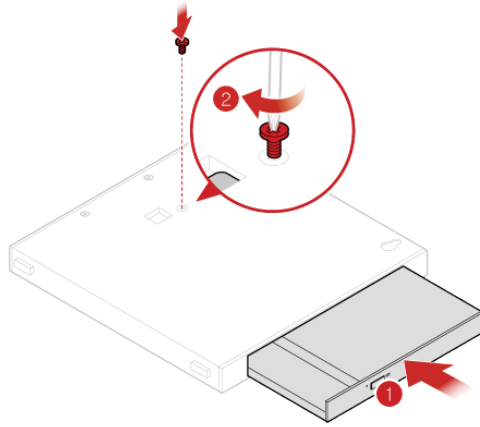

6

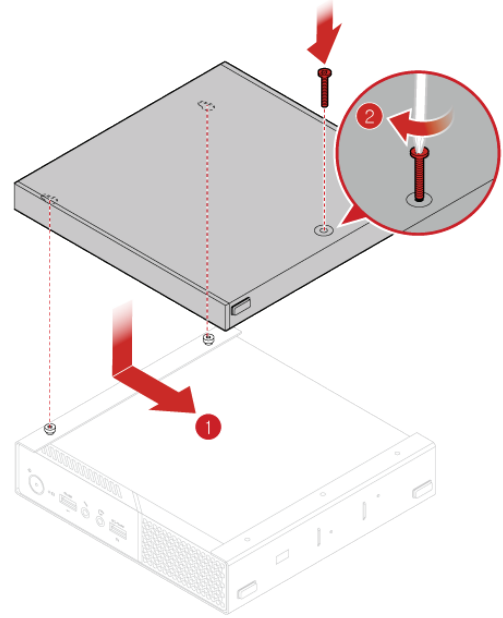

4 Connect the external optical drive adapter to the USB connectors on the external optical drive and the computer.

Replacing the I/O box



Attention

Do not open your computer or attempt any repairs before reading the *Important Product Information Guide*.

- 1 Remove any media from the drives and turn off all connected devices and the computer. Then, disconnect all power cords from electrical outlets and disconnect all cables that are connected to the computer.
- 2 Disconnect the I/O box cable from the USB connectors on the computer.
- 3 Replace the I/O box.

1

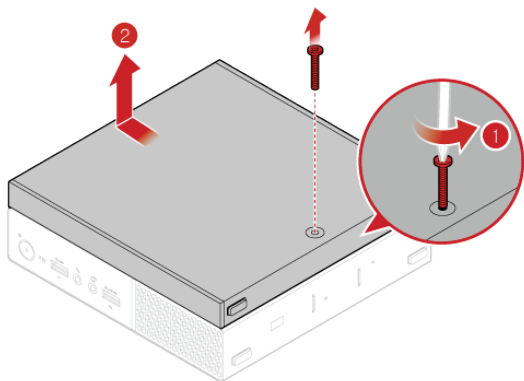

2

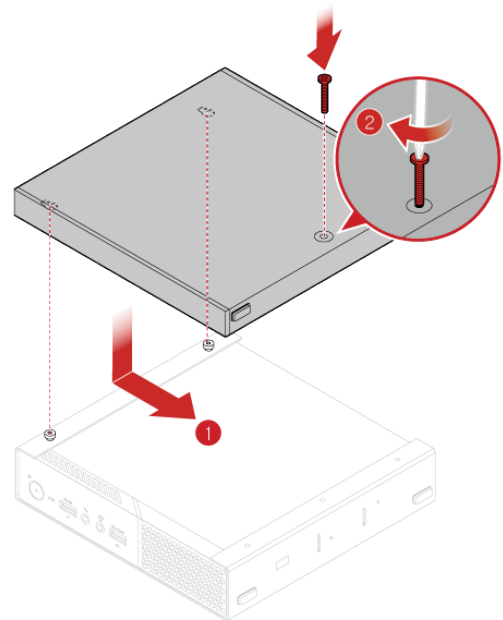

- 4 Connect the I/O box cable to the USB connectors on the computer.

Replacing the power adapter bracket



Attention

Do not open your computer or attempt any repairs before reading the *Important Product Information Guide*.



Note

The power adapter bracket is installed on the Video Electronics Standards Association (VESA) mount bracket.

- 1 Remove any media from the drives and turn off all connected devices and the computer. Then, disconnect all power cords from electrical outlets and disconnect all cables that are connected to the computer.
- 2 Replace the power adapter bracket.

1

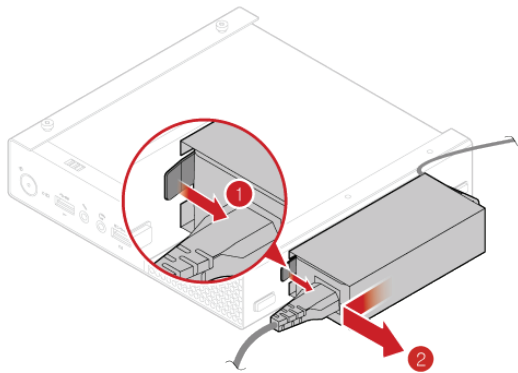

2

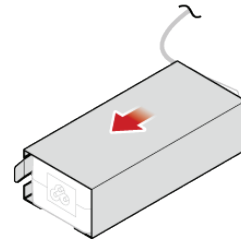

3

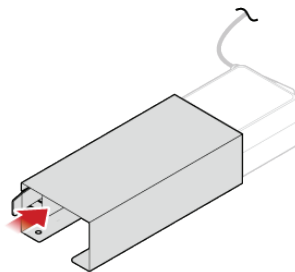

4

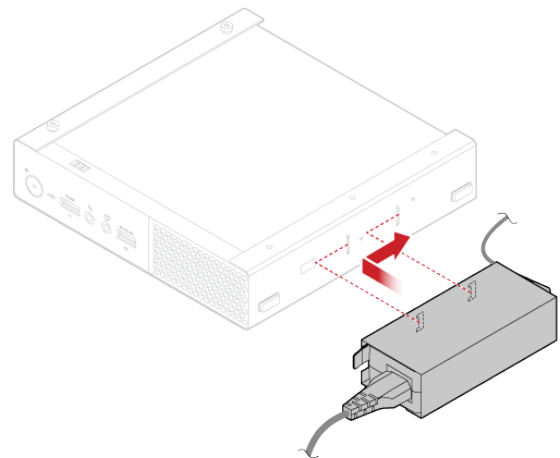

Removing the computer cover



Attention

Do not open your computer or attempt any repairs before reading the *Important Product Information Guide*.



Caution

Before you open the computer cover, turn off the computer and wait several minutes until the computer is cool.

- 1 Remove any media from the drives and turn off all connected devices and the computer. Then, disconnect all power cords from electrical outlets and disconnect all cables that are connected to the computer.
- 2 Hold the sides of your computer and gently lay it down so that the computer cover is facing up.
- 3 Unlock any locking device that secures the computer cover.
- 4 Remove the computer cover.

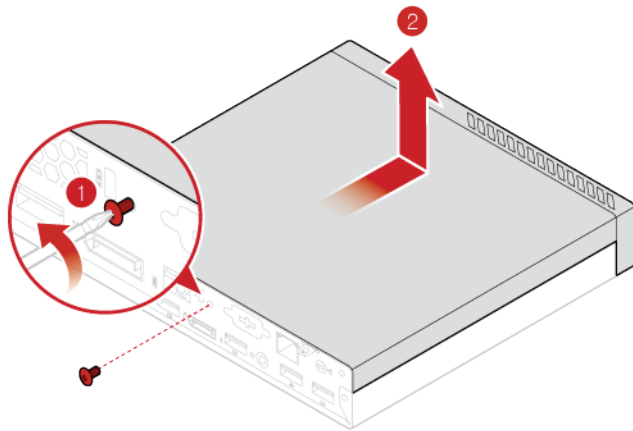

- 5 Reinstall the computer cover and reconnect the cables. For details, see **Completing the parts replacement.**

Replacing the system fan

Attention

Do not open your computer or attempt any repairs before reading the *Important Product Information Guide*.

- 1 Remove any media from the drives and turn off all connected devices and the computer. Then, disconnect all power cords from electrical outlets and disconnect all cables that are connected to the computer.
- 2 Remove the computer cover. For details, see [Removing the computer cover](#).
- 3 Record the routing and connection of the system fan cable, and then disconnect the cable from the system board.
- 4 Replace the system fan.

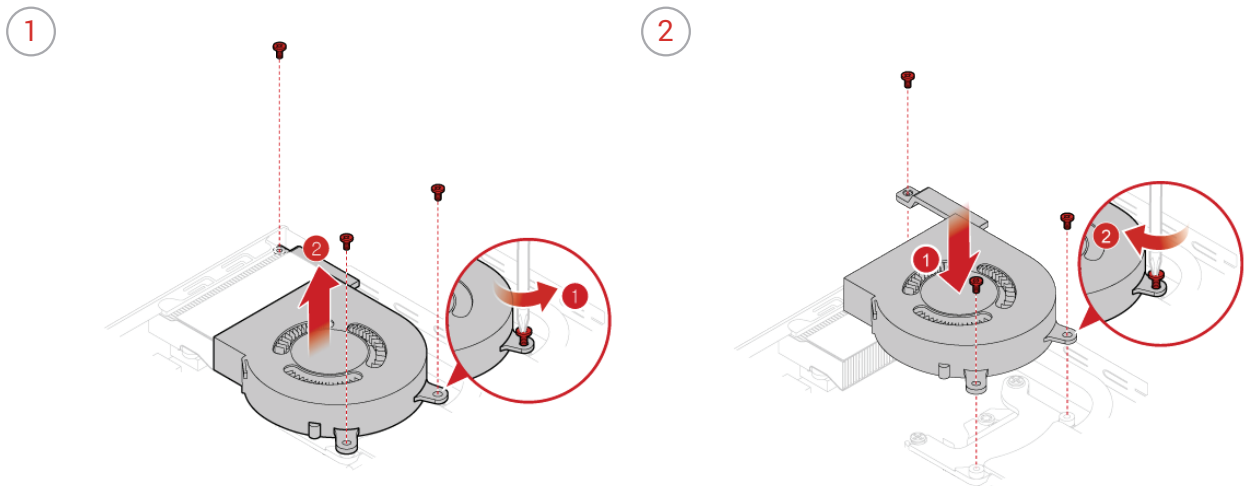

- 5 Connect the cable of the new system fan to the system fan connector on the system board.
- 6 Reinstall the computer cover and reconnect the cables. For details, see [Completing the parts replacement](#).

Replacing the internal speaker

Attention

Do not open your computer or attempt any repairs before reading the *Important Product Information Guide*.

- 1 Remove any media from the drives and turn off all connected devices and the computer. Then, disconnect all power cords from electrical outlets and disconnect all cables that are connected to the computer.
- 2 Remove the computer cover. For details, see [Removing the computer cover](#).
- 3 Record the routing and connection of the internal speaker cable, and then disconnect the cable from the system board.
- 4 Replace the internal speaker.

1

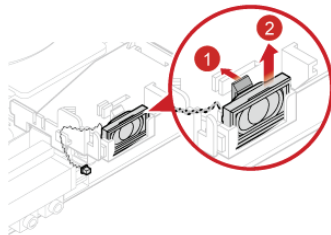

2

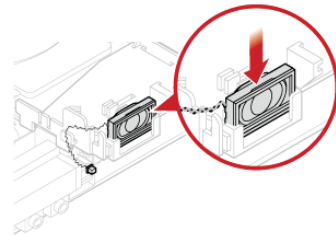

3

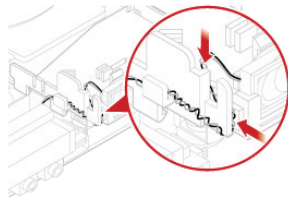

- 5 Connect the cable of the new internal speaker to the internal speaker connector on the system board.
- 6 Reinstall the computer cover and reconnect the cables. For details, see [Completing the parts replacement](#).

Replacing the storage drive bracket

! Attention

Do not open your computer or attempt any repair before reading the *Important Product Information Guide*.

- 1 Remove any media from the drives and turn off all connected devices and the computer. Then, disconnect all power cords from electrical outlets and disconnect all cables that are connected to the computer.
- 2 Remove the computer cover. For details, see [Removing the computer cover](#).
- 3 Replace the storage drive bracket.

📄 Note

Carefully handle the storage drive bracket to avoid breaking the front Wi-Fi antenna cable.

• Type1

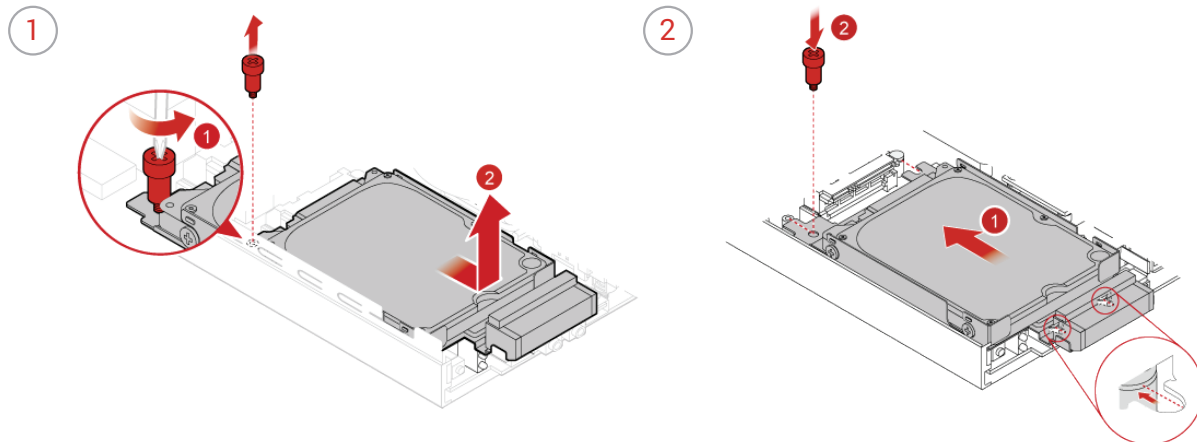

• Type2

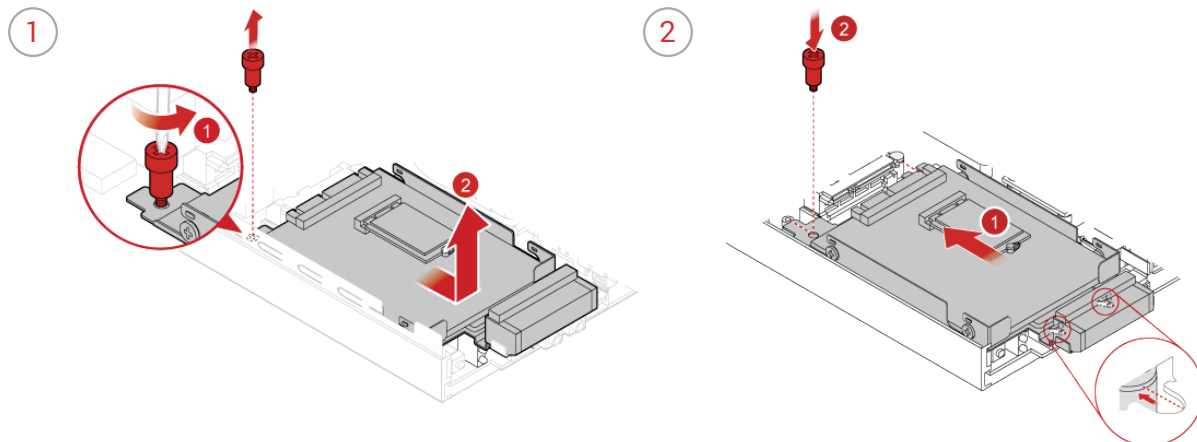

- 4 Reinstall the computer cover and reconnect the cables. For details, see [Completing the parts replacement](#).

Replacing the 2.5-inch storage drive



Attention

Do not open your computer or attempt any repairs before reading the *Important Product Information Guide*.

- 1 Remove any media from the drives and turn off all connected devices and the computer. Then, disconnect all power cords from electrical outlets and disconnect all cables that are connected to the computer.
- 2 Remove the computer cover. For details, see [Removing the computer cover](#).
- 3 Remove the storage drive bracket. For details, see [Replacing the storage drive bracket](#).
- 4 Replace the 2.5-inch storage drive.

1

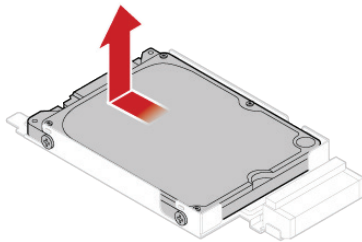

2

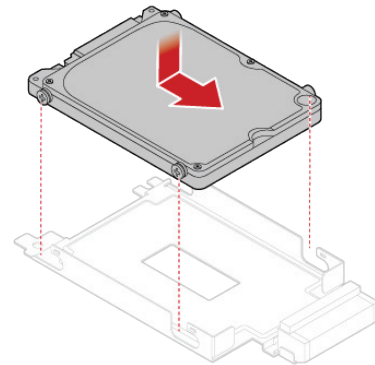

- 5 Reinstall the removed parts and computer cover, and then reconnect the cables. For details, see [Completing the parts replacement](#).

Replacing the M.2 storage drive

Attention

Do not open your computer or attempt any repairs before reading the *Important Product Information Guide*.

- 1 Remove any media from the drives and turn off all connected devices and the computer. Then, disconnect all power cords from electrical outlets and disconnect all cables that are connected to the computer.
- 2 Remove the computer cover. For details, see [Removing the computer cover](#).
- 3 Remove the storage drive bracket. For details, see [Replacing the 2.5-inch storage drive](#).
- 4 Replace the M.2 storage drive.

• Type1

1

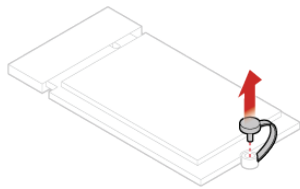

2

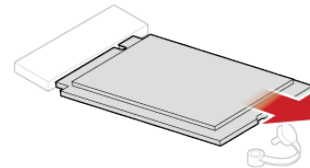

3

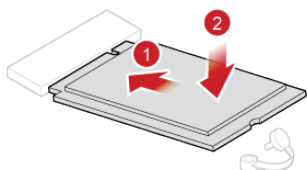

4

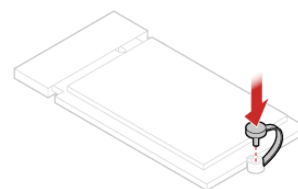

• Type2

1

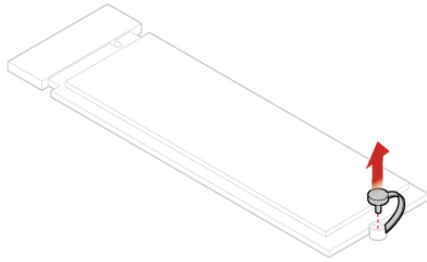

2

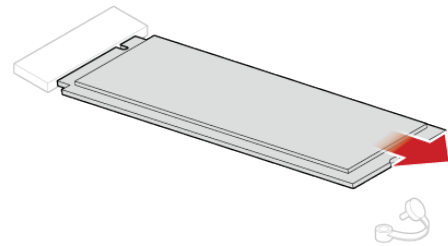

3

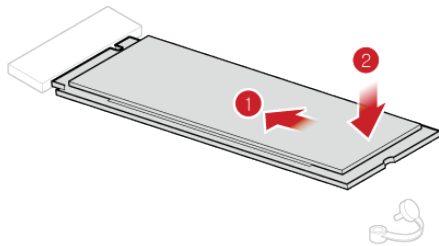

4

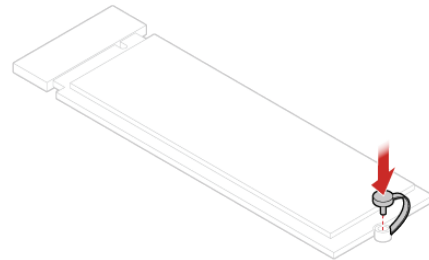

5 Reinstall the removed parts and computer cover, and then reconnect the cables. For details, see **Completing the parts replacement.**

Replacing the memory module



Attention

Do not open your computer or attempt any repairs before reading the *Important Product Information Guide*.

If your computer supports one memory module, install the module into the DIMM 1 slot. If your computer supports two memory modules, install one memory module into the DIMM 1 slot first and then install the other into the DIMM 2 slot.

- 1 Remove any media from the drives and turn off all connected devices and the computer. Then, disconnect all power cords from electrical outlets and disconnect all cables that are connected to the computer.
- 2 Remove the computer cover. For details, see [Removing the computer cover](#).
- 3 Remove the storage drive bracket. For details, see [Replacing the 2.5-inch storage drive](#).
- 4 Replace the memory module.

1

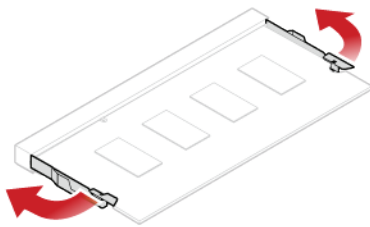

2

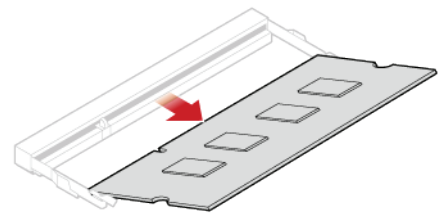

3

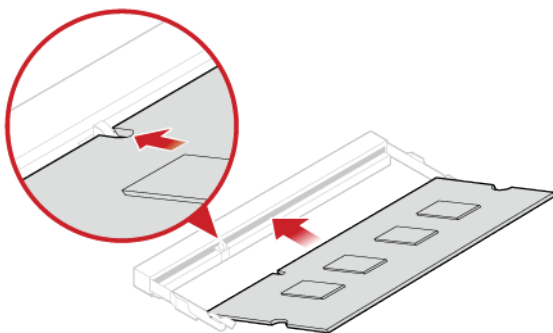

4

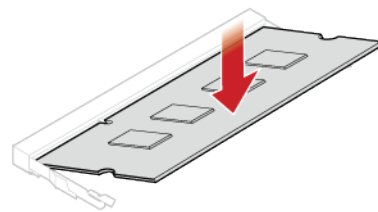

- 5 Reinstall the removed parts and computer cover, and then reconnect the cables. For details, see [Completing the parts replacement](#).

Replacing the coin-cell battery



Attention

Do not open your computer or attempt any repairs before reading the *Important Product Information Guide*.

Your computer has a special type of memory that maintains the date, time, and settings for built-in features, such as parallel connector assignments (configurations). A coin-cell battery keeps this information active when you turn off the computer.

The coin-cell battery normally requires no charging or maintenance throughout its life; however, no coin-cell battery lasts forever. If the coin-cell battery fails, the date, time, and configuration information (including passwords) are lost. An error message is displayed when you turn on the computer.

To replace the coin-cell battery,

1 Remove any media from the drives and turn off all connected devices and the computer. Then, disconnect all power cords from electrical outlets and disconnect all cables that are connected to the computer.

2 Remove the computer cover. For details, see [Removing the computer cover](#).

3 Remove the storage drive bracket. For details, see [Replacing the 2.5-inch storage drive](#).

4 Replace the coin-cell battery.

1

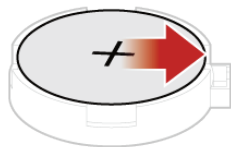

2

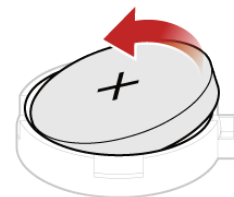

3

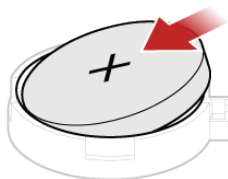

4

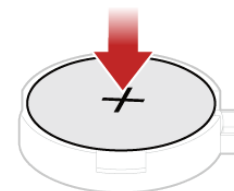

5 Reinstall the removed parts and computer cover, and then reconnect the cables. For details, see [Completing the parts replacement](#).

To dispose of the coin-cell battery, refer to the “Lithium coin-cell battery notice” topic in the **Safety and Warranty Guide**.

Replacing the Wi-Fi card



Attention

Do not open your computer or attempt any repairs before reading the *Important Product Information Guide*.



Note

The locations of Wi-Fi antenna connectors might vary.

- 1 Remove any media from the drives and turn off all connected devices and the computer. Then, disconnect all power cords from electrical outlets and disconnect all cables that are connected to the computer.
- 2 Remove the computer cover. For details, see [Removing the computer cover](#).
- 3 Remove the storage drive bracket. For details, see [Replacing the 2.5-inch storage drive](#).
- 4 Remove the Wi-Fi card shield.
 - Type 1

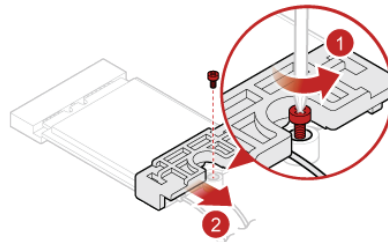

- Type 2

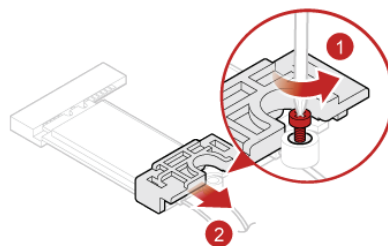

5 Replace the Wi-Fi card.

- Type 1

1

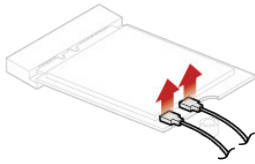

2

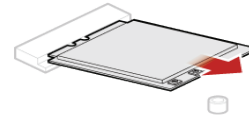

3

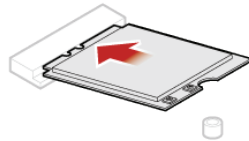

4



- Type 2

1

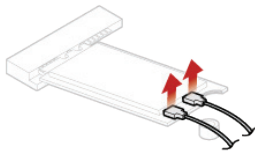

2

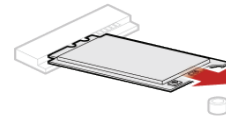

3

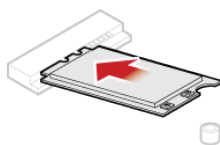

4

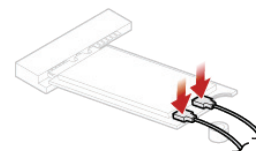

6 Reinstall the Wi-Fi card shield.

- Type 1

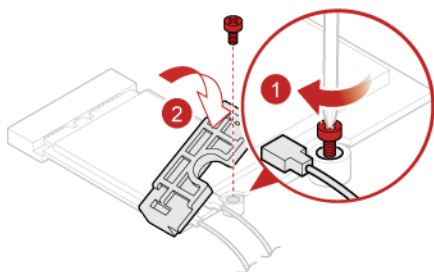

- Type 2

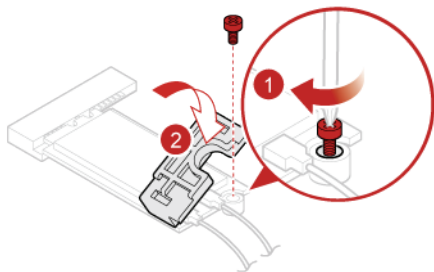

7 Reinstall the removed parts and computer cover, and then reconnect the cables. For details, see [Completing the parts replacement](#).

Replacing the wireless mouse



Note

The wireless mouse is available only on some models.

- 1 Remove any media from the drives and turn off all connected devices and the computer. Then, disconnect all power cords from electrical outlets and disconnect all cables that are connected to the computer.
- 2 Disconnect the USB dongle from your computer. Then, take away your failing wireless mouse.
- 3 Remove the new wireless mouse from the package.
- 4 Replace the wireless mouse.

1

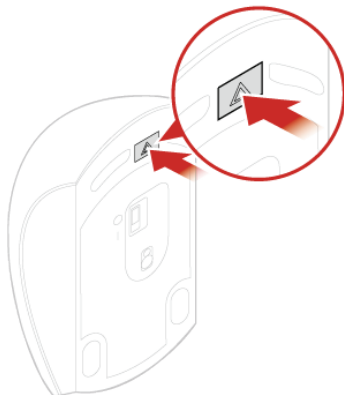

2

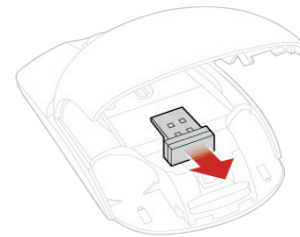

3

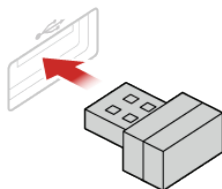

4

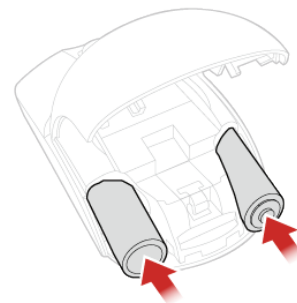

5

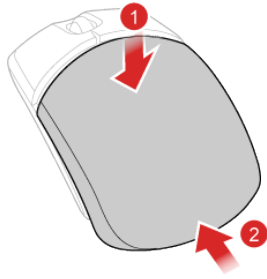

6

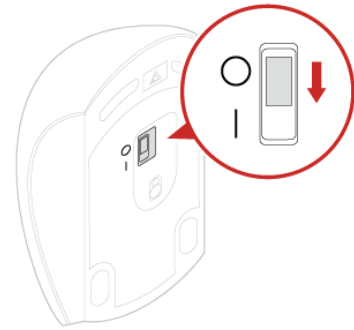

 **Note**

- The green LED indicates that the mouse is ready for use.
- The flashing amber LED indicates a low battery power level.
- Push the power switch to the off position when you are not using the mouse to extend the battery life.
- After disconnecting the USB dongle from your computer, store it in the wireless mouse compartment or in the wireless keyboard compartment.

Replacing the wireless keyboard



Note

The wireless keyboard is available only on some models.

- 1 Remove any media from the drives and turn off all connected devices and the computer. Then, disconnect all power cords from electrical outlets and disconnect all cables that are connected to the computer.
- 2 Remove your failing wireless keyboard.
- 3 Take out the new wireless keyboard from the package.
- 4 Open the battery compartment cover, and install two AAA batteries according to the polarity indicators.

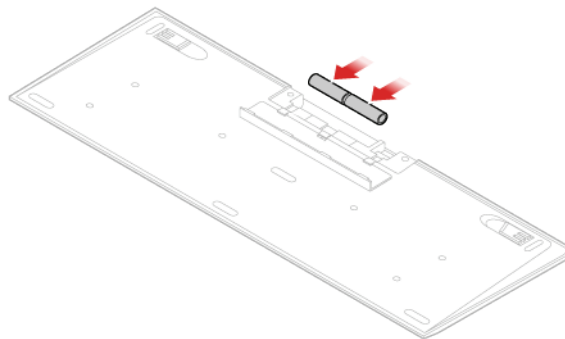

- 5 Take away the USB dongle from the keyboard compartment or from the wireless mouse compartment and connect it to an available USB connector on the computer.
- 6 Close the compartment cover. The keyboard is ready for use.

Completing the parts replacement



Attention

Do not open your computer or attempt any repairs before reading the *Important Product Information Guide*.

After completing the installation or replacement for all parts, reinstall the computer cover and reconnect the cables.

To reinstall the computer cover and reconnect the cables to your computer, do the following:

- 1 Ensure that all components have been reassembled correctly and that no tools or loose screws are left inside your computer.
- 2 Ensure that the cables are routed correctly before reinstalling the computer cover. Keep cables clear of the hinges and sides of the computer chassis to avoid interference when reinstalling the computer cover.
- 3 Install the computer cover.

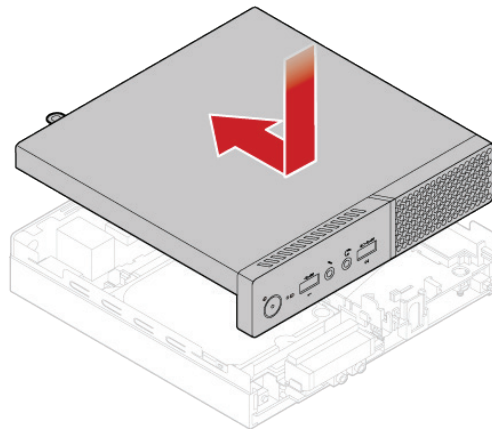

- 4 Install the screw to secure the computer cover.
- 5 If a locking device is available, use it to lock the computer.
- 6 Reconnect the external cables and power cords to the corresponding connectors on the computer.

Replacing field-replaceable units (FRUs)

Before replacing FRUs

Before replacing an FRU (Field Replaceable Unit), read the following:

- **Only certified and trained personnel can service the computer.**
- **Before replacing an FRU, read the entire section on replacing the part.**
- **Be extremely careful during writing operations such as copying, saving, or formatting.**
The sequence of the drives in the computer that you are servicing might have been altered. If you select an incorrect drive, data or programs might be overwritten.
- **Replace an FRU only with another FRU of the correct model.**
When you replace an FRU, ensure that the model of the machine and the FRU part number are correct by referring to the website: <http://www.lenovo.com/serviceparts-lookup>
- **An FRU should not be replaced because of a single, unreproducible failure.**
Single failures can occur for a variety of reasons that have nothing to do with a hardware defect, such as cosmic radiation, electrostatic discharge, or software errors. Consider replacing an FRU only when a problem recurs. If you suspect that an FRU is defective, clear the error log and run the test again. If the error does not recur, do not replace the FRU.
- **Only replace a defective FRU.**

To identify the FRU type of a computer component, see [CRUs and FRUs locations](#).



Attention

Do not open your computer or attempt any repairs before reading the *Important Product Information Guide*.

Click an image to replace and check brief procedures.

Internal speaker holder >

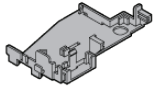

Heat Sink >

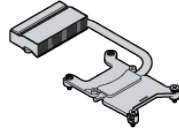

Microprocessor >

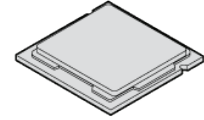

Front Wi-Fi antenna >

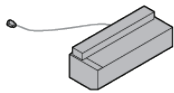

Rear Wi-Fi antenna >

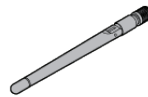

System board >

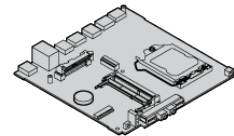

Note

To replace a component that is not in the list above, contact a Lenovo service technician. The support phone numbers are available at <http://www.lenovo.com/support/phone>.

Replacing the internal speaker holder



Attention

Do not open your computer or attempt any repairs before reading the *Important Product Information Guide*.

- 1 Remove any media from the drives and turn off all connected devices and the computer. Then, disconnect all power cords from electrical outlets and disconnect all cables that are connected to the computer.
- 2 Remove the computer cover. For details, see [Removing the computer cover](#).
- 3 Record the routing and connection of the internal speaker cable, and then disconnect the cable from the system board.
- 4 Remove the internal speaker. For details, see [Replacing the internal speaker](#).
- 5 Replace the internal speaker holder.

1

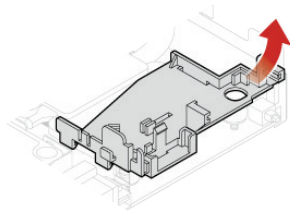

2

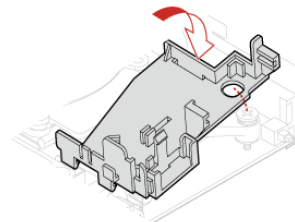

- 6 Connect the cable of the internal speaker to the internal speaker connector on the system board.
- 7 Reinstall the removed parts and computer cover, and then reconnect the cables. For details, see [Completing the parts replacement](#).

Replacing the heat sink



Attention

Do not open your computer or attempt any repairs before reading the *Important Product Information Guide*.



Caution

The heat sink might be very hot. Before you open the computer cover, turn off the computer and wait several minutes until the computer is cool.

- 1 Remove any media from the drives and turn off all connected devices and the computer. Then, disconnect all power cords from electrical outlets and disconnect all cables that are connected to the computer.
- 2 Remove the computer cover. For details, see [Removing the computer cover](#).
- 3 Remove the system fan. For details, see [Replacing the system fan](#).
- 4 Remove the internal speaker. For details, see [Replacing the internal speaker](#).
- 5 Remove the internal speaker holder. For details, see [Replacing the internal speaker holder](#).
- 6 Replace the heat sink.

1

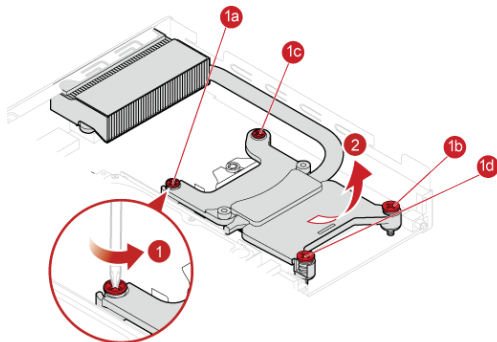

2

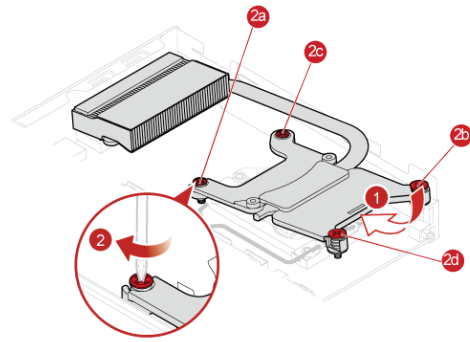

- 7 Reinstall the removed parts and computer cover, and then reconnect the cables. For details, see [Completing the parts replacement](#).

Replacing the microprocessor



Attention

Do not open your computer or attempt any repairs before reading the *Important Product Information Guide*.



Caution

The heat sink and microprocessor might be very hot. Before you open the computer cover, turn off the computer and wait several minutes until the computer is cool.

- 1 Remove any media from the drives and turn off all connected devices and the computer. Then, disconnect all power cords from electrical outlets and disconnect all cables that are connected to the computer.
- 2 Remove the computer cover. For details, see [Replacing the computer cover](#).
- 3 Remove the system fan. For details, see [Replacing the system fan](#).
- 4 Remove the internal speaker. For details, see [Replacing the internal speaker](#).
- 5 Remove the internal speaker holder. For details, see [Replacing the internal speaker holder](#).
- 6 Remove the heat sink. For details, see [Replacing the heat sink](#).
- 7 Disconnect all cables connected to the system board.

8 Replace the microprocessor.



Note

- Your microprocessor and socket might look different from the one illustrated.
- Touch only the edges of the microprocessor. Do not touch the gold contacts on the bottom.
- Do not drop anything onto the microprocessor socket while it is exposed. The socket pins must be kept as clean as possible.

1

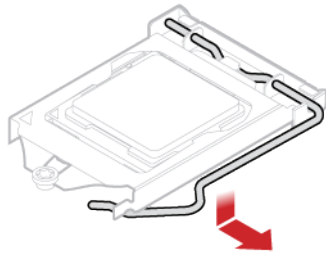

2

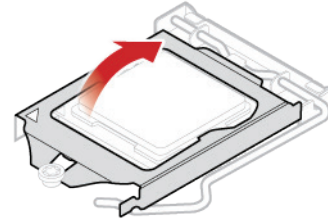

3

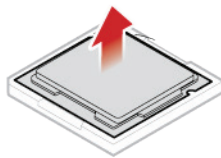

4

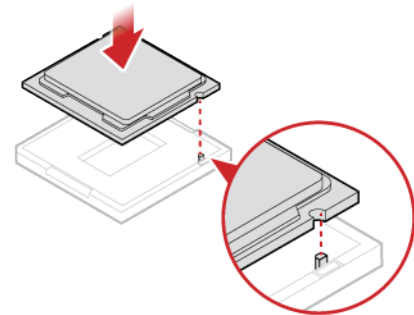

5

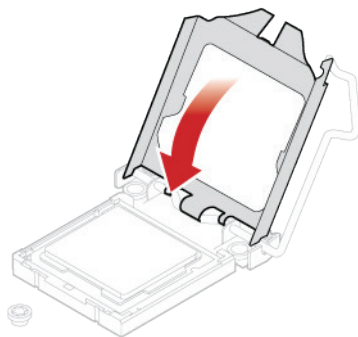

6

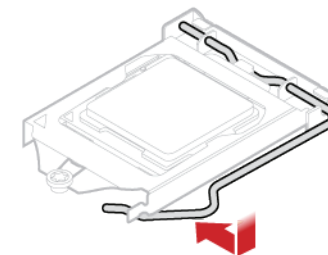

9 Reconnect all cables that were disconnected from the system board. For details, see [System board](#).

10 Reinstall the removed parts and computer cover, and then reconnect the cables. For details, see [Completing the parts replacement](#).

Replacing the front Wi-Fi antenna

⚠ Attention

Do not open your computer or attempt any repairs before reading the *Important Product Information Guide*.

- 1 Remove any media from the drives and turn off all connected devices and the computer. Then, disconnect all power cords from electrical outlets and disconnect all cables that are connected to the computer.
- 2 Remove the computer cover. For details, see [Removing the computer cover](#).
- 3 Remove the storage drive bracket. For details, see [Replacing the 2.5-inch storage drive](#).
- 4 Remove the Wi-Fi card shield. For details, see [Replacing the Wi-Fi card](#).
- 5 Disconnect the front antenna cable from the Wi-Fi card.
- 6 Replace the front Wi-Fi antenna.

1

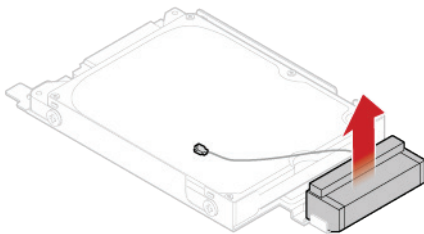

2

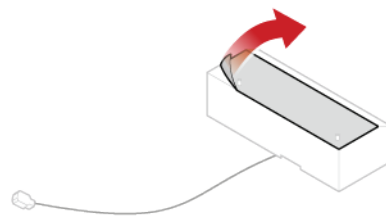

3

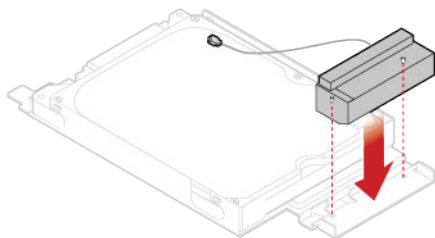

- 7 Connect the front antenna cable to the Wi-Fi card.
- 8 Reinstall the removed parts and computer cover, and then reconnect the cables. For details, see [Completing the parts replacement](#).

Replacing the rear Wi-Fi antenna



Attention

Do not open your computer or attempt any repairs before reading the *Important Product Information Guide*.

- 1 Remove any media from the drives and turn off all connected devices and the computer. Then, disconnect all power cords from electrical outlets and disconnect all cables that are connected to the computer.
- 2 Straighten the rear Wi-Fi antenna so that it can be more easily twisted.
- 3 Replace the rear Wi-Fi antenna.

1

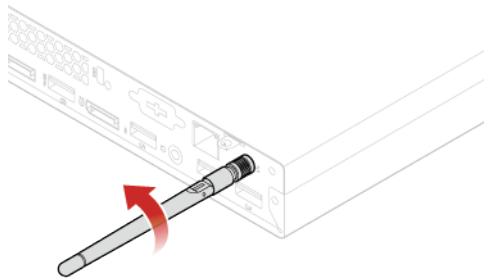

2

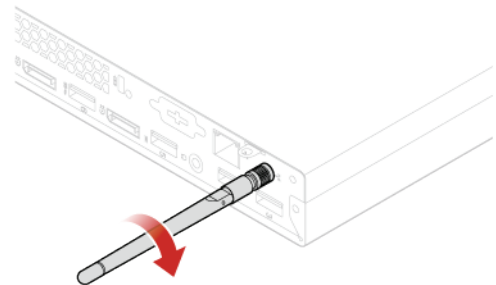

- 4 Adjust the angle of the rear antenna to lower the risk of breaking the antenna by accident.

Replacing the system board



Attention

Do not open your computer or attempt any repairs before reading the *Important Product Information Guide*.

- 1 Remove any media from the drives and turn off all connected devices and the computer. Then, disconnect all power cords from electrical outlets and disconnect all cables that are connected to the computer.
- 2 Remove the computer cover. For details, see [Removing the computer cover](#).
- 3 Remove the system fan. For details, see [Replacing the system fan](#).
- 4 Remove the internal speaker. For details, see [Replacing the internal speaker](#).
- 5 Remove the internal speaker holder. For details, see [Replacing the internal speaker holder](#).
- 6 Remove the heat sink. For details, see [Replacing the heat sink](#).
- 7 Remove the storage drive bracket. For details, see [Replacing the 2.5-inch storage drive](#).
- 8 Remove the M.2 storage drive. For details, see [Replacing the M.2 storage drive](#).
- 9 Remove the memory module. For details, see [Replacing the memory module](#).
- 10 Remove the Wi-Fi card. For details, see [Replacing the Wi-Fi card](#).
- 11 Remove the microprocessor. For details, see [Replacing the microprocessor](#).
- 12 Record the cable routing and cable connections, and then disconnect all cables from the system board.

13 Replace the system board.



Note

Carefully handle the system board by its edges.

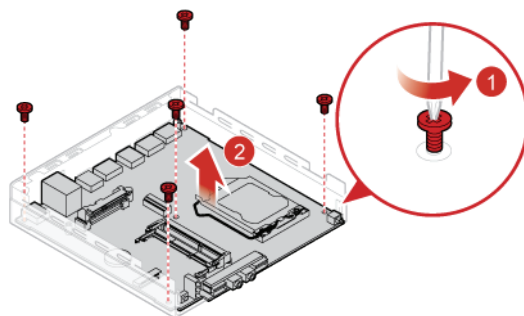

14 Route all the cables that you disconnected from the failing system board, and then reconnect the cables to the new system board. For details, see [System board](#).

15 Reinstall the removed parts and computer cover, and then reconnect the cables. For details, see [Completing the parts replacement](#).

Notices & Trademarks

Notices

Lenovo may not offer the products, services, or features discussed in this document in all countries. Consult your local Lenovo representative for information on the products and services currently available in your area. Any reference to a Lenovo product, program, or service is not intended to state or imply that only that Lenovo product, program, or service may be used. Any functionally equivalent product, program, or service that does not infringe any Lenovo intellectual property right may be used instead. However, it is the user's responsibility to evaluate and verify the operation of any other product, program, or service.

Lenovo may have patents or pending patent applications covering subject matter described in this document. The furnishing of this document does not give you any license to these patents. You can send license inquiries, in writing, to:

Lenovo (United States), Inc.
1009 Think Place - Building One
Morrisville, NC 27560
U.S.A.
Attention: Lenovo Director of Licensing

LENOVO PROVIDES THIS PUBLICATION AS IS WITHOUT WARRANTY OF ANY KIND, EITHER EXPRESS OR IMPLIED, INCLUDING, BUT NOT LIMITED TO, THE IMPLIED WARRANTIES OF NON-INFRINGEMENT, MERCHANTABILITY OR FITNESS FOR A PARTICULAR PURPOSE. Some jurisdictions do not allow disclaimer of express or implied warranties in certain transactions, therefore, this statement may not apply to you.

This information could include technical inaccuracies or typographical errors. Changes are periodically made to the information herein; these changes will be incorporated in new editions of the publication. Lenovo may make improvements and/or changes in the product(s) and/or the program(s) described in this publication at any time without notice.

The products described in this document are not intended for use in implantation or other life support applications where malfunction may result in injury or death to persons. The information contained in this document does not affect or change Lenovo product specifications or warranties. Nothing in this document shall operate as an express or implied license or indemnity under the intellectual property rights of Lenovo or third parties. All information contained in this document was obtained in specific environments and is presented as an illustration. The result obtained in other operating environments may vary.

Lenovo may use or distribute any of the information you supply in any way it believes appropriate without incurring any obligation to you.

Any references in this publication to non-Lenovo Web sites are provided for convenience only and do not in any manner serve as an endorsement of those Web sites. The materials at those Web sites are not part of the materials for this Lenovo product, and use of those Web sites is at your own risk.

Any performance data contained herein was determined in a controlled environment. Therefore, the result obtained in other operating environments may vary significantly. Some measurements may have been made on development-level systems and there is no guarantee that these measurements will be the same on generally available systems. Furthermore, some measurements may have been estimated through extrapolation. Actual results may vary. Users of this document should verify the applicable data for their specific environment.

Trademarks

The following terms are trademarks of Lenovo in the United States, other countries, or both:

Lenovo
The Lenovo logo
ThinkCentre
ThinkCentre logo

DisplayPort and VESA are trademarks of the Video Electronics Standards Association.

Other company, product, or service names may be trademarks or service marks of others.