



Cat. No. HCCS7



## WALL MOUNTED CONTROLLER

w/Multiple Addressing

Cat. Nos.

- HCC2D
- HCC3D
- HCC4A
- HCC4D
- HCCS7

Rated: 120VAC, 60 Hz

## INSTALLATION INSTRUCTIONS



PK-93028-10-00-0B

### LIMITED TWO YEAR WARRANTY AND EXCLUSIONS

Leviton warrants to the original consumer purchaser and not for the benefit of anyone else that this product at the time of its sale by Leviton is free of defects in materials and workmanship under normal and proper use for two years from the purchase date. Leviton's only obligation is to correct such defects by repair or replacement, at its option, if within such two year period the product is returned prepaid, with proof of purchase date, and a description of the problem to **Leviton Manufacturing Co., Inc., Att: Quality Assurance Department, 59-25 Little Neck Parkway, Little Neck, New York 11362-2591**. This warranty excludes and there is disclaimed liability for labor for removal of this product or reinstallation. This warranty is void if this product is installed improperly or in an improper environment, overloaded, misused, opened, abused, or altered in any manner, or is not used under normal operating conditions or not in accordance with any labels or instructions. There are no other or implied warranties of any kind, including merchantability and fitness of a particular purpose, but if any implied warranty is required by the applicable jurisdiction, the duration of any such implied warranty, including merchantability and fitness for a particular purpose, is limited to two years. Leviton is not liable for incidental, indirect, special, or consequential damages, including without limitation, damage to, or loss of use of, any equipment, lost sales or profits or delay or failure to perform this warranty obligation. The remedies provided herein are the exclusive remedies under this warranty, whether based on contract, tort or otherwise.

For Technical Assistance Call:  
**1-800-824-3005**  
[www.leviton.com](http://www.leviton.com)



PK-93028-10-00-0B

FEATURES			
• Leviton's Decora® Style design	• Universal design works with 1 and 2-Way Receivers	• Memory retained after Power Interruption	• Color conversion available
INTRODUCTION			
Leviton Residential Powerline Carrier Components are designed to provide the greatest signal integrity and noise immunity possible. However, in some environments intense electrical noise can cause interference with the signal. Leviton has developed hardware and techniques for overcoming this interference when properly applied.			
<b>LEVITON'S DHC DEVICES FEATURE INTELLISENSE, THE RIGHT TYPE OF AUTOMATIC GAIN CONTROL (AGC)</b>			
Leviton DHC devices use Intellisense, a special gated-type of AGC, to help eliminate noise problems (refer Figure 1). This circuit feature is ideal for powerline carrier systems because it only operates during the signal window when receivers listen for command signals. Noise levels in the signal window are never as high as they are during other portions of the AC power curve. Therefore, Leviton's Intellisense gated AGC will desensitize a receiver to noise signals with only a minimal reduction in command signal sensitivity. The result: Problems from noise interference are dramatically reduced without affecting overall system performance. It is the responsibility of the specifier/installer to test for signal strength and the presence of noise using Leviton test equipment, Cat. Nos. 6385 (Signal Test Transmitter) and 6386 (Signal Strength Indicator), and to properly apply signal coupling and noise reduction equipment according to the guidelines provided in the Decora® Home Controls (DHC) Technical Manual and the DHC Troubleshooting Guide.			
Leviton specifically denies any warranty of performance, stated or implied, where electrical noise interference exists at the time of installation, or subsequent to installation by the addition of noise-producing devices or equipment, or where these components have been installed for non-residential applications. Installation of a Repeater/Coupler is recommended in all DHC systems. DHC Components are for residential use only. Installation for any other application voids any warranty, stated or implied.			
DESCRIPTION			
<b>Wall box Transmitter</b>			
The HCCxx is a signal transmitter that works in conjunction with DHC receivers. The Wall-Mounted DHC Transmitter is designed to provide manual control of loads from one or more locations in a home over standard 60Hz 120V wiring.			
The HCCxx Transmitter incorporates Leviton's exclusive Intellisense™ Automatic Gain Control (AGC) circuitry to deliver clearer and stronger line signals without affecting signals simultaneously on the line from other transmitters. The resulting performance reliability exceeds that of any other powerline carrier home automation product line available today.			
FCC COMPLIANCE STATEMENT			
This equipment has been tested and found to comply with the limits for a Class B digital device, pursuant to Part 15 of the FCC rules. These limits are designed to provide reasonable protection against harmful interference in a residential installation. This equipment generates, uses, and can radiate radio frequency energy and, if not installed and used in accordance with the instructions, may cause harmful interference to radio communications. However, there is no guarantee that interference will not occur in a particular installation. If this equipment does cause harmful interference to radio or television reception, which can be determined by turning the equipment OFF and ON, the user is encouraged to try to correct the interference by one or more of the following measures:			
<ul style="list-style-type: none"> <li>• Reorient or relocate the receiving antenna.</li> <li>• Increase the separation between the equipment and the receiver.</li> <li>• Connect the equipment into an outlet on a circuit different from that to which the receiver is connected.</li> <li>• Consult the dealer or an experienced radio/tv Technician for help.</li> </ul>			
SPECIFICATIONS			
Rating:	120VAC, 60Hz		
Max. Controllers on 1 circuit:	4		
Power Consumption:	3W		
HCCxx CONFIGURATIONS			
HCC2D:	ON/OFF for 2 addresses in sequence, plus DIM/BRIGHTEN of each address (6 buttons)		
HCC3D:	ON/OFF for 3 addresses in sequence, plus DIM/BRIGHTEN of each address (8 buttons)		
HCC4A:	ON/OFF for 3 addresses in sequence, plus DIM/BRIGHTEN of each address and ALL ON/OFF control of addresses within the same letter code (10 buttons)		
HCC4D:	ON/OFF for 4 addresses in sequence, plus DIM/BRIGHTEN of each address (10 buttons)		
HCCS7:	7 scenes plus DIM/BRIGHTEN on 12 sequential pre-selected addresses		
<b>NOTE:</b> Cat. No. HCCxx Wall Mounted Controller is not intended to replace standard wall switches. The Controller requires one HOT (BLACK) and one NEUTRAL (WHITE) conductor for proper operation. Incorrect installation will void warranty.			
INSTALLATION INSTRUCTIONS			
<b>WARNING:</b> TO BE INSTALLED AND/OR USED IN ACCORDANCE WITH APPROPRIATE ELECTRICAL CODES AND REGULATIONS.			
<b>WARNING:</b> IF YOU ARE NOT SURE ABOUT ANY PART OF THESE INSTRUCTIONS, CONSULT A QUALIFIED ELECTRICIAN.			
<b>WARNING:</b> INSTALL TO CONTROL SCENE DIMMERS AND APPLICABLE DHC RECEIVERS ONLY. <b>DO NOT</b> INSTALL TO CONTROL <b>ANY</b> LOAD DIRECTLY.			
<b>CAUTION:</b> USE THIS DEVICE ONLY WITH COPPER OR COPPER CLAD WIRE. WITH ALUMINUM WIRE USE ONLY DEVICES MARKED CO/ALR OR CU/AL.			
<b>TO INSTALL:</b>			
1. <b>WARNING:</b> TO AVOID FIRE, SHOCK, OR DEATH; TURN OFF POWER AT CIRCUIT BREAKER OR FUSE AND TEST THAT POWER IS OFF BEFORE WIRING!			
2. Remove approximately 3/4" (1.9 cm) of insulation from circuit conductors.			
3. If using a standard Decora® wallplate, remove "A" tabs from strap (refer Figure 2). If using a Decora® Plus Screwless wallplate, leave tabs intact.			
4. Connect wires per WIRING DIAGRAM as follows: BLACK (Hot) wire to BLACK lead of device, and WHITE (Neutral) to White lead of device. Twist strands of each lead tightly together and, with circuit conductor, push firmly into appropriate wire connector. Screw connector on clockwise making sure that no bare wire shows below the connector. Secure each wire connector with electrical tape.			
5. Mount Cat. No. HCCxx in wall box using the screws provided.			
<b>NOTE:</b> Ensure that the "PROGRAM BUTTON" is located at the bottom of the device when mounting (refer to Indicator Position Diagram).			
6. Remove Front Face of Cat. No. HCCxx (refer to Color Conversion Procedure) to access controls for programming.			
7. Restore power at circuit breaker or fuse. Set the address using the "ADDRESS PROGRAMMING" sequence below.			
8. Replace Front Face (see Color Conversion Procedure).			
9. Attach the supplied programming instruction and code table labels to back of wallplate. Replace wallplate. <b>INSTALLATION IS COMPLETE.</b>			
ADDRESS PROGRAMMING			
The system communicates via a "preset code" set on transmitters (this device), and receivers (dimmers and switches). The code consists of a letter code (A, B, C, ..., P) and a number code (1, 2, 3, ..., 16) (refer to Indicator Position Diagram). The unit must be set (programmed) to allow it to communicate with devices in the Home Control System. This is accomplished by setting the controller's transmit code to correspond with dimmers and switches in the system it is installed in. Program as follows:			
1. Determine what switches and dimmers you want to control.			
2. The HCCxx multi-button controller will control devices set to the same code as itself. The first (most upper) ON/OFF buttons will control a device set to its code (i.e., "A5"). The next lower row and consecutive row of buttons will control devices with sequential code settings (i.e., 1 <sup>st</sup> row "A5" (device code), 2 <sup>nd</sup> row "A6", 3 <sup>rd</sup> and 4 <sup>th</sup> row (if equipped), "A7" and "A8").			

Figure 1 - Intellisense AGC

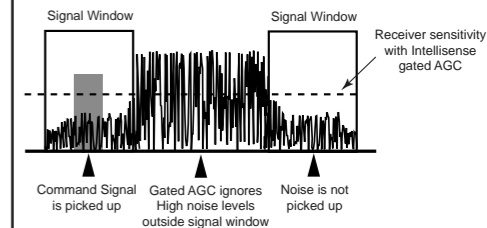

Figure 2 - Control Functions (Cat. No. HCC4D depicted)

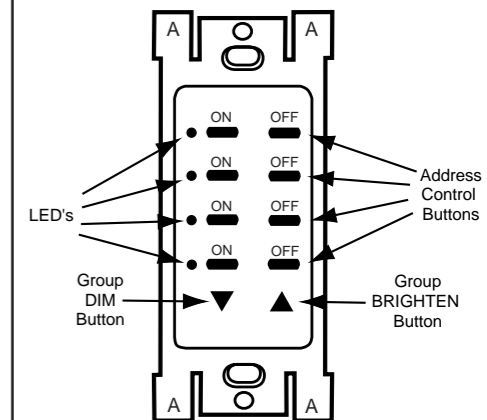
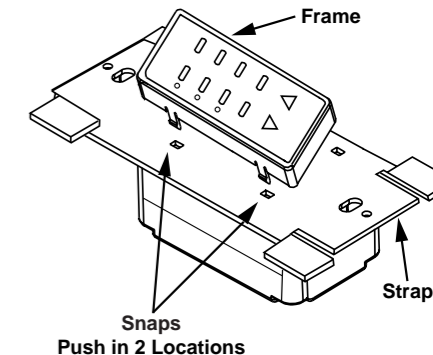

Figure 3 - Switch Plate Removal (Color Conversion and Programming)



**PERFECT PERFORMANCE CHECKLIST**

If the Cat. No. HCCxx Controller appears to be functioning improperly proceed with the following steps:

1. Confirm that the Controller is wired exactly as shown in the wiring diagram.
2. Confirm that the receiver module is being supplied from a 120V, 60Hz AC source ONLY.
3. Confirm that the load being controlled is in proper working order. Local switch, ON (check for burned-out bulbs, etc.).
4. Confirm that the Controller is powered and is set to transmit commands to the same letter and number code as on receiver modules.
5. Confirm that the Cat. No. HCCxx keypad is installed properly.
  - NOTE:** If the Controller still does not operate properly after following steps 1-5, proceed with diagnostic steps 6 and 7.
6. Set the Controller to transmit address P1. Using a Cat No. 6386 Signal Strength Indicator plugged in on the same branch circuit as the Controller, confirm that the Controller is transmitting a minimum reading of 2 volts of command signal at the HI-RANGE setting. If the signal strength is less than 2 volts, have the Controller checked.
7. Check for adequate command signal at the Cat. No. HCCxx location as follows:
  - A. Plug the Cat. No. 6385 Signal Test Transmitter into a receptacle on the same circuit breaker as the Controller.
  - B. Using the Cat. No. 6386 Signal Strength Indicator at the HCCxx location, check the command signal amplitude. Signal strength must be 100mV minimum. If there is less than 100mV of signal present, it may be necessary to couple both legs of the 120/240 Volt power service at the entrance panel using a Leviton Repeater/Coupler.
  - C. If the Yellow ERROR CONDITION indicator is lit, there is electrical "noise" present on the AC line which is interfering with proper module operation. The source of the noise must be identified and either filtered out or eliminated (**See Technical Manual**).
8. Confirm that you have a recent version of the DHC System Coupler/Repeater. To do this, follow steps 1-3 in the Scene Programming section. If the LED's continue to flash after a scene button is pressed in step 3, you must upgrade your DHC System. A Repeater/Coupler is recommended in all DHC systems for maximum signal.
9. The Leviton Technical Manual covers common DHC problems and system issues in more detail.

3. To set the code on the controller, perform the following (**refer to Indicator Position Diagram**):

- a) Remove wallplate and front face of device (**refer to Color Conversion Procedure**).
- b) You will see rows of BLACK buttons with a protruding plastic LED to its left. The left hand row of four buttons is used to set the Unit Codes (numbers 1-16). The right hand row of four buttons is used to set the House Codes (letters A-P).
- c) Press the recessed "PROGRAM BUTTON" once. The LED's will flash approximately every 2 to 5 seconds.
- d) **To set Unit Code:** Determine code setting required (i.e., L7, Unit Code is 7). Using matrix chart (**refer to Indicator Position Diagram**), determine which switches should be turned ON. Press the switch next to corresponding LED position to turn that LED ON, (i.e., "7", press switches 2<sup>nd</sup> and 3<sup>rd</sup> down from top to turn ON, LED's next to them will illuminate and not flash).
- e) **To set House Code:** Determine code setting required (i.e., L7, House Code is L). Using matrix chart (**refer to Indicator Position Diagram**), determine which switches should be turned ON; press switch next to corresponding LED position to turn that LED ON, (i.e., "7", press switches 1 (top right), 2<sup>nd</sup> and 4<sup>th</sup> down from top to turn ON, LED's next to them will illuminate and not flash).
- f) Press "PROGRAM BUTTON" again. LED's will stop flashing. Unit is now programmed to L7.
- g) To change or check set codes, press PROGRAM BUTTON again. LED's will illuminate corresponding last set code. Repeat steps D through F if change is desired.
  - NOTE: Ensure that the "PROGRAM BUTTON" is pressed again after checking or changing programming to ensure unit is in operating mode.**
- i) Replace front face and wallplate. **Programming is complete.**

5. Set applicable Receiver code to correspond with the code of this Transmitter or code of suitable desired row (refer to Receiver Program Instructions).

**SCENE PROGRAMMING (Cat. No. HCCS7 ONLY)**

**NOTE:** Scenes may be set for devices set to the same code as transmitter and additional sequential 11 unit code (i.e., code set to A1 will permit scenes on devices to be set to A1-A12. If code "16" is reached before 12 sequential codes, it will start with 1, 2, 3 (i.e., code set to A15, cycling sequence is A15, A16, A1..A10).

**NOTE:** Scenes sent to all 16 codes simultaneously can only have 12 sequential addresses programmed/unprogrammed.

1. Press and hold the scene button you would like to program for approximately 5 seconds. All LED's will flash except for selected scene button. You are now in the programming mode.
2. At each local dimmer (Cat. No. HCM10 or HCM06) or switch (Cat. No. HCS10, non-dimmable), adjust lights to the desired level.
3. Press the selected scene button on the HCCS7. The LED next to the scene button will flash for approximately 5 seconds then stay ON. The scene is now programmed.
  - NOTE:** To erase a selected scene from the 12 sequential codes in memory, press the OFF button while in the Scene Programming mode.
4. Repeat steps 1 through 3 to program each additional scene until all of the scenes are set.
5. Press the SCENE BUTTON once to send the scene command to all units on the housecode.

**COLOR CONVERSION PROCEDURE**

The color of this device can be changed to suit your interior design requirements. Simply obtain a color conversion kit of the appropriate color from your Leviton distributor and proceed as follows (please note that the wallplate must be removed).

1. Select the color of the face you desire.
2. The frame has snaps on its sides. Using a small screwdriver, **gently** remove the frame from the strap (**refer Figure 3**).
3. Take the new frame and position it properly to the strap. Line up the plastic snaps with the square holes in the strap. Insert the snaps on one side of the frame into the strap.
4. Firmly press sideways and down to slip the other snaps into place. The frame snaps in with a audible click. Ensure that all four snaps are secure. Replace Decora® wallplate. **The color conversion is complete.**

**TO OPERATE (Cat. Nos. HCC2D, HCC3D, HCC4A and HCC4D ONLY)**

Pressing the top ON button will transmit an ON command for the preset address. Pressing the top OFF button will transmit an OFF command for the preset address. The next lower row of ON/OFF buttons will perform ON/OFF commands for the next sequential address of the one selected (i.e., first row A1, second row A2, third row A3).

The group DIM/BRIGHT buttons (arrows) will DIM or BRIGHTEN the last selected address. To DIM or BRIGHTEN another address, press the ON button for the desired address and then use the group DIM/BRIGHT control.

On the HCC4A, the bottom row OFF button will transmit the ALL ON/ALL OFF commands for all devices set to the same letter code (i.e., A). To adjust brightness level of **LAST** selected address, use DIM and BRIGHT arrows.

When transmitting an ON/ALL ON command, the LED will blink while the signal is being transmitted and will stay ON when the signal has completed the transmission. When transmitting an OFF/ALL OFF command, the LED will blink while the signal is being transmitted and turn OFF when the signal has completed the transmission. Pressing the BRIGHT or DIM button will cause the LED's on the face of the keypad to flash and will remain flashing until the button is released.

**NOTE:** When used with a 2-Way Receivers, the LED's will indicate the status of those devices (i.e., if the Dimmer/Switch is turned ON at it's source, the ON/OFF LED who's address corresponds to that device will turn ON/OFF to match).

**TO OPERATE (Cat. Nos. HCCS7 ONLY)**

Pressing the scene button will transmit a SCENE ON command. Pressing another scene button will change the lighting to that programmed scene. Pressing the "OFF" button will turn OFF the last selected scene. To adjust brightness level of last selected address, use DIM and BRIGHT arrows.

When transmitting a SCENE ON command, the LED will blink while the signal is being transmitted and will stay ON when the signal has completed the transmission. When transmitting an OFF command, the LED will blink while the signal is being transmitted and turn OFF when the signal has completed the transmission. When the DIM or BRIGHT arrow is pressed, all LED's will flash until the button is released.

**NOTE:** When used with a 2-Way Receivers, the Scene Dimmer will only indicate status when all devices are OFF.

**TESTING**

Press the keypad to confirm that the load or loads are turned ON and OFF within two seconds of signal transmission. If the Cat. No. HCCxx Controller appears to be functioning improperly or operates erratically, read the following paragraphs, then refer to the Perfect Performance Checklist.

The HCCxx series can switch multiple addresses from the same Controller. The top button transmits as per the letter/number code set on the Controller, and so on.

**Examples:**

1. A Cat. No. HCC4A set at A3: top button controls the A3 address, the next button down controls the A4 address, and so on.
2. A Cat. No. HCC4A set at B15: top button controls the B15 address, the next button down controls the B16 address, the next button down controls the B1 address, and the last button controls the B2 address.

An ALL ON/OFF button controls **ALL** DHC modules set to the same letter code as on the Cat. No. HCCxx Controller. ALL ON only turns ON lighting modules. ALL OFF turns OFF **ALL** modules set to the same letter code.

**Indicator Position Diagram ("L7" Address Programming Shown)**

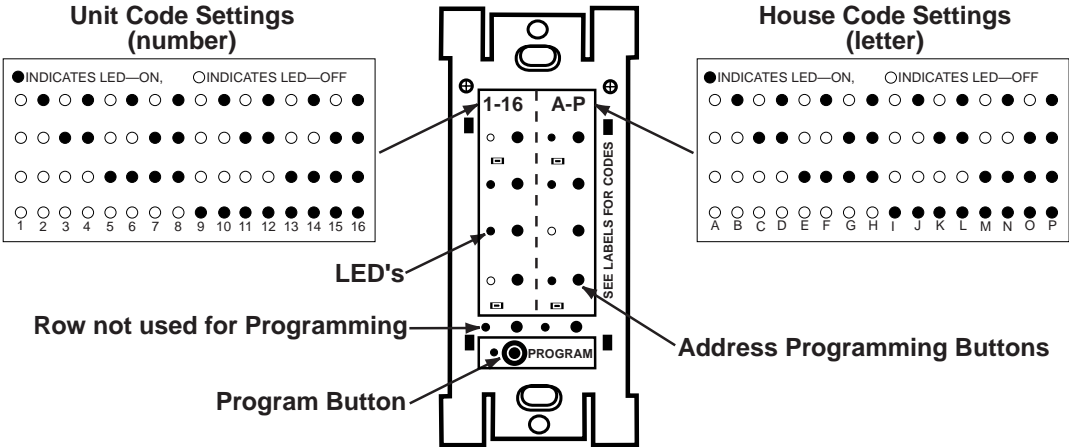

Cat. No. HCCxx

**Wiring Diagram**

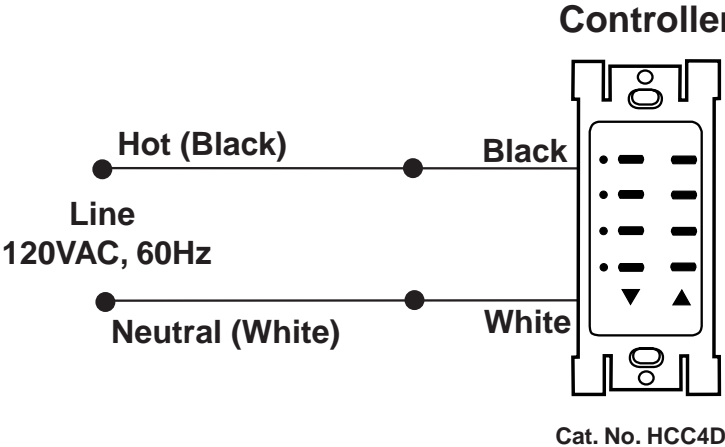

Cat. No. HCC4D