

WARNINGS AND CAUTIONS:

- To be installed and/or used in accordance with appropriate electrical codes and regulations.
- If you are unsure about any part of these instructions, consult a qualified electrician.

WARNINGS AND CAUTIONS:

- Save this instruction sheet. It contains important technical data along with testing and troubleshooting information which will be useful after installation is complete.

INTRODUCTION

Leviton's Vizia™ RF components are designed to communicate with each other via Radio Frequency (RF) to provide remote control of your lighting. Using RF technology allows Leviton to provide the greatest signal integrity possible. Each module in Leviton's Vizia™ RF component line is a Z-Wave™ enabled device. In a Z-Wave™ network, each device is designed to act as a router. These routers will re-transmit the RF signal from one device to another until the intended device is reached. This ensures that the signal is received by its intended device by routing the signal around obstacles and radio dead spots. The Plug-In Serial Interface Module is compatible with any Z-Wave™ enabled network, regardless of the manufacturer and can also be used with other devices displaying the Z-Wave™ logo.

CAUTION:

Remember to exercise good common sense when using the Timer features of your remote, especially when scheduling unattended devices. There can be some unexpected consequences if not used with care. For example, an empty coffee pot can be remotely turned on. If that should happen, your coffee pot could be damaged from overheating. If an electric heater is turned on by remote control while clothing is draped over it, a fire could result.

FEATURES

- RS232 - ASCII
- Scene capable
- Two way communication
- RF reliability
- Ease of installation – No new wiring
- Compatible with other Z-Wave™ enabled devices

NOTE: This product requires the use of third party software to function, along with a relatively high level of programming skill.

INSTALLING YOUR INTERFACE MODULE

NOTE: Use check boxes when Steps are completed.

Step 1 Attaching Serial-RS232 Cable or HAI Cable to Plug-In Serial Interface Module:

NOTE: In order to use your Vizia™ Plug-In Serial Interface Module in a Z-Wave™ network, it must be Included into the network using a Primary Programmer/Remote, such as Leviton's Cat. No., RZCPG. Before Including your module, please refer to the Primary Programmer/Remote instruction sheet for complete information. Refer to Step 3 for further details.

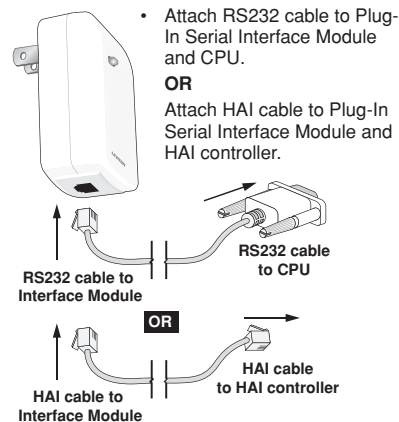

Step 2 Attaching Plug-In Serial Interface Module to Wall Receptacle:

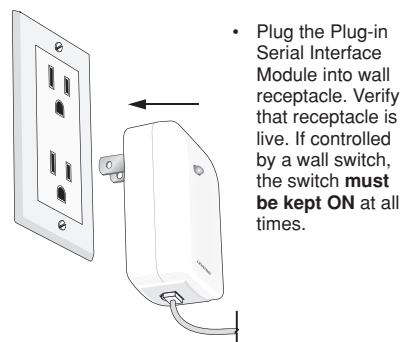

Step 3 Including Plug-In Serial Interface Module into Z-Wave™ Network:

NOTES:

- If using a non-Leviton Programmer/Remote, refer to the Programmer/Remote instruction sheet.
 - Plug-In Serial Interface Modules included into a Z-Wave™ network must be updated after you have included all other devices.
- A) If using a Leviton Z-Wave™ Programmer/Remote, Cat. No. RZCPG, press the Menu button and scroll down to System Setup. Press the center button to select System Setup Menu. Press the center button to select Network. Press the center button to <Include Node>.
 - B) If using RZCPG Programmer/Remote, you will be prompted to prepare device for inclusion. To do this you must put the Plug-In Serial Interface Module into programming mode.
 - C) To access Program mode, press and hold programming button until the LED turns Amber. You are now in Programming mode.
NOTE: If the LED on the Plug-In Serial Interface Module turns solid Red while including, there has been a communication error.
 - D) While standing close to the Plug-In Serial Interface Module (approximately 2-5 ft.), press the center button on the Programmer/Remote to <Include> device in the network. **NOTE:** Only one device may be included at any time.

Step 3 cont'd

- E) The Primary Programmer/Remote will assign a Home ID, Node ID, and Name for this device.
NOTE: This information will be stored in the Programmer/Remote to be used for future reference.
NOTE: You may name or edit the node of this device at this time.
- F) **The Plug-In Serial Interface Module is now installed in the network.**
- G) After all devices are included into the network, the Plug-In Serial Interface Module must be updated to allow proper network function. To update Plug-In Serial Interface Module proceed as follows:
 - If using a non-Leviton Programmer/Remote, refer to the Programmer/Remote instruction sheet for updating Plug-In Serial Interface Module.
 - If using Leviton Z-Wave™ Programmer/Remote, Cat. No. RZCPG, press the Menu button and scroll down to System Setup. Press the center button to select System Setup Menu. Press the center button to select Network. Press the center button to select Update "ctrl". When prompted, press button on the Plug-In Serial Interface Module.
 - Wait until the RZCPG Programmer/Remote confirms completion. Update is done.

NOTE: If the Plug-In Serial Interface Module has been successfully Included in the network and the user tries to Include it again without first excluding it from the network, the controller will retain the first node ID it had received and ignore the second.

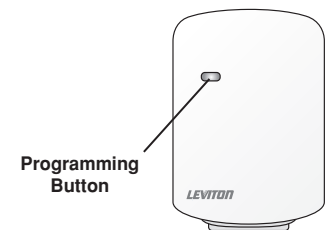
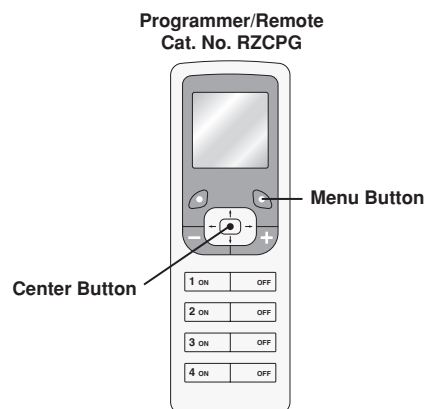

Step 3 cont'd Including Plug-In Serial Interface Module into Z-Wave™ Network:

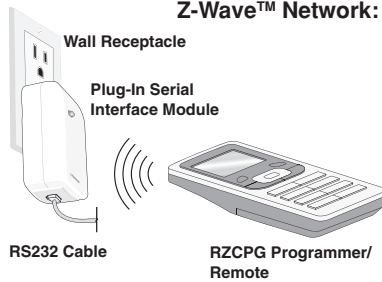

NOTE: Programmer/Remote must be in close proximity to Plug-In Serial Interface Module when including into network

Step 4 Excluding Plug-In Serial Interface Module from Network:

NOTE: It is very important to accurately Exclude devices from the network when moving or removing a device from a Z-Wave™ network. This ensures that all information has been removed from your Primary Programmer/Remote's information table and is not counted on to be a part of the mesh network.

- If using a Leviton Z-Wave™ Programmer/Remote, Cat. No. RZCPG, press the Menu button and scroll down to System Setup. Press the center button to select System Setup Menu. Press the center button to select Network. Scroll down to <Exclude Node> and press the center button.
- If using RZCPG Programmer/Remote you will be prompted to prepare device for exclusion. To do this, you must put the Plug-In Serial Interface Module into programming mode.
- To access Program mode, press and hold programming button until the LED turns Amber. You are now in Programming mode.
NOTE: If the LED on the Plug-In Serial Interface Module turns solid Red while excluding, there has been a communication error.
- While standing close to the Plug-In Serial Interface Module (approximately 2-5 ft.), press the center button to <Exclude> device from the network.

Step 4 cont'd

Factory Default:

If your module is not responding, or you are unable to control it after you have tried to Include/Exclude it multiple times, it may be necessary to reset the module to its original factory settings. To accomplish this, proceed as follows:

- Unplug the module and wait 5 seconds. Plug the module back in and within 20 seconds press and hold the programming button until the LED flashes Amber and turns solid Red. The module is now reset. Once the module is reset, it will be necessary to Re-Include it to a network before it can be used.

CAUTION: SETTING A DEVICE TO A FACTORY DEFAULT DOES NOT EXCLUDE THAT DEVICE FROM A NETWORK. THE EXCLUSION PROCEDURE MUST STILL BE FOLLOWED TO REMOVE THE DEVICE FROM THE PRIMARY REMOTE'S INFORMATION TABLE. FAILURE TO DO SO MAY RESULT IN SYSTEM THAT IS SLOW TO RESPOND, OR MAY FAIL TO RESPOND TO SOME DEVICES.

OPERATION

NOTE: For complete details on operating the Primary Programmer/Remote, refer to the instruction guide for that particular device.

The RZCØP is intended for use by developers who want to develop products that can transmit signals to and receive signals from ViziaRF™ products on a Z-Wave™ network. A relatively high level of programming knowledge is required to develop products that use these interfaces. The interface uses a simple ACSII protocol to communicate to the controlling equipment. If you are an end user who has purchased this product to work with another product that was designed for this purpose, please refer to that product's owner's manual for operating instructions.

If you are a developer who has purchased this interface to develop a ViziaRF™ compatible product, you will need the RZCØP Tech Note, which contains the information needed to allow proper interface communication. Please visit our website listed below to download the RZCØP Tech note.

www.ViziaRF.com

COMMUNICATION SETTINGS

NOTE: The following general information applies to the RS232 Interface.

To configure your device to communicate with the interface, use the following data conventions:

9600 BAUD
8 DATA
1 STOP
NO PARITY

If you wish to send these commands from a PC, run the Microsoft Windows® Hyper Terminal program or an equivalent program. Then select Local Echo, Line Feed and Carriage Return inbound and outbound. This allows you to see the characters that you are typing as well as keep the responses from overwriting typed characters.

TROUBLESHOOTING

- Plug-In Serial Interface Module is functioning improperly**
 - Confirm that the device is being supplied from a 120V, 60Hz AC source ONLY.
 - Confirm that the unit is programmed properly. Repeat "INSTALLING YOUR INTERFACE MODULE" section to verify that it has been included into the Z-Wave™ network.
- Programmer/Remote does not operate lights**
 - Check association.
 - Ensure that Plug-In Serial Interface Module was properly updated.

For additional information, contact Leviton's Techline at 1-800-824-3005 or visit Leviton's website at www.ViziaRF.com

U.S. & Foreign Patents Pending
Copyright© 2006 Leviton Manufacturing Co., Inc.
All Rights Including Trade Dress Rights Reserved

FCC COMPLIANCE STATEMENT

This equipment has been tested and found to comply with the limits for a Class B Digital Device, pursuant to Part 15 of the FCC Rules. These limits are designed to provide reasonable protection against harmful interference in a residential installation. This equipment generates, uses, and can radiate radio frequency energy and, if not installed and used in accordance with the instructions, may cause harmful interference to radio communications. However, there is no guarantee that interference will not occur in a particular installation. If this equipment does cause harmful interference to radio or television reception, which can be determined by turning the equipment OFF and ON, the user is encouraged to try to correct the interference by one or more of the following measures:

- Reorient or relocate the receiving Antenna.
- Increase the separation between the equipment and the receiver.
- Connect the equipment into an outlet on a circuit different from that to which the receiver is connected.
- Consult the dealer or an experienced radio/ tv technician for help.

DI-000-RZCØP-00A-X3

LIMITED 5 YEAR WARRANTY AND EXCLUSIONS

Leviton warrants to the original consumer purchaser and not for the benefit of anyone else that this product at the time of its sale by Leviton is free of defects in materials and workmanship under normal and proper use for five years from the purchase date. Leviton's only obligation is to correct such defects by repair or replacement, at its option, if within such five year period the product is returned prepaid, with proof of purchase date, and a description of the problem to Leviton Manufacturing Co., Inc., Att: Quality Assurance Department, 59-25 Little Neck Parkway, Little Neck, New York 11362-2591. This warranty excludes and there is disclaimed liability for labor for removal of this product or reinstallation. This warranty is void if this product is installed improperly or in an improper environment, overloaded, misused, opened, abused, or altered in any manner, or is not used under normal operating conditions or not in accordance with any labels or instructions. There are no other or implied warranties of any kind, including merchantability and fitness for a particular purpose, but if any implied warranty is required by the applicable jurisdiction, the duration of any such implied warranty, including merchantability and fitness for a particular purpose, is limited to five years. Leviton is not liable for incidental, indirect, special, or consequential damages, including without limitation, damage to, or loss of use of, any equipment, lost sales or profits or delay or failure to perform this warranty obligation. The remedies provided herein are the exclusive remedies under this warranty, whether based on contract, tort or otherwise.

LEVITON INSTRUCTION SHEET/MANUAL SPECIFICATIONS

- Artwork No/Rev Level: DI-000-RZC0P-00A-X3
- Color(s): Black over _____
 1. _____ 2. _____
 3. _____ 4. _____
- Font Families: Helvetica
- Material
 Type: 40 Lb. offset
- Coating: _____
- Paper size:
 Overall size: 9.75" X 8.5"
 Final fold size: 2.44" X 4.25"

DOCUMENTATION

- ECO No.: N/A
- Artist: H2D Date: 1/08/07

The information in this document is the exclusive PROPRIETARY property of LEVITON MANUFACTURING COMPANY, INC. It is disclosed with the understanding that acceptance or review by the recipient constitutes an undertaking by the recipient. (1) to hold this information in strict confidence, and (2) not to disclose, duplicate, copy, modify, or use the information for any purpose other than that for which disclosed.

Copyright © 1997 Leviton Mfg. Co. Inc.
 Unpublished, All Rights Reserved

FOLD SCHEME

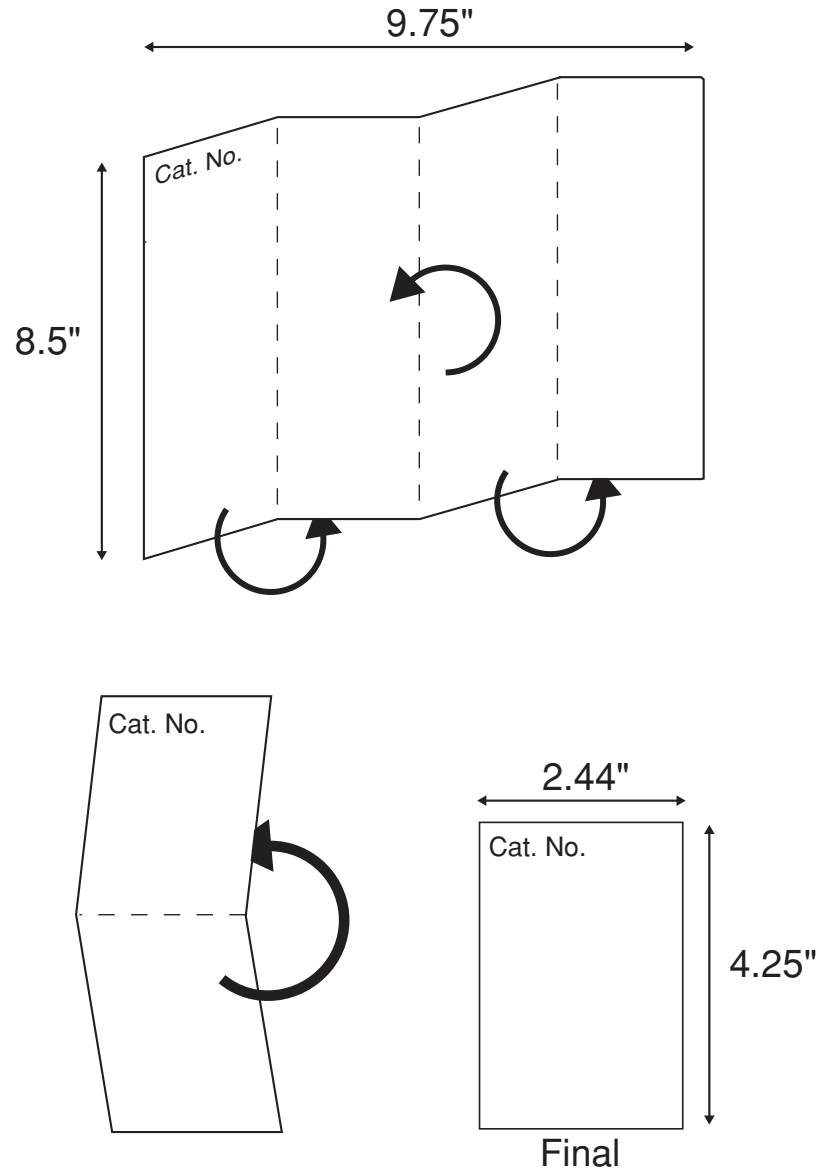

— — — Fold Line