



C734 and C736 Series

User's Guide

www.lexmark.com

Machine types/model numbers:

5026: 210, 230, 280, 410, 430, 480

4976: n01, n02, n03, gn1, gn2, dn1, dn2, dn3, gd1, gd2, dw1, dw2, gw1, gw2

4977: n01, n02, n03, gn1, gn2, dn1, dn2, dn3, gd1, gd2

Contents

Safety information.....	9
Learning about the printer.....	11
Finding information about the printer.....	11
Selecting a location for the printer.....	12
Printer configurations.....	13
Using the security lock feature.....	15
Understanding the printer control panel.....	15
Additional printer setup.....	17
Installing internal options.....	17
Available internal options.....	17
Accessing the system board to install internal options.....	18
Installing a memory card.....	19
Installing a flash memory or firmware card.....	21
Installing an Internal Solutions Port.....	23
Installing a printer hard disk.....	29
Reattaching the system board cover.....	32
Attaching cables.....	33
Installing optional trays.....	35
Verifying printer setup.....	37
Printing a menu settings page.....	37
Printing a network setup page.....	37
Setting up the printer software.....	37
Installing printer software.....	37
Updating available options in the printer driver.....	38
Setting up wireless printing.....	39
Information you will need to set up the printer on a wireless network.....	39
Installing the printer on a wireless network (Windows).....	40
Installing the printer on a wireless network (Macintosh).....	41
Installing the printer on a wired network.....	44
Changing port settings after installing a new network Internal Solutions Port.....	46
Setting up serial printing.....	48
Minimizing your printer's environmental impact.....	50
Saving paper and toner.....	50
Using recycled paper.....	50
Conserving supplies.....	50

- Saving energy.....51
 - Using Eco-Mode 51
 - Reducing printer noise 52
 - Adjusting Power Saver..... 52
 - Adjusting the brightness of the display 53
- Recycling.....54
 - Recycling Lexmark products..... 54
 - Recycling Lexmark packaging..... 54
 - Returning Lexmark cartridges for reuse or recycling..... 54

Loading paper and specialty media.....55

- Setting the paper size and type.....55
- Loading the paper tray.....55
- Loading the multipurpose tray.....58
- Linking and unlinking trays.....61
 - Linking trays..... 61
 - Unlinking trays..... 61

Paper and specialty media guide.....63

- Paper guidelines.....63
 - Paper characteristics..... 63
 - Unacceptable paper 64
 - Selecting paper..... 64
 - Selecting preprinted forms and letterhead..... 64
 - Using recycled paper and other office papers 65
- Storing paper.....65
- Supported paper sizes, types, and weights.....66
 - Supported paper sizes 66
 - Supported paper types and weights 67

Printing.....69

- Printing a document.....69
 - Printing a document..... 69
- Printing specialty documents.....69
 - Printing on letterhead 69
 - Tips on using transparencies 70
 - Tips on using envelopes..... 71
 - Tips on using labels..... 71
 - Tips on using card stock..... 72
- Printing confidential and other held jobs.....72
 - Holding jobs in the printer 72
 - Printing confidential and other held jobs..... 73

Printing from a flash drive.....	75
Printing photos from a PictBridge-enabled digital camera.....	76
Printing information pages.....	76
Printing a font sample list.....	76
Printing a directory list.....	77
Printing the print quality test pages.....	77
Canceling a print job.....	77
Canceling a print job from the printer control panel.....	77
Canceling a print job from the computer.....	77
Printing in black and white.....	78
Using Max Speed and Max Yield.....	79

Clearing jams.....80

Avoiding jams.....	80
Understanding jam messages.....	80
200 paper jams.....	81
200 or 201 paper jam.....	82
201 paper jam.....	83
202 paper jam.....	84
203 paper jam.....	86
230 paper jam.....	87
240 paper jam.....	88
250 paper jam.....	90

Understanding printer menus.....91

Menus list.....	91
Supplies menu.....	92
Paper menu.....	93
Default Source menu.....	93
Paper Size/Type menu.....	93
Configure MP menu.....	96
Substitute Size menu.....	96
Paper Texture menu.....	97
Paper Weight menu.....	98
Paper Loading menu.....	100
Custom Types menu.....	101
Universal Setup menu.....	101
Reports menu.....	102
Reports menu.....	102
Network/Ports menu.....	103

Active NIC menu.....	103
Standard Network or Network <x> menus	103
Network Reports menu	105
Network Card menu.....	106
TCP/IP menu	106
IPv6 menu.....	107
Wireless menu.....	108
AppleTalk menu	108
NetWare menu.....	109
LexLink menu	110
Standard USB and USB <x> menus.....	110
Parallel <x> menu.....	112
Serial <x> menu	114
SMTP Setup menu	116
Security menu.....	117
Miscellaneous menu	117
Confidential Print menu	118
Disk Wiping menu	119
Security Audit Log menu	120
Set Date/Time menu.....	121
Settings menu.....	121
General Settings menu	121
Setup menu	125
Finishing menu.....	127
Quality menu.....	128
Utilities menu	132
XPS menu.....	133
PDF menu	133
PostScript menu.....	133
PCL Emul menu	134
HTML menu.....	137
Image menu.....	138
PictBridge menu.....	139
Flash Drive menu	139
Help menu.....	141

Understanding printer messages.....143

List of status and error messages.....	143
----------------------------------------	-----

Maintaining the printer.....157

Cleaning the exterior of the printer.....	157
Cleaning the printhead lenses.....	157
Storing supplies.....	159

Checking the status of supplies.....	159
Checking the status of supplies from the printer control panel.....	159
Checking the status of supplies from a network computer	160
Ordering supplies.....	160
Ordering toner cartridges.....	160
Ordering photoconductors.....	160
Ordering a fuser or a transfer module.....	160
Ordering a waste toner box	161
Replacing Supplies.....	162
Replacing a photoconductor	162
Replacing a toner cartridge.....	165
Replacing the waste toner box.....	169
Moving the printer.....	170
Before moving the printer	170
Moving the printer to another location.....	171
Setting the printer up in a new location	171
Shipping the printer	172

Administrative support.....173

Finding advanced networking and administrator information.....	173
Using the Embedded Web Server.....	173
Checking the virtual display.....	173
Checking the device status.....	174
Setting up e-mail alerts.....	174
Viewing reports.....	174
Restoring the factory default settings.....	175

Troubleshooting.....176

Checking an unresponsive printer.....	176
Solving printing problems.....	176
Multiple-language PDFs do not print.....	176
Printer control panel display is blank or displays only diamonds.....	176
Error message about reading USB drive appears.....	176
Jobs do not print.....	176
Confidential and other held jobs do not print	177
Job takes longer than expected to print	178
Job prints from the wrong tray or on the wrong paper	178
Incorrect characters print.....	178
Tray linking does not work.....	178
Large jobs do not collate	179
Unexpected page breaks occur.....	179

Solving option problems.....	179
Option does not operate correctly or quits after it is installed	179
Trays / Drawers	180
Flash memory card.....	180
Hard disk with adapter.....	180
Internal Solutions Port	181
Internal print server	181
Memory card	181
USB/parallel interface card	181
Solving paper feed problems.....	182
Paper frequently jams	182
Paper jam message remains after jam is cleared	182
Page that jammed does not reprint after you clear the jam.....	182
Solving print quality problems.....	183
Isolating print quality problems.....	183
Blank pages.....	183
Characters have jagged or uneven edges	183
Color misregistration.....	184
Clipped images.....	184
Fine horizontal lines appear on color pages.....	185
Ghost images.....	185
Gray background	185
Incorrect margins.....	185
Light colored line, white line, or incorrectly colored line.....	185
Paper curls badly.....	186
Print irregularities	186
Print is too dark.....	186
Print is too light	187
Repeating defects.....	187
Skewed print.....	188
Solid color pages.....	188
Streaked horizontal lines.....	188
Streaked vertical lines	188
Toner fog or background shading appears on the page	189
Toner rubs off.....	189
Toner specks.....	189
Transparency print quality is poor.....	189
Uneven print density	190
Solving color quality problems.....	190
FAQ about color printing	190
Embedded Web Server does not open.....	193
Check the network connections	193
Check the network settings	193

Contacting Customer Support.....	193
Notices.....	194
Product information.....	194
Edition notice.....	194
Power consumption.....	198
Index.....	211

Safety information

Connect the power supply cord to a properly grounded electrical outlet that is near the product and easily accessible.

 **CAUTION—POTENTIAL INJURY:** Do not twist, bind, crush, or place heavy objects on the power cord. Do not subject the power cord to abrasion or stress. Do not pinch the power cord between objects such as furniture and walls. If the power cord is misused, a risk of fire or electrical shock results. Inspect the power cord regularly for signs of misuse. Remove the power cord from the electrical outlet before inspecting it.

Do not place or use this product near water or wet locations.

Use only the power cord provided with this product or the manufacturer's authorized replacement.

Refer service or repairs, other than those described in the user documentation, to a professional service person.

 **CAUTION—SHOCK HAZARD:** Do not use the fax feature during a lightning storm. Do not set up this product or make any electrical or cabling connections, such as the power supply cord or telephone, during a lightning storm.

This product is designed, tested, and approved to meet strict global safety standards with the use of specific manufacturer's components. The safety features of some parts may not always be obvious. The manufacturer is not responsible for the use of other replacement parts.

 **CAUTION—SHOCK HAZARD:** Make sure that all external connections (such as Ethernet and telephone system connections) are properly installed in their marked plug-in ports.

 **CAUTION—POTENTIAL INJURY:** This product uses a laser. Use of controls or adjustments or performance of procedures other than those specified herein may result in hazardous radiation exposure.

This product uses a printing process that heats the print media, and the heat may cause the media to release emissions. You must understand the section in your operating instructions that discusses the guidelines for selecting print media to avoid the possibility of harmful emissions.

 **CAUTION—HOT SURFACE:** The fuser and the inside of the printer near the fuser may be hot. Wait for the fuser to cool before clearing jams from this area.

This product contains a lithium battery.



CAUTION—POTENTIAL INJURY: There is a risk of explosion if the battery is replaced with an incorrect type. Discard used batteries according to the battery manufacturer's instructions and local regulations.



CAUTION—SHOCK HAZARD: If you are installing memory or option cards sometime after setting up the printer, turn the printer off and unplug the power cord from the wall outlet before continuing. If you have any other devices attached to the printer, turn them off as well and unplug any cables going to the printer.



CAUTION—SHOCK HAZARD: If you are installing an optional tray after setting up the printer, then turn the printer off and unplug the power cord, the USB cable, and the Ethernet cable before continuing.



CAUTION—SHOCK HAZARD: If you are installing an Internal Solutions Port (ISP) after setting up the printer, then turn the printer off and unplug the power cord from the wall outlet before continuing.



CAUTION—SHOCK HAZARD: To avoid the risk of electric shock when cleaning the exterior of the printer, unplug the power cord from the wall outlet and disconnect all cables from the printer before proceeding.



CAUTION—TIPPING HAZARD: Floor-mounted configurations require additional furniture for stability. You must use either a printer stand or printer base if you are using a high-capacity input tray, a duplex unit and an input option, or more than one input option. If you purchased a multifunction printer (MFP) that scans, copies, and faxes, you may need additional furniture. For more information, see www.lexmark.com/multifunctionprinters.



CAUTION—POTENTIAL INJURY: The printer weight is greater than 18 kg (40 lb) and requires two or more trained personnel to lift it safely.

Learning about the printer

Finding information about the printer

Setup information

Description	Where to find
The <i>Setup</i> information gives you instructions for setting up the printer. Follow the set of instructions for local, network, or wireless, depending on what you need.	You can find the <i>Setup</i> information in the printer box or on the Lexmark Web site at www.lexmark.com .

Wireless Setup Guide

Description	Where to find
If your printer has built-in wireless functionality, a <i>Wireless Setup Guide</i> gives you instructions for connecting the printer wirelessly.	You can find the <i>Wireless Setup Guide</i> in the printer box or on the Lexmark Web site at www.lexmark.com .

Help

Description	Where to find
The Help gives you instructions for using the software.	While in any Lexmark software program, click Help, Tips → Help , or Help → Help Topics .

Customer support

Description	Where to find (North America)	Where to find (rest of world)
Telephone support	<p>Call us at</p> <ul style="list-style-type: none">• US: 1-800-332-4120 Monday–Friday (8:00 AM–11:00 PM ET) Saturday (Noon–6:00 PM ET)• Canada: 1-800-539-6275 Monday–Friday (8:00 AM–11:00 PM ET) Saturday (Noon–6:00 PM ET)• Mexico: 001-888-377-0063 Monday–Friday (8:00 AM–8:00 PM ET) <p>Note: Telephone numbers and support times may change without notice. For the most recent telephone numbers available, see the printed warranty statement that came with your printer.</p>	<p>Telephone numbers and support hours vary by country or region.</p> <p>Visit our Web site at www.lexmark.com. Select a country or region, and then select the Customer Support link.</p> <p>Note: For additional information about contacting Lexmark, see the printed warranty that came with your printer.</p>

Description	Where to find (North America)	Where to find (rest of world)
E-mail support	<p>For e-mail support, visit our Web site: www.lexmark.com.</p> <ol style="list-style-type: none"> 1 Click SUPPORT. 2 Click Technical Support. 3 Select your printer type. 4 Select your printer model. 5 From the Support Tools section, click e-Mail Support. 6 Complete the form, and then click Submit Request. 	<p>E-mail support varies by country or region, and may not be available in some instances.</p> <p>Visit our Web site at www.lexmark.com. Select a country or region, and then select the Customer Support link.</p> <p>Note: For additional information about contacting Lexmark, see the printed warranty that came with your printer.</p>

Selecting a location for the printer

When selecting a location for the printer, leave enough room to open trays, covers, and doors. If you plan to install any options, leave enough room for them also. It is important to:

- Make sure airflow in the room meets the latest revision of the ASHRAE 62 standard.
- Provide a flat, sturdy, and stable surface.
- Keep the printer:
 - Away from the direct airflow of air conditioners, heaters, or ventilators
 - Free from direct sunlight, humidity extremes, or temperature fluctuations
 - Clean, dry, and free of dust
- Allow the following recommended amount of space around the printer for proper ventilation:

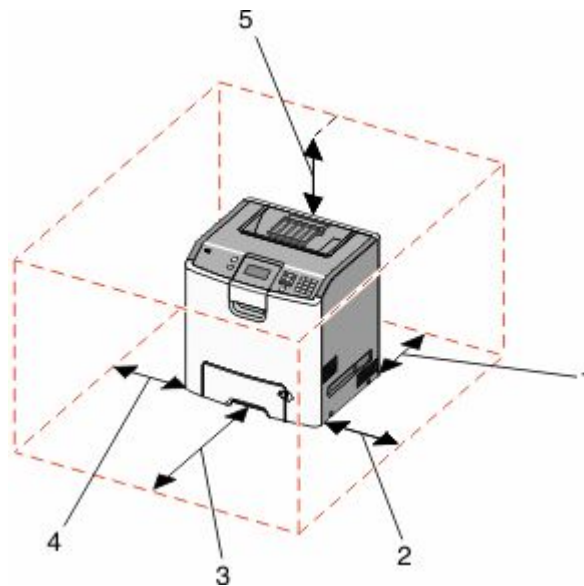

1	152.4 mm (6.0 in.)
2	101.6 mm (4.0 in.)
3	609.6 mm (24.0 in.)

4	101.6 mm (4.0 in.)
5	304.8 mm (12.0 in.)

When the printer is set up, allow clearance around it as shown.

Printer configurations

Basic model

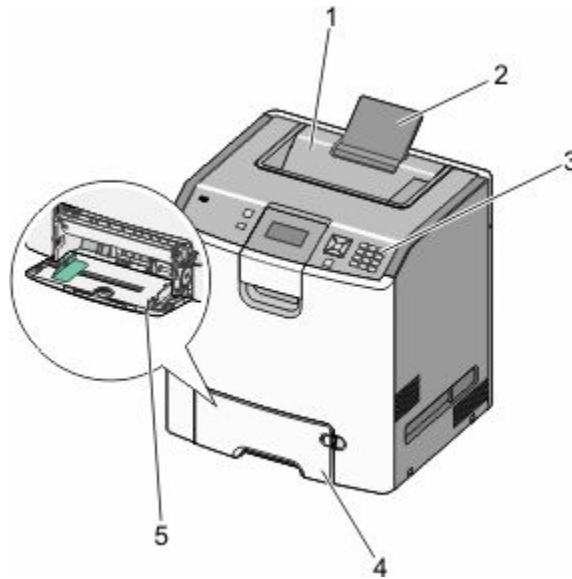

1	Standard exit bin
2	Paper support
3	Printer control panel
4	Standard 550-sheet tray (Tray 1)
5	Multipurpose tray

Configured models

CAUTION—TIPPING HAZARD: Floor-mounted configurations require additional furniture for stability. You must use either a printer stand or printer base if you are using a high-capacity input tray, a duplex unit and an input option, or more than one input option. If you purchased a multifunction printer (MFP) that scans, copies, and faxes, you may need additional furniture. For more information, see www.lexmark.com/multifunctionprinters.

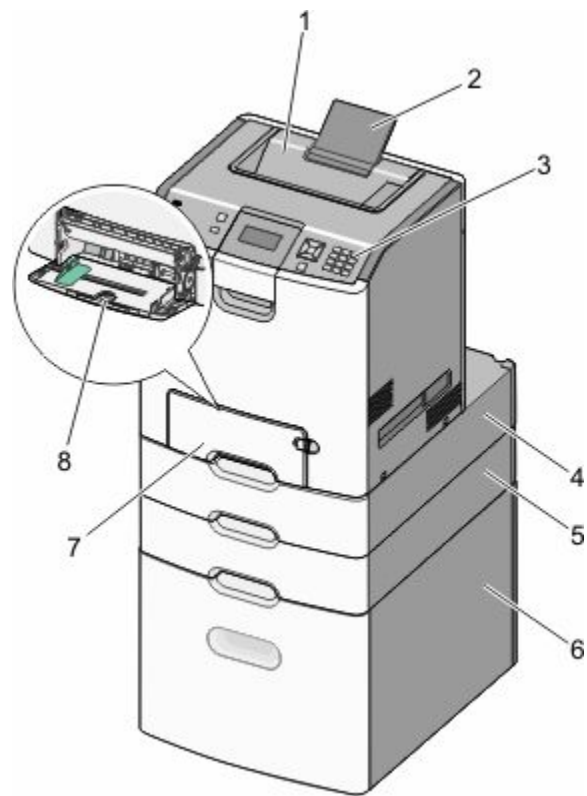

1	Standard exit bin
2	Paper support
3	Printer control panel
4	Optional 550-sheet specialty media drawer
5	Optional 550-sheet tray
6	Optional 2,000-sheet tray
7	Standard 550-sheet tray (Tray 1)
8	Multipurpose tray

Using the security lock feature



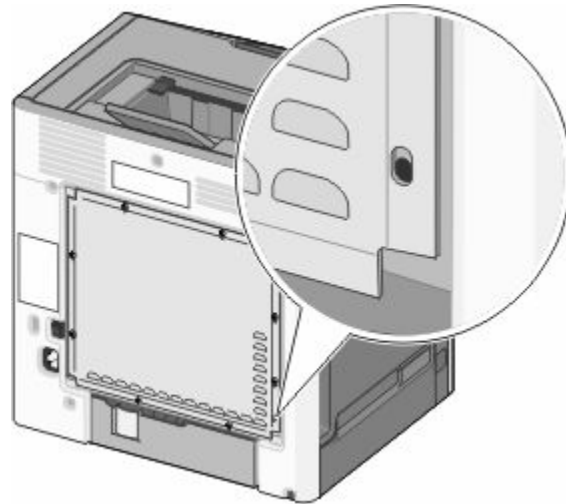

The printer is equipped with a security lock feature. When a lock compatible with most laptop computers is attached, the printer is locked. Once locked, the metal plate and the system board cannot be removed. Attach a security lock to the printer in the location shown.

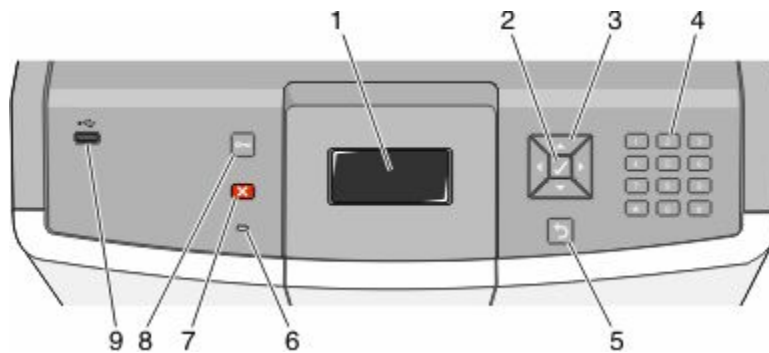

Understanding the printer control panel

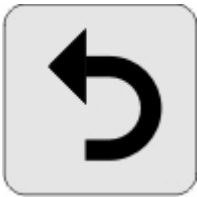

Control panel item		Description
1	Display	The display shows messages and pictures that communicate the status of the printer.
2	Select	Pressing  initiates action on a menu item.

Control panel item		Description
3	Navigation buttons	 <p>Press the up or down arrow button to scroll through menu lists. Press the left or right arrow button to scroll through values or text that rolls to another screen.</p>
4	Numeric keypad	 <p>Consists of the numbers 0–9, characters A through Z, an ↑A, and a backspace button. Note: The ↑A button functions as Caps Lock, and includes the # character.</p>
5	Back	 <p>Returns the display to the previous screen</p>
6	Indicator light	<p>Indicates the printer status:</p> <ul style="list-style-type: none"> • Off—The power is off, or the printer is in Eco Mode. • Blinking green—The printer is warming up, processing data, or printing. • Solid green—The printer is on, but idle. • Solid red—Operator intervention is needed.
7	Stop	 <p>Stops all printer activity A list of options is offered once Stopped appears on the display.</p>
8	Menus	 <p>Opens the menus index Note: These menus are available only when the printer is in the Ready state.</p>
9	USB Direct port	<p>Insert a USB flash drive to send data to the printer. Insert a USB cable from a digital camera to print photos with a PictBridge-enabled digital camera.</p>

Additional printer setup

Installing internal options

 **CAUTION—SHOCK HAZARD:** If you are installing memory or option cards sometime after setting up the printer, then turn the printer off and unplug the power cord from the wall outlet before continuing. If you have any other devices attached to the printer, then turn them off as well, and unplug any cables going to the printer.

You can customize your printer connectivity and memory capacity by adding optional cards. The instructions in this section explain how to install the available cards; you can also use them to locate a card for removal.

Available internal options

- Memory cards
 - Printer memory
 - Flash memory
 - Fonts
- Firmware cards
 - Bar Code
 - PrintCrypton™
- Printer hard disk
- Lexmark™ Internal Solutions Ports (ISP)
 - RS-232-C Serial ISP
 - Parallel 1284-B ISP
 - MarkNet™ N8150 802.11 b/g/n Wireless ISP
 - MarkNet N8130 10/100 Fiber ISP
 - MarkNet N8120 10/100/1000 Ethernet ISP

Accessing the system board to install internal options

CAUTION—SHOCK HAZARD: If you are installing memory or option cards sometime after setting up the printer, then turn the printer off and unplug the power cord from the wall outlet before continuing. If you have any other devices attached to the printer, then turn them off as well, and unplug any cables going to the printer.

Note: This operation requires a flathead screwdriver.

- 1** Remove the cover.
 - a** Turn the screws on the cover counterclockwise to loosen them, but do not remove them.

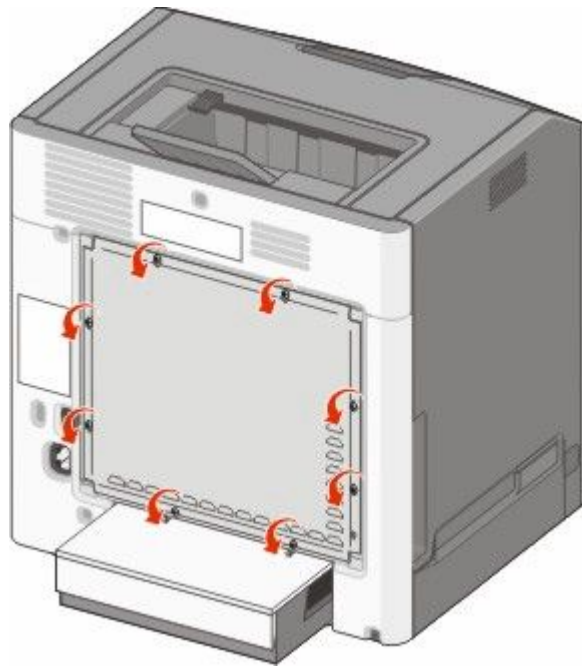

- b** Slide the cover up until each screw is in the keyhole.

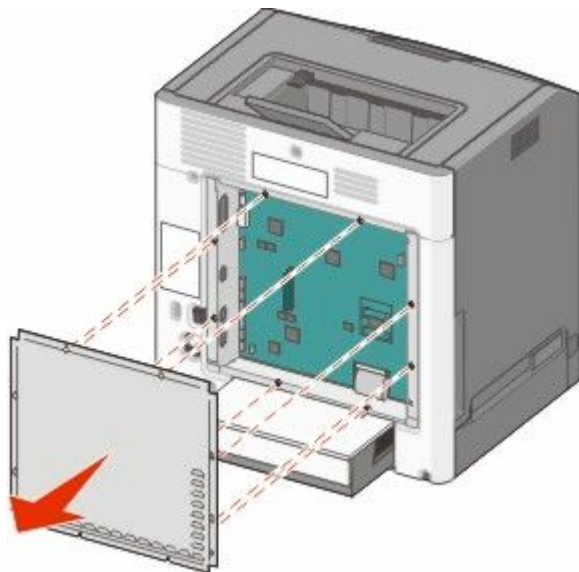

- c** Pull the cover forward to remove it.

2 Use the following illustration to locate the appropriate connector.

Warning—Potential Damage: System board electrical components are easily damaged by static electricity. Touch something metal on the printer before touching any system board electronic components or connectors.

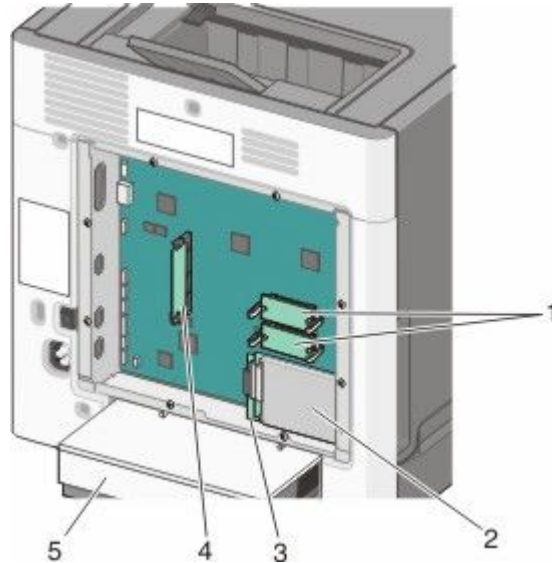

1	Firmware and flash memory card connectors
2	Hard disk connector
3	Internal print server connector
4	Memory card connector
5	Dust cover

Installing a memory card

CAUTION—SHOCK HAZARD: If you are installing memory or option cards sometime after setting up the printer, then turn the printer off and unplug the power cord from the wall outlet before continuing. If you have any other devices attached to the printer, then turn them off as well and unplug any cables going to the printer.

Warning—Potential Damage: System board electrical components are easily damaged by static electricity. Touch something metal on the printer before touching any system board electronic components or connectors.

An optional memory card can be purchased separately and attached to the system board. To install the memory card:

- 1 Access the system board.
- 2 Unpack the memory card.

Note: Avoid touching the connection point along the edge of the card.

3 Open the memory card connector latches.



4 Align the notch on the memory card with the ridge on the connector.

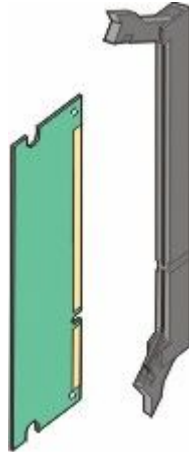

1	Notch
2	Ridge

5 Push the memory card straight into the connector until it *snaps* into place.

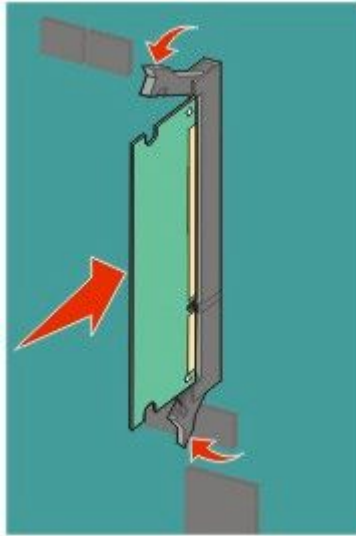

6 Reattach the system board cover.

Installing a flash memory or firmware card

The system board has two connections for an optional flash memory or firmware card. Only one of each may be installed, but the connectors are interchangeable.

CAUTION—SHOCK HAZARD: If you are installing memory or option cards sometime after setting up the printer, then turn the printer off and unplug the power cord from the wall outlet before continuing. If you have any other devices attached to the printer, then turn them off as well, and unplug any cables going to the printer.

Warning—Potential Damage: System board electronic components are easily damaged by static electricity. Touch something metal on the printer before touching any system board electronic components or connectors.

1 Access the system board.

2 Unpack the card.

Note: Avoid touching the connection points along the edge of the card.

3 Holding the card by its sides, align the plastic pins on the card with the holes on the system board.

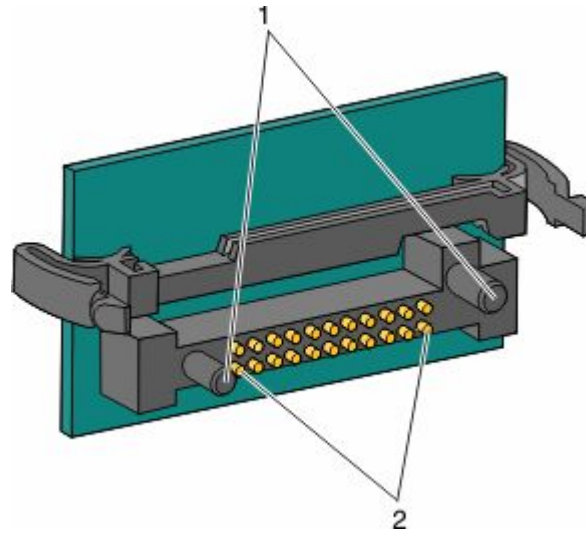

1	Plastic pins
2	Metal pins

4 Push the card firmly into place.

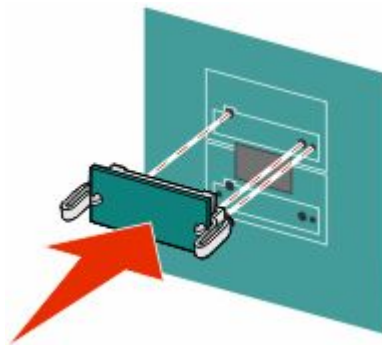

Notes:

- The entire length of the connector on the card must touch and be flush against the system board.
- Be careful not to damage the connectors.

5 Reattach the system board cover.

Installing an Internal Solutions Port

The system board supports one optional Lexmark Internal Solutions Port (ISP).

Note: This task requires a flathead screwdriver.

CAUTION—SHOCK HAZARD: If you are installing an Internal Solutions Port (ISP) after setting up the printer, then turn the printer off and unplug the power cord from the wall outlet before continuing.

Warning—Potential Damage: System board electronic components are easily damaged by static electricity. Touch something metal on the printer before touching any system board electronic components or connectors.

- 1 Access the system board.
- 2 Unpack the ISP and plastic tee.
Note: Avoid touching the components on the card.
- 3 Locate the appropriate connector on the system board.

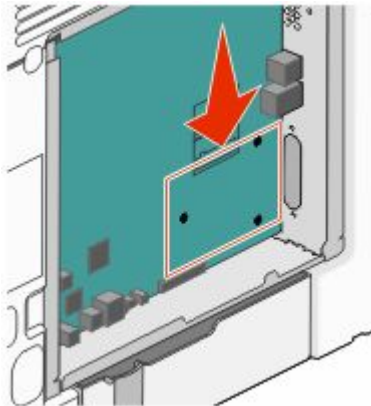

Note: If an optional printer hard disk is currently installed, then it must first be removed. To remove the printer hard disk:

- a** Unplug the printer hard disk interface cable from the system board, leaving the cable attached to the printer hard disk. To unplug the cable, squeeze the paddle at the plug of the interface cable to disengage the latch before pulling the cable out.

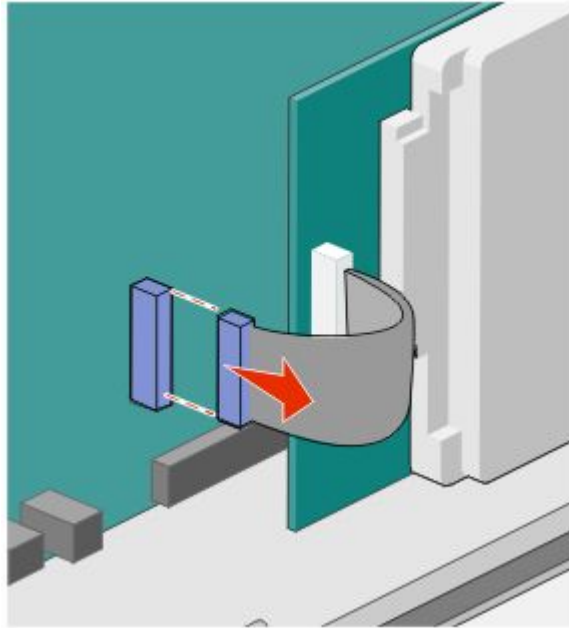

- b** Remove the screws holding the printer hard disk in place.

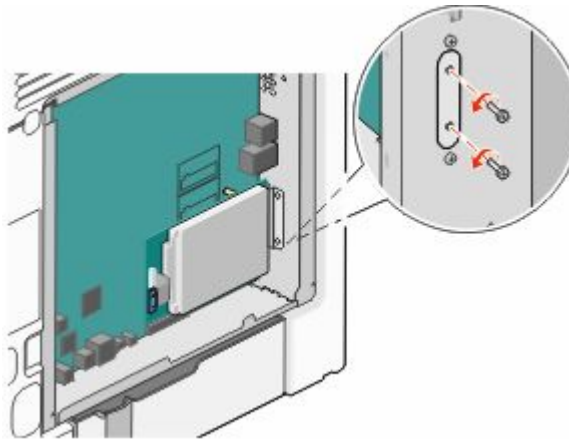

- c Remove the printer hard disk by pulling it upward to unseat the standoffs.

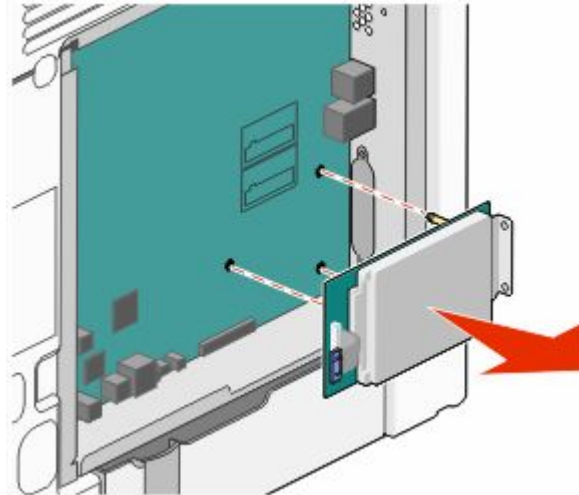

- d Remove the thumbscrews that attach the printer hard disk mounting bracket to the printer hard disk, and then remove the bracket. Set the printer hard disk aside.

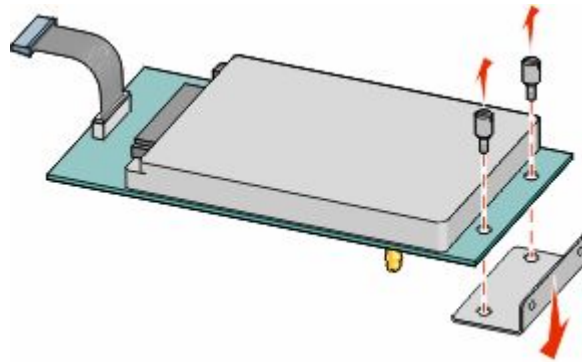

- 4 Remove the metal cover from the ISP opening.

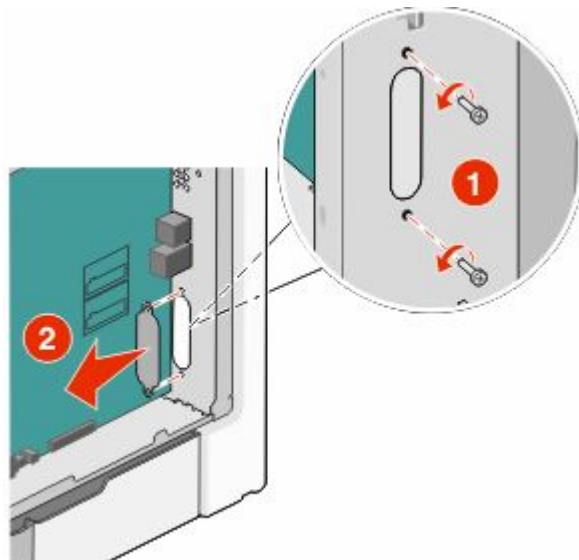

- 5** Align the posts of the plastic tee to the holes in the system board, and press downward until the tee *snaps* into place. Be sure each post of the tee has latched completely, and the tee is seated firmly on the system board.

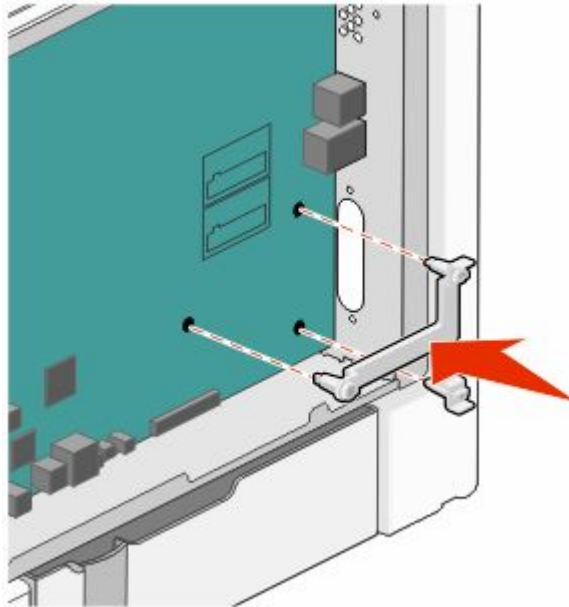

- 6** Install the ISP on the plastic tee. Angle the ISP over the plastic tee, and approach the plastic tee so that any overhanging connectors will pass through the ISP opening in the system board cage.

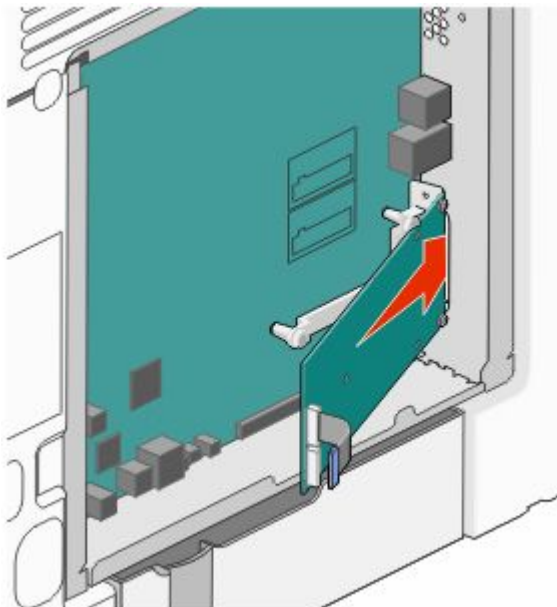

7 Lower the ISP toward the plastic tee until the ISP is seated between the guides of the plastic tee.

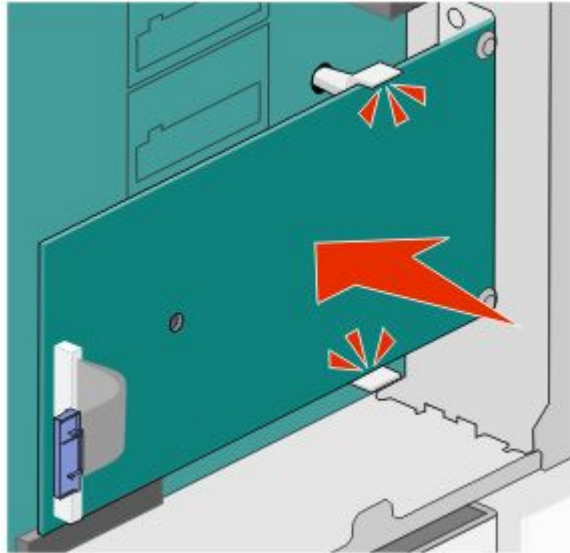

8 Insert the long thumbscrew and turn it clockwise enough to hold the ISP in place, but do not tighten the thumbscrew at this time.

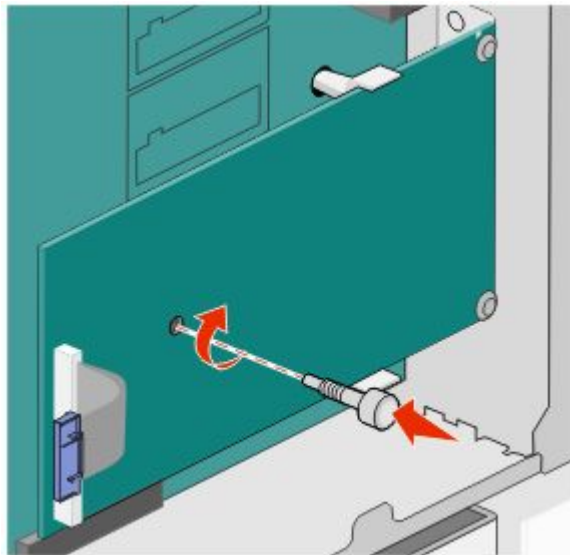

9 Attach the two provided screws to secure the ISP mounting bracket to the system board cage.

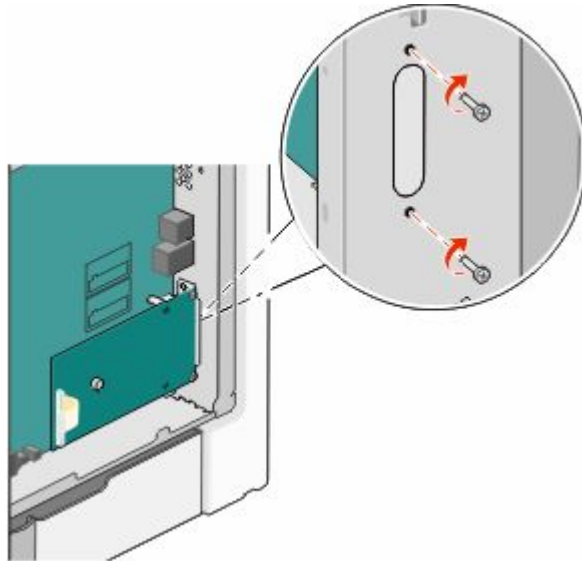

10 Tighten the long thumbscrew.

Warning—Potential Damage: Do not overtighten the thumbscrew.

11 Insert the plug of the ISP interface cable into the receptacle of the system board.

Note: The plugs and receptacles are color-coded.

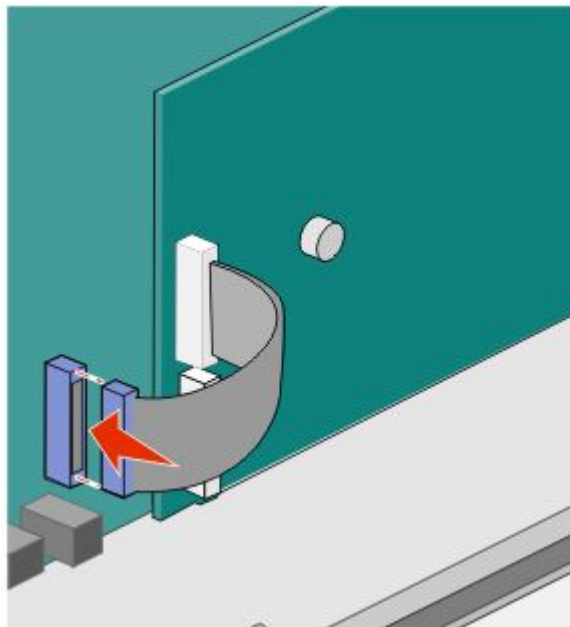

12 Reattach the system board cover.

Installing a printer hard disk

The optional printer hard disk can be installed with or without a Lexmark Internal Solutions Port (ISP).

Note: This task requires a flathead screwdriver.

CAUTION—SHOCK HAZARD: If you are installing an Internal Solutions Port (ISP) after setting up the printer, then turn the printer off and unplug the power cord from the wall outlet before continuing.

Warning—Potential Damage: System board electronic components are easily damaged by static electricity. Touch something metal on the printer before touching any system board electronic components or connectors.

- 1 Access the system board.
- 2 Unpack the printer hard disk.
Note: Avoid touching the components on the card.
- 3 Locate the appropriate connector on the system board.

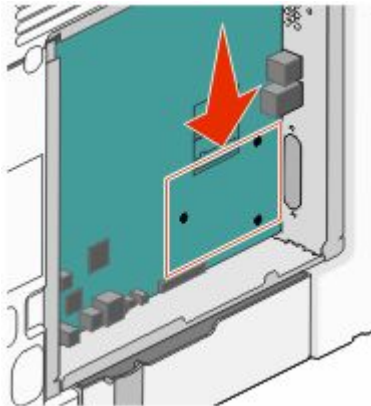

Note: If an optional ISP is currently installed, then the printer hard disk must be installed onto the ISP.

To install a printer hard disk onto the ISP:

- a Using a flathead screwdriver to loosen the screws, remove the thumbscrews that attach the printer hard disk mounting bracket to the printer hard disk, and then remove the bracket.

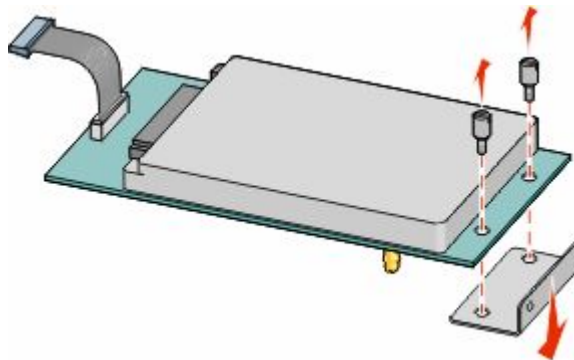

- b** Align the standoffs of the printer hard disk with the holes in the ISP, and then press downward on the printer hard disk until the standoffs have seated into place.

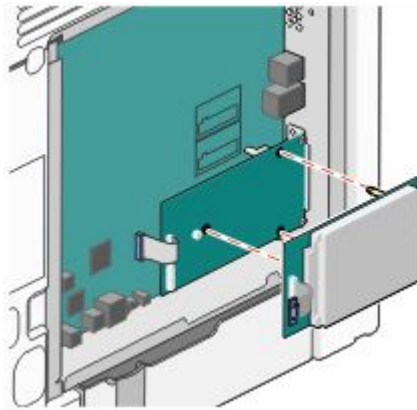

- c** Insert the plug of the printer hard disk interface cable into the receptacle of the ISP.

Note: The plugs and receptacles are color-coded.

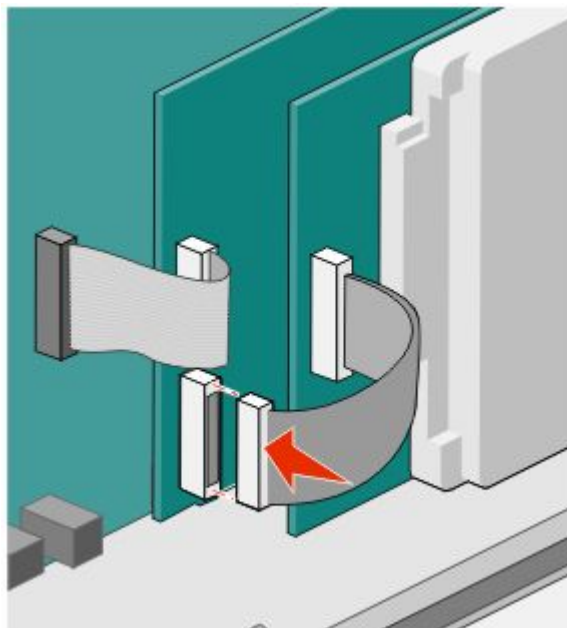

To install a printer hard disk directly on the system board:

- a** Align the standoffs of the printer hard disk with the holes in the system board, and then press downward on the printer hard disk until the standoffs have seated into place.

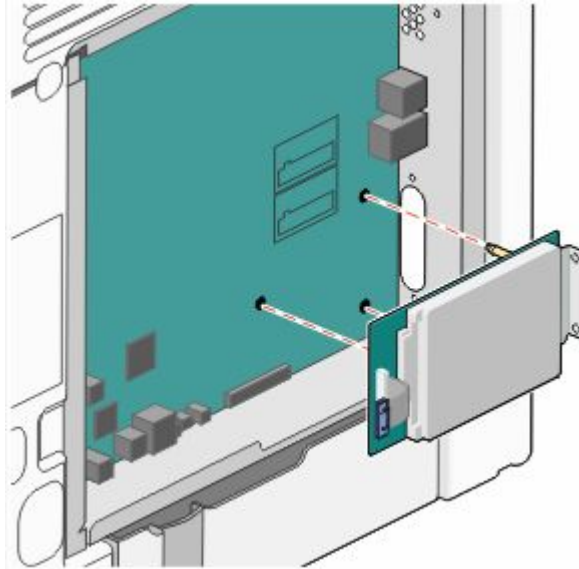

- b** Attach the two provided screws to secure the printer hard disk mounting bracket.

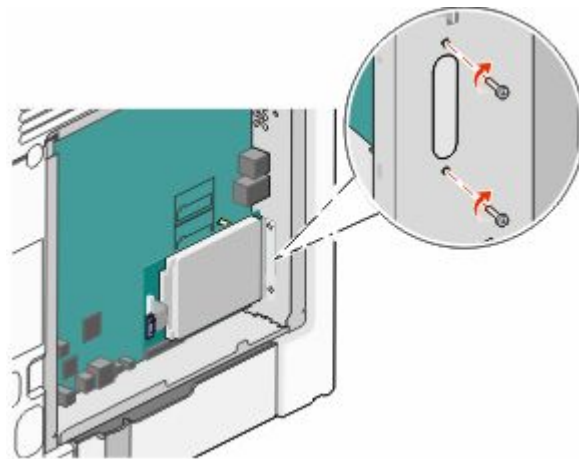

- c** Insert the plug of the printer hard disk interface cable into the receptacle of the system board.

Note: The plugs and receptacles are color-coded.

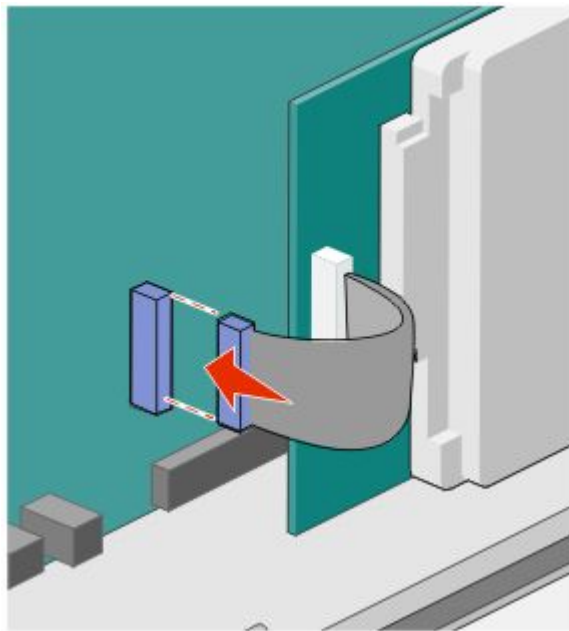

4 Reattach the system board cover.

Reattaching the system board cover

Warning—Potential Damage: System board electrical components are easily damaged by static electricity. Touch something metal on the printer before touching any system board electronic components or connectors.

Note: This task requires a flathead screwdriver.

1 Align the eight keyholes with the screws to replace the cover.

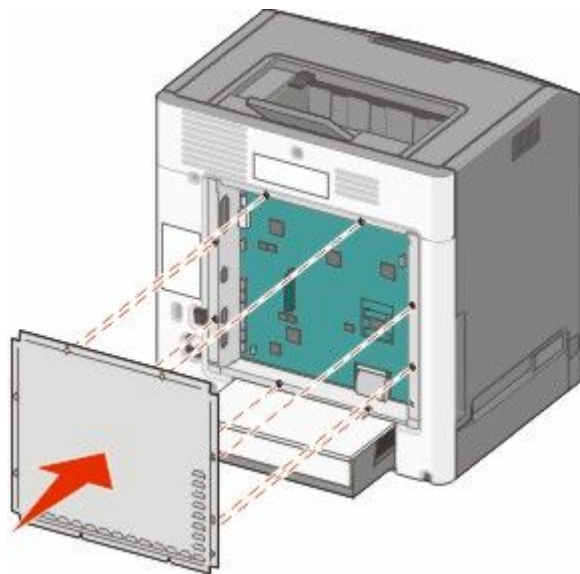

2 Slide the cover down, and then turn each screw clockwise to tighten.

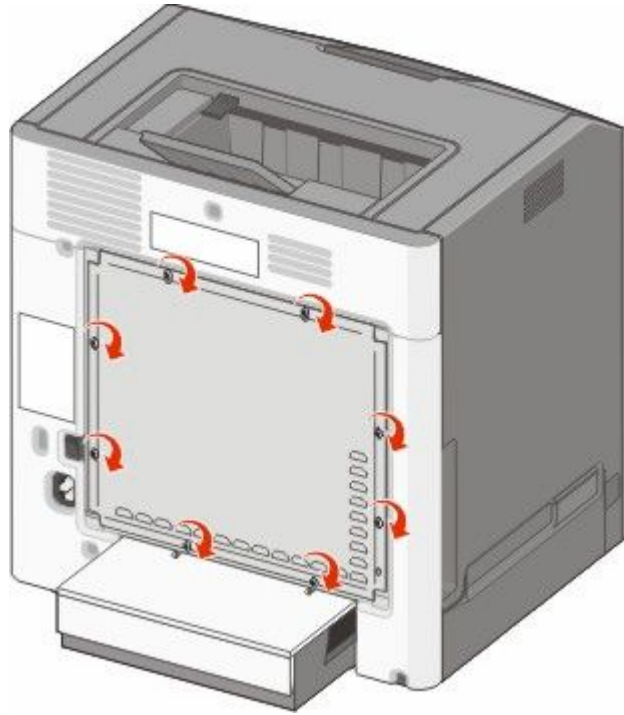

Attaching cables

Connect the printer to the computer using a USB cable or Ethernet cable.

Be sure to match the following:

- The USB symbol on the cable with the USB symbol on the printer
- The appropriate Ethernet cable to the Ethernet port

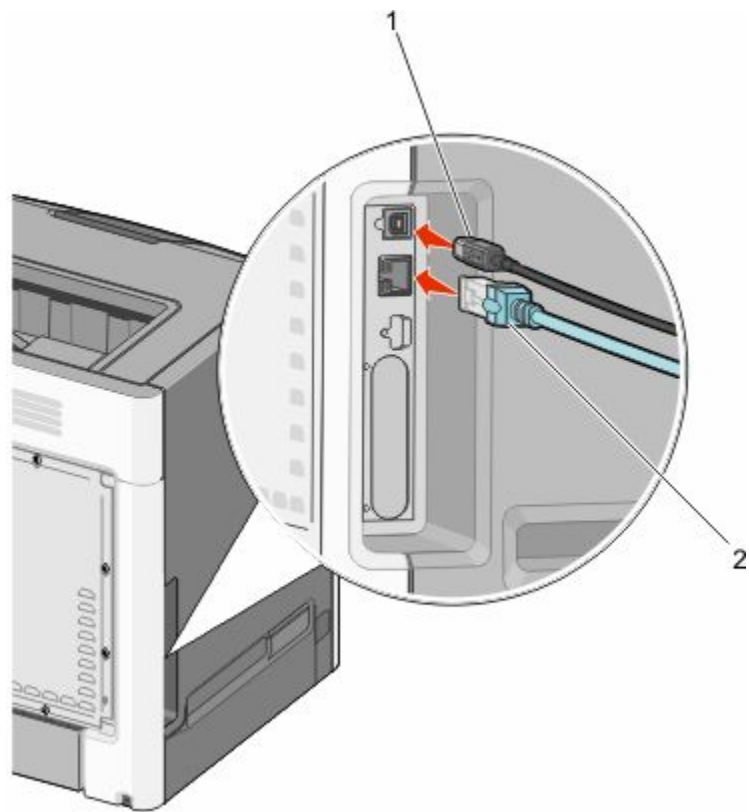

1	USB port
2	Ethernet port

Installing optional trays

The printer supports up to three optional input sources: an optional 550-sheet tray, an optional 2,000-sheet tray, and an optional 550-sheet specialty media drawer. Instructions for installing an optional input source are the same for each.

 **CAUTION—TIPPING HAZARD:** Floor-mounted configurations require additional furniture for stability. You must use either a printer stand or printer base if you are using a high-capacity input tray, a duplex unit and an input option, or more than one input option. If you purchased a multifunction printer (MFP) that scans, copies, and faxes, you may need additional furniture. For more information, see www.lexmark.com/multifunctionprinters.

Note: The C736n, C736dn, and C736dtn model printers support a total of four optional input sources. The C734n, C734dn, C734dtn, and C734dnw model printers support a total of three optional input sources.

 **CAUTION—POTENTIAL INJURY:** The printer weight is greater than 18 kg (40 lb) and requires two or more trained personnel to lift it safely.

 **CAUTION—SHOCK HAZARD:** If you are installing an optional tray after setting up the printer, then turn the printer off and unplug the power cord, the USB cable, and the Ethernet cable before continuing.

- 1 Unpack the optional tray, and remove all packing material.
- 2 Place the tray in the location chosen for the printer.

Note: If you are installing more than one optional tray, the 2,000-sheet tray must always be installed as the first optional tray (configuring from the bottom up).

Note: The optional 550-sheet tray and the optional 550-sheet specialty media drawer are interchangeable.

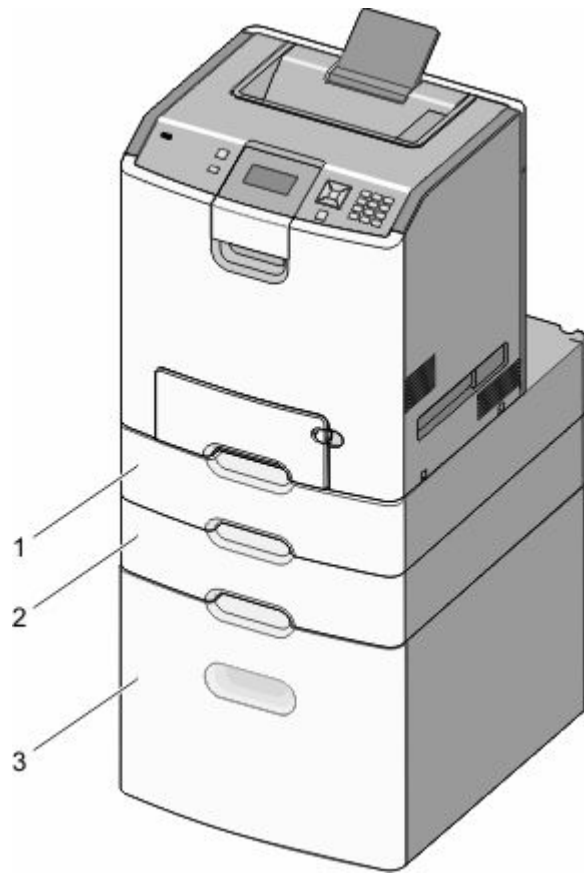

1	Optional 550-sheet tray (or optional 550-sheet specialty media drawer)
2	Optional 550-sheet specialty media drawer (or optional 550-sheet tray)
3	Optional 2,000-sheet tray

Note: Optional trays lock together when stacked. Remove stacked trays one at a time from the top down.

3 Align the printer with the tray, and then lower the printer into place.

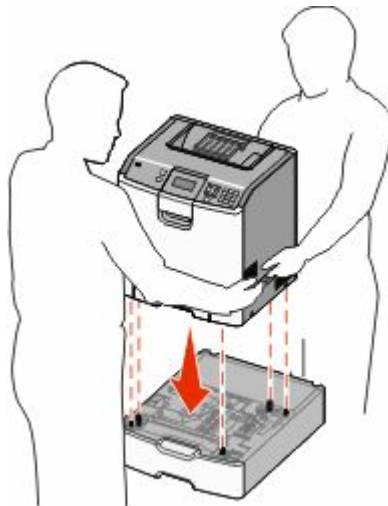

Verifying printer setup

Printing a menu settings page

Print a menu settings page to review the status of the supplies.

- 1 Make sure the printer is on and **Ready** appears.
- 2 From the printer control panel, press .
- 3 Press the down arrow button until **Reports** appears, and then press .
- 4 Press to select **Menu Settings Page**.

Printing Menu Settings Page appears. After the menu settings page prints, **Ready** appears.

Printing a network setup page

If the printer is attached to a network, print a network setup page to verify the network connection. This page also provides important information that aids network printing configuration.

- 1 Make sure the printer is on and **Ready** appears.
- 2 From the printer control panel, press .
- 3 Press the down arrow button until **Reports** appears, and then press .
- 4 Press the down arrow button until **Network Setup Page** appears, and then press .

After the network setup page prints, **Ready** appears.

- 5 Check the first section on the network setup page, and confirm that Status is "Connected."

If Status is "Not Connected," the LAN drop may not be active, the network cable may be malfunctioning, or, if you have a wireless printer model, the wireless network may not be configured properly. Consult a system support person for a solution, and then print another network setup page.

Setting up the printer software

Installing printer software

A printer driver is software that lets the computer communicate with the printer. The printer software is typically installed during the initial printer setup. If you need to install the software after setup, follow these instructions:

For Windows users

- 1 Close all open software programs.
- 2 Insert the *Software and Documentation* CD.
- 3 From the main installation dialog, click **Install**.
- 4 Follow the instructions on the screen.

For Macintosh users

- 1 Close all open software applications.
- 2 Insert the *Software and Documentation* CD.
- 3 From the Finder desktop, double-click the printer CD icon that automatically appears.
- 4 Double-click the **Install** icon.
- 5 Follow the instructions on the screen.

Using the World Wide Web

- 1 Go to the Lexmark Web site at **www.lexmark.com**.
- 2 From the Drivers & Downloads menu, click **Driver Finder**.
- 3 Select your printer, and then select your operating system.
- 4 Download the driver and install the printer software.

Updating available options in the printer driver

Once the printer software and any options are installed, it may be necessary to manually add the options in the printer driver to make them available for print jobs.

For Windows users

- 1 Click , or click **Start** and then click **Run**.
- 2 In the Start Search or Run box, type **control printers**.
- 3 Press **Enter**, or click **OK**.
The printer folder opens.
- 4 Select the printer.
- 5 Right-click the printer, and then select **Properties**.
- 6 Click the **Install Options** tab.
- 7 Under Available Options, add any installed hardware options.
- 8 Click **Apply**.

For Macintosh users

In Mac OS X version 10.5 or later

- 1 From the Apple menu, choose **System Preferences**.
- 2 Click **Print & Fax**.
- 3 Select the printer, and then click **Options & Supplies**.
- 4 Click **Driver**, and then add any installed hardware options.
- 5 Click **OK**.

In Mac OS X version 10.4 and earlier

- 1 From the Finder desktop, choose **Go > Applications**.
- 2 Double-click **Utilities**, and then double-click **Print Center** or **Printer Setup Utility**.
- 3 Select the printer, and then from the Printers menu, choose **Show Info**.
- 4 From the pop-up menu, choose **Installable Options**.
- 5 Add any installed hardware options, and then click **Apply Changes**.

Setting up wireless printing

Follow these instructions if your printer model is wireless.

Note: A Service Set Identifier (SSID) is a name assigned to a wireless network. Wireless Encryption Protocol (WEP) and Wi-Fi Protected Access (WPA) are types of security used on a network.

Information you will need to set up the printer on a wireless network

Note: Do not connect the installation or network cables until prompted to do so by the setup software.

- **SSID**—The SSID is also referred to as the network name.
- **Wireless Mode (or Network Mode)**—The mode will be either infrastructure or ad hoc.
- **Channel (for ad hoc networks)**—The channel defaults to auto for infrastructure networks.

Some ad hoc networks will also require the auto setting. Check with your system support person if you are not sure which channel to select.

- **Security Method**—There are three basic options for Security Method:

- WEP key

If your network uses more than one WEP key, enter up to four in the provided spaces. Select the key currently in use on the network by selecting the Default WEP Transmit Key.

or

- WPA or WPA2 passphrase

WPA includes encryption as an additional layer of security. The choices are AES or TKIP. Encryption must be set for the same type on the router and on the printer, or the printer will not be able to communicate on the network.

- No security

If your wireless network does not use any type of security, then you will not have any security information.

Note: Using an unsecured wireless network is not recommended.

If you are installing the printer on an 802.1X network using the Advanced method, then you may need the following:

- Authentication type
- Inner authentication type
- 802.1X username and password
- Certificates

Note: For more information on configuring 802.1X security, see the *Networking Guide on the Software and Documentation CD*.

Installing the printer on a wireless network (Windows)

Before you install the printer on a wireless network, make sure that:

- Your wireless network is set up and working properly.
- The computer you are using is connected to the same wireless network where you want to set up the printer.

1 Connect the power cable to the printer and then to a properly grounded electrical outlet, and then turn the printer on.

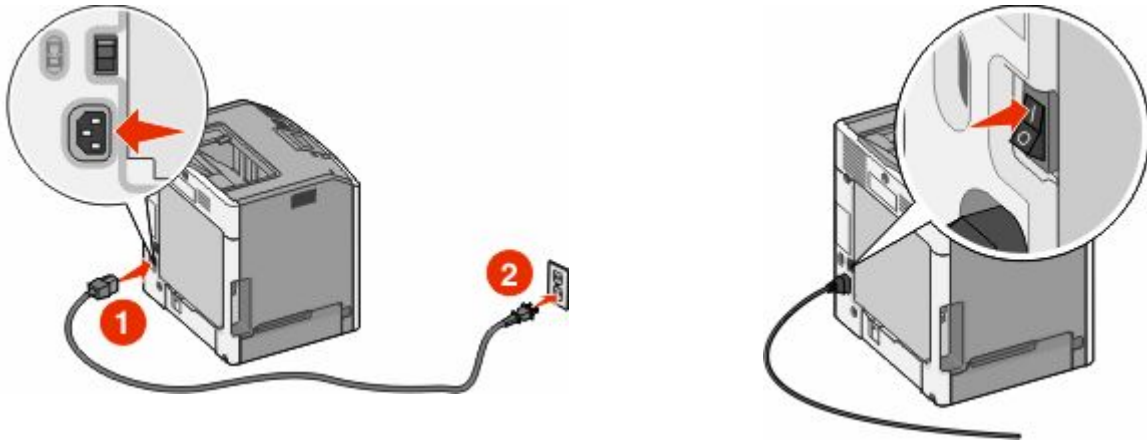

Make sure the printer and computer are fully on and ready.



Do not connect the USB cable until instructed to do so on the screen.

2 Insert the *Software and Documentation* CD.

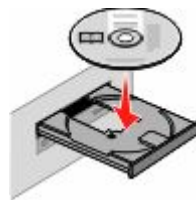

3 Click **Install Printer and Software**.

4 Click **Agree** to agree to the License Agreement.

5 Click **Suggested**, and then click **Next**.

6 Click **Wireless Network Attach**.

- 7 Temporarily connect a USB cable between the computer on the wireless network and the printer.

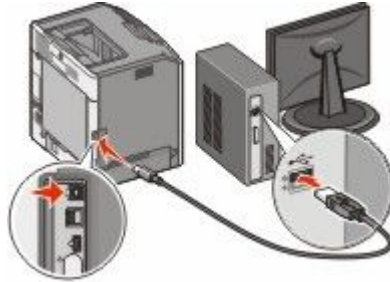

Note: After the printer is configured, the software will instruct you to disconnect the temporary USB cable so you can print wirelessly.

- 8 Follow the on-screen instructions to complete the software installation.

Note: **Basic** is the recommended path to choose. Choose **Advanced** only if you want to customize your installation.

- 9 To allow other computers on the wireless network to use the wireless printer, follow steps 2 through 6 and step 8 for each computer.

Installing the printer on a wireless network (Macintosh)

Prepare to configure the printer

- 1 Locate the printer MAC address on the sheet that shipped with the printer. Write the last six digits of the MAC address in the space provided below:

MAC address: _____

- 2 Connect the power cable to the printer and then to a properly grounded electrical outlet, and then turn the power on.

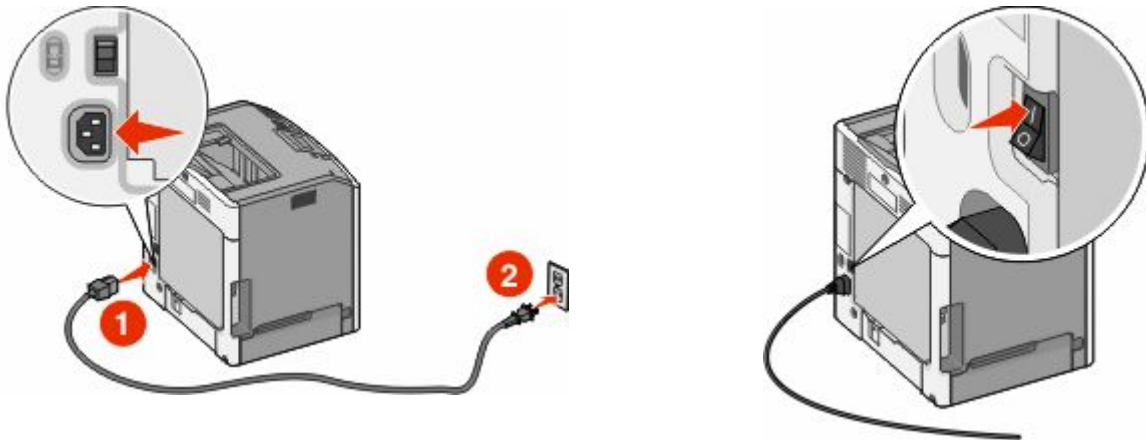

Enter the printer information

- 1 Access the AirPort options.

In Mac OS X version 10.5 or later

- a From the Apple menu, choose **System Preferences**.
- b Click **Network**.
- c Click **AirPort**.

In Mac OS X version 10.4 and earlier

- a From the Finder desktop, choose **Go > Applications**.
- b From the Applications folder, double-click **Internet Connect**.
- c From the toolbar, click **AirPort**.

2 From the Network pop-up menu, select **print server xxxxxx**, where the x's are the last six digits of the MAC address located on the MAC address sheet.

3 Open the Safari browser.

4 From the Bookmarks drop-down menu, select **Show**.

5 Under Collections, select **Bonjour** or **Rendezvous**, and then double-click the printer name.

Note: The application is referred to as Rendezvous in Mac OS X version 10.3, but is now called Bonjour by Apple Computer.

6 From the main page of the Embedded Web Server, navigate to the page where the wireless settings information is stored.

Configure the printer for wireless access

1 Type the name of your network (SSID) in the appropriate field.

2 Select **Infrastructure** as your Network Mode if you are using a wireless router.

3 Select the type of security you use to protect your wireless network.

4 Enter the security information necessary for the printer to join your wireless network.

5 Click **Submit**.

6 Open the AirPort application on your computer:

In Mac OS X version 10.5 or later

- a From the Apple menu, choose **System Preferences**.
- b Click **Network**.
- c Click **AirPort**.

In Mac OS X version 10.4 and earlier

- a From the Finder desktop, click **Go > Applications**.
- b From the Applications folder, double-click **Internet Connect**.
- c From the toolbar, click **AirPort**.

7 From the Network pop-up menu, select your wireless network.

Configure your computer to use the printer wirelessly

To print to a network printer, each Macintosh user must install a custom *PostScript Printer Description* (PPD) file and create a printer in the Print Center or Printer Setup Utility.

1 Install a PPD file on the computer:

- a Insert the *Software and Documentation* CD in the CD or DVD drive.
- b Double-click the installer package for the printer.
- c From the Welcome screen, click **Continue**.
- d Click **Continue** again after viewing the Readme file.
- e Click **Continue** after viewing the license agreement, and then click **Agree** to accept the terms of the agreement.
- f Select a Destination, and then click **Continue**.
- g From the Easy Install screen, click **Install**.
- h Type the user password, and then click **OK**.
All necessary software is installed on the computer.
- i Click **Restart** when installation is complete.

2 Add the printer:

a For IP printing:

In Mac OS X version 10.5 or later

- 1 From the Apple menu, choose **System Preferences**.
- 2 Click **Print & Fax**.
- 3 Click **+**.
- 4 Click **IP**.
- 5 Type in the IP address of your printer in the Address field.
- 6 Click **Add**.

In Mac OS X version 10.4 and earlier

- 1 From the Finder desktop, choose **Go > Applications**.
- 2 Double-click the **Utilities** folder.
- 3 Locate and double-click **Printer Setup Utility** or **Print Center**.
- 4 From the Printer List, choose **Add**.
- 5 Click **IP**.
- 6 Type in the IP address of your printer in the Address field.
- 7 Click **Add**.

b For AppleTalk printing:

In Mac OS X version 10.5

- 1 From the Apple menu, choose **System Preferences**.
- 2 Click **Print & Fax**.
- 3 Click **+**.
- 4 Click **AppleTalk**.
- 5 Select the printer from the list.
- 6 Click **Add**.

In Mac OS X version 10.4

- 1 From the Finder desktop, choose **Go > Applications**.
- 2 Double-click the **Utilities** folder.
- 3 Locate and double-click **Print Center** or **Printer Setup Utility**.
- 4 From the Printer List, choose **Add**.
- 5 Choose the **Default Browser** tab.
- 6 Click **More Printers**.
- 7 From the first pop-up menu, choose **AppleTalk**.
- 8 From the second pop-up menu, select **Local AppleTalk zone**.
- 9 Select the printer from the list.
- 10 Click **Add**.

Installing the printer on a wired network

Use the following instructions to install the printer on a wired network. These instructions apply to Ethernet and fiber optic network connections.

Before you install the printer on a wired network, make sure that:

- You have completed the initial setup of the printer.
- The printer is connected to your network with the appropriate type of cable.

For Windows users

- 1 Insert the *Software and Documentation* CD.

Wait for the Welcome screen to appear.

If the CD does not launch after a minute, then do the following:

- a Click , or click **Start** and then click **Run**.
- b In the Start Search or Run box, type `D:\setup.exe`, where **D** is the letter of your CD or DVD drive.

- 2 Click **Install Printer and Software**.
- 3 Click **Agree** to agree to the License Agreement.
- 4 Select **Suggested**, and then click **Next**.

Note: To configure the printer using a static IP address, using IPv6, or to configure printers using scripts, select **Custom** and follow the on-screen instructions.

- 5 Select **Wired Network Attach**, and then click **Next**.
- 6 Select the printer manufacturer from the list.
- 7 Select the printer model from the list, and then click **Next**.
- 8 Select the printer from the list of printers discovered on the network, and then click **Finish**.

Note: If your configured printer does not appear in the list of discovered printers, click **Add Port** and follow the on-screen instructions.

- 9 Follow the on-screen instructions to complete the installation.

For Macintosh users

- 1 Allow the network DHCP server to assign an IP address to the printer.
- 2 Print the network setup page from the printer. For information on printing a network setup page, see “Printing a network setup page” on page 37.
- 3 Locate the printer IP address in the TCP/IP section of the network setup page. You will need the IP address if you are configuring access for computers on a different subnet than the printer.
- 4 Install the drivers and add the printer.
 - a Install a PPD file on the computer:
 - 1 Insert the *Software and Documentation* CD in the CD or DVD drive.
 - 2 Double-click the installer package for the printer.
 - 3 From the Welcome screen, click **Continue**.
 - 4 Click **Continue** again after viewing the Readme file.
 - 5 Click **Continue** after viewing the license agreement, and then click **Agree** to accept the terms of the agreement.
 - 6 Select a Destination, and then click **Continue**.
 - 7 From the Easy Install screen, click **Install**.
 - 8 Type the user password, and then click **OK**.
All the necessary software is installed on the computer.
 - 9 Click **Restart** when installation is complete.
 - b Add the printer:
 - For IP printing:

In Mac OS X version 10.5 or later

- 1 From the Apple menu, choose **System Preferences**.
- 2 Click **Print & Fax**.
- 3 Click +.
- 4 Click **IP**.
- 5 Type in the IP address of your printer in the Address field.
- 6 Click **Add**.

In Mac OS X version 10.4 and earlier

- 1 From the Finder desktop, choose **Go > Applications**.
 - 2 Double-click **Utilities**.
 - 3 Double-click **Printer Setup Utility** or **Print Center**.
 - 4 From the Printer List, click **Add**.
 - 5 Click **IP**.
 - 6 Type in the IP address of your printer in the Address field.
 - 7 Click **Add**.
- For AppleTalk printing:

In Mac OS X version 10.5

- 1 From the Apple menu, choose **System Preferences**.
- 2 Click **Print & Fax**.

- 3 Click **+**.
- 4 Click **AppleTalk**.
- 5 Select the printer from the list.
- 6 Click **Add**.

In Mac OS X version 10.4 and earlier

- 1 From the Finder desktop, choose **Go > Applications**.
- 2 Double-click **Utilities**.
- 3 Double-click **Print Center** or **Printer Setup Utility**.
- 4 From the Printer List, click **Add**.
- 5 Choose the **Default Browser** tab.
- 6 Click **More Printers**.
- 7 From the first pop-up menu, choose **AppleTalk**.
- 8 From the second pop-up menu, select **Local AppleTalk zone**.
- 9 Select the printer from the list.
- 10 Click **Add**.

Note: If the printer doesn't show up in the list, you may need to add it using the IP address. Contact your system support person for assistance.

Changing port settings after installing a new network Internal Solutions Port

When a new network Lexmark Internal Solutions Port (ISP) is installed in the printer, the printer configurations on computers that access the printer must be updated because the printer will be assigned a new IP address. All computers that access the printer must be updated with this new IP address in order to print to it over the network.

Notes:

- If the printer has a static IP address that will stay the same, then you do not need to make any changes to the computer configurations.
- If the computers are configured to print to the printer by a network name that will stay the same, instead of by IP address, then you do not need to make any changes to the computer configurations.
- If you are adding a wireless ISP to a printer previously configured for a wired connection, then make sure the wired network is disconnected when you configure the printer to operate wirelessly. If the wired connection remains connected, then the wireless configuration will complete, but the wireless ISP will not be active. In the event that the printer was configured for a wireless ISP while still attached to a wired connection, disconnect the wired connection, turn the printer off, and then turn the printer back on again. This will enable the wireless ISP.
- Only one network connection at a time is active. If you want to switch the connection type between wired and wireless, you must first turn the printer off, connect the cable (to switch to a wired connection) or disconnect the cable (to switch to a wireless connection), and then turn the printer back on again.

For Windows users

- 1 Print a network setup page and make a note of the new IP address.
- 2 Click , or click **Start** and then click **Run**.

- 3** In the Start Search or Run box, type **control printers**.
- 4** Press **Enter**, or click **OK**.
The printer folder opens.
- 5** Locate the printer that has changed.
Note: If there is more than one copy of the printer, then update all of them with the new IP address.
- 6** Right-click the printer.
- 7** Click **Properties**.
- 8** Click the **Ports** tab.
- 9** Locate the port in the list, and then select it.
- 10** Click **Configure Port**.
- 11** Type the new IP address in the "Printer Name or IP Address" field. You can find the new IP address on the network setup page you printed in step 1.
- 12** Click **OK**, and then click **Close**.

For Macintosh users

- 1** Print a network setup page and make a note of the new IP address.
- 2** Locate the printer IP address in the TCP/IP section of the network setup page. You will need the IP address if you are configuring access for computers on a different subnet than the printer.
- 3** Add the printer:
 - For IP printing:

In Mac OS X version 10.5 or later

- a** From the Apple menu, choose **System Preferences**.
- b** Click **Print & Fax**.
- c** Click **+**.
- d** Click **IP**.
- e** Type in the IP address of your printer in the Address field.
- f** Click **Add**.

In Mac OS X version 10.4 and earlier

- a** From the Go menu, choose **Applications**.
 - b** Double-click **Utilities**.
 - c** Double-click **Printer Setup Utility** or **Print Center**.
 - d** From the Printer List, click **Add**.
 - e** Click **IP**.
 - f** Type in the IP address of your printer in the Address field.
 - g** Click **Add**.
- For AppleTalk printing:

In Mac OS X version 10.5

- a From the Apple menu, choose **System Preferences**.
- b Click **Print & Fax**.
- c Click **+**.
- d Click **AppleTalk**.
- e Select the printer from the list.
- f Click **Add**.

In Mac OS X version 10.4 and earlier

- a From the Go menu, choose **Applications**.
- b Double-click **Utilities**.
- c Double-click **Print Center** or **Printer Setup Utility**.
- d From the Printer List, click **Add**.
- e Choose the **Default Browser** tab.
- f Click **More Printers**.
- g From the first pop-up menu, choose **AppleTalk**.
- h From the second pop-up menu, select **Local AppleTalk zone**.
- i Select the printer from the list.
- j Click **Add**.

Setting up serial printing

In serial printing, data is transferred one bit at a time. Although serial printing is usually slower than parallel printing, it is the preferred option when there is a great deal of distance between the printer and computer or when an interface with a better transfer rate is not available.

After installing the serial port, you will need to configure the printer and the computer so they can communicate. Make sure you have connected the serial cable to the serial port on your printer.

1 Set the parameters in the printer:

- a From the printer control panel, navigate to the menu with port settings.
- b Locate the submenu with serial port settings.
- c Make any necessary changes to the serial settings.
- d Save the new settings.
- e Print a menu settings page.

2 Install the printer driver:

- a Insert the *Software and Documentation* CD. It launches automatically.
If the CD does not launch automatically, then do the following:
 - 1 Click , or click **Start** and then click **Run**.
 - 2 In the Start Search or Run box, type `D:\setup.exe`, where **D** is the letter of your CD or DVD drive.
- b Click **Install Printer and Software**.
- c Click **Agree** to accept the Printer Software License Agreement.
- d Click **Custom**.
- e Make sure **Select Components** is selected, and then click **Next**.

- f** Make sure Local is selected, and then click **Next**.
 - g** Select the manufacturer of the printer from the menu.
 - h** Select the printer model from the menu, and then click **Add Printer**.
 - i** Click the + beside the printer model under Select Components.
 - j** Make sure the correct port is available under Select Components. This is the port where the serial cable attaches to the computer. If the correct port is not available, select the port under the Select Port menu, and then click **Add Port**.
 - k** Make any configuration changes necessary in the Add a New Port window. Click **Add Port** to finish adding the port.
 - l** Make sure the box next to the selected printer model is checked.
 - m** Select any other optional software you want to install, and then click **Next**.
 - n** Click **Finish** to complete the printer software installation.
- 3** Set the COM port parameters:

After the printer driver is installed, you must set the serial parameters in the communications (COM) port assigned to the printer driver.

The serial parameters in the COM port must match the serial parameters you set in the printer.

- a** Open the Device Manager.
 - 1** Click , or click **Start** and then click **Run**.
 - 2** In the Start Search or Run box, type `devmgmt . msc`.
 - 3** Press **Enter**, or click **OK**.
The Device Manager opens.
- b** Click + to expand the list of available ports.
- c** Select the communications port where you attached the serial cable to your computer (example: COM1).
- d** Click **Properties**.
- e** On the Port Settings tab, set the serial parameters to the same serial parameters in the printer.
Look for the printer settings under the serial heading on the Menu Settings page you printed earlier.
- f** Click **OK**, and then close all the windows.
- g** Print a test page to verify printer installation. When a test page prints successfully, printer setup is complete.

Minimizing your printer's environmental impact

Lexmark is committed to environmental sustainability and is continually improving its printers to reduce their impact on the environment. We design with the environment in mind, engineer our packaging to reduce materials, and provide collection and recycling programs. For more information, see:

- The Notices chapter
- The Environmental Sustainability section of the Lexmark Web site at www.lexmark.com/environment
- The Lexmark recycling program at www.lexmark.com/recycle

By selecting certain printer settings or tasks, you may be able to reduce your printer's impact even further. This chapter outlines the settings and tasks that may yield a greater environmental benefit.

Saving paper and toner

Studies show that as much as 80% of the carbon footprint of a printer is related to paper usage. You can significantly reduce your carbon footprint by using recycled paper and the following printing suggestions, such as printing on both sides of the paper and printing multiple pages on one side of a single sheet of paper.

For information on how you can quickly save paper and energy using one printer setting, see "Using Eco-Mode".

Using recycled paper

As an environmentally conscious company, Lexmark supports the use of recycled office paper produced specifically for use in laser printers. For more information on recycled papers that work well with your printer, see "Using recycled paper and other office papers" on page 65.

Conserving supplies

There are a number of ways you can reduce the amount of paper and toner you use when printing. You can:

Use both sides of the paper

If your printer model supports duplex printing, you can control whether print appears on one or two sides of the paper for a printed document by selecting **2-sided printing** from the Print dialog or the Lexmark Toolbar.

Place multiple pages on one sheet of paper

You can print up to 16 consecutive pages of a multiple-page document onto one side of a single sheet of paper by selecting a setting from the Multipage printing (N-Up) section of the Print dialog screen.

Check your first draft for accuracy

Before printing or making multiple copies of a document:

- Use the Lexmark preview feature, which you can select from the Print dialog or the Lexmark Toolbar to see what the document will look like before you print it.
- Print one copy of the document to check its content and format for accuracy.

Avoid paper jams

Carefully select and load paper to avoid paper jams. For more information, see “Avoiding jams” on page 80.

Print in black and white

To print all text and graphics using only the black toner cartridge, set the printer to Black Only. For more information, see “Printing in black and white” on page 78.

Use Max Speed or Max Yield settings

The Max Speed and Max Yield settings let you choose between a faster print speed or a higher toner yield. Max Yield is the factory default setting. For more information, see “Using Max Speed and Max Yield” on page 79.

Saving energy





Using Eco-Mode

Use Eco-Mode to quickly select one or more ways to reduce your printer's environmental impact.

Note: See the table for the multiple settings that change when you select an Eco-Mode setting.

Choose	To
Energy	Reduce energy use, especially when the printer is idle. <ul style="list-style-type: none">• Printer engine motors do not start until a job is ready to print. You may notice a short delay before the first page is printed.• The printer enters Power Saver mode after one minute of inactivity.• When the printer enters Power Saver mode, the printer control panel display light is turned off.
Paper	<ul style="list-style-type: none">• Enable the automatic duplex feature (on printer models that support duplex).• Turn off print log features.
Energy/Paper	Use all the settings associated with Energy mode and Paper mode.
Off	Use factory default settings for all settings associated with Eco-Mode. This setting supports the performance specifications for your printer.

To select an Eco-Mode setting:

- 1 Make sure that the printer is on and **Ready** appears.
- 2 From the printer control panel, press .
- 3 Press the down arrow button until **Settings** appears, and then press .
- 4 Press the down arrow button until **General Settings** appears, and then press .
- 5 Press the down arrow button until **Eco-Mode** appears, and then press .
- 6 Press the left or right arrow button to scroll through the list of possible settings. Press  at the correct setting. **Submitting Selection** appears.

Reducing printer noise

Use Quiet Mode to reduce the printer noise.

Note: See the table for the multiple settings that change when you select a Quiet Mode setting.

Choose	To
On (Text/Graphics) Note: This setting is best suited for printing text and line graphics.	Reduce printer noise. <ul style="list-style-type: none">• Print jobs will process at one-half the normal processing speed.• Printer engine motors do not start until a job is ready to print. There will be a short delay before the first page is printed.• Fans run at reduced speed or are turned off.• If your printer has faxing capability, fax sounds are reduced or disabled, including those made by the fax speaker and ringer. The fax is placed in standby mode.• The alarm control and cartridge alarm sounds are turned off.• The printer will ignore the Advance Start command.
Off (Image/Photo) Note: Selecting Photo from the driver may disable Quiet Mode and provide better print quality and full speed printing.	Use factory default settings. This setting supports the performance specifications for your printer.

To select a Quiet Mode setting:

- 1 Make sure that the printer is on and **Ready** appears.
- 2 From the printer control panel, press .
- 3 Press the down arrow button until **Settings** appears, and then press .
- 4 Press the down arrow button until **General Settings** appears, and then press .
- 5 Press the down arrow button until **Quiet Mode** appears, and then press .
- 6 Press the left or right arrow button to scroll through the list of possible settings. Press at the correct setting. **Submitting Selection** appears.

Adjusting Power Saver

To save energy, you can decrease the number of minutes before the printer enters Power Saver mode.

Available settings range from 1–240 minutes. The factory default setting is 30 minutes.

Using the Embedded Web Server

- 1 Type the printer IP address into the address field of your Web browser.
Note: If you do not know the IP address of the printer, then print a network setup page and locate the IP address in the TCP/IP section.
- 2 Click **Settings**, and then click **General Settings**.

3 Click **Timeouts**.

4 In the Power Saver box, increase or decrease the number of minutes you want the printer to wait before it enters Power Saver mode.

5 Click **Submit**.

Using the printer control panel

1 Make sure the printer is on and **Ready** appears.

2 Press .

3 Press the arrow buttons until **Settings** appears, and then press .

4 Press the arrow buttons until **General Settings** appears, and then press .

5 Press the arrow buttons until **Timeouts** appears, and then press .

6 Press the arrow buttons until **Power Saver** appears, and then press .

7 Press the arrow buttons to increase or decrease the number of minutes before the printer enters Power Saver mode, and then press .

Adjusting the brightness of the display

To save energy, or if you are having trouble reading your display, you can adjust the brightness of the display.

Available settings range from 1–10. The factory default setting is 5.

Using the Embedded Web Server

1 Type the printer IP address into the address field of your Web browser.

Note: If you do not know the IP address of the printer, then print a network setup page and locate the IP address in the TCP/IP section.

2 Click **Settings**, and then click **Utilities Menu**.

3 In the LCD Brightness box, type in the brightness you want for your display.

4 Click **Submit**.

Using the printer control panel

1 Make sure the printer is on and **Ready** appears.

2 Press .

3 Press the arrow buttons until **Settings** appears, and then press .

4 Press the arrow buttons until **Utilities Menu** appears, and then press .

5 Press the arrow buttons until **LCD Brightness** appears, and then press .

6 Press the arrow buttons to select a setting, and then press .

Recycling

Lexmark provides collection programs and environmentally progressive approaches to recycling. For more information, see:

- The Notices chapter
- The Environmental Sustainability section of the Lexmark Web site at www.lexmark.com/environment
- The Lexmark recycling program at www.lexmark.com/recycle

Recycling Lexmark products

To return Lexmark products to Lexmark for recycling:

- 1 Visit our Web site at www.lexmark.com/recycle.
- 2 Find the product type you want to recycle, and then select your country from the list.
- 3 Follow the instructions on the computer screen.

Recycling Lexmark packaging

Lexmark continually strives to minimize packaging. Less packaging helps to ensure that Lexmark printers are transported in the most efficient and environmentally sensitive manner and that there is less packaging to dispose of. These efficiencies result in fewer greenhouse emissions, energy savings, and natural resource savings.

Lexmark cartons are 100% recyclable where corrugated recycling facilities exist. Facilities may not exist in your area.

The foam used in Lexmark packaging is recyclable where foam recycling facilities exist. Facilities may not exist in your area.

When you return a cartridge to Lexmark, you can reuse the box that the cartridge came in. Lexmark will recycle the box.

Returning Lexmark cartridges for reuse or recycling

The Lexmark Cartridge Collection Program diverts millions of Lexmark cartridges from landfills annually by making it both easy and free for Lexmark customers to return used cartridges to Lexmark for reuse or recycling. One hundred percent of the empty cartridges returned to Lexmark are either reused or demanufactured for recycling. Boxes used to return the cartridges are also recycled.

To return Lexmark cartridges for reuse or recycling, follow the instructions that came with your printer or cartridge and use the pre-paid shipping label. You can also:

- 1 Visit our Web site at www.lexmark.com/recycle.
- 2 From the Toner Cartridges section, select your country from the list.
- 3 Follow the instructions on the computer screen.







Loading paper and specialty media

This section explains how to load the standard tray (Tray 1), also known as the 550-sheet tray, an optional 550-sheet tray, an optional 2,000-sheet tray, a multipurpose tray, and an optional 550-sheet specialty media drawer. It also includes information about paper orientation, setting the Paper Size and Paper Type, and linking and unlinking trays.

Setting the paper size and type

Note: Trays with matching paper size and paper type settings are automatically linked by the printer. When a linked tray runs out of paper, the printer draws from another tray.

To change the paper size and type settings:

- 1 Make sure that the printer is on and **Ready** appears.
- 2 From the printer control panel, press .
- 3 Press the down arrow button until **✓ Paper Menu** appears, and then press .
- 4 Press the down arrow button until **✓ Paper Size/Type** appears, and then press .
- 5 Press the down arrow button until the correct tray appears, and then press .
- 6 Press the down arrow button until **✓** appears next to the correct size, and then press .
- 7 Press the left or right arrow button to scroll through the list of possible paper types. Press  at the correct paper type.
Submitting Selection appears. The printer returns to the **Paper Size/Type**.
- 8 Press  three times to return to the **Ready** state.

Loading the paper tray

The printer has up to five input sources to select from: the standard tray (Tray 1), also known as the 550-sheet tray, an optional 550-sheet tray, an optional 2,000-sheet tray, a multipurpose tray, and an optional 550-sheet specialty media drawer. Load the paper or specialty media used for the majority of print jobs in Tray 1. Proper paper loading prevents jams and facilitates trouble-free printing.

Note: The C736n, C736dn, and C736dtn model printers will support a total of four optional input sources. The C734n, C734dn, C734dtn, and C734dnw model printers will support a total of three optional input sources.

Do not remove trays while a job prints or while **Busy** blinks on the printer control panel. Doing so may cause a jam.

- 1 Grasp the handle, and then pull the tray out. Remove the tray completely.

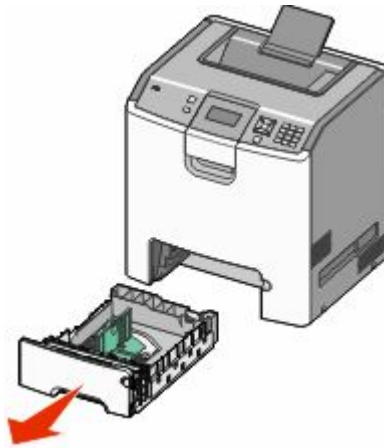

Notice the size indicators on the bottom of the tray. Use these indicators to help position the guides.

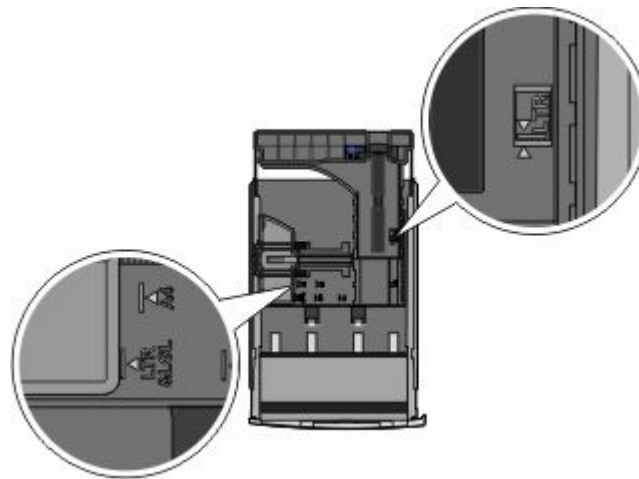

- 2 Squeeze the width guide tabs as shown, and then slide the guide to the correct position for the size of paper being loaded.

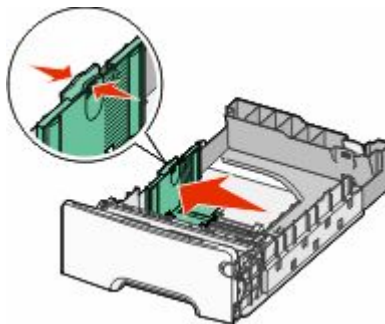

Notice the load line on the left side of the paper tray: it indicates the maximum height for loading paper.

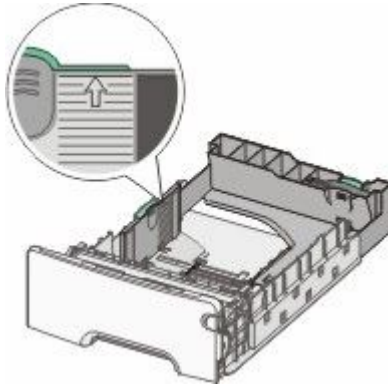

- 3 Squeeze the length guide tabs together, and then slide the length guide to the correct position for the size of paper being loaded.

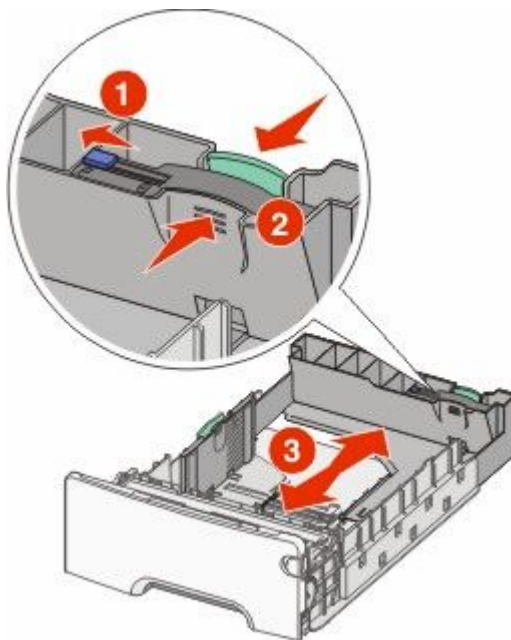

Note: The length guide has a locking device. To unlock the tray, slide the button on top of the length guide to the left as shown. To lock the tray once a length has been selected, slide the button back to the right.

- 4 Flex a stack of paper back and forth to loosen the sheets, and then fan them. Do not fold or crease the paper. Straighten the edges on a level surface.



- 5 Load the paper stack with the recommended print side faceup. Load the stack toward the back of the tray as shown.

When loading preprinted letterhead for simplex printing, place the header toward the front of the tray.

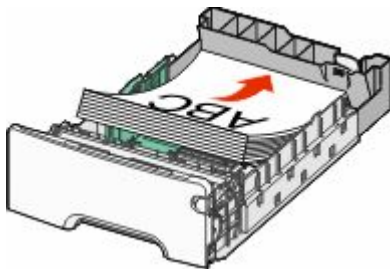

6 Align the tray, and then reinsert it.

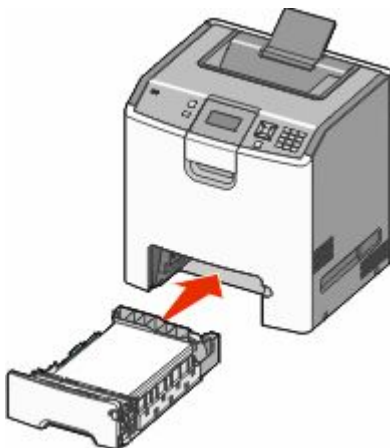

7 If a different type of paper was loaded than the type previously loaded in the tray, then change the paper type setting for the tray from the printer control panel. For more information, see “Setting the paper size and type” on page 55.

Loading the multipurpose tray

The multipurpose tray accommodates a variety of media types including envelopes. Media not kept in a tray can be loaded into the multipurpose tray.

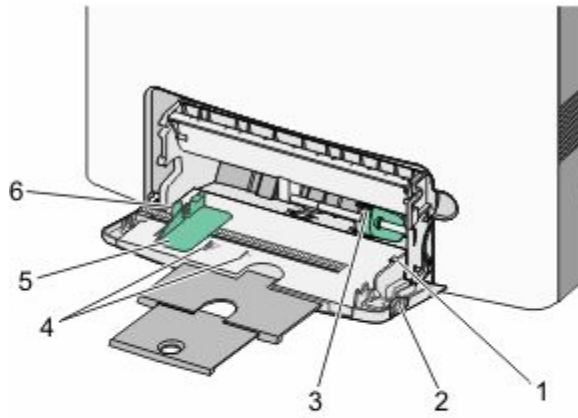

1	Stack height limiter
2	Tray release latch
3	Paper release lever
4	Size indicators
5	Width guide
6	Width guide release tab

1 Press the tray release latch to the left, and then pull the multipurpose tray down.



2 Gently pull the extension out until it is fully extended.

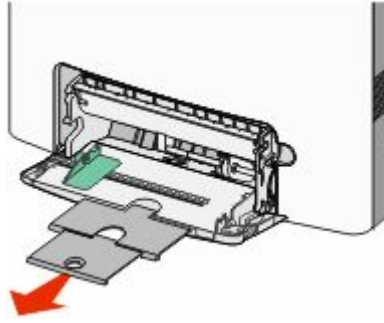

3 Prepare a media stack for loading.

- Flex sheets of paper back and forth to loosen them, and then fan them. Do not fold or crease the paper. Straighten the edges on a level surface.



- Hold transparencies by the edges, and then fan them. Straighten the edges on a level surface.

Note: Avoid touching the print side of the transparencies. Be careful not to scratch them.



- Flex a stack of envelopes back and forth to loosen them, and then fan them. Straighten the edges on a level surface.



- 4 Load the media stack with the recommended print side facedown and the top edge entering the printer first.

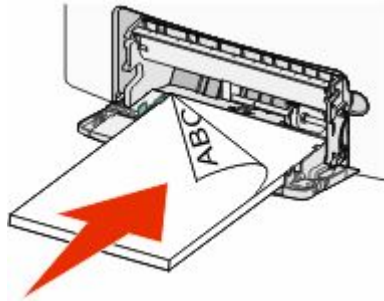

Note: Load only one size and type of media at a time.

- 5 Load envelopes with the flap side up and the return address edge entering the printer first.

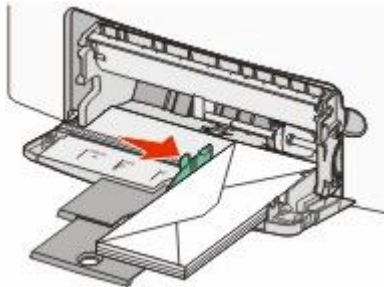

Warning—Potential Damage: Never use envelopes with stamps, clasps, snaps, windows, coated linings, or self-stick adhesives. These envelopes may severely damage the printer.

- 6 Make sure the media is as far into the multipurpose tray as it will go with very gentle pushing. Media should lie flat and fit loosely in the multipurpose tray.

Note: If the media is pushed too far into the multipurpose tray, you must press the paper release lever to remove it.

- 7 From the printer control panel, set the Paper Size and Paper Type, and then press .

The multipurpose tray can be closed when not in use.

Linking and unlinking trays

Linking trays

Tray linking is useful for large print jobs or multiple copies. When one linked tray is empty, paper feeds from the next linked tray. When the Paper Size and Paper Type settings are the same for any trays, the trays are automatically linked. The Paper Size setting is automatically sensed according to the position of the paper guides in each tray except the Standard 550-sheet tray and the multipurpose tray. The Paper Size setting for the Standard 550-sheet tray and the multipurpose tray must be set manually from the Paper Size menu. The Paper Type setting must be set for all trays from the Paper Type menu. The Paper Type menu and the Paper Size menu are both available from the Paper Size/Type menu.

Unlinking trays

Unlinked trays have settings that are *not* the same as the settings of any other tray.

To unlink a tray, change the following tray settings so that they do not match the settings of any other tray:

- Paper Type (for example: Plain Paper, Letterhead, Custom Type <x>)

Paper Type names describe the paper characteristics. If the name that best describes your paper is used by linked trays, assign a different Paper Type name to the tray, such as Custom Type <x>, or define your own custom name.

- Paper Size (for example: letter, A4, statement)

Load a different paper size to change the Paper Size setting for a tray automatically. Paper Size settings for the Standard 550-sheet tray and the multipurpose tray are not automatic; they must be set manually from the Paper Size menu.

Notes:

- Do not assign a Paper Type name that does not accurately describe the type of paper loaded in the tray. The temperature of the fuser varies according to the specified Paper Type. Paper may not be properly processed if an inaccurate Paper Type is selected.
- If the media you have loaded is smaller than the Paper Size setting, then your text or graphics may not fit on the media.

Paper and specialty media guide

Paper guidelines

Paper characteristics

The following paper characteristics affect print quality and reliability. Consider these characteristics when evaluating new paper stock.

Weight

The printer can automatically feed paper weights from 60 to 220 g/m² (16 to 58 lb bond) grain long. Paper lighter than 60 g/m² (16 lb) might not be stiff enough to feed properly, causing jams. For best performance, use 75 g/m² (20 lb bond) grain long paper. For paper smaller than 182 x 257 mm (7.2 x 10.1 in.), we recommend 90 g/m² (24 lb) or heavier paper.

Note: Duplex is supported only for 63 g/m²–120 g/m² (17 lb–32 lb bond) paper.

Curl

Curl is the tendency for paper to curl at its edges. Excessive curl can cause paper feeding problems. Curl can occur after the paper passes through the printer, where it is exposed to high temperatures. Storing paper unwrapped in hot, humid, cold, or dry conditions, even in the trays, can contribute to paper curling prior to printing and can cause feeding problems.

Smoothness

Paper smoothness directly affects print quality. If paper is too rough, toner cannot fuse to it properly. If paper is too smooth, it can cause paper feeding or print quality issues. Always use paper between 100 and 300 Sheffield points; however, smoothness between 150 and 200 Sheffield points produces the best print quality.

Moisture content

The amount of moisture in paper affects both print quality and the ability of the printer to feed the paper correctly. Leave paper in its original wrapper until it is time to use it. This limits the exposure of paper to moisture changes that can degrade its performance.

Condition paper before printing by storing it in its original wrapper in the same environment as the printer for 24 to 48 hours before printing. Extend the time several days if the storage or transportation environment is very different from the printer environment. Thick paper may also require a longer conditioning period.

Grain direction

Grain refers to the alignment of the paper fibers in a sheet of paper. Grain is either *grain long*, running the length of the paper, or *grain short*, running the width of the paper.

For 60 to 135 g/m² (16 to 36 lb bond) paper, grain long paper is recommended. For papers heavier than 135 g/m², grain short is recommended.

Fiber content

Most high-quality xerographic paper is made from 100% chemically treated pulped wood. This content provides the paper with a high degree of stability resulting in fewer paper feeding problems and better print quality. Paper containing fibers such as cotton can negatively affect paper handling.

Unacceptable paper

The following paper types are not recommended for use with the printer:

- Chemically treated papers used to make copies without carbon paper, also known as carbonless papers, carbonless copy paper (CCP), or no carbon required (NCR) paper
- Preprinted papers with chemicals that may contaminate the printer
- Preprinted papers that can be affected by the temperature in the printer fuser
- Preprinted papers that require a registration (the precise print location on the page) greater than ± 2.3 mm (± 0.9 in.), such as optical character recognition (OCR) forms

In some cases, registration can be adjusted with a software application to successfully print on these forms.

- Coated papers (erasable bond), synthetic papers, thermal papers
- Rough-edged, rough or heavily textured surface papers, or curled papers
- Recycled papers that fail EN12281:2002 (European)
- Paper weighing less than 60 g/m^2 (16 lb)
- Multiple-part forms or documents

Selecting paper

Using appropriate paper prevents jams and helps ensure trouble-free printing.

To help avoid jams and poor print quality:

- *Always* use new, undamaged paper.
- Before loading paper, know the recommended print side of the paper. This information is usually indicated on the paper package.
- *Do not* use paper that has been cut or trimmed by hand.
- *Do not* mix paper sizes, types, or weights in the same source; mixing results in jams.
- *Do not* use coated papers unless they are specifically designed for electrophotographic printing.

Selecting preprinted forms and letterhead

Use these guidelines when selecting preprinted forms and letterhead:

- Use grain long for 60 to 90 g/m^2 (16 to 24 lb) weight paper.
- Use only forms and letterhead printed using an offset lithographic or engraved printing process.
- Avoid papers with rough or heavily textured surfaces.

Use papers printed with heat-resistant inks designed for use in xerographic copiers. The ink must be able to withstand temperatures up to 190°C (374°F) without melting or releasing hazardous emissions. Use inks that are not affected by the resin in toner. Inks that are oxidation-set or oil-based generally meet these requirements; latex inks might not. When in doubt, contact the paper supplier.

Preprinted papers such as letterhead must be able to withstand temperatures up to 190°C (374°F) without melting or releasing hazardous emissions.

Using recycled paper and other office papers

As an environmentally conscious company, Lexmark supports the use of recycled office paper produced specifically for use in laser (electrophotographic) printers. In 1998, Lexmark presented to the US government a study demonstrating that recycled paper produced by major mills in the US fed as well as non-recycled paper. However, no blanket statement can be made that *all* recycled paper will feed well.

Lexmark consistently tests its printers with recycled paper (20–100% post-consumer waste) and a variety of test paper from around the world, using chamber tests for different temperature and humidity conditions. Lexmark has found no reason to discourage the use of today's recycled office papers, but generally the following property guidelines apply to recycled paper.

- Low moisture content (4–5%)
- Suitable smoothness (100–200 Sheffield units, or 140–350 Bendtsen units, European)

Note: Some much smoother papers (such as premium 24 lb laser papers, 50–90 Sheffield units) and much rougher papers (such as premium cotton papers, 200–300 Sheffield units) have been engineered to work very well in laser printers, despite surface texture. Before using these types of paper, consult your paper supplier.

- Suitable sheet-to-sheet coefficient of friction (0.4–0.6)
- Sufficient bending resistance in the direction of feed

Recycled paper, paper of lower weight (<60 g/m² [16 lb bond]) and/or lower caliper (<3.8 mils [0.1 mm]), and paper that is cut grain-short for portrait (or short-edge) fed printers may have lower bending resistance than is required for reliable paper feeding. Before using these types of paper for laser (electrophotographic) printing, consult your paper supplier. Remember that these are general guidelines only and that paper meeting these guidelines may still cause paper feeding problems in any laser printer (for example, if the paper curls excessively under normal printing conditions).

Storing paper

Use these paper storage guidelines to help avoid jams and uneven print quality:

- For best results, store paper where the temperature is 21°C (70°F) and the relative humidity is 40%. Most label manufacturers recommend printing in a temperature range of 18 to 24°C (65 to 75°F) with relative humidity between 40 and 60%.
- Store paper in cartons when possible, on a pallet or shelf, rather than on the floor.
- Store individual packages on a flat surface.
- Do not store anything on top of individual paper packages.

Supported paper sizes, types, and weights

The following tables provide information on standard and optional paper input sources and the types of paper they support.

Note: To use a paper size that is unlisted, configure a Universal Paper Size.

For more information, see the *Card Stock & Label Guide* available on the Lexmark Web site at www.lexmark.com/publications.

Supported paper sizes

Measurements apply to simplex (one-sided) printing only. For duplex (two-sided) printing, the minimum size is 139.7 x 210 mm (5.50 x 8.27 in.).

Paper size	Dimensions	Standard 550-sheet tray (Tray 1)	Optional 550-sheet tray	Optional 2,000-sheet tray	Multipurpose tray	Optional 550-sheet specialty media drawer
A4	210 x 297 mm (8.27 x 11.7 in.)	✓	✓	✓	✓	✓
A5	148 x 210 mm (5.83 x 8.27 in.)	✓	✓	X	✓	✓
A6	105 x 148 mm (4.13 x 5.83 in.)	X	X	X	✓	✓
JIS B5	182 x 257 mm (7.17 x 10.1 in.)	✓	✓	X	✓	✓
Letter	215.9 x 279.4 mm (8.5 x 11 in.)	✓	✓	✓	✓	✓
Legal	215.9 x 355.6 mm (8.5 x 14 in.)	✓	✓	✓	✓	✓
Executive	184.2 x 266.7 mm (7.25 x 10.5 in.)	✓	✓	X	✓	✓
Oficio (México)	215.9 x 340.4 mm (8.5 x 13.4 in.)	✓	✓	X	✓	✓
Folio	215.9 x 330.2 mm (8.5 x 13 in.)	✓	✓	X	✓	✓
Statement	139.7 x 215.9 mm (5.5 x 8.5 in.)	X	X	X	✓	✓

*This size setting formats the envelope for 215.9 x 355.6 mm (8.5 x 14 in.) unless the size is specified by the software application.

**Supported by C734 model printers only.

***Supported by C736 model printers only.

Paper size	Dimensions	Standard 550-sheet tray (Tray 1)	Optional 550-sheet tray	Optional 2,000-sheet tray	Multipurpose tray	Optional 550-sheet specialty media drawer
Universal Note: Turn size sensing off to support universal sizes that are close to standard media sizes.	148 x 210 mm to 215.9 x 355.6 mm (5.83 x 8.27 in. to 8.5 x 14 in.)	✓	✓	X	✓	✓
	76.2 x 127 mm (3 x 5 in.) to 215.9 x 355.6 mm (8.5 x 14 in.)	X	X	X	✓	✓
	76.2 x 127 mm (3 x 5 in.) to 215.9 x 914.4 mm (8.5 x 36 in.)**	X	X	X	✓	X
	76.2 x 127 mm (3 x 5 in.) to 215.9 x 1219.2 mm (8.5 x 48 in.)***	X	X	X	✓	X
7 3/4 Envelope (Monarch)	98.4 x 190.5 mm (3.875 x 7.5 in.)	X	X	X	✓	✓
9 Envelope	98.4 x 226.1 mm (3.875 x 8.9 in.)	X	X	X	✓	✓
Com 10 Envelope	104.8 x 241.3 mm (4.12 x 9.5 in.)	X	X	X	✓	✓
DL Envelope	110 x 220 mm (4.33 x 8.66 in.)	X	X	X	✓	✓
C5 Envelope	162 x 229 mm (6.38 x 9.01 in.)	X	X	X	✓	✓
B5 Envelope	176 x 250 mm (6.93 x 9.84 in.)	X	X	X	✓	✓
Other Envelope*	85.7 x 165 mm to 215.9 x 355.6 mm (3.375 x 6.50 in. to 8.5 x 14 in.)	X	X	X	✓	✓

*This size setting formats the envelope for 215.9 x 355.6 mm (8.5 x 14 in.) unless the size is specified by the software application.

**Supported by C734 model printers only.

***Supported by C736 model printers only.

Supported paper types and weights

The printer engine supports 60–220 g/m² (16–58 lb) paper weights.

Note: Labels, transparencies, envelopes, and card stock always print at reduced speed.

Paper type	Standard 550-sheet tray (Tray 1)	Optional 550-sheet tray	Optional 2,000-sheet tray	Multipurpose tray	Optional 550-sheet specialty media drawer
Paper	✓	✓	✓	✓	✓
Card stock	✓	✓	X	✓	✓
Transparencies*	✓	✓	X	✓	✓
Labels	✓	✓	X	✓	✓
Glossy paper	✓	✓	X	✓	✓
Envelopes	X	X	X	✓	✓

* Do not use inkjet or 3M CG3710 transparencies.

Printing

This chapter covers printing, printer reports, and job cancelation. The selection and handling of paper and specialty media can affect how reliably documents print. For more information, see "Avoiding jams" and "Storing paper."

Printing a document

Printing a document

- 1 From the printer control panel Paper menu, set the Paper Type and Paper Size to match the loaded paper.
- 2 Send the print job:

For Windows users

- a With a document open, click **File → Print**.
- b Click **Properties, Preferences, Options, or Setup**, and then adjust the settings as needed.
Note: To print on a specific size or type of paper, adjust the paper size or type settings to match the loaded paper, or select the appropriate tray or feeder.
- c Click **OK**, and then click **Print**.

For Macintosh users

- a Customize the settings as needed in the Page Setup dialog:
 - 1 With a document open, choose **File > Page Setup**.
 - 2 Choose a paper size or create a custom size to match the loaded paper.
 - 3 Click **OK**.
- b Customize the settings as needed in the Print dialog:
 - 1 With a document open, choose **File > Print**.
If necessary, click the disclosure triangle to see more options.
 - 2 From the Print dialog and pop-up menus, adjust the settings as needed.
Note: To print on a specific paper type, adjust the paper type setting to match the loaded paper, or select the appropriate tray or feeder.
 - 3 Click **Print**.

Printing specialty documents

Printing on letterhead

- 1 Load letterhead into a tray or drawer.
- 2 From the printer control panel, set the Paper Type to Letterhead. See "Setting the paper size and type" on page 55 for more information.
- 3 Do one of the following:

For Windows users

- a With a document open, click **File → Print**.
- b Click **Properties, Preferences, Options, or Setup**.
- c From the Form Source list box, select the source containing the letterhead.
- d From the Form Type list box, select **Letterhead**.
- e From the Form Size list box, select the letterhead size.
- f Click **OK**, and then click **Print**.

For Macintosh users

- a Customize the settings as needed in the Page Setup dialog.
 - 1 With a document open, choose **File → Page Setup**.
 - 2 From the “Format for” pop-up menu, choose the printer that you want to use.
 - 3 From the Paper Size pop-up menu, choose a paper size that matches the size of the letterhead paper, then create a custom size.
- b Customize the settings as needed in the Print dialog.
 - 1 With a document open, click **File → Print**.
 - 2 From the Printer pop-up menu, choose the printer that you want to use.
 - 3 From the third pop-up menu from the top, choose **Quality & Media**.
 - 4 From the Paper type pop-up menu, choose a paper type.
 - 5 From the Print Quality menu, choose a print quality other than Quick Print.

Tips on using letterhead

Page orientation is important when printing on letterhead. Use the following table to determine which direction to load the letterhead:

Source or process	Print side	Paper orientation
<ul style="list-style-type: none">• Standard 550-sheet tray• Optional 550-sheet tray• Optional 2,000-sheet tray• Optional 550-sheet specialty media drawer	Preprinted letterhead design is placed faceup.	The top edge of the sheet with the logo is placed at the front of the tray.
Duplex (two-sided) printing from trays	Preprinted letterhead design is placed facedown.	The top edge of the sheet with the logo is placed at the back of the tray.
Multipurpose tray (simplex printing)	Preprinted letterhead design is placed facedown.	The top edge of the sheet with the logo should enter the multipurpose tray first.
Multipurpose tray (duplex printing)	Preprinted letterhead design is placed faceup.	The top edge of the sheet with the logo should enter the multipurpose tray last.
Note: Check with the manufacturer or vendor to determine whether the chosen preprinted letterhead is acceptable for laser printers.		

Tips on using transparencies

Print samples on the transparencies being considered for use before buying large quantities.

When printing on transparencies:

- Feed transparencies from any tray or drawer, except the Optional 2,000-sheet tray.
- Use transparencies designed specifically for laser printers. Check with the manufacturer or vendor to ensure transparencies are able to withstand temperatures up to 170°C (338°F) without melting, discoloring, offsetting, or releasing hazardous emissions.
- To prevent print quality problems, avoid getting fingerprints on the transparencies.
- Before loading transparencies, fan the stack to prevent sheets from sticking together.
- We recommend Lexmark part number 12A8240 for letter-size transparencies and Lexmark part number 12A8241 for A4-size transparencies.

Tips on using envelopes

Print samples on the envelopes being considered for use before buying large quantities.

When printing on envelopes:

- Use envelopes designed specifically for laser printers. Check with the manufacturer or vendor to ensure the envelopes can withstand temperatures up to 190°C (374°F) without sealing, wrinkling, curling excessively, or releasing hazardous emissions.
- For the best performance, use envelopes made from 90 g/m² (24 lb bond) paper. Use up to 105 g/m² (28 lb bond) weight for envelopes as long as the cotton content is 25% or less. All-cotton envelopes must not exceed 90 g/m² (24 lb bond) weight.
- Use only new envelopes.
- To optimize performance and minimize jams, do not use envelopes that:
 - Have excessive curl or twist
 - Are stuck together or damaged in any way
 - Have windows, holes, perforations, cutouts, or embossing
 - Have metal clasps, string ties, or folding bars
 - Have an interlocking design
 - Have postage stamps attached
 - Have any exposed adhesive when the flap is in the sealed or closed position
 - Have bent corners
 - Have rough, cockle, or laid finishes
- Adjust the width guides to fit the width of the envelopes.

Note: A combination of high humidity (over 60%) and the high printing temperature may wrinkle or seal envelopes.

Tips on using labels

Print samples on the labels being considered for use before buying large quantities.

Note: Paper labels are supported. Other media such as vinyl may show print quality defects in some environments, and prolonged vinyl label usage may reduce fuser life.

For detailed information on label printing, characteristics, and design, see the *Card Stock & Label Guide* available on the Lexmark Web site at www.lexmark.com/publications.

When printing on labels:

- Use labels designed specifically for laser printers. Check with the manufacturer or vendor to verify that:
 - The labels can withstand temperatures up to 190°C (374°F) without sealing, excessive curling, wrinkling, or releasing hazardous emissions.
 - Label adhesives, face sheet (printable stock), and topcoats can withstand up to 25 psi (172 kPa) pressure without delaminating, oozing around the edges, or releasing hazardous fumes.
- Do not use labels with slick backing material.
- Use full label sheets. Partial sheets may cause labels to peel off during printing, resulting in a jam. Partial sheets also contaminate the printer and the cartridge with adhesive, and could void the printer and cartridge warranties.
- Do not use labels with exposed adhesive.
- Do not print within 1 mm (0.04 in.) of the edge of the label, of the perforations, or between die-cuts of the label.
- Be sure adhesive backing does not reach to the sheet edge. Zone coating of the adhesive at least 1 mm (0.04 in.) away from edges is recommended. Adhesive material contaminates the printer and could void the warranty.
- If zone coating of the adhesive is not possible, remove a 1.6 mm (0.06 in.) strip on the leading and driver edge, and use a non-oozing adhesive.
- Portrait orientation works best, especially when printing bar codes.

Tips on using card stock

Card stock is heavy, single-ply specialty media. Many of its variable characteristics, such as moisture content, thickness, and texture, can significantly impact print quality. Print samples on the card stock being considered for use before buying large quantities.

When printing on card stock:

- Make sure the Paper Type is Card Stock.
- Select the appropriate Paper Texture setting.
- Be aware that preprinting, perforation, and creasing may significantly affect the print quality and cause jams or other paper-handling problems.
- Check with the manufacturer or vendor to ensure the card stock can withstand temperatures up to 190°C (374°F) without releasing hazardous emissions.
- Do not use preprinted card stock manufactured with chemicals that may contaminate the printer. Preprinting introduces semi-liquid and volatile components into the printer.
- Use grain short card stock when possible.

Printing confidential and other held jobs

Holding jobs in the printer

When sending a job to the printer, you can specify in the Print Properties that you want the printer to hold the job in memory until you start the job from the printer control panel. All print jobs that can be initiated by the user at the printer are called *held jobs*.

Note: Confidential, Verify, Reserve, and Repeat print jobs may be deleted if the printer requires extra memory to process additional held jobs.

Job type	Description
Confidential	When you send a Confidential print job to the printer, you must create a PIN in Print Properties. The PIN must be four digits using the numbers 0–9. The job is held in printer memory until you enter the PIN from the printer control panel and choose to print or delete the job.
Verify	When you send a Verify print job, the printer prints one copy and holds the remaining copies in printer memory. Verify lets you examine the first copy to see if it is satisfactory before printing the remaining copies. Once all copies are printed, the job is automatically deleted from printer memory.
Reserve	When you send a Reserve print job, the printer does not print the job immediately. It stores the job in memory so you can print the job later. The job is held in memory until you delete it from the Held Jobs menu.
Repeat	When you send a Repeat print job, the printer prints all requested copies of the job <i>and</i> stores the job in memory so you can print additional copies later. You can print additional copies as long as the job remains stored in memory.

Printing confidential and other held jobs

Confidential and Verify print jobs are automatically deleted from memory after they print. Repeat and Reserve jobs continue to be held in the printer until you choose to delete them.

For Windows Users

- 1 With a document open, click **File → Print**.
- 2 Click **Properties, Preferences, Options, or Setup**.
- 3 Click **Other Options**, and then click **Print and Hold**.
- 4 Select your job type (Confidential, Reserve, Repeat, or Verify), and then assign a user name. For a confidential job, also enter a four-digit PIN.
- 5 Click **OK** or **Print**, and then go to the printer to release the job.
- 6 From the printer control panel, press the down arrow button until **Held jobs** appears, and then press .
- 7 Press the down arrow button until appears next to your user name, and then press .
- 8 Press the down arrow button until appears next to the job type or job name, and then press .
If you selected a job name, proceed to step 11 on page 73.
- 9 After selecting your job type, use the keypad to enter your PIN.
If you enter an invalid PIN, the Invalid PIN screen appears.
 - To re-enter the PIN, make sure **Try again** appears, and then press .
 - To cancel the PIN, press the down arrow button until **Cancel** appears, and then press .
- 10 Press the down arrow button until appears next to the job you want to print, and then press .
- 11 Press the down arrow button until appears next to the number of copies you want to print, and then press .

Note: Use the keypad to enter a number if necessary.

For Macintosh users

- 1** With a document open, choose **File > Print**.
If necessary, click the disclosure triangle to see more options.
- 2** From the print options, Copies & Pages, or General pop-up menu, choose **Job Routing**.
- 3** Select your job type (Confidential, Reserve, Repeat, or Verify), and then assign a user name. For a confidential job, also enter a four-digit PIN.
- 4** Click **Print**, and then go to the printer to release the job.
- 5** From the printer control panel, press the down arrow button until **✓ Held jobs** appears, and then press .
- 6** Press the down arrow button until **✓** appears next to your user name, and then press .
- 7** Press the down arrow button until **✓** appears next to the job type or job name, and then press .
If you selected a job name, proceed to step 10 on page 74.
- 8** After selecting your job type, use the keypad to enter your PIN.
If you enter an invalid PIN, the Invalid PIN screen appears.
 - To re-enter the PIN, make sure **✓ Try again** appears, and then press .
 - To cancel the PIN, press the down arrow button until **✓ Cancel** appears, and then press .
- 9** Press the down arrow button until **✓** appears next to the job you want to print, and then press .
- 10** Press the down arrow button until **✓** appears next to the number of copies you want to print, and then press .

Note: Use the keypad to enter a number if necessary.

Printing from a flash drive

A flash drive port is located on the printer control panel. Insert a flash drive to print supported file types. Supported file types include: .pdf, .gif, .jpeg, .jpg, .bmp, .png, .tiff, .tif, .pcx, .xps, and .dcx.

Many flash drives are tested and approved for use with the printer. For more information, visit the Lexmark Web site at www.lexmark.com.

Notes:

- High-speed flash drives must support the full-speed USB standard. Flash drives supporting only USB low-speed capabilities are not supported.
- Flash drives must support the FAT (*File Allocation Tables*) system. Flash drives formatted with NTFS (*New Technology File System*) or any other file system are not supported.
- Before printing an encrypted .pdf file, enter the file password from the printer control panel.
- You cannot print files for which you do not have printing permissions.

To print from a flash drive:

- 1 Make sure the printer is on and **Ready** appears.
- 2 Insert a flash drive into the flash drive port.



Notes:

- If you insert the flash drive when the printer requires attention, such as when a jam has occurred, then the printer ignores it.
 - If you insert the flash drive while the printer is printing other jobs, then **Printer Busy** appears. After the other jobs are processed, you may need to view the held jobs list to print documents from the flash drive.
- 3 Press the down arrow button until ✓ appears next to the document you want to print, and then press ✓.
- Note:** Folders found on the flash drive appear as folders. File names are appended by the extension type (for example, .jpg).
- 4 Press ✓ to print one copy, or enter the number of copies using the keypad, and then press ✓ to initiate the print job.

If you leave the flash drive in the printer after leaving the initial USB menu screen, you can still print .pdf's from the flash drive as held jobs.

Printing photos from a PictBridge-enabled digital camera

You can connect a PictBridge-enabled digital camera to the printer, and use the buttons on the camera to select and print photos.

- 1 Insert one end of the USB cable into the camera.

Note: Use only the USB cable that came with your camera.

- 2 Insert the other end of the USB cable into the USB port on the front of the printer.

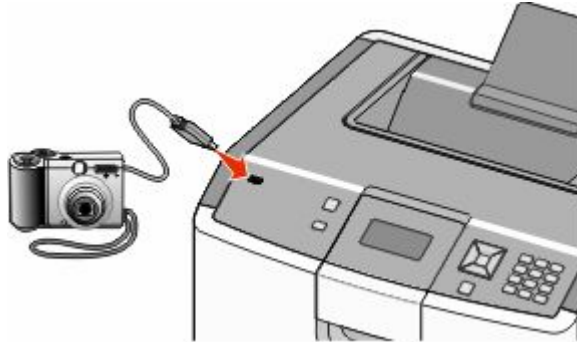

Notes:

- Make sure the PictBridge-enabled digital camera is set to the correct USB mode. See the camera documentation for more information.
- If the PictBridge connection is successful, then a confirmation message appears on the printer display.

- 3 Follow the instructions on the camera to select and print photos.

Note: If the printer is turned off while the camera is connected, then you must disconnect and then reconnect the camera.

Printing information pages

Printing a font sample list



To print samples of the fonts currently available for your printer:

- 1 Make sure the printer is on and **Ready** appears.
- 2 From the printer control panel, press .
- 3 Press the down arrow button until **Reports** appears, and then press .
- 4 Press the down arrow button until **Print Fonts** appears, and then press .
- 5 Press the down arrow button until appears next to **PCL Fonts** or **PostScript Fonts**, and then press .

After the font sample list prints, **Ready** appears.



Printing a directory list

A directory list shows the resources stored in flash memory or on the hard disk.

- 1 Make sure the printer is on and **Ready** appears.
 - 2 From the printer control panel, press .
 - 3 Press the down arrow button until **√Reports** appears, and then press .
 - 4 Press the down arrow button until **√Print Directory** appears, and then press .
- After the directory list prints, **Ready** appears.

Printing the print quality test pages

Print the print quality test pages to isolate print quality problems.

- 1 Turn the printer off.
 - 2 Hold down  and the right arrow button while turning the printer on.
 - 3 Release the buttons when the clock appears, and wait for **CONFIG MENU** to appear.
 - 4 Press the down arrow button until **√Prt Quality Pgs** appears, and then press .
- The print quality test pages print.
- 5 Press the down arrow button until **√Exit Config Menu** appears, and then press .
- Resetting the Printer** appears briefly, followed by a clock, and then **Ready** appears.



Canceling a print job

There are several methods for canceling a print job. The following sections explain how to cancel a print job from the printer control panel, or from a computer depending on the operating system.

Canceling a print job from the printer control panel

If the job is formatting or already printing, and **Cancel a job** appears on the first line of the display:

- 1 Press the arrow buttons until **√Cancel** appears.
A list of jobs appears.
 - 2 Press the arrow buttons until **√** appears next to the job you want to cancel, and then press .
- Canceling <file name>** appears.

Note: Once a print job is sent, to easily cancel a job, press . The Stopped screen appears. Press the arrow buttons until **√Cancel a job** appears, and then press .

Canceling a print job from the computer

To cancel a print job, do one of the following:

For Windows users

- 1 Click , or click **Start** and then click **Run**.
- 2 In the Start Search or Run box, type **control printers**.
- 3 Press **Enter**, or click **OK**.
The printer folder opens.
- 4 Double-click the printer icon.
- 5 Select the job to cancel.
- 6 From the keyboard, press **Delete**.

From the Windows taskbar:

When you send a job to print, a small printer icon appears in the right corner of the taskbar.

- 1 Double-click the printer icon.
A list of print jobs appears in the printer window.
- 2 Select a job to cancel.
- 3 From the keyboard, press **Delete**.

For Macintosh users

In Mac OS X version 10.5 or later:

- 1 From the Apple menu, choose **System Preferences**.
- 2 Click **Print & Fax**, and then double-click the printer icon.
- 3 From the printer window, select the job to cancel.
- 4 From the icon bar at the top of the window, click the **Delete** icon.





In Mac OS X version 10.4 and earlier:

- 1 From the Go menu, choose **Applications**.
- 2 Double-click **Utilities**, and then double-click **Print Center** or **Printer Setup Utility**.
- 3 Double-click the printer icon.
- 4 From the printer window, select the job to cancel.
- 5 From the icon bar at the top of the window, click the **Delete** icon.

Printing in black and white

To print all text and graphics using only the black toner cartridge, set the printer to Black Only.

Note: The printer driver is capable of overriding this setting.

- 1 From the printer control panel, press .
- 2 Press the down arrow button until  **Settings** appears, and then press .
- 3 Press the down arrow button until  **Quality Menu** appears, and then press .

- 4 Press the down arrow button until **Print Mode** appears, and then press .
- 5 Press the down arrow button until **Black Only** appears, and then press . **Submitting selection** appears.

Using Max Speed and Max Yield

The Max Speed and Max Yield settings let you choose between a faster print speed or a higher toner yield. Max Yield is the factory default setting.

- **Max Speed**—Prints in color mode unless black only is selected by the driver. Prints in black only mode if the black only driver setting is selected.
- **Max Yield**—Switches from black to color mode based on the color content found on each page. Frequent color mode switching can result in slower printing if the content of pages is mixed.

To specify the setting:

- 1 Open a Web browser.
- 2 In the address bar, type the network printer or print server IP address, and then press **Enter**.
- 3 Click **Configuration**.
- 4 Click **Print Settings**.
- 5 Click **Setup Menu**.
- 6 From the Printer Usage list, select **Max Speed** or **Max Yield**.
- 7 Click **Submit**.

Clearing jams

By carefully selecting papers and specialty media and loading it properly, you should be able to avoid most jams. For more information, see “Avoiding jams” on page 80. If jams do occur, follow the steps outlined in this chapter.

To resolve the jam messages, you must clear the entire paper path, and press to clear the message and resume printing. The printer prints a new copy of the page that jammed if Jam Recovery is set to On or Auto; however, the Auto setting does not guarantee the page will print.

Note: Jam recovery is set to Auto by default. The printer reprints jammed pages unless the memory required to hold the pages is needed for other printer tasks.

Avoiding jams

The following hints can help you avoid jams:

- Use only recommended paper or specialty media.
For more information, see the *Card Stock & Label Guide* available on the Lexmark Web site at www.lexmark.com/publications.
- Do not load too much paper. Make sure the stack height does not exceed the indicated maximum height.
- Do not load wrinkled, creased, damp, or curled paper.
- Flex, fan, and straighten paper before loading it.
- Do not use paper that has been cut or trimmed by hand.
- Do not mix paper sizes, weights, or types in the same stack.
- Store the paper in an appropriate environment.
- Do not remove trays while the printer is printing. Wait for **Load tray <x>** or **Ready** to appear before removing a tray.
- Do not load the multipurpose tray while the printer is printing. Load the tray prior to printing, or wait for **Load Multipurpose tray with <x>** to appear.
- Push all trays in firmly after loading paper.
- Make sure the guides in the trays are properly positioned.
- Make sure all paper sizes and paper types are set correctly in the printer control panel menu.
- Make sure all printer cables are attached correctly. For more information, see the setup documentation.

Understanding jam messages

The following table lists the jam messages that can occur.

Message	See
200.yy Paper jam, check [area name]. Leave paper in bin.	“200 paper jams” on page 81
200.yy Paper jam, [x] pages jammed. Leave paper in bin.	“200 or 201 paper jam” on page 82 “201 paper jam” on page 83

Message	See
201.yy Paper jam, check [area name]. Leave paper in bin.	"200 paper jams" on page 81
201.yy Paper jam, [x] pages jammed. Leave paper in bin.	"200 or 201 paper jam" on page 82 "201 paper jam" on page 83
202.yy Paper jam, check [area name]. Leave paper in bin.	"202 paper jam" on page 84
202.yy Paper jam, [x] pages jammed. Leave paper in bin.	
203.yy Paper jam, check [area name]. Leave paper in bin.	"203 paper jam" on page 86
203.yy Paper jam, [x] pages jammed. Leave paper in bin.	
230.yy Paper jam, [area name]. Leave paper in bin.	"230 paper jam" on page 87
230.yy Paper jam, [x] pages jammed. Leave paper in bin.	
241.yy Paper jam, check [area name]. Leave paper in bin.	"240 paper jam" on page 88
241.yy Paper jam, [x] pages jammed. Leave paper in bin.	
24n.yy Paper jam, check [area name]. Leave paper in bin.	"240 paper jam" on page 88
24n.yy Paper jam, [x] pages jammed. Leave paper in bin.	
250.yy Paper jam, check [area name]. Leave paper in bin.	"250 paper jam" on page 90
250.yy Paper jam, [x] pages jammed. Leave paper in bin.	

200 paper jams

If paper jams behind the inner door, but not under the photoconductor units, **200 .xx Paper jam** appears.

Note: To avoid overexposing the photoconductor units, do not leave the front door open longer than 10 minutes.

1 Open the front door.



CAUTION—HOT SURFACE: The fuser and the inside of the printer near the fuser may be hot. Wait for the fuser to cool before clearing jams from this area.

2 Pull the jammed paper up and out to remove it from behind the toner cartridge area.

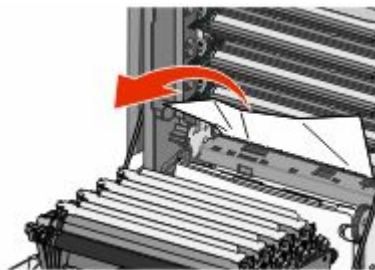

Note: Make sure all paper fragments are removed.

3 Close the front door.

4 Press .

200 or 201 paper jam

If paper jams under the photoconductor units, 200.xx Paper jam or 201.xx Paper jam may appear.

1 Open the front door.

Note: To avoid overexposing the photoconductor units, do not leave the front door open longer than 10 minutes.

2 Pull the paper forward if it is lodged under the photoconductor units.

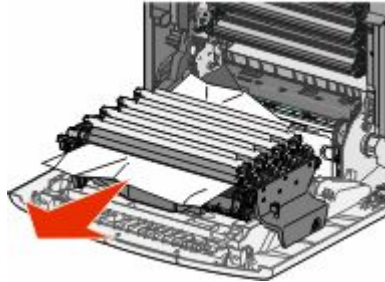

Note: You may need to remove the photoconductor units if the paper is lodged too tightly under them.

3 Remove each photoconductor unit, and place it on a flat surface.

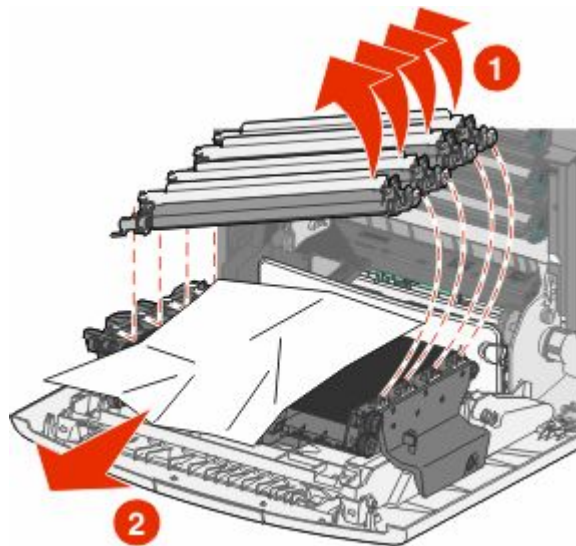

4 Remove the jammed paper, and then replace each photoconductor unit.

5 Close the front door.

6 Press from the printer control panel.

201 paper jam

If paper is jammed under the fuser or the top cover, **201.xx Paper jam** appears.

 **CAUTION—HOT SURFACE:** The fuser and the inside of the printer near the fuser may be hot. Wait for the fuser to cool before clearing jams from this area.

- 1 Open the front door, and then open the top cover.

Warning—Potential Damage: To avoid overexposing the photoconductors, do not leave the front door open longer than 10 minutes.

- 2 Determine where the jam is located:

- a If paper is visible under the fuser, grasp it on each side and pull it forward.

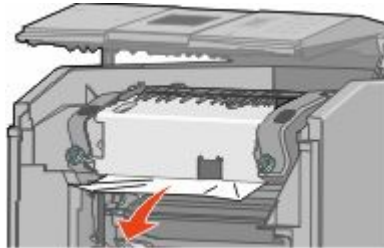

- b If paper is not visible, then you will need to remove the fuser unit.

Warning—Potential Damage: Do not touch the center of the fuser unit. Doing so may cause your fingers to touch the roller underneath the fuser unit. Touching the fuser roller will damage the fuser.

- 1 Turn the screws on the fuser unit to the left to loosen them.

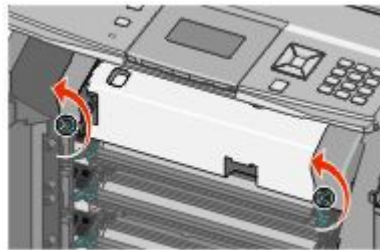

- 2 Lift the handholds on each side of the fuser unit, and then pull forward to remove it.



- 3 Remove the jammed paper.

4 Align the fuser unit using the handholds on each side, and place it back into the printer.



5 Turn the screws to the right to securely fasten the fuser unit.

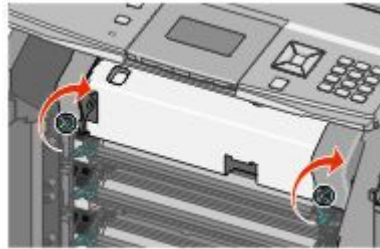

c Close the top cover, and then close the front door.

d Press .

202 paper jam

If paper is jammed both under the fuser unit and in the slot behind the fuser unit, then **202 .xx Paper jam** appears.

If the paper is visible in the standard exit bin, then grasp the paper and pull it away from the bin.



Paper jam under the fuser unit

Warning—Potential Damage: To avoid overexposing the photoconductors, do not leave the front door open longer than 10 minutes.

- 1 Open the front door, and then open the top cover.

 **CAUTION—HOT SURFACE:** The fuser and the inside of the printer near the fuser may be hot. Wait for the fuser to cool before clearing jams from this area.

- 2 Grasp the paper on each side and pull it forward.

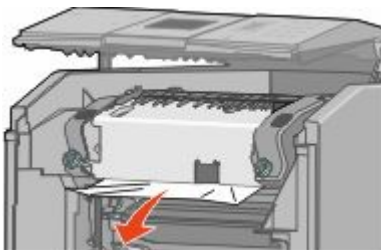

- 3 Close the top cover, and then close the front door.

- 4 Press .

Paper jam behind the fuser unit

Warning—Potential Damage: To avoid overexposing the photoconductors, do not leave the front door open longer than 10 minutes.

- 1 Open the front door, and then open the top cover.

 **CAUTION—HOT SURFACE:** The fuser and the inside of the printer near the fuser may be hot. Wait for the fuser to cool before clearing jams from this area.

- 2 If the paper is jammed behind the fuser, then you will need to remove the fuser unit.

Warning—Potential Damage: Do not touch the center of the fuser unit. Doing so may cause your fingers to touch the roller underneath the fuser unit. Touching the fuser roller will damage the fuser.

- a Turn the screws on the fuser unit to the left to loosen them.

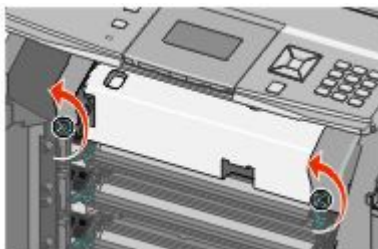

- b Lift the handholds on each side of the fuser unit, and then pull forward to remove it.





- c Place the fuser unit on a flat surface.

- 3 Pull the paper gently out of the printer or up toward the standard exit bin to remove it.
- 4 Reinstall the fuser unit.
 - a Align the fuser unit using the handholds on each side, and place it back into the printer.

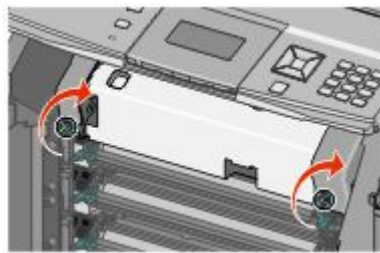

- b Turn the screws to the right to fasten the fuser unit securely.



- 5 Close the top cover, and then close the front door.
- 6 Press .

203 paper jam

If paper is jammed under the rollers near the fuser, or in the standard exit bin 203 .xx Paper jam appears.

- 1 Grasp paper that is visible in the standard exit bin and pull it away from the bin.



- 2 Open the front door, and then open the top cover.

- 3 Grasp the paper on each side, and pull it out gently.

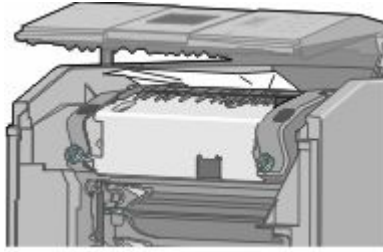

- 4 Close the top cover, and then close the front door.

- 5 Press .

230 paper jam

If paper is jammed between the front door and Tray 1, **230 .xx Paper jam** appears.

- 1 Remove Tray 1.
- 2 Open the front door.
- 3 Pull straight up to remove the jammed paper.

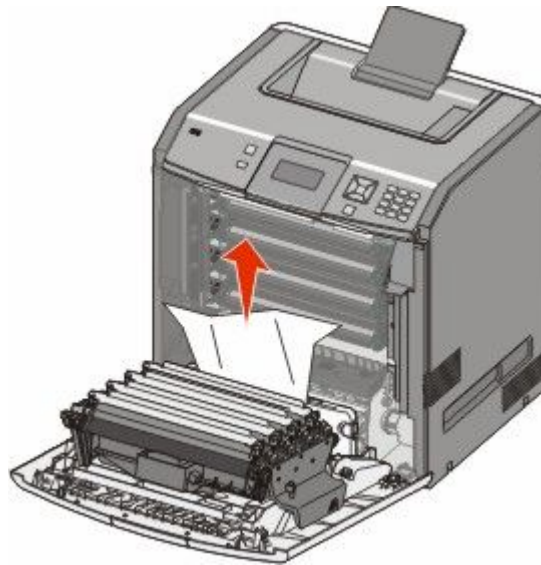

- 4 Pull out on the release tabs to allow the front door to split.

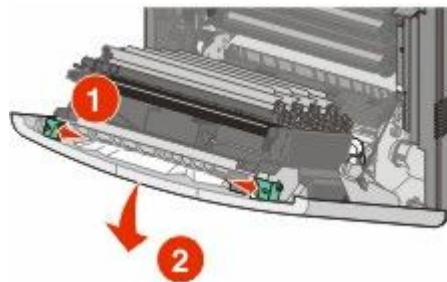

- 5 Pull straight out to remove any jammed paper.

Clearing jams

- 6 Close the front door.
- 7 Reinsert Tray 1.
- 8 Press .

240 paper jam

If paper is jammed in Tray 1, **241 . xx Paper jam** appears. If paper is jammed in any of the optional trays, **24n . xx Paper jam** appears.

Paper jammed in Tray 1

- 1 Open Tray 1, and then pull the jammed pages straight up and out.

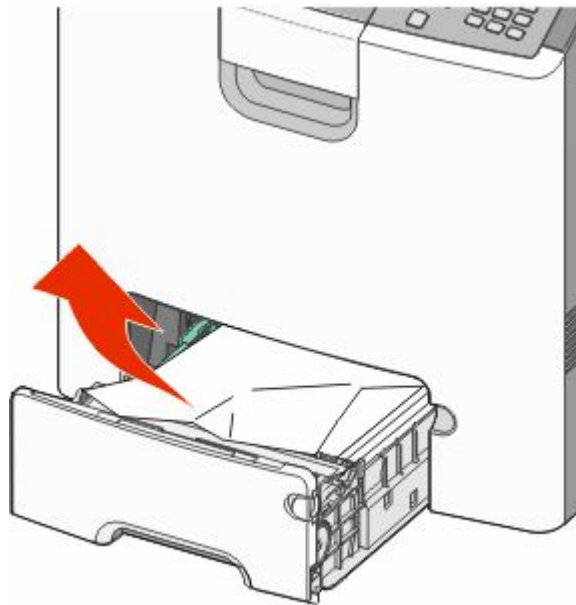

- 2 Close Tray 1.
- 3 Press .

Paper jammed in front of Tray 1

- 1 Open Tray 1, and then pull the jammed pages up and out.

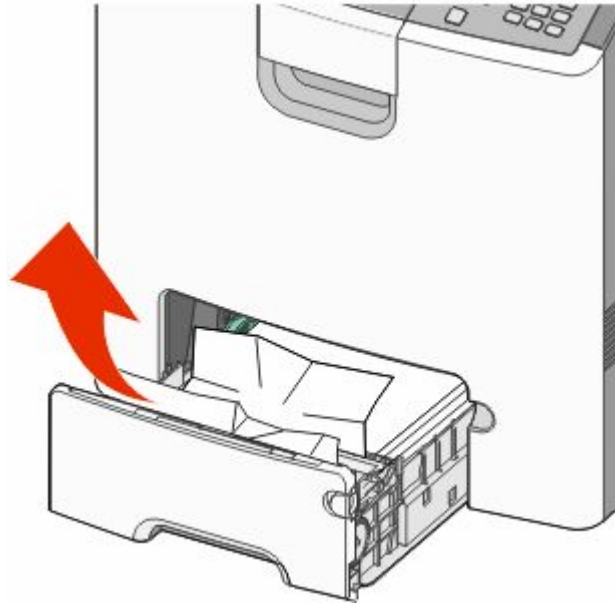

- 2 Close Tray 1.

- 3 Press .

Paper jammed in one of the optional trays

If the jammed pages are located in one of the optional trays, follow the appropriate steps below to remove the pages.

- 1 Open the specified optional tray, and pull the jammed pages out as illustrated.

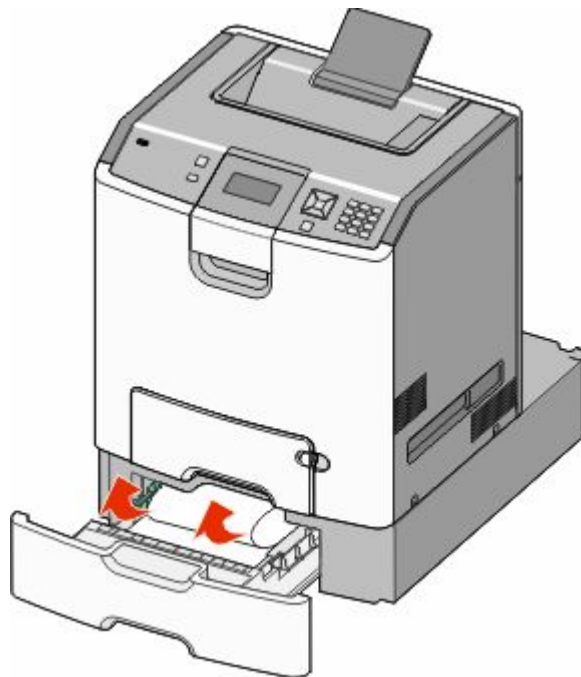

2 Close the specified optional tray.

3 Press .

250 paper jam

If paper is jammed in the multipurpose tray, 250 .xx Paper jam appears.

1 Press the paper release lever, and then remove the jammed pages from the multipurpose tray.

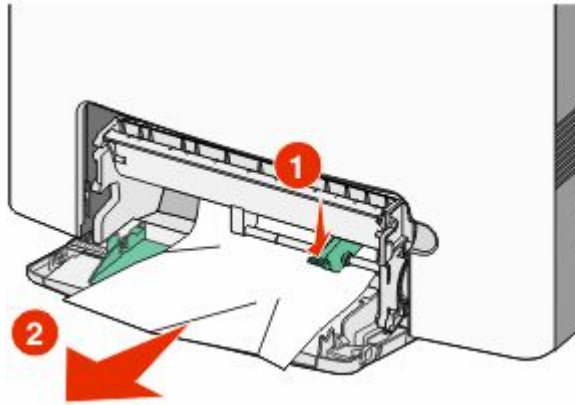

2 Load new paper into the multipurpose tray.

3 Press .

Understanding printer menus

Menus list

A number of menus are available to make it easy for you to change printer settings. This diagram shows the items available under each menu.

Supplies

- Replace Supply
- Cyan Cartridge
- Magenta Cartridge
- Yellow Cartridge
- Black Cartridge
- Cyan Photoconductor
- Magenta Photoconductor
- Yellow Photoconductor
- Black Photoconductor
- Waste Toner Box
- Fuser
- Transfer Module

Paper Menu

- Default Source
- Paper Size/Type
- Configure MP
- Substitute Size
- Paper Texture
- Paper Weight
- Paper Loading
- Custom Types
- Universal Setup

Reports

- Menu Settings Page
- Device Statistics
- Network Setup Page
- Network <x> Setup Page
- Wireless Setup Page¹
- Profiles List
- Netware Setup Page
- Print Fonts
- Print Directory
- Asset Report

Settings

- General Settings
- Setup Menu
- Finishing Menu
- Quality Menu
- Utilities Menu
- XPS Menu
- PDF Menu
- PostScript Menu
- PCL Emul Menu
- HTML Menu
- Image Menu
- PictBridge Menu
- Flash Drive Menu

Security

- Miscellaneous Security Setting
- Confidential Print
- Disk Wiping
- Security Audit Log
- Set Date/Time

Network/Ports

- Active NIC
- Standard Network²
- Standard USB
- Parallel <x>
- Serial <x>
- SMTP Setup

Help

- Print All
- Color Quality
- Print Quality
- Printing Guide
- Media Guide
- Print Defects
- Menu Map
- Information Guide
- Connection Guide
- Moving Guide
- Supplies Guide

¹Only appears on wireless models.

²Depending on the printer setup, this menu item appears as Standard Network, Wireless Network, or Network <x>.

Supplies menu

Menu item	Description
<p>Replace Supply</p> <ul style="list-style-type: none"> All Cyan Photoconductor Magenta Photoconductor Yellow Photoconductor Black Photoconductor 	<p>Provides the option to reset the supply counter for the photoconductor just replaced, or for all photoconductors</p> <p>Select the photoconductor, and then select Yes or No:</p> <ul style="list-style-type: none"> • Select Yes to reset the supply counter. • Select No to exit. <p>Note: A supply counter must be reset manually after a photoconductor is replaced.</p>
<p>Cyan, Magenta, Yellow, or Black Cartridge</p> <ul style="list-style-type: none"> Low Invalid Replace Missing or Defective OK Uncalibrated Unsupported 	<p>Shows the status of the toner cartridges</p>
<p>Cyan, Magenta, Yellow, or Black Photoconductor</p> <ul style="list-style-type: none"> Life Warning Replace Missing OK 	<p>Shows the status of the cyan, yellow, and magenta photoconductors</p>
<p>Black Photoconductor</p> <ul style="list-style-type: none"> Life Warning Replace Missing OK 	<p>Shows the status of the black photoconductor</p>
<p>Waste Toner Box</p> <ul style="list-style-type: none"> Near Full Replace Missing OK 	<p>Shows the status of the waste toner box</p>
<p>Fuser</p> <ul style="list-style-type: none"> Life Warning Replace Missing OK 	<p>Shows the status of the fuser</p>
<p>Transfer module</p> <ul style="list-style-type: none"> Life Warning Replace Missing OK 	<p>Shows the status of the transfer module</p>

Paper menu

Default Source menu

Menu item	Description
Default Source Tray <x> Multipurpose tray	Sets a default paper source for all print jobs Notes: <ul style="list-style-type: none">• From the Paper menu, Configure Multipurpose tray must be set to Cassette for Multipurpose tray to appear as a menu setting.• Tray 1 (standard tray) is the factory default setting.• If the same size and type of paper are in two trays and the Paper Size and Paper Type settings match, then the trays are automatically linked. When one tray is empty, the job prints using the linked tray.

Paper Size/Type menu

Menu item	Description
Tray <x> Size A4 A5 A6 JIS B5 Legal Letter Executive Oficio (México) Folio Statement Universal	Specifies the paper size loaded in each tray Notes: <ul style="list-style-type: none">• Letter is the US factory default setting. A4 is the international factory default setting.• For trays with automatic size sensing, only the size detected by the hardware appears.• If the same size and type of paper are in two trays and the Paper Size and Paper Type settings match, then the trays are automatically linked. When one tray is empty, the job prints using the linked tray.

Note: Only installed trays are listed in this menu.

Menu item	Description
<p>Tray <x> Type</p> <ul style="list-style-type: none"> Plain Paper Card Stock Transparency Glossy Heavy Glossy Labels Bond Letterhead Preprinted Colored Paper Light Paper Heavy Paper Rough Paper Recycled Custom Type <x> 	<p>Specifies the type of paper loaded in each tray</p> <p>Notes:</p> <ul style="list-style-type: none"> • Plain Paper is the factory default setting for Tray 1. Custom Type <x> is the factory default setting for all other trays. • If available, a user-defined name will appear instead of Custom Type <x>. • Use this menu item to configure automatic tray linking.
<p>Multipurpose Tray Size</p> <ul style="list-style-type: none"> A4 A5 A6 Executive Oficio (México) Folio JIS B5 Legal Letter Statement Universal 7 3/4 Envelope 9 Envelope 10 Envelope DL Envelope C5 Envelope B5 Envelope Other Envelope 	<p>Specifies the paper size loaded in the multipurpose tray</p> <p>Notes:</p> <ul style="list-style-type: none"> • From the Paper menu, Configure Multipurpose Tray must be set to Cassette for Multipurpose Tray to appear as a menu setting. • Letter is the US factory default setting. A4 is the international factory default setting.
<p>Note: Only installed trays are listed in this menu.</p>	

Menu item	Description
<p>Multipurpose Tray Type</p> <ul style="list-style-type: none"> Plain Paper Card Stock Transparency Glossy Heavy Glossy Labels Bond Envelope Rough Envelope Letterhead Preprinted Colored Paper Light Paper Heavy Paper Rough Paper Recycled Custom Type <x> 	<p>Specifies the type of paper loaded in the multipurpose tray</p> <p>Notes:</p> <ul style="list-style-type: none"> • From the Paper menu, Configure Multipurpose Tray must be set to Cassette for Multipurpose Tray to appear as a menu setting. • Plain paper is the factory default setting.
<p>Manual Paper Size</p> <ul style="list-style-type: none"> A4 A5 JIS B5 Letter Legal Executive Folio Statement Universal 	<p>Specifies the size of the paper being manually loaded</p> <p>Note: Letter is the US factory default setting. A4 is the international factory default setting.</p>
<p>Manual Paper Type</p> <ul style="list-style-type: none"> Paper Card Stock Transparencies Glossy paper Heavy Glossy Labels Light Paper Heavy Paper Rough Paper 	<p>Specifies the type of paper being manually loaded</p> <p>Note: Plain paper is the factory default setting.</p>
<p>Note: Only installed trays are listed in this menu.</p>	

Menu item	Description
Manual Envelope Size 7 3/4 Envelope 9 Envelope 10 Envelope C5 Envelope B5 Envelope DL Envelope Other Envelope	Specifies the size of the envelope being manually loaded Note: 10 Envelope is the US factory default setting. DL Envelope is the international factory default setting.
Manual Envelope Type Envelope Rough Envelope Custom Type <x>	Specifies the type of envelope being manually loaded Note: Envelope is the factory default setting.
Note: Only installed trays are listed in this menu.	

Configure MP menu

Menu item	Description
Configure MP Cassette Manual	Determines when the printer selects paper from the multipurpose feeder Notes: <ul style="list-style-type: none"> • Cassette is the factory default setting. • The Cassette setting configures the multipurpose feeder as an automatic paper source. • When Manual is selected, the multipurpose feeder can be used only for manual feed print jobs.

Substitute Size menu

Menu item	Description
Substitute Size Off Statement/A5 Letter/A4 All Listed	Substitutes a specified paper size if the requested paper size is not available Notes: <ul style="list-style-type: none"> • All Listed is the factory default setting. All available substitutions are allowed. • The Off setting indicates no size substitutions are allowed. • Setting a substitution lets the job print without a Change Paper message appearing.

Paper Texture menu

Menu item	Description
Plain Texture Smooth Normal Rough	Specifies the relative texture of the paper loaded in a specific tray Note: Normal is the factory default setting.
Card Stock Texture Smooth Normal Rough	Specifies the relative texture of the card stock loaded in a specific tray Notes: <ul style="list-style-type: none"> • Normal is the factory default setting. • Settings appear only if card stock is supported.
Transparency Texture Smooth Normal Rough	Specifies the relative texture of the transparencies loaded in a specific tray Note: Normal is the factory default setting.
Recycled Texture Smooth Normal Rough	Specifies the relative texture of the recycled paper loaded in a specific tray
Glossy Texture Smooth Normal Rough	Specifies the relative texture of the Glossy paper loaded in a specific tray Note: Normal is the factory default setting.
Labels Texture Smooth Normal Rough	Specifies the relative texture of the labels loaded in a specific tray Note: Normal is the factory default setting.
Bond Texture Smooth Normal Rough	Specifies the relative texture of the paper loaded in a specific tray Note: Rough is the factory default setting.
Envelope Texture Smooth Normal Rough	Specifies the relative texture of the envelopes loaded in a specific tray Note: Normal is the factory default setting.
Rough Envelope Texture Smooth Normal Rough	Specifies the relative texture of the envelopes loaded in a specific tray Note: Rough is the factory default setting.
Letterhead Texture Smooth Normal Rough	Specifies the relative texture of the paper loaded in a specific tray Note: Normal is the factory default setting.

Menu item	Description
Preprinted Texture Smooth Normal Rough	Specifies the relative texture of the paper loaded in a specific tray Note: Normal is the factory default setting.
Colored Texture Smooth Normal Rough	Specifies the relative texture of the paper loaded in a specific tray Note: Normal is the factory default setting.
Light Texture Smooth Normal Rough	Specifies the relative texture of the paper loaded in a specific tray Note: Normal is the factory default setting.
Heavy Texture Smooth Normal Rough	Specifies the relative texture of the paper loaded in a specific tray Note: Normal is the factory default setting.
Rough Texture Smooth Normal Rough	Specifies the relative texture of the paper loaded in a specific tray Note: Rough is the factory default setting.
Custom <x> Texture Smooth Normal Rough	Specifies the relative texture of the custom paper loaded in a specific tray Notes: <ul style="list-style-type: none"> • Normal is the factory default setting. • Settings appear only if the custom type is supported.

Paper Weight menu

Menu item	Description
Plain Weight Light Normal Heavy	Specifies the relative weight of the paper loaded in a specific tray Note: Normal is the factory default setting.
Card Stock Weight Light Normal Heavy	Specifies the relative weight of the card stock loaded in a specific tray Notes: <ul style="list-style-type: none"> • Normal is the factory default setting. • Settings appear only if card stock is supported.
Transparency Weight Light Normal Heavy	Specifies the relative weight of the transparencies loaded in a specific tray Note: Normal is the factory default setting.

Menu item	Description
Recycled Weight Light Normal Heavy	Specifies the relative weight of the recycled paper loaded in a specific tray Note: Normal is the factory default setting.
Glossy Weight Light Normal Heavy	Specifies the relative weight of the Glossy paper loaded in a specific tray Note: Normal is the factory default setting.
Labels Weight Light Normal Heavy	Specifies the relative weight of the labels loaded in a specific tray Note: Normal is the factory default setting.
Bond Weight Light Normal Heavy	Specifies the relative weight of the paper loaded in a specific tray Note: Rough is the factory default setting.
Envelope Weight Light Normal Heavy	Specifies the relative weight of the envelopes loaded in a specific tray Note: Normal is the factory default setting.
Letterhead Weight Light Normal Heavy	Specifies the relative weight of the paper loaded in a specific tray Note: Normal is the factory default setting.
Preprinted Weight Light Normal Heavy	Specifies the relative weight of the paper loaded in a specific tray Note: Normal is the factory default setting.
Colored Weight Light Normal Heavy	Specifies the relative weight of the paper loaded in a specific tray Note: Normal is the factory default setting.
Custom <x> Weight Light Normal Heavy	Specifies the relative weight of the custom paper loaded in a specific tray Notes: <ul style="list-style-type: none"> • Normal is the factory default setting. • Settings appear only if the custom type is supported.

Paper Loading menu

Menu item	Description
Recycled Loading Duplex Off	Determines whether 2-sided printing occurs for all jobs that specify Recycled as the paper type Note: Off is the factory default setting.
Glossy Loading Duplex Off	Determines whether 2-sided printing occurs for all jobs that specify Glossy as the paper type Note: Off is the factory default setting.
Letterhead Loading Duplex Off	Determines whether 2-sided printing occurs for all jobs that specify Letterhead as the paper type Note: Off is the factory default setting.
Preprinted Loading Duplex Off	Determines whether 2-sided printing occurs for all jobs that specify Preprinted as the paper type Note: Off is the factory default setting.
Colored Loading Duplex Off	Determines whether 2-sided printing occurs for all jobs that specify Colored as the paper type Note: Off is the factory default setting.
Custom <x> Loading Duplex Off	Determines whether 2-sided printing occurs for all jobs that specify Custom <x> as the paper type Notes: <ul style="list-style-type: none"> • Off is the factory default setting. • Custom <x> Loading is available only if the custom type is supported.
Notes: <ul style="list-style-type: none"> • Duplex sets the printer default to 2-sided printing for every print job unless 1-sided printing is selected from Print Properties. • If Duplex is selected, then all print jobs are sent through the duplex unit including 1-sided jobs. 	

Custom Types menu

Menu item	Description
Custom Type <x> Paper Card Stock Glossy Heavy Glossy Light Paper Heavy Paper Rough Paper Recycled Transparency Labels Envelope Rough Envelope	Associates a paper or specialty media type with a factory default Custom Type <x> name or a user-defined Custom Name created from the Embedded Web Server or MarkVision™ Professional Notes: <ul style="list-style-type: none"> • Paper is the factory default setting. • The custom media type must be supported by the selected tray or multipurpose tray in order to print from that source.
Recycled Paper Card Stock Transparency Labels Envelope	Specifies a paper type when the Recycled setting is selected in other menus Notes: <ul style="list-style-type: none"> • Paper is the factory default setting. • The custom media type must be supported by the selected tray or multipurpose tray in order to print from that source.

Universal Setup menu

These menu items are used to specify the height and width of the Universal Paper Size. The Universal Paper Size is a user-defined paper size setting. It is listed with the other paper size settings and includes similar options, such as support for duplex printing and printing multiple pages on one sheet.

Menu item	Description
Units of Measure Inches Millimeters	Identifies the units of measure Notes: <ul style="list-style-type: none"> • Inches is the US factory default setting. • Millimeters is the international factory default setting.
Portrait Width 3–8.5 inches 76–216 mm	Sets the portrait width Notes: <ul style="list-style-type: none"> • If the width exceeds the maximum, then the printer uses the maximum width allowed. • 8.5 inches is the US factory default setting. Inches can be increased in 0.01-inch increments. • 216 mm is the international factory default setting. Millimeters can be increased in 1-mm increments.

Menu item	Description
Portrait Height 3–14.17 inches 76–360 mm	Sets the portrait height Notes: <ul style="list-style-type: none"> • If the height exceeds the maximum, then the printer uses the maximum height allowed. • 14 inches is the US factory default setting. Inches can be increased in 0.01-inch increments. • 356 mm is the international factory default setting. Millimeters can be increased in 1-mm increments.
Feed Direction Short Edge Long Edge	Specifies the feed direction Notes: <ul style="list-style-type: none"> • Short Edge is the factory default setting. • Long Edge appears only if the longest edge is shorter than the maximum width supported in the tray.

Reports menu

Reports menu

Menu item	Description
Menu Settings Page	Prints a report containing information about paper loaded into trays, installed memory, the total page count, alarms, timeouts, the printer control panel language, the TCP/IP address, the status of supplies, the status of the network connection, and other information Note: The page prints when this item is selected.
Device Statistics	Prints a report containing printer statistics such as supply information and details about printed pages Note: The page prints when this item is selected.
Network Setup Page	Prints a report containing information about the network printer settings, such as the TCP/IP address information Notes: <ul style="list-style-type: none"> • This menu item appears only for network printers or printers connected to print servers. • The page prints when this item is selected.
Network <x> Setup Page	Prints a report containing information about the network printer settings, such as the TCP/IP address information Notes: <ul style="list-style-type: none"> • This selection is available when more than one network option is installed. • This menu item appears only for network printers or printers connected to print servers. • The page prints when this item is selected.

Menu item	Description
Wireless Setup Page	Prints a report containing information about the wireless network settings, such as TCP/IP address information Notes: <ul style="list-style-type: none"> • This menu item appears only for printers with an optional wireless print server installed. • The page prints when this item is selected.
Profiles List	Prints a list of profiles stored in the printer Note: The page prints when this item is selected.
NetWare Setup Page	Prints a report containing NetWare-specific information about the network settings Notes: <ul style="list-style-type: none"> • This menu item appears only for printers with an internal print server installed. • The page prints when this item is selected.
Print Fonts PCL Fonts PostScript Fonts	Prints a report of all the fonts available for the printer language currently set in the printer Note: A separate list is available for PCL and PostScript emulations.
Print Directory	Prints a list of all the resources stored on an optional flash memory card or printer hard disk Notes: <ul style="list-style-type: none"> • Job Buffer Size must be set to 100%. • The optional flash memory or printer hard disk must be installed correctly and working properly. • The page prints when this item is selected.
Asset Report	Prints a report containing each piece of printer asset information, such as the serial number and model name. Note: The page prints when this item is selected.

Network/Ports menu

Active NIC menu

Menu item	Description
Active NIC Auto <list of available network cards>	Notes: <ul style="list-style-type: none"> • Auto is the factory default setting. • This menu item appears only if an optional network card is installed.

Standard Network or Network <x> menus

Note: Only active ports appear in this menu; all inactive ports are omitted.

Menu item	Description
PCL SmartSwitch On Off	Sets the printer to automatically switch to PCL emulation when a print job requires it, regardless of the default printer language Notes: <ul style="list-style-type: none"> • On is the factory default setting. • When the Off setting is used, the printer does not examine incoming data. • When the Off setting is used, the printer uses PostScript emulation if PS SmartSwitch is set to On. It uses the default printer language specified in the Setup menu if PS SmartSwitch is set to Off.
PS SmartSwitch On Off	Sets the printer to automatically switch to PS emulation when a print job requires it, regardless of the default printer language Notes: <ul style="list-style-type: none"> • On is the factory default setting. • When the Off setting is used, the printer does not examine incoming data. • When the Off setting is used, the printer uses PCL emulation if PCL SmartSwitch is set to On. It uses the default printer language specified in the Setup menu if PCL SmartSwitch is set to Off.
NPA Mode Off Auto	Sets the printer to perform the special processing required for bidirectional communication following the conventions defined by the NPA protocol Notes: <ul style="list-style-type: none"> • Auto is the factory default setting. • Changing this setting from the printer control panel and then exiting the menus causes the printer to restart. The menu selection is updated.
Network Buffer Auto 3K to <maximum size allowed>	Sets the size of the network input buffer Notes: <ul style="list-style-type: none"> • Auto is the factory default setting. • The value can be changed in 1-K increments. • The maximum size allowed depends on the amount of memory in the printer, the size of the other link buffers, and whether Resource Save is set to On or Off. • To increase the maximum size range for the Network Buffer, disable or reduce the size of the parallel, serial, and USB buffers. • Changing this setting from the printer control panel and then exiting the menus causes the printer to restart. The menu selection is updated.

Menu item	Description
Job Buffering Off On Auto	Temporarily stores jobs on the printer hard disk before printing. This menu only appears if a formatted disk is installed. Notes: <ul style="list-style-type: none"> • Off is the factory default setting. • The On value buffers jobs on the printer hard disk. This menu selection appears only when a formatted disk is installed and is not defective. • The Auto setting buffers print jobs only if the printer is busy processing data from another input port. • Changing this setting from the printer control panel and then exiting the menus causes the printer to restart. The menu selection is updated.
Mac Binary PS On Off Auto	Sets the printer to process Macintosh binary PostScript print jobs Notes: <ul style="list-style-type: none"> • Auto is the factory default setting. • The Off setting filters print jobs using the standard protocol. • The On setting processes raw binary PostScript print jobs.
Std Network Setup Reports or Network Reports Network Card TCP/IP IPv6 AppleTalk NetWare LexLink Net <x> Setup Reports or Network Reports Network Card TCP/IP IPv6 Wireless AppleTalk NetWare LexLink	For descriptions and settings of the network setup menus, see the following: <ul style="list-style-type: none"> • “Network Reports menu” on page 105 • “Network Card menu” on page 106 • “TCP/IP menu” on page 106 • “IPv6 menu” on page 107 • “Wireless menu” on page 108 • “AppleTalk menu” on page 108 • “NetWare menu” on page 109 • “LexLink menu” on page 110 Note: The Wireless menu appears only when the printer is connected to a wireless network.

Network Reports menu

This menu is available from the Network/Ports menu:

Network/Ports → Standard Network or Network <x> → Std Network Setup or Net <x> Setup → Reports or Network Reports

Menu item	Description
Print Setup Page Print NetWare Setup Page	Prints a report containing information about the current network setup Notes: <ul style="list-style-type: none"> • The Setup Page contains information about the network printer settings, such as the TCP/IP address. • The NetWare Setup Page menu item appears only on models that support NetWare and shows information about NetWare settings.

Network Card menu

This menu is available from the Network/Ports menu:

Network/Ports → Standard Network or Network <x> → Std Network Setup or Net <x> Setup → Network Card

Menu item	Description
View Card Status Connected Disconnected	Lets you view the connection status of the Network Card
View Card Speed	Lets you view the speed of a currently active network card
Network Address UAA LAA	Lets you view the network addresses
Job Timeout 0-225 seconds	Sets the amount of time in seconds that a network print job can take before it is canceled Notes: <ul style="list-style-type: none"> • 90 seconds is the factory default setting. • A setting value of 0 disables the timeout. • If a value of 1–9 is selected, then the setting is saved as 10.
Banner Page Off On	Allows the printer to print a banner page. Note: Off is the factory default setting.

TCP/IP menu

Use the following menu items to view or set the TCP/IP information.

Note: This menu is available only for network models or printers attached to print servers.

This menu is available from the Network/Ports menu:

Network/Ports → Standard Network or Network <x> → Std Network Setup or Net <x> Setup → TCP/IP

Menu item	Description
Activate On Off	Activates TCP/IP Note: On is the factory default setting.
View Hostname	Lets you view the current TCP/IP hostname Note: This can be changed only from the Embedded Web Server.
IP Address	Lets you view or change the current TCP/IP Address Note: Manually setting the IP address sets the Enable DHCP and Enable Auto IP settings to Off. It also sets Enable BOOTP and Enable RARP to Off on systems that support BOOTP and RARP.
Netmask	Lets you view or change the current TCP/IP Netmask
Gateway	Lets you view or change the current TCP/IP Gateway
Enable DHCP On Off	Specifies the DHCP address and parameter assignment setting
Enable RARP On Off	Specifies the RARP address assignment setting Note: On is the factory default setting.
Enable BOOTP On Off	Specifies the BOOTP address assignment setting Note: On is the factory default setting.
AutoIP Yes No	Specifies the Zero Configuration Networking setting Note: Yes is the factory default setting.
Enable FTP/TFTP Yes No	Enables the built-in FTP server, which allows you to send files to the printer using the File Transfer Protocol. Note: Yes is the factory default setting.
Enable HTTP Server Yes No	Enables the built-in web server (Embedded Web Server). When enabled, the printer can be monitored and managed remotely using a web browser. Note: Yes is the factory default setting.
WINS Server Address	Lets you view or change the current WINS Server Address
DNS Server Address	Lets you view or change the current DNS Server Address

IPv6 menu

Use the following menu items to view or set the Internet Protocol version 6 (IPv6) information.

Note: This menu is available only for network models or printers attached to print servers.

This menu is available from the Network/Ports menu:

Network/Ports → Standard Network or Network <x> → Std Network Setup or Net <x> Setup → IPv6

Menu item	Description
Enable IPv6 On Off	Enables IPv6 in the printer Note: On is the factory default setting.
Auto Configuration On Off	Specifies whether the network adapter accepts the automatic IPv6 address configuration entries provided by a router Note: On is the factory default setting.
View Hostname View Address View Router Address	Lets you view the current setting Note: These settings can be changed only from the Embedded Web Server.
Enable DHCPv6 On Off	Enables DHCPv6 in the printer Note: On is the factory default setting.

Wireless menu

Use the following menu items to view or configure the wireless internal print server settings.

Note: This menu is available only for models connected to a wireless network.

This menu is available from the Network/Ports menu:

Network/Ports → Network <x> → Net <x> Setup → Wireless

Menu item	Description
Network Mode Infrastructure Ad hoc	Specifies the network mode Notes: <ul style="list-style-type: none"> • Infrastructure mode lets the printer access a network using an access point. • Ad hoc is the factory default setting. Ad hoc mode configures the printer for wireless networking directly between it and a computer.
Compatibility 802.11n 802.11b/g 802.11b/g/n	Specifies the wireless standard for the wireless network
Choose Network <list of available networks>	Lets you select an available network for the printer to use
View Signal Quality	Lets you view the quality of the wireless connection
View Security Mode	Lets you view the encryption method for the wireless connection. "Disabled" indicates that the wireless network is not encrypted.

AppleTalk menu

This menu is available from the Network/Ports menu:

Network/Ports → Standard Network or Network <x> → Std Network Setup or Net <x> Setup → AppleTalk

Menu item	Description
Activate On Off	Activates AppleTalk support Note: On is the factory default setting.
View Name	Shows the assigned AppleTalk name Note: The name can be changed only from the Embedded Web Server.
View Address	Shows the assigned AppleTalk address Note: The address can be changed only from the Embedded Web Server.
Set Zone <list of zones available on the network>	Provides a list of AppleTalk zones available on the network Note: The default setting is the default zone for the network. If no default zone exists, the zone marked with an * is the default setting.

NetWare menu

This menu is available from the Network/Ports menu:

Network/Ports → Standard Network or Network <x> → Std Network Setup or Net <x> Setup → NetWare

Menu item	Description
Activate Yes No	Activates NetWare support Note: No is the factory default setting.
View Login Name	Lets you view the assigned NetWare login name Note: This can be changed only from the Embedded Web Server.
Print Mode	Lets you view the assigned NetWare print mode Note: This can be changed only from the Embedded Web Server.
Network Number	Lets you view the assigned NetWare network number Note: This can be changed only from the Embedded Web Server.
Select SAP Frames Ethernet 802.2 Ethernet 802.3 Ethernet Type II Ethernet SNAP	Enables the Ethernet frame type setting Note: On is the factory default setting for all menu items.
Packet Burst Yes No	Reduces network traffic by allowing the transfer and acknowledgement of multiple data packets to and from the NetWare server Note: Yes is the factory default setting.
NSQ/GSQ Mode Yes No	Specifies the NSQ/GSQ Mode setting Note: Yes is the factory default setting.

LexLink menu

This menu is available from the Network/Ports menu:

Network/Ports → Standard Network or Network <x> → Std Network Setup or Net <x> Setup → LexLink menu

Menu item	Description
Activate On Off	Activates LexLink support Note: Off is the factory default setting.
View Nickname	Lets you view the assigned LexLink nickname Note: The LexLink nickname can be changed only from the Embedded Web Server.

Standard USB and USB <x> menus

Menu item	Description
PCL SmartSwitch On Off	Sets the printer to automatically switch to PCL emulation when a print job received through a USB port requires it, regardless of the default printer language Notes: <ul style="list-style-type: none"> • On is the factory default setting. • When the Off setting is used, the printer does not examine incoming data. • When the Off setting is used, the printer uses PostScript emulation if the PS Smartswitch setting is On. It uses the default printer language specified in the Setup menu if the PS SmartSwitch setting is Off.
PS SmartSwitch On Off	Sets the printer to automatically switch to PS emulation when a print job received through a USB port requires it, regardless of the default printer language Notes: <ul style="list-style-type: none"> • On is the factory default setting. • When the Off setting is used, the printer does not examine incoming data. • When the Off setting is used, the printer uses PCL emulation if the PCL Smartswitch setting is On. It uses the default printer language specified in the Setup menu if the PCL SmartSwitch setting is Off.
NPA Mode On Off Auto	Sets the printer to perform the special processing required for bidirectional communication following the conventions defined by the NPA protocol Notes: <ul style="list-style-type: none"> • Auto is the factory default setting. • Changing this setting from the control panel and then exiting the menus causes the printer to restart. The menu selection is updated.

Menu item	Description
USB Buffer Disabled Auto 3k to <maximum size allowed>	Sets the size of the USB input buffer Notes: <ul style="list-style-type: none"> • Auto is the factory default setting. • The Disabled setting turns off job buffering. Any jobs already buffered on the disk are printed before normal processing is resumed. • The USB buffer size value can be changed in 1k increments. • The maximum size allowed depends on the amount of memory in the printer, the size of the other link buffers, and whether the Resource Save setting is On or Off. • To increase the maximum size range for the USB Buffer, disable or reduce the size of the parallel, serial, and network buffers. • Changing this setting from the control panel and then exiting the menus causes the printer to restart. The menu selection is updated.
Job Buffering On Off Auto	Temporarily stores jobs on the printer hard disk before printing Notes: <ul style="list-style-type: none"> • Off is the factory default setting. • The On setting buffers jobs on the printer hard disk. • The Auto setting buffers print jobs only if the printer is busy processing data from another input port. • Changing this setting from the control panel and then exiting the menus causes the printer to restart. The menu selection is updated.
Mac Binary PS On Off Auto	Sets the printer to process Macintosh binary PostScript print jobs Notes: <ul style="list-style-type: none"> • Auto is the factory default setting. • The Off setting filters print jobs using the standard protocol. • The On setting processes raw binary PostScript print jobs.
ENA Address	Sets the network address information for an external print server that is attached to the printer using a USB cable Note: This menu item is available only if the printer is attached to an external print server through the USB port.
ENA Netmask	Sets the netmask information for an external print server that is attached to the printer using a USB cable Note: This menu item is available only if the printer is attached to an external print server through the USB port.
ENA Gateway	Sets the gateway information for an external print server that is attached to the printer using a USB cable Note: This menu item is available only if the printer is attached to an external print server through the USB port.

Parallel <x> menu

Menu item	Description
PCL SmartSwitch On Off	Sets the printer to automatically switch to PCL emulation when a print job received through a serial port requires it, regardless of the default printer language Notes: <ul style="list-style-type: none"> • On is the factory default setting. • When the Off setting is used, the printer does not examine incoming data. • When the Off setting is used, the printer uses PostScript emulation if PS SmartSwitch is set to On. It uses the default printer language specified in the Setup menu if PS SmartSwitch is set to Off.
PS SmartSwitch On Off	Sets the printer to automatically switch to PS emulation when a print job received through a serial port requires it, regardless of the default printer language Notes: <ul style="list-style-type: none"> • On is the factory default setting. • When the Off setting is used, the printer does not examine incoming data. • When the Off setting is used, the printer uses PCL emulation if PCL SmartSwitch is set to On. It uses the default printer language specified in the Setup menu if PCL SmartSwitch is set to Off.
NPA Mode On Off Auto	Sets the printer to perform the special processing required for bidirectional communication following the conventions defined by the NPA protocol Notes: <ul style="list-style-type: none"> • Auto is the factory default setting. • Changing this setting from the printer control panel and then exiting the menus causes the printer to restart. The menu selection is updated.
Parallel Buffer Disabled Auto 3k to <maximum size allowed>	Sets the size of the parallel input buffer Notes: <ul style="list-style-type: none"> • Auto is the factory default setting. • The Disabled setting turns off job buffering. Any jobs already buffered on the disk are printed before normal processing is resumed. • The parallel buffer size setting can be changed in 1k increments. • The maximum size allowed depends on the amount of memory in the printer, the size of the other link buffers, and whether Resource Save is set to On or Off. • To increase the maximum size range for the Parallel Buffer, disable or reduce the size of the USB, serial, and network buffers. • Changing this setting from the printer control panel and then exiting the menus causes the printer to restart. The menu selection is updated.

Menu item	Description
Job Buffering Off On Auto	Temporarily stores jobs on the printer hard disk before printing Notes: <ul style="list-style-type: none"> • Off is the factory default setting. • The Off setting does not buffer print jobs to the printer hard disk. • The On setting buffers jobs on the printer hard disk. • The Auto setting buffers print jobs only if the printer is busy processing data from another input port. • Changing this setting from the printer control panel and then exiting the menus causes the printer to restart. The menu selection is updated.
Advanced Status On Off	Enables bidirectional communication through the parallel port Notes: <ul style="list-style-type: none"> • On is the factory default setting. • The Off setting disables parallel port negotiation.
Parallel Protocol Standard Fastbytes	Specifies the parallel port protocol Notes: <ul style="list-style-type: none"> • Fastbytes is the factory default setting. It provides compatibility with most existing parallel ports and is the recommended setting. • The Standard setting tries to resolve parallel port communication problems.
Honor Init On Off	Determines whether or not the printer honors printer hardware initialization requests from the computer Notes: <ul style="list-style-type: none"> • Off is the factory default setting. • The computer requests initialization by activating the Init signal from the parallel port. Many personal computers activate the Init signal each time the computer is turned on.
Parallel Mode 2 On Off	Determines whether or not the parallel port data is sampled on the leading or trailing edge of strobe Note: On is the factory default setting.
Mac Binary PS On Off Auto	Sets the printer to process Macintosh binary PostScript print jobs Notes: <ul style="list-style-type: none"> • Auto is the factory default setting. • The Off setting filters print jobs using the standard protocol. • The On setting processes raw binary PostScript print jobs.
ENA Address <xxx>.<xxx>.<xxx>.<xxx>	Sets the network address information for an external print server that is attached to the printer using a USB cable Note: This menu item is available only if the printer is attached to an external print server through the USB port.

Menu item	Description
ENA Netmask <xxx>.<xxx>.<xxx>.<xxx>	Sets the netmask information for an external print server that is attached to the printer using a USB cable Note: This menu item is available only if the printer is attached to an external print server through the USB port.
ENA gateway <xxx>.<xxx>.<xxx>.<xxx>	Sets the gateway information for an external print server that is attached to the printer using a USB cable Note: This menu item is available only if the printer is attached to an external print server through the USB port.

Serial <x> menu

Menu item	Description
PCL SmartSwitch On Off	Sets the printer to automatically switch to PCL emulation when a print job received through a serial port requires it, regardless of the default printer language Notes: <ul style="list-style-type: none"> • On is the factory default setting. • When the Off setting is used, the printer does not examine incoming data. • When the Off setting is used, the printer uses PostScript emulation if PS SmartSwitch is set to On. It uses the default printer language specified in the Setup menu if PS SmartSwitch is set to Off.
PS SmartSwitch On Off	Sets the printer to automatically switch to PS emulation when a print job received through a serial port requires it, regardless of the default printer language Notes: <ul style="list-style-type: none"> • On is the factory default setting. • When the Off setting is used, the printer does not examine incoming data. • When the Off setting is used, the printer uses PCL emulation if PCL SmartSwitch is set to On. It uses the default printer language specified in the Setup menu if PCL SmartSwitch is set to Off.
NPA Mode On Off Auto	Sets the printer to perform the special processing required for bidirectional communication following the conventions defined by the NPA protocol Notes: <ul style="list-style-type: none"> • Auto is the factory default setting. • When the On setting is used, the printer performs NPA processing. If the data is not in NPA format, it is rejected as bad data. • When the Off setting is used, the printer does not perform NPA processing. • When the Auto setting is used, the printer examines data, determines the format, and then processes it appropriately. • Changing this setting from the control panel and then exiting the menus causes the printer to restart. The menu selection is updated.

Menu item	Description
<p>Serial Buffer</p> <p>Disabled Auto 3k to <maximum size allowed></p>	<p>Sets the size of the serial input buffer</p> <p>Notes:</p> <ul style="list-style-type: none"> • Auto is the factory default setting. • The Disabled setting turns off job buffering. Any jobs already buffered on the disk are printed before normal processing is resumed. • The serial buffer size setting can be changed in 1k increments. • The maximum size allowed depends on the amount of memory in the printer, the size of the other link buffers, and whether Resource Save is set to On or Off. • To increase the maximum size range for the Serial Buffer, disable or reduce the size of the parallel, serial, and network buffers. • Changing this setting from the control panel and then exiting the menus causes the printer to restart. The menu selection is updated.
<p>Job Buffering</p> <p>Off On Auto</p>	<p>Temporarily stores jobs on the printer hard disk before printing</p> <p>Notes:</p> <ul style="list-style-type: none"> • Off is the factory default setting. • The Off setting does not buffer print jobs to the hard disk. • The On setting buffers jobs on the printer hard disk. • The Auto setting buffers print jobs only if the printer is busy processing data from another input port. • Changing this setting from the control panel and then exiting the menus causes the printer to restart. The menu selection is updated.
<p>Serial Protocol</p> <p>DTR DTR/DSR XON/XOFF XON/XOFF/DTR XONXOFF/DTRDSR</p>	<p>Selects the hardware and software handshaking settings for the serial port</p> <p>Notes:</p> <ul style="list-style-type: none"> • DTR is the factory default setting. • DTR/DSR is a hardware handshaking setting. • XON/XOFF is a software handshaking setting. • XON/XOFF/DTR and XON/XOFF/DTR/DSR are combined hardware and software handshaking settings.
<p>Robust XON</p> <p>On Off</p>	<p>Determines whether or not the printer communicates availability to the computer</p> <p>Notes:</p> <ul style="list-style-type: none"> • Off is the factory default setting. • This menu item applies only to the serial port if Serial Protocol is set to XON/XOFF.

Menu item	Description
Baud 1200 2400 4800 9600 19200 38400 57600 115200 138200 172800 230400 345600	Specifies the rate at which data can be received through the serial port Notes: <ul style="list-style-type: none"> • 9600 is the factory default setting. • 138200, 172800, 230400, and 345600 baud rates are only displayed in the Standard Serial menu. These settings do not appear in the Serial Option 1, Serial Option 2, or Serial Option 3 menus.
Data Bits 7 8	Specifies the number of data bits that are sent in each transmission frame Note: 8 is the factory default setting.
Parity Even Odd None Ignore	Sets the parity for serial input and output data frames Note: None is the factory default setting.
Honor DSR On Off	Determines whether the printer uses the DSR Signal. DSR is a handshaking signal used by most serial cables. Notes: <ul style="list-style-type: none"> • Off is the factory default setting. • The serial port uses DSR to distinguish data sent by the computer from data created by electrical noise in the serial cable. The electrical noise can cause stray characters to print. Select On to prevent stray characters from printing.

SMTP Setup menu

Use the following menu to configure the SMTP server.

Menu item	Description
Primary SMTP Gateway Primary SMTP Gateway Port Secondary SMTP Gateway Secondary SMTP Gateway Port	Specifies SMTP server port information Note: 25 is the default SMTP gateway port. Range is 1-65536.
SMTP Timeout 5–30	Specifies the amount of time in seconds before the server stops trying to send the e-mail Note: 30 seconds is the factory default setting.
Reply Address	Specifies a reply address of up to 128 characters in e-mail sent by the printer

Menu item	Description
Use SSL Disabled Negotiate Required	Sets the printer to use SSL for increased security when connecting to the SMTP server Notes: <ul style="list-style-type: none"> • Disabled is the factory default setting for Use SSL. • When the Negotiate setting is used, your SMTP server determines if SSL will be used.
SMTP Server Authentication No authentication required Login/Plain CRAM-MD5 Digest-MD5 NTLM Kerberos 5	Specifies the type of user authentication required Note: "No authentication required" is the factory default setting.
Device-Initiated E-mail None Use Device SMTP Credentials Device Userid Device Password Kerberos 5 Realm NTLM Domain	Specifies what credentials will be used when communicating to the SMTP server. Some SMTP servers require credentials in order to send e-mail. Notes: <ul style="list-style-type: none"> • None is the factory default setting for Device-Initiated E-mail. • Device Userid and Device Password are used to log in to the SMTP server when "Use Device SMTP Credentials" is selected.

Security menu

Miscellaneous menu

Menu item	Description
Panel Logins Login failures Failure time frame Lockout time Login timeout	Limits the number and time frames of failed login attempts from the printer control panel before <i>all</i> users are locked out Notes: <ul style="list-style-type: none"> • "Login failures" specifies the number of failed login attempts before users are locked out. Settings range from 1–50. 3 attempts is the factory default setting. • "Failure time frame" specifies the time frame during which failed login attempts can be made before users are locked out. Settings range from 1–60 minutes. 5 minutes is the factory default setting. • "Lockout time" specifies how long users are locked out after exceeding the login failures limit. Settings range from 0–60 minutes. 5 minutes is the factory default setting. • "Login timeout" specifies how long the printer remains idle on the Home screen before automatically logging the user off. Settings range from 1–900 minutes. 300 minutes is the factory default setting.

Menu item	Description
Remote Logins Login failures Failure time frame Lockout time Login timeout	Limits the number and time frames of failed login attempts from a computer before <i>all</i> remote users are locked out Notes: <ul style="list-style-type: none"> • “Login failures” specifies the number of failed login attempts before users are locked out. Settings range from 1–50. 3 attempts is the factory default setting. • “Failure time frame” specifies the time frame during which failed login attempts can be made before users are locked out. Settings range from 1–60 minutes. 5 minutes is the factory default setting. • “Lockout time” specifies how long a user is locked out after exceeding the login failures limit. Settings range from 0–60 minutes. 5 minutes is the factory default setting. • “Login timeout” specifies how long the remote interface remains idle before automatically logging the user off. Settings range from 1–900 minutes. 300 minutes is the factory default setting.

Confidential Print menu

Menu item	Description
Max Invalid PIN Off 2–10	Limits the number of times an invalid PIN can be entered Notes: <ul style="list-style-type: none"> • Off is the default setting. • This menu item appears only if a printer hard disk is installed. • Once a limit is reached, the jobs for that user name and that PIN are deleted.
Job Expiration Off 1 hour 4 hours 24 hours 1 week	Limits the amount of time a confidential job stays in the printer before it is deleted Notes: <ul style="list-style-type: none"> • Off is the default setting. • If the Job Expiration setting is changed while confidential jobs reside on the printer RAM or printer hard disk, the expiration time for those print jobs does not change to the new default value. • If the printer is turned off, all confidential jobs held in printer RAM are deleted.

Disk Wiping menu

Menu item	Description
<p>Automatic Wiping</p> <p>Off</p> <p>On</p>	<p>Disk Wiping erases <i>only</i> print job data that <i>is not</i> currently in use by the file system from the printer hard disk. All permanent data on the printer hard disk is preserved, such as downloaded fonts, macros, and held jobs.</p> <p>Automatic Wiping marks all disk space used by a previous job and does not permit the file system to reuse this space until it has been sanitized.</p> <p>Only Automatic Wiping enables users to activate disk wiping without having to take the printer offline for an extended amount of time.</p> <p>Notes:</p> <ul style="list-style-type: none"> • This menu item appears only if a formatted, non-defective printer hard disk is installed. • Off is the default setting. • Due to the large amount of resources required for Automatic Wiping, activating this option may decrease printer performance, especially if the printer requires hard disk space faster than it can be wiped and returned to service.
<p>Manual Wiping</p> <p>Start now</p> <p>Do not start now</p>	<p>Disk Wiping erases <i>only</i> print job data that <i>is not</i> currently in use by the file system from the printer hard disk. All permanent data on the printer hard disk is preserved, such as downloaded fonts, macros, and held jobs.</p> <p>Manual Wiping overwrites all disk space that has been used to hold data from a print job that has been processed (i.e. printed). This type of wipe <i>does not</i> erase any information related to an unprocessed print job.</p> <p>Notes:</p> <ul style="list-style-type: none"> • This menu item appears only if a formatted, non-defective printer hard disk is installed. • "Do not start now" is the default setting. • If the Disk Wiping access control is activated, then a user must successfully authenticate and have the required authorization in order to initiate the disk wipe.
<p>Automatic Method</p> <p>Single pass</p> <p>Multiple pass</p>	<p>Disk Wiping erases <i>only</i> print job data that <i>is not</i> currently in use by the file system from the printer hard disk. All permanent data on the printer hard disk is preserved, such as downloaded fonts, macros, and held jobs.</p> <p>Notes:</p> <ul style="list-style-type: none"> • This menu item appears only if a formatted, non-defective printer hard disk is installed. • Single pass is the default setting. • Highly confidential information should be wiped using the Multiple pass method <i>only</i>.

Menu item	Description
Manual Method Single pass Multiple pass	<p>Disk Wiping erases <i>only</i> print job data that <i>is not</i> currently in use by the file system from the printer hard disk. All permanent data on the printer hard disk is preserved, such as downloaded fonts, macros, and held jobs.</p> <p>Both manual and scheduled wiping allow the file system to reuse marked disk space without first having to wipe it.</p> <p>Notes:</p> <ul style="list-style-type: none"> • This menu item appears only if a formatted, non-defective printer hard disk is installed. • Single pass is the default setting. • Highly confidential information should be wiped using the Multiple Pass method <i>only</i>.
Scheduled Method Single pass Multiple pass	<p>Disk Wiping erases <i>only</i> print job data that <i>is not</i> currently in use by the file system from the printer hard disk. All permanent data on the printer hard disk is preserved, such as downloaded fonts, macros, and held jobs.</p> <p>Both manual and scheduled wiping allow the file system to reuse marked disk space without first having to wipe it.</p> <p>Notes:</p> <ul style="list-style-type: none"> • This menu item appears only if a formatted, non-defective printer hard disk is installed. • Single pass is the default setting. • Highly confidential information should be wiped using the Multiple Pass method <i>only</i>. • Scheduled wipes are initiated <i>without</i> displaying a user warning or confirmation message.

Security Audit Log menu

Menu item	Description
Export Log	<p>Enables an authorized user to export the security log</p> <p>Notes:</p> <ul style="list-style-type: none"> • To export the log from the printer control panel, a flash drive must be attached to the printer. • From the Embedded Web Server, the log can be downloaded to a computer.
Delete Log Delete now Do not delete	<p>Specifies whether audit logs are deleted</p> <p>Note: Delete Now is the factory default setting.</p>
Configure Log Enable Audit Enable Remote Syslog Remote Syslog Facility Severity of events to log	<p>Specifies whether and how the audit logs are created</p> <p>Note: Factory default settings enable the security audit log.</p>

Set Date/Time menu

Menu item	Description
View Date/Time	Lets you view the current date and time settings for the printer
Set Date/Time <input date/time>	Note: Date/Time is set in YYYY-MM-DD HH:MM format.
Time Zone <list of time zones>	Note: GMT is the factory default setting.
Observe DST On Off	Note: On is the factory default setting and uses the applicable Daylight Saving Time associated with the Time Zone setting.
Enable NTP On Off	Enables Network Time Protocol, which synchronizes the clocks of devices on a network Note: On is the factory default setting.

Settings menu

General Settings menu

Menu item	Description
Display Language English Francais Deutsch Italiano Espanol Dansk Norsk Nederlands Svenska Portuguese Suomi Russian Polski Magyar Turkce Cesky Simplified Chinese Traditional Chinese Korean Japanese	Sets the language of the text appearing on the display Note: All languages may not be available for all printers.

Menu item	Description
<p>Eco-Mode</p> <ul style="list-style-type: none"> Off Energy Energy/Paper Paper 	<p>Minimizes the use of energy, paper, or specialty media</p> <p>Notes:</p> <ul style="list-style-type: none"> • Off is the factory default setting. Off resets the printer to its factory default settings. • The Energy setting minimizes the power used by the printer. Performance may be affected, but print quality is not. • Paper minimizes the amount of paper and specialty media needed for a print job. Performance may be affected, but print quality is not. • Energy/Paper minimizes the use of power and of paper and specialty media.
<p>Quiet Mode</p> <ul style="list-style-type: none"> Off (Image/Photo) On (Text/Graphics) 	<p>Reduces the amount of noise produced by the printer</p> <p>Notes:</p> <ul style="list-style-type: none"> • Off is the factory default setting. This setting supports the performance specifications for your printer. • On configures the printer to produce as little noise as possible. This setting is best suited for printing text and line graphics. • For optimal printing of color-rich documents, set Quiet Mode to Off. • Selecting Photo from the driver may disable Quiet Mode and provide better print quality and full speed printing.
<p>Run Initial Setup</p> <ul style="list-style-type: none"> Yes No 	<p>Instructs the printer to run the setup wizard</p> <p>Notes:</p> <ul style="list-style-type: none"> • Yes is the factory default setting. • After completing the setup wizard by selecting Done at the Country select screen, the default becomes No.
<p>Paper Sizes</p> <ul style="list-style-type: none"> US Metric 	<p>Notes:</p> <ul style="list-style-type: none"> • The initial setting is determined by your Country selection in the initial setup wizard. • Changing this setting also changes the Units of Measurement setting in the Universal Setup menu and the default for each input source in the Paper Size/Type menu.

Menu item	Description
<p>Alarms</p> <p>Alarm Control Cartridge Alarm</p>	<p>Sets an alarm to sound when the printer requires operator intervention</p> <p>Available selections for each alarm type are:</p> <ul style="list-style-type: none"> Off Single Continuous <p>Notes:</p> <ul style="list-style-type: none"> • Single is the factory default setting for Alarm Control. Single sounds three quick beeps. • Off is the factory default setting for Cartridge Alarm. Off means no alarm will sound. • Continuous repeats three beeps every 10 seconds.
<p>Timeouts</p> <p>Job Hold Timeout 5–255</p>	<p>Sets the amount of time the printer waits for user intervention before it holds jobs that require unavailable resources and continues to print other jobs in the print queue</p> <p>Notes:</p> <ul style="list-style-type: none"> • 30 seconds is the factory default setting. • This menu item appears only when a hard disk is installed.
<p>Timeouts</p> <p>Power Saver 1–240</p>	<p>Sets the amount of time the printer waits after a job is printed before it goes into a reduced power state</p> <p>Notes:</p> <ul style="list-style-type: none"> • 30 minutes is the factory default setting. • Lower settings conserve more energy, but may require longer warm-up times. • Select the lowest setting if the printer shares an electrical circuit with room lighting or you notice lights flickering in the room. • Select a high setting if the printer is in constant use. Under most circumstances, this keeps the printer ready to print with minimum warm-up time.
<p>Timeouts</p> <p>Screen Timeout 15–300</p>	<p>Sets the amount of time in seconds the printer waits before returning the printer display to a Ready state</p> <p>Note: 30 seconds is the factory default setting.</p>
<p>Timeouts</p> <p>Print Timeout Disabled 1–255</p>	<p>Sets the amount of time in seconds the printer waits to receive an end-of-job message before canceling the remainder of the print job</p> <p>Notes:</p> <ul style="list-style-type: none"> • 90 seconds is the factory default setting. • When the timer expires, any partially printed page still in the printer is printed, and then the printer checks to see if any new print jobs are waiting. • Print Timeout is available only when using PCL emulation. This setting has no effect on PostScript emulation print jobs.

Menu item	Description
Timeouts Wait Timeout Disabled 15–6553515	Sets the amount of time in seconds the printer waits for additional data before canceling a print job Notes: <ul style="list-style-type: none"> • 40 seconds is the factory default setting. • Wait Timeout is available only when the printer is using PostScript emulation. This setting has no effect on PCL emulation print jobs.
Print Recovery Auto Continue Disabled 5–255	Lets the printer automatically continue printing from certain offline situations when not resolved within the specified time period Note: Disabled is the factory default setting.
Print Recovery Jam Recovery Auto	Specifies whether the printer reprints jammed pages Notes: <ul style="list-style-type: none"> • Auto is the factory default setting. The printer reprints jammed pages unless the memory required to hold the pages is needed for other printer tasks. • On sets the printer to always reprint jammed pages. • Off sets the printer to never reprint jammed pages.
Print Recovery Page Protect Off On	Lets the printer successfully print a page that may not have printed otherwise Notes: <ul style="list-style-type: none"> • Off is the factory default setting. Off prints a partial page when there is not enough memory to print the whole page. • On sets the printer to process the whole page so that the entire page prints.
Factory Defaults Do Not Restore Restore Now	Returns the printer settings to the factory default settings Notes: <ul style="list-style-type: none"> • Do Not Restore is the factory default setting. Do Not Restore keeps the user-defined settings. • Restore Now returns all printer settings to the factory default settings except Network/Ports menu settings. All downloads stored in RAM are deleted. Downloads stored in flash memory or on a printer hard disk are not affected.
Custom Home Message None IP Address Hostname Contact Name Location Date/Time Zero Configuration Name Custom Text 1	Displays information pertaining to the selected Custom Home Messages on the printer control panel display

Setup menu

Menu item	Description
<p>Printer Language</p> <ul style="list-style-type: none"> PCL Emulation PS Emulation 	<p>Sets the default printer language</p> <p>Notes:</p> <ul style="list-style-type: none"> • PCL emulation uses a PCL interpreter for processing print jobs. PostScript emulation uses a PS interpreter for processing print jobs. • PCL is the factory default printer language. • Setting a printer language as the default does not prevent a software program from sending print jobs that use another printer language.
<p>Job Waiting</p> <ul style="list-style-type: none"> On Off 	<p>Specifies that print jobs be removed from the print queue if they require unavailable printer options or custom settings. They are stored in a separate print queue, so other jobs print normally. When the missing information and/or options are obtained, the stored jobs print.</p> <p>Notes:</p> <ul style="list-style-type: none"> • Off is the factory default setting. • This menu appears only if a non-Read Only printer hard disk is installed. This requirement ensures that stored jobs are not deleted if the printer loses power.
<p>Print Area</p> <ul style="list-style-type: none"> Normal Whole Page 	<p>Sets the logical and physical printable area</p> <p>Notes:</p> <ul style="list-style-type: none"> • Normal is the factory default setting. When attempting to print data in the non-printable area defined by the Normal setting, the printer clips the image at the boundary. • The Whole Page setting allows the image to be moved into the non-printable area defined by the Normal setting, but the printer will clip the image at the Normal setting boundary. • The Whole Page setting only affects pages printed using a PCL 5e interpreter. This setting has no effect on pages printed using the PCL XL or PostScript interpreter.
<p>Printer Usage</p> <ul style="list-style-type: none"> Max Yield Max Speed 	<p>Sets the printer for a faster print speed or a higher toner yield.</p> <p>Note: Max Yield is the factory default.</p>
<p>Black Only Mode</p> <ul style="list-style-type: none"> Off On 	<p>Sets the printer to print text and graphics using only the black toner cartridge.</p> <p>Note: Off is the factory default.</p> <p>Note: The printer driver is capable of overriding this setting.</p>

Menu item	Description
<p>Download Target</p> <p>RAM Flash Disk</p>	<p>Sets the storage location for downloads</p> <p>Notes:</p> <ul style="list-style-type: none"> • RAM is the factory default setting. • Storing downloads in flash memory or on a printer hard disk places them in permanent storage. Downloads remain in flash memory or on the printer hard disk even when the printer is turned off. • Storing downloads in RAM is temporary. • This menu appears only if a flash and/or disk option is installed.
<p>Job Accounting</p> <p>On Off</p>	<p>Specifies whether the printer stores statistical information about the most recent print jobs on the hard disk</p> <p>Notes:</p> <ul style="list-style-type: none"> • Off is the factory default setting. Off means the printer does not store job statistics. • The statistics include a record of print errors, the print time, the job size in bytes, the requested paper size and type, the total number of printed pages, and the total number of copies requested. • Job Accounting is available only when a printer hard disk is installed and working properly. It should not be Read/Write or Write protected. Job Buffer Size should not be set to 100%. • Changing this setting from the printer control panel and then exiting the menus causes the printer to reset. The menu selection is updated.
<p>Resource Save</p> <p>On Off</p>	<p>Specifies how the printer handles temporary downloads, such as fonts and macros stored in RAM, when the printer receives a job that requires more memory than is available</p> <p>Notes:</p> <ul style="list-style-type: none"> • Off is the factory default setting. Off sets the printer to retain the downloads only until memory is needed. Downloads are deleted in order to process print jobs. • The On setting retains the downloads during language changes and printer resets. If the printer runs out of memory, 38 Memory Full appears, and downloads are not deleted.
<p>Print All Order</p> <p>Alphabetically Newest First Oldest First</p>	<p>Specifies the order in which held and confidential jobs are printed when Print All is selected</p> <p>Notes:</p> <ul style="list-style-type: none"> • Alphabetically is the factory default setting. • Print jobs always appear in alphabetical order on the printer control panel.

Finishing menu

Menu item	Description
Sides (Duplex) 2 sided 1 sided	Specifies whether duplex (2-sided) printing is set as the default for all print jobs Notes: <ul style="list-style-type: none"> • 1 sided is the factory default setting. • To set 2-sided printing from the software program: for Windows users, click File → Print, and then click Properties, Preferences, Options, or Setup; for Macintosh users, choose File > Print, and then adjust the settings from the print dialog and pop-up menus.
Duplex Binding Long Edge Short Edge	Defines the way duplexed pages are bound and how the printing on the back of the page is oriented in relation to the printing on the front of the page Notes: <ul style="list-style-type: none"> • Long Edge is the factory default setting. • Long Edge specifies that binding be placed on the left edge of portrait pages and the top edge of landscape pages. • Short Edge specifies that binding be placed on the top edge of portrait pages and the left edge of landscape pages.
Copies 1–999	Specifies a default number of copies for each print job Note: 1 is the factory default setting.
Blank Pages Do Not Print Print	Specifies whether blank pages are inserted in a print job Note: Do Not Print is the factory default setting.
Collate Off (1,1,1,2,2,2) On (1,2,1,2,1,2)	Stacks the pages of a print job in sequence when printing multiple copies Notes: <ul style="list-style-type: none"> • Off is the factory default setting. No pages will be collated. • The On setting stacks the print job sequentially. • Both settings print the entire job the number of times specified by the Copies menu setting.
Separator Sheets None Between Copies Between Jobs Between Pages	Specifies whether blank separator sheets are inserted Notes: <ul style="list-style-type: none"> • None is the factory default setting. • Between Copies inserts a blank sheet between each copy of a print job if Collation is set to On. If Collation is set to Off, a blank page is inserted between each set of printed pages, such as after all page 1's and after all page 2's. • Between Jobs inserts a blank sheet between print jobs. • Between Pages inserts a blank sheet between each page of the print job. This setting is useful when printing transparencies or inserting blank pages in a document for notes.

Menu item	Description
Separator Source Tray <x> Multipurpose Tray	Specifies the paper source for separator sheets Notes: <ul style="list-style-type: none"> • Tray 1 (standard tray) is the factory default setting. • From the Paper menu, Configure MP must be set to Cassette in order for Multipurpose Tray to appear as a menu setting.
N-up (pages-side) Off 2-Up 3-Up 4-Up 6-Up 9-Up 12-Up 16-Up	Specifies that multiple-page images be printed on one side of a sheet of paper. Notes: <ul style="list-style-type: none"> • Off is the factory default setting. • The number selected is the number of page images that will print per side.
N-up Ordering Horizontal Reverse Horizontal Reverse Vertical Vertical	Specifies the positioning of multiple-page images when using N-up (pages-sides) Notes: <ul style="list-style-type: none"> • Horizontal is the factory default setting. • Positioning depends on the number of images and whether the images are in portrait or landscape orientation.
Orientation Auto Long Edge Short Edge	Specifies the orientation of a multiple-page sheet Notes: <ul style="list-style-type: none"> • Auto is the factory default setting. The printer chooses between portrait and landscape. • Long Edge uses landscape. • Short Edge uses portrait.
N-up Border None Solid	Prints a border around each page image when using N-up (pages-sides) Note: None is the factory default setting.

Quality menu

Menu item	Description
Print Mode Color Black Only	Specifies whether images are printed in monochrome grayscale or in color Note: Color is the factory default setting.

Menu item	Description
Color Correction Auto Off Manual	Adjusts the color output on the printed page Notes: <ul style="list-style-type: none"> • Auto is the factory default setting. Auto applies different color conversion tables to each object on the printed page. • Off turns off color correction. • Manual allows customization of the color tables using the settings available from the Manual Color menu. • Due to the differences in additive and subtractive colors, certain colors that appear on computer monitors are impossible to duplicate on the printed page.
Print Resolution 1200 dpi 4800 CQ	Specifies the printed output resolution Notes: <ul style="list-style-type: none"> • 4800 CQ is the factory default setting. • 1200 dpi provides the highest resolution output, and increases gloss.
Toner Darkness 1–5	Lightens or darkens the printed output Notes: <ul style="list-style-type: none"> • 4 is the factory default setting. • Selecting a smaller number can help conserve toner. • If Print Mode is set to Black Only, a setting of 5 increases toner density and darkness to all print jobs. • If Print Mode is set to Color, a setting of 5 is the same as a setting of 4.
Enhance Fine Lines On Off	Enables a print mode preferable for files such as architectural drawings, maps, electrical circuit diagrams, and flow charts Notes: <ul style="list-style-type: none"> • To set Enhance Fine Lines from the software program, with a document open, click File → Print, and then click Properties, Preferences, Options, or Setup. • To set Enhance Fine Lines using the Embedded Web Server, type the network printer IP address in a browser window.
Color Saver On Off	Reduces the amount of toner used for graphics and images. The amount of toner used for text is not reduced. Notes: <ul style="list-style-type: none"> • Off is the factory default setting. • On overrides Toner Darkness settings.
RGB Brightness -6–6	Adjusts brightness in color outputs Notes: <ul style="list-style-type: none"> • 0 is the factory default setting. • -6 is the maximum decrease. 6 is the maximum increase. • This does not affect files where CMYK color specifications are being used.

Menu item	Description
RGB Contrast 0–5	Adjusts contrast in color outputs Notes: <ul style="list-style-type: none"> • 0 is the factory default setting. • This does not affect files where CMYK color specifications are being used.
RGB Saturation 0–5	Adjusts saturation in color outputs Notes: <ul style="list-style-type: none"> • 0 is the factory default setting. • This does not affect files where CMYK color specifications are being used.
Color Balance Cyan –5–5 Magenta –5–5 Yellow –5–5 Black –5–5 Reset Defaults 0	Adjusts color in printed output by increasing or decreasing the amount of toner being used for each color Note: 0 is the factory default setting.
Color Samples sRGB Display sRGB Vivid Display—True Black Vivid Off—RGB US CMYK Euro CMYK Vivid CMYK Off—CMYK	Prints sample pages for each of the RGB and CMYK color conversion tables used in the printer Notes: <ul style="list-style-type: none"> • Selecting any setting prints the sample. • Color samples consist of a series of colored boxes along with the RGB or CMYK combination that creates the color observed. These pages can be used to help decide which combinations to use to get the desired printed output. • From a browser window, type the IP address of the printer to access a complete list of color sample pages from the Embedded Web Server.

Menu item	Description
<p>Manual Color</p> <p>RGB Image</p> <p> Vivid</p> <p> sRGB Display</p> <p> Display—True Black</p> <p> sRGB Vivid</p> <p> Off</p> <p>RGB Text</p> <p> Vivid</p> <p> sRGB Display</p> <p> Display—True Black</p> <p> sRGB Vivid</p> <p> Off</p> <p>RGB Graphics</p> <p> Vivid</p> <p> sRGB Display</p> <p> Display—True Black</p> <p> sRGB Vivid</p> <p> Off</p>	<p>Customizes the RGB color conversions</p> <p>Notes:</p> <ul style="list-style-type: none"> • sRGB Display is the factory default setting for RGB Image. This applies a color conversion table to an output that matches the colors displayed on a computer monitor. • sRGB Vivid is the factory default setting for RGB Text and RGB Graphics. sRGB Vivid applies a color table that increases saturation. This is preferred for business graphics and text. • Vivid applies a color conversion table that produces brighter, more saturated colors. • Display—True Black applies a color conversion table that uses only black toner for neutral gray colors. • Off turns off color conversion.
<p>Manual Color</p> <p>CMYK Image</p> <p> US CMYK</p> <p> Euro CMYK</p> <p> Vivid CMYK</p> <p> Off</p> <p>CMYK Text</p> <p> US CMYK</p> <p> Euro CMYK</p> <p> Vivid CMYK</p> <p> Off</p> <p>CMYK Graphics</p> <p> US CMYK</p> <p> Euro CMYK</p> <p> Vivid CMYK</p> <p> Off</p>	<p>Customizes the CMYK color conversions</p> <p>Notes:</p> <ul style="list-style-type: none"> • US CMYK is the US factory default setting. US CMYK applies a color conversion table that tries to produce output that matches SWOP color output. • Euro CMYK is the international factory default setting. Euro CMYK applies a color conversion table that tries to produce output that matches EuroScale color output. • Vivid CMYK increases color saturation for the US CMYK color conversion table. • Off turns off color conversion.
<p>Color Adjust</p>	<p>Initiates a recalibration of color conversion tables and allows the printer to make adjustments for color variations in output</p> <p>Notes:</p> <ul style="list-style-type: none"> • Calibrating starts when the menu is selected. Calibrating appears on the display until the process is finished. • Color variations in output sometimes result from changeable conditions such as room temperature and humidity. Color adjustments are made on printer algorithms. Color alignment is also recalibrated in this process.

Utilities menu

Menu item	Description
Remove Held Jobs Confidential Held Not Restored All	Removes confidential and held jobs from the printer hard disk Notes: <ul style="list-style-type: none"> • Selecting a setting affects only print jobs that are resident in the printer. Bookmarks, jobs on flash drives, and other types of held jobs are not affected. • Selecting Not Restored removes all Print and Hold jobs that were <i>not</i> restored from the disk.
Format Flash Yes No	Formats the flash memory. Flash memory refers to the memory added by installing a flash memory option card in the printer. Warning—Potential Damage: Do not turn off the printer while the flash memory is formatting. Notes: <ul style="list-style-type: none"> • A flash memory option card must be installed in the printer and operating properly for this menu item to be available. The flash memory option card must not be Read/Write or Write protected. • Selecting Yes deletes all data stored in flash memory. • No cancels the format request.
Delete Downloads on Disk Delete Now Do Not Delete	Removes downloads from the printer hard disk, including all held Jobs, buffered jobs, and parked jobs. Job accounting information is not affected. Note: Delete Now is the default setting.
Job Acct Stat Print Clear	Prints a list of all stored job statistics or deletes the information from the printer hard disk Notes: <ul style="list-style-type: none"> • A printer hard disk must be installed in the printer and operating properly for this menu item to be available. • Selecting Print prints a list of statistics. • Clear deletes all job statistics stored on the printer hard disk. • The Clear selection will not appear if Job Accounting is set to MarkTrack™ using NPA.
Hex Trace Activate	Assists in isolating the source of a print job problem Notes: <ul style="list-style-type: none"> • When Activate is selected, all data sent to the printer is printed in hexadecimal and character representation and control codes are not executed. • To exit or deactivate Hex Trace, turn the printer off or reset the printer.
Coverage Estimator Off On	Provides an estimate of the percentage coverage of black on a page. The estimate is printed on a separate page at the end of each print job. Note: Off is the factory default setting.

Menu item	Description
LCD Contrast 1–10	Adjusts the contrast lighting of the display Notes: <ul style="list-style-type: none"> • 5 is the factory default setting. • A higher setting makes the display appear lighter. • A lower setting makes the display appear darker.
LCD Brightness 1–10	Adjusts the brightness of the backlight on the display Notes: <ul style="list-style-type: none"> • 5 is the factory default setting. • A higher setting makes the display appear lighter. • A lower setting makes the display appear darker.

XPS menu

Menu item	Description
Print Error Pages Off On	Prints a page containing information on errors, including XML markup errors Note: Off is the factory default setting.

PDF menu

Menu item	Description
Scale to Fit Yes No	Scales page content to fit the selected paper size Note: No is the factory default setting.
Annotations Do Not Print Print	Prints annotations in a PDF Note: Do Not Print is the factory default setting.

PostScript menu

Menu item	Description
Print PS Error On Off	Prints a page containing the PostScript error Note: Off is the factory default setting.

Menu item	Description
Font Priority Resident Flash/Disk	Establishes the font search order Notes: <ul style="list-style-type: none"> • Resident is the factory default setting. • A formatted flash memory option card or printer hard disk must be installed in the printer and operating properly for this menu item to be available. • The flash memory option or printer hard disk cannot be Read/Write, Write, or password protected. • Job Buffer Size must not be set to 100%.
Image Smoothing On Off	Enhances the contrast and sharpness of low-resolution images and smooths their color transitions Notes: <ul style="list-style-type: none"> • Off is the factory default setting. • Image Smoothing has no effect on images that are 300 dpi or higher in resolution.

PCL Emul menu

Menu item	Description
Font Source Resident Disk Flash Download All	Specifies the set of fonts used by the Font Name menu item Notes: <ul style="list-style-type: none"> • Resident is the factory default setting. It shows the factory default set of fonts downloaded into RAM. • Flash and Disk settings show all fonts resident in that option. • Flash option must be properly formatted and cannot be Read/Write, Write, or password protected. • Download shows all the fonts downloaded into RAM. • All shows all fonts available to any option.
Font Name RO Courier	Identifies a specific font and the option where it is stored Notes: <ul style="list-style-type: none"> • RO Courier is the factory default setting. • RO Courier shows the font name, font ID, and storage location in the printer. The font source abbreviation is R for Resident, F for Flash, K for Disk, and D for download.

Menu item	Description
Symbol Set 10U PC-8 12U PC-850	Specifies the symbol set for each font name Notes: <ul style="list-style-type: none"> • 10U PC-8 is the US factory default setting. • 12U PC-850 is the international factory default setting. • A symbol set is a set of alphabetic and numeric characters, punctuation, and special symbols. Symbol sets support the different languages or specific programs such as math symbols for scientific text. Only the supported symbol sets are shown.
PCL Emulation Settings Point Size 1.00–1008.00	Changes the point size for scalable typographic fonts Notes: <ul style="list-style-type: none"> • 12 is the factory default setting. • Point Size refers to the height of the characters in the font. One point equals approximately 1/72 of an inch. • Point sizes can be increased or decreased in 0.25-point increments.
PCL Emulation Settings Pitch 0.08–100	Specifies the font pitch for scalable monospaced fonts Notes: <ul style="list-style-type: none"> • 10 is the factory default setting. • Pitch refers to the number of fixed-space characters per inch (cpi). • Pitch can be increased or decreased in 0.01-cpi increments. • For nonscalable monospaced fonts, the pitch appears on the display but cannot be changed.
PCL Emulation Settings Orientation Portrait Landscape	Specifies the orientation of text and graphics on the page Notes: <ul style="list-style-type: none"> • Portrait is the factory default setting. • Portrait prints text and graphics parallel to the short edge of the page. • Landscape prints text and graphics parallel to the long edge of the page.
PCL Emulation Settings Lines per Page 1–255 60 64	Specifies the number of lines that print on each page Notes: <ul style="list-style-type: none"> • 60 is the US factory default setting. 64 is the international default setting. • The printer sets the amount of space between each line based on the Lines per Page, Paper Size, and Orientation settings. Select the desired Paper Size and Orientation before setting Lines per Page.
PCL Emulation Settings A4 Width 198 mm 203 mm	Sets the printer to print on A4-size paper Notes: <ul style="list-style-type: none"> • 198 mm is the factory default setting. • The 203-mm setting sets the width of the page to allow the printing of eighty 10-pitch characters.

Menu item	Description
PCL Emulation Settings Auto CR after LF On Off	Specifies whether the printer automatically performs a carriage return (CR) after a line feed (LF) control command Notes: <ul style="list-style-type: none"> • Off is the factory default setting. • Setting alterations are duplicated in the PPDS menu.
PCL Emulation Settings Auto LF after CR On Off	Specifies whether the printer automatically performs a line feed (LF) after a carriage return (CR) control command Notes: <ul style="list-style-type: none"> • Off is the factory default setting. • Setting alterations are duplicated in the PPDS menu.
Tray Renumber Assign MP Feeder Off None 0–199 Assign Tray <x> Off None 0–199 Assign Manual Paper Off None 0–199 Assign Man Env Off None 0–199	Configures the printer to work with printer software or programs that use different source assignments for trays, drawers, and feeders Notes: <ul style="list-style-type: none"> • Off is the factory default setting. • None is not an available selection. It is only displayed when it is selected by the PCL 5 interpreter. • None ignores the Select Paper Feed command. • 0–199 allows a custom setting to be assigned.
Tray Renumber View Factory Def None	Displays the factory default setting assigned to each tray, drawer, or feeder
Tray Renumber Restore Defaults Yes No	Returns all tray, drawer, and feeder assignments to the factory default settings

HTML menu

Menu item		Description
Font Name Albertus MT Antique Olive Apple Chancery Arial MT Avant Garde Bodoni Bookman Chicago Clarendon Cooper Black Copperplate Coronet Courier Eurostile Garamond Geneva Gill Sans Goudy Helvetica Hoefler Text	Intl CG Times Intl Courier Intl Univers Joanna MT Letter Gothic Lubalin Gothic Marigold MonaLisa Recut Monaco New CenturySbk New York Optima Oxford Palatino StempelGaramond Taffy Times TimesNewRoman Univers Zapf Chancery	Sets the default font for HTML documents Note: The Times font will be used in HTML documents that do not specify a font.

Menu item	Description
Font Size 1–255 pt	Sets the default font size for HTML documents Notes: <ul style="list-style-type: none"> • 12 pt is the factory default setting. • Font size can be increased in 1-point increments.
Scale 1–400%	Scales the default font for HTML documents Notes: <ul style="list-style-type: none"> • 100% is the factory default setting. • Scaling can be increased in 1% increments.
Orientation Portrait Landscape	Sets the page orientation for HTML documents Note: Portrait is the factory default setting.
Margin Size 8–255 mm	Sets the page margin for HTML documents Notes: <ul style="list-style-type: none"> • 19 mm is the factory default setting. • Margin size can be increased in 1-mm increments.

Menu item	Description
Backgrounds Do Not Print Print	Specifies whether to print backgrounds on HTML documents Note: Print is the factory default setting.

Image menu

Menu item	Description
Auto Fit On Off	Selects the optimal paper size, scaling, and orientation Notes: <ul style="list-style-type: none"> • On is the factory default setting. • The On setting overrides scaling and orientation settings for some images.
Invert On Off	Inverts bi-tonal monochrome images Notes: <ul style="list-style-type: none"> • Off is the factory default setting. • This setting does not apply to GIF or JPEG images.
Scaling Anchor Top Left Best Fit Anchor Center Fit Height/Width Fit Height Fit Width	Scales the image to fit the selected paper size Notes: <ul style="list-style-type: none"> • Best Fit is the factory default setting. • When Auto Fit is set to On, Scaling is automatically set to Best Fit.
Orientation Portrait Landscape Rev Portrait Rev Landscape	Sets the image orientation Note: Portrait is the factory default setting.

PictBridge menu

Menu item	Description
Photo Size Auto L 2L Hagaki Postcard Card Size 100x150 mm 4x6 inches 8x10 inches Letter A4 A5 JIS B5	Selects the optimal photo size Notes: <ul style="list-style-type: none"> • Auto is the factory default setting. • If both the printer and the PictBridge-enabled camera have a value for this setting, the camera value <i>always</i> supersedes the printer value.
Layout Auto Off 2 Up 3 Up 4 Up 6 Up 9 Up 12 Up 16 Up Index Print	Selects the optimal photo layout Notes: <ul style="list-style-type: none"> • Auto is the factory default setting. • If both the printer and the PictBridge-enabled camera have a value for this setting, the camera value <i>always</i> supersedes the printer value.
Quality Normal Draft Fine	Selects the optimal quality Notes: <ul style="list-style-type: none"> • Normal is the factory default setting. • If both the printer and the PictBridge-enabled camera have a value for this setting, the camera value <i>always</i> supersedes the printer value.
Paper Source Multipurpose tray Tray <x> Manual Paper	Sets the tray the paper pulls from Notes: <ul style="list-style-type: none"> • Multipurpose tray is the factory default setting. • If both the printer and the PictBridge-enabled camera have a value for this setting, the camera value <i>always</i> supersedes the printer value.

Flash Drive menu

Menu item	Description
Copies 1–999	Specifies a default number of copies for each print job Note: 1 is the factory default setting.

Menu item	Description
Paper Source Tray <x> Manual Feeder Envelope Feeder	Sets a default paper source for all print jobs Note: Tray 1 (standard tray) is the factory default setting.
Collate Off (1,1,1,2,2,2) On (1,2,1,2,1,2)	Stacks the pages of a print job in sequence when printing multiple copies Notes: <ul style="list-style-type: none"> • Off is the factory default setting. No pages will be collated. • The On setting stacks the print job sequentially.
Sides (Duplex) 2 sided 1 sided	Controls whether the job prints on one side or both sides of the paper Note: 1 sided is the factory default setting.
Duplex Binding Long Edge Short Edge	Defines the way duplexed pages are bound and how the printing on the back of the page is oriented in relation to the printing on the front of the page Notes: <ul style="list-style-type: none"> • Long Edge is the factory default setting. • Long Edge specifies that binding be placed on the left edge of portrait pages and the top edge of landscape pages. • Short Edge specifies that binding be placed on the top edge of portrait pages and the left edge of landscape pages.
Orientation Auto Long Edge Short Edge	Specifies the orientation of a multiple-page sheet Notes: <ul style="list-style-type: none"> • Auto is the factory default setting. The printer chooses between portrait and landscape. • Long Edge uses landscape. • Short Edge uses portrait.
N-up (pages-side) Off 2-Up 3-Up 4-Up 6-Up 9-Up 12-Up 16-Up	Specifies that multiple-page images be printed on one side of a sheet of paper Notes: <ul style="list-style-type: none"> • Off is the factory default setting. • The number selected is the number of page images that will print per side.
N-up Border None Solid	Prints a border around each page image when using N-up (pages-side) Note: None is the factory default setting.

Menu item	Description
N-up Ordering Horizontal Reverse Horizontal Reverse Vertical Vertical	Specifies the positioning of multiple-page images when using N-up (pages-side) Notes: <ul style="list-style-type: none"> Horizontal is the factory default setting. Positioning depends on the number of images and whether the images are in portrait or landscape orientation.
Separator Sheets None Between Copies Between Jobs Between Pages	Specifies whether blank separator sheets are inserted Notes: <ul style="list-style-type: none"> None is the factory default setting. Between Copies inserts a blank sheet between each copy of a print job if Collation is set to On. If Collation is set to Off, then a blank page is inserted between each set of printed pages, such as after all page 1's and after all page 2's. Between Jobs inserts a blank sheet between print jobs. Between Pages inserts a blank sheet between each page of the print job. This setting is useful when printing transparencies or inserting blank pages in a document for notes.
Separator Source Tray <x> Multi-Purpose Feeder Envelope Feeder	Specifies the paper source for separator sheets Notes: <ul style="list-style-type: none"> Tray 1 (standard tray) is the factory default setting. From the Paper menu, Configure MP must be set to Cassette in order for Multi-Purpose Feeder to appear as a menu setting.
Blank Pages Do Not Print Print	Specifies whether blank pages are inserted in a print job Note: Do Not Print is the factory default setting.

Help menu

The Help menu consists of a series of Help pages that are stored in the printer as PDFs. They contain information about using the printer and performing printing tasks.

English, French, German, and Spanish translations are stored in the printer. Other translations are available on the *Software and Documentation CD*.

Menu item	Description
Print All	Prints all the guides
Color Quality Guide	Provides information about adjusting and customizing color printing
Print Quality Guide	Provides information about solving print quality issues
Printing Guide	Provides information about loading paper and other speciality media
Supplies Guide	Provides part numbers for ordering supplies
Media Guide	Provides a list of the paper sizes supported in trays, drawers, and feeders
Print Defects Guide	Provides help in determining the printer part causing a repetitive defect

Menu item	Description
Menu Map	Provides a list of the printer control panel menus and settings
Information Guide	Provides help in locating additional information
Connection Guide	Provides information about connecting the printer locally (USB) or to a network
Moving Guide	Provides instructions for safely moving the printer

Understanding printer messages

When **Manual Feeder** appears on the display, it refers to the multipurpose tray, which is also referred to as the multipurpose feeder.

List of status and error messages

Activating Menu Changes

Wait for the message to clear.

Busy

Wait for the message to clear.

Calibrating

Wait for the message to clear.

Cancel not available

Wait for the message to clear.

Canceling

Wait for the message to clear.

Change <src> to <x>

- Press the down arrow button until **Continue** appears, and then press if the paper was changed.
- Press the down arrow button until **Use Current** appears, and then press the down arrow button to print on the paper currently in the printer.
- Cancel the current print job.
- For more information, select **Show Me**.

Clearing job accounting statistics

Wait for the message to clear.

Close door <x>

- 1 Press the down arrow button until **Show me** appears, and then press .
An image of the open door appears.
- 2 Close the specified door.

Copies

Enter the desired number of copies.

Defragmenting Flash DO NOT POWER OFF

Wait for the message to clear.

Warning—Potential Damage: Do not turn the printer off while this message appears on the display.

Delete/Delete all/Delete all confidential jobs

- Press the down arrow button until **CONTINUE** appears, and then press to delete the specified job.
- Press to delete the job.

Deleting

Wait for the message to clear.

Disabling DLEs

Wait for the message to clear.

Disabling Menus

Wait for the message to clear.

Note: While the menus are disabled, printer settings cannot be changed from the control panel.

Disk Corrupted. Reformat?

The printer attempted to recover a disk, but was not able to do so. **Reformat** appears. Press to reformat the disk.

Note: Reformatting the disk deletes all the files currently stored on the disk.

Disk recovery x/y XX% DO NOT POWER OFF

Wait for the message to clear.

Warning—Potential Damage: Do not power off while the printer is attempting to recover the printer hard disk.

Disk recovery takes place in several phases. The percentage completed during each phase appears on the display.

Enabling Menus

Wait for the message to clear.

Encrypting disk x/y XX% DO NOT POWER OFF

Wait for the message to clear.

Warning—Potential Damage: Do not power off while the printer is encrypting the printer hard disk.

The percentage completed appears on the display.

Enter PIN

Enter the PIN you created in Print Properties when the confidential job was sent for printing.

Enter PIN to lock

Enter the PIN you created to lock the control panel and prevent menu changes.

Flushing buffer

Wait for the message to clear.

Formatting Disk x/y XX% DO NOT POWER OFF

Wait for the message to clear.

Warning—Potential Damage: Do not power off while the printer is formatting the printer hard disk.

The percentage completed appears on the display.

Formatting Flash DO NOT POWER OFF

Wait for the message to clear.

Warning—Potential Damage: Do not power off while the printer is formatting the flash memory.

Insert Tray <x>

Insert the specified tray into the printer.

Internal System Error, Reload Bookmarks

- 1 Press the down arrow button until **CONTINUE** appears, and then press to clear the message and continue printing.
- 2 Reload the bookmarks.

Internal System Error, Reload Security Certificates

- Reload the security certificates.
- Press the down arrow button until **CONTINUE** appears, and then press to clear the message and continue printing.

Invalid Engine Code

You need to download valid engine code for the printer.

For more information, visit the Lexmark Web site at www.lexmark.com, or contact customer support.

Note: Engine code may be downloaded while this message appears on the display.

Invalid Network Code

You need to download valid network printing code for the internal print server. The internal print server is a hardware option installed inside the printer.

Note: Network code may be downloaded while this message appears on the display.

Invalid PIN

Enter a valid PIN.

Load multipurpose tray with <x>

- Load the specified paper in the multipurpose tray.

Note: To learn how to load the multipurpose tray, press the down arrow button until **Show Me** appears, and then press .

- Press the down arrow button until **Continue** appears, and then press to clear the message and continue printing.

If the printer finds a tray that has the correct paper type and size, then it feeds from that tray. If the printer cannot find a tray with the correct paper type and size, then it prints from the default source.

- Cancel the current job.

Load <src> with <x>

- Load the paper tray or other source with the correct paper type and size.

Note: To learn how to load the specified paper source, press the down arrow button until **Show Me** appears, and then press .

- Cancel the current job.

Menus are disabled

The printer menus are disabled. The printer settings cannot be changed from the printer control panel. Contact your system support person for help.

Note: When menus are disabled, it is still possible to cancel a print job, print a confidential job, or print a held job.

Network/Network <x>

The printer is connected to the network.

Network indicates that the printer is using the standard network port built into the printer system board. **Network <x>** indicates that an internal print server is installed inside the printer or that the printer is connected to an external print server.

No held jobs

Wait for the message to clear.

No jobs to cancel

Wait for the message to clear.

Power Saver

The printer is saving power while it waits for the next print job.

- Send a job to print.
- Press to warm the printer to normal operating temperature. Afterwards, **Ready** appears.

Printer locked, enter PIN to unlock

The control panel is locked. Enter the correct PIN to unlock it.

Printing

Wait for the message to clear.

Programming disk DO NOT POWER OFF

Wait for the message to clear.

Warning—Potential Damage: Do not turn the printer power off while **Programming disk** appears on the display.

Programming flash DO NOT POWER OFF

Wait for the message to clear.

Warning—Potential Damage: Do not turn the printer power off while **Programming flash** appears on the display.

Programming System Code DO NOT POWER OFF

Wait for the message to clear.

Warning—Potential Damage: Do not turn the printer power off while **Programming System Code** appears on the display.

Reading USB drive DO NOT REMOVE

Wait for the message to clear.

Ready

The printer is ready to receive print jobs.

Remote Management Active DO NOT POWER OFF

The printer settings are being configured. Wait for the message to clear.

Warning—Potential Damage: Do not turn the printer power off while **Remote Management Active** appears on the display.

Remove all color supplies

The printer is set for Color Lock Out printing in the Config menu. Try one of the following methods:

- Remove all color toner cartridges and photoconductor units.
 - Note:** Do *not* remove the black toner cartridge or photoconductor unit.
- Press the down arrow button until **Continue** appears, and then press to clear the message and print in Color Lock Out mode.

Remove Packaging Materials

- 1 Remove all packing material from the printer.
- 2 Make sure the fuser, transfer module, trays, and supplies are installed correctly.
- 3 Press the down arrow button until **Show Areas** appears, and then press .

A tutorial appears on the display indicating the actions you need to take to complete setup.

Remove paper from standard bin

The standard exit bin has reached its capacity. Remove paper from the standard exit bin to clear the message and continue printing.

Resetting Fuser Count

Wait for the message to clear.

Resetting the printer

Wait for the message to clear.

Restore Held Jobs?

- Press the down arrow button until **Continue** appears, and then press to restore all held jobs stored on the printer hard disk.
- Press the down arrow button until **Do not restore** appears, and then press . No print jobs will be restored.

Restoring Factory Defaults

Wait for the message to clear.

When factory default settings are restored:

- All downloaded resources in the printer memory are deleted. This includes fonts, macros, and symbol sets.
- All settings return to the factory defaults except the Display Language setting in the Setup menu and the custom settings in the Serial <x>, Network, Infrared, LocalTalk, and USB menus.

Restoring Held Job(s) x/y

- Wait for the message to clear.
- Press the down arrow button until \checkmark Quit restoring appears, and then press \checkmark to delete unrestored held jobs.

Note: x represents the number of jobs being restored. y represents the total number of jobs to be restored.

Serial <x>

The printer is using a serial cable connection. The serial port is the active communication link.

Some held jobs were not restored

Press the down arrow button until \checkmark Continue appears, and then press \checkmark to delete the specified job.

Some held jobs will not be restored

- Press the down arrow button until \checkmark Continue appears, and then press \checkmark to clear the message and resume printing.
- Cancel the current job.

Standard Bin Full

Remove the stack of paper from the standard exit bin to clear the message.

Submitting Selection

Wait for the message to clear.

Tray <x> Empty

Load paper in the tray to clear the message.

Tray <x> Low

Load paper in the specified tray to clear the message.

Tray <x> Missing

Insert the specified tray into the printer.

USB/USB <x>

The printer is using a USB cable connection. The USB port is the active communication link.

Waiting

The printer has received data to print, but is waiting for an End-of-Job command, a Form Feed command, or additional data.

- Press to print the contents of the buffer.
- Cancel the current print job.

31 Missing or defective <color> cartridge

The specified toner cartridge is either missing or not functioning properly.

- Remove the specified toner cartridge, and then reinstall it.
- Remove the specified toner cartridge, and then install a new one.

32 Replace unsupported <color> cartridge

Remove the specified toner cartridge, and then install a supported one.

34 Incorrect paper type, check <src>

- Load the appropriate paper or other specialty media in the proper tray.
- Check tray length and width guides, and make sure the paper is properly loaded in the tray.
- Check the Print Properties settings to make sure the print job is requesting the correct paper size and type.
- Check that the paper size is correctly set. For example, if the Multipurpose Tray Size is set to Universal, make sure the paper is large enough for the data being printed.
- Cancel the current print job.

34 Incorrect paper size, check <src>

- Load the appropriate paper or other specialty media in the proper tray.
- Press the down arrow button until **Continue** appears, and then press to clear the message and print the job using a different paper tray.
- Check tray length and width guides, and make sure the paper is properly loaded in the tray.
- Check the Print Properties settings to make sure the print job is requesting the correct paper size and type.
- Check that the paper size is correctly set. For example, if the Multipurpose Tray Size is set to Universal, make sure the paper is large enough for the data being printed.
- Cancel the current print job.

34 Short paper

Try one or more of the following:

- Load the appropriate paper in the tray.
- Press the down arrow button until **Continue** appears, and then press to clear the message and print the job using a different paper tray.
- Check the tray length and width guides, and make sure the paper is properly loaded in the tray.
- Check the Print Properties settings to make sure the print job is requesting the correct paper size and type.

- Check that the paper size is correctly set. For example, if the Multipurpose Tray Size is set to Universal, then make sure the paper is large enough for the data being printed.
- Cancel the current print job.

35 Insufficient memory to support Resource Save feature

- Press the down arrow button until **Continue** appears, and then press to disable Resource Save and continue printing.
- To enable Resource Save after receiving this message, make sure the link buffers are set to Auto, and then exit the menus to activate the link buffer changes. When **Ready** appears, enable Resource Save.
- Install additional memory.

37 Insufficient memory for Flash Memory Defragment operation

- Press the down arrow button until **Continue** appears, and then press to stop the defragment operation and continue printing.
- Delete fonts, macros, and other data in printer memory.
- Install additional printer memory.

37 Insufficient memory to collate job

- Press the down arrow button until **Continue** appears, and then press to print the portion of the job already stored and begin collating the rest of the print job.
- Cancel the current print job.

37 Insufficient memory, some held jobs will not be restored

The printer was unable to restore some or all of the confidential or held jobs on the printer hard disk.

Press the down arrow button until **Continue** appears, and then press to clear the message.

38 Memory full

- Press the down arrow button until **Continue** appears, and then press to clear the message.
- Cancel the current print job.
- Install additional printer memory.

39 Page is too complex to print

- Press the down arrow button until **Continue** appears, and then press to clear the message and continue printing.
- Cancel the current print job.
- Install additional printer memory.

51 Defective flash detected

- Press the down arrow button until **Continue** appears, and then press to clear the message and continue printing.
- Cancel the current print job.

52 Flash full

- Press the down arrow button until **Continue** appears, and then press to clear the message and continue printing.
Downloaded fonts and macros not previously stored in flash memory are deleted.
- Delete fonts, macros, and other data stored in flash memory.
- Upgrade to a larger capacity flash memory card.

53 Unformatted flash detected

- Press the down arrow button until **Continue** appears, and then press to stop the defragment operation and continue printing.
- Format the flash memory. If the error message remains, the flash memory may be defective and require replacing.

54 Network <x> software error

- Press the down arrow button until **Continue** appears, and then press to continue printing.
- Turn the printer power off and then back on to reset the printer.
- Upgrade (flash) the network firmware in the printer or print server.

54 Serial option <x> error

- Check that the serial cable is connected correctly and is the proper one for the serial port.
- Check that the serial interface parameters (protocol, baud, parity, and data bits) are set correctly on the printer and host computer.
- Press the down arrow button until **Continue** appears, and then press to continue printing.
- Turn the printer power off and then back on to reset the printer.

54 Standard network software error

- Press the down arrow button until **Continue** appears, and then press to continue printing.
- Turn the printer power off and then back on to reset the printer.
- Upgrade (flash) the network firmware in the printer or print server.

55 Unsupported option in slot <x>

- 1 Turn the printer power off.
- 2 Unplug the power cord from the wall outlet.
- 3 Remove the unsupported optional interface card or internal print server from the printer system board.
- 4 Connect the power cord to a properly grounded outlet.
- 5 Turn the printer power back on.

56 Parallel port <x> disabled

- Press the down arrow button until **Continue** appears, and then press to clear the message.
The printer discards any data received through the parallel port.
- Make sure the Parallel Buffer menu item is not set to Disabled.

56 Serial port <x> disabled

- Press the down arrow button until **Continue** appears, and then press to clear the message.
The printer discards any data received through the serial port.
- Make sure the Serial Buffer menu item is not set to Disabled.

56 Standard USB port disabled

- Press the down arrow button until **Continue** appears, and then press to clear the message.
The printer discards any data received through the USB port.
- Make sure the USB Buffer menu item is not set to Disabled.

56 USB port <x> disabled

- Press the down arrow button until **Continue** appears, and then press to clear the message.
The printer discards any data received through the USB port.
- Make sure the USB Buffer menu item is not set to Disabled.

57 Configuration change, held jobs were not restored

Press the down arrow button until **Continue** appears, and then press to clear the message.

58 Too many flash options installed

- 1 Turn the printer power off.
- 2 Unplug the power cord from the wall outlet.
- 3 Remove the excess flash memory.
- 4 Connect the power cord to a properly grounded outlet.
- 5 Turn the printer power back on.

58 Too many trays attached

- 1 Turn the printer power off.
- 2 Unplug the power cord from the wall outlet.
Note: Optional trays lock together when stacked. Remove stacked trays one at a time from the top down.
- 3 Remove the additional trays.
- 4 Connect the power cord to a properly grounded outlet.
- 5 Turn the printer power back on.

61 Remove defective hard disk

- Press the down arrow button until **Continue** appears, and then press to clear the message and continue printing.
- Install a different hard disk before performing any operations that require a hard disk.

62 Disk full

- Press the down arrow button until **Continue** appears, and then press to clear the message and continue processing.
- Delete fonts, macros, and other data stored on the hard disk.
- Install a larger hard disk.

63 Unformatted disk

- Press the down arrow button until **Continue** appears, and then press to clear the message and continue printing.
- Format the disk.

If the error message remains, the hard disk may be defective and require replacing.

80 Fuser life warning

- Press the down arrow button until **Continue** appears, and then press to clear the message and continue printing.
- Order a replacement fuser immediately. When print quality is reduced, install the new fuser using the instruction sheet that came with the replacement part.

80 Replace fuser

Replace the fuser using the instruction sheet that came with the replacement part.

82 Replace waste toner box

The waste toner box is full.

- 1 Replace the waste toner box using the instruction sheet that came with the replacement part.
- 2 Clear the paper path.

82 Waste toner box missing

Reinsert the waste toner box into the printer.

82 Waste toner box nearly full

Order a replacement waste toner box immediately.

- To learn how to insert a waste toner box, press the down arrow button until **Show Me** appears, and then press .
- Press the down arrow button until **Continue** appears, and then press to clear the message and continue printing.

83 Replace transfer module

Replace the transfer module using the instruction sheet that came with the replacement part.

83 Transfer module life warning

- Press the down arrow button until **✓ Continue** appears, and then press .
- Order a replacement transfer module immediately. When print quality is reduced, install the new transfer module using the instruction sheet that came with the replacement part.

83 Transfer module missing

Insert the transfer module into the printer.

84 <color> photoconductor low

- 1 Press the down arrow button until **✓ Continue** appears, and then press .
- 2 Order a replacement photoconductor immediately. When print quality is reduced, install the new photoconductor using the instruction sheet that came with the replacement part.

84 <color> photoconductor nearly low

- 1 Press the down arrow button until **✓ Continue** appears, and then press .
- 2 Order a replacement photoconductor immediately. When print quality is reduced, install the new photoconductor using the instruction sheet that came with the replacement part.

84 Replace <color> photoconductor

Replace the specified color photoconductor using the instruction sheet that came with the replacement part.

88 <color> cartridge low

When this message appears, the toner is low. When the print becomes faded, replace the specified toner cartridge.

- To clear this message and continue printing, press the down arrow button until **✓ Continue** appears, and then press .

88 <color> cartridge nearly low

When this message appears, the toner is low. When the print becomes faded, replace the specified toner cartridge.

- To clear this message and continue printing, press the down arrow button until **✓ Continue** appears, and then press .

88 Replace <color> cartridge

- 1 The toner cartridge is exhausted. Replace the specified toner cartridge.

Note: To learn how to replace a toner cartridge, press the down arrow until **Show Me** appears, and then press .

- 2 Clear the paper path to clear the message and continue printing.

200–250.yy Paper jam

- 1 Clear the paper path.
- 2 After clearing the paper path, press to resume printing.

900–999 Service <message>

- 1 Turn the printer off.
- 2 Unplug the power cord from the wall outlet.
- 3 Check all cable connections.
- 4 Connect the power cord to a properly grounded outlet.
- 5 Turn the printer back on.

If the service message appears again, contact Customer Support, and report the message.

1565 Emul Error Load Emul Option

The printer automatically clears the message in 30 seconds and then disables the download emulator on the firmware card.

To fix this, download the correct download emulator version from the Lexmark Web site at www.lexmark.com.

Maintaining the printer

Periodically, certain tasks are required to maintain optimum print quality.

Cleaning the exterior of the printer

- 1 Make sure that the printer is turned off and unplugged from the wall outlet.



CAUTION—SHOCK HAZARD: To avoid the risk of electric shock when cleaning the exterior of the printer, unplug the power cord from the wall outlet and disconnect all cables to the printer before proceeding.

- 2 Remove paper from the standard exit bin.

- 3 Dampen a clean, lint-free cloth with water.

Warning—Potential Damage: Do not use household cleaners or detergents, as they may damage the finish of the printer.

- 4 Wipe only the outside of the printer, making sure to include the standard exit bin.

Warning—Potential Damage: Using a damp cloth to clean the interior may cause damage to your printer.

- 5 Make sure the paper support and standard exit bin are dry before beginning a new print job.

Cleaning the printhead lenses

Clean the printhead lenses when you encounter print quality problems.

- 1 Open the front door.



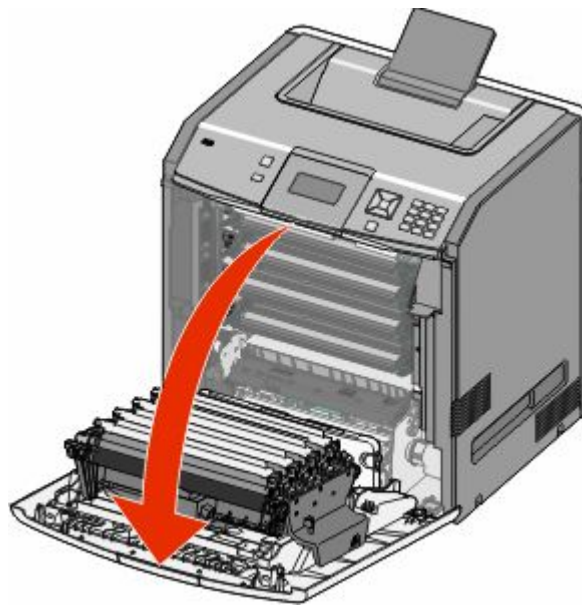

Warning—Potential Damage: To avoid overexposing the photoconductor units, do not leave the front door open for more than 10 minutes.

- 2 Remove all four toner cartridges. Do not remove the photoconductor units for this procedure.
- 3 Locate the four printhead lenses.

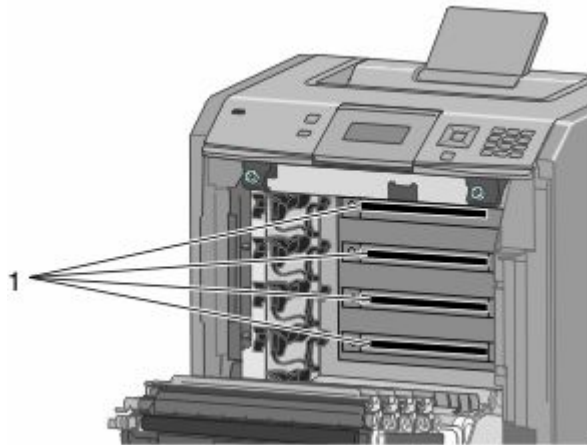

- 4 Clean the lenses using a can of compressed air.

Warning—Potential Damage: Do not touch the printhead lenses.

- 5 Reinstall the four toner cartridges.

6 Close the front door.

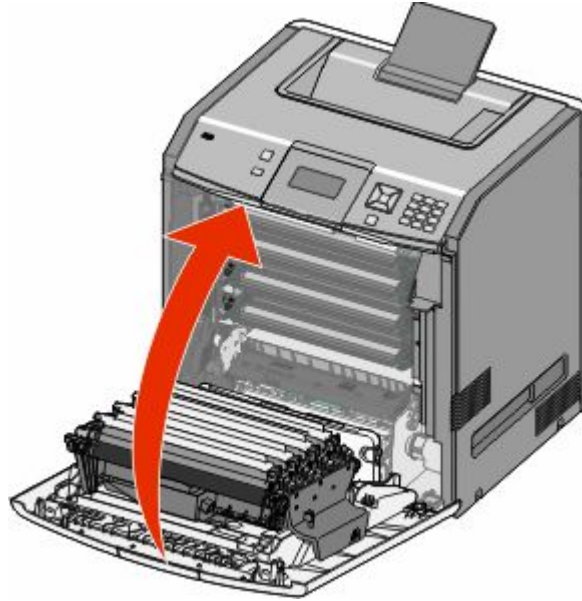

Storing supplies

Choose a cool, clean storage area for the printer supplies. Store supplies right side up in their original packing until you are ready to use them.

Do not expose supplies to:

- Direct sunlight
- Temperatures above 35°C (95°F)
- High humidity above 80%
- Salty air
- Corrosive gases
- Heavy dust

Checking the status of supplies

A message appears on the display when a replacement supply item is needed or when maintenance is required.

Checking the status of supplies from the printer control panel

- 1 Make sure the printer is on and **Ready** appears.
- 2 From the printer control panel, press the down arrow button until **✓ Status / Supplies** appears, and then press **✓**.
- 3 Press the down arrow button until **✓ View supplies** appears, and then press **✓**.
The status of each supply appears.

Checking the status of supplies from a network computer

Note: The computer must be connected to the same network as the printer.

- 1 Open a Web browser.
- 2 In the address bar, type the IP address of the network printer (for example, 192.264.263.17).
- 3 Press **Enter**.

The Device Status Page appears. A summary of supply levels is displayed.

Ordering supplies

To order supplies in the U.S., contact Lexmark at 1-800-539-6275 for information about Lexmark authorized supplies dealers in your area. In other countries or regions, visit the Lexmark Web Site at www.lexmark.com or contact the place where you purchased the printer.

Note: All life estimates for printer supplies assume printing on letter- or A4-size plain paper.

Ordering toner cartridges

When **88 Cyan cartridge low**, **88 Magenta cartridge low**, **88 Yellow cartridge low**, or **88 Black cartridge low** appears, order a new cartridge.

When **88 Replace Cyan cartridge**, **88 Replace Magenta cartridge**, **88 Replace Yellow cartridge**, or **88 Replace Black cartridge** appears, you *must* replace the specified cartridge.

Estimated cartridge yield is based on the ISO / IEC 19798 standard (with about 5% coverage per color). Extremely low print coverage (less than 1.25% for a color) for extended periods of time may negatively affect actual yield for that color and may cause cartridge parts to fail prior to exhaustion of toner.

Ordering photoconductors

When **84 photoconductor low**, or **84 <color> photoconductor nearly low** appears, order a replacement photoconductor.

When **84 Replace <color> photoconductor** appears, you *must* replace the specified photoconductor.

Part name	Part number
Photoconductor	C734X20G
Photoconductor, Multi-Pack	C734X24G

Ordering a fuser or a transfer module

When **80 Fuser Life Warning** or **83 Transfer Module Life Warning** appears, order a replacement fuser or a transfer module.

When **80 Replace Fuser** or **83 Replace Transfer Module** appears, install the new fuser or the new transfer module. For installation information, see the documentation that came with the part.

Part name	Part number
Fuser	40X5095 (100 volt) 40X5093 (115 volt) 40X5094 (230 volt)
Transfer Module	40X5096

Ordering a waste toner box

When **82 Waste toner box nearly full** appears, order a replacement waste toner box. When **82 Replace waste toner box** appears, you *must* replace the waste toner box.

Note: Waste toner box reuse is not recommended.

Part name	Part number
Waste Toner Box	C734X77G

Replacing Supplies

Replacing a photoconductor

There are three different display messages which may appear when a photoconductor replacement is necessary: **84 Replace <color> photoconductor**, **84 <color> photoconductor nearly low**, or **84 <color> photoconductor low**.

Note: A replacement photoconductor can be used with any color.

Replacing a photoconductor is a two-part process. First, complete the illustrated steps to replace the photoconductor, and then reset the life count and clear printer messages.

- 1 Open the front door.

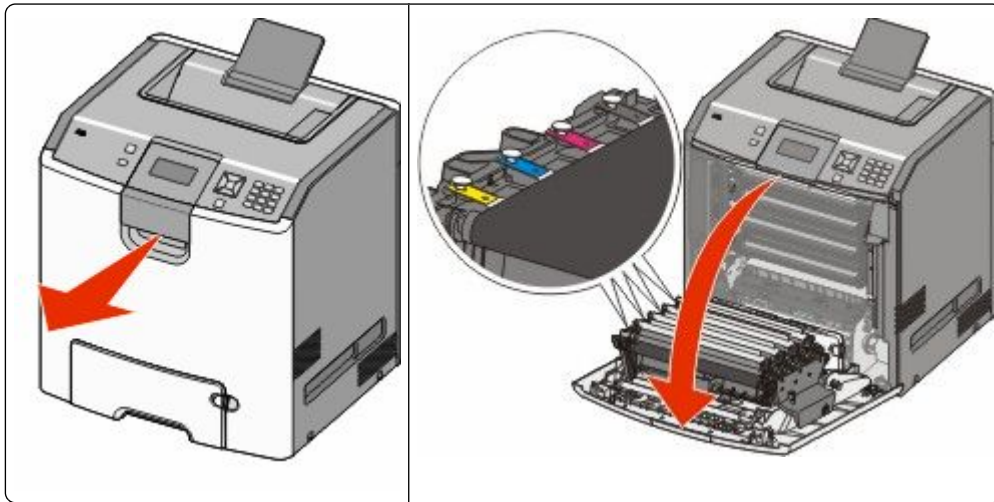

Warning—Potential Damage: To avoid overexposing the photoconductors, do not leave the door open for more than 10 minutes.

- 2 Pull the specified photoconductor up, and then slide it to the right to remove it from the printer.

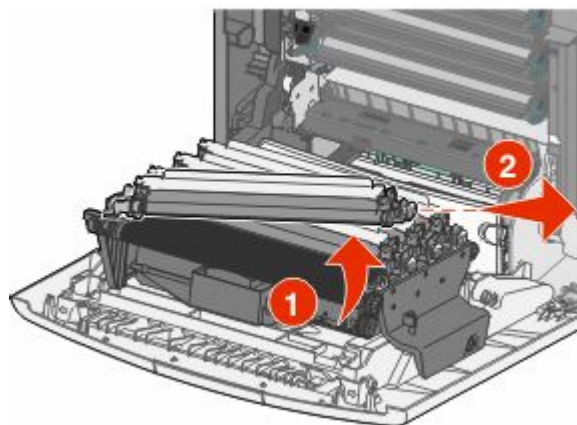

3 Unpack the replacement photoconductor.

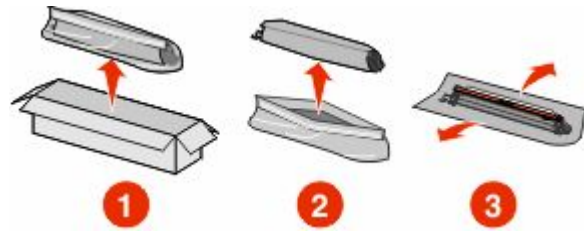

4 Align and insert the left end of the photoconductor, and then *snap* the right end into place.

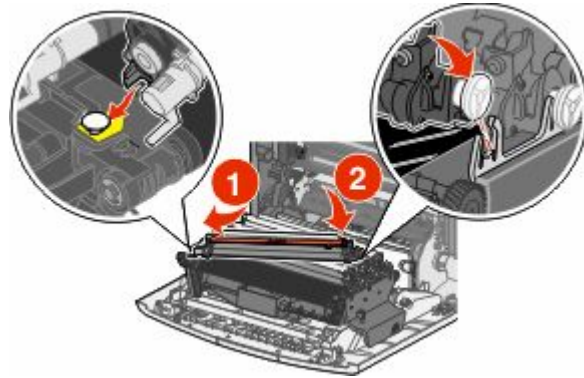

5 Remove the red packing strip from the top of the photoconductor.

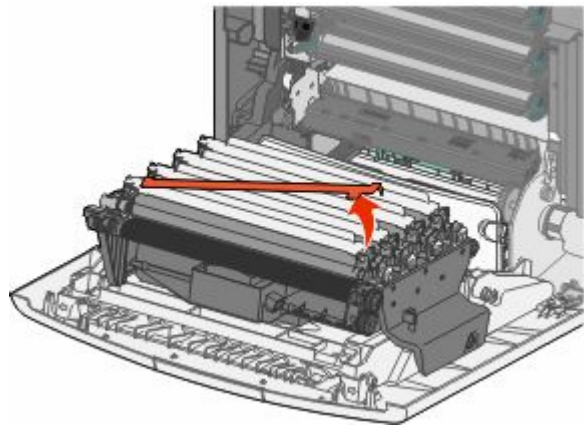

- 6 Place the old photoconductor into the replacement photoconductor box, and then place the return label on the box for shipping to Lexmark for recycling.

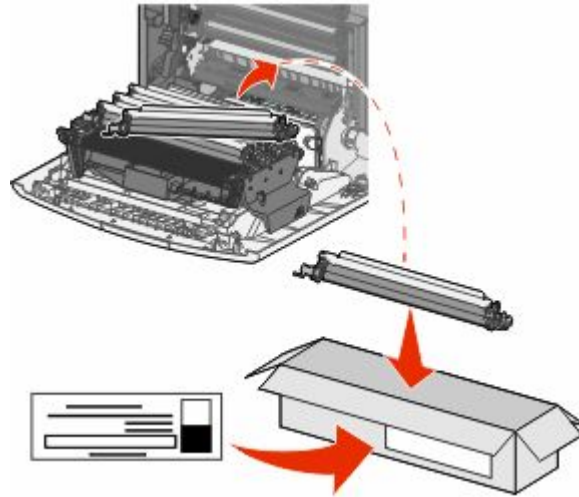

- 7 Close the front door.

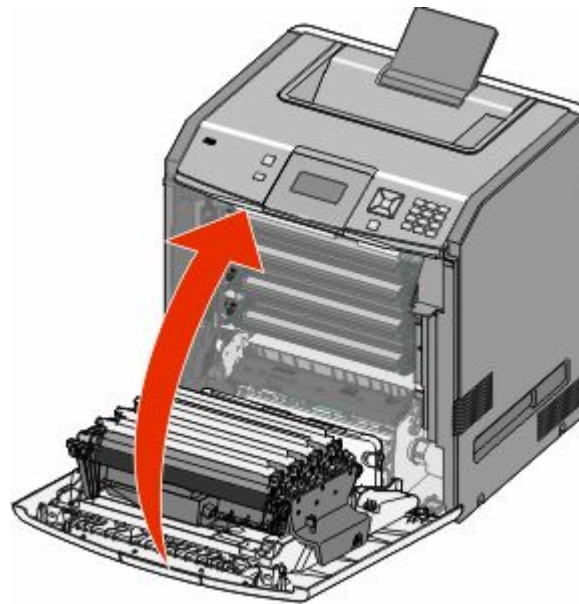

- 8 If you see **84 Replace <color> photoconductor**, **84 <color> photoconductor nearly low**, or **84 <color> photoconductor low** on the printer control panel, press the down arrow button until **✓ Supply Replaced** appears, and then press **✓**.

Note: Failure to reset the life count may result in degraded print quality.







Replaced <color> photoconductor appears.

✓Yes appears.

- 9 Press **✓** to clear the message.

If you are prompted to replace only one photoconductor, then the **Ready** screen will appear, and the task is complete. If you are prompted to replace additional photoconductors, repeat Steps 8 and 9 for each additional photoconductor. After all photoconductors have been replaced, **Ready** appears, and the task is complete.

If you see **Ready** on the printer display screen after you have replaced a photoconductor, follow Steps 1 through 7 below.

- 1 To specify the replaced photoconductor, press .
✓ **Supplies Menu** appears.
- 2 Press .
✓ **Replace Supply** appears.
- 3 Press .
- 4 Press the down arrow button until ✓ **All**, ✓ **Cyan photoconductor**, ✓ **Magenta photoconductor**, ✓ **Yellow photoconductor**, or ✓ **Black photoconductor** appears, depending on the photoconductor you just replaced.
- 5 Press .
<color> **photoconductor replaced** appears.
✓ **Yes** appears.
- 6 Press .
- 7 Press  until **Ready** appears.
The task is complete.

Replacing a toner cartridge

When **88 Replace <color> cartridge**, **88 <color> cartridge nearly low**, or **88 <color> cartridge low** appears on the printer control panel, or when print becomes faded, try to extend the life of the specified cartridge.

- 1 Open the front door.

Warning—Potential Damage: Make sure the printer is not open for 10 minutes or more to avoid overexposing the photoconductor units to light.

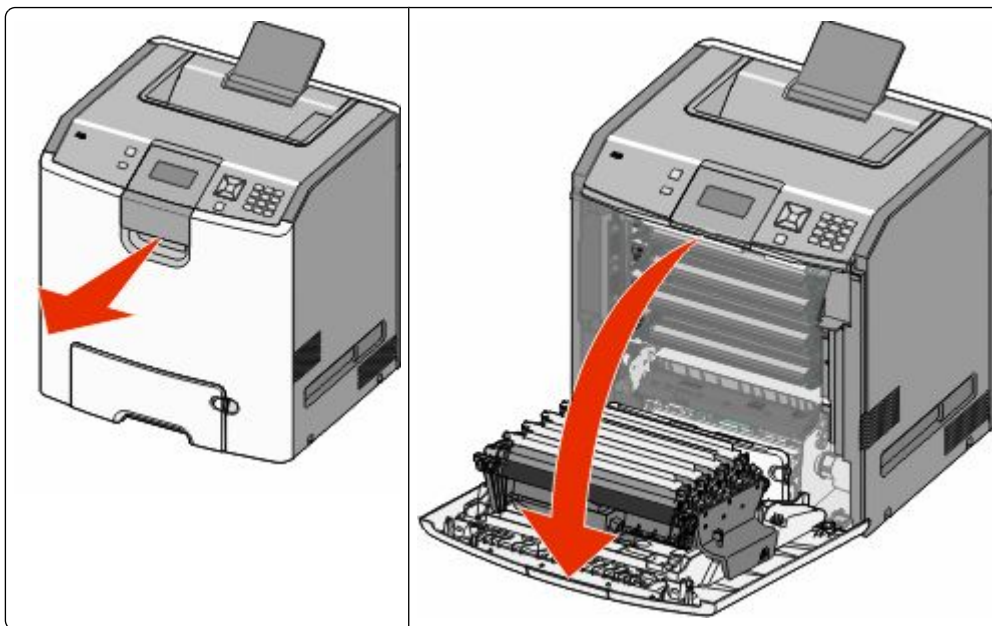

2 Pull up and out on the green tabs of the specified cartridge to remove it from the printer.

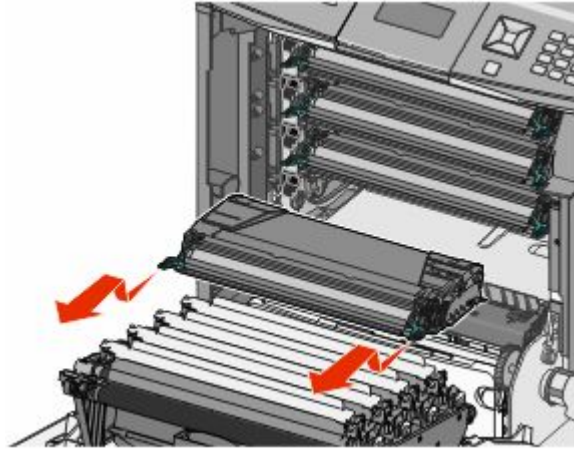

3 Shake the cartridge front to back and side to side to redistribute the toner.



4 Reinsert the cartridge to continue printing.

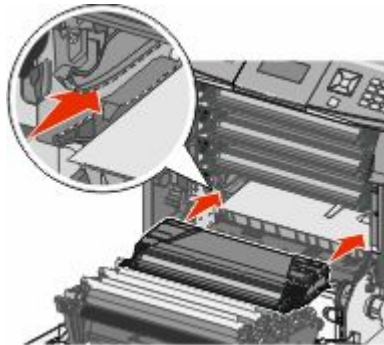

5 Repeat this process multiple times until printed text and graphics remain faded.

When printed text and graphics remain faded, replace the specified cartridge. Repeat steps 1 and 2, and then follow the steps below.

6 Unpack a new cartridge.

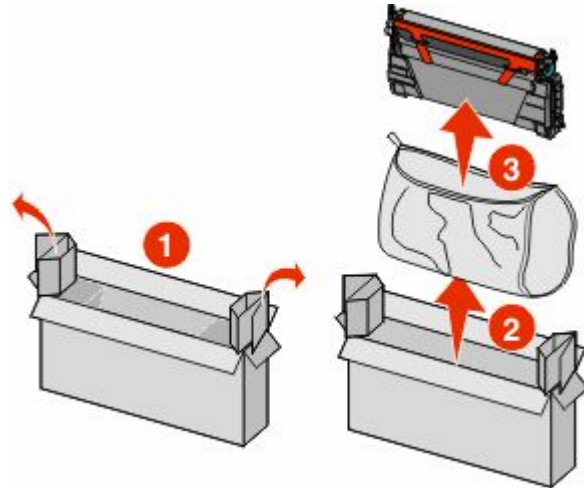

7 Place the old cartridge in the replacement cartridge shipping box, and then attach the return label to the box for shipping.

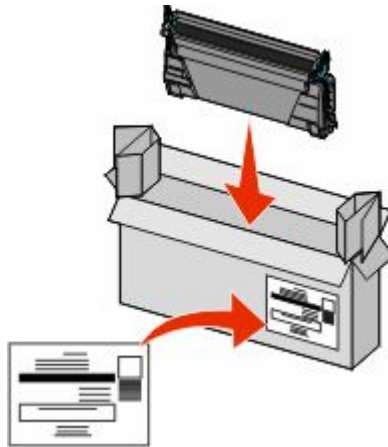

8 Shake the new cartridge front to back and side to side to evenly distribute the toner.



9 Remove the red packing strips from the new cartridge.

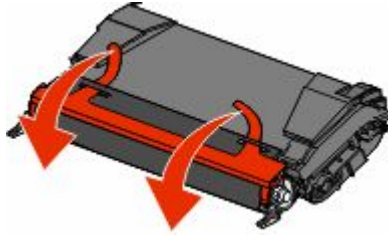

10 Insert the new cartridge into the printer.

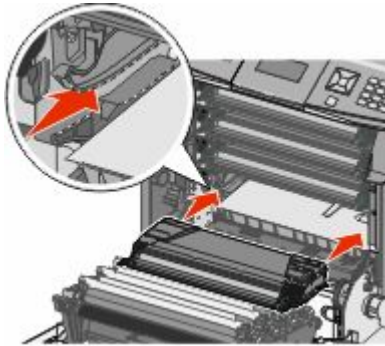

11 Close the front door.

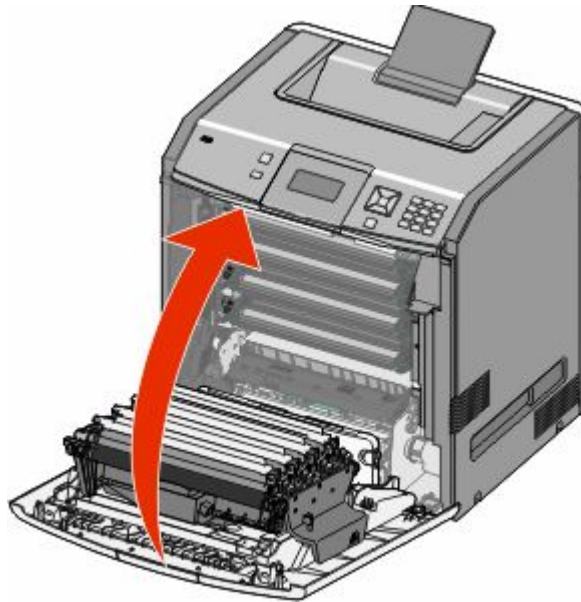

Note: Make sure each cartridge is fully pushed in. If a cartridge is not installed correctly, the printer may issue a **<color> Cartridge Missing** message, where **<color>** is **Black, Cyan, Magenta, or Yellow**. The printer may also issue the message **Close front door**.

If either of these messages appears, follow the steps below to clear the printer control panel message and continue printing.

- 1** Open the front door.
- 2** Remove the specified cartridge.

- 3 Reinstall the specified cartridge.
- 4 Close the front door.
- 5 Check the printer control panel to see if it is clear of messages.
- 6 Repeat as needed for additional toner cartridge replacement.

Replacing the waste toner box

Replace the waste toner box when **82 Replace waste toner box** or **82 Waste toner box nearly full** appears. The printer will not continue printing until the waste toner box is replaced.

- 1 Unpack the replacement waste toner box, and remove it from its shipping box.

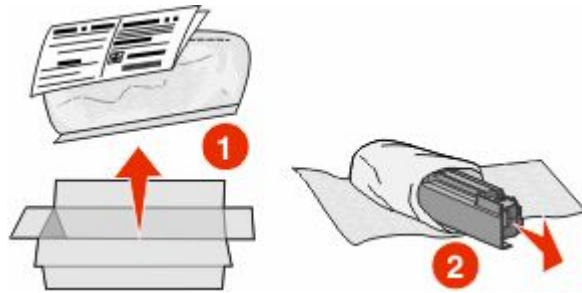

- 2 Locate the waste toner box release button on the left side of the printer.
- 3 Press the release button to the left, and pull the waste toner box out to remove it from the printer.

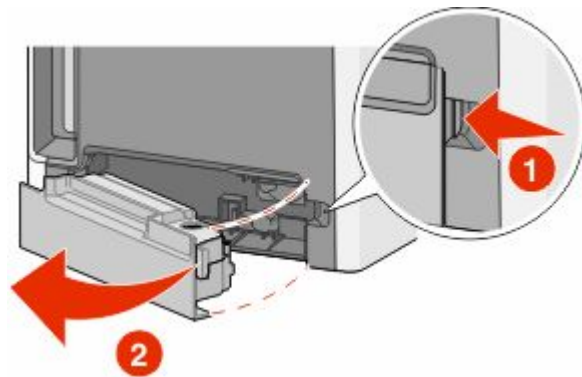

- 4 Peel the seal from the side of the full waste toner box as shown, and then place it over the hole to seal off the waste toner box.

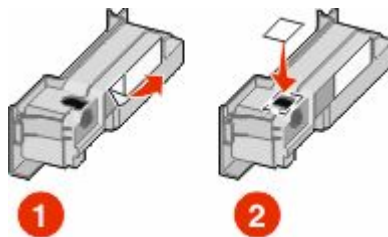

- 5 Place the sealed waste toner box in the recycling bag.

6 Place the bag into the shipping box you just removed the replacement part from.

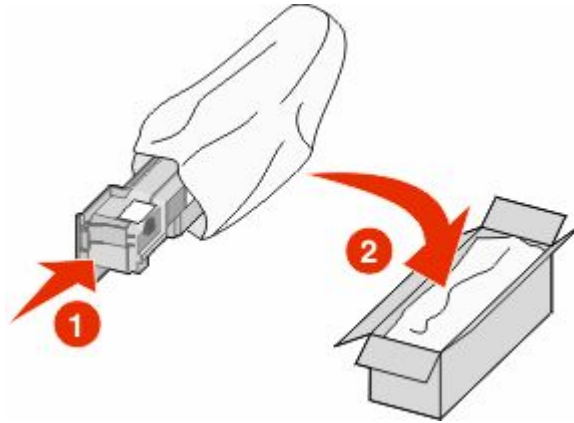

7 Peel the recycling label off, and place it on the shipping box.

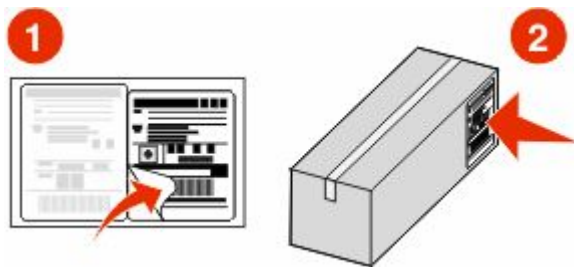

8 Insert the new waste toner box into the printer.

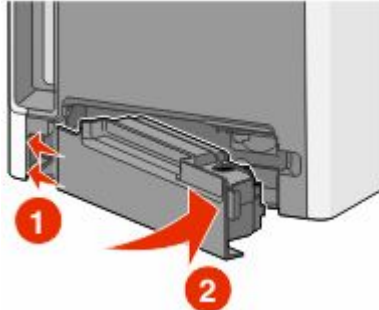

Moving the printer

Before moving the printer

⚠ CAUTION—POTENTIAL INJURY: The printer weight is greater than 18 kg (40 lb) and requires two or more trained personnel to lift it safely.



Follow these guidelines to avoid personal injury or printer damage:

- Always use at least two people to lift the printer.
- Always turn off the printer using the power switch before moving it.
- Disconnect all cords and cables from the printer before moving it.
- Remove the printer from the options before moving it.

Warning—Potential Damage: Damage to the printer caused by improper moving is not covered by the printer warranty.

Moving the printer to another location

The printer and options can be safely moved to another location by following these precautions:

- Remove the printer from the options before moving it.
- Any cart used to move the printer must have a surface able to support the full footprint of the printer. Any cart used to move the options must have a surface able to support the dimensions of the options.
- Keep the printer in an upright position.
- Avoid severe jarring movements.

Setting the printer up in a new location

When the printer is set up, allow clearance around it as shown.

	1	152.4 mm (6.0 in.)
	2	101.6 mm (4.0 in.)
	3	609.6 mm (24.0 in.)
	4	101.6 mm (4.0 in.)
	5	304.8 mm (12.0 in.)

Shipping the printer

When shipping the printer, use the original packaging or call the place of purchase for a relocation kit.

Administrative support

Finding advanced networking and administrator information

This chapter covers basic administrative support tasks. For more advanced system support tasks, see the *Networking Guide* on the *Software and Documentation* CD and the *Embedded Web Server Administrator's Guide* on the Lexmark Web site at www.lexmark.com.

Using the Embedded Web Server

If the printer is installed on a network, the Embedded Web Server is available for a range of functions including:

- Viewing a virtual display of the printer control panel
- Checking the status of the printer supplies
- Configuring printer settings
- Configuring network settings
- Viewing reports

To access the Embedded Web Server, type the printer IP address into the address field of your Web browser.

Notes:

- If you do not know the IP address of the printer, then print a network setup page and locate the IP address in the TCP/IP section.
- For more information, see the *Networking Guide* on the *Software and Documentation* CD and the *Embedded Web Server Administrator's Guide* on the Lexmark Web site at www.lexmark.com.

Checking the virtual display

When the Embedded Web Server is open, a virtual display appears in the top left corner of the screen. It works as an actual display would work on a printer control panel, showing printer messages.

To access the Embedded Web Server, type the printer IP address into the address field of your Web browser.

Note: If you do not know the IP address of the printer, then print a network setup page and locate the IP address in the TCP/IP section.

The virtual display appears in the top left corner of the screen.

Checking the device status

Using the Embedded Web Server, you can view paper tray settings, the level of toner in the print cartridge, the percentage of life remaining in the maintenance kit, and capacity measurements of certain printer parts. To view the device status:

- 1 Type the printer IP address in the address field of your Web browser.

Note: If you do not know the IP address of the printer, then print a network setup page and locate the IP address in the TCP/IP section.

- 2 Click **Device Status**.

Setting up e-mail alerts

You can have the printer send you an e-mail when the supplies are getting low or when the paper needs to be changed, added, or unjammed.

To set up e-mail alerts:

- 1 Type the printer IP address into the address field of your Web browser.

Note: If you do not know the IP address of the printer, then print a network setup page and locate the IP address in the TCP/IP section.

- 2 Click **Settings**.

- 3 Under Other Settings, click **E-mail Alert Setup**.

- 4 Select the items for notification, and type in the e-mail addresses.

- 5 Click **Submit**.

Note: See your system support person to set up the e-mail server.

Viewing reports

You can view some reports from the Embedded Web Server. These reports are useful for assessing the status of the printer, the network, and supplies.

To view reports from a network printer:

- 1 Type the printer IP address into the address field of your Web browser.









Note: If you do not know the IP address of the printer, then print a network setup page and locate the IP address in the TCP/IP section.

- 2 Click **Reports**, and then click the type of report you want to view.

Restoring the factory default settings

If you want to retain a list of the current menu settings for reference, then print a menu settings page before you restore the factory default settings. For more information, see “Printing a menu settings page” on page 37.

Warning—Potential Damage: Restoring factory defaults returns most printer settings to the original factory default setting. Exceptions include the display language, custom sizes and messages, and Network/Port menu settings. All downloads stored in RAM are deleted. Downloads stored in flash memory or on a printer hard disk are not affected.

- 1 From the printer control panel, press .
 - 2 Press the down arrow button until  **Settings** appears, and then press .
 - 3 Press the down arrow button until  **General Settings** appears, and then press .
 - 4 Press the down arrow button until  **Factory Defaults** appears, and then press .
 - 5 Press the down arrow button until  **Restore Now** appears, and then press .
- Restoring Factory Defaults** appears.

Troubleshooting

Checking an unresponsive printer

If your printer is not responding, make sure:

- The power cord is plugged into the printer and a properly grounded electrical outlet.
- The electrical outlet is not turned off by any switch or breaker.
- The printer is not plugged into any surge protectors, uninterrupted power supplies, or extension cords.
- Other electrical equipment plugged into the outlet is working.
- The printer is turned on.
- The printer cable is securely attached to the printer and the host computer, print server, option, or other network device.

Once you have checked each of these possibilities, turn the printer off and then back on. This often fixes the problem.

Solving printing problems

Multiple-language PDFs do not print

The documents contain unavailable fonts.

- 1 Open the document you want to print in Adobe Acrobat.
- 2 Click the printer icon.
The Print dialog appears.
- 3 Select **Print as image**.
- 4 Click **OK**.

Printer control panel display is blank or displays only diamonds

The printer self test failed. Turn the printer off, wait about 10 seconds, and then turn the printer back on.

If **Performing Self Test** and **Ready** do not appear, turn the printer off and contact Customer Support.

Error message about reading USB drive appears

Make sure the USB drive is supported. For information regarding tested and approved USB flash memory devices, visit the Lexmark Web site at www.lexmark.com.

Jobs do not print

These are possible solutions. Try one or more of the following:

MAKE SURE THE PRINTER IS READY TO PRINT

Make sure **Ready** or **Power Saver** appears on the display before sending a job to print.

CHECK TO SEE IF THE STANDARD EXIT BIN IS FULL

Remove the stack of paper from the standard exit bin.

CHECK TO SEE IF THE PAPER TRAY IS EMPTY

Load paper in the tray.

MAKE SURE THE CORRECT PRINTER SOFTWARE IS INSTALLED

- Verify that you are using the correct printer software.
- If you are using a USB port, make sure you are running a supported operating system and using compatible printer software.

MAKE SURE THE INTERNAL PRINT SERVER IS INSTALLED PROPERLY AND WORKING

- Make sure the internal print server is properly installed and that the printer is connected to the network. For more information about installing a network printer, click **View User's Guide and Documentation** on the *Software and Documentation CD*.
- Print a network setup page and check that the status shows **Connected**. If the status is **Not Connected**, check the network cables, and then try printing the network setup page again. Contact your system support person to make sure the network is functioning correctly.

Copies of the printer software are also available on the Lexmark Web site at www.lexmark.com.

MAKE SURE YOU ARE USING A RECOMMENDED PRINTER CABLE

For more information, visit the Lexmark Web site at www.lexmark.com.

MAKE SURE PRINTER CABLES ARE SECURELY CONNECTED

Check the cable connections to the printer and print server to make sure they are secure.

For more information, see the setup documentation that came with the printer.

Confidential and other held jobs do not print

These are possible solutions. Try one or more of the following:

PARTIAL JOB, NO JOB, OR BLANK PAGE PRINTS

The print job may contain a formatting error or invalid data.

- Delete the print job, and then print it again.
- For PDF documents, recreate the PDF and then print it again.

If you are printing from the Internet, then the printer may be reading multiple job titles as duplicates and deleting all jobs except the first one.

- For Windows users, open Print Properties. From the Print and Hold dialog, select the "Keep duplicate documents" check box under the User name text box before entering a PIN number.
- For Macintosh users, save each print job, naming each job differently, and then send the individual jobs to the printer.

MAKE SURE THE PRINTER HAS SUFFICIENT MEMORY

Free up additional printer memory by scrolling through the list of held jobs and deleting some of them.











Job takes longer than expected to print

These are possible solutions. Try one or more of the following:

REDUCE THE COMPLEXITY OF THE PRINT JOB

Reduce the number and size of fonts, the number and complexity of images, and the number of pages in the job.

CHANGE THE PAGE PROTECT SETTING TO OFF

- 1 From the printer control panel, press .
- 2 Press the down arrow button until  **Settings** appears, and then press .
- 3 Press the down arrow button until  **General Settings** appears, and then press .
- 4 Press the down arrow button until  **Print Recovery** appears, and then press .
- 5 Press the down arrow button until  **Page Protect** appears, and then press .
- 6 Press the down arrow button until  **OFF** appears, and then press .

CHANGE ENVIRONMENTAL SETTINGS

When using Eco-Mode or Quiet Mode settings, you may notice a reduction in performance. If you want to change the settings and need more information, then see “Using Eco-Mode” on page 51 or “Reducing printer noise” on page 52.

Job prints from the wrong tray or on the wrong paper

CHECK THE PAPER TYPE SETTING

Make sure the Paper Type setting matches the paper loaded in the tray.

Incorrect characters print

Make sure the printer is not in Hex Trace mode. If **Ready Hex** appears on the display, you must exit Hex Trace mode before you can print your job. Turn the printer off and back on to exit Hex Trace mode.

Tray linking does not work

ARE THE SAME SIZE AND TYPE OF PAPER LOADED IN EACH TRAY?

- Load the same size and type of paper in each tray.
- Move the paper guides to the correct positions for the paper size loaded in each tray.

ARE THE PAPER SIZE AND PAPER TYPE SETTINGS THE SAME FOR EACH TRAY?

- Print a menu settings page, and compare the settings for each tray.
- If necessary, adjust the settings from the Paper Size/Type menu.

Note: The multipurpose tray does not automatically sense the paper size. You must set the size from the Paper Size/Type menu.

Large jobs do not collate

These are possible solutions. Try one or more of the following:

MAKE SURE COLLATE IS SET TO ON

From the Finishing menu or Print Properties, set Collate to On.

Note: Setting Collate to Off in the software overrides the setting in the Finishing menu.

REDUCE THE COMPLEXITY OF THE PRINT JOB











Reduce the complexity of the print job by eliminating the number and size of fonts, the number and complexity of images, and the number of pages in the job.

MAKE SURE THE PRINTER HAS ENOUGH MEMORY

Add printer memory or an optional hard disk.

Unexpected page breaks occur

Increase the Print Timeout value:

- 1 From the printer control panel, press .
- 2 Press the down arrow button until  **Settings** appears, and then press .
- 3 Press the down arrow button until  **General Settings** appears, and then press .
- 4 Press the down arrow button until  **Timeouts** appears, and then press .
- 5 Press the down arrow button until  **Print Timeout** appears, and then press .
- 6 Press the right arrow button until the desired value appears, and then press .

Solving option problems

Option does not operate correctly or quits after it is installed

These are possible solutions. Try one or more of the following:

RESET THE PRINTER

Turn the printer off, wait for about 10 seconds, and then turn the printer on.

CHECK TO SEE IF THE OPTION IS CONNECTED TO THE PRINTER

- 1** Turn the printer off.
- 2** Unplug the printer.
- 3** Check the connection between the option and the printer.

MAKE SURE THE OPTION IS INSTALLED

Print a menu settings page and check to see if the option is listed in the Installed Options list. If the option is not listed, reinstall it.

MAKE SURE THE OPTION IS AVAILABLE IN THE PRINTER DRIVER

It may be necessary to manually add the option in the printer driver to make it available for print jobs. For more information, see "Updating available options in the printer driver" on page 38.

MAKE SURE THE OPTION IS SELECTED

From the program you are using, select the option. Mac OS 9 users should make sure the printer is set up in the Chooser.

Trays / Drawers

MAKE SURE THE PAPER IS LOADED CORRECTLY

- 1** Open the paper tray.
- 2** Check for paper jams or misfeeds.
- 3** Make sure the paper tray closes properly.

RESET THE PRINTER

Turn the printer off. Wait 10 seconds. Turn the printer back on.

Flash memory card

Make sure the flash memory card is securely connected to the printer system board.

Hard disk with adapter

Make sure the hard disk is securely connected to the printer system board.

Internal Solutions Port

If the Lexmark Internal Solutions Port (ISP) does not operate correctly, then these are possible solutions. Try one or more of the following:

CHECK THE ISP CONNECTIONS

- Make sure the ISP is securely attached to the printer system board.
- Make sure the cable is securely connected to the correct connector.

CHECK THE CABLE

Make sure you are using the correct cable and that it is securely connected.

MAKE SURE THE NETWORK SOFTWARE IS CONFIGURED CORRECTLY

For information about installing software for network printing, see the *Networking Guide* on the *Software and Documentation CD*

Internal print server

If the internal print server does not operate correctly, these are possible solutions. Try one or more of the following:

CHECK THE PRINT SERVER CONNECTIONS

- Make sure the internal print server is attached securely to the printer system board.
- Make sure you are using the correct (optional) cable and that it is securely connected.

MAKE SURE THE NETWORK SOFTWARE IS CONFIGURED CORRECTLY

For information about installing software for network printing, click **Additional** on the *Software and Documentation CD*, and then select the **Networking Guide** link under **Publications on this CD**.

Memory card

Make sure the memory card is securely connected to the printer system board.

USB/parallel interface card

Check the USB/parallel interface card connections:

- Make sure the USB/parallel interface card is securely connected to the printer system board.
- Make sure you are using the correct cable and that it is securely connected.

Solving paper feed problems

Paper frequently jams

These are possible solutions. Try one or more of the following:

CHECK THE PAPER

Use recommended paper and other specialty media. For more information, see the chapter about paper and specialty media guidelines.

MAKE SURE THERE IS NOT TOO MUCH PAPER IN THE PAPER TRAY

Make sure the stack of paper you load does not exceed the maximum stack height indicated in the tray or on the multipurpose feeder.

CHECK THE PAPER GUIDES

Move the guides in the tray to the correct positions for the paper size loaded.

HAS THE PAPER ABSORBED MOISTURE DUE TO HIGH HUMIDITY?













- Load paper from a fresh package.
- Store paper in its original wrapper until you use it.

Paper jam message remains after jam is cleared

The paper path is not clear. Clear jammed paper from the entire paper path, and then press .

Page that jammed does not reprint after you clear the jam

In the Setup menu, Jam Recovery is set to Off. Set Jam Recovery to Auto or On:

- 1 Press .
- 2 Press the down arrow button until  **Settings** appears, and then press .
- 3 Press the down arrow button until  **General Settings** appears, and then press .
- 4 Press the down arrow button until  **Print Recovery** appears, and then press .
- 5 Press the down arrow button until  **Jam Recovery** appears, and then press .
- 6 Press the down arrow button until  **On** or  **Auto** appears, and then press .

Solving print quality problems

The information in the following topics may help you solve print quality problems. If these suggestions do not correct the problem, contact Customer Support. You may have a printer part that requires adjustment or replacement.

Isolating print quality problems

To help isolate print quality problems, print the print quality test pages:

- 1 Make sure paper is loaded in Tray 1.
- 2 Turn the printer off.
- 3 From the printer control panel, press and hold and the right arrow button while turning the printer on.
- 4 Release both buttons when the clock appears, and wait for **Config Menu** to appear.
- 5 Press the down arrow button until **Prt Quality Pgs** appears, and then press .
The print quality test pages print.
- 6 Press the down arrow button until **Exit Config Menu** appears, and then press .
Resetting the Printer appears briefly, followed by a clock, and then **Ready** appears.

Blank pages

Cause	Solution
Packaging materials have not been removed from the toner cartridge.	Remove the packaging materials from the toner cartridge, and reinstall it.
Toner is low.	<ul style="list-style-type: none">• Remove the toner cartridge from the printer. Shake the cartridge back and forth several times, and then reinstall it.• Install a new toner cartridge.
Toner cartridge is defective or empty.	Replace the toner cartridge.
Printer requires servicing.	Call for service.

Characters have jagged or uneven edges







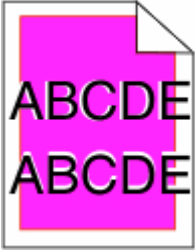





If you are using downloaded fonts, verify that the fonts are supported by the printer, the host computer, and the software program.

Color misregistration

Example	Cause	Solution
	Color has shifted outside of the appropriate area or has been superimposed over another color area.	<ol style="list-style-type: none"> 1 Recalibrate the printer. <ul style="list-style-type: none"> • Perform Color Adjust from the Quality menu 2 Remove and reinstall the photoconductor. 3 Adjust the color alignment. For more information, see "Adjusting the color alignment" on page 184. <p>Note: If you have not resolved the issue, then recalibrate again. If necessary, adjust the color alignment again.</p>

Adjusting the color alignment

- 1 Make sure that the printer is turned off.
- 2 From the printer control panel, press and hold  and the right arrow button while turning the printer on.
- 3 Release both buttons when the clock appears.
The printer performs its power-on sequence, and then **Config Menu** appears.
- 4 Press the down arrow button until  **Color Alignment** appears, and then press .
- 5 Press  again to print the alignment page.
- 6 Press the down arrow button until  **Set A** appears, and then press .
- 7 From the printed sheet, find the straightest of the 20 lines beside the letter A.
- 8 Press the left arrow button or the right arrow button until that number is displayed, and then press 
Submitting selection appears.
- 9 Repeat steps 6 through 8 to align sets A through L.
- 10 Press .
- 11 Press .
- 12 Press the down arrow button until  **Exit Config Menu** appears, and then press 
Resetting the Printer appears briefly, followed by a clock, and then **Ready** appears.

Clipped images

Cause	Solution
Guides in the selected tray are set for a different paper size than what is loaded in the tray.	Move the guides in the tray to the proper positions for the size loaded.
There could be an incorrect page size selected in the driver or program.	<ul style="list-style-type: none"> • Specify the correct page size in the driver or program. • Set the Paper Size to match the media in the tray.

Fine horizontal lines appear on color pages

You may notice fine, horizontal lines in photographs or pages with a high concentration of color. This can occur when the printer is in Quiet Mode. To fix this, set Quiet Mode to **Off (Image/Photo)**.

Ghost images

Cause	Solution
The photoconductor is not functioning properly.	<ul style="list-style-type: none"> Make sure the Paper Type setting is correct for the media that you are using. Replace the photoconductor.
The paper weight or Paper Weight setting in the Paper Menu is wrong for the type of paper being used.	Make sure the Paper Type and Paper Weight settings match the type of paper that you are using.
Toner is low.	Replace the toner cartridge.

Gray background

Cause	Solution
Toner darkness setting is too dark.	Select a different toner darkness setting in the printer software before sending the job to print.
Toner cartridge is worn or defective.	Replace the toner cartridge.

Incorrect margins

Cause	Solution
Guides in the selected tray are set for a different paper size than what is loaded in the tray.	Move the guides in the tray to the proper positions for the size loaded.
Auto size sensing is set to Off, but you loaded a different size paper in a tray. For example, you inserted A4-size paper into the selected tray but did not set the Paper Size to A4.	<ul style="list-style-type: none"> Set the Paper Size to match the paper size in the tray. Specify the correct page size in Print Properties or the program.

Light colored line, white line, or incorrectly colored line



Example	Cause	Solution
	Toner cartridge is defective.	Replace the color cartridge causing the line.
	Photoconductor is defective.	Replace the photoconductor.
	Transfer module is defective.	Replace the transfer module.

Example	Cause	Solution
	Printhead lenses are dirty.	Clean the printhead lenses.

Paper curls badly

Cause	Solution
Paper Type and Paper Weight settings are not appropriate for the type of paper or specialty media that you are using.	Change the Paper Type and Paper Weight settings to match the paper or specialty media loaded in the printer.
Paper has been stored in a high-humidity environment.	Load paper from a fresh package. Store paper in its original wrapper until you use it.

Print irregularities

Example	Cause	Solution
	Paper has absorbed moisture due to high humidity.	Load paper from a fresh package into the paper tray.
	You are using paper that does not meet the printer specifications.	Make sure that the Paper Type and Paper Weight settings match the type of paper that you are using. Avoid textured paper with rough finishes.
	A toner cartridge, the transfer module, or the fuser is worn or defective.	Replace the print cartridge, the transfer module, or the fuser.

Print is too dark

Cause	Solution
Printer may not have recalibrated recently.	Perform Color Adjust from the Quality menu.
Toner Darkness setting is too dark, RGB Brightness setting is too dark, or RGB Contrast setting is too high.	Select a different Toner Darkness setting, RGB Brightness setting, or RGB Contrast setting from Print Properties before sending the job to print.
Toner cartridge is worn or defective.	Replace the toner cartridge.

Print is too light

Cause	Solution
Printer may not have recalibrated recently.	Perform Color Adjust from the Quality menu.
Toner Darkness setting is too light, RGB Brightness setting is too bright, or RGB Contrast setting is too high.	<ul style="list-style-type: none"> Select a different Toner Darkness setting, RGB Brightness setting, or RGB Contrast setting from Print Properties before sending the job to print. Adjust the color quality settings in the Quality menu.
You are using paper that does not meet the printer specifications.	<ul style="list-style-type: none"> Load paper from a new package. Avoid textured paper with rough finishes. Make sure the paper you load in the trays is not damp. Make sure the Paper Type and Paper Weight settings match the type of paper that you are using.
Color Saver is On.	Turn Color Saver off in the Quality menu.
Toner is low.	Replace the toner cartridge.
Toner cartridge is worn or defective.	

Repeating defects

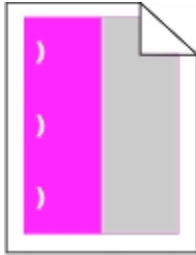
Cause	Solution
	
If marks occur repeatedly in only one color and multiple times on a page:	
A toner cartridge is defective.	Replace the toner cartridge if the defects occur every: <ul style="list-style-type: none"> 33.0 mm (1.30 in.) 35.3 mm (1.39 in.)
A photoconductor is defective.	Replace the photoconductor if the defects occur every: <ul style="list-style-type: none"> 28.3 mm (1.11 in.) 72.4 mm (2.85 in.)
If marks occur down the page repeatedly in all colors:	
The fuser is defective.	Replace the fuser if the defects occur every: <ul style="list-style-type: none"> 47.4 mm (1.87 in.) 94.8 mm (3.73 in.) 113.0 mm (4.45 in.)

Skewed print

Cause	Solution
Guides in the selected tray are not in the correct position for the paper size loaded in the tray.	<p>Move the guides in the tray to the proper positions for the size loaded.</p> <ul style="list-style-type: none"> • Make sure that the width guide is not too far from the paper stack. • Make sure that the width guide is not pressing too tightly against the paper stack. • Make sure that the length guide is not too far from the paper stack. • Make sure that the length guide is not pressing too tightly against the paper stack.
You are using paper that does not meet the printer specifications.	Make sure that you are using paper that meets the printer specifications.

Solid color pages

Cause	Solution
Photoconductor is installed incorrectly.	Remove and then reinstall the photoconductor.
Photoconductor is defective.	Replace the photoconductor.
Printer requires servicing.	Call for service.

Streaked horizontal lines

Example	Cause	Solution
	A toner cartridge is defective, empty, or worn.	Replace the toner cartridge.
	Fuser is defective or worn.	Replace the fuser.
	Photoconductor may be defective.	Replace the defective photoconductor.

Streaked vertical lines

Example	Cause	Solution
	Toner is smeared before fusing to the paper.	If paper is stiff, try feeding from another tray.
	Toner cartridge is defective.	Replace the toner cartridge causing the streaks.
	Transfer module is worn or defective.	Replace the transfer module.

Toner fog or background shading appears on the page

Cause	Solution
Toner cartridge is defective or installed incorrectly.	Reinstall or replace the cartridge.
Transfer module is worn or defective.	Replace the transfer module.
Photoconductor is worn or defective.	Replace the photoconductor.
Fuser is worn or defective.	Replace the fuser.
Toner is in the paper path.	Call for service.
Printer may not have recalibrated recently.	Perform color adjust from the Quality menu.
Application may specify off-white background.	Check the application.

Toner rubs off

Cause	Solution
Specialty media is being used.	Make sure the correct Paper Type is selected.
The Paper Weight setting in the Paper Menu is wrong for the type of paper being used.	Change the Paper Weight from Normal to Heavy. If necessary, change Paper Texture from Normal to Rough.
Fuser is worn or defective.	Replace the fuser.

Toner specks

Cause	Solution
Toner cartridges are worn or defective.	Replace the defective or worn cartridges.
Toner is in the paper path.	Call for service.
The photoconductor may be defective.	Replace the defective photoconductor.

Transparency print quality is poor

Cause	Solution
You are using transparencies that do not meet the printer specifications.	Use only transparencies recommended by the printer manufacturer.
Paper Type setting for the tray you are using is set to something other than Transparency.	Make sure the Paper Type setting is set to Transparency.

Uneven print density

Example	Cause	Solution
	Toner cartridge is worn or defective.	Replace the toner cartridge.
	Photoconductor is worn or defective.	Replace the photoconductor.

Solving color quality problems

This section helps answer some basic color-related questions and describes how some of the features provided in the Quality Menu can be used to solve typical color problems.

FAQ about color printing

What is RGB color?

Red, green, and blue light can be added together in various amounts to produce a large range of colors observed in nature. For example, red and green can be combined to create yellow. Televisions and computer monitors create colors in this manner. RGB color is a method of describing colors by indicating the amount of red, green, or blue needed to produce a certain color.

What is CMYK color?

Cyan, magenta, yellow, and black (known as *CMYK color*) inks or toners can be printed in various amounts to produce a large range of colors observed in nature. For example, cyan and yellow can be combined to create green. Printing presses, inkjet printers, and color laser printers create colors in this manner. CMYK color is a method of describing colors by indicating the amount of cyan, magenta, yellow, and black needed to reproduce a particular color.

How is color specified in a document to be printed?

Software applications typically specify document color using RGB or CMYK color combinations. Additionally, they commonly let you modify the color of each object in a document. For more information, see the software application Help section.

How does the printer know what color to print?

When you print a document, information describing the type and color of each object is sent to the printer. The color information is passed through color conversion tables that translate the color into the appropriate amounts of cyan, magenta, yellow, and black toner needed to produce the desired color. The object type information lets different color conversion tables be used for different types of objects. For example, it is possible to apply one type of color conversion table to text while applying a different color conversion table to photographic images.

Should I use PostScript or PCL emulation printer software? What settings should I use for the best color?

The PostScript driver is strongly recommended for best color quality. The default settings in the PostScript driver provide preferred color quality for the majority of printouts.

Why doesn't the printed color match the color that I see on the computer screen?

The color conversion tables used in Auto Color Correction mode generally approximate the colors of a standard computer monitor. However, because of technology differences that exist between printers and monitors, there are many colors that can also be affected by monitor variations and lighting conditions. For recommendations on how the printer color sample pages may be useful in solving certain color-matching problems, see the question, "How can I match a particular color (such as a color in a corporate logo)?"

The printed page appears tinted. Can I slightly adjust the color?

Sometimes you may consider printed pages to appear tinted (for example, everything printed seems to be too red). This can be caused by environmental conditions, paper type, lighting conditions, or user preference. In these instances, adjusting the Color Balance setting may create more preferable color. Color Balance lets you make subtle adjustments to the amount of toner being used in each color plane. Selecting positive (or negative) values for cyan, magenta, yellow, and black under the Color Balance menu will slightly increase (or decrease) the amount of toner used for the chosen color. For example, if you believe the overall printed page to be too red, then decreasing both magenta and yellow could potentially improve color.

My color transparencies seem dark when being projected. Is there anything I can do to improve the color?

This problem most commonly occurs when projecting transparencies with reflective overhead projectors. To obtain the highest projected color quality, transmissive overhead projectors are recommended. If a reflective projector must be used, then adjusting the Toner Darkness setting to 1, 2, or 3 will lighten the transparency.

Make sure to print on the recommended type of color transparencies. For more information about the paper and media specifications, see the *User's Guide* on the *Software and Documentation CD*.

What is manual color correction?

The color conversion tables applied to each object when using the default Auto Color Correction setting generate preferred color for the majority of documents. Occasionally, you may want to apply a different color table mapping. This customization is accomplished using the Manual Color menu and the Manual Color Correction setting.

Manual Color Correction applies to RGB and CMYK color conversion table mappings as defined in the Manual Color menu.

You can select any of the different color conversion tables for RGB or CMYK:

Color conversion table	Settings
RGB	<ul style="list-style-type: none">• sRGB Display• Display-True Black• sRGB Vivid• Vivid• Off
CMYK	<ul style="list-style-type: none">• US CMYK• Euro CMYK• Vivid CMYK• Off

Note: The Manual Color Correction setting is not useful if the software application does not specify colors with RGB or CMYK combinations. It is also not effective in situations where the software application or the computer operating system controls the adjustment of colors.

How can I match a particular color (such as a corporate logo)?

Occasionally, you may have a need for the printed color of a particular object to closely match a specific color. For example, you may need to match the color of a corporate logo. While instances can occur in which the printer cannot exactly reproduce the desired color, you should be able to identify adequate color matches for the majority of cases.

The Color Samples menu item can provide useful information in helping solve this particular type of color-matching problem. The nine Color Samples values correspond to color conversion tables in the printer. Selecting any of the Color Samples values generates a multiple-page printout consisting of hundreds of colored boxes. Either a CMYK or RGB combination is located on each box, depending on the table selected. The observed color of each box is obtained by passing the CMYK or RGB combination labeled on the box through the selected color conversion table.

You can examine the color samples pages and identify the box whose color is the closest to the desired color. The color combination labeled on the box can then be used for modifying the color of the object in a software application. For instructions, see the software application Help. Manual Color Correction may be necessary to utilize the selected color conversion table for the particular object.

Selecting which Color Samples pages to use for a particular color-matching problem depends on the Color Correction setting being used (Auto, Off, or Manual), the type of object being printed (text, graphics, or images), and how the color of the object is specified in the software application (RGB or CMYK combinations). When the printer Color Correction setting is set to Off, the color is based on the print job information; no color conversion is implemented.

Note: The Color Samples pages are not useful if the software application does not specify colors with RGB or CMYK combinations. Additionally, certain situations exist where the software application or the computer operating system adjusts the RGB or CMYK combinations specified in the application through color management. The resulting printed color may not be an exact match of the Color Samples pages.

The following table can help identify which Color Sample pages to use for color matching.

Color specification and object to be printed	Color Correction setting	Sample pages to use
RGB—Text	Auto	sRGB Vivid
	Manual	Manual Color RGB Text Setting
RGB—Graphic	Auto	sRGB Vivid
	Manual	Manual Color RGB Graphic Setting
RGB—Image	Auto	sRGB Display
	Manual	Manual Color RGB Image Setting
CMYK—Text	Auto	US CMYK or Euro CMYK
	Manual	Manual Color CMYK Text Setting
CMYK—Graphic	Auto	US CMYK
	Manual	Manual Color CMYK Graphic Setting
CMYK—Image	Auto	US CMYK
	Manual	Manual Color CMYK Image Setting

What are Detailed Color Samples and how do I access them?

These pages require the use of the Embedded Web Server. The Embedded Web Server is a series of resident pages stored in the network printer firmware. To access these pages, browse to the IP address of the network printer. Click **Configuration Menu**, and then click **Detailed Color Samples**.

For more information about using the Embedded Web Server, see the *User's Guide on the Software and Documentation CD*.

Detailed Color Samples are pages similar to the default pages of color samples accessible from the Quality menu using the printer control panel. The default color samples available using this method have an increment value of 10% for red, green, and blue. If you find a value on this page that is close, but would like to scan more colors in a nearby area, then you can use the Detailed Color Samples to select the desired color values and a more specific increment. This provides a way to print multiple pages of colored boxes that surround a specific color of interest.

There are nine conversion tables available with the following three options:

- **Print**—Prints the default pages
- **Detailed**—Lets you enter individual red, green, and blue values and a specific increment of color
- **Reset**—Lets you clear the existing information and enter new values

The process can be duplicated for Cyan (C), Magenta (M), Yellow (Y), and Black (K) color conversion tables, too. Collectively, these values are known as CMYK color. The default increment is 10% for Black and 20% each for Cyan, Magenta, and Yellow.

Embedded Web Server does not open

These are possible solutions. Try one or more of the following:

CHECK THE NETWORK CONNECTIONS

Make sure the printer and computer are turned on and connected to the same network.

CHECK THE NETWORK SETTINGS

Depending on the network settings, you may need to type `https://` instead of `http://` before the printer IP address to access the Embedded Web Server. For more information, see your system administrator.

Contacting Customer Support

When you call Customer Support, describe the problem you are experiencing, the message on the display, and the troubleshooting steps you have already taken to find a solution.

You need to know your printer model type and serial number. For more information, see the label on the inside top front cover of the printer. The serial number is also listed on the menu settings page.

In the U.S. or Canada, call (1-800-539-6275). For other countries/regions, visit the Lexmark Web site at www.lexmark.com.

Notices

Product information

Product name:

Lexmark C734n, C734dn, C734dtn, C734dw, C736n, C736dn, C736dtn

Machine type:

5026

Model(s):

210, 230, 280, 410, 430, 480

Machine type:

4976

n01, n02, n03, gn1, gn2, dn1, dn2, dn3, gd1, gd2, dw1, dw2, gw1, gw2

Machine type:

4977

n01, n02, n03, gn1, gn2, dn1, dn2, dn3, gd1, gd2

Edition notice

May 2009

The following paragraph does not apply to any country where such provisions are inconsistent with local law: LEXMARK INTERNATIONAL, INC., PROVIDES THIS PUBLICATION "AS IS" WITHOUT WARRANTY OF ANY KIND, EITHER EXPRESS OR IMPLIED, INCLUDING, BUT NOT LIMITED TO, THE IMPLIED WARRANTIES OF MERCHANTABILITY OR FITNESS FOR A PARTICULAR PURPOSE. Some states do not allow disclaimer of express or implied warranties in certain transactions; therefore, this statement may not apply to you.

This publication could include technical inaccuracies or typographical errors. Changes are periodically made to the information herein; these changes will be incorporated in later editions. Improvements or changes in the products or the programs described may be made at any time.

References in this publication to products, programs, or services do not imply that the manufacturer intends to make these available in all countries in which it operates. Any reference to a product, program, or service is not intended to state or imply that only that product, program, or service may be used. Any functionally equivalent product, program, or service that does not infringe any existing intellectual property right may be used instead. Evaluation and verification of operation in conjunction with other products, programs, or services, except those expressly designated by the manufacturer, are the user's responsibility.

For Lexmark technical support, visit support.lexmark.com.

For information on supplies and downloads, visit www.lexmark.com.

If you don't have access to the Internet, you can contact Lexmark by mail:

Lexmark International, Inc.
Bldg 004-2/CSC
740 New Circle Road NW
Lexington, KY 40550
USA

© 2009 Lexmark International, Inc.

All rights reserved.

UNITED STATES GOVERNMENT RIGHTS

This software and any accompanying documentation provided under this agreement are commercial computer software and documentation developed exclusively at private expense.

Trademarks

Lexmark, Lexmark with diamond design, MarkNet, and MarkVision are trademarks of Lexmark International, Inc., registered in the United States and/or other countries.

MarkTrack, PrintCryption, and StapleSmart are trademarks of Lexmark International, Inc.

PCL® is a registered trademark of the Hewlett-Packard Company. PCL is Hewlett-Packard Company's designation of a set of printer commands (language) and functions included in its printer products. This printer is intended to be compatible with the PCL language. This means the printer recognizes PCL commands used in various application programs, and that the printer emulates the functions corresponding to the commands.

The following terms are trademarks or registered trademarks of these companies:

Albertus	The Monotype Corporation plc
Antique Olive	Monsieur Marcel OLIVE
Apple-Chancery	Apple Computer, Inc.
Arial	The Monotype Corporation plc
CG Times	Based on Times New Roman under license from The Monotype Corporation plc, is a product of Agfa Corporation
Chicago	Apple Computer, Inc.
Clarendon	Linotype-Hell AG and/or its subsidiaries
Eurostile	Nebiolo
Geneva	Apple Computer, Inc.
GillsSans	The Monotype Corporation plc
Helvetica	Linotype-Hell AG and/or its subsidiaries
Hoefler	Jonathan Hoefler Type Foundry
ITC Avant Garde Gothic	International Typeface Corporation
ITC Bookman	International Typeface Corporation
ITC Mona Lisa	International Typeface Corporation

ITC Zapf Chancery	International Typeface Corporation
Joanna	The Monotype Corporation plc
Marigold	Arthur Baker
Monaco	Apple Computer, Inc.
New York	Apple Computer, Inc.
Oxford	Arthur Baker
Palatino	Linotype-Hell AG and/or its subsidiaries
Stempel Garamond	Linotype-Hell AG and/or its subsidiaries
Taffy	Agfa Corporation
Times New Roman	The Monotype Corporation plc
Univers	Linotype-Hell AG and/or its subsidiaries

All other trademarks are the property of their respective owners.

Federal Communications Commission (FCC) compliance information statement

This product has been tested and found to comply with the limits for a Class B digital device, pursuant to Part 15 of the FCC Rules. Operation is subject to the following two conditions: (1) this device may not cause harmful interference, and (2) this device must accept any interference received, including interference that may cause undesired operation

The FCC Class B limits are designed to provide reasonable protection against harmful interference when the equipment is operated in a residential installation. This equipment generates, uses, and can radiate radio frequency energy and, if not installed and used in accordance with the instructions, may cause harmful interference to radio communications. However, there is no guarantee that interference will not occur in a particular installation. If this equipment does cause harmful interference to radio or television reception, which can be determined by turning the equipment off and on, the user is encouraged to try to correct the interference by one or more of the following measures:

- Reorient or relocate the receiving antenna.
- Increase the separation between the equipment and receiver.
- Connect the equipment into an outlet on a circuit different from that to which the receiver is connected.
- Consult your point of purchase or service representative for additional suggestions.

The manufacturer is not responsible for radio or television interference caused by using other than recommended cables or by unauthorized changes or modifications to this equipment. Unauthorized changes or modifications could void the user's authority to operate this equipment.

Note: To assure compliance with FCC regulations on electromagnetic interference for a Class B computing device, use a properly shielded and grounded cable such as Lexmark part number 1021231 for parallel attach or 1021294 for USB attach. Use of a substitute cable not properly shielded and grounded may result in a violation of FCC regulations.

Any questions regarding this compliance information statement should be directed to:

Director of Lexmark Technology & Services
Lexmark International, Inc.
740 West New Circle Road
Lexington, KY 40550
(859) 232-3000

Noise emission levels

The following measurements were made in accordance with ISO 7779 and reported in conformance with ISO 9296.

Note: Some modes may not apply to your product.

1-meter average sound pressure, dBA	
Printing	55
Ready	33

Values are subject to change. See www.lexmark.com for current values.

Temperature information

Ambient temperature	15–32° C (60–90° F)
Shipping temperature	-40–60° C (-40–140° F)
Storage temperature	1–60° C (34–140° F)

Waste from Electrical and Electronic Equipment (WEEE) directive



The WEEE logo signifies specific recycling programs and procedures for electronic products in countries of the European Union. We encourage the recycling of our products. If you have further questions about recycling options, visit the Lexmark Web site at www.lexmark.com for your local sales office phone number.

Product disposal

Do not dispose of the printer or supplies in the same manner as normal household waste. Consult your local authorities for disposal and recycling options.

Battery notice

This product contains Perchlorate material. Special handling may apply. For more information, go to <http://www.dtsc.ca.gov/hazardouswaste/perchlorate/>.

ENERGY STAR



Laser notice

The printer is certified in the U.S. to conform to the requirements of DHHS 21 CFR Subchapter J for Class I (1) laser products, and elsewhere is certified as a Class I laser product conforming to the requirements of IEC 60825-1.

Class I laser products are not considered to be hazardous. The printer contains internally a Class IIIb (3b) laser that is a maximum 15 milliwatt gallium arsenide laser operating in the wavelength of 770-795 nanometers. The laser system and printer are designed so there is never any human access to laser radiation above a Class I level during normal operation, user maintenance, or prescribed service condition.

Power consumption

Product power consumption

The following table documents the power consumption characteristics of the product.

Note: Some modes may not apply to your product.

Mode	Description	Power consumption (Watts)
Printing	The product is generating hard-copy output from electronic inputs.	490, 530
Copying	The product is generating hard-copy output from hard-copy original documents.	N/A
Scanning	The product is scanning hard-copy documents.	N/A
Ready	The product is waiting for a print job.	45
Power Saver	The product is in energy-saving mode.	16
Off	The product is plugged into a wall outlet, but the power switch is turned off.	0

The power consumption levels listed in the previous table represent time-averaged measurements. Instantaneous power draws may be substantially higher than the average.

Values are subject to change. See www.lexmark.com for current values.

Power Saver

This product is designed with an energy-saving mode called Power Saver. The Power Saver Mode is equivalent to the EPA Sleep Mode. The Power Saver Mode saves energy by lowering power consumption during extended periods of inactivity. The Power Saver Mode is automatically engaged after this product is not used for a specified period of time, called the Power Saver Timeout.

Factory default Power Saver Timeout for this product (in minutes):

30

Off mode

If this product has an off mode which still consumes a small amount of power, then to completely stop product power consumption, disconnect the power supply cord from the wall outlet.

Total energy usage

It is sometimes helpful to calculate the total product energy usage. Since power consumption claims are provided in power units of Watts, the power consumption should be multiplied by the time the product spends in each mode in order to calculate energy usage. The total product energy usage is the sum of each mode's energy usage.

Laser advisory label

A laser notice label may be affixed to this printer as shown:



European Community (EC) directives conformity

This product is in conformity with the protection requirements of EC Council directives 2004/108/EC and 2006/95/EC on the approximation and harmonization of the laws of the Member States relating to electromagnetic compatibility and safety of electrical equipment designed for use within certain voltage limits.

A declaration of conformity with the requirements of the directives has been signed by the Director of Manufacturing and Technical Support, Lexmark International, Inc., S.A., Boigny, France.

This product satisfies the Class A limits of EN 55022 and safety requirements of EN 60950.

Industry Canada compliance statement

This Class B digital apparatus meets all requirements of the Canadian Interference-Causing Equipment Standard ICES-003.

Avis de conformité aux normes de l'industrie du Canada

Cet appareil numérique de classe B est conforme aux exigences de la norme canadienne relative aux équipements pouvant causer des interférences NMB-003.

Radio interference notice

Warning

This is a product that complies with the emission requirements of EN55022 Class A limits and immunity requirements of EN55024. This product is not intended to be used in residential/domestic environments.

This is a Class A product. In a domestic environment, this product may cause radio interference, in which case the user may be required to take adequate measures.

CCC EMC notice

声 明

此为 A 级产品，在生活环境中，该产品可能会造成无线电干扰。在这种情况下，可能需要用户对其干扰采取切实可行的措施。

BSMI notice

警告使用者：

這是甲類的資訊產品，在居住的環境中使用時，可能會造成無線電干擾，在這種情況下，使用者會被要求採取某些適當的對策。

環境要求	
工作環境	15.6 to 32.2° C (60 to 90° F)
儲存 / 運輸環境	-40° to 40° C (104° F)

Notice to Users in the European Union

Products bearing the CE mark are in conformity with the protection requirements of EC Council directives 2004/108/EC, 2006/95/EC, and 1999/5/EC on the approximation and harmonization of the laws of the Member States relating to electromagnetic compatibility, safety of electrical equipment designed for use within certain voltage limits and on radio equipment and telecommunications terminal equipment.

Compliance is indicated by the CE marking.



A declaration of conformity with the requirements of the directives is available from the Director of Manufacturing and Technical Support, Lexmark International, S. A., Boigny, France.

Refer to the table at the end of the Notices section for further compliance information.

Regulatory notices for wireless products

This section contains the following regulatory information pertaining to wireless products that contain transmitters, for example, but not limited to, wireless network cards or proximity card readers.

Exposure to radio frequency radiation

The radiated output power of this device is far below the radio frequency exposure limits of the FCC and other regulatory agencies. A minimum separation of 20 cm (8 inches) must be maintained between the antenna and any persons for this device to satisfy the RF exposure requirements of the FCC and other regulatory agencies.

Notice to users in Brazil

Este equipamento opera em caráter secundário, isto é, não tem direito a proteção contra interferência prejudicial, mesmo de estações do mesmo tipo, e não pode causar interferência a sistemas operando em caráter primário. (Res. ANATEL 282/2001).

Industry Canada (Canada)

This device complies with Industry Canada specification RSS-210. Operation is subject to the following two conditions: (1) this device may not cause interference, and (2) this device must accept any interference, including interference that may cause undesired operation of the device.

This device has been designed to operate only with the antenna provided. Use of any other antenna is strictly prohibited per regulations of Industry Canada.

To prevent radio interference to the licensed service, this device is intended to be operated indoors and away from windows to provide maximum shielding. Equipment (or its transmit antenna) that is installed outdoors is subject to licensing.

The installer of this radio equipment must ensure that the antenna is located or pointed such that it does not emit RF fields in excess of Health Canada limits for the general population; consult Safety Code 6, obtainable from Health Canada's Web site www.hc-sc.gc.ca/rpb.

The term "IC:" before the certification/registration number only signifies that the Industry Canada technical specifications were met.

Industry Canada (Canada)

Cet appareil est conforme à la norme RSS-210 d'Industry Canada. Son fonctionnement est soumis aux deux conditions suivantes :

(1) cet appareil ne doit pas provoquer d'interférences et (2) il doit accepter toute interférence reçue, y compris celles risquant d'altérer son fonctionnement.

Cet appareil a été conçu pour fonctionner uniquement avec l'antenne fournie. L'utilisation de toute autre antenne est strictement interdite par la réglementation d'Industry Canada.

En application des réglementations d'Industry Canada, l'utilisation d'une antenne de gain supérieur est strictement interdite.

Pour empêcher toute interférence radio au service faisant l'objet d'une licence, cet appareil doit être utilisé à l'intérieur et loin des fenêtres afin de garantir une protection optimale.

Si le matériel (ou son antenne d'émission) est installé à l'extérieur, il doit faire l'objet d'une licence.

L'installateur de cet équipement radio doit veiller à ce que l'antenne soit implantée et dirigée de manière à n'émettre aucun champ HF dépassant les limites fixées pour l'ensemble de la population par Santé Canada. Reportez-vous au Code de sécurité 6 que vous pouvez consulter sur le site Web de Santé Canada www.hc-sc.gc.ca/rpb.

Le terme « IC » précédant le numéro de d'accréditation/inscription signifie simplement que le produit est conforme aux spécifications techniques d'Industry Canada.

Taiwan NCC RF notice statement

NCC型式認證設備注意事項 台灣低功率射頻電機設備之使用注意事項

經型式認證合格之低功率射頻電機，非經許可，公司、商號或使用者均不得擅自變更頻率、加大功率或變更原設計之特性及功能。

低功率射頻電機之使用不得影響飛航安全及干擾合法通信；經發現有干擾現象時，應立即停用，並改善至無干擾時方得繼續使用。前項合法通信，指依電信規定作業之無線電信。低功率射頻電機須忍受合法通信或工業、科學及醫療用電波輻射性電機設備之干擾。

India emissions notice

This device uses very low power low range RF communication that has been tested and found not to cause any interference whatsoever. The manufacturer is not responsible in case of any disputes arising out of requirement of permissions from any local authority, regulatory bodies or any organization, required by the end-user to install and operate this product at his premises.

भारतीय उत्सर्जन सूचना

यह यंत्र बहुत ही कम शक्ति, कम रेंज के RF कम्युनिकेशन का प्रयोग करता है जिसका परीक्षण किया जा चुका है, और यह पाया गया है कि यह किसी भी प्रकार का व्यवधान उत्पन्न नहीं करता। इसके अतिरिक्त प्रयोक्ता द्वारा इस उत्पाद को अपने प्रांगण में स्थापित एवं संचालित करने हेतु किसी स्थानीय प्राधिकरण, निगमक निकायों या किसी संगठन से अनुज्ञा प्राप्त करने की जरूरत के संबंध में उठे विवाद की स्थिति में विनिर्माता जिम्मेदार नहीं है।

Notice to users in the European Union

Products bearing the CE mark are in conformity with the protection requirements of EC Council directives 2004/108/EC, 2006/95/EC, and 1999/5/EC on the approximation and harmonization of the laws of the Member States relating to electromagnetic compatibility, safety of electrical equipment designed for use within certain voltage limits and on radio equipment and telecommunications terminal equipment.

Compliance is indicated by the CE marking.



A declaration of conformity with the requirements of the directives is available from the Director of Manufacturing and Technical Support, Lexmark International, S. A., Boigny, France. Refer to the table at the end of the Notices section for further compliance information.

Products equipped with 2.4GHz Wireless LAN option are in conformity with the protection requirements of EC Council directives 2004/108/EC, 2006/95/EC, and 1999/5/EC on the approximation and harmonization of the laws of the Member States relating to electromagnetic compatibility, safety of electrical equipment designed for use within certain voltage limits and on radio equipment and telecommunications terminal equipment.

Compliance is indicated by the CE marking.



Operation is allowed in all EU and EFTA countries, but is restricted to indoor use only.

A declaration of conformity with the requirements of the directives is available from the Director of Manufacturing and Technical Support, Lexmark International, S. A., Boigny, France. Refer to the table at the end of the Notices section for further compliance information.

Česky	Společnost Lexmark International, Inc. tímto prohlašuje, že výrobek tento výrobek je ve shodě se základními požadavky a dalšími příslušnými ustanoveními směrnice 1999/5/ES.
Dansk	Lexmark International, Inc. erklærer herved, at dette produkt overholder de væsentlige krav og øvrige relevante krav i direktiv 1999/5/EF.
Deutsch	Hiermit erklärt Lexmark International, Inc., dass sich das Gerät dieses Gerät in Übereinstimmung mit den grundlegenden Anforderungen und den übrigen einschlägigen Bestimmungen der Richtlinie 1999/5/EG befindet.
Ελληνική	ΜΕ ΤΗΝ ΠΑΡΟΥΣΑ Η LEXMARK INTERNATIONAL, INC. ΔΗΛΩΝΕΙ ΟΤΙ ΑΥΤΟ ΤΟ ΠΡΟΪΟΝ ΣΥΜΜΟΡΦΩΝΕΤΑΙ ΠΡΟΣ ΤΙΣ ΟΥΣΙΩΔΕΙΣ ΑΠΑΙΤΗΣΕΙΣ ΚΑΙ ΤΙΣ ΛΟΙΠΕΣ ΣΧΕΤΙΚΕΣ ΔΙΑΤΑΞΕΙΣ ΤΗΣ ΟΔΗΓΙΑΣ 1999/5/ΕΚ.
English	Hereby, Lexmark International, Inc., declares that this type of equipment is in compliance with the essential requirements and other relevant provisions of Directive 1999/5/EC.
Español	Por medio de la presente, Lexmark International, Inc. declara que este producto cumple con los requisitos esenciales y cualesquiera otras disposiciones aplicables o exigibles de la Directiva 1999/5/CE.
Eesti	Käesolevaga kinnitab Lexmark International, Inc., et seade see toode vastab direktiivi 1999/5/EÜ põhinõuetele ja nimetatud direktiivist tulenevatele muudele asjakohastele sätetele.

Suomi	Lexmark International, Inc. vakuuttaa täten, että tämä tuote on direktiivin 1999/5/EY oleellisten vaatimusten ja muiden sitä koskevien direktiivin ehtojen mukainen.
Français	Par la présente, Lexmark International, Inc. déclare que l'appareil ce produit est conforme aux exigences fondamentales et autres dispositions pertinentes de la directive 1999/5/CE.
Magyar	Alulírott, Lexmark International, Inc. nyilatkozom, hogy a termék megfelel a vonatkozó alapvető követelményeknek és az 1999/5/EC irányelv egyéb előírásainak.
Íslenska	Hér með lýsir Lexmark International, Inc. yfir því að þessi vara er í samræmi við grunnkröfur og aðrar kröfur, sem gerðar eru í tilskipun 1999/5/EC.
Italiano	Con la presente Lexmark International, Inc. dichiara che questo prodotto è conforme ai requisiti essenziali ed alle altre disposizioni pertinenti stabilite dalla direttiva 1999/5/CE.
Latviski	Ar šo Lexmark International, Inc. deklarē, ka šis izstrādājums atbilst Direktīvas 1999/5/EK būtiskajām prasībām un citiem ar to saistītajiem noteikumiem.
Lietuvių	Šiuo Lexmark International, Inc. deklaruoją, kad šis produktas atitinka esminius reikalavimus ir kitas 1999/5/EB direktyvos nuostatas.
Malti	Bil-preżenti, Lexmark International, Inc., jiddikjara li dan il-prodott huwa konformi mal-ħtiġijiet essenzjali u ma dispożizzjonijiet oħrajn relevanti li jinsabu fid-Direttiva 1999/5/KE.
Nederlands	Hierbij verklaart Lexmark International, Inc. dat het toestel dit product in overeenstemming is met de essentiële eisen en de andere relevante bepalingen van richtlijn 1999/5/EG.
Norsk	Lexmark International, Inc. erklærer herved at dette produktet er i samsvar med de grunnleggende krav og øvrige relevante krav i direktiv 1999/5/EF.
Polski	Niniejszym Lexmark International, Inc. oświadcza, że niniejszy produkt jest zgodny z zasadniczymi wymogami oraz pozostałymi stosownymi postanowieniami Dyrektywy 1999/5/EC.
Português	A Lexmark International Inc. declara que este produto está conforme com os requisitos essenciais e outras disposições da Diretiva 1999/5/CE.
Slovensky	Lexmark International, Inc. týmto vyhlasuje, že tento produkt spĺňa základné požiadavky a všetky príslušné ustanovenia smernice 1999/5/ES.
Slovensko	Lexmark International, Inc. izjavlja, da je ta izdelek v skladu z bistvenimi zahtevami in ostalimi relevantnimi določili direktive 1999/5/ES.
Svenska	Härmed intygar Lexmark International, Inc. att denna produkt står i överensstämmelse med de väsentliga egenskapskrav och övriga relevanta bestämmelser som framgår av direktiv 1999/5/EG.

Statement of Limited Warranty

Lexmark C734n, C734dn, C734dtn, C734dw, C736n, C736dn, C736dtn

Lexmark International, Inc., Lexington, KY

This limited warranty applies to the United States and Canada. For customers outside the U.S., refer to the country-specific warranty information that came with your product.

This limited warranty applies to this product only if it was originally purchased for your use, and not for resale, from Lexmark or a Lexmark Remarketer, referred to in this statement as "Remarketer."

Limited warranty

Lexmark warrants that this product:

- Is manufactured from new parts, or new and serviceable used parts, which perform like new parts
- Is, during normal use, free from defects in material and workmanship

If this product does not function as warranted during the warranty period, contact a Remarketer or Lexmark for repair or replacement (at Lexmark's option).

If this product is a feature or option, this statement applies only when that feature or option is used with the product for which it was intended. To obtain warranty service, you may be required to present the feature or option with the product.

If you transfer this product to another user, warranty service under the terms of this statement is available to that user for the remainder of the warranty period. You should transfer proof of original purchase and this statement to that user.

Limited warranty service

The warranty period starts on the date of original purchase as shown on the purchase receipt and ends 12 months later provided that the warranty period for any supplies and for any maintenance items included with the printer shall end earlier if it, or its original contents, are substantially used up, depleted, or consumed.

To obtain warranty service you may be required to present proof of original purchase. You may be required to deliver your product to the Remarketer or Lexmark, or ship it prepaid and suitably packaged to a Lexmark designated location. You are responsible for loss of, or damage to, a product in transit to the Remarketer or the Lexmark designated location.

When warranty service involves the exchange of a product or part, the item replaced becomes the property of the Remarketer or Lexmark. The replacement may be a new or repaired item.

The replacement item assumes the remaining warranty period of the original product.

Replacement is not available to you if the product you present for exchange is defaced, altered, in need of a repair not included in warranty service, damaged beyond repair, or if the product is not free of all legal obligations, restrictions, liens, and encumbrances.

Before you present this product for warranty service, remove all print cartridges, programs, data, and removable storage media (unless directed otherwise by Lexmark).

For further explanation of your warranty alternatives and the nearest Lexmark authorized servicer in your area contact Lexmark on the World Wide Web at www.lexmark.com/support.

Remote technical support is provided for this product throughout its warranty period. For products no longer covered by a Lexmark warranty, technical support may not be available or only be available for a fee.

Extent of limited warranty

Lexmark does not warrant uninterrupted or error-free operation of any product or the durability or longevity of prints produced by any product.

Warranty service does not include repair of failures caused by:

- Modification or unauthorized attachments
- Accidents, misuse, abuse or use inconsistent with Lexmark user's guides, manuals, instructions or guidance
- Unsuitable physical or operating environment

- Maintenance by anyone other than Lexmark or a Lexmark authorized servicer
- Operation of a product beyond the limit of its duty cycle
- Use of printing media outside of Lexmark specifications
- Refurbishment, repair, refilling or remanufacture by a third party of products, supplies or parts
- Products, supplies, parts, materials (such as toners and inks), software, or interfaces not furnished by Lexmark

TO THE EXTENT PERMITTED BY APPLICABLE LAW, NEITHER LEXMARK NOR ITS THIRD PARTY SUPPLIERS OR REMARKETERS MAKE ANY OTHER WARRANTY OR CONDITION OF ANY KIND, WHETHER EXPRESS OR IMPLIED, WITH RESPECT TO THIS PRODUCT, AND SPECIFICALLY DISCLAIM THE IMPLIED WARRANTIES OR CONDITIONS OF MERCHANTABILITY, FITNESS FOR A PARTICULAR PURPOSE, AND SATISFACTORY QUALITY. ANY WARRANTIES THAT MAY NOT BE DISCLAIMED UNDER APPLICABLE LAW ARE LIMITED IN DURATION TO THE WARRANTY PERIOD. NO WARRANTIES, EXPRESS OR IMPLIED, WILL APPLY AFTER THIS PERIOD. ALL INFORMATION, SPECIFICATIONS, PRICES, AND SERVICES ARE SUBJECT TO CHANGE AT ANY TIME WITHOUT NOTICE.

Limitation of liability

Your sole remedy under this limited warranty is set forth in this document. For any claim concerning performance or nonperformance of Lexmark or a Remarketer for this product under this limited warranty, you may recover actual damages up to the limit set forth in the following paragraph.

Lexmark's liability for actual damages from any cause whatsoever will be limited to the amount you paid for the product that caused the damages. This limitation of liability will not apply to claims by you for bodily injury or damage to real property or tangible personal property for which Lexmark is legally liable. **IN NO EVENT WILL LEXMARK BE LIABLE FOR ANY LOST PROFITS, LOST SAVINGS, INCIDENTAL DAMAGE, OR OTHER ECONOMIC OR CONSEQUENTIAL DAMAGES.** This is true even if you advise Lexmark or a Remarketer of the possibility of such damages. Lexmark is not liable for any claim by you based on a third party claim.

This limitation of remedies also applies to claims against any Suppliers and Remarketers of Lexmark. Lexmark's and its Suppliers' and Remarketers' limitations of remedies are not cumulative. Such Suppliers and Remarketers are intended beneficiaries of this limitation.

Additional rights

Some states do not allow limitations on how long an implied warranty lasts, or do not allow the exclusion or limitation of incidental or consequential damages, so the limitations or exclusions contained above may not apply to you.

This limited warranty gives you specific legal rights. You may also have other rights that vary from state to state.

LEXMARK SOFTWARE LIMITED WARRANTY AND LICENSE AGREEMENTS

PLEASE READ CAREFULLY BEFORE USING THIS PRODUCT: BY USING THIS PRODUCT, YOU AGREE TO BE BOUND BY ALL THE TERMS AND CONDITIONS OF THIS SOFTWARE LIMITED WARRANTY AND LICENSE AGREEMENTS. IF YOU DO NOT AGREE WITH THE TERMS OF THIS SOFTWARE LIMITED WARRANTY AND LICENSE AGREEMENTS, PROMPTLY RETURN THE PRODUCT UNUSED AND REQUEST A REFUND OF THE AMOUNT YOU PAID. IF YOU ARE INSTALLING THIS PRODUCT FOR USE BY OTHER PARTIES, YOU AGREE TO INFORM THE USERS THAT USE OF THE PRODUCT INDICATES ACCEPTANCE OF THESE TERMS.

DEVICE LICENSE AGREEMENT

The patented printer is licensed for, and designed to work with only genuine Lexmark toner cartridges and developer components for the life of the patented printer. Under this patent license, you agree to: (1) use only genuine Lexmark toner cartridges and developer components with this printer except as otherwise provided below, and (2) pass this license/agreement to any subsequent user of this printer. The patented Lexmark toner cartridges and developer components inside are licensed subject to a restriction that they may be used only once. Following their initial use, you agree to return them only to Lexmark for recycling. Lexmark toner cartridges are designed to stop working after a delivering a fixed amount of toner. A variable amount of toner may remain in them when replacement is required. Replacement toner cartridge(s) sold without these terms are available through www.lexmark.com, may be refilled by you, or a third party, as the only cartridge alternative to be used with the licensed printer.

LEXMARK SOFTWARE LICENSE AGREEMENT

This Software License Agreement ("Software License Agreement") is a legal agreement between you (either an individual or a single entity) and Lexmark International, Inc. ("Lexmark") that, to the extent your Lexmark product or Software Program is not otherwise subject to a written software license agreement between you and Lexmark or its suppliers, governs your use of any Software Program installed on or provided by Lexmark for use in connection with your Lexmark product. The term "Software Program" includes machine-readable instructions, audio/visual content (such as images and recordings), and associated media, printed materials and electronic documentation, whether incorporated into, distributed with or for use with your Lexmark product.

- 1 STATEMENT OF SOFTWARE LIMITED WARRANTY.** Lexmark warrants that the media (e.g., diskette or compact disk) on which the Software Program (if any) is furnished is free from defects in materials and workmanship under normal use during the warranty period. The warranty period is ninety (90) days and commences on the date the Software Program is delivered to the original end-user. This limited warranty applies only to Software Program media purchased new from Lexmark or an Authorized Lexmark Reseller or Distributor. Lexmark will replace the Software Program should it be determined that the media does not conform to this limited warranty.
- 2 DISCLAIMER AND LIMITATION OF WARRANTIES.** EXCEPT AS PROVIDED IN THIS SOFTWARE LICENSE AGREEMENT AND TO THE MAXIMUM EXTENT PERMITTED BY APPLICABLE LAW, LEXMARK AND ITS SUPPLIERS PROVIDE THE SOFTWARE PROGRAM "AS IS" AND HEREBY DISCLAIM ALL OTHER WARRANTIES AND CONDITIONS, EITHER EXPRESS OR IMPLIED, INCLUDING, BUT NOT LIMITED TO, TITLE, NON-INFRINGEMENT, MERCHANTABILITY AND FITNESS FOR A PARTICULAR PURPOSE, AND ABSENCE OF VIRUSES, ALL WITH REGARD TO THE SOFTWARE PROGRAM. TO THE EXTENT LEXMARK CANNOT BY LAW DISCLAIM ANY COMPONENT OF THE IMPLIED WARRANTIES OF MERCHANTABILITY OR FITNESS FOR A PARTICULAR PURPOSE, LEXMARK LIMITS THE DURATION OF SUCH WARRANTIES TO THE 90-DAY TERM OF THE EXPRESS SOFTWARE LIMITED WARRANTY.

This Agreement is to be read in conjunction with certain statutory provisions, as that may be in force from time to time, that imply warranties or conditions or impose obligations on Lexmark that cannot be excluded or modified. If any such provisions apply, then to the extent Lexmark is able, Lexmark hereby limits its liability for breach of those provisions to one of the following: providing you a replacement copy of the Software Program or reimbursement of the price paid for the Software Program.

The Software Program may include internet links to other software applications and/or internet web pages hosted and operated by third parties unaffiliated with Lexmark. You acknowledge and agree that Lexmark is not responsible in any way for the hosting, performance, operation, maintenance, or content of, such software applications and/or internet web pages.

3 LIMITATION OF REMEDY. TO THE MAXIMUM EXTENT PERMITTED BY APPLICABLE LAW, ANY AND ALL LIABILITY OF LEXMARK UNDER THIS SOFTWARE LICENSE AGREEMENT IS EXPRESSLY LIMITED TO THE GREATER OF THE PRICE PAID FOR THE SOFTWARE PROGRAM AND FIVE U.S. DOLLARS (OR THE EQUIVALENT IN LOCAL CURRENCY). YOUR SOLE REMEDY AGAINST LEXMARK IN ANY DISPUTE UNDER THIS SOFTWARE LICENSE AGREEMENT SHALL BE TO SEEK TO RECOVER ONE OF THESE AMOUNTS, UPON PAYMENT OF WHICH LEXMARK SHALL BE RELEASED AND DISCHARGED OF ALL FURTHER OBLIGATIONS AND LIABILITY TO YOU.

IN NO EVENT WILL LEXMARK, ITS SUPPLIERS, SUBSIDIARIES, OR RESELLERS BE LIABLE FOR ANY SPECIAL, INCIDENTAL, INDIRECT, EXEMPLARY, PUNITIVE, OR CONSEQUENTIAL DAMAGES (INCLUDING BUT NOT LIMITED TO LOST PROFITS OR REVENUES, LOST SAVINGS, INTERRUPTION OF USE OR ANY LOSS OF, INACCURACY IN, OR DAMAGE TO, DATA OR RECORDS, FOR CLAIMS OF THIRD PARTIES, OR DAMAGE TO REAL OR TANGIBLE PROPERTY, FOR LOSS OF PRIVACY ARISING OUT OR IN ANY WAY RELATED TO THE USE OF OR INABILITY TO USE THE SOFTWARE PROGRAM, OR OTHERWISE IN CONNECTION WITH ANY PROVISION OF THIS SOFTWARE LICENCE AGREEMENT), REGARDLESS OF THE NATURE OF THE CLAIM, INCLUDING BUT NOT LIMITED TO BREACH OF WARRANTY OR CONTRACT, TORT (INCLUDING NEGLIGENCE OR STRICT LIABILITY), AND EVEN IF LEXMARK, OR ITS SUPPLIERS, AFFILIATES, OR REMARKETERS HAVE BEEN ADVISED OF THE POSSIBILITY OF SUCH DAMAGES, OR FOR ANY CLAIM BY YOU BASED ON A THIRD-PARTY CLAIM, EXCEPT TO THE EXTENT THIS EXCLUSION OF DAMAGES IS DETERMINED LEGALLY INVALID. THE FOREGOING LIMITATIONS APPLY EVEN IF THE ABOVE-STATED REMEDIES FAIL OF THEIR ESSENTIAL PURPOSE.

4 U.S.A. STATE LAWS. This Software Limited Warranty gives you specific legal rights. You may also have other rights that vary from state to state. Some states do not allow limitations on how long an implied warranty lasts or the exclusion of limitation of incidental or consequential damages, so the above limitations may not apply to you.

5 LICENSE GRANT. Lexmark grants you the following rights provided you comply with all terms and conditions of this Software License Agreement:

- a Use.** You may Use one (1) copy of the Software Program. The term "Use" means storing, loading, installing, executing, or displaying the Software Program. If Lexmark has licensed the Software Program to you for concurrent use, you must limit the number of authorized users to the number specified in your agreement with Lexmark. You may not separate the components of the Software Program for use on more than one computer. You agree that you will not Use the Software Program, in whole or in part, in any manner that has the effect of overriding, modifying, eliminating, obscuring, altering or de-emphasizing the visual appearance of any trademark, trade name, trade dress or intellectual property notice that appears on any computer display screens normally generated by, or as a result of, the Software Program.
- b Copying.** You may make one (1) copy of the Software Program solely for purposes of backup, archiving, or installation, provided the copy contains all of the original Software Program's proprietary notices. You may not copy the Software Program to any public or distributed network.
- c Reservation of Rights.** The Software Program, including all fonts, is copyrighted and owned by Lexmark International, Inc. and/or its suppliers. Lexmark reserves all rights not expressly granted to you in this Software License Agreement.
- d Freeware.** Notwithstanding the terms and conditions of this Software License Agreement, all or any portion of the Software Program that constitutes software provided under public license by third parties ("Freeware") is licensed to you subject to the terms and conditions of the software license agreement accompanying such Freeware, whether in the form of a discrete agreement, shrink-wrap license, or electronic license terms at the time of download or installation. Use of the Freeware by you shall be governed entirely by the terms and conditions of such license.

- 6 TRANSFER.** You may transfer the Software Program to another end-user. Any transfer must include all software components, media, printed materials, and this Software License Agreement and you may not retain copies of the Software Program or components thereof. The transfer may not be an indirect transfer, such as a consignment. Prior to the transfer, the end-user receiving the transferred Software Program must agree to all these Software License Agreement terms. Upon transfer of the Software Program, your license is automatically terminated. You may not rent, sublicense, or assign the Software Program except to the extent provided in this Software License Agreement.
- 7 UPGRADES.** To Use a Software Program identified as an upgrade, you must first be licensed to the original Software Program identified by Lexmark as eligible for the upgrade. After upgrading, you may no longer use the original Software Program that formed the basis for your upgrade eligibility.
- 8 LIMITATION ON REVERSE ENGINEERING.** You may not alter, decrypt, reverse engineer, reverse assemble, reverse compile or otherwise translate the Software Program or assist or otherwise facilitate others to do so, except as and to the extent expressly permitted to do so by applicable law for the purposes of inter-operability, error correction, and security testing. If you have such statutory rights, you will notify Lexmark in writing of any intended reverse engineering, reverse assembly, or reverse compilation. You may not decrypt the Software Program unless necessary for the legitimate Use of the Software Program.
- 9 ADDITIONAL SOFTWARE.** This Software License Agreement applies to updates or supplements to the original Software Program provided by Lexmark unless Lexmark provides other terms along with the update or supplement.
- 10 TERM.** This Software License Agreement is effective unless terminated or rejected. You may reject or terminate this license at any time by destroying all copies of the Software Program, together with all modifications, documentation, and merged portions in any form, or as otherwise described herein. Lexmark may terminate your license upon notice if you fail to comply with any of the terms of this Software License Agreement. Upon such termination, you agree to destroy all copies of the Software Program together with all modifications, documentation, and merged portions in any form.
- 11 TAXES.** You agree that you are responsible for payment of any taxes including, without limitation, any goods and services and personal property taxes, resulting from this Software License Agreement or your Use of the Software Program.
- 12 LIMITATION ON ACTIONS.** No action, regardless of form, arising out of this Software License Agreement may be brought by either party more than two years after the cause of action has arisen, except as provided under applicable law.
- 13 APPLICABLE LAW.** This Software License Agreement is governed by the laws of the Commonwealth of Kentucky, United States of America. No choice of law rules in any jurisdiction shall apply. The UN Convention on Contracts for the International Sale of Goods shall not apply.
- 14 UNITED STATES GOVERNMENT RESTRICTED RIGHTS.** The Software Program has been developed entirely at private expense. Rights of the United States Government to use the Software Program are as set forth in this Software License Agreement and as restricted in DFARS 252.227-7014 and in similar FAR provisions (or any equivalent agency regulation or contract clause).
- 15 CONSENT TO USE OF DATA.** You agree that Lexmark, its affiliates, and agents may collect and use information you provide in relation to support services performed with respect to the Software Program and requested by you. Lexmark agrees not to use this information in a form that personally identifies you except to the extent necessary to provide such services.
- 16 EXPORT RESTRICTIONS.** You may not (a) acquire, ship, transfer, or reexport, directly or indirectly, the Software Program or any direct product therefrom, in violation of any applicable export laws or (b) permit the Software Program to be used for any purpose prohibited by such export laws, including, without limitation, nuclear, chemical, or biological weapons proliferation.

- 17 AGREEMENT TO CONTRACT ELECTRONICALLY.** You and Lexmark agree to form this Software License Agreement electronically. This means that when you click the “Agree” or “I accept” button on this page or use this product, you acknowledge your agreement to these Software License Agreement terms and conditions and that you are doing so with the intent to “sign” a contract with Lexmark.
- 18 CAPACITY AND AUTHORITY TO CONTRACT.** You represent that you are of the legal age of majority in the place you sign this Software License Agreement and, if applicable, you are duly authorized by your employer or principal to enter into this contract.
- 19 ENTIRE AGREEMENT.** This Software License Agreement (including any addendum or amendment to this Software License Agreement that is included with the Software Program) is the entire agreement between you and Lexmark relating to the Software Program. Except as otherwise provided for herein, these terms and conditions supersede all prior or contemporaneous oral or written communications, proposals, and representations with respect to the Software Program or any other subject matter covered by this Software License Agreement (except to the extent such extraneous terms do not conflict with the terms of this Software License Agreement, any other written agreement signed by you and Lexmark relating to your Use of the Software Program). To the extent any Lexmark policies or programs for support services conflict with the terms of this Software License Agreement, the terms of this Software License Agreement shall control.

MICROSOFT CORPORATION NOTICES

- 1** This product may incorporate intellectual property owned by Microsoft Corporation. The terms and conditions upon which Microsoft is licensing such intellectual property may be found at <http://go.microsoft.com/fwlink/?LinkId=52369>.
- 2** This product is based on Microsoft Print Schema technology. You may find the terms and conditions upon which Microsoft is licensing such intellectual property at <http://go.microsoft.com/fwlink/?LinkId=83288>.

Index

Numerics

1565 Emul Error Load Emul Option 156
2,000-sheet tray installing 35
200–250.yy Paper jam 156
31 Missing or defective <color> cartridge 150
32 Replace unsupported <color> cartridge 150
34 Incorrect paper size, check <src> 150
34 Incorrect paper type, check <src> 150
34 Short paper 150
35 Insufficient memory to support Resource Save feature 151
37 Insufficient memory for Flash Memory Defragment operation 151
37 Insufficient memory to collate job 151
37 Insufficient memory, some held jobs will not be restored 151
38 Memory full 151
39 Page is too complex to print 151
51 Defective flash detected 151
52 Flash full 152
53 Unformatted flash detected 152
54 Network <x> software error 152
54 Serial option <x> error 152
54 Standard network software error 152
55 Unsupported option in slot 152
550-sheet specialty media drawer installing 35
550-sheet tray installing 35
56 Parallel port <x> disabled 152
56 Serial port <x> disabled 153
56 Standard USB port disabled 153
56 USB port <x> disabled 153
57 Configuration change, held jobs were not restored 153
58 Too many flash options installed 153

58 Too many trays attached 153
61 Remove defective hard disk 153
62 Disk full 154
63 Unformatted disk 154
80 Fuser life warning 154
80 Replace fuser 154
82 Replace waste toner box 154
82 Waste toner box missing 154
82 Waste toner box nearly full 154
83 replace transfer module 154
83 transfer module life warning 155
83 Transfer module missing 155
84 <color> photoconductor low 155
84 <color> photoconductor nearly low 155
84 Replace <color> photoconductor 155
88 <color> cartridge low 155
88 <color> cartridge nearly low 155
88 Replace <color> cartridge 155
900–999 Service <message> 156

A

Activating Menu Changes 143
Active NIC menu 103
AppleTalk menu 108
attaching cables 33

B

black-and-white printing 78
brightness, adjusting 53
Busy 143

C

cables
 Ethernet 33
 USB 33
Calibrating 143
calling Customer Support 193
Cancel not available 143
Canceling 143
canceling a job
 from Macintosh 77

 from the printer control panel 77
 from Windows 77
card stock
 tips 72
Change <src> to <x> 143
checking an unresponsive printer 176
checking device status
 on Embedded Web Server 174
checking virtual display
 on Embedded Web Server 173
cleaning
 exterior of the printer 157
 printhead lenses 157
Clearing job accounting statistics 143
Close door <x> 143
Confidential print jobs 72
 printing for Macintosh users 73
 printing for Windows users 73
Confidential Print menu 118
configuration information
 wireless network 39
configurations
 printer 13
Configure MP menu 96
configuring
 port settings 46
conservation settings
 brightness, adjusting 53
 Eco-Mode 51
 Power Saver 52
 Quiet Mode 52
conserving supplies 50
contacting Customer Support 193
Copies 144
Custom Types menu 101

D

Default Source menu 93
Defragmenting Flash 144
Delete 144
Delete all 144
Delete all confidential jobs 144
Deleting 144
directory list
 printing 77
Disabling DLEs 144

- Disabling Menus 144
- Disk Corrupted. Reformat? 144
- Disk recovery x/y XX% 144
- Disk Wiping menu 119
- display 15
- display troubleshooting
 - display is blank 176
 - display shows only diamonds 176
- display, printer control panel
 - adjusting brightness 53
- documents, printing
 - from Macintosh 69
 - from Windows 69

E

- Eco-Mode setting 51
- Embedded Web Server 173
 - administrator settings 173
 - checking device status 174
 - does not open 193
 - networking settings 173
 - setting up e-mail alerts 174
- Embedded Web Server Administrator's Guide 173
- emission notices 196, 197, 199, 200, 201, 202, 203
- Enabling Menus 144
- Encrypting disk x/y XX% 144
- Enter PIN 145
- Enter PIN to lock 145
- envelopes
 - loading 58
 - tips 71
- environmental settings 50
 - brightness, adjusting 53
 - Eco-Mode 51
 - Power Saver 52
 - Quiet Mode 52
- Ethernet networking
 - Macintosh 44
 - Windows 44
- Ethernet port 33
- exterior of the printer
 - cleaning 157
- e-mail
 - notice of low supply level 174
 - notice of paper jam 174
 - notice of paper needed 174
 - notice that different paper is needed 174

F

- factory defaults, restoring 175
- FAQ about color printing 190
- FCC notices 196, 201
- fiber optic
 - network setup 44
- finding information
 - customer support 11
 - publications 11
- Finishing menu 127
- firmware card
 - installing 21
- flash drive 75
- Flash Drive menu 139
- flash memory card
 - installing 21
 - troubleshooting 180
- Flushing buffer 145
- font sample list
 - printing 76
- Formatting Disk x/y XX% 145
- Formatting Flash 145
- fuser or transfer module
 - ordering 160

G

- General Settings menu 121
- guidelines
 - letterhead 69

H

- hard disk with adapter
 - troubleshooting 180
- held jobs 72
 - printing for Macintosh users 73
 - printing for Windows users 73
- Held jobs were not restored 149
- Help menu 141
- HTML menu 137

I

- Image menu 138
- Insert Tray <x> 145
- installation
 - wireless network 40, 41
- installing
 - options in driver 38
 - printer software 37
- installing printer software
 - adding options 38

- internal print server
 - troubleshooting 181
- Internal Solutions Port
 - installing 23
 - troubleshooting 181
- Internal Solutions Port, network
 - changing port settings 46
- Internal System Error, Reload Bookmarks 145
- Internal System Error, Reload Security Certificates 145
- Invalid Engine Code 145
- Invalid Network Code 146
- Invalid PIN 146
- IPv6 menu 107

J

- jam messages
 - clearing instructions, locating 80
- jams
 - avoiding 80
- jams, clearing
 - 200 81
 - 200 or 201 82
 - 201 83
 - 202 84
 - 203 86
 - 230 87
 - 240 88
 - 250 90

L

- labels, paper
 - tips 71
- letterhead
 - guidelines 69
 - loading, multipurpose tray 69
 - loading, trays 69
 - letterhead, printing on
 - for Macintosh users 69
 - for Windows users 69
- LexLink menu 110
- linking trays 61
- Load <src> with <x> 146
- Load multipurpose tray with <x> 146
- loading
 - envelopes 58
 - letterhead in multipurpose tray 69
 - letterhead in trays 69

- multipurpose tray 58
- paper tray 55
- transparencies 58

lock, security 15

M

- Macintosh
 - wireless network installation 41
- max speed and max yield
 - printing 79
- memory card
 - installing 19
 - troubleshooting 181
- menu settings page
 - printing 37
- menus
 - Active NIC 103
 - AppleTalk 108
 - Confidential Print 118
 - Configure MP 96
 - Custom Types 101
 - Default Source 93
 - Disk Wiping 119
 - Finishing 127
 - Flash Drive 139
 - General Settings 121
 - Help 141
 - HTML 137
 - Image 138
 - IPv6 107
 - LexLink 110
 - Miscellaneous 117
 - NetWare 109
 - Network <x> 103
 - Network Card 106
 - Network Reports 105
 - Paper Loading 100
 - Paper Size/Type 93
 - Paper Texture 97
 - Paper Weight 98
 - Parallel <x> menu 112
 - PCL Emul 134
 - PDF 133
 - PictBridge 139
 - PostScript 133
 - Quality 128
 - Reports 102
 - Security Audit Log 120
 - Serial <x> 114
 - Set Date/Time 121
 - Settings 125
 - SMTP Setup menu 116

- Standard Network 103
- Standard USB 110
- Standard USB <x> 110
- Substitute Size 96
- Supplies 92
- TCP/IP 106
- Utilities 132
- Wireless 108
- XPS 133

- Menus are disabled 146
- menus, diagram 91
- Miscellaneous menu 117
- moving the printer 170, 171
- multipurpose tray
 - loading 58

N

- NetWare menu 109
- Network 146
- Network <x> 146
- Network <x> menu 103
- Network Card menu 106
- Network Reports menu 105
- network setup page 37
- Networking Guide 173
- No held jobs 146
- No jobs to cancel 146
- noise
 - reducing 52
- noise emission levels 197
- notices 195, 196, 197, 198, 199, 200, 201, 202, 203

O

- options
 - 2,000-sheet tray 35
 - 550-sheet specialty media
 - drawer 35
 - 550-sheet tray 35
 - firmware card 21
 - firmware cards 17
 - flash memory card 21
 - internal 17
 - Internal Solutions Port 23
 - memory card 19
 - memory cards 17
 - networking 17
 - ports 17
 - printer hard disk 29
- ordering
 - fuser or transfer module 160

- photoconductors 160
- toner cartridges 160
- waste toner box 161

P

- paper
 - characteristics 63
 - letterhead 64
 - preprinted forms 64
 - recycled 50, 65
 - selecting 64
 - setting size 55
 - setting type 55
 - storing 65
 - unacceptable 64
 - Universal Paper Size 101
- paper feed troubleshooting
 - message remains after jam is cleared 182
- paper jams
 - avoiding 80
- paper jams, clearing
 - 200 or 201 82
 - 201 83
 - 202 84
 - 203 86
 - 230 87
 - 240 88
 - 250 90
- Paper Loading menu 100
- Paper Size/Type menu 93
- paper sizes, supported 66
- Paper Texture menu 97
- paper tray
 - loading 55
- paper types
 - supported by printer 67
 - where to load 67
- Paper Weight menu 98
- paper weights
 - supported by printer 67
- Parallel <x> menu 112
- PCL Emul menu 134
- PDF menu 133
- photoconductors
 - ordering 160
- PictBridge menu 139
- PictBridge-enabled printing
 - photos 76
- port settings
 - configuring 46
- PostScript menu 133

- Power Saver 147
 - adjusting 52
 - print job
 - canceling from Macintosh 77
 - canceling from Windows 77
 - print quality
 - cleaning the printhead
 - lenses 157
 - replacing photoconductors 162
 - replacing the waste toner
 - box 169
 - print quality test pages
 - printing 77
 - print quality troubleshooting
 - blank pages 183
 - characters have jagged
 - edges 183
 - clipped images 184
 - color misregistration 184
 - fine horizontal lines 185
 - ghost images 185
 - gray background 185
 - light colored line, white line, or
 - incorrectly colored line 185
 - print irregularities 186
 - print is too dark 186
 - print is too light 187
 - print quality test pages 183
 - repeating defects 187
 - skewed print 188
 - solid color pages 188
 - streaked horizontal lines 188
 - streaked vertical lines 188
 - toner fog or background
 - shading 189
 - toner rubs off 189
 - toner specks 189
 - uneven print density 190
 - print quality, troubleshooting
 - poor transparency quality 189
 - print troubleshooting
 - error reading USB drive 176
 - held jobs do not print 177
 - incorrect characters print 178
 - incorrect margins 185
 - jammed page does not
 - reprint 182
 - job prints from wrong tray 178
 - job prints on wrong paper 178
 - job takes longer than
 - expected 178
 - jobs do not print 176
 - Large jobs do not collate 179
 - multiple-language PDFs do not
 - print 176
 - paper curls badly 186
 - paper frequently jams 182
 - tray linking does not work 178
 - unexpected page breaks
 - occur 179
 - printer
 - configurations 13
 - minimum clearances 12
 - models 13
 - moving 170, 171
 - selecting a location 12
 - setting up in new location 171
 - shipping 172
 - printer control panel 15
 - factory defaults, restoring 175
 - printer hard disk
 - installing 29
 - Printer locked, enter PIN 147
 - printer messages
 - 1565 Emul Error Load Emul
 - Option 156
 - 200–250.yy Paper jam 156
 - 31 Missing or defective <color>
 - cartridge 150
 - 32 Replace unsupported <color>
 - cartridge 150
 - 34 Incorrect paper size, check
 - <src> 150
 - 34 Incorrect paper type, check
 - <src> 150
 - 34 Short paper 150
 - 35 Insufficient memory to support
 - Resource Save feature 151
 - 37 Insufficient memory for Flash
 - Memory Defragment
 - operation 151
 - 37 Insufficient memory to collate
 - job 151
 - 37 Insufficient memory, some held
 - jobs will not be restored 151
 - 38 Memory full 151
 - 39 Page is too complex to
 - print 151
 - 51 Defective flash detected 151
 - 52 Flash full 152
 - 53 Unformatted flash
 - detected 152
 - 54 Network <x> software
 - error 152
 - 54 Serial option <x> error 152
 - 54 Standard network software
 - error 152
 - 55 Unsupported option in
 - slot 152
 - 56 Parallel port <x> disabled 152
 - 56 Serial port <x> disabled 153
 - 56 Standard USB port
 - disabled 153
 - 56 USB port <x> disabled 153
 - 57 Configuration change, held
 - jobs were not restored 153
 - 58 Too many flash options
 - installed 153
 - 58 Too many trays attached 153
 - 61 Remove defective hard
 - disk 153
 - 62 Disk full 154
 - 63 Unformatted disk 154
 - 80 Fuser life warning 154
 - 80 Replace fuser 154
 - 82 Replace waste toner
 - box 154, 169
 - 82 Waste toner box missing 154
 - 82 Waste toner box nearly
 - full 154, 169
 - 83 replace transfer module 154
 - 83 transfer module life
 - warning 155
 - 83 Transfer module missing 155
 - 84 <color> photoconductor
 - low 155, 162
 - 84 <color> photoconductor nearly
 - low 155, 162
 - 84 Replace <color>
 - photoconductor 155, 162
 - 88 <color> cartridge
 - low 155, 165
 - 88 <color> cartridge nearly
 - low 155, 165
 - 88 Replace <color>
 - cartridge 155, 165
 - 900–999 Service <message> 156
- Activating Menu Changes 143
- Busy 143
- Calibrating 143
- Cancel not available 143
- Canceling 143
- Change <src> to <x> 143
- Clearing job accounting
 - statistics 143
- Close door <x> 143

- Copies 144
- Defragmenting Flash 144
- Delete 144
- Delete all 144
- Delete all confidential jobs 144
- Deleting 144
- Disabling DLEs 144
- Disabling Menus 144
- Disk Corrupted. Reformat? 144
- Disk recovery x/y XX% 144
- Enabling Menus 144
- Encrypting disk x/y XX% 144
- Enter PIN 145
- Enter PIN to lock 145
- Flushing buffer 145
- Formatting Disk x/y XX% 145
- Formatting Flash 145
- Held jobs were not restored 149
- Insert Tray <x> 145
- Internal System Error, Reload
 - Bookmarks 145
- Internal System Error, Reload
 - Security Certificates 145
- Invalid Engine Code 145
- Invalid Network Code 146
- Invalid PIN 146
- Load <src> with <x> 146
- Load multipurpose tray with <x> 146
- Menus are disabled 146
- Network 146
- Network <x> 146
- No held jobs 146
- No jobs to cancel 146
- Power Saver 147
- Printer locked, enter PIN 147
- Printing 147
- Programming disk 147
- Programming flash 147
- Programming System Code 147
- Reading USB drive 147
- Ready 147
- Remote Management Active 147
- Remove all color supplies 148
- Remove Packaging Materials 148
- Remove paper from standard bin 148
- Resetting fuser count 148
- Resetting the printer 148
- Restore Held Jobs? 148
- Restoring Factory Defaults 148
- Restoring Held Jobs(s) x/y 149

- Serial <x> 149
- Some held jobs will not be restored 149
- Standard Bin Full 149
- Submitting Selection 149
- Tray <x> Empty 149
- Tray <x> Low 149
- Tray <x> Missing 149
- USB/USB <x> 149
- Waiting 150
- printer options troubleshooting
 - flash memory card 180
 - hard disk with adapter 180
 - internal print server 181
 - Internal Solutions Port 181
 - memory card 181
 - option not working 179
 - trays / drawers 180
 - USB/parallel interface card 181
- printhead lenses
 - cleaning 157
- Printing 147
- printing
 - black-and-white 78
 - directory list 77
 - font sample list 76
 - from flash drive 75
 - from Macintosh 69
 - from Windows 69
 - installing printer software 37
 - max speed and max yield 79
 - menu settings page 37
 - network setup page 37
 - photos 76
 - print quality test pages 77
 - transparencies 70
- printing confidential and other held jobs
 - for Macintosh users 73
 - for Windows users 73
- Programming disk 147
- Programming flash 147
- Programming System Code 147

Q

- Quality menu 128
- Quiet Mode 52
 - print quality troubleshooting 185

R

- Reading USB drive 147

- Ready 147
- recycled paper
 - using 50,65
- recycling
 - Lexmark packaging 54
 - Lexmark products 54
 - toner cartridges 54
 - WEEE statement 197
- Remote Management Active 147
- Remove all color supplies 148
- Remove Packaging Materials 148
- Remove paper from standard bin 148
- Repeat print jobs 72
 - printing for Macintosh users 73
 - printing for Windows users 73
- reports
 - viewing 174
- Reports menu 102
- Reserve print jobs 72
 - printing for Macintosh users 73
 - printing for Windows users 73
- Resetting fuser count 148
- Resetting the printer 148
- Restore Held Jobs? 148
- Restoring Factory Defaults 148
- Restoring Held Jobs(s) x/y 149

S

- safety information 9,10
- Security Audit Log menu 120
- security lock 15
- Serial <x> 149
- Serial <x> menu 114
- serial port 48
- serial printing
 - setting up 48
- Set Date/Time menu 121
- setting
 - paper size 55
 - paper type 55
 - TCP/IP address 106
- setting up
 - serial printing 48
- setting up the printer
 - on a wired network (Macintosh) 44
 - on a wired network (Windows) 44
- Settings menu 125
- shipping the printer 172
- SMTP Setup menu 116

- Some held jobs will not be restored 149
- Standard Bin Full 149
- Standard Network menu 103
- Standard USB <x> menu 110
- Standard USB menu 110
- status of supplies, checking 159, 160
- storing
 - paper 65
 - supplies 159
- Submitting Selection 149
- Substitute Size menu 96
- supplies
 - conserving 50
 - status 159
 - status of 160
 - storing 159
 - using recycled paper 50
- Supplies menu 92
- supplies, ordering
 - fuser or transfer module 160
 - photoconductors 160
 - toner cartridges 160
 - waste toner box 161
- system board
 - accessing 18
- system board cover
 - reinstalling 32

T

- TCP/IP menu 106
- telecommunication notices 200
- tips
 - card stock 72
 - envelopes 71
 - labels, paper 71
- toner cartridge(s)
 - replacing 165
- toner cartridges
 - ordering 160
 - recycling 54
- transparencies
 - loading 58
 - printing 70
- Tray <x> Empty 149
- Tray <x> Low 149
- Tray <x> Missing 149
- trays
 - linking 61
 - unlinking 61

- troubleshooting
 - checking an unresponsive printer 176
 - contacting Customer Support 193
 - FAQ about color printing 190
- troubleshooting, display
 - display is blank 176
 - display shows only diamonds 176
- troubleshooting, paper feed
 - message remains after jam is cleared 182
- troubleshooting, print
 - error reading USB drive 176
 - held jobs do not print 177
 - incorrect characters print 178
 - incorrect margins 185
 - jammed page does not reprint 182
 - job prints from wrong tray 178
 - job prints on wrong paper 178
 - job takes longer than expected 178
 - jobs do not print 176
 - Large jobs do not collate 179
 - multiple-language PDFs do not print 176
 - paper curls badly 186
 - paper frequently jams 182
 - tray linking does not work 178
 - unexpected page breaks occur 179
- troubleshooting, print quality
 - blank pages 183
 - characters have jagged edges 183
 - clipped images 184
 - color misregistration 184
 - fine horizontal lines 185
 - ghost images 185
 - gray background 185
 - light colored line, white line, or incorrectly colored line 185
 - poor transparency quality 189
 - print irregularities 186
 - print is too dark 186
 - print is too light 187
 - print quality test pages 183
 - repeating defects 187
 - skewed print 188
 - solid color pages 188

- streaked horizontal lines 188
- streaked vertical lines 188
- toner fog or background shading 189
- toner rubs off 189
- toner specks 189
- uneven print density 190
- troubleshooting, printer options
 - flash memory card 180
 - hard disk with adapter 180
 - internal print server 181
 - Internal Solutions Port 181
 - memory card 181
 - option not working 179
 - trays / drawers 180
 - USB/parallel interface card 181

U

- Universal Paper Size 101
- Universal Setup menu 101
- unlinking trays 61
- USB port 33
- USB/USB <x> 149
- Utilities menu 132

V

- Verify print jobs 72
 - printing for Macintosh users 73
 - printing for Windows users 73
- viewing
 - reports 174
- virtual display
 - how to access 173

W

- Waiting 150
- waste toner box
 - ordering 161
 - replacing 169
- Windows
 - wireless network installation 40
- wired network setup
 - using Windows 44
- wired networking
 - using Macintosh 44
- Wireless menu 108
- wireless network
 - configuration information 39
 - installation, using Macintosh 41
 - installation, using Windows 40

X

XPS menu 133