



C54x Series

User's Guide

Contents

Safety information.....	9
Learning about the printer.....	10
Finding information about the printer.....	10
Printer configurations.....	11
Selecting a location for the printer.....	12
Understanding the printer control panel.....	14
Additional printer setup.....	15
Installing internal options.....	15
Available options	15
Accessing the system board to install internal options.....	16
Installing a memory card	19
Installing a flash memory card.....	21
Installing hardware options.....	23
Installing a 650-sheet duo drawer	23
Attaching cables.....	24
Verifying printer setup.....	25
Printing menu settings pages	25
Printing a network setup page	26
Setting up the printer software.....	26
Installing printer software	26
Updating available options in the printer driver.....	27
Setting up wireless printing.....	28
Information you will need to set up the printer on a wireless network.....	28
Installing the printer on a wireless network (Windows)	29
Installing the printer on a wireless network (Macintosh).....	30
Installing the printer on a wired network	33
Loading paper and specialty media.....	36
Linking and unlinking trays.....	36
Linking trays.....	36
Unlinking trays.....	36
Assigning a Custom Type <x> name.....	36
Setting the Paper Size and Paper Type.....	37
Configuring Universal paper settings.....	37
Loading the standard 250-sheet tray.....	38
Loading the optional 650-sheet duo drawer.....	40

Using the multipurpose feeder.....	41
Using the manual feeder.....	44
Paper and specialty media guide.....	46
Paper guidelines.....	46
Paper characteristics.....	46
Unacceptable paper	47
Selecting paper.....	47
Selecting preprinted forms and letterhead.....	47
Storing paper.....	48
Supported paper sizes, types, and weights.....	48
Paper sizes supported by the printer	48
Paper types supported by the printer	50
Paper types and weights supported by the printer	50
Paper capacities.....	52
Using recycled paper and other office papers	52
Printing.....	54
Printing a document.....	54
Printing specialty documents.....	55
Tips on using letterhead.....	55
Tips on using transparencies	56
Tips on using envelopes.....	57
Tips on using paper labels.....	57
Tips on using card stock.....	58
Printing from a flash drive.....	59
Printing information pages.....	60
Printing a font sample list.....	60
Printing a directory list.....	60
Printing the print quality test pages	60
Canceling a print job from the printer control panel	60
Canceling a print job from the computer	61
Clearing jams.....	63
Avoiding jams.....	63
Understanding jam numbers and locations.....	64
200 paper jam.....	65
201 paper jam.....	65
202 paper jam.....	66
230 paper jam.....	68
235 paper jam.....	68

242 paper jam.....	68
250 paper jam.....	69
Understanding printer menus.....	70
Menu list.....	70
Supplies menu.....	71
Paper menu.....	71
Default Source menu.....	71
Paper Size/Type menu.....	72
Paper Texture menu.....	75
Paper Weight menu.....	76
Paper Loading menu.....	78
Custom Types menu.....	79
Universal Setup menu.....	80
Reports.....	81
Menu Settings Page menu.....	81
Device Statistics menu.....	81
Network Setup Page menu.....	81
Profile List menu.....	81
Print Fonts menu.....	81
Print Directory menu.....	82
Print Defects menu.....	82
Print Demo menu.....	82
Asset Report menu.....	82
Network/Ports.....	82
Active NIC menu.....	82
Network menu.....	83
Wireless menu.....	84
USB menu.....	84
Settings.....	86
General Settings menu.....	86
Setup menu.....	89
Finishing menu.....	89
Quality menu.....	91
Utilities menu.....	94
PDF menu.....	95
PostScript menu.....	95
PCL Emul menu.....	96
Image menu.....	98
PictBridge menu.....	99
Flash drive menu.....	100

Understanding printer messages.....	101
List of status and error messages.....	101
Maintaining the printer.....	111
Storing supplies.....	111
Conserving supplies.....	111
Checking the status of supplies.....	111
Checking the status of supplies from the printer control panel.....	111
Checking the status of supplies from a network computer	111
Ordering supplies.....	112
Ordering toner cartridges.....	112
Ordering imaging kits	113
Ordering a waste toner bottle.....	113
Replacing supplies.....	114
Replacing the waste toner bottle	114
Replacing a black imaging kit	117
Replacing a black and color imaging kit	123
Replacing a toner cartridge.....	128
Replacing a developer unit	130
Cleaning the exterior of the printer.....	135
Recycling Lexmark products.....	136
Moving the printer.....	136
Before moving the printer	136
Moving the printer to another location.....	136
Shipping the printer	136
Administrative support.....	137
Restoring the factory default settings.....	137
Adjusting Power Saver.....	137
Using the Embedded Web Server.....	138
Setting up e-mail alerts.....	138
Configuring supply notifications.....	138
Copying printer settings to other printers.....	139
Troubleshooting.....	140
Solving basic printer problems.....	140
Solving printing problems.....	140
Printer control panel display is blank or displays only diamonds.....	140
Error message about reading USB drive appears.....	140

Jobs do not print.....	140
Job takes longer than expected to print.....	141
Job prints from the wrong tray or on the wrong paper	141
Incorrect characters print.....	141
Tray linking does not work.....	142
Large jobs do not collate	142
Unexpected page breaks occur.....	142
Solving option problems.....	143
Option does not operate correctly or quits after it is installed	143
Drawers.....	143
Flash memory card.....	143
Multipurpose feeder	144
Memory card	144
Solving paper feed problems.....	144
Paper frequently jams	144
Paper jam message remains after jam is cleared	145
Page that jammed does not reprint after you clear the jam.....	145
Solving print quality problems.....	145
Isolating print quality problems.....	145
Blank pages.....	146
Characters have jagged or uneven edges	146
Clipped images.....	147
Dark lines	147
Gray background	147
Incorrect margins.....	148
Light colored line, white line, or incorrectly colored line.....	148
Paper curl.....	149
Print irregularities	149
Print is too dark.....	150
Print is too light	151
Repeating defects.....	152
Skewed print.....	153
Solid color pages.....	153
Toner fog or background shading appears on the page	153
Toner rubs off.....	153
Toner specks.....	154
Transparency print quality is poor.....	154
Uneven print density.....	155
Solving color quality problems.....	155
Color misregistration.....	155
FAQ about color printing.....	156
Contacting Customer Support.....	159

Notices..... 160
Product information..... 160
Edition notice..... 160
Industry Canada notices..... 163
Power consumption..... 168

Index..... 176

Safety information

Connect the power cord to a properly grounded electrical outlet that is near the product and easily accessible.

Do not place or use this product near water or wet locations.

 **CAUTION—POTENTIAL INJURY:** This product uses a laser. Use of controls or adjustments or performance of procedures other than those specified herein may result in hazardous radiation exposure.

This product uses a printing process that heats the print media, and the heat may cause the media to release emissions. You must understand the section in your operating instructions that discusses the guidelines for selecting print media to avoid the possibility of harmful emissions.

 **CAUTION—HOT SURFACE:** The inside of the printer might be hot. To reduce the risk of injury from a hot component, allow the surface to cool before touching.

 **CAUTION—POTENTIAL INJURY:** The printer weight is greater than 18 kg (40 lb) and requires two or more trained personnel to move it safely.

 **CAUTION—POTENTIAL INJURY:** Before moving the printer, follow these guidelines to avoid personal injury or printer damage:

- Turn the printer off using the power switch, and then unplug the power cord from the wall outlet.
- Disconnect all cords and cables from the printer before moving it.
- Lift the printer off of the optional drawer and set it aside instead of trying to lift the drawer and printer at the same time.

Note: Use the handholds located on both sides of the printer to lift it off the optional drawer.

Use only the power cord provided with this product or the manufacturer's authorized replacement.

Use only the telecommunications (RJ-11) cord provided with this product or a 26 AWG or larger replacement when connecting this product to the public switched telephone network.

 **CAUTION—SHOCK HAZARD:** If you are accessing the system board or installing optional hardware or memory devices sometime after setting up the printer, then turn the printer off, and unplug the power cord from the wall outlet before continuing. If you have any other devices attached to the printer, then turn them off as well, and unplug any cables going into the printer.

 **CAUTION—SHOCK HAZARD:** Make sure that all external connections (such as Ethernet and telephone system connections) are properly installed in their marked plug-in ports.

This product is designed, tested, and approved to meet strict global safety standards with the use of specific manufacturer's components. The safety features of some parts may not always be obvious. The manufacturer is not responsible for the use of other replacement parts.

 **CAUTION—POTENTIAL INJURY:** Do not twist, bind, crush, or place heavy objects on the power cord. Do not subject the power cord to abrasion or stress. Do not pinch the power cord between objects such as furniture and walls. If the power cord is misused, a risk of fire or electrical shock results. Inspect the power cord regularly for signs of misuse. Remove the power cord from the electrical outlet before inspecting it.

Refer service or repairs, other than those described in the user documentation, to a professional service person.

 **CAUTION—SHOCK HAZARD:** To avoid the risk of electric shock when cleaning the exterior of the printer, unplug the power cord from the wall outlet and disconnect all cables from the printer before proceeding.

SAVE THESE INSTRUCTIONS.

Learning about the printer

Finding information about the printer

Setup information

Description	Where to find
The <i>Setup</i> information gives you instructions for setting up the printer. Follow the set of instructions for local, network, or wireless, depending on what you need.	You can find the <i>Setup</i> information on the side of the printer box or on the Lexmark Web site at www.lexmark.com .

Help

Description	Where to find
The Help gives you instructions for using the software.	While in any Lexmark software program, click Help , Tips → Help , or Help → Help Topics .

Customer support

Description	Where to find (North America)	Where to find (rest of world)
Telephone support	<p>Call us at</p> <ul style="list-style-type: none">US: 1-800-332-4120 Monday–Friday (8:00 AM–11:00 PM ET) Saturday (Noon–6:00 PM ET)Canada: 1-800-539-6275 Monday–Friday (8:00 AM–11:00 PM ET) Saturday (Noon–6:00 PM ET)Mexico: 001-888-377-0063 Monday–Friday (8:00 AM–8:00 PM ET) <p>Note: Telephone numbers and support times may change without notice. For the most recent telephone numbers available, see the printed warranty statement that came with your printer.</p>	<p>Telephone numbers and support hours vary by country or region.</p> <p>Visit our Web site at www.lexmark.com. Select a country or region, and then select the Customer Support link.</p> <p>Note: For additional information about contacting Lexmark, see the printed warranty that came with your printer.</p>

Description	Where to find (North America)	Where to find (rest of world)
E-mail support	<p>For e-mail support, visit our Web site: www.lexmark.com.</p> <ol style="list-style-type: none"> 1 Click SUPPORT. 2 Click Technical Support. 3 Select your printer type. 4 Select your printer model. 5 From the Support Tools section, click e-Mail Support. 6 Complete the form, and then click Submit Request. 	<p>E-mail support varies by country or region, and may not be available in some instances.</p> <p>Visit our Web site at www.lexmark.com. Select a country or region, and then select the Customer Support link.</p> <p>Note: For additional information about contacting Lexmark, see the printed warranty that came with your printer.</p>

Printer configurations

Basic model

The following illustration shows the basic printer model:

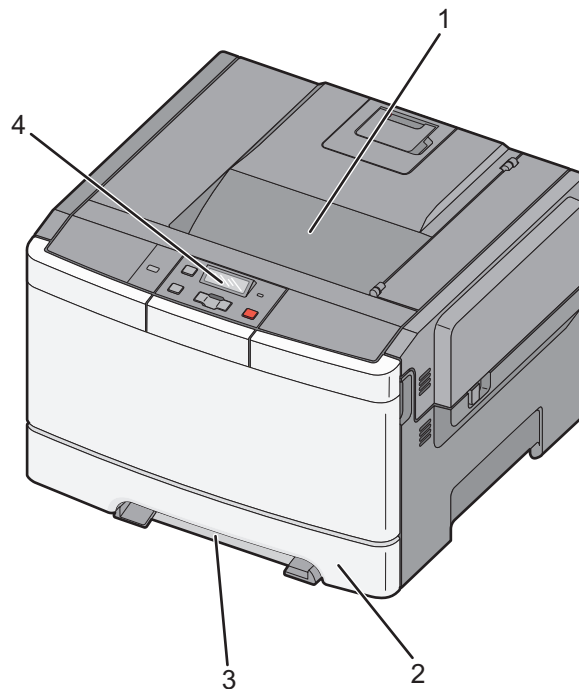

1	Standard exit bin
2	Standard 250-sheet tray (Tray 1)
3	Manual feeder
4	Printer control panel

Fully configured model

The following illustration shows the fully configured printer model with a 650-sheet duo drawer:

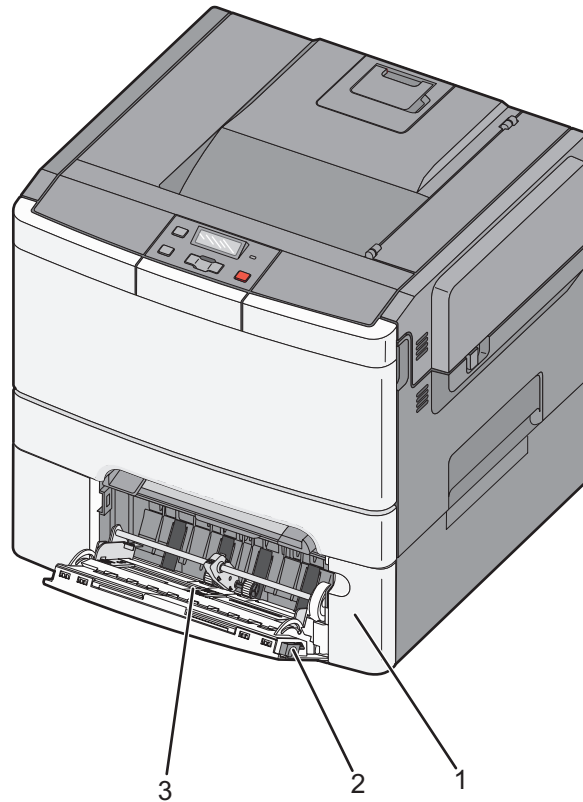

1	650-sheet duo drawer (Tray 2)
2	Multipurpose feeder latch
3	Multipurpose feeder

Selecting a location for the printer

When selecting a location for the printer, leave enough room to open trays, covers, and doors. If you plan to install any options, leave enough room for them also. It is important to:

- Make sure airflow in the room meets the latest revision of the ASHRAE 62 standard.
- Provide a flat, sturdy, and stable surface.
- Keep the printer:
 - Away from the direct airflow of air conditioners, heaters, or ventilators
 - Free from direct sunlight, humidity extremes, or temperature fluctuations
 - Clean, dry, and free of dust
- Allow the following recommended amount of space around the printer for proper ventilation:

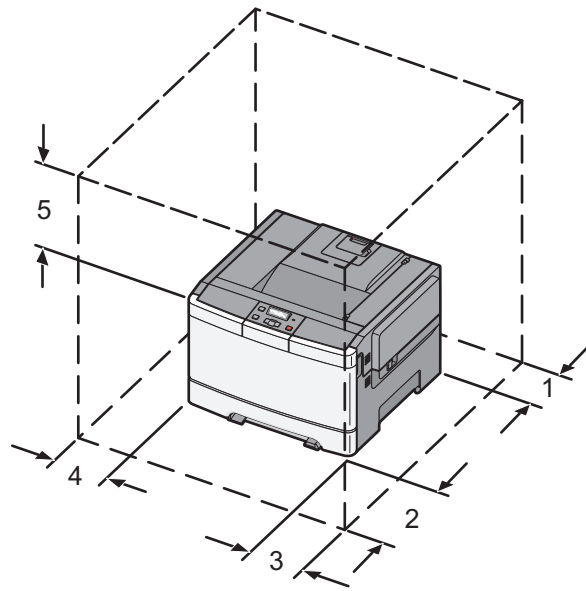







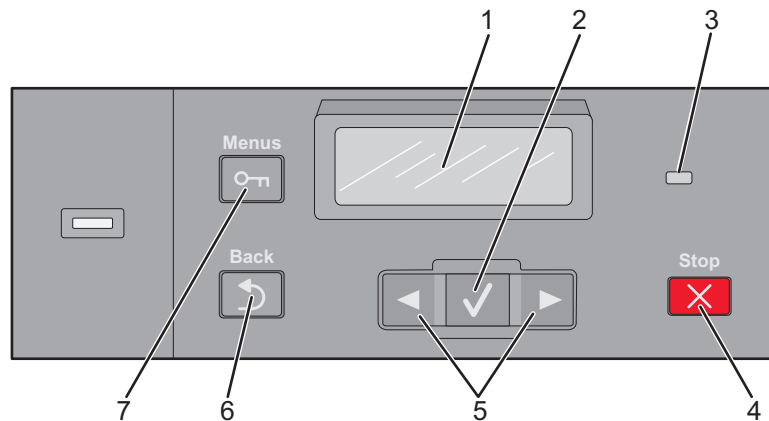

1	304.8 mm (12.0 in.)
2	508 mm (20.0 in.)
3	304.8 mm (12.0 in.)
4	304.8 mm (12.0 in.)
5	508 mm (20.0 in.)

When the printer is set up, allow clearance around it as shown.

Understanding the printer control panel



Control panel item		Description
1	Display	Shows messages that communicate the status of the printer
2	Select 	Press  to initiate action on a menu item.
3	Indicator light	Indicates the printer status: <ul style="list-style-type: none"> • Off—The power is off. • Blinking green—The printer is warming up, processing data, or printing. • Solid green—The printer is on, but idle. • Blinking red—Operator intervention is needed.
4	Stop/Cancel 	Stops all printer activity A list of options is offered once Stopped appears on the display.
5	Navigation buttons 	Press  or  to scroll through menu lists.
6	Back 	Returns the display to the previous screen
7	Menu 	Opens the menu index Note: The menus are available only when the printer is in the Ready state.

Additional printer setup

Installing internal options

 **CAUTION—SHOCK HAZARD:** If you are accessing the system board or installing optional hardware or memory devices sometime after setting up the printer, then turn the printer off, and unplug the power cord from the wall outlet before continuing. If you have any other devices attached to the printer, then turn them off as well, and unplug any cables going into the printer.

You can customize your printer connectivity and memory capacity by adding optional cards. The instructions in this section explain how to install the available cards; you can also use them to locate a card for removal.

Note: Options are available only for some printer models.

Available options

Note: Certain options are not available on selected printer models.

Memory cards

- Printer memory
- Flash memory
- Font cards

Accessing the system board to install internal options

CAUTION—SHOCK HAZARD: If you are accessing the system board or installing optional hardware or memory devices sometime after setting up the printer, then turn the printer off, and unplug the power cord from the wall outlet before continuing. If you have any other devices attached to the printer, then turn them off as well, and unplug any cables going into the printer.

Note: This operation requires a #2 Phillips screwdriver.

- 1 Remove the cover.
 - a Turn the screws on the cover counterclockwise, and then remove them.

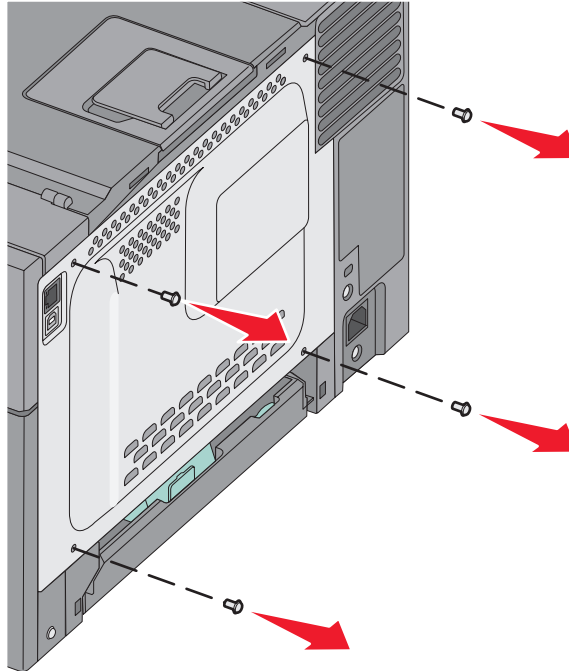

- b** Gently pull the cover away from the printer, and then remove it.

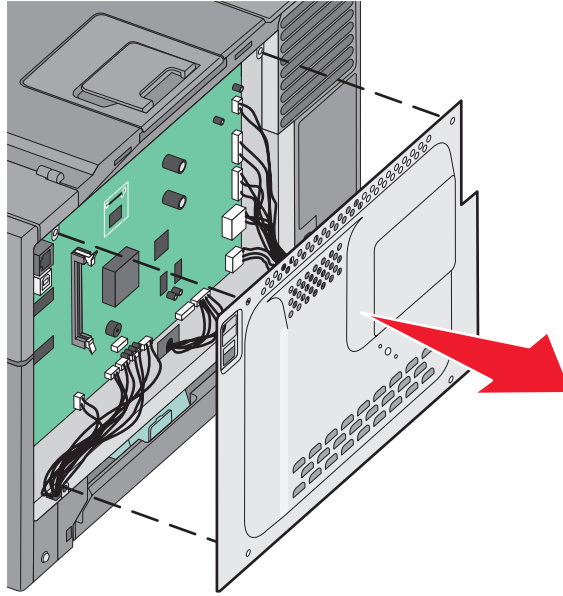

2 Use the illustration below to locate the appropriate connector.

Warning—Potential Damage: System board electrical components are easily damaged by static electricity. Touch something metal on the printer before touching any system board electronic components or connectors.

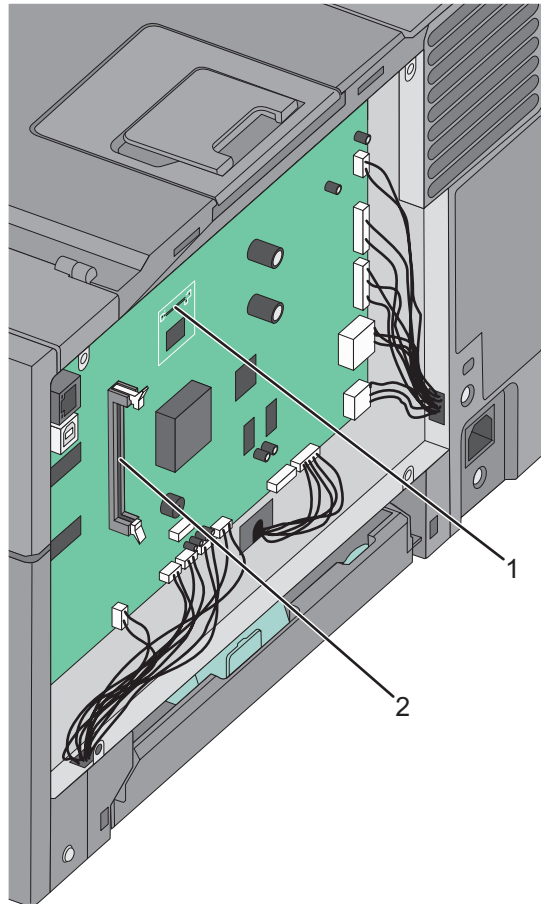

1	Flash memory card connector
2	Memory card connector

Installing a memory card

The system board has one connector for an optional memory card.

⚠ CAUTION—SHOCK HAZARD: If you are accessing the system board or installing optional hardware or memory devices sometime after setting up the printer, then turn the printer off, and unplug the power cord from the wall outlet before continuing. If you have any other devices attached to the printer, then turn them off as well, and unplug any cables going into the printer.

- 1 Access the system board.

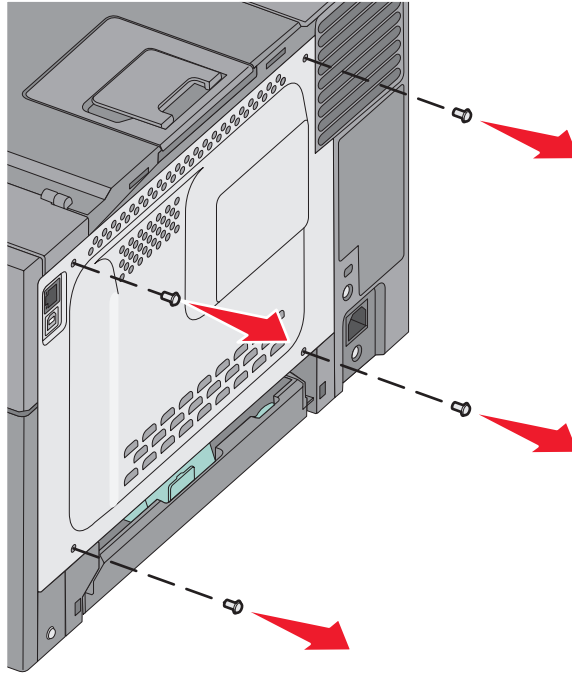

2 Open both latches on the connector completely.

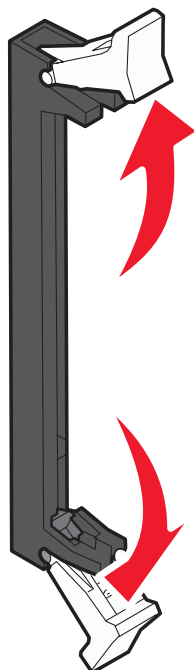

3 Unpack the memory card.

Note: Avoid touching the connection points along the edge of the card.

4 Align the notches on the memory card with the ridges on the connector.

5 Push the memory card straight into the connector until it *snaps* into place. Make sure each latch fits over the notch located on either side of the memory card.

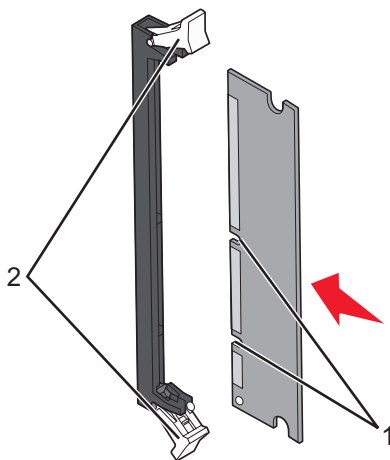

1	Notch
2	Latch

6 Reinstall the system board access cover.

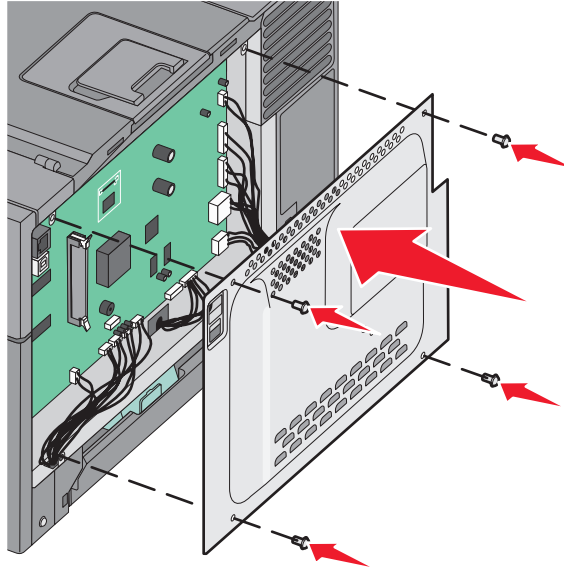

Installing a flash memory card

⚠ CAUTION—SHOCK HAZARD: If you are accessing the system board or installing optional hardware or memory devices sometime after setting up the printer, then turn the printer off, and unplug the power cord from the wall outlet before continuing. If you have any other devices attached to the printer, then turn them off as well, and unplug any cables going into the printer.

1 Access the system board.

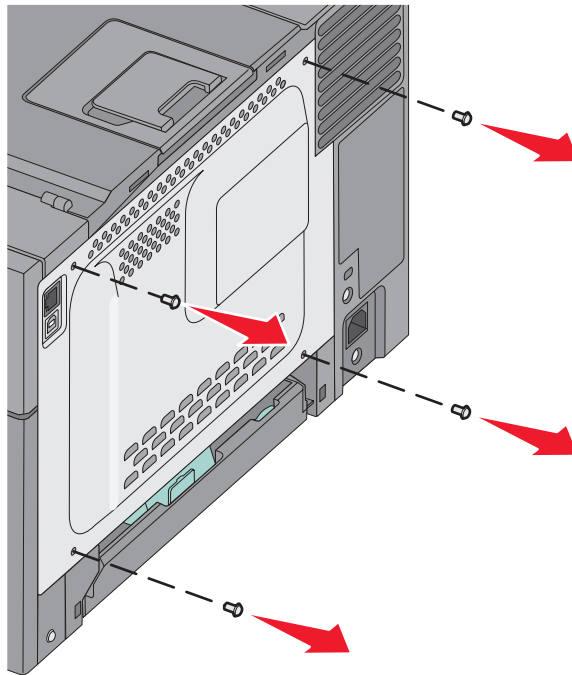

2 Unpack the memory card.

Note: Avoid touching the connection points along the edge of the card.

3 Holding the card by its sides, align the plastic pins on the card with the holes on the system board. This ensures the metal pins line up correctly as well.

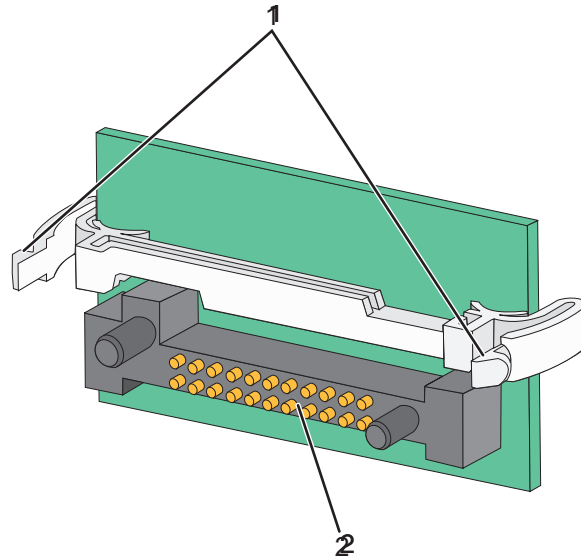

1	Plastic pins
2	Metal pins

4 Push the card firmly into place.

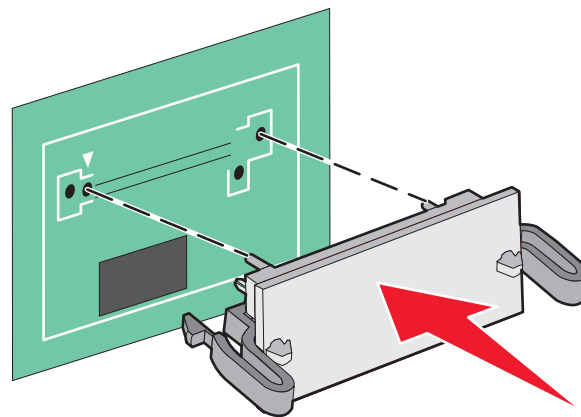

Notes:

- The entire length of the connector on the card must touch and be flush against the system board.
- Be careful not to damage the connectors.

- 5 Reinstall the system board cover.

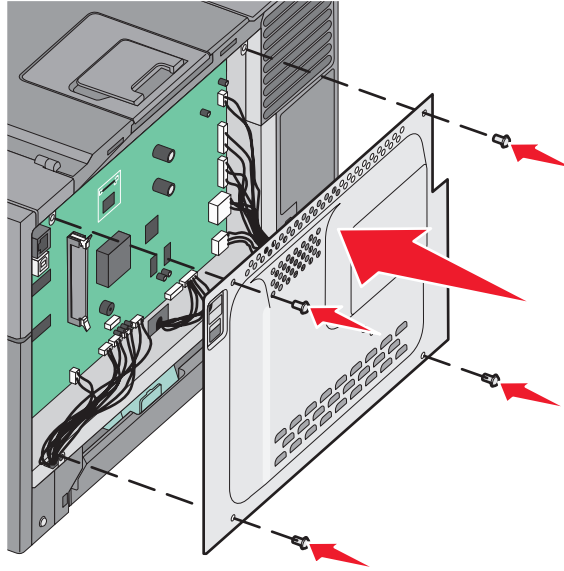

Installing hardware options

Installing a 650-sheet duo drawer

The printer supports one optional drawer, which allows an additional 650 sheets of paper to be loaded. The drawer includes a multipurpose feeder.

CAUTION—SHOCK HAZARD: If you are accessing the system board or installing optional hardware or memory devices sometime after setting up the printer, then turn the printer off, and unplug the power cord from the wall outlet before continuing. If you have any other devices attached to the printer, then turn them off as well, and unplug any cables going into the printer.

- 1 Unpack the 650-sheet duo drawer, and remove any packing material and the dust cover.
- 2 Place the drawer in the location chosen for the printer.
- 3 Align the printer with the 650-sheet duo drawer, and lower the printer into place.

CAUTION—POTENTIAL INJURY: The printer weight is great than 18 kg (40 lb) and requires two or more trained personnel to move it safely.

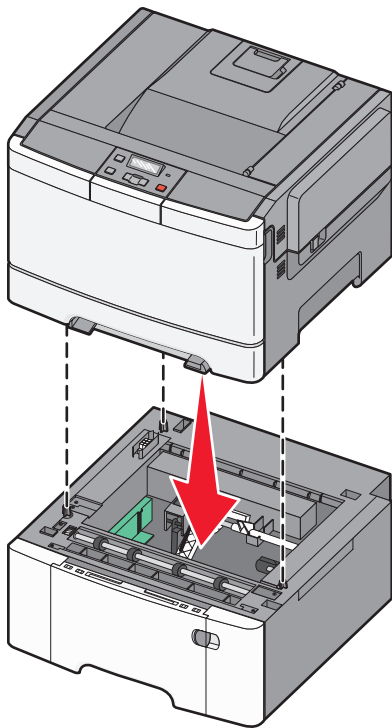

Attaching cables

Connect the printer to the computer using a USB cable or an Ethernet cable. A USB port requires a USB cable. Be sure to match the USB symbol on the cable with the USB symbol on the printer. Match the appropriate Ethernet cable to the Ethernet port.

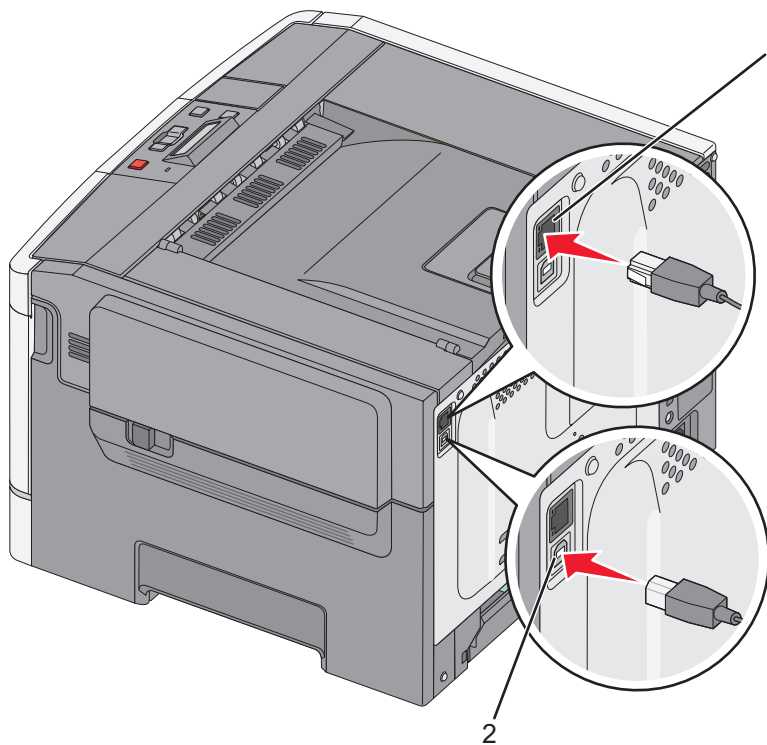

1	Ethernet port
2	USB port

Verifying printer setup

Once all hardware and software options are installed and the printer is turned on, verify that the printer is set up correctly by printing the following:



- **Menu settings pages**—Use these pages to verify that all printer options are installed correctly. A list of installed options appears toward the bottom of the page. If an option you installed is not listed, then it is not installed correctly. Remove the option and install it again.
- **Network setup page**—If your printer is a network model and is attached to a network, print a network setup page to verify the network connection. This page also provides important information that aids network printing configuration.

Printing menu settings pages

Print menu settings pages to review the current menu settings and to verify printer options are installed correctly.



Note: If you have not made any menu item settings changes yet, then the menu settings pages list all the factory default settings. Once you select and save other settings from the menus, they replace the factory default settings as *user default settings*. A user default setting remains in effect until you access the menu again, choose another value, and save it. To restore the factory default settings, see “Restoring the factory default settings” on page 137.

- 1 Make sure the printer is on and **Ready** appears.
- 2 From the printer control panel, press .

- 3 Press the arrow buttons until **Reports** appears, and then press .
- 4 Press the arrow buttons until **Menu Settings Page** appears, and then press .
After the menu settings pages print, **Ready** appears.

Printing a network setup page

If the printer is attached to a network, print a network setup page to verify the network connection. This page also provides important information that aids network printing configuration.

- 1 Make sure the printer is on and **Ready** appears.
- 2 From the printer control panel, press .
- 3 Press the arrow buttons until **Reports** appears, and then press .
- 4 Press the arrow buttons until **Network Setup Page** appears, and then press .
After the network setup page prints, **Ready** appears.
- 5 Check the first section on the network setup page, and confirm that Status is "Connected."
If Status is "Not Connected," the LAN drop may not be active, or the network cable may be malfunctioning. Consult a system support person for a solution, and then print another network setup page.

Setting up the printer software

Installing printer software

A printer driver is software that lets the computer communicate with the printer. The printer software is typically installed during the initial printer setup. If you need to install the software after setup, follow these instructions:

For Windows users

- 1 Close all open software programs.
- 2 Insert the *Software and Documentation* CD.
- 3 From the main installation dialog, click **Install**.
- 4 Follow the instructions on the screen.

For Macintosh users

- 1 Close all open software applications.
- 2 Insert the *Software and Documentation* CD.
- 3 From the Finder desktop, double-click the printer CD icon that automatically appears.
- 4 Double-click the **Install** icon.
- 5 Follow the instructions on the screen.

Using the World Wide Web

- 1 Go to the Lexmark Web site at **www.lexmark.com**.
- 2 From the Drivers & Downloads menu, click **Driver Finder**.
- 3 Select your printer, and then select your operating system.
- 4 Download the driver and install the printer software.

Updating available options in the printer driver

Once the printer software and any options are installed, it may be necessary to manually add the options in the printer driver to make them available for print jobs.

For Windows users

- 1 Do one of the following:

In Windows Vista

- a Click .
- b Click **Control Panel**.
- c Click **Hardware and Sound**.
- d Click **Printers**.

In Windows XP

- a Click **Start**.
- b Click **Printers and Faxes**.

In Windows 2000

- a Click **Start**.
- b Click **Settings → Printers**.

- 2 Select the printer.
- 3 Right-click the printer, and then select **Properties**.
- 4 Click the Install Options tab.
- 5 Under Available Options, add any installed hardware options.
- 6 Click **Apply**.

For Macintosh users

In Mac OS X version 10.5

- 1 From the Apple menu, choose **System Preferences**.
- 2 Click **Print & Fax**.
- 3 Select the printer, and then click **Options & Supplies**.

4 Click **Driver**, and then add any installed hardware options.

5 Click **OK**.

In Mac OS X version 10.4 and earlier

1 From the Go menu, choose **Applications**.

2 Double-click **Utilities**, and then double-click **Print Center** or **Printer Setup Utility**.

3 Select the printer, and then from the Printers menu, choose **Show Info**.

4 From the pop-up menu, choose **Installable Options**.

5 Add any installed hardware options, and then click **Apply Changes**.

Setting up wireless printing

Information you will need to set up the printer on a wireless network

Note: Do not connect the installation or network cables until prompted to do so by the setup software.

- **SSID**—The SSID is also referred to as the network name.
- **Wireless Mode (or Network Mode)**—The mode will be either infrastructure or ad hoc.
- **Channel (for ad hoc networks)**—The channel defaults to auto for infrastructure networks.

Some ad hoc networks will also require the auto setting. Check with your system support person if you are not sure which channel to select.

- **Security Method**—There are three basic options for Security Method:
 - WEP key
If your network uses more than one WEP key, enter up to four in the provided spaces. Select the key currently in use on the network by selecting the Default WEP Transmit Key.
or
 - WPA or WPA2 passphrase
WPA includes encryption as an additional layer of security. The choices are AES or TKIP. Encryption must be set for the same type on the router and on the printer, or the printer will not be able to communicate on the network.
 - No security
If your wireless network does not use any type of security, then you will not have any security information.

Note: Using an unsecured wireless network is not recommended.

If you are installing the printer on an 802.1X network using the Advanced method, then you may need the following:

- Authentication type
- Inner authentication type
- 802.1X username and password
- Certificates

Note: For more information on configuring 802.1X security, see the *Networking Guide* on the *Software and Documentation CD*.

Installing the printer on a wireless network (Windows)

Before you install the printer on a wireless network, make sure that:

- Your wireless network is set up and working properly.
- The computer you are using is connected to the same wireless network where you want to set up the printer.

1 Connect the power cable, and then turn the printer on.

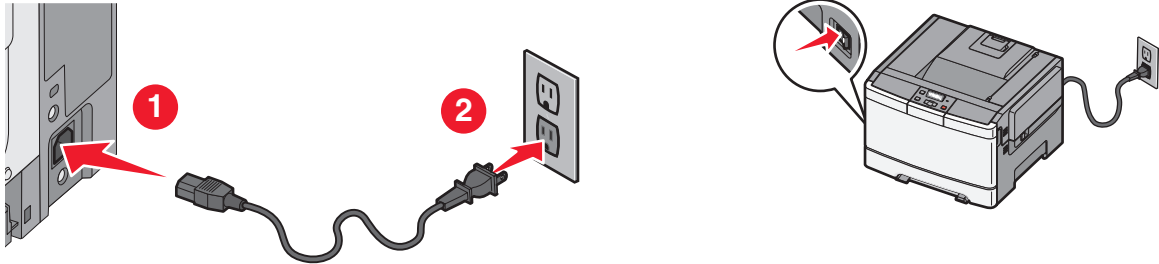

Make sure the printer and computer are fully on and ready.



Do not connect the USB cable until instructed to do so on the screen

2 Insert the *Software and Documentation* CD.

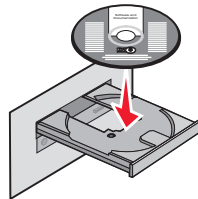

3 Click **Install**.

4 Click **Agree**.

5 Click **Suggested**.

6 Click **Wireless Network Attach**.

7 Connect the cables in the following order:

- a Temporarily connect a USB cable between the computer on the wireless network and the printer.

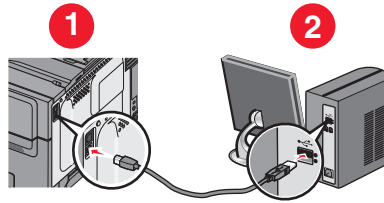

Note: After the printer is configured, the software will instruct you to disconnect the temporary USB cable so you can print wirelessly.

- b If your printer has faxing capabilities, then connect the telephone cable.

8 Follow the on-screen instructions to complete the software installation.

9 To allow other computers on the wireless network to use the wireless printer, follow steps 2 through 6 and step 8 for each computer.

Installing the printer on a wireless network (Macintosh)

Prepare to configure the printer

1 Locate the printer MAC address on the sheet that came with the printer. Write the last six digits of the MAC address in the space provided below:

MAC address: _____

2 If your printer has faxing capabilities, then connect the telephone cable.

3 Connect the power cable, and then turn the power on.

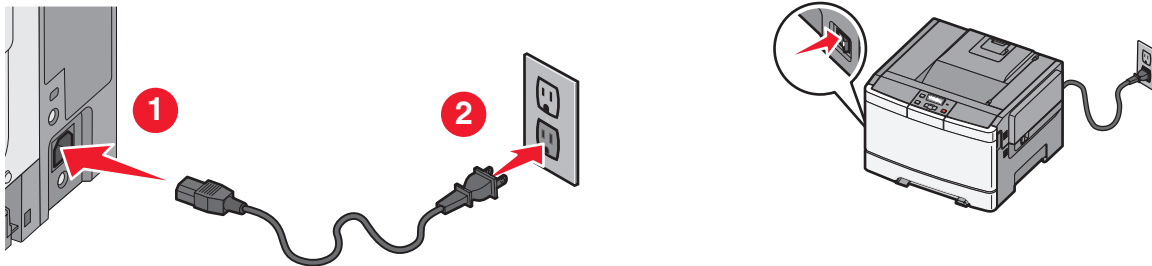

Enter the printer information

1 Access the AirPort options.

In Mac OS X version 10.5

- a From the Apple menu, choose **System Preferences**.
- b Click **Network**.
- c Click **AirPort**.

In Mac OS X version 10.4 and earlier

- a From the Go menu, choose **Applications**.
 - b Double-click **Internet Connect**.
 - c From the toolbar, click **AirPort**.
- 2 From the Network pop-up menu, select **print server xxxxxx**, where the x's are the last six digits of the MAC address located on the MAC address sheet.
- 3 Open the Safari browser.
- 4 From the Bookmarks drop-down menu, select **Show**.
- 5 Under Collections, select **Bonjour** or **Rendevous**, and then double-click the printer name.
- 6 From the main page of the Embedded Web Server, navigate to the page where the wireless settings information is stored.

Configure the printer for wireless access

- 1 Type the name of your network (SSID) in the appropriate field.
- 2 Select **Infrastructure** as your Network Mode if you are using a wireless router.
- 3 Select the type of security you use to protect your wireless network.
- 4 Enter the security information necessary for the printer to join your wireless network.
- 5 Click **Submit**.
- 6 Open the AirPort application on your computer:

In Mac OS X version 10.5

- a From the Apple menu, choose **System Preferences**.
- b Click **Network**.
- c Click **AirPort**.

In Mac OS X version 10.4 and earlier

- a From the Go menu, choose **Applications**.
 - b Double-click **Internet Connect**.
 - c From the toolbar, click **AirPort**.
- 7 From the Network pop-up menu, select your wireless network.

Configure your computer to use the printer wirelessly

To print to a network printer, each Macintosh user must install a custom *PostScript Printer Description* (PPD) file and create a printer in the Print Center or Printer Setup Utility.

- 1 Install a PPD file on the computer:
 - a Insert the *Software and Documentation* CD in the CD or DVD drive.
 - b Double-click the installer package for the printer.
 - c From the Welcome screen, click **Continue**.
 - d Click **Continue** again after viewing the Readme file.

- e** Click **Continue** after viewing the license agreement, and then click **Agree** to accept the terms of the agreement.
 - f** Select a Destination, and then click **Continue**.
 - g** From the Easy Install screen, click **Install**.
 - h** Type the user password, and then click **OK**.
All necessary software is installed on the computer.
 - i** Click **Close** when installation is complete.
- 2** Add the printer:
- a** For IP printing:

In Mac OS X version 10.5

- 1** From the Apple menu, choose **System Preferences**.
- 2** Click **Print & Fax**.
- 3** Click **+**.
- 4** Select the printer from the list.
- 5** Click **Add**.

In Mac OS X version 10.4

- 1** From the Go menu, choose **Applications**.
- 2** Double-click **Utilities**.
- 3** Locate and double-click **Printer Setup Utility** or **Print Center**.
- 4** From the Printer List, choose **Add**.
- 5** Select the printer from the list.
- 6** Click **Add**.

- b** For AppleTalk printing:

In Mac OS X version 10.5

- 1** From the Apple menu, choose **System Preferences**.
- 2** Click **Print & Fax**.
- 3** Click **+**.
- 4** Click **AppleTalk**.
- 5** Select the printer from the list.
- 6** Click **Add**.

In Mac OS X version 10.4

- 1** From the Go menu, choose **Applications**.
- 2** Double-click **Utilities**.
- 3** Locate and double-click **Print Center** or **Printer Setup Utility**.
- 4** From the Printer List, choose **Add**.
- 5** Choose the **Default Browser** tab.
- 6** Click **More Printers**.
- 7** From the first pop-up menu, choose **AppleTalk**.
- 8** From the second pop-up menu, select **Local AppleTalk zone**.

- 9 Select the printer from the list.
- 10 Click **Add**.

Installing the printer on a wired network

Use the following instructions to install the printer on a wired network. These instructions apply to Ethernet and fiber optic network connections.

Before you install the printer on a wired network, make sure that:

- You have completed the initial setup of the printer.
- The printer is connected to your network with the appropriate type of cable.

For Windows users

- 1 Insert the *Software and Documentation* CD.

Wait for the Welcome screen to appear.

If the CD does not launch after a minute, then do one of the following:

In Windows Vista

- a Click .
- b In the Start Search box, type `D:\setup.exe`, where **D** is the letter of your CD or DVD drive.

In Windows XP and earlier

- a Click **Start**.
- b Click **Run**.
- c Type `D:\setup.exe`, where **D** is the letter of your CD or DVD drive.

- 2 Click **Install Printer and Software**.
- 3 Click **Agree** to agree to the License Agreement.
- 4 Select **Suggested**, and then click **Next**.

Note: To configure the printer using a static IP address, using IPv6, or to configure printers using scripts, select **Custom** and follow the on-screen instructions.

- 5 Select **Wired Network Attach**, and then click **Next**.
- 6 Select the printer manufacturer from the list.
- 7 Select the printer model from the list, and then click **Next**.
- 8 Select the printer from the list of printers discovered on the network, and then click **Finish**.

Note: If your configured printer does not appear in the list of discovered printers, click **Add Port** and follow the on-screen instructions.

- 9 Follow the on-screen instructions to complete the installation.

For Macintosh users

- 1 Allow the network DHCP server to assign an IP address to the printer.
- 2 Print the network setup page from the printer. For information on printing a network setup page, see “Printing a network setup page” on page 26.
- 3 Locate the printer IP address in the TCP/IP section of the network setup page. You will need the IP address if you are configuring access for computers on a different subnet than the printer.
- 4 Install the drivers and add the printer.
 - a Install a PPD file on the computer:
 - 1 Insert the *Software and Documentation* CD in the CD or DVD drive.
 - 2 Double-click the installer package for the printer.
 - 3 From the Welcome screen, click **Continue**.
 - 4 Click **Continue** again after viewing the Readme file.
 - 5 Click **Continue** after viewing the license agreement, and then click **Agree** to accept the terms of the agreement.
 - 6 Select a Destination, and then click **Continue**.
 - 7 From the Easy Install screen, click **Install**.
 - 8 Type the user password, and then click **OK**.
All the necessary software is installed on the computer.
 - 9 Click **Close** when installation is complete.

b Add the printer:

- For IP printing:

In Mac OS X version 10.5

- 1 From the Apple menu, choose **System Preferences**.
- 2 Click **Print & Fax**.
- 3 Click **+**.
- 4 Select the printer from the list.
- 5 Click **Add**.

In Mac OS X version 10.4 and earlier

- 1 From the Go menu, choose **Applications**.
- 2 Double-click **Utilities**.
- 3 Double-click **Printer Setup Utility** or **Print Center**.
- 4 From the Printer List, click **Add**.
- 5 Select the printer from the list.
- 6 Click **Add**.

- For AppleTalk printing:

In Mac OS X version 10.5

- 1 From the Apple menu, choose **System Preferences**.
- 2 Click **Print & Fax**.
- 3 Click **+**.
- 4 Click **AppleTalk**.

- 5 Select the printer from the list.
- 6 Click **Add**.

In Mac OS X version 10.4 and earlier

- 1 From the Go menu, choose **Applications**.
- 2 Double-click **Utilities**.
- 3 Double-click **Print Center** or **Printer Setup Utility**.
- 4 From the Printer List, click **Add**.
- 5 Choose the **Default Browser** tab.
- 6 Click **More Printers**.
- 7 From the first pop-up menu, choose **AppleTalk**.
- 8 From the second pop-up menu, select **Local AppleTalk zone**.
- 9 Select the printer from the list.
- 10 Click **Add**.

Note: If the printer doesn't show up in the list, you may need to add it using the IP address. Contact your system support person for assistance.

Loading paper and specialty media

This section explains how to load the 250-sheet tray and 650-sheet duo drawer, the multipurpose feeder, and the manual feeder. It also includes information about paper orientation, setting the Paper Size and Paper Type, and linking and unlinking trays.

Linking and unlinking trays

Linking trays

Tray linking is useful for large print jobs or multiple copies. When one linked tray is empty, paper feeds from the next linked tray. When the Paper Size and Paper Type settings are the same for any trays, the trays are automatically linked. The Paper Size setting for all trays must be set manually from the Paper Size menu. The Paper Type setting must be set for all trays from the Paper Type menu. The Paper Type menu and the Paper Size menu are both available from the Paper Size/Type menu.

Unlinking trays

Unlinked trays have settings that are *not* the same as the settings of any other tray.





To unlink a tray, change the following tray settings so that they do not match the settings of any other tray:



- Paper Type (for example: Plain Paper, Letterhead, Custom Type <x>)
Paper Type names describe the paper characteristics. If the name that best describes your paper is used by linked trays, assign a different Paper Type name to the tray, such as Custom Type <x>, or define your own custom name.
- Paper Size (for example: letter, A4, statement)
Load a different paper size to change the Paper Size setting for a tray. Paper Size settings are not automatic; they must be set manually from the Paper Size menu.

Warning—Potential Damage: Do not assign a Paper Type name that does not accurately describe the type of paper loaded in the tray. The temperature of the fuser varies according to the specified Paper Type. Paper may not be properly processed if an inaccurate Paper Type is selected.

Assigning a Custom Type <x> name

Assign a Custom Type <x> name to a tray to link or unlink it. Associate the same Custom Type <x> name to each tray that you want to link. Only trays with the same custom names assigned will link.











- 1 Make sure the printer is on and **Ready** appears.
- 2 From the printer control panel, press .
- 3 Press the arrow buttons until **Paper Menu** appears, and then press .
- 4 Press the arrow buttons until **Size/Type** appears, and then press .
- 5 Press the arrow buttons, and then press  to select the tray.
The Paper Size menu appears.
- 6 Press the arrow buttons until the Paper Type menu appears.
- 7 Press .

- 8 Press the arrow buttons until **Custom Type <x>** or another custom name appears, and then press . **Submitting changes** appears, followed by **Paper Menu**.
- 9 Press , and then press  to return to the **Ready** state.

Setting the Paper Size and Paper Type

Note: Trays with matching Paper Size and Paper Type settings are automatically linked by the printer. When a linked tray runs out of paper, the printer draws from another tray.

To change the Paper Size and Paper Type settings:

- 1 Make sure the printer is on and **Ready** appears.
- 2 From the printer control panel, press .
- 3 Press the arrow buttons until **Paper Menu** appears, and then press .
- 4 Press the arrow buttons until **Size/Type** appears, and then press .
- 5 Press the arrow buttons until the correct tray appears, and then press .
- 6 Press  when **Size** appears.
- 7 Press the arrow buttons until the correct size appears, and then press . **Submitting changes** appears, followed by **Size**.
- 8 Press the arrow buttons until **Type** appears, and then press .
- 9 Press the arrow buttons until the correct type appears, and then press . **Submitting changes** appears, followed by **Type**.
- 10 Press , and then press  to return to the **Ready** state.



Configuring Universal paper settings

The Universal Paper Size is a user-defined setting that lets you print on paper sizes that are not preset in the printer menus. Set the Paper Size for the specified tray to Universal when the size you want is not available from the Paper Size menu. Then, specify all of the following Universal size settings for your paper:

- Units of measure (inches or millimeters)
- Portrait Height and Portrait Width
- Feed Direction

Note: The smallest supported Universal size is 76.2 x 127 mm (3 x 5 in.); the largest is 215.9 x 355.6 mm (8.5 x 14 in.).

Specify a unit of measurement

- 1 Make sure the printer is on and **Ready** appears.
- 2 From the printer control panel, press .
- 3 Press the arrow buttons until **Paper Menu** appears, and then press .
- 4 Press the arrow buttons until **Universal Setup** appears, and then press .

- 5 Press the arrow buttons until **Units of Measure** appears, and then press .
 - 6 Press the arrow buttons until the correct unit of measure appears, and then press .
- Submitting changes** appears, followed by the **Universal Setup** menu.

Specify the paper height and width

Defining a specific height and width measurement for the Universal paper size (in the portrait orientation) allows the printer to support the size, including support for standard features such as duplex printing and printing multiple pages on one sheet.

- 1 From the Universal Setup menu, press the arrow buttons until **Portrait Width** or **Portrait Height** appears, and then press .

Note: Select **Portrait Height** to adjust the paper height setting or **Paper Width** to adjust the paper width setting.

- 2 Press the arrow buttons to decrease or to increase the setting, and then press .
- Submitting changes** appears, followed by the **Universal Setup** menu.

Loading the standard 250-sheet tray

The printer has one standard 250-sheet tray (Tray 1) and may have an optional 650-sheet duo drawer. The 250-sheet tray and 650-sheet duo drawer support the same paper sizes and types.

- 1 Pull the tray out.

Note: Do not remove trays while a job prints or while **Busy** appears on the display. Doing so may cause a jam.

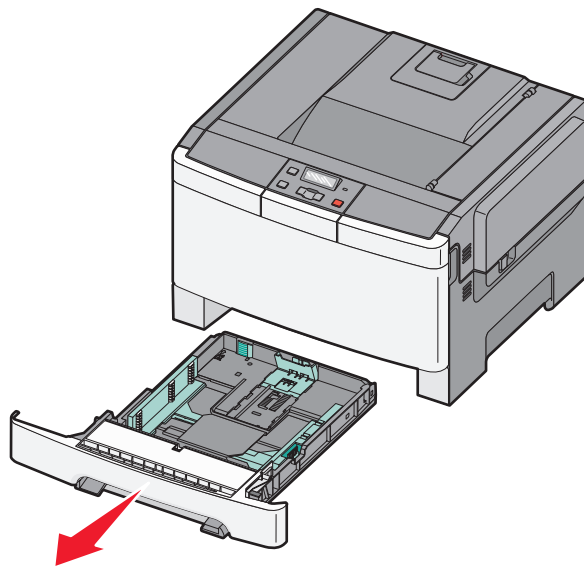

- 2 Squeeze the length guide tab inward as shown, and slide the guide to the correct position for the paper size being loaded.

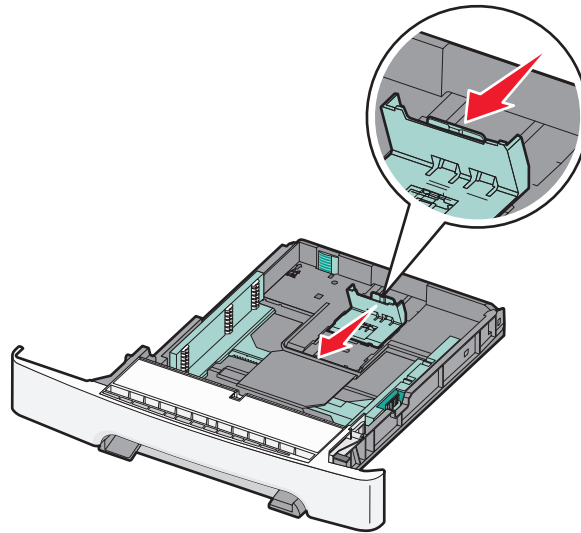

Note: Use the size indicators on the bottom of the tray to help position the guide.

- 3 If the paper is longer than letter-size paper, push the green tab at the back of the tray to elongate it.

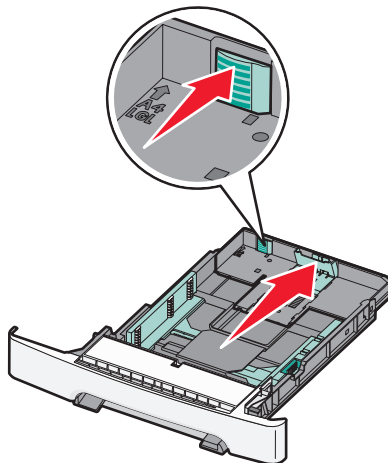

- 4 Flex the sheets back and forth to loosen them, and then fan them. Do not fold or crease the paper. Straighten the edges on a level surface.

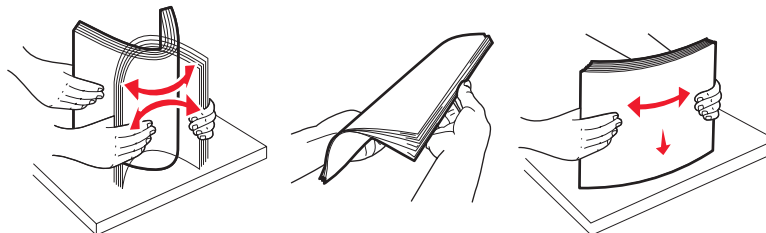

- 5 Load the paper stack with the recommended print side faceup.

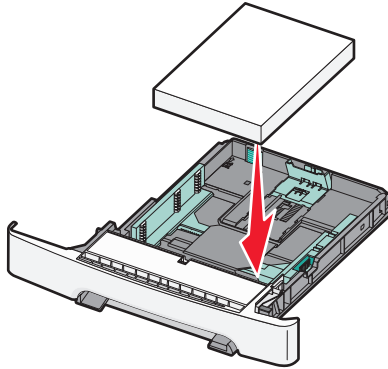

- 6 Make sure the paper guides are secure against the edges of the paper.

Note: Make sure that side guides are placed tightly against the edges of the paper so that the image is registered properly on the page.

- 7 Insert the tray.

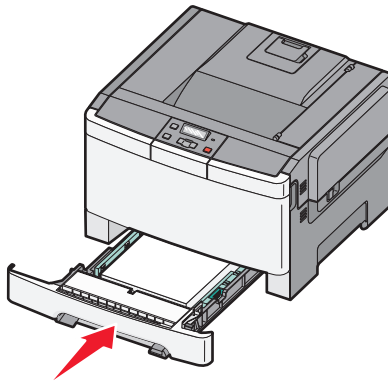

- 8 If a different type or size of paper was loaded than the type or size previously loaded in the tray, change the Paper Type or Paper Size setting for the tray from the printer control panel.

Note: Mixing paper sizes or types in a paper tray may lead to jams.

Loading the optional 650-sheet duo drawer

The 650-sheet duo drawer consists of a 550-sheet tray and a 100-sheet multipurpose feeder. This drawer is loaded in the same way that the standard tray is loaded. The only differences are the look of the guide tabs and the location of the paper size indicators, as shown in the following illustration:

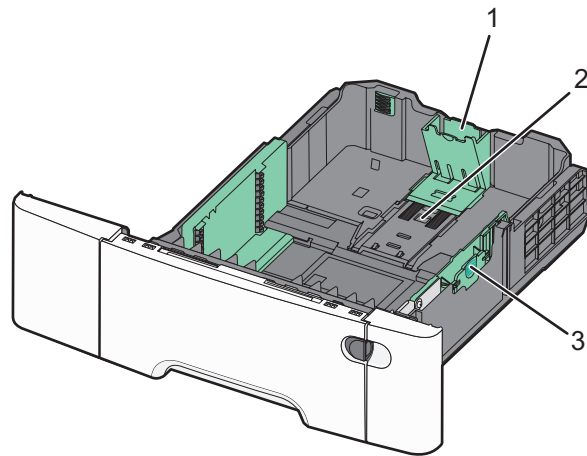

1	Length guide tabs
2	Size indicators
3	Width guide tabs

Using the multipurpose feeder

1 Push the multipurpose feeder latch to the left.

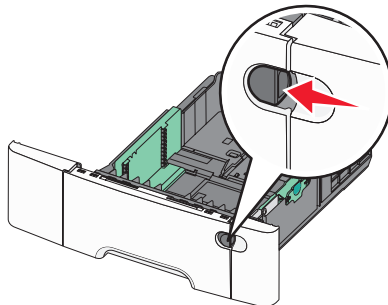

2 Open the multipurpose feeder.

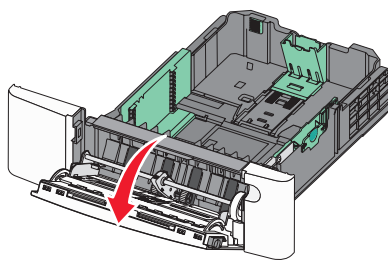

3 Grasp the extension, and pull it straight out until it is fully extended.

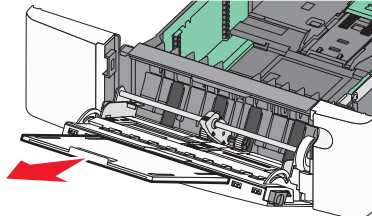

4 Prepare the paper for loading.

- Flex sheets of paper back and forth to loosen them, and then fan them. Do not fold or crease the paper. Straighten the edges on a level surface.

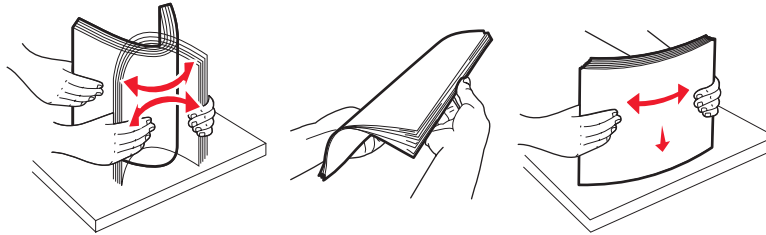

- Hold transparencies by the edges and fan them. Straighten the edges on a level surface.

Note: Avoid touching the print side of transparencies. Be careful not to scratch them.

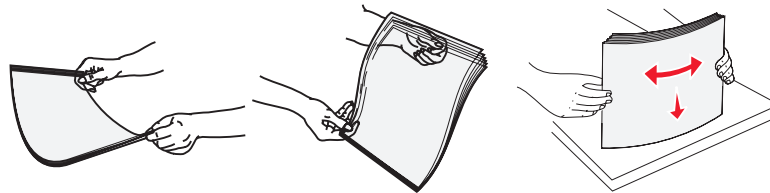

- Flex a stack of envelopes back and forth to loosen them, and then fan them. Straighten the edges on a level surface.

5 Locate the stack height limiter and tab.

Note: Do not exceed the maximum stack height by forcing paper under the stack height limiter.

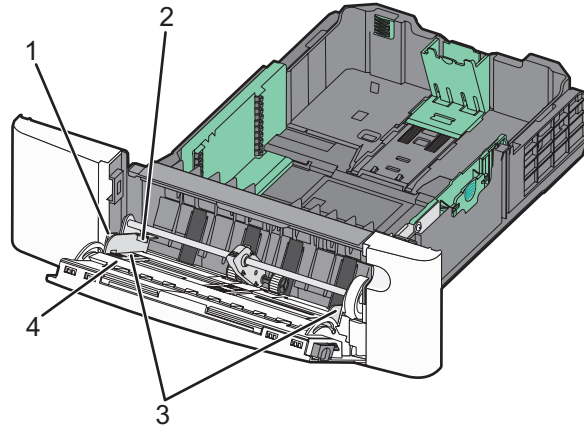

1	Tab
2	Stack height limiter
3	Width guide
4	Size indicators

6 Load the paper, and then adjust the width guide to lightly touch the edge of the paper stack.

- Load paper, card stock, and transparencies with the recommended print side facedown and the top edge entering first.

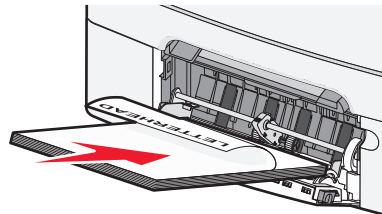

- Load envelopes with the flap side up.

Warning—Potential Damage: Never use envelopes with stamps, clasps, snaps, windows, coated linings, or self-stick adhesives. These envelopes may severely damage the printer..

Notes:

- Do not load or close the multipurpose feeder while a job is printing.
- Load only one size and type of paper at a time.

7 Make sure the paper is as far into the multipurpose feeder as it will go with very gentle pushing. Paper should lie flat in the multipurpose feeder. Make sure the paper fits loosely in the multipurpose feeder and is not bent or wrinkled.

8 From the printer control panel, set the Paper Size and Paper Type.

Using the manual feeder

1 Send a manual print job:

For Windows users:

- a With a document open, click **File → Print**.
- b Click **Properties, Preferences, Options, or Setup**.
- c Select **Manual Paper**.
- d Click **OK**.
- e Click **OK** or **Print**.

For Macintosh users:

- a With a document open, click **File > Print**.
- b From the Copies & Pages or General pop-up menu, choose **Manual Paper**.
- c Click **OK** or **Print**.

2 When **Load Manual <type> <size>** appears, load the paper facedown into the manual feeder. Load envelopes with the flap side up.

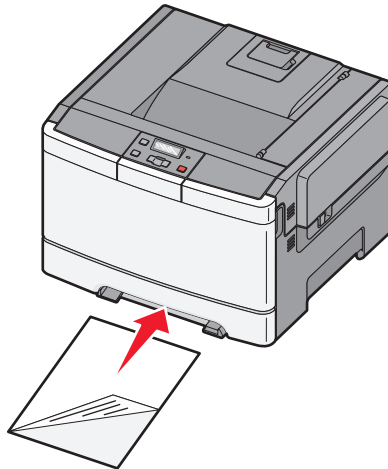

Notes:

- Align the long edge of the paper so that it is flush with the right side of the manual feeder.
- To achieve the best possible print quality, use only high-quality paper designed for laser printers.

- 3 Move the width guide until it lightly touches the sheet. Do not force the width guide against the paper, or it could be damaged.

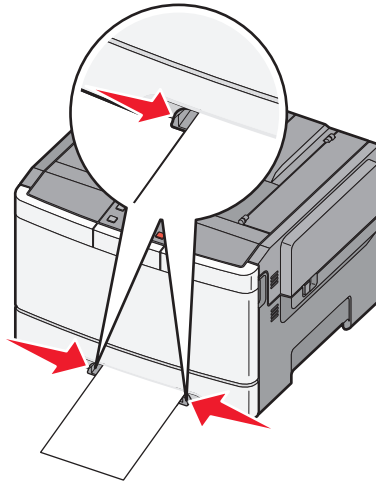

- 4 Push the paper in until it stops. The printer pulls it in farther.
- 5 From the printer control panel, set the Paper Size and Paper Type.

Paper and specialty media guide

Additional information for printing on speciality medias may be found in the *Cardstock and Label Guide* available on Lexmark.com/publications.

Paper guidelines

Paper characteristics

The following paper characteristics affect print quality and reliability. Consider these characteristics when evaluating new paper stock.

Weight

The printer can automatically feed paper weights from 60 to 176 g/m² (16 to 47 lb bond) grain long. Paper lighter than 75 g/m² (20 lb) might not be stiff enough to feed properly, causing jams. For best performance, use 80 g/m² (21 lb bond) grain long paper. For paper smaller than 182 x 257 mm (7.2 x 10.1 in.), we recommend 90 g/m² or heavier paper.

Curl

Curl is the tendency for paper to curl at its edges. Excessive curl can cause paper feeding problems. Curl can occur after the paper passes through the printer, where it is exposed to high temperatures. Storing paper unwrapped in hot, humid, cold, or dry conditions, even in the trays, can contribute to paper curling prior to printing and can cause feeding problems.

Smoothness

Paper smoothness directly affects print quality. If paper is too rough, toner cannot fuse to it properly. If paper is too smooth, it can cause paper feeding or print quality issues. Always use paper between 100 and 300 Sheffield points; however, smoothness between 150 and 200 Sheffield points produces the best print quality.

Moisture content

The amount of moisture in paper affects both print quality and the ability of the printer to feed the paper correctly. Leave paper in its original wrapper until it is time to use it. This limits the exposure of paper to moisture changes that can degrade its performance.

Condition paper before printing by storing it in its original wrapper in the same environment as the printer for 24 to 48 hours before printing. Extend the time several days if the storage or transportation environment is very different from the printer environment. Thick paper may also require a longer conditioning period.

Grain direction

Grain refers to the alignment of the paper fibers in a sheet of paper. Grain is either *grain long*, running the length of the paper, or *grain short*, running the width of the paper.

For 60 to 176 g/m² (16 to 47 lb bond) paper, use grain long fibers.

Fiber content

Most high-quality xerographic paper is made from 100% chemically treated pulped wood. This content provides the paper with a high degree of stability resulting in fewer paper feeding problems and better print quality. Paper containing fibers such as cotton possesses characteristics that can negatively affect paper handling.

Unacceptable paper

The following paper types are not recommended for use with the printer:

- Chemically treated papers used to make copies without carbon paper, also known as carbonless papers, carbonless copy paper (CCP), or no carbon required (NCR) paper
- Preprinted papers with chemicals that may contaminate the printer
- Preprinted papers that can be affected by the temperature in the printer fuser
- Preprinted papers that require a registration (the precise print location on the page) greater than ± 2.3 mm (± 0.9 in.), such as optical character recognition (OCR) forms

In some cases, registration can be adjusted with a software application to successfully print on these forms.

- Coated papers (erasable bond), synthetic papers, thermal papers
- Rough-edged, rough or heavily textured surface papers, or curled papers
- Recycled papers that fail EN12281:2002 (European)
- Paper weighing less than 60 g/m^2 (16 lb)
- Multiple-part forms or documents

Selecting paper

Using appropriate paper prevents jams and helps ensure trouble-free printing.

To help avoid jams and poor print quality:

- *Always* use new, undamaged paper.
- Before loading paper, know the recommended print side of the paper. This information is usually indicated on the paper package.
- *Do not* use paper that has been cut or trimmed by hand.
- *Do not* mix paper sizes, types, or weights in the same source; mixing results in jams.
- *Do not* use coated papers unless they are specifically designed for electrophotographic printing.

Selecting preprinted forms and letterhead

Use these guidelines when selecting preprinted forms and letterhead:

- Use grain long for 60 to 176 g/m^2 weight paper.
- Use only forms and letterhead printed using an offset lithographic or engraved printing process.
- Avoid papers with rough or heavily textured surfaces.

Use papers printed with heat-resistant inks designed for use in xerographic copiers. The ink must be able to withstand temperatures up to 200°C (392°F) without melting or releasing hazardous emissions. Use inks that are not affected by the resin in toner. Inks that are oxidation-set or oil-based generally meet these requirements; latex inks might not. When in doubt, contact the paper supplier.

Preprinted papers such as letterhead must be able to withstand temperatures up to 200°C (392°F) without melting or releasing hazardous emissions.

Storing paper

Use these paper storage guidelines to help avoid jams and uneven print quality:

- For best results, store paper where the temperature is 21°C (70°F) and the relative humidity is 40%. Most label manufacturers recommend printing in a temperature range of 18 to 24°C (65 to 75°F) with relative humidity between 40 and 60%.
- Store paper in cartons when possible, on a pallet or shelf, rather than on the floor.
- Store individual packages on a flat surface.
- Do not store anything on top of individual paper packages.

Supported paper sizes, types, and weights

The following tables provide information on standard and optional paper sources and the types of paper they support.

Note: For an unlisted paper size, select the closest *larger* listed size.

Paper sizes supported by the printer

Paper size	Dimensions	250-sheet tray (standard)	550-sheet tray (optional)	Optional multipurpose feeder	Manual feeder	Duplex	Standard exit tray
A4	210 x 297 mm (8.3 x 11.7 in.)	✓	✓	✓	✓	✓	✓
A5	148 x 210 mm (5.83 x 8.3 in.)	✓	✓	✓	✓	X	✓
JIS B5	182 x 257 mm (7.2 x 10.1 in.)	✓	✓	✓	✓	X	✓
A6	105 x 148 mm (4.1 x 5.8 in.)	X	X	✓	✓	X	✓
Statement	140 x 216 mm (5.5 x 8.5 in.)	X	X	✓	✓	X	✓
Letter	216 x 279 mm (8.5 x 11 in.)	✓	✓	✓	✓	✓	✓
Folio	216 x 330 mm (8.5 x 13 in.)	✓	✓	✓	✓	✓	✓
Oficio (Mexico)	216 x 340 mm (8.5 x 13 in.)	✓	✓	✓	✓	✓	✓
Legal	216 x 356 mm (8.5 x 14 in.)	✓	✓	✓	✓	✓	✓
Executive	184 x 267 mm (7.3 x 10.5 in.)	✓	✓	✓	✓	X	✓

* When Universal is selected, the page is formatted for 216 x 356 mm (8.5 x 14 in.) unless the size is specified by the software program.

Paper size	Dimensions	250-sheet tray (standard)	550-sheet tray (optional)	Optional multipurpose feeder	Manual feeder	Duplex	Standard exit tray
Universal*	148 x 210 mm (5.8 x 8.3 in.) up to 216 x 356 mm (8.5 x 14 in.)	✓	✓	✓	✓	X	✓
	76 x 127 mm (3 x 5 in.) up to 216 x 356 mm (8.5 x 14 in.)	X	X	✓	✓	X	✓
	210 x 279 mm (8.3 x 11 in.) up to 216 x 356 mm (8.5 x 14 in.)	✓	✓	✓	✓	✓	✓
7 3/4 Envelope (Monarch)	98 x 191 mm (3.9 x 7.5 in.)	X	X	✓	✓	X	✓
9 Envelope	98 x 225 mm (3.9 x 8.9 in.)	X	X	✓	✓	X	✓
10 Envelope	105 x 241 mm (4.1 x 9.5 in.)	X	X	✓	✓	X	✓
DL Envelope	110 x 220 mm (4.3 x 8.7 in.)	X	X	✓	✓	X	✓
B5 Envelope	176 x 250 mm (6.9 x 9.8 in.)	X	X	✓	✓	X	✓
C5 Envelope	162 x 229 mm (6.4 x 9 in.)	X	X	✓	✓	X	✓
Monarch	105 x 241 mm (4.1 x 9.5 in.)	X	X	✓	✓	X	✓
Other Envelope	98 x 162 mm (3.9 x 6.3 in.) up to 176 x 250 mm (6.9 x 9.8 in.)	X	X	✓	✓	X	✓

* When Universal is selected, the page is formatted for 216 x 356 mm (8.5 x 14 in.) unless the size is specified by the software program.

Paper types supported by the printer

Paper type	Standard 250-sheet tray (Tray 1)	Optional 550-sheet tray (Tray 2)	Optional multipurpose feeder	Manual feeder	Duplex	Standard exit bin
Paper	✓	✓	✓	✓	✓	✓
Card stock	✓	✓	✓	✓	X	✓
Transparencies*	✓	X	✓	✓	X	✓
Envelopes	X	X	✓	✓	X	✓
Paper labels	✓	✓	✓	✓	X	✓

* Lexmark transparency part numbers 12A8240 and 12A8241 are supported from the standard tray, manual feeder, and the optional multipurpose feeder.

Paper types and weights supported by the printer

Paper type	Standard 250-sheet tray (Tray 1)	Optional 550-sheet tray (Tray 2)	Optional multipurpose feeder	Manual feeder
Light ^{1,2}	60 to 74.9 g/m ² grain long (16 to 19.9 lb bond)	60 to 74.9 g/m ² grain long (16 to 19.9 lb bond)	60 to 74.9 g/m ² grain long (16 to 19.9 lb bond)	60 to 74.9 g/m ² grain long (16 to 19.9 lb bond)
Plain ^{1,2}	75 to 89.9 g/m ² grain long (20 to 23.8 lb bond)	75 to 89.9 g/m ² grain long (20 to 23.8 lb bond)	75 to 89.9 g/m ² grain long (20 to 23.8 lb bond)	75 to 89.9 g/m ² grain long (20 to 23.8 lb bond)
Heavy ^{1,2}	90 to 104.9 g/m ² grain long (23.9 to 27.8 lb bond)	90 to 104.9 g/m ² grain long (23.9 to 27.8 lb bond)	90 to 104.9 g/m ² grain long (23.9 to 27.8 lb bond)	90 to 104.9 g/m ² grain long (23.9 to 27.8 lb bond)
Cardstock ^{1,2}	105 to 176 g/m ² grain long (27.8 to 47 lb bond)	105 to 176 g/m ² grain long (27.8 to 47 lb bond)	105 to 176 g/m ² grain long (27.8 to 47 lb bond)	105 to 176 g/m ² grain long (27.8 to 47 lb bond)

¹ Paper types must be set to match the supporting paper weights.

² The duplex supports paper weights between 60–105 g/m² (16–28 lb) grain long bond. The duplex does not support card stock, transparencies, envelopes, and labels.

³ For 60 to 176 g/m² (16 to 47 lb bond) paper, we recommend grain long fibers.

⁴ Lexmark transparency part numbers 12A8240 and 12A8241 are supported from the standard tray, manual feeder, and the optional multipurpose feeder.

⁵ The pressure sensitive area must enter the printer first.

⁶ 100 percent cotton content maximum weight is 90 g/m² (24 lb) bond.

⁷ 105 g/m² (28 lb) bond envelopes are limited to 25 percent cotton content.

Paper type	Standard 250-sheet tray (Tray 1)	Optional 550-sheet tray (Tray 2)	Optional multipurpose feeder	Manual feeder
Glossy papers	Book —88 to 176 g/m ² grain long (60 to 120 lb book) Cover —162 to 176 g/m ² grain long (60 to 65 lb cover)	Book —88 to 176 g/m ² grain long (60 to 120 lb book) Cover —162 to 176 g/m ² grain long (60 to 65 lb cover)	Book —88 to 176 g/m ² grain long (60 to 120 lb book) Cover —162 to 176 g/m ² grain long (60 to 65 lb cover)	Book —88 to 176 g/m ² grain long (60 to 120 lb book) Cover —162 to 176 g/m ² grain long (60 to 65 lb cover)
Card stock—maximum (grain long) ³	Index Bristol —120 g/m ² (67 lb) Tag —120 g/m ² (74 lb) Cover —135 g/m ² (50 lb)	Index Bristol —120 g/m ² (67 lb) Tag —120 g/m ² (74 lb) Cover —135 g/m ² (50 lb)	Index Bristol —120 g/m ² (67 lb) Tag —120 g/m ² (74 lb) Cover —135 g/m ² (50 lb)	Index Bristol —120 g/m ² (67 lb) Tag —120 g/m ² (74 lb) Cover —135 g/m ² (50 lb)
Card stock—maximum (grain short) ¹	Index Bristol —163 g/m ² (90 lb) Tag —163 g/m ² (100 lb) Cover —176 g/m ² (65 lb)	Index Bristol —163 g/m ² (90 lb) Tag —163 g/m ² (100 lb) Cover —176 g/m ² (65 lb)	Index Bristol —163 g/m ² (90 lb) Tag —163 g/m ² (100 lb) Cover —176 g/m ² (65 lb)	Index Bristol —163 g/m ² (90 lb) Tag —163 g/m ² (100 lb) Cover —176 g/m ² (65 lb)
Transparencies ⁴	170–180 g/m ² (45 to 48 lb)	N/A	170–180 g/m ² (45 to 48 lb)	170–180 g/m ² (45 to 48 lb)
Labels—maximum ⁵	Paper —131 g/m ² (35 lb bond)	Paper —131 g/m ² (35 lb bond)	Paper —131 g/m ² (35 lb bond)	Paper —131 g/m ² (35 lb bond)
Envelopes ^{6,7}	X	X	60 to 105 g/m ² (16 to 28 lb bond)	60 to 105 g/m ² (16 to 28 lb bond)

¹ Paper types must be set to match the supporting paper weights.

² The duplex supports paper weights between 60–105 g/m² (16–28 lb) grain long bond. The duplex does not support card stock, transparencies, envelopes, and labels.

³ For 60 to 176 g/m² (16 to 47 lb bond) paper, we recommend grain long fibers.

⁴ Lexmark transparency part numbers 12A8240 and 12A8241 are supported from the standard tray, manual feeder, and the optional multipurpose feeder.

⁵ The pressure sensitive area must enter the printer first.

⁶ 100 percent cotton content maximum weight is 90 g/m² (24 lb) bond.

⁷ 105 g/m² (28 lb) bond envelopes are limited to 25 percent cotton content.

Paper capacities

Input capacities

Paper type	Standard 250-sheet tray (Tray 1)	Optional 550-sheet tray (Tray 2)	Optional multipurpose tray
Paper	250 sheets ¹	550 sheets ¹	100 sheets ¹
Labels	100 ²	200 ²	50 ²
Transparencies	50	X	50
Envelopes	X	X	10
Other	X	X	Various quantities ³

¹ Based on 75 g/m² (20 lb) paper
²Capacity varies depending on label material and construction.
³Capacity varies depending on the weight and type of media.

Output capacity

Paper type	Standard 100-sheet output bin ²
Paper	100 sheets ¹

¹ Based on 75 g/m² (20 lb) paper
² Capacity may vary depending on media specifications and the printer operating environment.

Using recycled paper and other office papers

As an environmentally conscious company, Lexmark supports the use of recycled office paper produced specifically for use in laser (electrophotographic) printers. In 1998, Lexmark presented to the US government a study demonstrating that recycled paper produced by major mills in the US fed as well as non-recycled paper. However, no blanket statement can be made that *all* recycled paper will feed well.

Lexmark consistently tests its printers with recycled paper (20–100% post-consumer waste) and a variety of test paper from around the world, using chamber tests for different temperature and humidity conditions. Lexmark has found no reason to discourage the use of today's recycled office papers, but generally the following property guidelines apply to recycled paper.

- Low moisture content (4–5%)
- Suitable smoothness (100–200 Sheffield units, or 140–350 Bendtsen units, European)

Note: Some much smoother papers (such as premium 24 lb laser papers, 50–90 Sheffield units) and much rougher papers (such as premium cotton papers, 200–300 Sheffield units) have been engineered to work very well in laser printers, despite surface texture. Before using these types of paper, consult your paper supplier.

- Suitable sheet-to-sheet coefficient of friction (0.4–0.6)
- Sufficient bending resistance in the direction of feed

Recycled paper, paper of lower weight (<60 g/m² [16 lb bond]) and/or lower caliper (<3.8 mils [0.1 mm]), and paper that is cut grain-short for portrait (or short-edge) fed printers may have lower bending resistance than is required for reliable paper feeding. Before using these types of paper for laser (electrophotographic) printing, consult your paper supplier. Remember that these are general guidelines only and that paper meeting these guidelines may still cause paper feeding problems in any laser printer (for example, if the paper curls excessively under normal printing conditions).

Printing

This chapter covers printing, printer reports, and job cancellation. Selection and handling of paper and specialty media can affect how reliably documents print. For more information, see "Avoiding jams" and "Storing paper."

Printing a document

- 1 Load paper into a tray or feeder.
- 2 From the printer control panel Paper menu, set the Paper Type and Paper Size to match the loaded paper.
- 3 Do one of the following:

For Windows users

- a With a document open, click **File** → **Print**.
- b Click **Properties**, **Preferences**, **Options**, or **Setup**, and then adjust the settings as needed.

Note: To print on a specific size or type of paper, adjust the paper size or type settings to match the loaded paper, or select the appropriate tray or feeder.

- c Click **OK**, and then click **Print**.

For Macintosh users

- a Customize the settings as needed in the Page Setup dialog:
 - 1 With a document open, choose **File** > **Page Setup**.
 - 2 Choose a paper size or create a custom size to match the loaded paper.
 - 3 Click **OK**.

- b Customize the settings as needed in the Print dialog:
 - 1 With a document open, choose **File** > **Print**.
If necessary, click the disclosure triangle to see more options.
 - 2 From the Print dialog and pop-up menus, adjust the settings as needed.

Note: To print on a specific paper type, adjust the paper type setting to match the loaded paper, or select the appropriate tray or feeder.

- 3 Click **Print**.

Warning—Potential Damage: While printing, do not touch the metal shaft in the area where the printer ejects paper into the standard exit bin.

Printing specialty documents

Additional information for printing on speciality medias may be found in the *Cardstock and Label Guide* available on Lexmark.com/publications.

Tips on using letterhead

Page orientation is important when printing on letterhead. Use the following table to determine which direction to load the letterhead:

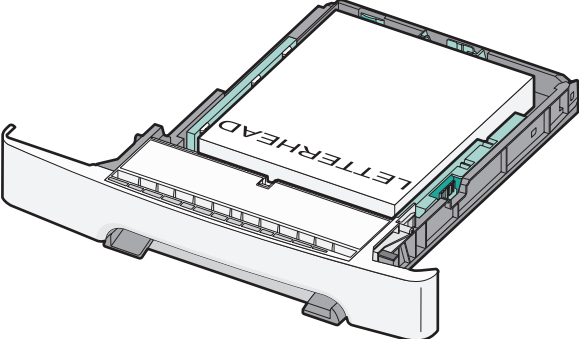
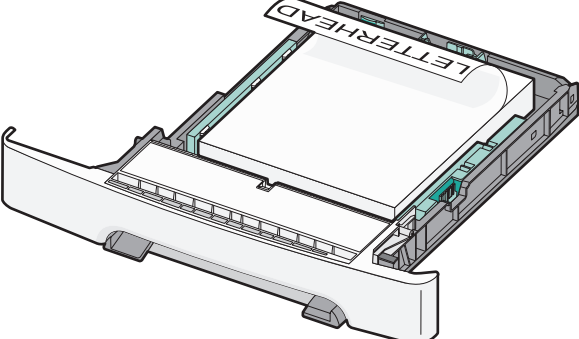
Source or process	Print side and paper orientation
<ul style="list-style-type: none">• Standard 250-sheet tray• Optional 550-sheet tray• Simplex (one-sided) printing from trays	<p>Printed letterhead design is placed faceup. The top edge of the sheet with the logo is placed at the front of the tray.</p> 
<p>Duplex (two-sided) printing from trays</p>	<p>Printed letterhead design is placed facedown. The top edge of the sheet with the logo is placed at the back of the tray.</p> 
<p>Note: Check with the manufacturer or vendor to determine whether the chosen preprinted letterhead is acceptable for laser printers.</p>	

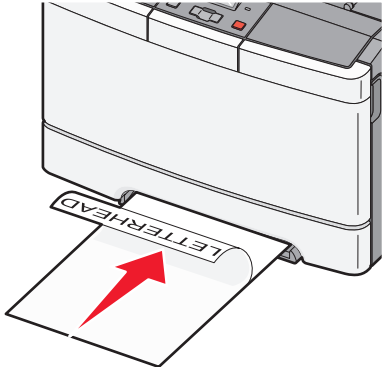
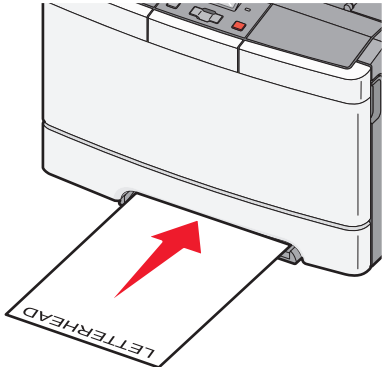
Source or process	Print side and paper orientation
Manual feeder (simplex printing) Multipurpose feeder	<p>Preprinted letterhead design is placed facedown. The top edge of the sheet with the logo should enter the manual feeder first.</p> 
Manual feeder (duplex printing) Multipurpose feeder	<p>Preprinted letterhead design is placed faceup. The top edge of the sheet with the logo should enter the manual feeder last.</p> 
<p>Note: Check with the manufacturer or vendor to determine whether the chosen preprinted letterhead is acceptable for laser printers.</p>	

Tips on using transparencies

Print samples on the transparencies being considered for use before buying large quantities.

When printing on transparencies:

- Feed transparencies from the 250-sheet tray, manual feeder, or optional multipurpose feeder.
- Use transparencies designed specifically for laser printers. Check with the manufacturer or vendor to ensure transparencies are able to withstand temperatures up to 200°C (392°F) without melting, discoloring, offsetting, or releasing hazardous emissions.
- To prevent print quality problems, avoid getting fingerprints on the transparencies.
- Before loading transparencies, fan the stack to prevent sheets from sticking together.
- We recommend Lexmark part number 12A8240 for letter-size transparencies and Lexmark part number 12A8241 for A4-size transparencies.

Tips on using envelopes

Print samples on the envelopes being considered for use before buying large quantities.

When printing on envelopes:

- Feed envelopes from the manual feeder or optional multipurpose feeder.
- Set the Paper Type to Envelope, and select the envelope size.
- Use envelopes designed specifically for laser printers. Check with the manufacturer or vendor to ensure the envelopes can withstand temperatures up to 200°C (392°F) without sealing, wrinkling, curling excessively, or releasing hazardous emissions.
- For the best performance, use envelopes made from 60 g/m² (16 lb bond) paper. Use up to 105 g/m² (28 lb bond) weight for envelopes as long as the cotton content is 25% or less. All-cotton envelopes must not exceed 90 g/m² (24 lb bond) weight.
- Use only new envelopes.
- To optimize performance and minimize jams, do not use envelopes that:
 - Have excessive curl or twist
 - Are stuck together or damaged in any way
 - Have windows, holes, perforations, cutouts, or embossing
 - Have metal clasps, string ties, or folding bars
 - Have an interlocking design
 - Have postage stamps attached
 - Have any exposed adhesive when the flap is in the sealed or closed position
 - Have bent corners
 - Have rough, cockle, or laid finishes
- Adjust the width guides to fit the width of the envelopes.

Note: A combination of high humidity (over 60%) and the high printing temperature may wrinkle or seal envelopes.

Tips on using paper labels

Print samples on the labels being considered for use before buying large quantities.

Note: Use only paper label sheets.

When printing on labels:

- From MarkVision Professional, the printer software, or the printer control panel, set the Paper Type to Labels.
- Use only letter-, A4-, or legal-size label sheets.
- Use labels designed specifically for laser printers. Check with the manufacturer or vendor to verify that:
 - The labels can withstand temperatures up to 200°C (392°F) without sealing, excessive curling, wrinkling, or releasing hazardous emissions.
 - Label adhesives, face sheet (printable stock), and topcoats can withstand up to 25 psi (172 kPa) pressure without delaminating, oozing around the edges, or releasing hazardous fumes.
- Do not use labels with slick backing material.
- Use full label sheets. Partial sheets may cause labels to peel off during printing, resulting in a jam. Partial sheets also contaminate the printer and the cartridge with adhesive, and could void the printer and cartridge warranties.
- Do not use labels with exposed adhesive.
- Do not print within 1 mm (0.04 in.) of the edge of the label, of the perforations, or between die-cuts of the label.

- Be sure adhesive backing does not reach to the sheet edge. Zone coating of the adhesive at least 1 mm (0.04 in.) away from edges is recommended. Adhesive material contaminates the printer and could void the warranty.
- If zone coating of the adhesive is not possible, remove a 1.6 mm (0.06 in.) strip on the leading and driver edge, and use a non-oozing adhesive.
- Portrait orientation works best, especially when printing bar codes.

Tips on using card stock

Card stock is heavy, single-ply specialty media. Many of its variable characteristics, such as moisture content, thickness, and texture, can significantly impact print quality. Print samples on the card stock being considered for use before buying large quantities.

When printing on card stock:

- From MarkVision Professional, the printer software, or the printer control panel:
 - 1** Set the Paper Type to Card Stock.
 - 2** Set the Paper Weight to Card Stock Weight.
 - 3** Set the Card Stock Weight to Normal or Heavy.
- Be aware that preprinting, perforation, and creasing may significantly affect the print quality and cause jams or other paper handling problems.
- Check with the manufacturer or vendor to ensure the card stock can withstand temperatures up to 200°C (392°F) without releasing hazardous emissions.
- Do not use preprinted card stock manufactured with chemicals that may contaminate the printer. Preprinting introduces semi-liquid and volatile components into the printer.
- Use grain short card stock when possible.

Printing from a flash drive

A USB port is located on the printer control panel of some models. Insert a flash drive to print supported file types. Supported file types include: .pdf, .gif, .jpeg, .jpg, .bmp, .png, .tiff, .tif, .pcx, and .dcx.

Many flash drives are tested and approved for use with the printer. For more information, visit the Lexmark Web site at www.lexmark.com.

Notes:

- Hi-Speed USB devices must support the Full-speed standard. Devices only supporting USB Low-speed capabilities are not supported.
- USB devices must support the FAT (*File Allocation Tables*) system. Devices formatted with NTFS (*New Technology File System*) or any other file system are not supported.
- Before printing an encrypted .pdf file, enter the file password from the printer control panel.
- You cannot print files for which you do not have printing permissions.

To print from a flash drive:

- 1 Make sure the printer is on and **Ready** or **Busy** appears.
- 2 Insert a flash drive into the USB port.

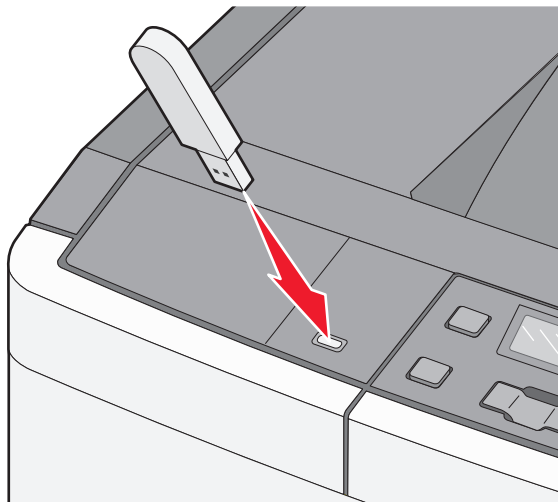





Notes:

- If you insert the flash drive when the printer requires attention, such as when a jam has occurred, the printer ignores the memory device.
 - If you insert the flash drive while the printer is printing other jobs, **Busy** appears.
- 3 Press the arrow buttons until the document you want to print appears, and then press .
- Note:** Folders found on the flash drive appear as folders. File names are appended by the extension type (for example, .jpg).
- 4 Press to print one copy, or enter the number of copies using the arrow buttons, and then press to initiate the print job.
- Note:** Do not remove the flash drive from the USB port until the document has finished printing.

Printing information pages



Printing a font sample list

To print samples of the fonts currently available for your printer:

- 1 Make sure the printer is on and **Ready** appears.
 - 2 From the printer control panel, press .
 - 3 Press the arrow buttons until **Reports** appears, and then press .
 - 4 Press the arrow buttons until **Print Fonts** appears, and then press .
 - 5 Press the arrow buttons until **PCL Fonts, PostScript Fonts, or PPDS Fonts** appears, and then press .
- After the font sample list prints, **Ready** appears.



Printing a directory list

A directory list shows the resources stored in flash memory or on the hard disk.



- 1 Make sure the printer is on and **Ready** appears.
 - 2 From the printer control panel, press .
 - 3 Press the arrow buttons until **Reports** appears, and then press .
- After the directory list prints, **Ready** appears.

Printing the print quality test pages

Print the print quality test pages to isolate print quality problems.

- 1 Turn the printer off.
 - 2 Hold down  and the right arrow button while turning the printer on.
 - 3 Release the buttons when the dots appear, and wait for **CONFIG MENU** to appear.
 - 4 Press the arrow buttons until **PRINT_QUAL_TXT** appears, and then press .
- The print quality test pages print.
- 5 Press the arrow buttons until **Exit Config Menu** appears, and then press .
- Resetting the Printer** appears briefly, and then **Ready** appears.

Canceling a print job from the printer control panel

- 1 Press .
- Stopped** appears.
- 2 Press .

Canceling a print job from the computer

To cancel a print job, do one of the following:

For Windows users

In Windows Vista:

- 1 Click .
- 2 Click **Control Panel**.
- 3 Click **Hardware and Sound**.
- 4 Click **Printers**.
- 5 Double-click the printer icon.
- 6 Select the job to cancel.
- 7 From the keyboard, press **Delete**.

In Windows XP:

- 1 Click **Start**.
- 2 From **Printers and Faxes**, double-click the printer icon.
- 3 Select the job to cancel.
- 4 From the keyboard, press **Delete**.

From the Windows taskbar:

When you send a job to print, a small printer icon appears in the right corner of the taskbar.

- 1 Double-click the printer icon.
A list of print jobs appears in the printer window.
- 2 Select a job to cancel.
- 3 From the keyboard, press **Delete**.

For Macintosh users

In Mac OS X version 10.5:

- 1 From the Apple menu, choose **System Preferences**.
- 2 Click **Print & Fax**, and then double-click the printer icon.
- 3 From the printer window, select the job to cancel.
- 4 From the icon bar at the top of the window, click the **Delete** icon.

In Mac OS X version 10.4 and earlier:

- 1 From the Go menu, choose **Applications**.
- 2 Double-click **Utilities**, and then double-click **Print Center** or **Printer Setup Utility**.
- 3 Double-click the printer icon.

- 4 From the printer window, select the job to cancel.
- 5 From the icon bar at the top of the window, click the **Delete** icon.

Clearing jams

Avoiding jams

The following hints can help you avoid jams.

Paper tray recommendations

- Make sure the paper lies flat in the tray.
- Do not remove trays while the printer is printing.
- Do not load trays, the multipurpose feeder, or the envelope feeder while the printer is printing. Load them prior to printing, or wait for a prompt to load them.
- Do not load too much paper. Make sure the stack height does not exceed the indicated maximum height.
- Make sure the guides in the paper trays, multipurpose feeder, or envelope feeder are properly positioned and are not pressing too tightly against the paper or envelopes.
- Push all trays in firmly after loading paper.

Paper recommendations

- Use only recommended paper or specialty media. For more information, see “Paper types and weights supported by the printer” on page 50.
- Do not load wrinkled, creased, damp, bent, or curled paper.
- Flex, fan, and straighten paper before loading it.
- Do not use paper that has been cut or trimmed by hand.
- Do not mix paper sizes, weights, or types in the same stack.
- Make sure all sizes and types are set correctly in the printer control panel menus.
- Store paper per the manufacturer's recommendations.

Envelope recommendations

- To reduce wrinkling, use the Envelope Enhance menu in the Paper menu.
- Do not feed envelopes that:
 - Have excessive curl or twist
 - Have windows, holes, perforations, cutouts, or embossing
 - Have metal clasps, string ties, or folding bars
 - Have an interlocking design
 - Have postage stamps attached
 - Have any exposed adhesive when the flap is in the sealed or closed position
 - Have bent corners
 - Have rough, cockle, or laid finishes
 - Are stuck together or damaged in any way

Understanding jam numbers and locations

When a jam occurs, a message indicating the jam location appears. The following illustration and table list the paper jams that can occur and the location of each jam. Open doors and covers, and remove trays to access jam locations.

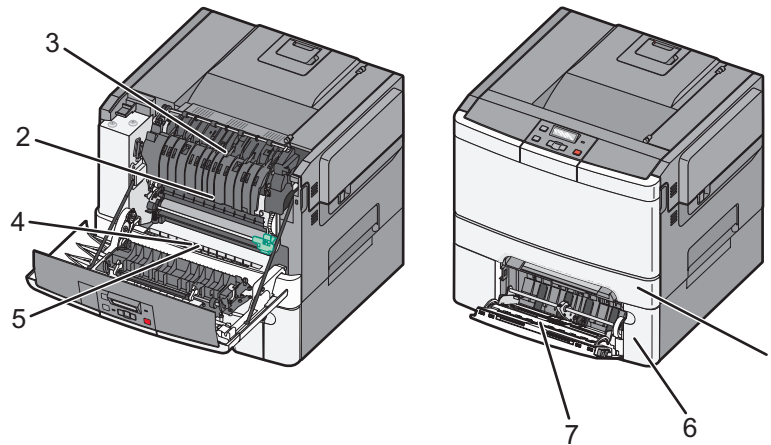

	Jam number	Jam location	Instructions
1	200	Standard 250-sheet tray and manual feeder (Tray 1)	1 Open the front door. Inspect the area behind the front door, and then remove any jams. 2 Open the fuser cover. Inspect the area under the cover, and then remove any jams. 3 Close the front door. 4 Pull Tray 1 out. Inspect the tray area, and then remove any jams. 5 Verify that the paper is loaded correctly. 6 Reinsert Tray 1.
2	201	Under the fuser	
3	202	In the fuser	
4	230	In the duplex	
5	235	In the duplex Note: This jam number indicates that the paper being used for a duplex print job is not supported.	
6	242	550-sheet tray (Tray 2)	Pull Tray 1 out. Inspect the tray area, and then remove any jams.
7	250	In the multipurpose feeder	1 Inspect the multipurpose feeder, and then remove any jams 2 Reinsert Tray 1.

200 paper jam

- 1 Grasp the handle, and pull the standard 250-sheet tray (Tray 1) and manual feeder out.

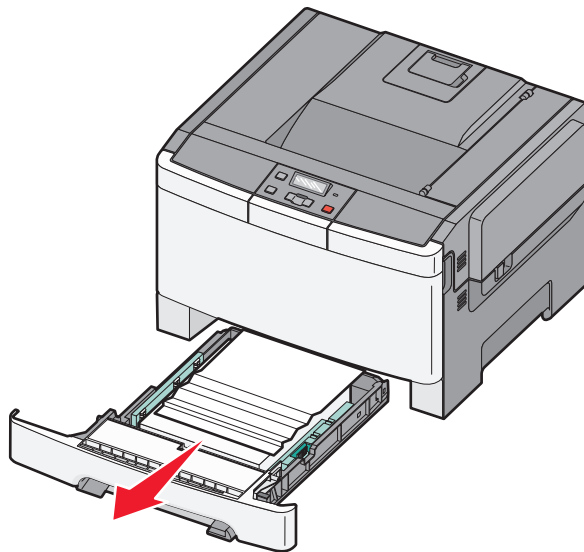

- 2 Remove the jam.

Note: Make sure all paper fragments are removed.

- 3 Insert the tray.

- 4 Press .

201 paper jam

- 1 Grasp the front door at the side handholds, and then pull it toward you to open it.

 **CAUTION—HOT SURFACE:** The inside of the printer might be hot. To reduce the risk of injury from a hot component, allow the surface to cool before touching.

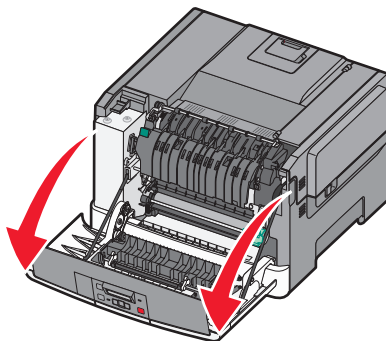

- 2 Remove the jammed paper.

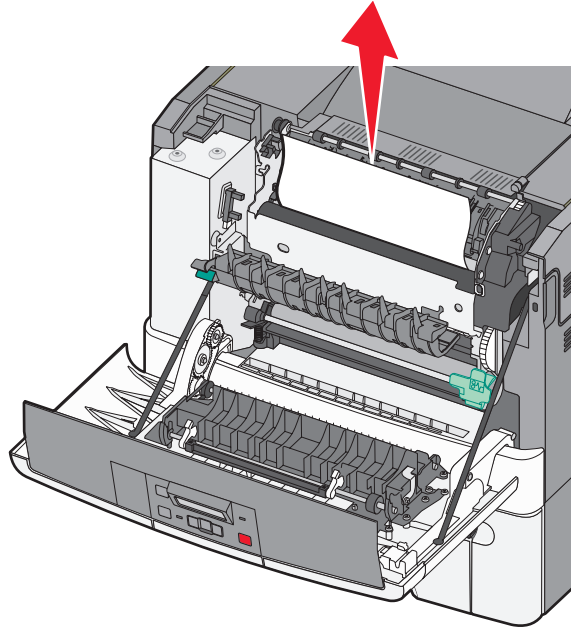

Note: Make sure all paper fragments are removed.

- 3 Close the front door.
- 4 Press .

202 paper jam

- 1 Grasp the front door at the side handholds, and then pull it toward you to open it.

 **CAUTION—HOT SURFACE:** The inside of the printer might be hot. To reduce the risk of injury from a hot component, allow the surface to cool before touching.

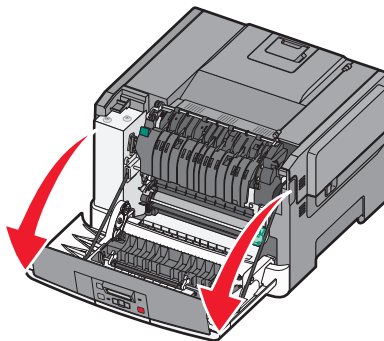

- 2 Grasp the green lever, and then pull the fuser cover toward you.
- 3 Hold the fuser cover down, and then remove the jammed paper.

The fuser cover closes when released.

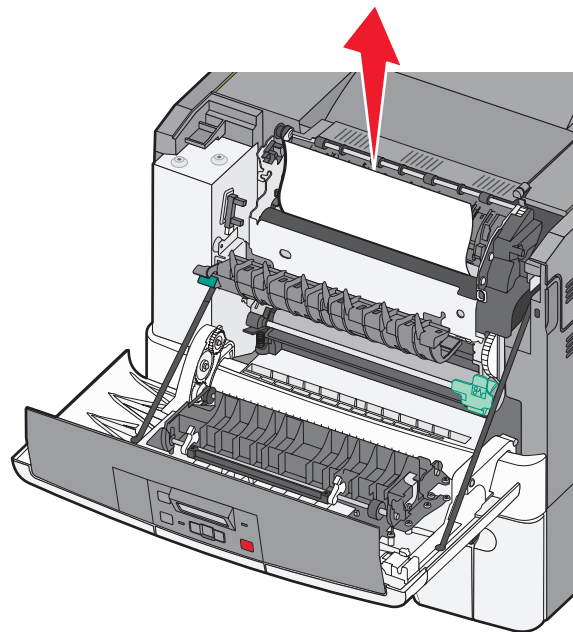
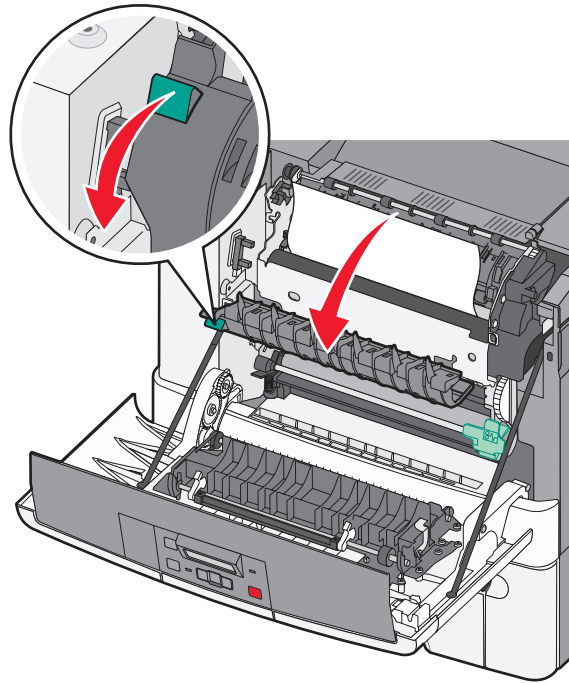

Note: Make sure all paper fragments are removed.

4 Close the front door.

5 Press .

230 paper jam

- 1 Grasp the front door at the side handholds, and then pull it toward you to open it.
- 2 Remove the jam.
- 3 Press .

235 paper jam

- 1 Grasp the front door at the side handholds, and then pull it toward you to open it.
- 2 Remove the jam.
- 3 Load the tray with the correct paper size.
- 4 Insert the tray.
- 5 Close the front door.
- 6 Press .

242 paper jam

- 1 Grasp the handle, and pull the optional 650-sheet duo drawer out.

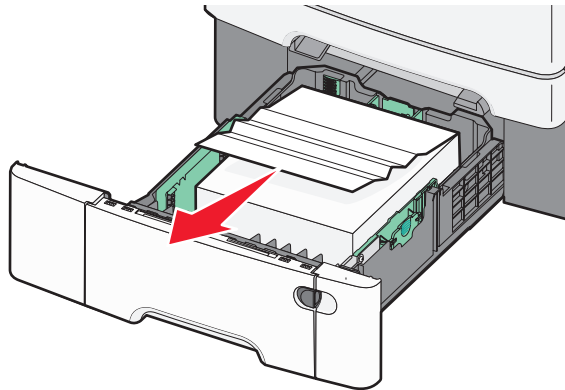

- 2 If a paper jam is in the multipurpose feeder, push the lever.
- 3 Remove the jam.
Note: Make sure all paper fragments are removed.
- 4 Insert the tray.
- 5 Press .

250 paper jam

- 1 Push the lever in the multipurpose feeder to access the paper jammed.

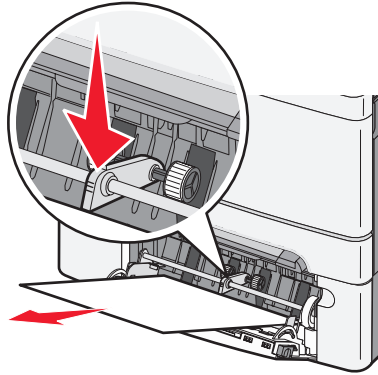

- 2 Remove the jam.

Note: Make sure all paper fragments are removed.

- 3 Insert the tray.

- 4 Press .

Understanding printer menus

Menu list

	Menu
✓	Supplies Menu Paper Menu Reports Settings Network/Ports

A number of menus are available to make it easy for you to change printer settings:

Note: Certain menus are not available on selected printer models.

Supplies Menu

- Cyan Cartridge
- Magenta Cartridge
- Yellow Cartridge
- Black Cartridge
- Imaging Kit
- Waste Toner Bottle

Paper Menu

- Default Source
- Size/Type
- Paper Texture
- Paper Weight
- Paper Loading
- Custom Type
- Universal Setup

Reports

- Menu Settings Page
- Device Statistics
- Network Setup Page
- Profiles List
- Print Fonts
- Print Directory
- Print Defects
- Print Demo
- Asset Report

Settings

- General Settings
- Setup Menu
- Finishing Menu
- Quality Menu
- Utilities Menu
- PDF Menu
- PostScript Menu
- PCL Emul Menu
- Image Menu
- PictBridge Menu
- Flash Drive Menu

Network/Ports

- Active NIC
- Network Menu
- Wireless Menu
- USB Menu

Supplies menu

Menu item	Description
Cyan, Magenta, Yellow, or Black Toner Cartridges Early Warning Low Invalid Replace Missing or Defective OK Unsupported	Shows the status of the toner cartridges Note: Replace Cartridge indicates the cartridge is nearly empty, and print quality problems may result.
Imaging Kit OK Replace Black Imaging Kit Replace Black and Color Imaging Kit Defective	Shows the status of the imaging kit
Waste Toner Bottle Near Full Replace Missing OK	Shows the status of the waste toner bottle

Paper menu

Default Source menu

Menu item	Description
Default Source Tray <x> MP Feeder Manual Paper Manual Env	Sets a default paper source for all print jobs Notes: <ul style="list-style-type: none"> • The 650-sheet-duo drawer must be installed in order for MP Feeder or Tray 2 to appear as a menu setting in the Paper Menu. • Tray 1 (standard tray) is the factory default setting. • Only an installed paper source will appear as a menu setting. • A paper source selected by a print job will override the Default Source setting for the duration of the print job. • If the same size and type of paper are in two trays and the Paper Size and Paper Type settings match, the trays are automatically linked. When one tray is empty, the job prints using the linked tray.

Paper Size/Type menu

Menu item	Description
<p>Tray <x> Size</p> <ul style="list-style-type: none"> A4 A5 JIS B5 Letter Folio Oficio (Mexico) Legal Executive Universal 	<p>Specifies the paper size loaded in each tray</p> <p>Notes:</p> <ul style="list-style-type: none"> • Letter is the US factory default setting. A4 is the international factory default setting. • If the same size and type of paper are in two trays and the Paper Size and Paper Type settings match, the trays are automatically linked. When one tray is empty, the job prints using the linked tray.
<p>Tray <x> Type</p> <ul style="list-style-type: none"> Plain Paper Glossy Paper Card Stock Transparency Recycled Letterhead Colored Paper Labels Bond Preprinted Light Paper Heavy Paper Rough/Cotton Custom Type <x> 	<p>Specifies the type of paper loaded in each tray</p> <p>Notes:</p> <ul style="list-style-type: none"> • Plain Paper is the factory default setting for Tray 1. Custom Type <x> is the factory default setting for all other trays. • If available, a user-defined name will appear instead of Custom Type <x>. • Use this menu item to configure automatic tray linking.
<p>Note: Only installed trays, drawers, and feeders are listed in this menu.</p>	

Menu item	Description
<p>MP Feeder Size</p> <ul style="list-style-type: none"> A4 A5 JIS B5 A6 Statement Letter Folio Oficio (Mexico) Legal Executive Universal 7 3/4 Envelope 9 Envelope 10 Envelope DL Envelope B5 Envelope C5 Envelope Other Envelope 	<p>Specifies the paper size loaded in the multipurpose feeder</p> <p>Notes:</p> <ul style="list-style-type: none"> • The 650-sheet duo drawer must be installed in order for MP Feeder to appear as a menu setting in the Paper menu. • Letter is the US factory default setting. A4 is the international factory default setting. • The multipurpose feeder does not automatically sense paper size. The paper size value must be set.
<p>MP Feeder Type</p> <ul style="list-style-type: none"> Plain Paper Glossy Paper Card Stock Transparency Recycled Letterhead Colored Paper Labels Bond Envelope Preprinted Light Paper Heavy Paper Rough/Cotton Custom Type <x> 	<p>Specifies the type of paper loaded in the multipurpose feeder</p> <p>Notes:</p> <ul style="list-style-type: none"> • The 650-sheet duo drawer must be installed in order for MP Feeder to appear as a menu setting in the Paper menu. • Plain paper is the factory default setting.
<p>Note: Only installed trays, drawers, and feeders are listed in this menu.</p>	

Menu item	Description
<p>Manual Paper Size</p> <ul style="list-style-type: none"> A4 A5 JIS B5 A6 Statement Letter Folio Oficio (Mexico) Legal Executive Universal 	<p>Specifies the size of the paper being manually loaded</p> <p>Note: Letter is the US factory default setting. A4 is the international factory default setting.</p>
<p>Manual Paper Type</p> <ul style="list-style-type: none"> Plain Paper Glossy Paper Card Stock Transparency Recycled Letterhead Colored Paper Labels Bond Preprinted Light Paper Heavy Paper Rough/Cotton Custom Type <x> 	<p>Specifies the type of paper being manually loaded</p> <p>Note: Plain Paper is the factory default setting.</p>
<p>Manual Envelope Size</p> <ul style="list-style-type: none"> 7 3/4 Envelope 9 Envelope 10 Envelope DL Envelope B5 Envelope C5 Envelope Other Envelope 	<p>Specifies the size of the envelope being manually loaded</p> <p>Note: 10 Envelope is the US factory default setting. DL Envelope is the international factory default setting.</p>
<p>Manual Envelope Type</p> <ul style="list-style-type: none"> Envelope Custom Type <x> 	<p>Specifies the type of envelope being manually loaded</p> <p>Note: Envelope is the factory default setting.</p>
<p>Note: Only installed trays, drawers, and feeders are listed in this menu.</p>	

Paper Texture menu

Menu item	Description
Plain Texture Smooth Normal Rough	Specifies the relative texture of the paper loaded in a specific tray Note: Normal is the factory default setting.
Card Stock Texture Smooth Normal Rough	Specifies the relative texture of the card stock loaded in a specific tray Notes: <ul style="list-style-type: none"> • Normal is the factory default setting. • Settings appear only if card stock is supported.
Transparency Texture Smooth Normal Rough	Specifies the relative texture of the transparencies loaded in a specific tray Note: Normal is the factory default setting.
Recycled Texture Smooth Normal Rough	Specifies the relative texture of the recycled paper loaded in a specific tray Note: Normal is the factory default setting.
Glossy Texture Smooth Normal Rough	Specifies the relative texture of the Glossy paper loaded in a specific tray Note: Normal is the factory default setting.
Labels Texture Smooth Normal Rough	Specifies the relative texture of the labels loaded in a specific tray Note: Normal is the factory default setting.
Bond Texture Smooth Normal Rough	Specifies the relative texture of the paper loaded in a specific tray Note: Rough is the factory default setting.
Envelope Texture Smooth Normal Rough	Specifies the relative texture of the envelopes loaded in a specific tray Note: Normal is the factory default setting.
Letterhead Texture Smooth Normal Rough	Specifies the relative texture of the paper loaded in a specific tray Note: Normal is the factory default setting.

Menu item	Description
Preprinted Texture Smooth Normal Rough	Specifies the relative texture of the paper loaded in a specific tray Note: Normal is the factory default setting.
Colored Texture Smooth Normal Rough	Specifies the relative texture of the colored paper loaded in a specific tray Note: Normal is the factory default setting.
Light Paper Smooth Normal Rough	Specifies the relative texture of the light paper loaded in a specific tray Notes: <ul style="list-style-type: none"> • Normal is the factory default setting. • Settings appear only if the custom type is supported.
Heavy Paper Smooth Normal Rough	Specifies the relative texture of the heavy paper loaded in a specific tray Notes: <ul style="list-style-type: none"> • Normal is the factory default setting. • Settings appear only if the custom type is supported.
Rough/Cotton Paper Rough	Specifies the relative texture of the rough/cotton paper loaded in a specific tray Notes: <ul style="list-style-type: none"> • Rough is the factory default setting. • Settings appear only if the custom type is supported.
Custom <x> Paper Smooth Normal Rough	Specifies the relative texture of the custom paper loaded in a specific tray Notes: <ul style="list-style-type: none"> • Normal is the factory default setting. • Settings appear only if the custom type is supported.

Paper Weight menu

Menu items	Definition
Plain Weight, Glossy Weight, Bond Weight, Letterhead Weight, Preprinted Weight, or Colored Weight Light Normal Heavy	Identifies the relative weight of the paper loaded in a specific tray Note: Normal is the factory default setting.
Transparency Weight Light Normal Heavy	Identifies the relative weight of the transparencies loaded in a specific tray Note: Normal is the factory default setting.

Menu items	Definition
Recycled Weight Light Normal Heavy	Identifies the relative weight of the recycled paper loaded in a specific tray Note: Normal is the factory default setting.
Labels Weight Light Normal Heavy	Identifies the relative weight of the labels loaded in a specific tray Note: Normal is the factory default setting.
Envelope Weight Light Normal Heavy	Identifies the relative weight of the envelopes loaded in a specific tray or feeder Note: Normal is the factory default setting.
Card Stock Weight Light Normal Heavy	Identifies the relative weight of the card stock loaded in a specific tray Notes: <ul style="list-style-type: none"> • Normal is the factory default setting. • Settings appear only if card stock is supported.
Light Paper Weight Light	Identifies the relative weight of the light paper loaded in a specific tray Notes: <ul style="list-style-type: none"> • Light is the factory default setting. • Settings appear only if light paper is supported.
Heavy Paper Weight Heavy	Identifies the relative weight of the heavy paper loaded in a specific tray Notes: <ul style="list-style-type: none"> • Heavy is the factory default setting. • Settings appear only if heavy paper is supported.
Rough/Cotton Paper Weight Normal	Identifies the relative weight of the rough/cotton paper loaded in a specific tray Notes: <ul style="list-style-type: none"> • Normal is the factory default setting. • Settings appear only if rough/cotton paper is supported.

Menu items	Definition
Custom <x> Light Normal Heavy	Identifies the relative weight of the custom paper type loaded in a specific tray Notes: <ul style="list-style-type: none"> • Normal is the factory default setting. • Settings appear only if custom paper is supported.

Paper Loading menu

Note: Certain options are not available on selected printer models.

Menu item	Description
Recycled Loading Duplex Off	Determines whether 2-sided printing occurs for all jobs that specify Recycled as the paper type Note: Off is the factory default setting.
Glossy Loading Duplex Off	Determines whether 2-sided printing occurs for all jobs that specify Glossy as the paper type Note: Off is the factory default setting.
Bond Loading Duplex Off	Determines whether 2-sided printing occurs for all jobs that specify Bond as the paper type Note: Off is the factory default setting.
Letterhead Loading Duplex Off	Determines whether 2-sided printing occurs for all jobs that specify Letterhead as the paper type Note: Off is the factory default setting.
Preprinted Loading Duplex Off	Determines whether 2-sided printing occurs for all jobs that specify Preprinted as the paper type Note: Off is the factory default setting.
Colored Loading Duplex Off	Determines whether 2-sided printing occurs for all jobs that specify Colored as the paper type Note: Off is the factory default setting.
Light Paper Loading Duplex Off	Determines whether 2-sided printing occurs for all jobs that specify Light Paper as the paper type Note: Off is the factory default setting.
Heavy Paper Loading Duplex Off	Determines whether 2-sided printing occurs for all jobs that specify Heavy Paper as the paper type Note: Off is the factory default setting.
Note: Duplex sets the printer default to 2-sided printing for every print job unless 1-sided printing is selected from Print Properties (in Windows) or the Print dialog (in Macintosh).	

Menu item	Description
Rough/Cotton Loading Duplex Off	Determines whether 2-sided printing occurs for all jobs that specify Rough/Cotton as the paper type Note: Off is the factory default setting.
Custom <x> Loading Duplex Off	Determines whether 2-sided printing occurs for all jobs that specify Custom <x> as the paper type Notes: <ul style="list-style-type: none"> • Off is the factory default setting. • Custom <x> Loading is available only if the custom type is supported.
Note: Duplex sets the printer default to 2-sided printing for every print job unless 1-sided printing is selected from Print Properties (in Windows) or the Print dialog (in Macintosh).	

Custom Types menu

Menu item	Description
Custom Type <x> Paper Card Stock Transparency Glossy Labels Envelope Rough/Cotton	Associates a paper or specialty media type with a factory default Custom Type <x> name or a user-defined Custom Name created from the Embedded Web Server or MarkVision™ Professional. This user-defined name displays instead of Custom Type <x> . Notes: <ul style="list-style-type: none"> • Paper is the factory default setting. • The custom media type must be supported by the selected tray or feeder in order for you to print from that source.
Recycled Paper Card Stock Transparency Glossy Labels Envelope Cotton	Specifies a paper type when the Recycled setting is selected in other menus Notes: <ul style="list-style-type: none"> • Paper is the factory default setting. • The Recycled type must be supported by the selected tray or feeder in order for you to print from that source.

Universal Setup menu

These menu items are used to specify the height, width, and feed direction of the Universal Paper Size. The Universal Paper Size is a user-defined paper size setting. It is listed with the other paper size settings and includes similar options, such as support for duplex printing and printing multiple pages on one sheet.

Menu item	Description
Units of Measure Inches Millimeters	Identifies the units of measure Notes: <ul style="list-style-type: none"> • Inches is the US factory default setting. • Millimeters is the international factory default setting.
Portrait Width 3–14.17 inches 76–360 mm	Sets the portrait width Notes: <ul style="list-style-type: none"> • If the width exceeds the maximum, the printer uses the maximum width allowed. • 8.5 inches is the US factory default setting. Inches can be increased in 0.01-inch increments. • 216 mm is the international factory default setting. Millimeters can be increased in 1-mm increments.
Portrait Height 3–14.17 inches 76–360 mm	Sets the portrait height Notes: <ul style="list-style-type: none"> • If the height exceeds the maximum, the printer uses the maximum height allowed. • 14 inches is the US factory default setting. Inches can be increased in 0.01-inch increments. • 356 mm is the international factory default setting. Millimeters can be increased in 1-mm increments.
Feed Direction Short Edge Long Edge	Specifies the feed direction Notes: <ul style="list-style-type: none"> • Short Edge is the factory default setting. • Long Edge appears only if the longest edge is shorter than the maximum length supported in the tray.

Reports

Menu Settings Page menu

Menu item	Description
Menu Settings Page	Prints a report containing information about paper loaded into trays, installed memory, the total page count, alarms, timeouts, the printer control panel language, the TCP/IP address, the status of supplies, the status of the network connection, and other information Note: The page prints when this item is selected.

Device Statistics menu

Menu item	Description
Device Statistics	Prints a report containing printer statistics such as supply information and details about printed pages Note: The page prints when this item is selected.

Network Setup Page menu

Menu item	Description
Network Setup Page	Prints a report containing information about the network settings, such as TCP/IP address information Notes: <ul style="list-style-type: none">• This menu item appears only for printers with a network print server installed.• The page prints when this item is selected.

Profile List menu

Menu item	Description
Print profiles	Prints a list of profiles stored in the printer Note: The page prints when this item is selected.

Print Fonts menu

Menu item	Description
Print Fonts PCL Fonts PostScript Fonts PPDS Fonts	Prints a sample of all the fonts available for the printer language currently set in the printer Note: A separate list is available for PCL, PostScript, and PPDS emulations.

Print Directory menu

Menu item	Description
Print Directory	Prints a list of all the resources stored on an optional flash memory card Notes: <ul style="list-style-type: none">• The optional flash memory or printer hard disk must be installed correctly and working properly.• The page prints when this item is selected.

Print Defects menu

Menu item	Description
Print Defects	Prints a diagnostic list of problems Notes: <ul style="list-style-type: none">• The page prints when this item is selected.• The list should be printed on letter- or A4-size paper.

Print Demo menu

Menu item	Description
Print Demo	Prints a list of any resident demo pages Note: The page prints when this item is selected.

Asset Report menu

Menu item	Description
Asset Report	Prints an asset report page Note: The page prints when this item is selected.

Network/Ports

Active NIC menu

Menu item	Description
Active NIC Auto List of networks	Shows the print server Note: This menu is available only for network models or printers attached to print servers.

Network menu

Menu item	Description
PCL SmartSwitch On Off	Sets the printer to automatically switch to PCL emulation when a print job requires it, regardless of the default printer language Notes: <ul style="list-style-type: none"> • On is the factory default setting. • When the Off setting is used, the printer does not examine incoming data. • When the Off setting is used, the printer uses PostScript emulation if PS SmartSwitch is set to On. It uses the default printer language specified in the Setup menu if PS SmartSwitch is set to Off.
PS SmartSwitch On Off	Sets the printer to automatically switch to PS emulation when a print job requires it, regardless of the default printer language Notes: <ul style="list-style-type: none"> • On is the factory default setting. • When the Off setting is used, the printer does not examine incoming data. • When the Off setting is used, the printer uses PCL emulation if PCL SmartSwitch is set to On. It uses the default printer language specified in the Setup menu if PCL SmartSwitch is set to Off.
NPA Mode Off Auto	Sets the printer to perform the special processing required for bidirectional communication following the conventions defined by the NPA protocol Notes: <ul style="list-style-type: none"> • Auto is the factory default setting. • Changing this setting from the printer control panel and then exiting the menus causes the printer to restart. The menu selection is updated.
Network Buffer Disabled Auto	Controls the network input buffer Notes: <ul style="list-style-type: none"> • Auto is the factory default setting. • The maximum size allowed depends on the amount of memory in the printer, the size of the other link buffers, and whether Resource Save is set to On or Off. • Changing this setting from the printer control panel and then exiting the menus causes the printer to restart. The menu selection is updated.
Mac Binary PS On Off Auto	Sets the printer to process Macintosh binary PostScript print jobs Notes: <ul style="list-style-type: none"> • Auto is the factory default setting. • The Off setting filters print jobs using the standard protocol. • The On setting processes raw binary PostScript print jobs.

Menu item	Description
Network Setup Reports Menu Network Card menu TCIP Menu IPv6 Menu Wireless menu AppleTalk menu SE Menu	List all the network setup menus, regardless of the active printer network Note: Certain options are not available on selected printer models.

Wireless menu

Use the following menu items to view or configure the wireless internal print server settings.

Note: This menu is available only for network models or printers attached to print servers when an optional wireless internal print server is installed in the printer.

Menu item	Description
Mode Infrastructure Ad hoc	Lets you select a mode Notes: <ul style="list-style-type: none"> Infrastructure mode makes the printer wireless network accessible through an access point. Ad hoc mode configures the printer for peer-to-peer wireless networking.
Network Name <list of available network names>	Lets you select an available network for the printer to use

USB menu

Menu item	Description
PCL SmartSwitch On Off	Sets the printer to automatically switch to PCL emulation when a print job requires it, regardless of the default printer language Notes: <ul style="list-style-type: none"> On is the factory default setting. When the Off setting is used, the printer does not examine incoming data. When the Off setting is used, the printer uses PostScript emulation if PS SmartSwitch is set to On. It uses the default printer language specified in the Setup menu if PS SmartSwitch is set to Off.

Menu item	Description
PS SmartSwitch On Off	Sets the printer to automatically switch to PS emulation when a print job requires it, regardless of the default printer language Notes: <ul style="list-style-type: none"> • On is the factory default setting. • When the Off setting is used, the printer does not examine incoming data. • When the Off setting is used, the printer uses PCL emulation if PCL SmartSwitch is set to On. It uses the default printer language specified in the Setup menu if PCL SmartSwitch is set to Off.
NPA Mode Off Auto	Sets the printer to perform the special processing required for bidirectional communication following the conventions defined by the NPA protocol Notes: <ul style="list-style-type: none"> • Auto is the factory default setting. • Changing this setting from the printer control panel and then exiting the menus causes the printer to restart. The menu selection is updated.
USB Buffer Disabled Auto	Controls the USB port buffer Notes: <ul style="list-style-type: none"> • Auto is the factory default setting. • The maximum size allowed depends on the amount of memory in the printer, the size of the other link buffers, and whether Resource Save is set to On or Off. • To increase the maximum size range for the Network Buffer, disable or reduce the size of the parallel, serial, and USB buffers. • Changing this setting from the printer control panel and then exiting the menus causes the printer to restart. The menu selection is updated.
Mac Binary PS On Off Auto	Sets the printer to process Macintosh binary PostScript print jobs Notes: <ul style="list-style-type: none"> • Auto is the factory default setting. • The Off setting filters print jobs using the standard protocol. • The On setting processes raw binary PostScript print jobs.
ENA Address	Sets the network address information for an external print server that is attached to the printer using a USB cable Note: This menu item is available only if the printer is attached to an external printer server through the USB port.
ENA Netmask	Sets the netmask information for an external print server that is attached to the printer using a USB cable Note: This menu item is available only if the printer is attached to an external print server through the USB port.

Menu item	Description
ENA Gateway	<p>Sets the gateway information for an external print server that is attached to the printer using a USB cable</p> <p>Note: This menu item is available only if the printer is attached to an external print server through the USB port.</p>

Settings

General Settings menu

Menu item	Description
<p>Display Language</p> <ul style="list-style-type: none"> English Francais Deutsch Italiano Espanol Dansk Norsk Nederlands Svenska Portugues Suomi Russian Polski Magyar Turkce Cesky Simplified Chinese Traditional Chinese Korean Japanese 	<p>Sets the language of the text appearing on the display</p> <p>Note: All languages may not be available for all printers.</p>

Menu item	Description
Eco-Mode Off Energy Energy/Paper Paper	Allows the printer to conserve energy by turning off the backlight on the display and entering one minute power saver Notes: <ul style="list-style-type: none"> • Off is the factory default setting. Off resets the printer to its factory default settings. • The Energy setting minimizes the power used by the printer. Performance may be affected, but print quality is not. • Energy/Paper minimizes the use of power and of paper and specialty media. • Paper minimizes the amount of paper and specialty media needed for a print job. Performance may be affected, but print quality is not.
Quiet Mode Off On	Enables the printer to print more slowly and with less noise Notes: <ul style="list-style-type: none"> • Off is the factory default setting. • On configures the printer to produce as little noise as possible.
Run Initial Setup Yes No	Instructs the printer to run the setup wizard Notes: <ul style="list-style-type: none"> • Yes is the factory default setting. • After completing the setup wizard by selecting Done at the Country select screen, the default setting becomes No.
Alarms Cartridge Alarm Off Single	Sets an alarm to sound when the printer requires operator intervention Note: Off is the factory default setting and means no alarm will sound.
Print Recovery Auto Continue Disabled 5 sec –255 sec	Lets the printer automatically continue printing from certain offline situations when not resolved within the specified time period Note: Disabled is the factory default setting.
Print Recovery Jam Recovery On Off Auto	Specifies whether the printer reprints jammed pages Notes: <ul style="list-style-type: none"> • Auto is the factory default setting. The printer reprints jammed pages unless the memory required to hold the pages is needed for other printer tasks. • On sets the printer to always reprint jammed pages. • Off sets the printer to never reprint jammed pages.

Menu item	Description
Print Recovery Page Protect Off On	Lets the printer successfully print a page that may not have printed otherwise Notes: <ul style="list-style-type: none"> • Off is the factory default setting. Off prints a partial page when there is not enough memory to print the whole page. • On sets the printer to process the whole page so that the entire page prints.
Timeouts Power Saver Disabled 1–240	Specifies the number of minutes of inactivity before some systems begin entering a minimum power state. Note: 30 minutes is the factory default setting.
Timeouts Screen Timeout 15–300	Sets the amount of time in seconds the printer waits before returning the printer display to a Ready state Note: 30 seconds is the factory default setting.
Timeouts Print Timeout Disabled 1–255	Sets the amount of time in seconds the printer waits to receive an end-of-job message before canceling the remainder of the print job Notes: <ul style="list-style-type: none"> • 90 seconds is the factory default setting. • When the timer expires, any partially printed page still in the printer is printed, and then the printer checks to see if any new print jobs are waiting. • Print Timeout is available only when using PCL or PPDS emulation. This setting has no effect on PostScript emulation print jobs.
Timeouts Wait Timeout Disabled 15–65535	Sets the amount of time in seconds the printer waits for additional data before canceling a print job Notes: <ul style="list-style-type: none"> • 40 seconds is the factory default setting. • Wait Timeout is available only when the printer is using PostScript emulation. This setting has no effect on PCL or PPDS emulation print jobs.
Factory Defaults Do Not Restore Restore	Returns the printer settings to the factory default settings Notes: <ul style="list-style-type: none"> • Do Not Restore is the factory default setting. Do Not Restore keeps the user-defined settings. • Restore returns all printer settings to the factory default settings except Network/Ports menu settings. All downloads stored in RAM are deleted. Downloads stored in flash memory or on a printer hard disk are not affected.

Setup menu

Menu item	Description
Printer Language PS Emulation PCL Emulation PPDS Emulation	Determines which printer language the print server uses to send data to the printer Note: PS Emulation is the factory default setting.
Print Area Normal Fit to Page Whole Page	Sets the print area Note: Normal is the factory default setting.
Download Target RAM Flash	Collects permanent resources that have been downloaded on the printer and automatically writes them to the flash drive Note: RAM is the factory default setting.
Resource Save On Off	Saves the permanently downloaded resources Note: Off is the factory default setting.

Finishing menu

Note: Certain options are not available on selected printer models.

Menu item	Description
Duplex 2 Sided 1 Sided	Specifies whether duplex (2-sided) printing is set as the default for all print jobs Notes: <ul style="list-style-type: none"> • Off is the factory default setting. • To set 2-sided printing from the software program: for Windows users, click File → Print, and then click Properties, Preferences, Options, or Setup and adjust the settings; for Macintosh users, click File > Print, and then adjust the settings from the Print dialog and pop-up menus.
Duplex Bind Long Edge Short Edge	Defines the way duplexed pages are bound and how the printing on the back of the page is oriented in relation to the printing on the front of the page Notes: <ul style="list-style-type: none"> • Long Edge is the factory default setting. • Long Edge specifies that binding be placed on the left edge of portrait pages and the top edge of landscape pages. • Short Edge specifies that binding be placed on the top edge of portrait pages and the left edge of landscape pages.

Menu item	Description
Copies 1–999	Specifies a default number of copies for each print job Notes: <ul style="list-style-type: none"> • 1 is the factory default setting. • To specify the number of copies for a specific print job from the software program: click File → Print, and then click Properties, Preferences, Options, or Setup and adjust the settings; for Macintosh users, click File > Print, and then adjust the settings from the Print dialog and pop-up menus. Software settings always override printer control panel settings.
Blank Pages Do Not Print Print	Specifies whether blank pages are inserted in a print job Note: Do Not Print is the factory default setting.
Collate On [1, 2, 1, 2, 1, 2] Off [1, 1, 1, 2, 2, 2]	Stacks the pages of a print job in sequence when printing multiple copies Notes: <ul style="list-style-type: none"> • Off is the factory default setting. No pages will be collated. • The On setting stacks the print job sequentially. • Both settings print the entire job the number of times specified by the Copy menu setting.
Separator Sheets None Between Copies Between Jobs Between Pages	Specifies whether blank separator sheets are inserted Notes: <ul style="list-style-type: none"> • None is the factory default setting. • Between Copies inserts a blank sheet between each copy of a print job if Collation is set to On. If Collation is set to Off, a blank page is inserted between each set of printed pages, such as after all page 1's, all page 2's, and so on. • Between Jobs inserts a blank sheet between print jobs. • Between Pages inserts a blank sheet between each page of the print job. This setting is useful when printing transparencies or inserting blank pages in a document for notes.
Separator Source Tray <x> MP Feeder	Specifies the paper source for separator sheets Notes: <ul style="list-style-type: none"> • Tray 1 (standard tray) is the factory default setting. • From the Paper menu, Configure MP must be set to Cassette in order for MP Feeder to appear as a menu setting.

Menu item	Description
N-Up Off 2 Up 3 Up 4 Up 6 Up 9 Up 12 Up 16 Up	Specifies that multiple-page images be printed on one side of a sheet of paper Note: The number selected is the number of page images that will print per side.
Orientation Auto Landscape Portrait	Specifies the orientation of a multiple-page sheet Notes: <ul style="list-style-type: none"> • Auto is the factory default setting. The printer chooses between portrait and landscape. • Long Edge uses landscape. • Short Edge uses portrait.
N-Up Border None Solid	Prints a border around each page image Note: None is the factory default setting.

Quality menu

Menu item	Description
Color Correction Auto Off Manual	Adjusts the color output on the printed page Notes: <ul style="list-style-type: none"> • Auto is the factory default setting. Auto applies different color conversion tables to each object on the printed page. • Off turns off color correction. • Manual allows customization of the color tables using the settings available from the Manual Color menu. • Due to the differences in additive and subtractive colors, certain colors that appear on computer monitors are impossible to duplicate on the printed page.
Print Resolution 4800 CQ 1200 dpi	Specifies the printed output resolution

Menu item	Description
Toner Darkness 1–5	Lightens or darkens the printed output Notes: <ul style="list-style-type: none"> • 4 is the factory default setting. • Selecting a smaller number can help conserve toner. • If Print Mode is set to Black Only, a setting of 5 increases toner density and darkness to all print jobs. • If Print Mode is set to Color, a setting of 5 is the same as a setting of 4.
Enhance Fine Lines On Off	Enables a print mode preferable for files such as architectural drawings, maps, electrical circuit diagrams, and flow charts Note: To set Enhance Fine Lines from the software program: for Windows users, click File → Print , and then click Properties, Preferences, Options, or Setup ; for Macintosh users, choose File > Print , and then adjust the settings from the Print dialog and pop-up menus.
Color Saver On Off	Reduces the amount of toner used for graphics and images. The amount of toner used for text is not reduced. Notes: <ul style="list-style-type: none"> • Off is the factory default setting. • On overrides Toner Darkness settings.
RGB Brightness -6–6	Adjusts brightness in color outputs Notes: <ul style="list-style-type: none"> • 0 is the factory default setting. • -6 is the maximum decrease. 6 is the maximum increase. • This does not affect files where CMYK color specifications are being used.
RGB Contrast 0–5	Adjusts contrast in color outputs Notes: <ul style="list-style-type: none"> • 0 is the factory default setting. • This does not affect files where CMYK color specifications are being used.
RGB Saturation 0–5	Adjusts saturation in color outputs Notes: <ul style="list-style-type: none"> • 0 is the factory default setting. • This does not affect files where CMYK color specifications are being used.

Menu item	Description
Color Balance Cyan -5-5 Magenta -5-5 Yellow -5-5 Black -5-5	Adjusts color in printed output by increasing or decreasing the amount of toner being used for each color Note: 0 is the factory default setting.
Color Balance Reset Defaults	Restores the Color Balance factory default settings
Color Samples sRGB Display sRGB Vivid Display—True Black Vivid Off—RGB US CMYK Euro CMYK Vivid CMYK Off—CMYK	Prints sample pages for each of the RGB and CMYK color conversion tables used in the printer Notes: <ul style="list-style-type: none"> • Selecting any setting prints the sample. • Color samples consist of a series of colored boxes along with the RGB or CMYK combination that creates the color observed. These pages can be used to help decide which combinations to use to get the desired printed output. • From a browser window, type the IP address of the printer to access a complete list of color sample pages from the Embedded Web Server.
Manual Color RGB Image Vivid sRGB Display Display—True Black sRGB Vivid Off RGB Text Vivid sRGB Display Display—True Black sRGB Vivid Off RGB Graphics Vivid sRGB Display Display—True Black sRGB Vivid Off	Customizes the RGB color conversions Notes: <ul style="list-style-type: none"> • sRGB Display is the factory default setting for RGB Image. This applies a color conversion table to an output that matches the colors displayed on a computer monitor. • sRGB Vivid is the factory default setting for RGB Text and RGB Graphics. sRGB Vivid applies a color table that increases saturation. This is preferred for business graphics and text. • Vivid applies a color conversion table that produces brighter, more saturated colors. • Display—True Black applies a color conversion table that uses only black toner for neutral gray colors. • Off turns off color conversion.

Menu item	Description
Manual Color CMYK Image US CMYK Euro CMYK Vivid CMYK Off CMYK Text US CMYK Euro CMYK Vivid CMYK Off CMYK Graphics US CMYK Euro CMYK Vivid CMYK Off	Customizes the CMYK color conversions Notes: <ul style="list-style-type: none"> • US CMYK is the US factory default setting. US CMYK applies a color conversion table that tries to produce output that matches SWOP color output. • Euro CMYK is the international factory default setting. Euro CMYK applies a color conversion table that tries to produce output that matches EuroScale color output. • Vivid CMYK increases color saturation for the US CMYK color conversion table. • Off turns off color conversion.
Color Adjust	Initiates an automatic color adjust calibration.

Utilities menu

Menu item	Description
Format Flash No Yes	Formats the flash memory. Flash memory refers to the memory added by installing an optional flash memory card in the printer. Warning—Potential Damage: Do not turn off the printer while the flash memory is formatting. Notes: <ul style="list-style-type: none"> • An optional flash memory card must be installed in the printer and operating properly for this menu item to be available. • No cancels the format request. • Selecting Yes deletes all data stored in flash memory.
Defragment Flash No Yes	Prepares the flash memory to receive new data by retrieving lost storage space Warning—Potential Damage: Do not turn off the printer while the flash memory is defragmenting. Notes: <ul style="list-style-type: none"> • An optional flash memory card must be installed in the printer and operating properly for this menu item to be available. The optional flash memory card must not be Read/Write or Write protected. • No cancels the defragment request. • Yes reformats the flash memory after transferring all downloads to regular printer memory. When formatting is complete, the downloads are loaded back into flash memory.

Menu item	Description
Hex Trace Activate	Assists in isolating the source of a print job problem Notes: <ul style="list-style-type: none"> • When Activate is selected, all data sent to the printer is printed in hexadecimal and character representation and control codes are not executed. • To exit Hex Trace, turn the printer off or reset the printer.
Coverage Estimator Off On	Provides an estimate of the percentage coverage of cyan, magenta, yellow, and black on a page. The estimate is printed on a separator page. Note: Off is the factory default setting.

PDF menu

Note: Certain options are not available on selected printer models.

Menu item	Description
Scale to Fit Yes No	Scales page content to fit the selected paper size Note: No is the factory default setting.
Annotations Do Not Print Print	Prints annotations in a PDF Note: Do Not Print is the factory default setting.

PostScript menu

Menu item	Description
Print PS Error On Off	Prints a page containing the PostScript error Note: Off is the factory default setting.
Font Priority Resident Flash	Establishes the font search order Notes: <ul style="list-style-type: none"> • Resident is the factory default setting. • A formatted flash memory option card or printer hard disk must be installed in the printer and operating properly for this menu item to be available. • The flash memory option or printer hard disk cannot be Read/Write, Write, or password protected. • Job Buffer Size must not be set to 100%.

Menu item	Description
Image Smoothing On Off	Enhances the contrast and sharpness of low-resolution images and smooths their color transitions Notes: <ul style="list-style-type: none"> • Off is the factory default setting. • Image Smoothing has no effect on images that are 300 dpi or higher in resolution.

PCL Emul menu

Menu item	Description
Font Source Resident Download Flash All	Specifies the set of fonts used by the Font Name menu item Notes: <ul style="list-style-type: none"> • Resident is the factory default setting. It shows the factory default set of fonts downloaded into RAM. • Flash settings show all fonts resident in that option. • Flash option must be properly formatted and cannot be Read/Write, Write, or password protected. • Download shows all the fonts downloaded into RAM. • All shows all fonts available to any option.
Font Name Courier	Identifies a specific font and the option where it is stored Notes: <ul style="list-style-type: none"> • Courier is the factory default setting. • Courier shows the font name, font ID, and storage location in the printer. The font source abbreviation is R for Resident, F for Flash, and D for Download.
Symbol Set 10U PC-8 12U PC-850	Specifies the symbol set for each font name Notes: <ul style="list-style-type: none"> • 10U PC-8 is the US factory default setting. • 12U PC-850 is the international factory default setting. • A symbol set is a set of alphabetic and numeric characters, punctuation, and special symbols. Symbol sets support the different languages or specific programs such as math symbols for scientific text. Only the supported symbol sets are shown.
PCL Emulation Settings Point Size 1.00–1008.00	Changes the point size for scalable typographic fonts Notes: <ul style="list-style-type: none"> • 12 is the factory default setting. • Point Size refers to the height of the characters in the font. One point equals approximately 1/72 of an inch. • Point sizes can be increased or decreased in 0.25-point increments.

Menu item	Description
PCL Emulation Settings Pitch 0.08–100	Specifies the font pitch for scalable monospaced fonts Notes: <ul style="list-style-type: none"> • 10 is the factory default setting. • Pitch refers to the number of fixed-space characters per inch (dpi). • Pitch can be increased or decreased in 0.01-dpi increments. • For nonscalable monospaced fonts, the pitch appears on the display but cannot be changed.
PCL Emulation Settings Orientation Portrait Landscape	Specifies the orientation of text and graphics on the page Notes: <ul style="list-style-type: none"> • Portrait is the factory default setting. • Portrait prints text and graphics parallel to the short edge of the page. • Landscape prints text and graphics parallel to the long edge of the page.
PCL Emulation Settings Lines per Page 1–255 60 64	Specifies the number of lines that print on each page Notes: <ul style="list-style-type: none"> • 60 is the US factory default setting. 64 is the international default setting. • The printer sets the amount of space between each line based on the Lines per Page, Paper Size, and Orientation settings. Select the desired Paper Size and Orientation before setting Lines per Page.
PCL Emulation Settings A4 Width 198 mm 203 mm	Sets the printer to print on A4-size paper Notes: <ul style="list-style-type: none"> • 198 mm is the factory default setting. • The 203-mm setting sets the width of the page to allow the printing of eighty 10-pitch characters.
PCL Emulation Settings Auto CR after LF On Off	Specifies whether the printer automatically performs a carriage return (CR) after a line feed (LF) control command Notes: <ul style="list-style-type: none"> • Off is the factory default setting. • Setting alterations are duplicated in the PPDS menu.
PCL Emulation Settings Auto LF after CR On Off	Specifies whether the printer automatically performs a line feed (LF) after a carriage return (CR) control command Notes: <ul style="list-style-type: none"> • Off is the factory default setting. • Setting alterations are duplicated in the PPDS menu.

Menu item	Description
Tray Renumber Assign MP Feeder Off None 0–199 Assign Tray <x> Off None 0–199 Assign Manual Paper Off None 0–199 Assign Man Env Off None 0–199	Configures the printer to work with printer software or programs that use different source assignments for trays, drawers, and feeders Notes: <ul style="list-style-type: none"> • Off is the factory default setting. • None is not an available selection. It is displayed only when it is selected by the PCL 5 interpreter. • None ignores the Select Paper Feed command. • 0–199 allows a custom setting to be assigned.
Tray Renumber View Factory Def None	Displays the factory default setting assigned to each tray, drawer, or feeder
Tray Renumber Restore Defaults Yes No	Returns all tray, drawer, and feeder assignments to the factory default settings

Image menu

Menu item	Description
Auto Fit On Off	Selects the optimal paper size, scaling, and orientation Notes: <ul style="list-style-type: none"> • On is the factory default setting. • The On setting overrides scaling and orientation settings for some images.
Invert On Off	Inverts bi-tonal monochrome images Notes: <ul style="list-style-type: none"> • Off is the factory default setting. • The font size can be increased in 1-point increments. • This setting does not apply to GIF or JPEG images.

Menu item	Description
Scaling Anchor Top Left Best Fit Anchor Center Fit Height/Width Fit Height Fit Width	Scales the image to fit the selected paper size Notes: <ul style="list-style-type: none"> • Best Fit is the factory default setting. • When Auto Fit is set to On, Scaling is automatically set to Best Fit.
Orientation Portrait Landscape Rev Portrait Rev Landscape	Sets the image orientation Note: Portrait is the factory default setting.

PictBridge menu

Note: Certain options are not available on selected printer models.

Menu item	Description
Photo Size Auto is the default L 2L Hagaki Postcard Card Size 100 x 150 mm 4 x 6 in 8 x 10 in Letter A4 A5 JIS B5	Controls the printed size of each photo printed from a PictBridge-enabled device Note: If both the printer and the PictBridge-enabled camera have a value for this setting, the camera value <i>always</i> supersedes the printer value.
Layout Auto is the default Off 2 Up 3 Up 4 Up 6 Up 9 Up 12 Up 16 Up Index Print	Determines the maximum number of images that can print on one side of paper Note: If both the printer and the PictBridge-enabled camera have a value for this setting, the camera value <i>always</i> supersedes the printer value.

Menu item	Description
Quality Normal Draft Fine	Determines which resolution, toner darkness, and color saver values the device uses when printing photos sent from a PictBridge-enabled device Note: If both the printer and the PictBridge-enabled camera have a value for this setting, the camera value <i>always</i> supersedes the printer value.
Paper Source MP Feeder Tray <x> Manual Paper	Identifies the printer default input source when printing photos from a PictBridge-enabled device Note: A photo size larger than the size of the PictBridge default source's installed media cannot be selected.

Flash drive menu

Note: The USB Direct Interface is not available on selected printer models.

Menu item	Description
Enable Drive Enable Disable	Enables or disables the USB Direct port
Update Code Enable Disable	Enables or disables the flash drive's ability to update its firmware code by way of a USB device
Copies 1–999	Sets the number of copies the printer should produce for each page contained in a print job
Sides (Duplex) 2 sided 1 sided	Controls whether printer prints on one side or both sides of the paper

Understanding printer messages

List of status and error messages

Busy

Wait for the message to clear.

Calibrating

The printer is adjusting the color. Wait for the message to clear.

Close door

Close the upper and lower doors.

Check Config ID

The printer configuration ID is invalid. Contact Customer Support.

Check Model Name

Set a valid model name.

Check Serial Num

Set a valid serial number.

<color> Low

Replace the toner cartridge, and then wait for the message to clear.

Defragmenting Flash

The printer is performing the defragmentation operation on flash memory. Wait for the message to clear.

Warning—Potential Damage: Do not turn the printer off while this message appears on the display.

Flushing buffer

Wait for the message to clear.

Formatting Flash

Wait for the message to clear.

Warning—Potential Damage: Do not turn the printer off while this message appears on the display.

Hex Trace

This message appears between status messages and warnings. Wait for the message to clear.

Imaging Kit

Replace the imaging kit, and then press to clear the message and continue printing.

Insert Tray <x>

Insert the specified tray into the printer.

Invalid Engine Code

The engine code is invalid. Contact Customer Support.

Invalid Network Code

The network code is invalid. Contact Customer Support.

Load <src> with <custom type name>

Try one or more of the following:

- Load the specified paper to clear the message and continue printing.
- Press , and then press to cancel printing.

Load <src> with <x>

Try one or more of the following:

- Load the paper tray or other source with the correct paper type and size.
- Press , and then press to cancel printing.

Load single sheet feeder with <custom type name>

Try one or more of the following:

- Load the manual feeder with the correct paper type and size.
If no paper is in the manual feeder, load a sheet, and then press to clear the message and continue printing.
- Press to clear the message and continue printing.
The printer manually overrides the manual request, and then the job prints from an automatic source.
- Press , and then press to cancel printing.
- Define a name for each custom type (Custom 1–6) using the MarkVision utility. When the printer is prompting for one of the custom types, which has been named, then only the custom name is displayed.

Load single sheet feeder with <custom string>

Try one or more of the following:

- Load the manual feeder with the correct paper type and size.
If no paper is in the feeder, load a sheet, and then press to clear the message and continue printing.
- Select the paper type and size to manually override the manual request.
- Press , and then press to cancel printing.

Load single sheet feeder with <size>

Try one or more of the following:

- Load the manual feeder with the correct paper type and size.
If no paper is in the feeder, load a sheet of paper, and then press to clear the message and continue printing.
- Select the paper type and size to manually override the manual request.
- Press to clear the message and continue printing.
The printer manually overrides the manual request, and then paper prints from an automatic source.
- Press , and then press to cancel printing.

Load single sheet feeder with <type> <size>

Try one or more of the following:

- Load the manual feeder with the correct paper type and size.
If no paper is in the feeder, load a sheet, and then select to clear the message and continue printing.
- Press to clear the message and continue printing.
The printer manually overrides the manual request, and then paper prints from an automatic source.
- Press , and then press to cancel printing.

Output Bin Full

Try one or more of the following:

- Remove paper from the standard exit bin to clear the message and continue printing.
- Press to clear the message and continue printing.

Power Saver

The printer is saving power while it waits for the next print job.

- Send a job to print.
- Press to warm the printer to normal operating temperature. Afterwards, **Ready** appears.

Programming Code

The printer is receiving a file that is a code update. Wait for the message to clear.

Warning—Potential Damage: Do not turn the printer off while this message appears on the display.

Programming Flash

Fonts and macros are being written to flash. Wait for the message to clear.

Ready

The printer is ready to print.

Reload printed pages in Tray <x>

- Press to clear the message and continue processing the second side of the sheet.
- Press , and then press to cancel printing.

Remote Management Active

The printer is offline while it configures settings. Wait for the message to clear.

Remove paper from standard output bin

Try one or more of the following:

- Remove paper from the standard exit bin to clear the message and continue printing.
- Press to clear the message and continue printing.

Remove packaging material

Check for and remove any packaging materials from the toner cartridges.

Replace <color> cartridge

Replace the toner cartridge, and then press to clear the message and continue printing.

Tray <x> Empty

Try one or more of the following:

- Load the paper tray or other source with the correct paper type and size.
- Press , and then press to cancel the current job.

Tray <x> Low

Load the paper tray or other source with the correct paper type and size.

Tray <x> Missing

Insert the specified tray into the printer.

Unsupported USB device, please remove

Remove the unrecognized USB device.

Unsupported USB hub, please remove

Remove the unrecognized USB hub.

Unplug and change mode

Make sure that the camera is in a valid mode for PictBridge

Waiting

The printer has received data to print, but is waiting for an End-of-Job command, a Form Feed command, or additional data.

Try one or more of the following:

- Press to print the contents of the buffer.
- Cancel the current print job.

Waiting, too many events

Wait for the message to clear.

Warning—Potential Damage: Do not turn the printer off while this message appears on the display.

Waste Toner Box

The waste toner bottle is nearly full. Press to clear the message and continue printing.

30.yy <color> cartridge missing

Insert the missing toner cartridge to clear the message and continue printing.

31.yy Defective <color> Cartridge

Replace the defective toner cartridge with a new one.

31.yy Defective Imaging Kit

Replace the defective imaging kit with a new one.

32.yy Replace Unsupported <color> Cartridge

Replace the unsupported toner cartridge with a supported one.

34 Short paper

Try one or more of the following:

- Press to clear the message and continue printing.
- Press , and then press to cancel printing.

35 Insufficient memory to support Resource Save feature

The printer lacks sufficient memory to save settings. Install additional memory, or press to disable Resource Save and continue printing.

37 Insufficient memory to collate job

The printer prints the pages that were spooled prior to the collation message and collates the remainder of the print job.

Try one or more of the following:

- Press to clear the message and continue printing.
- Press , and then press to cancel printing.

37 Insufficient memory for Flash memory Defragment operation

The printer cannot defragment flash memory because the memory used to store undeleted flash resources is full.

- To perform the defragment operation, delete fonts, macros, and other data in the memory, or install additional printer memory, and then press to continue printing.
- Press , and then press to cancel printing.

38 Memory Full

The printer does not have enough memory available to continue printing. You cannot press because of this.

Try one or more of the following:

- Press , and then press to cancel printing.
- Simplify the print job by reducing the amount of text or graphics on a page and deleting unnecessary downloaded fonts or macros.
- Install additional printer memory.

39 Complex page, some data may not have printed

The page is too complex to print. Press , and then press to cancel printing.

40 <color> Invalid refill, change cartridge

Replace the toner cartridge with a new one.

50 PPDS Font Error

The printer has encountered a font error because a specific font may not be installed.

Try one or more of the following:

- Press to clear the message and continue printing.
- The printer cannot find the requested font. From the PPDS menu, select **Best Fit**, and then select **On**. The printer will find a similar font and reformat the affected text.
- Press , and then press to cancel printing.

51 Defective flash detected

Press to clear the message and continue printing.

52 Not enough free space in flash memory for resources

Try one or more of the following:

- Press to clear the message and continue printing.
- Delete fonts, macros, and other data stored in flash memory.
- Upgrade to a larger capacity flash memory.
- Press , and then press to cancel printing.

53 Unformatted flash detected

Try one or more of the following:

- Press to clear the message and continue printing.
- Format the flash memory. If the message remains, the flash memory may be defective and require replacing.

54 Standard <x> software error

The printer detects that a network port is installed, but cannot communicate with it. The printer disables all communication to the associated network interface.

Try one or more of the following:

- Press to clear the message and continue printing.
- Turn the power off and then back on to reset the printer.
- Upgrade (flash) the network firmware in the printer or print server.

54 Standard network software error

The printer detects unformatted flash memory when the power is turned on.

Try one or more of the following:

- Press to clear the message and continue printing.
- Turn the power off and then back on to reset the printer.
- Upgrade (flash) the network firmware in the printer or print server.
- Format the flash memory. If the error message remains, the flash memory may be defective and require replacing.

56 Standard USB port disabled

Try one or more of the following:

- Press to clear the message and continue printing.
The printer discards any data received through the USB port.
- Make sure the USB port is not set to Disabled.

58 Too many flash options installed

Too many optional flash memory cards or too many optional firmware cards are installed on the printer.

Try one or more of the following:

- Press to clear the message and continue printing.
- Remove extra flash options:
 - 1 Turn the printer off.
 - 2 Unplug the power cord from the wall outlet.
 - 3 Remove extra flash options.
 - 4 Connect the power cord to a properly grounded outlet.
 - 5 Turn the printer back on.

58 Too many trays attached

- 1 Turn the printer off.
- 2 Unplug the power cord from the wall outlet.
- 3 Remove the additional trays.
- 4 Connect the power cord to a properly grounded outlet.
- 5 Turn the printer back on.

59 Incompatible tray <x>

Remove the specified tray.

82 Replace waste toner box

Replace the waste toner bottle. For more information, see “Replacing the waste toner bottle” on page 114.

82.yy Waste toner box missing

Replace the waste toner bottle, and then press to clear the message and continue printing.

82.yy Waste toner box nearly full

Press to clear the message and continue printing.

88.yy <color> Cartridge is low

Press to clear the message and continue printing.

88.yy Replace <color> Cartridge

Replace the toner cartridge.

200.yy Paper jam <area name>

- 1 Clear the paper path.
- 2 Press to clear the message and continue printing.

201.yy Paper jam <area name>

- 1 Clear the paper path.
- 2 Remove the jammed paper below the fuser.
- 3 Press to clear the message and continue printing.

202.yy Paper jam <area name>

- 1 Clear the paper path.
- 2 Remove the jammed paper from the fuser.
- 3 Press to clear the message and continue printing.

230.yy Paper jam <area name>

- 1 Clear the paper path.
- 2 Open the front door, and then remove the jammed paper.
- 3 Close the front door.
- 4 Press to clear the message and continue printing.

Note: When there is more than one jam, the message displays the number of pages jammed.

235.yy Paper jam <area name>

- 1 Clear the paper path.
- 2 Open the front door, and then remove the jammed paper.
- 3 Close the front door.
- 4 Load the tray with the correct paper size.
- 5 Press to clear the message and continue printing.

Note: When there is more than one jam, the message displays the number of pages jammed.

24x.yy Paper jam <area name>

- 1 Clear the paper path.
- 2 Pull the tray out.
- 3 Remove the jammed paper.
- 4 Insert the tray.

If all jams are cleared, the printer resumes printing.

Note: When there is more than one jam, the message displays the number of pages jammed.

250.yy Paper jam <area name>

- 1** Clear the paper path.
- 2** Open the front door, and then remove the jammed paper.
- 3** Hold the fuser cover down, and then remove the jammed paper from inside the fuser.
- 4** Close the fuser cover, and then close the front door.
- 5** Press  to clear the message and continue printing.

940.01

Press down on the cyan toner cartridge to make sure it is installed properly. Turn the printer off, wait about 10 seconds, and then turn the printer back on

941.01

Press down on the magenta toner cartridge to make sure it is installed properly. Turn the printer off, wait about 10 seconds, and then turn the printer back on.

942.01

Press down on the yellow toner cartridge to make sure it is installed properly. Turn the printer off, wait about 10 seconds, and then turn the printer back on

943.01

Press down on the black toner cartridge to make sure it is installed properly. Turn the printer off, wait about 10 seconds, and then turn the printer back on

940.02

The cyan toner cartridge needs maintenance. Call for service.

941.02

The magenta toner cartridge needs maintenance. Call for service.

942.02

The yellow toner cartridge needs maintenance. Call for service.

943.02

The black toner cartridge needs maintenance. Call for service.

Maintaining the printer

Periodically, certain tasks are required to maintain optimum print quality.

Storing supplies

Choose a cool, clean storage area for the printer supplies. Store supplies right side up in their original packing until you are ready to use them.

Do not expose supplies to:

- Direct sunlight
- Temperatures above 35°C (95°F)
- High humidity above 80%
- Salty air
- Corrosive gases
- Heavy dust

Conserving supplies

There are some settings you can change from the control panel that will help you conserve toner and paper. For more information, see “Supplies menu,” “Quality menu,” and “Finishing menu.”



If you need to print several copies, you can conserve supplies by printing the first copy and checking it for accuracy before printing the remaining copies.

Checking the status of supplies

A message appears on the display when a replacement supply item is needed or when maintenance is required.

Checking the status of supplies from the printer control panel

You can check the status of printer supplies by printing a menu settings page:

- 1 Make sure the printer is on and **Ready** appears.
- 2 From the printer control panel, press .
- 3 Press the arrow buttons until **Reports** appears, and then press .
- 4 Press the arrow buttons until **Menu Settings Page** appears, and then press .

Checking the status of supplies from a network computer

Note: The computer must be connected to the same network as the printer.

1 Type the printer IP address into the address field of your Web browser.

Note: If you do not know the IP address of the printer, print a network setup page and locate the IP address in the TCP/IP section.

2 Click **Device Status**. The Device Status page appears, displaying a summary of supply levels.

Ordering supplies

To order supplies in the U.S., contact Lexmark at 1-800-539-6275 for information about Lexmark authorized supplies dealers in your area. In other countries or regions, visit the Lexmark Web Site at www.lexmark.com or contact the place where you purchased the printer.

Note: All life estimates for printer supplies assume printing on letter- or A4-size plain paper.

Ordering toner cartridges

When **88 Cyan Cartridge Low**, **88 Magenta Cartridge Low**, **88 Yellow Cartridge Low**, or **88 Black Cartridge low** appears, order a new cartridge.

When **88 Replace Cyan Cartridge**, **88 Replace Magenta Cartridge**, **88 Replace Yellow Cartridge**, or **88 Replace Black Cartridge** appears, you *must* replace the specified toner cartridge.

Part name	Part number	C540 and C543 series	C544 series
Black Return Program Toner Cartridge	C540A1KG	✓	✓
Cyan Return Program Toner Cartridge	C540A1CG	✓	✓
Magenta Return Program Toner Cartridge	C540A1MG	✓	✓
Yellow Return Program Toner Cartridge	C540A1YG	✓	✓
Black High Yield Return Program Toner Cartridge	C540H1KG	✓	✓
Cyan High Yield Return Program Toner Cartridge	C540H1CG	✓	✓
Magenta High Yield Return Program Toner Cartridge	C540H1MG	✓	✓
Yellow High Yield Return Program Toner Cartridge	C540H1YG	✓	✓
Black High Yield Toner Cartridge	C540H2KG	✓	✓
Cyan High Yield Toner Cartridge	C540H2CG	✓	✓
Magenta High Yield Toner Cartridge	C540H2MG	✓	✓

Part name	Part number	C540 and C543 series	C544 series
Yellow High Yield Toner Cartridge	C540H2YG	✓	✓
Black Extra High Yield Return Program Toner Cartridge	C544X1KG	Not supported	✓
Cyan Extra High Yield Return Program Toner Cartridge	C544X1CG	Not supported	✓
Magenta Extra High Yield Return Program Toner Cartridge	C544X1MG	Not supported	✓
Black Extra High Yield Toner Cartridge	C544X2KG	Not supported	✓
Cyan Extra High Yield Toner Cartridge	C544X2CG	Not supported	✓
Magenta Extra High Yield Toner Cartridge	C544X2MG	Not supported	✓
Yellow Extra High Yield Toner Cartridge	C544X2YG	Not supported	✓

Ordering imaging kits

When **Replace black and color imaging kit** or **Replace black imaging kit** appears, order a replacement imaging kit.

Part name	Part number
Black and Color Imaging Kit	C540X71G
Black Imaging Kit	C540X74G

Ordering a waste toner bottle

When **82 Replace Waste Toner** appears, order a replacement waste toner box. The waste toner box *must* be replaced when **82 Replace Waste Toner** appears.

Part name	Part number
Waste toner bottle	C540X75G

Replacing supplies

Replacing the waste toner bottle

Replace the waste toner bottle when 82 **Replace waste toner** appears. The printer will not continue printing until the waste toner bottle is replaced.

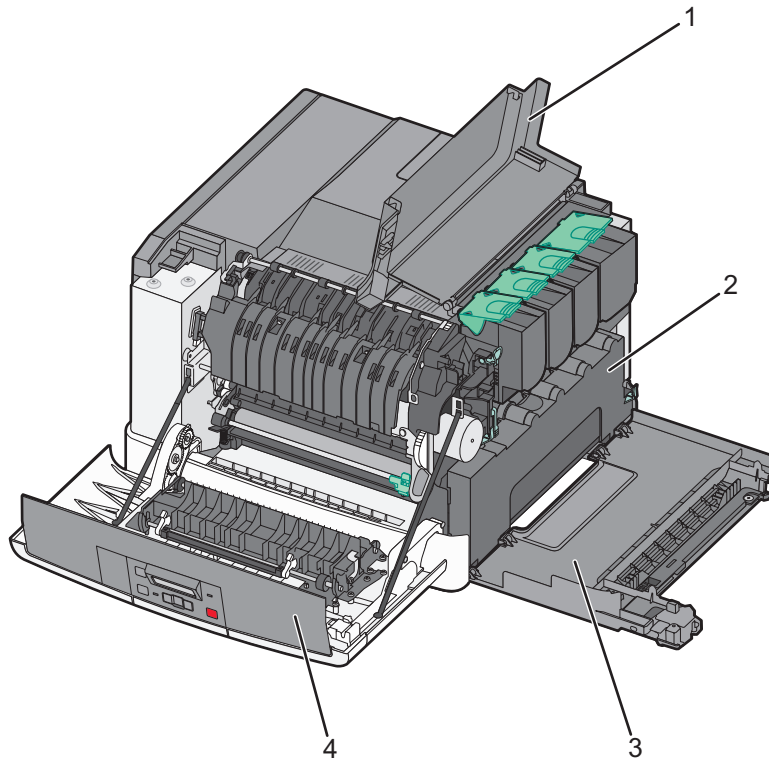

1	Top door
2	Waste toner bottle
3	Right side cover
4	Front door

- 1 Unpack the replacement waste toner bottle.
- 2 Grasp the front door at the side handholds, and then pull it toward you.



CAUTION—HOT SURFACE: The inside of the printer might be hot. To reduce the risk of injury from a hot component, allow the surface to cool before touching.

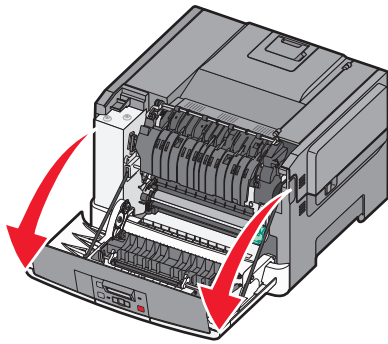

3 Open the top door.

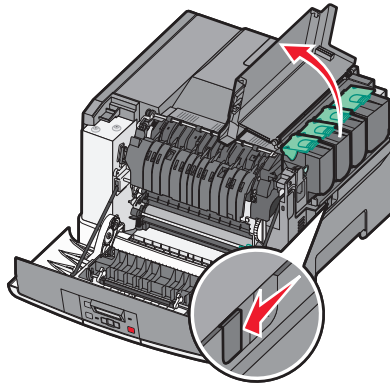

4 Remove the right side cover.

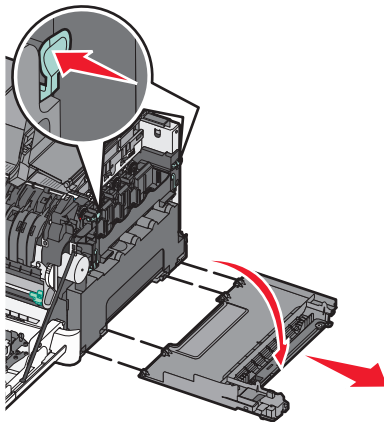

5 Press the green levers on each side of the waste toner bottle, and then remove it.

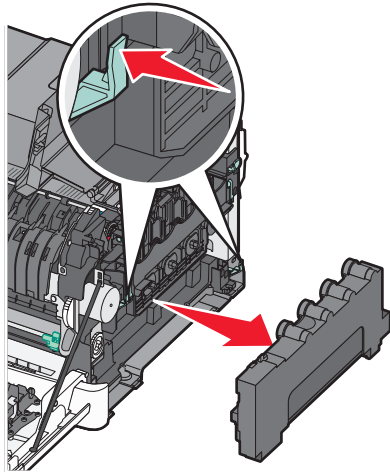

6 Place the waste toner bottle in the enclosed packaging. For more information, see “Recycling Lexmark products” on page 136.

7 Insert the new waste toner bottle.

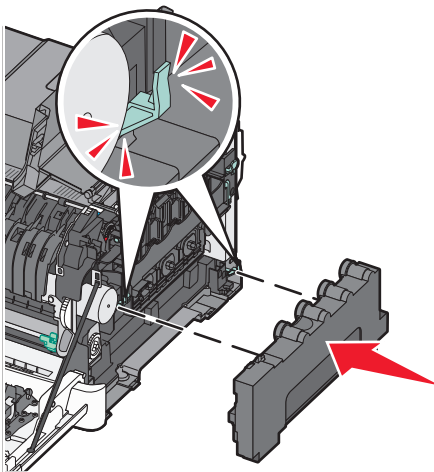

8 Replace the right side cover.

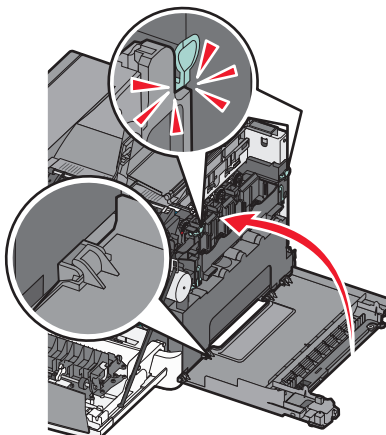

9 Close the top door.

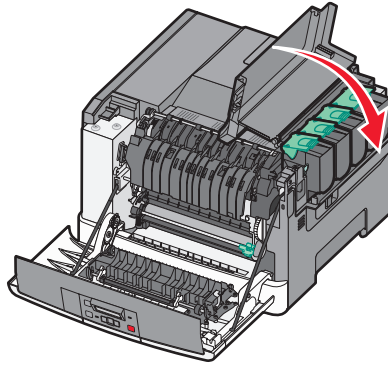

10 Close the front door.

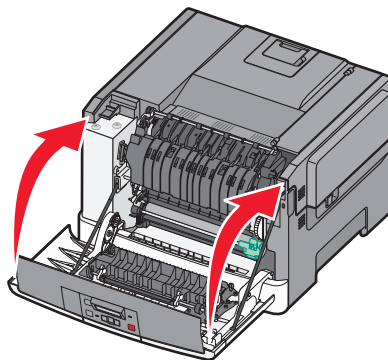

Replacing a black imaging kit

Replace the black imaging kit when **Imaging Kit** appears.

1 Grasp the front door at the side handholds, and then pull it toward you.

 **CAUTION—HOT SURFACE:** The inside of the printer might be hot. To reduce the risk of injury from a hot component, allow the surface to cool before touching.

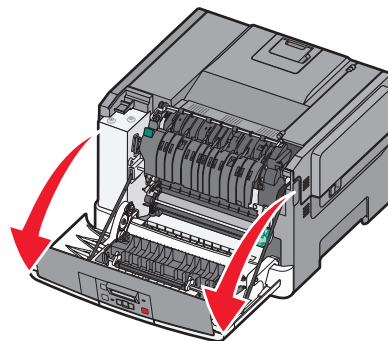

2 Open the top door.

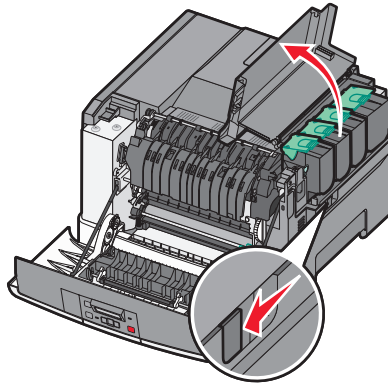

3 Remove the toner cartridges by lifting the handles, and then gently pulling away from the imaging kit.

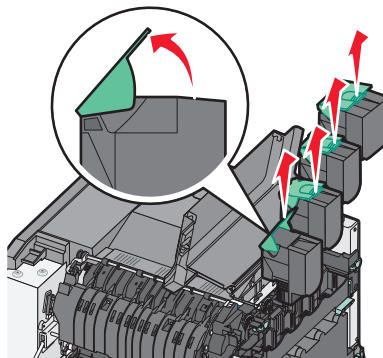

4 Remove the right side cover.

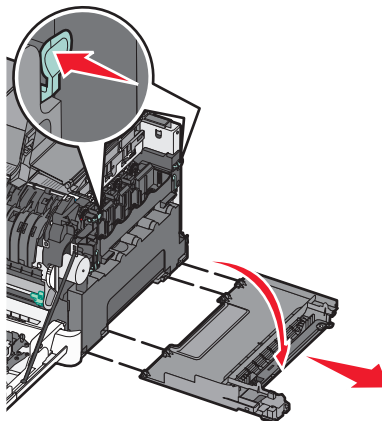

5 Press the green levers on each side of the waste toner bottle, and then remove it.

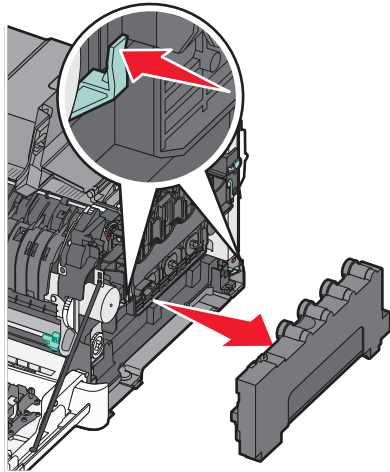

6 Lift the blue levers on the imaging kit, and then pull it toward you.

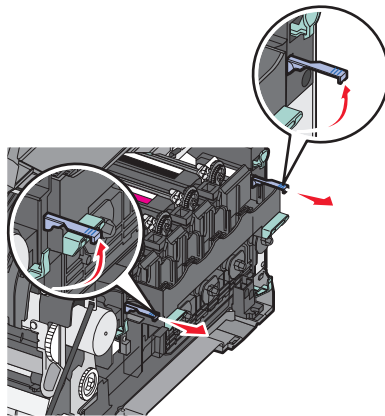

7 Press down on the blue levers, grasp the green handles on the sides, and then pull the imaging kit out.

Warning—Potential Damage: Do not touch the underside of the imaging kit. This could damage the imaging kit.

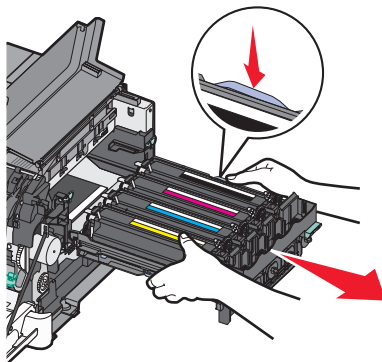

8 Remove the yellow, cyan, and magenta developer units.

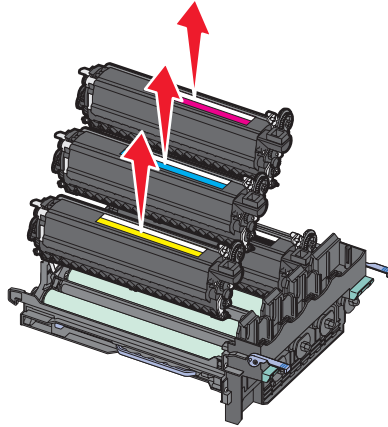

9 Unpack the replacement black imaging kit.
Leave the packaging on the black developer unit.

10 Gently shake the black developer unit side to side.

11 Remove the packaging from the black developer unit.

12 Insert the black developer unit.

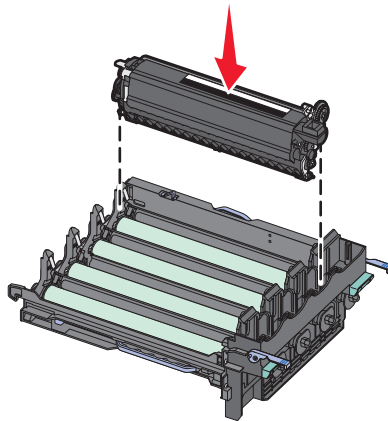

13 Replace the yellow, cyan, and magenta developer units.

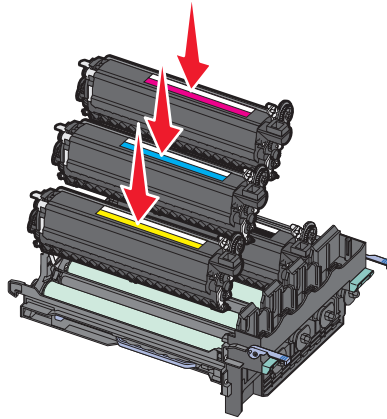

Note: Make sure each developer unit is inserted into a matching color slot.

14 Place the used black imaging kit in the enclosed package. For more information, see **Recycling Lexmark Products**.

15 Align and insert the imaging kit.

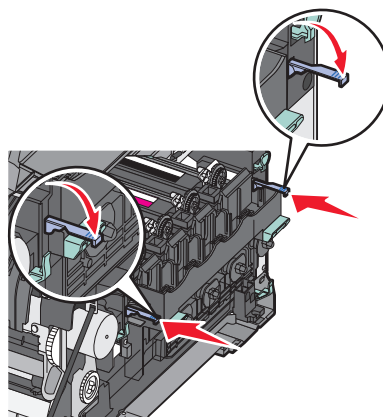
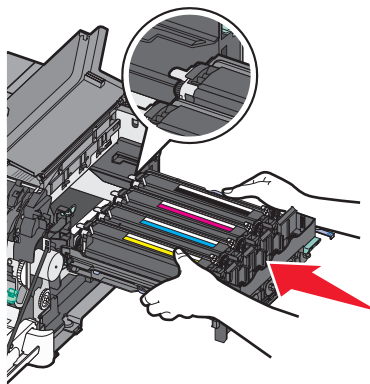

16 Rotate the blue levers down until the imaging kit drops into place.

17 Replace the waste toner bottle.

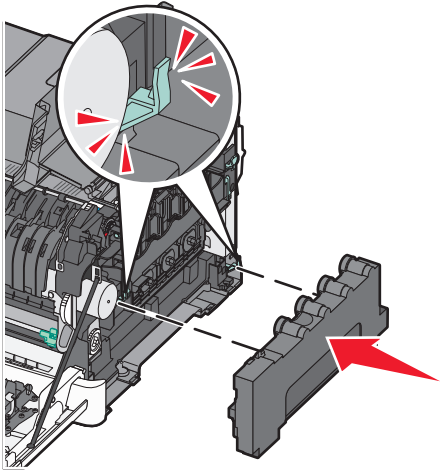

18 Replace the right side cover.

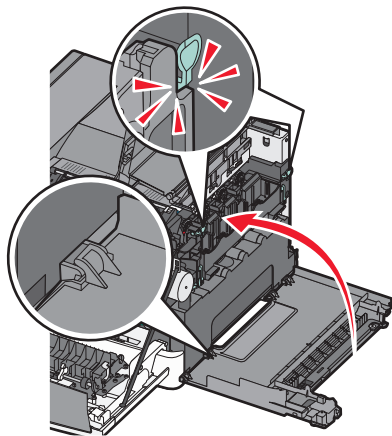

19 Replace the toner cartridges.

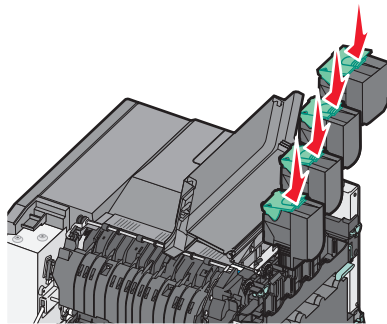

20 Close the top door.

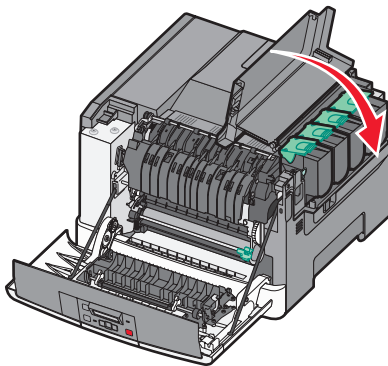

21 Close the front door.

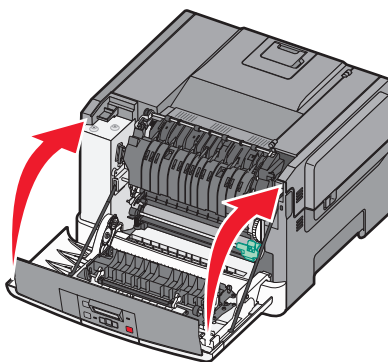

Replacing a black and color imaging kit

Replace the black and color imaging kit when **Imaging Kit** appears.

1 Grasp the front door at the side handholds, and then pull it toward you to open it.

 **CAUTION—HOT SURFACE:** The inside of the printer might be hot. To reduce the risk of injury from a hot component, allow the surface to cool before touching.

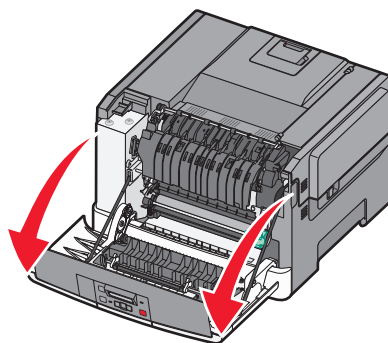

2 Open the top door.

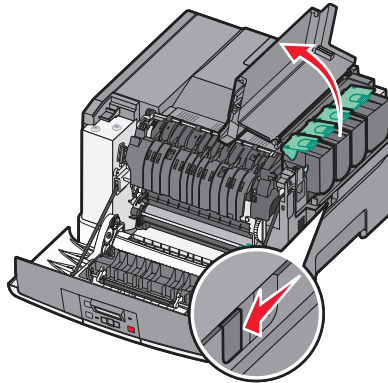

3 Remove the toner cartridges by lifting the handles, and then gently pulling away from the imaging kit.

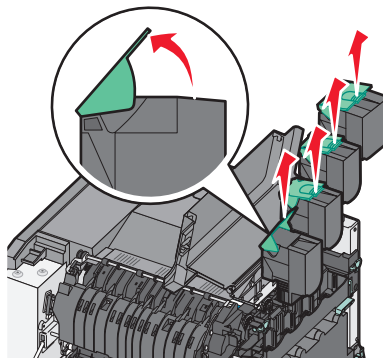

4 Remove the right side cover.

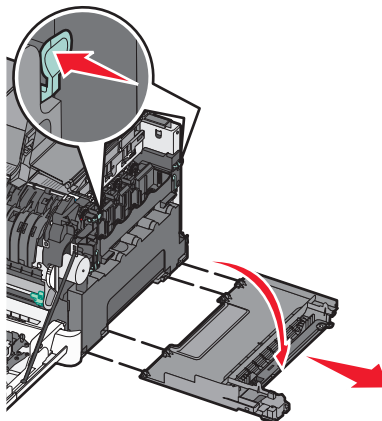

5 Press the green levers on each side of the waste toner bottle, and remove it.

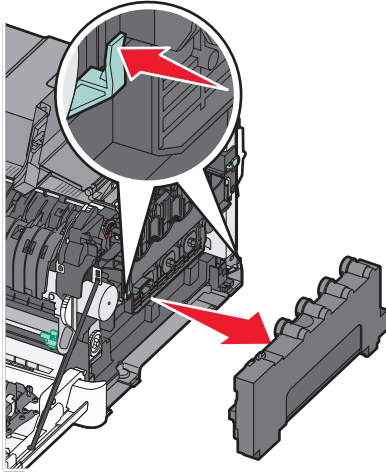

6 Lift the blue levers on the imaging kit, and then pull it toward you.

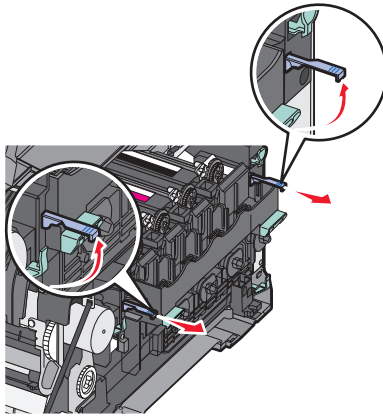

7 Press down on the blue levers, grasp the green handles on the sides, and then pull the imaging kit out.

Warning—Potential Damage: Do not touch the underside of the imaging kit. This could damage the imaging kit.

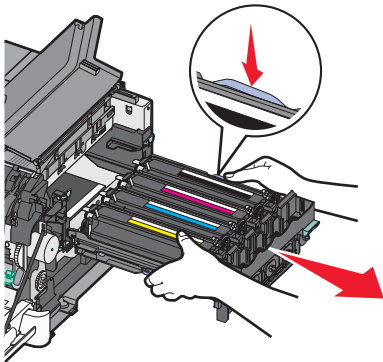

8 Unpack the replacement black and color imaging kit.

Leave the packaging on the developer units.

9 Gently shake the yellow, cyan, magenta, and black developer units side to side.

10 Remove the packaging from the yellow, cyan, magenta, and black developer units.

11 Insert the yellow, cyan, magenta, and black developer units.

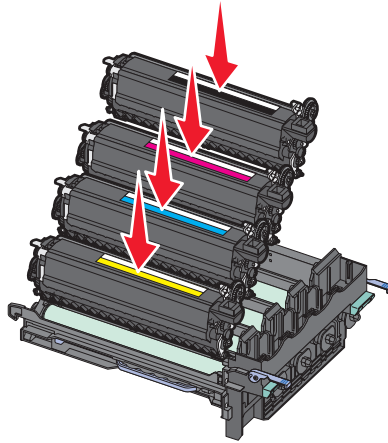

12 Place the used black and color imaging kit in the enclosed package. For more information, see "Recycling Lexmark products" on page 136.

13 Align and insert the imaging kit.

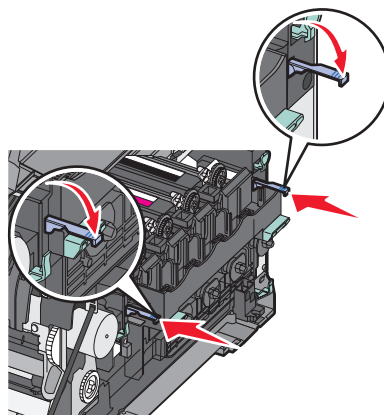
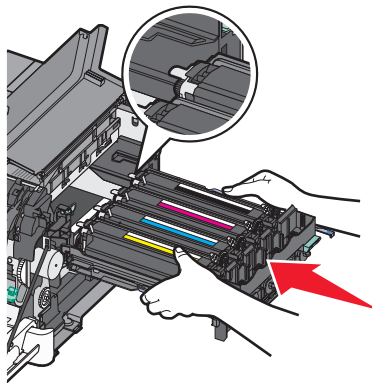

14 Replace the waste toner bottle.

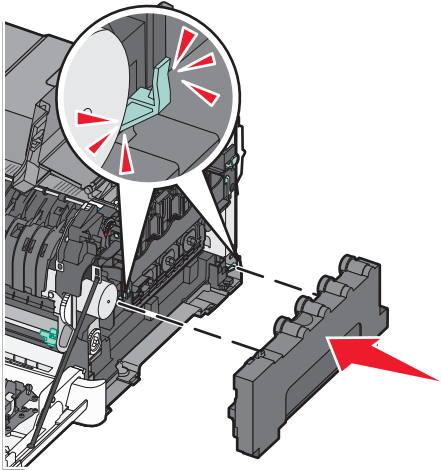

15 Replace the right side cover.

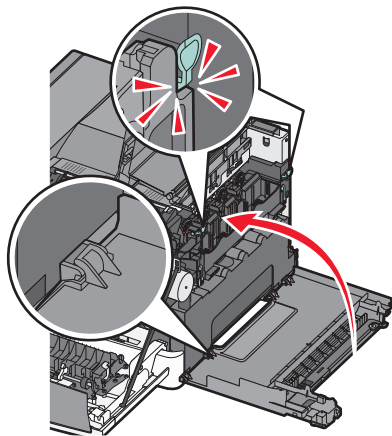

16 Replace the toner cartridges.

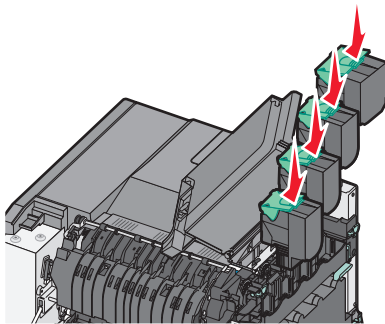

17 Close the top door.

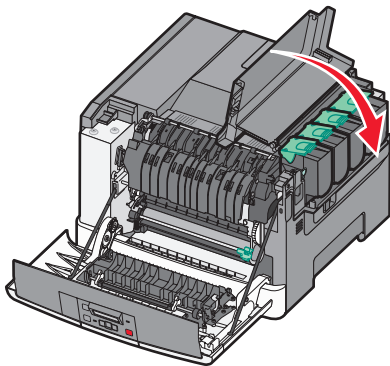

18 Close the front door.

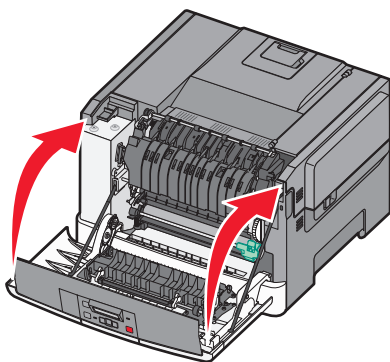

Replacing a toner cartridge

Replace the specified toner cartridge (yellow, cyan, magenta, or black) when **88 Replace <color> Cartridge** appears. The printer will not continue printing until the specified cartridge is replaced.

Warning—Potential Damage: Damage caused by use of a non-Lexmark toner cartridge is not covered under warranty.

Note: Degraded print quality may result from using non-Lexmark toner cartridges.

- 1 Make sure the printer is on and **Ready** or **88 Replace <color> Cartridge** appears.
- 2 Unpack the new cartridge, and set it near the printer.
- 3 Open the top door.

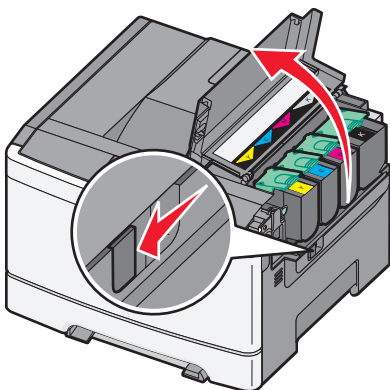

4 Remove the toner cartridge by lifting the handle, and then gently pulling away from the imaging kit.

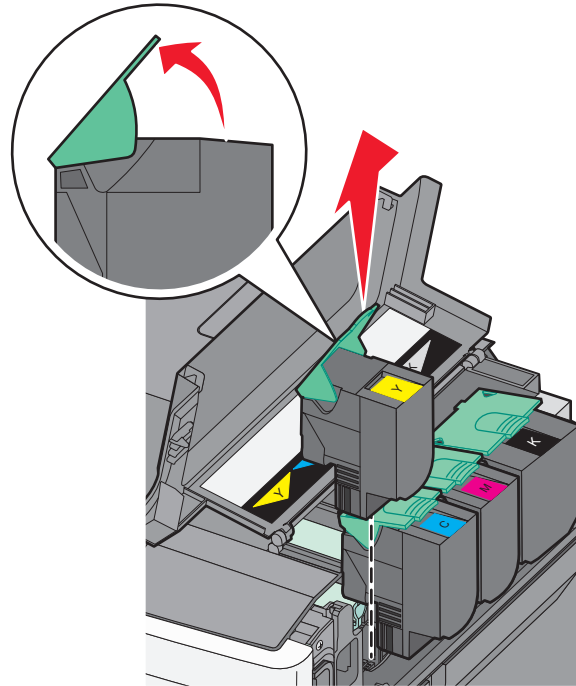

5 Align the new toner cartridge, and then press down until it is all the way into the slot.

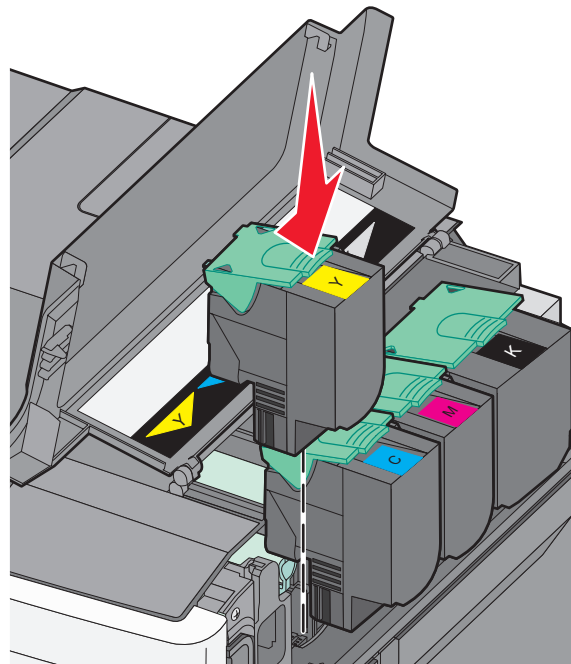

6 Close the top door.

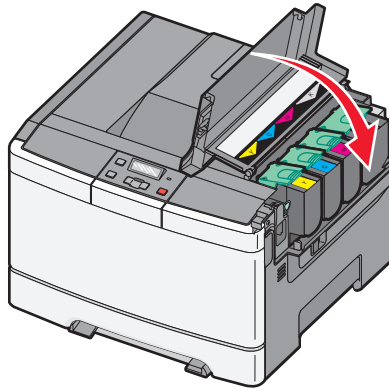

Replacing a developer unit

Replace a developer unit when a print quality defect occurs or when damage occurs to the printer.

Note: When a developer unit is replaced, you must manually calibrate the color. For more information, see “Color misregistration” on page 155.

1 Grasp the front door at the side handholds, and then pull it toward you to open it.

 **CAUTION—HOT SURFACE:** The inside of the printer might be hot. To reduce the risk of injury from a hot component, allow the surface to cool before touching.

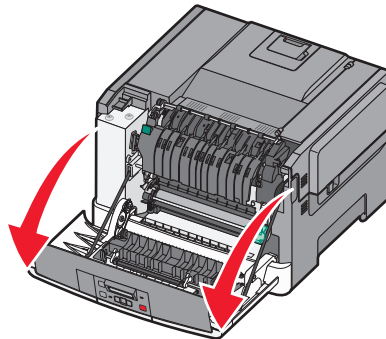

2 Open the top door.

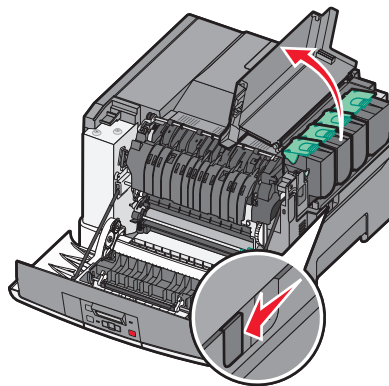

3 Remove the toner cartridges by lifting the handles and then gently pulling away from the imaging kit.

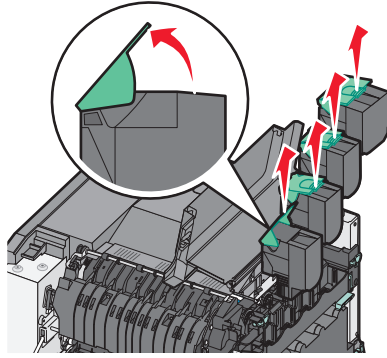

4 Remove the right side cover.

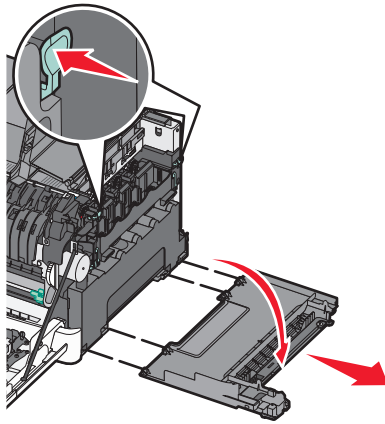

5 Press the green levers on each side of the waste toner bottle, and then remove it.

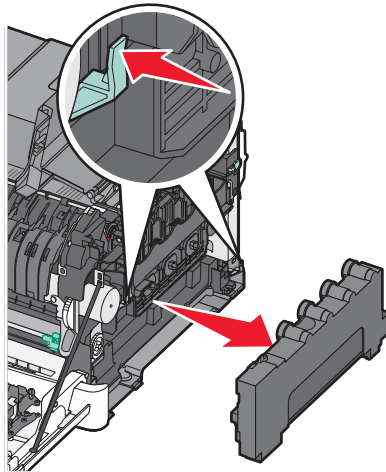

6 Lift the blue levers on the imaging kit, and then pull it toward you.

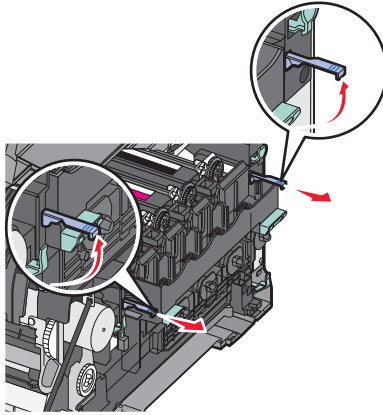

7 Press down on the blue levers, grasp the handles on the sides, and then pull the imaging kit out.

Warning—Potential Damage: Do not touch the underside of the imaging kit. This could damage the imaging kit.

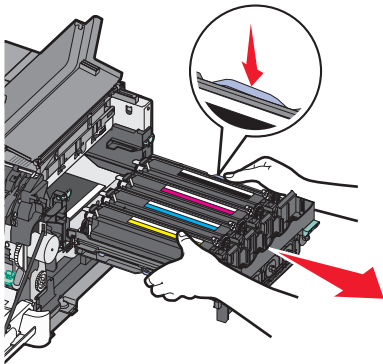

8 Remove the used developer unit.

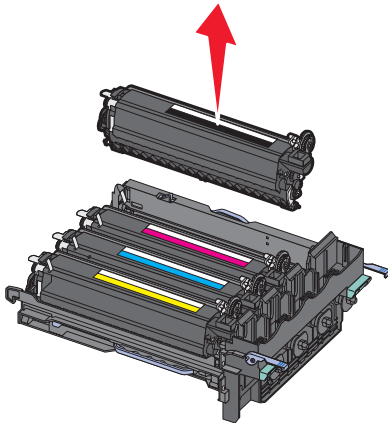

9 Place the used developer in the enclosed package. For more information, see “Recycling Lexmark products” on page 136.

10 Unpack the replacement developer unit.
Leave the packaging on the developer unit.

- 11 Gently shake the developer unit side to side.
- 12 Remove the red shipping cover from the developer unit.

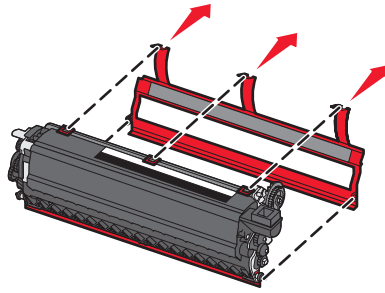

- 13 Insert the developer unit.

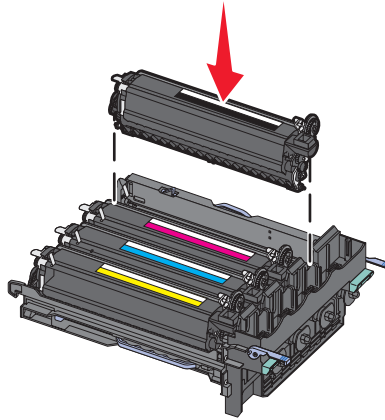

- 14 Align and insert the imaging kit.

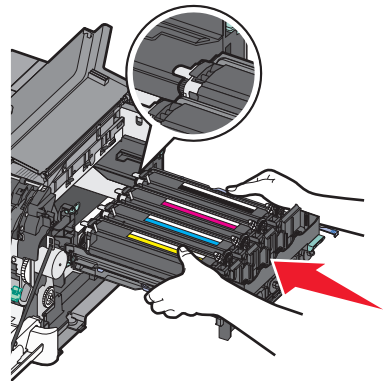

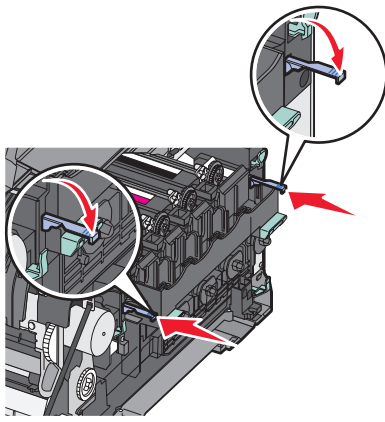

15 Replace the waste toner bottle.

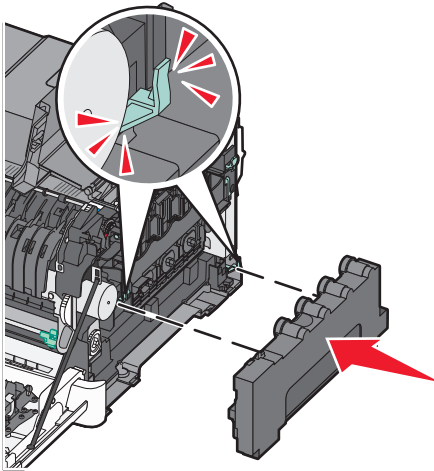

16 Replace the right side cover.

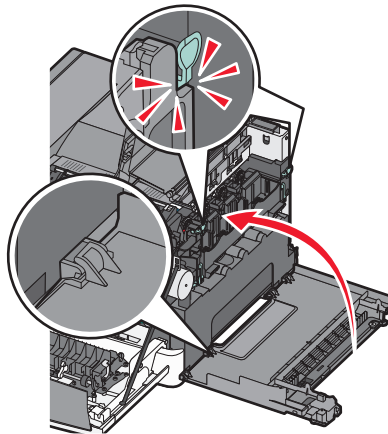

17 Replace the toner cartridges.

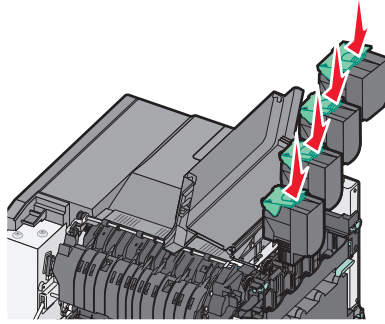

18 Close the top door.

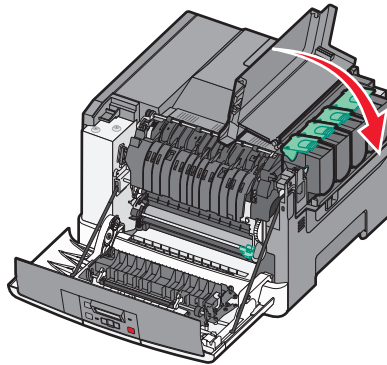

19 Close the front door.

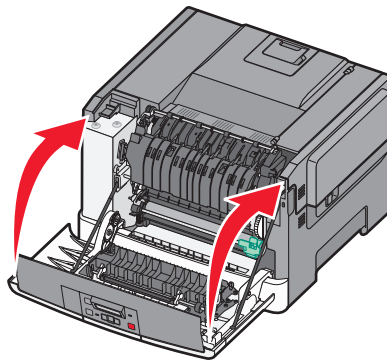

Cleaning the exterior of the printer

1 Make sure that the printer is turned off and unplugged from the wall outlet.

 **CAUTION—SHOCK HAZARD:** To avoid the risk of electric shock when cleaning the exterior of the printer, unplug the power cord from the wall outlet and disconnect all cables from the printer before proceeding.

2 Remove paper from the standard exit tray.

3 Dampen a clean, lint-free cloth with water.

Warning—Potential Damage: Do not use household cleaners or detergents, as they may damage the finish of the printer.

4 Wipe only the outside of the printer, making sure to include the standard exit tray.

Warning—Potential Damage: Using a damp cloth to clean the interior may cause damage to your printer.

5 Make sure the standard exit tray is dry before beginning a new print job.

Recycling Lexmark products

To return Lexmark products to Lexmark for recycling:

- 1 Visit our Web site at www.lexmark.com/recycle.
- 2 Find the product type you want to recycle, and then select your country from the list.
- 3 Follow the instructions on the computer screen.

Moving the printer

Before moving the printer



CAUTION—POTENTIAL INJURY: The printer weight is greater than 18 kg (40 lb) and requires two or more trained personnel to move it safely.



CAUTION—POTENTIAL INJURY: Before moving the printer, follow these guidelines to avoid personal injury or printer damage:

- Turn the printer off using the power switch, and then unplug the power cord from the wall outlet.
- Disconnect all cords and cables from the printer before moving it.
- Lift the printer off of the optional drawer and set it aside instead of trying to lift the drawer and printer at the same time.

Note: Use the handholds located on both sides of the printer to lift it off the optional drawer.

Warning—Potential Damage: Damage to the printer caused by improper moving is not covered by the printer warranty.

Moving the printer to another location

The printer and options can be safely moved to another location by following these precautions:

- Any cart used to move the printer must have a surface able to support the full footprint of the printer. Any cart used to move the options must have a surface able to support the dimensions of the options.
- Keep the printer in an upright position.
- Avoid severe jarring movements.







Shipping the printer

When shipping the printer, use the original packaging or call the place of purchase for a relocation kit.

Administrative support

Restoring the factory default settings









Menu settings marked with an asterisk (*) indicate the active settings. You can restore the original printer settings, often referred to as the *factory default settings*.

- 1 Make sure the printer is on and **Ready** appears.
- 2 From the printer control panel, press .
- 3 Press the arrow buttons until **Settings** appears, and then press .
- 4 Press the arrow buttons until **General Settings** appears, and then press .
- 5 Press the arrow buttons until **Factory Defaults** appears, and then press .
- 6 Press the arrow buttons until **Restore Now** appears, and then press .
Submitting changes appears briefly.
- 7 Press , and then press  until **Ready** appears.

The following factory default settings are restored:

- All downloaded resources in the printer memory are deleted. This includes fonts, macros, and symbol sets.
- All settings return to the factory default settings except **Printer Language** in the Setup menu and custom settings in the Network and USB menus.

Adjusting Power Saver

- 1 Make sure the printer is on and **Ready** appears.
- 2 From the printer control panel, press .
- 3 Press the arrow buttons until **Settings** appears, and then press .
- 4 Press the arrow buttons until **General Settings** appears, and then press .
- 5 Press the arrow buttons until **Timeout** appears, and then press .
- 6 Press the arrow buttons until **Power Saver** appears, and then press .
- 7 Press the arrow buttons to enter the number of minutes for the printer to wait before entering the Power Saver mode. Available settings range from 1–240 minutes.
- 8 Press .
- Submitting changes** appears.
- 9 Press , and then press  until **Ready** appears.

Note: Power Saver settings can also be adjusted by typing the printer IP address into the address field of your Web browser.

Using the Embedded Web Server

If the printer is installed on a network, the Embedded Web Server is available for a range of functions:

- Configuring printer settings
- Checking the status of the printer supplies
- Configuring network settings
- Viewing reports
- Restoring the factory default settings
- Viewing the virtual display
- Setting Web page password protect
- Setting Panel PIN protect
- Setting the date and time

To access the Embedded Web Server:

- 1 Type the printer IP address into the address field of your Web browser.

Note: If you do not know the IP address of the printer, then print a network setup page and locate the IP address in the TCP/IP section.

- 2 Click one of the tabs to access information about the printer, change settings, or view a report.

Note: If the printer is connected to a computer by a USB or parallel cable, then open the Local Printer Settings Utility for Windows or Printer Settings for Macintosh to access printer menus.

Setting up e-mail alerts

You can have the printer send you an e-mail when the supplies are getting low or when the paper needs to be changed, added, or unjammed.

To set up e-mail alerts:

- 1 Type the printer IP address into the address field of your Web browser.

Note: If you do not know the IP address of the printer, then print a network setup page and locate the IP address in the TCP/IP section.

- 2 Click **Settings**.

- 3 Under Other Settings, click **E-mail Alert Setup**.

- 4 Select the items for notification and type in the e-mail addresses that you want to receive e-mail alerts.

- 5 Click **Submit**.

Note: See your system support person to set up the e-mail server.

Configuring supply notifications

You can determine how you would like to be notified when supplies run low or reach their end-of-life.

To configure supply notifications using the Embedded Web Server:

- 1 Type the printer IP address into the address field of your Web browser.
Note: If you do not know the IP address of the printer, then print a network setup page and locate the IP address in the TCP/IP section.
- 2 Click **Settings**.
- 3 Click **Print Settings**.
- 4 Click **Supply Notifications**.
- 5 From the drop-down box for each supply, select among the options for notification. Explanations for each option are provided.
- 6 Click **Submit** to save your selections.

Copying printer settings to other printers

Using the Embedded Web Server, you can copy printer settings to up to 15 other network printers. To copy printer settings:

- 1 Type the printer IP address into the address field of your Web browser.
Note: If you do not know the IP address of the printer, then print a network setup page and locate the IP address in the TCP/IP section.
- 2 Click **Copy Printer Settings**.
- 3 To change the language, select a language from the drop-down list, and then click **Click here to submit language**.
- 4 Click **Printer Settings**.
- 5 Enter the IP addresses of the source and target printers.
Note: To add additional target printers, click the **Add Target IP** button.
- 6 Click **Copy Printer Settings**.

Troubleshooting

Solving basic printer problems

If there are basic printer problems, or the printer is unresponsive, make sure:

- The power cord is plugged into the printer and a properly grounded electrical outlet.
- The electrical outlet is not turned off by any switch or breaker.
- The printer is not plugged into any surge protectors, uninterrupted power supplies, or extension cords.
- Other electronic equipment plugged into the outlet is working.
- The printer is turned on. Check the printer power switch.
- The printer cable is securely attached to the printer and the host computer, print server, option, or other network device.
- All options are properly installed.
- The printer driver settings are correct.

Once you have checked each of these possibilities, turn the printer off, wait for about 10 seconds, and then turn the printer back on. This often fixes the problem.

Solving printing problems

Printer control panel display is blank or displays only diamonds

The printer self test failed. Turn the printer off, wait about 10 seconds, and then turn the printer back on.

If **Ready** does not appear, turn the printer off and contact Customer Support.

Error message about reading USB drive appears

Make sure the USB drive is supported. For information regarding tested and approved USB flash memory devices, visit the Lexmark Web site at www.lexmark.com.

Jobs do not print

These are possible solutions. Try one or more of the following:

MAKE SURE THE PRINTER IS READY TO PRINT

Make sure **Ready** or **Power Saver** appears on the display before sending a job to print. Press  to return the printer to the **Ready** state.

CHECK TO SEE IF THE STANDARD EXIT BIN IS FULL

Remove the stack of paper from the standard exit bin.

CHECK TO SEE IF THE PAPER TRAY IS EMPTY

Load paper in the tray.

MAKE SURE THE CORRECT PRINTER SOFTWARE IS INSTALLED

- Verify that you are using the correct printer software.
- If you are using a USB port, make sure you are running a supported operating system and using compatible printer software.

MAKE SURE YOU ARE USING A RECOMMENDED USB, SERIAL, OR ETHERNET CABLE

For more information, visit the Lexmark Web site at www.lexmark.com.

MAKE SURE PRINTER CABLES ARE SECURELY CONNECTED

Check the cable connections to the printer and print server to make sure they are secure.

For more information, see the setup documentation that came with the printer.







Job takes longer than expected to print

These are possible solutions. Try one or more of the following:

REDUCE THE COMPLEXITY OF THE PRINT JOB

Eliminate the number and size of fonts, the number and complexity of images, and the number of pages in the job.

CHANGE THE PAGE PROTECT SETTING TO OFF

- 1 From the printer control panel, press .
- 2 Press the arrow buttons until **Settings** appears, and then press .
- 3 Press the arrow buttons until **Setup Menu** appears, and then press .
- 4 Press the arrow buttons until **Print Recovery** appears, and then press .
- 5 Press the arrow buttons until **Page Protect** appears, and then press .
- 6 Press the arrow buttons until **Off** appears, and then press .

Job prints from the wrong tray or on the wrong paper

CHECK THE PAPER TYPE SETTING

Make sure the Paper Type setting matches the paper loaded in the tray.

Incorrect characters print

Make sure the printer is not in Hex Trace mode. If **Ready Hex** appears on the display, you must exit Hex Trace mode before you can print your job. Turn the printer off and back on to exit Hex Trace mode.

Tray linking does not work

These are possible solutions. Try one or more of the following:

LOAD THE SAME SIZE AND TYPE OF PAPER

- Load the same size and type of paper in each tray to be linked.
- Move the paper guides to the correct positions for the paper size loaded in each tray.

USE THE SAME PAPER SIZE AND PAPER TYPE SETTINGS

- Print a menu settings page and compare the settings for each tray.
- If necessary, adjust the settings from the Paper Size/Type menu.

Note: The multipurpose feeder does not automatically sense the paper size. You must set the size from the Paper Size/Type menu.

Large jobs do not collate

These are possible solutions. Try one or more of the following:

MAKE SURE COLLATE IS SET TO ON

From the printer control panel Finishing menu, Print Properties, or the Print dialog, set Collate to On.

Note: Setting Collate to Off in the software overrides the setting in the Finishing menu.

REDUCE THE COMPLEXITY OF THE PRINT JOB







Reduce the complexity of the print job by eliminating the number and size of fonts, the number and complexity of images, and the number of pages in the job.

MAKE SURE THE PRINTER HAS ENOUGH MEMORY

Add printer memory.

Unexpected page breaks occur

Increase the Print Timeout value:

- 1 From the printer control panel, press .
- 2 Press the arrow buttons until **Settings** appears, and then press .
- 3 Press the arrow buttons until **General Settings** appears, and then press .
- 4 Press the arrow buttons until **Timeouts** appears, and then press .
- 5 Press the arrow buttons until **Print Timeout** appears, and then press .
- 6 Press the arrow buttons until the desired value appears, and then press .

Solving option problems

Option does not operate correctly or quits after it is installed

These are possible solutions. Try one or more of the following:

RESET THE PRINTER

Turn the printer off, wait about 10 seconds, and then turn the printer on.

CHECK TO SEE IF THE OPTION IS CONNECTED TO THE PRINTER

- 1 Turn the printer off.
- 2 Unplug the printer.
- 3 Check the connection between the option and the printer.

MAKE SURE THE OPTION IS INSTALLED CORRECTLY

Print a menu settings page and check to see if the option is listed in the Installed Options list. If the option is not listed, then reinstall it. For more information, see the hardware setup documentation that came with the option, or go to www.lexmark.com/publications to view the option instruction sheet.

MAKE SURE THE OPTION IS SELECTED

From the computer you are printing from, select the option. For more information, see “Updating available options in the printer driver” on page 27.

Drawers

MAKE SURE THE PAPER IS LOADED CORRECTLY

- 1 Open the paper tray.
- 2 Check for paper jams or misfeeds.
- 3 Make sure paper guides are aligned against the edges of the paper.
- 4 Make sure the paper tray closes properly.
- 5 Close the door.

RESET THE PRINTER

Turn the printer off. Wait 10 seconds. Turn the printer back on.

Flash memory card

Make sure the flash memory card is securely connected to the printer system board.

Multipurpose feeder

CHECK THE MULTIPURPOSE FEEDER

Make sure the 650-sheet duo drawer (multipurpose feeder) is installed properly.

CLEAR ANY JAMS

Clear any jams in the multipurpose feeder.

CHECK THE POWER CORD CONNECTION

Make sure:

- The power cord is plugged into the printer and a properly grounded electrical outlet.
- The outlet has power.

CHECK THE PAPER

Use recommended paper and specialty media. For more information, see the chapter about paper and specialty media guidelines.

CHECK THE PAPER GUIDES

Move the guides in the tray to the correct position for the size loaded.

CHECK FOR SERVICE MESSAGES

If a service message appears, turn the printer off, wait about 10 seconds, and then turn the printer back on. If the error recurs, call for service.

Memory card

Make sure the memory card is securely connected to the printer system board.

Solving paper feed problems

Paper frequently jams

These are possible solutions. Try one or more of the following:

CHECK THE PAPER

Use recommended paper and specialty media. For more information, see the chapter about paper and specialty media guidelines.

MAKE SURE THERE IS NOT TOO MUCH PAPER IN THE PAPER TRAY

Make sure the stack of paper you load does not exceed the maximum stack height indicated in the tray or on the multipurpose feeder.

CHECK THE PAPER GUIDES

Move the guides in the tray to the correct positions for the paper size loaded.

THE PAPER MAY HAVE ABSORBED MOISTURE DUE TO HIGH HUMIDITY







- Load paper from a fresh package.
- Store paper in its original wrapper until you use it.

Paper jam message remains after jam is cleared

The paper path is not clear. Clear jammed paper from the entire paper path, and then press .

Page that jammed does not reprint after you clear the jam

In the Setup menu, Jam Recovery is set to Off. Set Jam Recovery to Auto or On:

- 1 Press .
- 2 Press the arrow buttons until **Settings** appears, and then press .
- 3 Press the arrow buttons until **General settings** appears, and then press .
- 4 Press the arrow buttons until **Print Recovery** appears, and then press .
- 5 Press the arrow buttons until **Jam Recovery** appears, and then press .
- 6 Press the arrow buttons until **On** or **Auto** appears, and then press .

Solving print quality problems

The information in the following topics may help you solve print quality problems. If these suggestions do not correct the problem, contact Customer Support. You may have a printer part that requires adjustment or replacement.

Isolating print quality problems

To help isolate print quality problems, print the print quality test pages:

- 1 Turn the printer off.
- 2 Load letter- or A4-size paper.

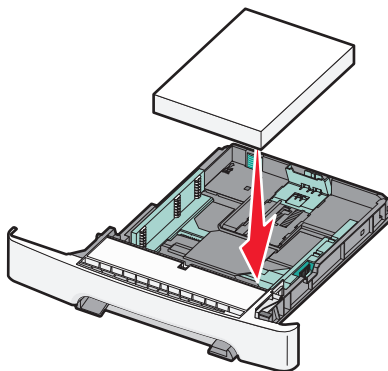

- 3 From the printer control panel, press and hold and the right arrow button while turning the printer on.
- 4 Release both buttons when **Performing Self Test** appears.
The printer performs its power-on sequence, and then **Config Menu** appears.
- 5 Press the arrow buttons until **Prt Quality Pgs** appears, and then press .
The pages are formatted. **Printing Quality Test Pages** appears, and then the pages print. The message remains on the display until all the pages print.
- 6 After the print quality test pages print, press the arrow buttons until **Exit Config Menu** appears, and then press .

Blank pages

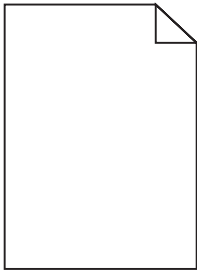

The printer may need to be serviced. For more information, contact Customer Support.

Characters have jagged or uneven edges

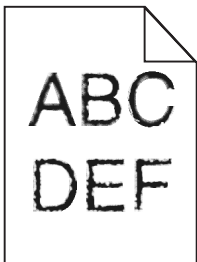

These are possible solutions. Try one or more of the following:

CHECK THE PRINT QUALITY SETTINGS

- Change the Print Resolution setting in the Quality menu to 600 dpi, 1200 Image Q, 1200 dpi, or 2400 Image Q.
- Enable Enhance Fine Lines in the Quality menu.

MAKE SURE DOWNLOADED FONTS ARE SUPPORTED

If you are using downloaded fonts, then verify that the fonts are supported by the printer, the host computer, and the software program.

Clipped images

These are possible solutions. Try one or more of the following:

CHECK THE GUIDES

Move the width and length guides in the tray to the correct positions for the paper size loaded.

CHECK THE PAPER SIZE SETTING

Make sure the paper size setting matches the paper loaded in the tray:

- 1 From the printer control panel, check the Paper Size setting from the Paper menu.
- 2 Before sending the job to print, specify the correct size setting:
 - For Windows users, specify the size from Print Properties.
 - For Macintosh users, specify the size from the Page Setup dialog.

Dark lines

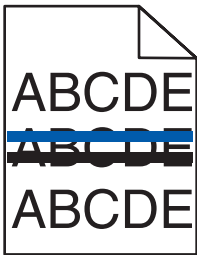

The imaging kit may be defective.

If **Black and color imaging kit life warning** or **Black imaging kit life warning** appears, replace the imaging kit.

Gray background

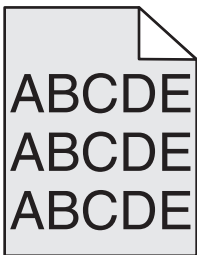

CHECK THE TONER DARKNESS SETTING

Select a lighter Toner Darkness setting:

- From the printer control panel, change the setting from the Quality menu.
- For Windows users, change the setting from Print Properties.
- For Macintosh users, change the setting from the Print dialog.

Incorrect margins

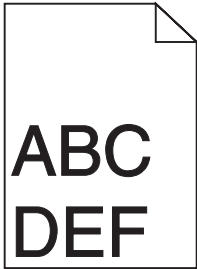

CHECK THE PAPER GUIDES

Move the guides in the tray to the correct positions for the paper size loaded.

CHECK THE PAPER SIZE SETTING

Make sure the paper size setting matches the paper loaded in the tray:

- 1 From the printer control panel, check the Paper Size setting from the Paper menu.
- 2 Before sending the job to print, specify the correct size setting:
 - For Windows users, specify the size from Print Properties.
 - For Macintosh users, specify the size from the Page Setup dialog.

CHECK THE PAGE SIZE SETTING

Before sending the job to print, specify the correct page size in the Print dialog or the software program.

Light colored line, white line, or incorrectly colored line

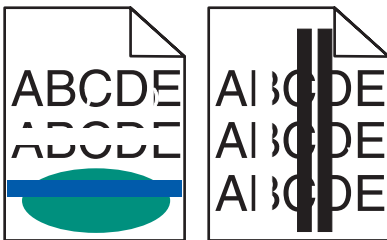

These are possible solutions. Try one or more of the following:

A TONER CARTRIDGE MAY BE DEFECTIVE

Replace the defective toner cartridge.

THE IMAGING KIT MAY BE DEFECTIVE

Replace the imaging kit.

Note: The printer has two types of imaging kits: a black and color imaging kit, and a black imaging kit. The black and color imaging kit contains cyan, magenta, yellow, and black. The black imaging kit contains black only.

Paper curl

These are possible solutions. Try one or more of the following:

CHECK THE PAPER TYPE SETTING

Make sure the Paper Type setting matches the paper loaded in the tray.

HAS THE PAPER ABSORBED MOISTURE DUE TO HIGH HUMIDITY?

- Load paper from a fresh package.
- Store paper in its original wrapper until you use it.

Print irregularities

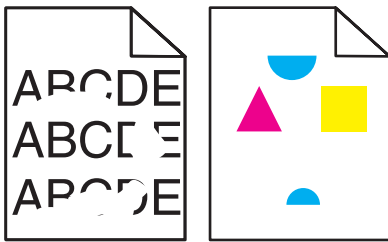

These are possible solutions. Try one or more of the following:

THE PAPER MAY HAVE ABSORBED MOISTURE DUE TO HIGH HUMIDITY

- Load paper from a fresh package.
- Store paper in its original wrapper until you use it.

CHECK THE PAPER TYPE SETTING

Make sure the Paper Type setting matches the paper loaded in the tray.

CHECK THE PAPER

Avoid textured paper with rough finishes.

THE TONER MAY BE LOW

When 88 <color> cartridge low appears, order a new cartridge.



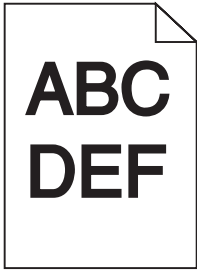

Print is too dark



These are possible solutions. Try one or more of the following:

CALIBRATE THE COLOR

The printer automatically calibrates the colors whenever a new imaging kit is detected. If a cartridge is replaced, then you can calibrate the colors manually:

- 1 From the printer control panel, press .
 - 2 From the **Admin** menu, press the arrow buttons until **Settings** appears, and then press .
 - 3 Press the arrow buttons until **Quality** menu appears, and then press .
 - 4 Press the arrow buttons until **Color Adjust** appears, and then press .
- Calibrating** appears.

CHECK THE DARKNESS, BRIGHTNESS, AND CONTRAST SETTINGS

The Toner Darkness setting is too dark, the RGB Brightness setting is too dark, or the RGB Contrast setting is too high.

- For Windows users: from Print Properties, select **Print Quality** and then select **More Print Quality Options** to change these settings.
- From the printer control panel Quality menu, change these settings.
- For Macintosh users:
 - 1 Choose **File > Print**.
 - 2 Locate the drop-down box under the Orientation pictures, and then click the down button.
 - 3 Click **Printer Features**.
 - 4 Change the settings for Toner Darkness, Brightness, and Contrast.

THE IMAGING KIT MAY BE WORN OR DEFECTIVE

Replace the imaging kit.

Note: The printer has two types of imaging kits: a black and color imaging kit, and a black imaging kit. The black and color imaging kit contains cyan, magenta, yellow, and black. The black imaging kit contains black only.



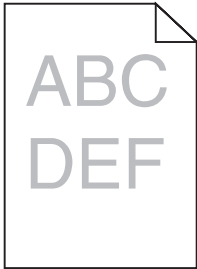

Print is too light



These are possible solutions. Try one or more of the following:

CALIBRATE THE COLOR

The printer will automatically calibrate the colors whenever a new imaging kit is detected. If a cartridge is replaced, then you can calibrate the colors manually:

- 1 From the printer control panel, press .
 - 2 From the **Admin** menu, press the arrow buttons until **Settings** appears, and then press .
 - 3 Press the arrow buttons until **Quality** menu appears, and then press .
 - 4 Press the arrow buttons until **Color Adjust** appears, and then press .
- Calibrating** appears.

CHECK THE DARKNESS, BRIGHTNESS, AND CONTRAST SETTINGS

The Toner Darkness setting is too light, the RGB Brightness setting is too light, or the RGB Contrast setting is too low.

- For Windows users: from Print Properties, select **Print Quality** and then select **More Print Quality Options** to change these settings.
- For Macintosh users:
 - 1 Choose **File > Print**.
 - 2 Locate the drop-down box under the Orientation pictures, and then click the down button.
 - 3 Click **Printer Features**.
 - 4 Change the settings for Toner Darkness, Brightness, and Contrast.
- From the printer control panel Quality menu, change these settings.

THE PAPER MAY HAVE ABSORBED MOISTURE DUE TO HIGH HUMIDITY

- Load paper from a fresh package.
- Store paper in its original wrapper until you use it.

CHECK THE PAPER

Avoid textured paper with rough finishes.

CHECK THE PAPER TYPE SETTING

Make sure the Paper Type setting matches the paper loaded in the tray.

MAKE SURE COLOR SAVER IS SET TO OFF

Color Saver may be set to On.

THE TONER MAY BE LOW

When 88 <color> Cartridge Low appears, order a new cartridge.

A TONER CARTRIDGE MAY BE DEFECTIVE

Replace the toner cartridge.

THE IMAGING KIT MAY BE WORN OR DEFECTIVE

Replace the imaging kit.

Note: The printer has two types of imaging kits: a black and color imaging kit, and a black imaging kit. The black and color imaging kit contains cyan, magenta, yellow, and black. The black imaging kit contains black only.

Repeating defects

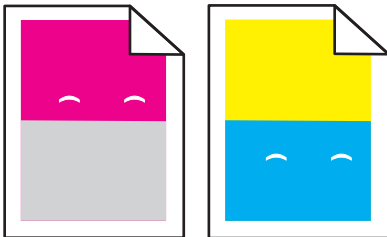

REPEATING MARKS OCCUR REPEATEDLY ONLY IN ONE COLOR AND MULTIPLE TIMES ON A PAGE

Replace the developer unit if the defects occur every 43.9 mm (1.7 in.)

Replace the imaging kit if the defects occur every:

- 34.6 mm (1.4 in.)
- 94.2 mm (3.71 in.)

Notes:

- The printer has two types of imaging kits: a black and color imaging kit, and a black imaging kit. The black and color imaging kit contains cyan, magenta, yellow, and black. The black imaging kit contains black only.
- The Print Defects menu prints a diagnostic list of problems. For more information, see “Menu Settings Page menu” on page 81.

Skewed print

CHECK THE PAPER GUIDES

Move the guides in the tray to the correct positions for the paper size loaded.

CHECK THE PAPER

Make sure you are using paper that meets the printer specifications.

Solid color pages

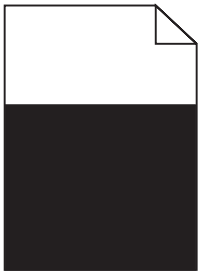

The printer may need to be serviced. For more information, contact Customer Support.

Toner fog or background shading appears on the page

These are possible solutions. Try one or more of the following:

THE IMAGING KIT MAY BE WORN OR DEFECTIVE

Replace the imaging kit.

Note: The printer has two types of imaging kits: a black and color imaging kit, and a black imaging kit. The black and color imaging kit contains cyan, magenta, yellow, and black. The black imaging kit contains black only.

IS THERE TONER IN THE PAPER PATH?

Contact Customer Support.

Toner rubs off

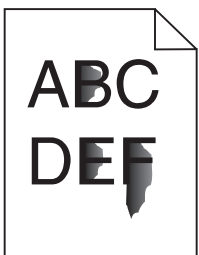

These are possible solutions. Try one or more of the following:

CHECK THE PAPER TYPE SETTING

Make sure the paper type setting matches the paper loaded in the tray:

- 1 From the printer control panel, check the Paper Type setting from the Paper menu.
- 2 Before sending the job to print, specify the correct type setting:
 - For Windows users, specify the type from Print Properties.
 - For Macintosh users, specify the type from the Print dialog.

CHECK THE PAPER TEXTURE SETTING

From the printer control panel Paper menu, make sure the Paper Texture setting matches the paper loaded in the tray.

Toner specks

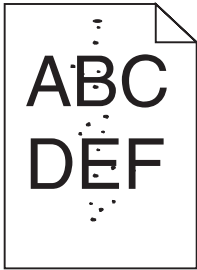

These are possible solutions. Try one or more of the following:

THE IMAGING KIT MAY BE WORN OR DEFECTIVE

Replace the imaging kit.

Note: The printer has two types of imaging kits: a black and color imaging kit, and a black imaging kit. The black and color imaging kit contains cyan, magenta, yellow, and black. The black imaging kit contains black only.

IS THERE TONER IN THE PAPER PATH?

Contact Customer Support.

Transparency print quality is poor

CHECK THE TRANSPARENCIES

Use only transparencies recommended by the printer manufacturer.

CHECK THE PAPER TYPE SETTING

Make sure the paper type setting matches the paper loaded in the tray:

- 1 From the printer control panel, check the Paper Type setting from the Paper menu.
- 2 Before sending the job to print, specify the correct type setting:
 - For Windows users, specify the type from Print Properties.
 - For Macintosh users, specify the type from the Print dialog.

Uneven print density

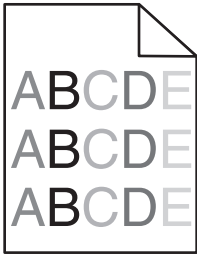

Replace the black and color imaging kit.

Solving color quality problems

This section helps answer some basic color-related questions and describes how some of the features provided in the printer control panel Quality menu can be used to solve typical color problems.

Color misregistration

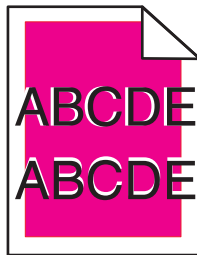

Color has shifted outside of the appropriate area or has been superimposed over another color area.





These are possible solutions. Try one or more of the following:

REMOVE AND REINSTALL THE TONER CARTRIDGES

Remove the toner cartridges, and then reinstall them.

CALIBRATE THE COLOR

The printer will automatically calibrate the color whenever a new imaging kit is detected.

- 1 From the printer control panel, press .
 - 2 From the Setting/Quality menu, press the arrow buttons until **Color Adj Setting Text** appears, and then press .
 - 3 Press the arrow buttons until **Quality menu** appears, and then press .
 - 4 Press the arrow buttons until **Color Adjust** appears, and then press .
- Calibrating** appears.

Note: If you have not resolved the issue, calibrate the color again.

FAQ about color printing

What is RGB color?

Red, green, and blue light can be added together in various amounts to produce a large range of colors observed in nature. For example, red and green can be combined to create yellow. Televisions and computer monitors create colors in this manner. RGB color is a method of describing colors by indicating the amount of red, green, or blue needed to produce a certain color.

What is CMYK color?

Cyan, magenta, yellow, and black inks or toners can be printed in various amounts to produce a large range of colors observed in nature. For example, cyan and yellow can be combined to create green. Printing presses, inkjet printers, and color laser printers create colors in this manner. CMYK color is a method of describing colors by indicating the amount of cyan, magenta, yellow, and black needed to reproduce a particular color.

How is color specified in a document to be printed?

Software programs typically specify document color using RGB or CMYK color combinations. Additionally, they allow users to modify the color of each object in a document. For more information, see the software program Help topics.

How does the printer know what color to print?

When a user prints a document, information describing the type and color of each object is sent to the printer. The color information is passed through color conversion tables that translate the color into the appropriate amounts of cyan, magenta, yellow, and black toner needed to produce the desired color. The object information determines the application of color conversion tables. For example, it is possible to apply one type of color conversion table to text while applying a different color conversion table to photographic images.

Should I use PostScript or PCL emulation printer software? What settings should I use for the best color?

The PostScript driver is strongly recommended for best color quality. The default settings in the PostScript driver provide the preferred color quality for the majority of printouts.

Why doesn't the printed color match the color I see on the computer screen?

The color conversion tables used in Auto Color Correction mode generally approximate the colors of a standard computer monitor. However, because of technology differences that exist between printers and monitors, there are many colors that can also be affected by monitor variations and lighting conditions. For recommendations on how the printer color sample pages may be useful in solving certain color-matching problems, see the question, "How can I match a particular color (such as a corporate logo)?"

The printed page appears tinted. Can I adjust the color?

Sometimes a printed page may appear tinted (for example, everything printed seems to be too red). This can be caused by environmental conditions, paper type, lighting conditions, or user preference. In these instances, adjust the Color Balance setting to create a more preferable color. Color Balance provides the user with the ability to make subtle adjustments to the amount of toner being used in each color plane. Selecting positive or negative values for cyan, magenta, yellow, and black (from the Color Balance menu) will slightly increase or decrease the amount of toner used for the chosen color. For example, if a printed page has a red tint, then decreasing both magenta and yellow could potentially improve the color balance.

My color transparencies seem dark when they are projected. Is there anything I can do to improve the color?

This problem most commonly occurs when projecting transparencies with reflective overhead projectors. To obtain the highest projected color quality, transmissive overhead projectors are recommended. If a reflective projector must be used, then adjusting the Toner Darkness setting to 1, 2, or 3 will lighten the transparency. Make sure to print on the recommended type of color transparencies.

What is manual color correction?

When manual color correction is enabled, the printer employs user-selected color conversion tables to process objects. However, Color Correction must be set to Manual, or no user-defined color conversion will be implemented. Manual color correction settings are specific to the type of object being printed (text, graphics, or images), and how the color of the object is specified in the software program (RGB or CMYK combinations).

Notes:

- Manual color correction is not useful if the software program does not specify colors with RGB or CMYK combinations. It is also not effective in situations in which the software program or the computer operating system controls the adjustment of colors.
- The color conversion tables—applied to each object when Color Correction is set to Auto—generate preferred colors for the majority of documents.

To manually apply a different color conversion table:

- 1 From the Quality menu, select **Color Correction**, and then select **Manual**.
- 2 From the Quality menu, select **Manual Color**, and then select the appropriate color conversion table for the affected object type.

Manual Color menu

Object type	Color conversion tables
RGB Image RGB Text RGB Graphics	<ul style="list-style-type: none">• Vivid—Produces brighter, more saturated colors and may be applied to all incoming color formats.• sRGB Display—Produces an output that approximates the colors displayed on a computer monitor. Black toner usage is optimized for printing photographs.• Display—True Black—Produces an output that approximates the colors displayed on a computer monitor. Uses only black toner to create all levels of neutral gray.• sRGB Vivid—Provides an increased color saturation for the sRGB Display color correction. Black usage is optimized for printing business graphics.• Off—No color correction is implemented.

Object type	Color conversion tables
CMYK Image CMYK Text CMYK Graphics	<ul style="list-style-type: none"> • US CMYK—Applies color correction to approximate the SWOP (Specifications for Web Offset Publishing) color output. • Euro CMYK—Applies color correction to approximated EuroScale color output. • Vivid CMYK—Increases the color saturation of the US CMYK color correction setting. • Off—No color correction is implemented.

How can I match a particular color (such as a corporate logo)?

From the printer Quality menu, nine types of Color Samples sets are available. These are also available from the Color Samples page of the Embedded Web Server. Selecting any sample set generates a multiple-page printout consisting of hundreds of colored boxes. Either a CMYK or RGB combination is located on each box, depending on the table selected. The observed color of each box is obtained by passing the CMYK or RGB combination labeled on the box through the selected color conversion table.

By examining Color Samples sets, a user can identify the box whose color is the closest to the desired color. The color combination labeled on the box can then be used for modifying the color of the object in a software program. For more information, see the software program Help topics. Manual color correction may be necessary to utilize the selected color conversion table for the particular object.

Selecting which Color Samples set to use for a particular color-matching problem depends on the Color Correction setting being used (Auto, Off, or Manual), the type of object being printed (text, graphics, or images), and how the color of the object is specified in the software program (RGB or CMYK combinations). When the printer Color Correction setting is set to Off, the color is based on the print job information; and no color conversion is implemented.

Note: The Color Samples pages are not useful if the software program does not specify colors with RGB or CMYK combinations. Additionally, certain situations exist in which the software program or the computer operating system adjusts the RGB or CMYK combinations specified in the program through color management. The resulting printed color may not be an exact match of the Color Samples pages.

What are detailed Color Samples and how do I access them?

Detailed Color Samples sets are available only through the Embedded Web Server of a network printer. A detailed Color Samples set contains a range of shades (displayed as colored boxes) that are similar to a user-defined RGB or CMYK value. The likeness of the colors in the set are dependent on the value entered in the RGB or CMYK Increment box.

To access a detailed Color Samples set from the Embedded Web Server:

- 1 Open a Web browser.
- 2 In the address bar, type the network printer IP address.
- 3 Click **Configuration**.
- 4 Click **Color Samples**.
- 5 Click **Detailed Options** to narrow the set to one color range.
- 6 When the Detailed Options page appears, select a color conversion table.
- 7 Enter the RGB or CMYK color number.

8 Enter an Increment value from 1–255.

Note: The closer the value is to 1, the narrower the color sample range will appear.

9 Click **Print** to print the detailed Color Samples set.

Contacting Customer Support

When you call Customer Support, describe the problem you are experiencing, the message on the display, and the troubleshooting steps you have already taken to find a solution.

You need to know your printer model type and serial number. For more information, see the label on the inside top front cover of the printer. The serial number is also listed on the menu settings page.

In the U.S. or Canada, call (1-800-539-6275). For other countries/regions, visit the Lexmark Web site at www.lexmark.com.

Notices

Product information

Product name:

Lexmark C540

Model(s):

210

Product name:

Lexmark C543dn

230

Product name:

Lexmark C544n, dn, dtn

430

Product name:

Lexmark C544dw

43W

Machine type:

5025

Edition notice

June 2008

The following paragraph does not apply to any country where such provisions are inconsistent with local law: LEXMARK INTERNATIONAL, INC., PROVIDES THIS PUBLICATION "AS IS" WITHOUT WARRANTY OF ANY KIND, EITHER EXPRESS OR IMPLIED, INCLUDING, BUT NOT LIMITED TO, THE IMPLIED WARRANTIES OF MERCHANTABILITY OR FITNESS FOR A PARTICULAR PURPOSE. Some states do not allow disclaimer of express or implied warranties in certain transactions; therefore, this statement may not apply to you.

This publication could include technical inaccuracies or typographical errors. Changes are periodically made to the information herein; these changes will be incorporated in later editions. Improvements or changes in the products or the programs described may be made at any time.

References in this publication to products, programs, or services do not imply that the manufacturer intends to make these available in all countries in which it operates. Any reference to a product, program, or service is not intended to state or imply that only that product, program, or service may be used. Any functionally equivalent product, program, or service that does not infringe any existing intellectual property right may be used instead. Evaluation and verification of operation in conjunction with other products, programs, or services, except those expressly designated by the manufacturer, are the user's responsibility.

For Lexmark technical support, visit support.lexmark.com.

For information on supplies and downloads, visit www.lexmark.com.

If you don't have access to the Internet, you can contact Lexmark by mail:

Lexmark International, Inc.
Bldg 004-2/CSC
740 New Circle Road NW
Lexington, KY 40550

© 2008 Lexmark International, Inc.

All rights reserved.

UNITED STATES GOVERNMENT RIGHTS

This software and any accompanying documentation provided under this agreement are commercial computer software and documentation developed exclusively at private expense.

Trademarks

Lexmark, Lexmark with diamond design, and MarkNet are trademarks of Lexmark International, Inc., registered in the United States and/or other countries.

PrintCryption is a trademark of Lexmark International, Inc.

PCL® is a registered trademark of the Hewlett-Packard Company. PCL is Hewlett-Packard Company's designation of a set of printer commands (language) and functions included in its printer products. This printer is intended to be compatible with the PCL language. This means the printer recognizes PCL commands used in various application programs, and that the printer emulates the functions corresponding to the commands.

The following terms are trademarks or registered trademarks of these companies:

Albertus	The Monotype Corporation plc
Antique Olive	Monsieur Marcel OLIVE
Apple-Chancery	Apple Computer, Inc.
Arial	The Monotype Corporation plc
CG Times	Based on Times New Roman under license from The Monotype Corporation plc, is a product of Agfa Corporation
Chicago	Apple Computer, Inc.
Clarendon	Linotype-Hell AG and/or its subsidiaries
Eurostile	Nebiolo
Geneva	Apple Computer, Inc.
GillSans	The Monotype Corporation plc
Helvetica	Linotype-Hell AG and/or its subsidiaries
Hoefler	Jonathan Hoefler Type Foundry
ITC Avant Garde Gothic	International Typeface Corporation
ITC Bookman	International Typeface Corporation

ITC Mona Lisa	International Typeface Corporation
ITC Zapf Chancery	International Typeface Corporation
Joanna	The Monotype Corporation plc
Marigold	Arthur Baker
Monaco	Apple Computer, Inc.
New York	Apple Computer, Inc.
Oxford	Arthur Baker
Palatino	Linotype-Hell AG and/or its subsidiaries
Stempel Garamond	Linotype-Hell AG and/or its subsidiaries
Taffy	Agfa Corporation
Times New Roman	The Monotype Corporation plc
Univers	Linotype-Hell AG and/or its subsidiaries

All other trademarks are the property of their respective owners.

Federal Communications Commission (FCC) compliance information statement

This product has been tested and found to comply with the limits for a Class B digital device, pursuant to Part 15 of the FCC Rules. Operation is subject to the following two conditions: (1) this device may not cause harmful interference, and (2) this device must accept any interference received, including interference that may cause undesired operation

The FCC Class B limits are designed to provide reasonable protection against harmful interference when the equipment is operated in a residential installation. This equipment generates, uses, and can radiate radio frequency energy and, if not installed and used in accordance with the instructions, may cause harmful interference to radio communications. However, there is no guarantee that interference will not occur in a particular installation. If this equipment does cause harmful interference to radio or television reception, which can be determined by turning the equipment off and on, the user is encouraged to try to correct the interference by one or more of the following measures:

- Reorient or relocate the receiving antenna.
- Increase the separation between the equipment and receiver.
- Connect the equipment into an outlet on a circuit different from that to which the receiver is connected.
- Consult your point of purchase or service representative for additional suggestions.

The manufacturer is not responsible for radio or television interference caused by using other than recommended cables or by unauthorized changes or modifications to this equipment. Unauthorized changes or modifications could void the user's authority to operate this equipment.

Note: To assure compliance with FCC regulations on electromagnetic interference for a Class B computing device, use a properly shielded and grounded cable such as Lexmark part number 1021231 for parallel attach or 1021294 for USB attach. Use of a substitute cable not properly shielded and grounded may result in a violation of FCC regulations.

Any questions regarding this compliance information statement should be directed to:

Director of Lexmark Technology & Services
Lexmark International, Inc.
740 West New Circle Road
Lexington, KY 40550
(859) 232-3000

Exposure to radio frequency radiation

The following notice is applicable if your printer has a wireless network card installed.

The radiated output power of this device is far below the FCC radio frequency exposure limits. A minimum separation of 20 cm (8 inches) must be maintained between the antenna and any persons for this device to satisfy the RF exposure requirements of the FCC.

Industry Canada notices

Industry Canada compliance statement

This Class B digital apparatus meets all requirements of the Canadian Interference-Causing Equipment Standard ICES-003.

Avis de conformité aux normes de l'industrie du Canada

Cet appareil numérique de classe B est conforme aux exigences de la norme canadienne relative aux équipements pouvant causer des interférences NMB-003.

Industry Canada radio interference statement

Industry Canada (Canada)

This device complies with Industry Canada specification RSS-210. Operation is subject to the following two conditions: (1) this device may not cause interference, and (2) this device must accept any interference, including interference that may cause undesired operation of the device.

This device has been designed to operate only with the antenna provided. Use of any other antenna is strictly prohibited per regulations of Industry Canada.

To prevent radio interference to the licensed service, this device is intended to be operated indoors and away from windows to provide maximum shielding. Equipment (or its transmit antenna) that is installed outdoors is subject to licensing.

The installer of this radio equipment must ensure that the antenna is located or pointed such that it does not emit RF fields in excess of Health Canada limits for the general population; consult Safety Code 6, obtainable from Health Canada's Web site www.hc-sc.gc.ca/rpb.

The term "IC:" before the certification/registration number only signifies that the Industry Canada technical specifications were met.

Industry Canada (Canada)

Cet appareil est conforme à la norme RSS-210 d'Industry Canada. Son fonctionnement est soumis aux deux conditions suivantes :

(1) cet appareil ne doit pas provoquer d'interférences et (2) il doit accepter toute interférence reçue, y compris celles risquant d'altérer son fonctionnement.

Cet appareil a été conçu pour fonctionner uniquement avec l'antenne fournie. L'utilisation de toute autre antenne est strictement interdite par la réglementation d'Industry Canada.

En application des réglementations d'Industry Canada, l'utilisation d'une antenne de gain supérieur est strictement interdite.

Pour empêcher toute interférence radio au service faisant l'objet d'une licence, cet appareil doit être utilisé à l'intérieur et loin des fenêtres afin de garantir une protection optimale.

Si le matériel (ou son antenne d'émission) est installé à l'extérieur, il doit faire l'objet d'une licence.

L'installateur de cet équipement radio doit veiller à ce que l'antenne soit implantée et dirigée de manière à n'émettre aucun champ HF dépassant les limites fixées pour l'ensemble de la population par Santé Canada. Reportez-vous au Code de sécurité 6 que vous pouvez consulter sur le site Web de Santé Canada www.hc-sc.gc.ca/rpb.

Le terme « IC » précédant le numéro de d'accréditation/inscription signifie simplement que le produit est conforme aux spécifications techniques d'Industry Canada.

European Community (EC) directives conformity

This product is in conformity with the protection requirements of EC Council directives 2004/108/EC, 2006/95/EC, and 1999/5/EC on the approximation and harmonization of the laws of the Member States relating to electromagnetic compatibility, safety of electrical equipment designed for use within certain voltage limits and on radio equipment and telecommunications terminal equipment.

Compliance is indicated by the CE marking.



A declaration of conformity with the requirements of the directives is available from the Director of Manufacturing and Technical Support, Lexmark International, S. A., Boigny, France.

This product satisfies the limits of EN 55022; safety requirements of EN 60950; radio spectrum requirements of ETSI EN 300 328; and the EMC requirements of EN 55024, ETSI EN 301 489-1 and ETSI EN 301 489-17.

Česky	Společnost Lexmark International, Inc. tímto prohlašuje, že výrobek tento výrobek je ve shodě se základními požadavky a dalšími příslušnými ustanoveními směrnice 1999/5/ES.
Dansk	Lexmark International, Inc. erklærer herved, at dette produkt overholder de væsentlige krav og øvrige relevante krav i direktiv 1999/5/EF.
Deutsch	Hiermit erklärt Lexmark International, Inc., dass sich das Gerät dieses Gerät in Übereinstimmung mit den grundlegenden Anforderungen und den übrigen einschlägigen Bestimmungen der Richtlinie 1999/5/EG befindet.

Ελληνική	ΜΕ ΤΗΝ ΠΑΡΟΥΣΑ Η LEXMARK INTERNATIONAL, INC. ΔΗΛΩΝΕΙ ΟΤΙ ΑΥΤΟ ΤΟ ΠΡΟΪΟΝ ΣΥΜΜΟΡΦΩΝΕΤΑΙ ΠΡΟΣ ΤΙΣ ΟΥΣΙΩΔΕΙΣ ΑΠΑΙΤΗΣΕΙΣ ΚΑΙ ΤΙΣ ΛΟΙΠΕΣ ΣΧΕΤΙΚΕΣ ΔΙΑΤΑΞΕΙΣ ΤΗΣ ΟΔΗΓΙΑΣ 1999/5/ΕΚ.
English	Hereby, Lexmark International, Inc., declares that this type of equipment is in compliance with the essential requirements and other relevant provisions of Directive 1999/5/EC.
Español	Por medio de la presente, Lexmark International, Inc. declara que este producto cumple con los requisitos esenciales y cualesquiera otras disposiciones aplicables o exigibles de la Directiva 1999/5/CE.
Eesti	Käesolevaga kinnitab Lexmark International, Inc., et seade see toode vastab direktiivi 1999/5/EÜ põhinõuetele ja nimetatud direktiivist tulenevatele muudele asjakohastele sätetele.
Suomi	Lexmark International, Inc. vakuuttaa täten, että tämä tuote on direktiivin 1999/5/EY oleellisten vaatimusten ja muiden sitä koskevien direktiivin ehtojen mukainen.
Français	Par la présente, Lexmark International, Inc. déclare que l'appareil ce produit est conforme aux exigences fondamentales et autres dispositions pertinentes de la directive 1999/5/CE.
Magyar	Alulírott, Lexmark International, Inc. nyilatkozom, hogy a termék megfelel a vonatkozó alapvető követelményeknek és az 1999/5/EC irányelv egyéb előírásainak.
Íslenska	Hér með lýsir Lexmark International, Inc. yfir því að þessi vara er í samræmi við grunnkröfur og aðrar kröfur, sem gerðar eru í tilskipun 1999/5/EC.
Italiano	Con la presente Lexmark International, Inc. dichiara che questo prodotto è conforme ai requisiti essenziali ed alle altre disposizioni pertinenti stabilite dalla direttiva 1999/5/CE.
Latviski	Ar šo Lexmark International, Inc. deklarē, ka šis izstrādājums atbilst Direktīvas 1999/5/EK būtiskajām prasībām un citiem ar to saistītajiem noteikumiem.
Lietuvių	Šiuo Lexmark International, Inc. deklaruoja, kad šis produktas atitinka esminius reikalavimus ir kitas 1999/5/EB direktyvos nuostatas.
Malti	Bil-preżenti, Lexmark International, Inc., jiddikjara li dan il-prodott huwa konformi mal-ħtiġijiet essenzjali u ma dispożizzjonijiet oħrajn relevanti li jinsabu fid-Direttiva 1999/5/KE.
Nederlands	Hierbij verklaart Lexmark International, Inc. dat het toestel dit product in overeenstemming is met de essentiële eisen en de andere relevante bepalingen van richtlijn 1999/5/EG.
Norsk	Lexmark International, Inc. erklærer herved at dette produktet er i samsvar med de grunnleggende krav og øvrige relevante krav i direktiv 1999/5/EF.
Polski	Niniejszym Lexmark International, Inc. oświadcza, że niniejszy produkt jest zgodny z zasadniczymi wymogami oraz pozostałymi stosownymi postanowieniami Dyrektywy 1999/5/EC.
Português	A Lexmark International Inc. declara que este este produto está conforme com os requisitos essenciais e outras disposições da Diretiva 1999/5/CE.
Slovensky	Lexmark International, Inc. týmto vyhlasuje, že tento produkt spĺňa základné požiadavky a všetky príslušné ustanovenia smernice 1999/5/ES.
Slovensko	Lexmark International, Inc. izjavlja, da je ta izdelek v skladu z bistvenimi zahtevami in ostalimi relevantnimi določili direktive 1999/5/ES.
Svenska	Härmed intygar Lexmark International, Inc. att denna produkt står i överensstämmelse med de väsentliga egenskapskrav och övriga relevanta bestämmelser som framgår av direktiv 1999/5/EG.

India emissions notice

This device uses very low power low range RF communication that has been tested and found not to cause any interference whatsoever. The manufacturer is not responsible in case of any disputes arising out of requirement of permissions from any local authority, regulatory bodies or any organization, required by the end-user to install and operate this product at his premises.

भारतीय उत्सर्जन सूचना

यह यंत्र बहुत ही कम शक्ति, कम रेंज के RF कम्युनिकेशन का प्रयोग करता है जिसका परीक्षण किया जा चुका है, और यह पाया गया है कि यह किसी भी प्रकार का व्यवधान उत्पन्न नहीं करता। इसके अंतिम प्रयोक्ता द्वारा इस उत्पाद को अपने प्रांगण में स्थापित एवं संचालित करने हेतु किसी स्थानीय प्राधिकरण, नियामक निकायों या किसी संगठन से अनुज्ञा प्राप्त करने की जरूरत के संबंध में उठे विवाद की स्थिति में विनिर्माता जिम्मेदार नहीं है।

Static sensitivity notice

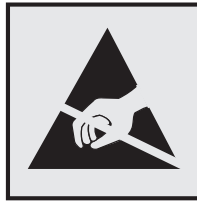

This symbol identifies static-sensitive parts. Do not touch in the areas near these symbols without first touching the metal frame of the printer.

Noise emission levels

The following measurements were made in accordance with ISO 7779 and reported in conformance with ISO 9296.

Note: Some modes may not apply to your product.

1-meter average sound pressure, dBA	
Printing	48 dBA
Ready	Inaudible

Values are subject to change. See www.lexmark.com for current values.

Temperature information

Ambient temperature	15.6-32.2°C (60-90°F)
Shipping and storage temperature	-40-433°C (-40-110°F)

Waste from Electrical and Electronic Equipment (WEEE) directive



The WEEE logo signifies specific recycling programs and procedures for electronic products in countries of the European Union. We encourage the recycling of our products. If you have further questions about recycling options, visit the Lexmark Web site at www.lexmark.com for your local sales office phone number.

Product disposal

Do not dispose of the printer or supplies in the same manner as normal household waste. Consult your local authorities for disposal and recycling options.

ENERGY STAR

Applicable only to models with a duplex unit installed.



Laser notice

The printer is certified in the U.S. to conform to the requirements of DHHS 21 CFR Subchapter J for Class I (1) laser products, and elsewhere is certified as a Class I laser product conforming to the requirements of IEC 60825-1.

Class I laser products are not considered to be hazardous. The printer contains internally a Class IIIb (3b) laser that is a maximum 15 milliwatt gallium arsenide laser operating in the wavelength of 770-795 nanometers. The laser system and printer are designed so there is never any human access to laser radiation above a Class I level during normal operation, user maintenance, or prescribed service condition.

Laser advisory label

A laser notice label may be affixed to this printer as shown:



Power consumption

Product power consumption

The following table documents the power consumption characteristics of the product.

Note: Some modes may not apply to your product.

Mode	Description	Power consumption (Watts)
Printing	The product is generating hard-copy output from electronic inputs.	480 W (C540, C543); 500 W (C544)
Copying	The product is generating hard-copy output from hard-copy original documents.	N/A
Scanning	The product is scanning hard-copy documents.	N/A
Ready	The product is waiting for a print job.	34 W (C540, C543); 36 W (C544)
Power Saver	The product is in energy-saving mode.	<18 W (C540); <16 W (C543, C544)
Off	The product is plugged into a wall outlet, but the power switch is turned off.	0 W

The power consumption levels listed in the previous table represent time-averaged measurements. Instantaneous power draws may be substantially higher than the average.

Values are subject to change. See www.lexmark.com for current values.

Power Saver

This product is designed with an energy-saving mode called Power Saver. The Power Saver Mode is equivalent to the EPA Sleep Mode. The Power Saver Mode saves energy by lowering power consumption during extended periods of inactivity. The Power Saver Mode is automatically engaged after this product is not used for a specified period of time, called the Power Saver Timeout.

Factory default Power Saver Timeout for this product (in minutes):	30 minutes
--	------------

By using the configuration menus, the Power Saver Timeout can be modified between 1 minute and 240 minutes. Setting the Power Saver Timeout to a low value reduces energy consumption, but may increase the response time of the product. Setting the Power Saver Timeout to a high value maintains a fast response, but uses more energy.

Off mode

If this product has an off mode which still consumes a small amount of power, then to completely stop product power consumption, disconnect the power supply cord from the wall outlet.

Total energy usage

It is sometimes helpful to calculate the total product energy usage. Since power consumption claims are provided in power units of Watts, the power consumption should be multiplied by the time the product spends in each mode in order to calculate energy usage. The total product energy usage is the sum of each mode's energy usage.

Statement of Limited Warranty

Lexmark C540

Lexmark C543dn

Lexmark C544n, dn, dtn

Lexmark C544dw

Lexmark International, Inc., Lexington, KY

This limited warranty applies to the United States and Canada. For customers outside the U.S., refer to the country-specific warranty information that came with your product.

This limited warranty applies to this product only if it was originally purchased for your use, and not for resale, from Lexmark or a Lexmark Remarketer, referred to in this statement as "Remarketer."

Limited warranty

Lexmark warrants that this product:

—Is manufactured from new parts, or new and serviceable used parts, which perform like new parts

—Is, during normal use, free from defects in material and workmanship

If this product does not function as warranted during the warranty period, contact a Remarketer or Lexmark for repair or replacement (at Lexmark's option).

If this product is a feature or option, this statement applies only when that feature or option is used with the product for which it was intended. To obtain warranty service, you may be required to present the feature or option with the product.

If you transfer this product to another user, warranty service under the terms of this statement is available to that user for the remainder of the warranty period. You should transfer proof of original purchase and this statement to that user.

Limited warranty service

The warranty period starts on the date of original purchase as shown on the purchase receipt and ends 12 months later provided that the warranty period for any supplies and for any maintenance items included with the printer shall end earlier if it, or its original contents, are substantially used up, depleted, or consumed.

To obtain warranty service you may be required to present proof of original purchase. You may be required to deliver your product to the Remarketer or Lexmark, or ship it prepaid and suitably packaged to a Lexmark designated location. You are responsible for loss of, or damage to, a product in transit to the Remarketer or the Lexmark designated location.

When warranty service involves the exchange of a product or part, the item replaced becomes the property of the Remarketer or Lexmark. The replacement may be a new or repaired item.

The replacement item assumes the remaining warranty period of the original product.

Replacement is not available to you if the product you present for exchange is defaced, altered, in need of a repair not included in warranty service, damaged beyond repair, or if the product is not free of all legal obligations, restrictions, liens, and encumbrances.

Before you present this product for warranty service, remove all print cartridges, programs, data, and removable storage media (unless directed otherwise by Lexmark).

For further explanation of your warranty alternatives and the nearest Lexmark authorized servicer in your area contact Lexmark on the World Wide Web at <http://support.lexmark.com>.

Remote technical support is provided for this product throughout its warranty period. For products no longer covered by a Lexmark warranty, technical support may not be available or only be available for a fee.

Extent of limited warranty

Lexmark does not warrant uninterrupted or error-free operation of any product or the durability or longevity of prints produced by any product.

Warranty service does not include repair of failures caused by:

- Modification or unauthorized attachments
- Accidents, misuse, abuse or use inconsistent with Lexmark user's guides, manuals, instructions or guidance
- Unsuitable physical or operating environment
- Maintenance by anyone other than Lexmark or a Lexmark authorized servicer
- Operation of a product beyond the limit of its duty cycle
- Use of printing media outside of Lexmark specifications
- Refurbishment, repair, refilling or remanufacture by a third party of products, supplies or parts
- Products, supplies, parts, materials (such as toners and inks), software, or interfaces not furnished by Lexmark

TO THE EXTENT PERMITTED BY APPLICABLE LAW, NEITHER LEXMARK NOR ITS THIRD PARTY SUPPLIERS OR REMARKETERS MAKE ANY OTHER WARRANTY OR CONDITION OF ANY KIND, WHETHER EXPRESS OR IMPLIED, WITH RESPECT TO THIS PRODUCT, AND SPECIFICALLY DISCLAIM THE IMPLIED WARRANTIES OR CONDITIONS OF MERCHANTABILITY, FITNESS FOR A PARTICULAR PURPOSE, AND SATISFACTORY QUALITY. ANY WARRANTIES THAT MAY NOT BE DISCLAIMED UNDER APPLICABLE LAW ARE LIMITED IN DURATION TO THE WARRANTY PERIOD. NO WARRANTIES, EXPRESS OR IMPLIED, WILL APPLY AFTER THIS PERIOD. ALL INFORMATION, SPECIFICATIONS, PRICES, AND SERVICES ARE SUBJECT TO CHANGE AT ANY TIME WITHOUT NOTICE.

Limitation of liability

Your sole remedy under this limited warranty is set forth in this document. For any claim concerning performance or nonperformance of Lexmark or a Remarketer for this product under this limited warranty, you may recover actual damages up to the limit set forth in the following paragraph.

Lexmark's liability for actual damages from any cause whatsoever will be limited to the amount you paid for the product that caused the damages. This limitation of liability will not apply to claims by you for bodily injury or damage to real property or tangible personal property for which Lexmark is legally liable. **IN NO EVENT WILL LEXMARK BE LIABLE FOR ANY LOST PROFITS, LOST SAVINGS, INCIDENTAL DAMAGE, OR OTHER ECONOMIC OR CONSEQUENTIAL DAMAGES.** This is true even if you advise Lexmark or a Remarketer of the possibility of such damages. Lexmark is not liable for any claim by you based on a third party claim.

This limitation of remedies also applies to claims against any Suppliers and Remarketers of Lexmark. Lexmark's and its Suppliers' and Remarketers' limitations of remedies are not cumulative. Such Suppliers and Remarketers are intended beneficiaries of this limitation.

Additional rights

Some states do not allow limitations on how long an implied warranty lasts, or do not allow the exclusion or limitation of incidental or consequential damages, so the limitations or exclusions contained above may not apply to you.

This limited warranty gives you specific legal rights. You may also have other rights that vary from state to state.

DEVICE PATENT LICENSE

Lexmark reserves the right to discontinue selling these toner cartridges any time after it discontinues service support for this printer.

IMPORTANT: PLEASE READ BEFORE OPENING: Opening this package, installing the printing device software, or using the products inside confirms your acceptance of the following licenses/agreements:

License: The patented printer inside is licensed for, and designed to work with only genuine Lexmark toner cartridges and developer components for the life of the patented printer. You agree to: (1) use only genuine Lexmark toner cartridges and developer components with this printer except as otherwise provided below, and (2) pass this license/agreement to any subsequent user of this printer. The patented Lexmark toner cartridges and developer components inside are licensed subject to a restriction that they may be used only once. Following their initial use, you agree to return them only to Lexmark for recycling. Lexmark toner cartridges are designed to stop working after delivering a fixed amount of toner. A variable amount of toner may remain in them when replacement is required.

If you do not accept these terms, return the unopened package to your point of purchase. Replacement toner cartridge(s) sold without these terms are available through www.lexmark.com, may be refilled by you, or a third party, as the only cartridge alternative to be used with the licensed printer.

LEXMARK SOFTWARE LIMITED WARRANTY AND LICENSE AGREEMENTS

PLEASE READ CAREFULLY BEFORE USING THIS PRODUCT: BY USING THIS PRODUCT, YOU AGREE TO BE BOUND BY ALL THE TERMS AND CONDITIONS OF THIS SOFTWARE LIMITED WARRANTY AND LICENSE AGREEMENTS. IF YOU DO NOT AGREE WITH THE TERMS OF THIS SOFTWARE LIMITED WARRANTY AND LICENSE AGREEMENTS, PROMPTLY RETURN THE PRODUCT UNUSED AND REQUEST A REFUND OF THE AMOUNT YOU PAID. IF YOU ARE INSTALLING THIS PRODUCT FOR USE BY OTHER PARTIES, YOU AGREE TO INFORM THE USERS THAT USE OF THE PRODUCT INDICATES ACCEPTANCE OF THESE TERMS.

DEVICE LICENSE AGREEMENT

The patented printer is licensed for, and designed to work with only genuine Lexmark toner cartridges and developer components for the life of the patented printer. Under this patent license, you agree to: (1) use only genuine Lexmark toner cartridges and developer components with this printer except as otherwise provided below, and (2) pass this license/agreement to any subsequent user of this printer. The patented Lexmark toner cartridges and developer components inside are licensed subject to a restriction that they may be used only once. Following their initial use, you agree to return them only to Lexmark for recycling. Lexmark toner cartridges are designed to stop working after a delivering a fixed amount of toner. A variable amount of toner may remain in them when replacement is required. Replacement toner cartridge(s) sold without these terms are available through www.lexmark.com, may be refilled by you, or a third party, as the only cartridge alternative to be used with the licensed printer.

LEXMARK SOFTWARE LICENSE AGREEMENT

This Software License Agreement ("Software License Agreement") is a legal agreement between you (either an individual or a single entity) and Lexmark International, Inc. ("Lexmark") that, to the extent your Lexmark product or Software Program is not otherwise subject to a written software license agreement between you and Lexmark or its suppliers, governs your use of any Software Program installed on or provided by Lexmark for use in connection with your Lexmark product. The term "Software Program" includes machine-readable instructions, audio/visual content (such as images and recordings), and associated media, printed materials and electronic documentation, whether incorporated into, distributed with or for use with your Lexmark product.

- 1 STATEMENT OF SOFTWARE LIMITED WARRANTY.** Lexmark warrants that the media (e.g., diskette or compact disk) on which the Software Program (if any) is furnished is free from defects in materials and workmanship under normal use during the warranty period. The warranty period is ninety (90) days and commences on the date the Software Program is delivered to the original end-user. This limited warranty applies only to Software Program media purchased new from Lexmark or an Authorized Lexmark Reseller or Distributor. Lexmark will replace the Software Program should it be determined that the media does not conform to this limited warranty.
- 2 DISCLAIMER AND LIMITATION OF WARRANTIES.** EXCEPT AS PROVIDED IN THIS SOFTWARE LICENSE AGREEMENT AND TO THE MAXIMUM EXTENT PERMITTED BY APPLICABLE LAW, LEXMARK AND ITS SUPPLIERS PROVIDE THE SOFTWARE PROGRAM "AS IS" AND HEREBY DISCLAIM ALL OTHER WARRANTIES AND CONDITIONS, EITHER EXPRESS OR IMPLIED, INCLUDING, BUT NOT LIMITED TO, TITLE, NON-INFRINGEMENT, MERCHANTABILITY AND FITNESS FOR A PARTICULAR PURPOSE, AND ABSENCE OF VIRUSES, ALL WITH REGARD TO THE SOFTWARE PROGRAM. TO THE EXTENT LEXMARK CANNOT BY LAW DISCLAIM ANY COMPONENT OF THE IMPLIED WARRANTIES OF MERCHANTABILITY OR FITNESS FOR A PARTICULAR PURPOSE, LEXMARK LIMITS THE DURATION OF SUCH WARRANTIES TO THE 90-DAY TERM OF THE EXPRESS SOFTWARE LIMITED WARRANTY.

This Agreement is to be read in conjunction with certain statutory provisions, as that may be in force from time to time, that imply warranties or conditions or impose obligations on Lexmark that cannot be excluded or modified. If any such provisions apply, then to the extent Lexmark is able, Lexmark hereby limits its liability for breach of those provisions to one of the following: providing you a replacement copy of the Software Program or reimbursement of the price paid for the Software Program.

The Software Program may include internet links to other software applications and/or internet web pages hosted and operated by third parties unaffiliated with Lexmark. You acknowledge and agree that Lexmark is not responsible in any way for the hosting, performance, operation, maintenance, or content of, such software applications and/or internet web pages.

- 3 LIMITATION OF REMEDY.** TO THE MAXIMUM EXTENT PERMITTED BY APPLICABLE LAW, ANY AND ALL LIABILITY OF LEXMARK UNDER THIS SOFTWARE LICENSE AGREEMENT IS EXPRESSLY LIMITED TO THE GREATER OF THE PRICE PAID FOR THE SOFTWARE PROGRAM AND FIVE U.S. DOLLARS (OR THE EQUIVALENT IN LOCAL CURRENCY). YOUR SOLE REMEDY AGAINST LEXMARK IN ANY DISPUTE UNDER THIS SOFTWARE LICENSE AGREEMENT SHALL BE TO SEEK TO RECOVER ONE OF THESE AMOUNTS, UPON PAYMENT OF WHICH LEXMARK SHALL BE RELEASED AND DISCHARGED OF ALL FURTHER OBLIGATIONS AND LIABILITY TO YOU.

IN NO EVENT WILL LEXMARK, ITS SUPPLIERS, SUBSIDIARIES, OR RESELLERS BE LIABLE FOR ANY SPECIAL, INCIDENTAL, INDIRECT, EXEMPLARY, PUNITIVE, OR CONSEQUENTIAL DAMAGES (INCLUDING BUT NOT LIMITED TO LOST PROFITS OR REVENUES, LOST SAVINGS, INTERRUPTION OF USE OR ANY LOSS OF, INACCURACY IN, OR DAMAGE TO, DATA OR RECORDS, FOR CLAIMS OF THIRD PARTIES, OR DAMAGE TO REAL OR TANGIBLE PROPERTY, FOR LOSS OF PRIVACY ARISING OUT OR IN ANY WAY RELATED TO THE USE OF OR INABILITY TO USE THE SOFTWARE PROGRAM, OR OTHERWISE IN CONNECTION WITH ANY PROVISION OF THIS SOFTWARE LICENCE AGREEMENT), REGARDLESS OF THE NATURE OF THE CLAIM, INCLUDING BUT NOT LIMITED TO BREACH OF WARRANTY OR CONTRACT, TORT (INCLUDING NEGLIGENCE OR STRICT LIABILITY), AND EVEN IF LEXMARK, OR ITS SUPPLIERS, AFFILIATES, OR REMARKETERS HAVE BEEN ADVISED OF THE POSSIBILITY OF SUCH DAMAGES, OR FOR ANY CLAIM BY YOU BASED ON A THIRD-PARTY CLAIM, EXCEPT TO THE EXTENT THIS EXCLUSION OF DAMAGES IS DETERMINED LEGALLY INVALID. THE FOREGOING LIMITATIONS APPLY EVEN IF THE ABOVE-STATED REMEDIES FAIL OF THEIR ESSENTIAL PURPOSE.

- 4 U.S.A. STATE LAWS.** This Software Limited Warranty gives you specific legal rights. You may also have other rights that vary from state to state. Some states do not allow limitations on how long an implied warranty lasts or the exclusion of limitation of incidental or consequential damages, so the above limitations may not apply to you.
- 5 LICENSE GRANT.** Lexmark grants you the following rights provided you comply with all terms and conditions of this Software License Agreement:
- a Use.** You may Use one (1) copy of the Software Program. The term “Use” means storing, loading, installing, executing, or displaying the Software Program. If Lexmark has licensed the Software Program to you for concurrent use, you must limit the number of authorized users to the number specified in your agreement with Lexmark. You may not separate the components of the Software Program for use on more than one computer. You agree that you will not Use the Software Program, in whole or in part, in any manner that has the effect of overriding, modifying, eliminating, obscuring, altering or de-emphasizing the visual appearance of any trademark, trade name, trade dress or intellectual property notice that appears on any computer display screens normally generated by, or as a result of, the Software Program.
 - b Copying.** You may make one (1) copy of the Software Program solely for purposes of backup, archiving, or installation, provided the copy contains all of the original Software Program’s proprietary notices. You may not copy the Software Program to any public or distributed network.
 - c Reservation of Rights.** The Software Program, including all fonts, is copyrighted and owned by Lexmark International, Inc. and/or its suppliers. Lexmark reserves all rights not expressly granted to you in this Software License Agreement.
 - d Freeware.** Notwithstanding the terms and conditions of this Software License Agreement, all or any portion of the Software Program that constitutes software provided under public license by third parties (“Freeware”) is licensed to you subject to the terms and conditions of the software license agreement accompanying such Freeware, whether in the form of a discrete agreement, shrink-wrap license, or electronic license terms at the time of download or installation. Use of the Freeware by you shall be governed entirely by the terms and conditions of such license.
- 6 TRANSFER.** You may transfer the Software Program to another end-user. Any transfer must include all software components, media, printed materials, and this Software License Agreement and you may not retain copies of the Software Program or components thereof. The transfer may not be an indirect transfer, such as a consignment. Prior to the transfer, the end-user receiving the transferred Software Program must agree to all these Software License Agreement terms. Upon transfer of the Software Program, your license is automatically terminated. You may not rent, sublicense, or assign the Software Program except to the extent provided in this Software License Agreement.
- 7 UPGRADES.** To Use a Software Program identified as an upgrade, you must first be licensed to the original Software Program identified by Lexmark as eligible for the upgrade. After upgrading, you may no longer use the original Software Program that formed the basis for your upgrade eligibility.
- 8 LIMITATION ON REVERSE ENGINEERING.** You may not alter, decrypt, reverse engineer, reverse assemble, reverse compile or otherwise translate the Software Program or assist or otherwise facilitate others to do so, except as and to the extent expressly permitted to do so by applicable law for the purposes of inter-operability, error correction, and security testing. If you have such statutory rights, you will notify Lexmark in writing of any intended reverse engineering, reverse assembly, or reverse compilation. You may not decrypt the Software Program unless necessary for the legitimate Use of the Software Program.
- 9 ADDITIONAL SOFTWARE.** This Software License Agreement applies to updates or supplements to the original Software Program provided by Lexmark unless Lexmark provides other terms along with the update or supplement.

- 10 TERM.** This Software License Agreement is effective unless terminated or rejected. You may reject or terminate this license at any time by destroying all copies of the Software Program, together with all modifications, documentation, and merged portions in any form, or as otherwise described herein. Lexmark may terminate your license upon notice if you fail to comply with any of the terms of this Software License Agreement. Upon such termination, you agree to destroy all copies of the Software Program together with all modifications, documentation, and merged portions in any form.
- 11 TAXES.** You agree that you are responsible for payment of any taxes including, without limitation, any goods and services and personal property taxes, resulting from this Software License Agreement or your Use of the Software Program.
- 12 LIMITATION ON ACTIONS.** No action, regardless of form, arising out of this Software License Agreement may be brought by either party more than two years after the cause of action has arisen, except as provided under applicable law.
- 13 APPLICABLE LAW.** This Software License Agreement is governed by the laws of the Commonwealth of Kentucky, United States of America. No choice of law rules in any jurisdiction shall apply. The UN Convention on Contracts for the International Sale of Goods shall not apply.
- 14 UNITED STATES GOVERNMENT RESTRICTED RIGHTS.** The Software Program has been developed entirely at private expense. Rights of the United States Government to use the Software Program are as set forth in this Software License Agreement and as restricted in DFARS 252.227-7014 and in similar FAR provisions (or any equivalent agency regulation or contract clause).
- 15 CONSENT TO USE OF DATA.** You agree that Lexmark, its affiliates, and agents may collect and use information you provide in relation to support services performed with respect to the Software Program and requested by you. Lexmark agrees not to use this information in a form that personally identifies you except to the extent necessary to provide such services.
- 16 EXPORT RESTRICTIONS.** You may not (a) acquire, ship, transfer, or reexport, directly or indirectly, the Software Program or any direct product therefrom, in violation of any applicable export laws or (b) permit the Software Program to be used for any purpose prohibited by such export laws, including, without limitation, nuclear, chemical, or biological weapons proliferation.
- 17 AGREEMENT TO CONTRACT ELECTRONICALLY.** You and Lexmark agree to form this Software License Agreement electronically. This means that when you click the "Agree" or "I accept" button on this page or use this product, you acknowledge your agreement to these Software License Agreement terms and conditions and that you are doing so with the intent to "sign" a contract with Lexmark.
- 18 CAPACITY AND AUTHORITY TO CONTRACT.** You represent that you are of the legal age of majority in the place you sign this Software License Agreement and, if applicable, you are duly authorized by your employer or principal to enter into this contract.
- 19 ENTIRE AGREEMENT.** This Software License Agreement (including any addendum or amendment to this Software License Agreement that is included with the Software Program) is the entire agreement between you and Lexmark relating to the Software Program. Except as otherwise provided for herein, these terms and conditions supersede all prior or contemporaneous oral or written communications, proposals, and representations with respect to the Software Program or any other subject matter covered by this Software License Agreement (except to the extent such extraneous terms do not conflict with the terms of this Software License Agreement, any other written agreement signed by you and Lexmark relating to your Use of the Software Program). To the extent any Lexmark policies or programs for support services conflict with the terms of this Software License Agreement, the terms of this Software License Agreement shall control.

MICROSOFT CORPORATION NOTICES

- 1** This product may incorporate intellectual property owned by Microsoft Corporation. The terms and conditions upon which Microsoft is licensing such intellectual property may be found at **<http://go.microsoft.com/fwlink/?LinkId=52369>**.
- 2** This product is based on Microsoft Print Schema technology. You may find the terms and conditions upon which Microsoft is licensing such intellectual property at **<http://go.microsoft.com/fwlink/?LinkId=83288>**.

Index

Numerics

200 Paper jam <area name> 108
201.yy Paper jam <area name> 109
202.yy Paper jam <area name> 109
230.yy Paper jam <area name> 109
235.yy Paper jam <area name> 109
24x.yy Paper jam <area name> 109
250.yy Paper jam <area name> 110
250-sheet tray (standard)
 loading 38
30.yy <color> cartridge
 missing 105
31.yy Defective Imaging Kit 105
34 Short paper 105
35 Insufficient memory to support
 Resource Save feature 106
37 Insufficient memory for Flash
 Memory Defragment
 operation 106
37 Insufficient memory to collate
 job 106
38 Memory Full 106
39 Complex page, some data may
 not have printed 106
40 <color> Invalid refill, change
 cartridge 106
50 PPDS Font Error 106
51 Defective flash detected 107
52 Not enough free space in flash
 memory for resources 107
53 Unformatted flash
 detected 107
54 Standard <x> software
 error 107
54 Standard network software
 error 107
56 Standard USB port disabled 107
58 Too many flash options
 installed 107
58 Too many trays attached 108
59 Incompatible tray <x> 108

650-sheet duo drawer
 installing 23
650-sheet duo drawer (optional)
 loading 40
82 Replace waste toner box 108
82.yy Waste toner box missing 108
82.yy Waste toner box nearly
 full 108
88.yy <color> Cartridge is low 108
88.yy Replace <color>
 Cartridge 108
940.01 110
940.02 110
941.01 110
941.02 110
942.01 110
942.02 110
943.01 110
943.02 110

A

Active NIC menu 82
Asset Report menu 82
attaching cables 24

B

Black Low 101
Busy 101

C

cables, attaching
 Ethernet 24
 USB 24
Calibrating 101
calling Customer Support 159
canceling a job
 from Macintosh 61
 from the printer control panel 60
 from Windows 61
card stock
 loading 41
 tips on using 58
Check Config ID 101
Check Model Name 101
Check Serial Num 101
checking an unresponsive
 printer 140

cleaning
 exterior of the printer 135
Close Door 101
configuration information
 wireless network 28
configurations
 printer 11
configuring
 multiple printers 139
configuring supply
 notifications 138
conserving supplies 111
contacting Customer Support 159
Custom Types menu 79
Cyan Low 101

D

Default Source menu 71
Defective <color> Cartridge 105
Defragmenting Flash 101
Device Statistics menu 81
directory list, printing 60
display troubleshooting
 display is blank 140
 display shows only
 diamonds 140
display, printer control panel 14
documents, printing
 from Macintosh computer 54
 from Windows 54

E

Embedded Web Server 138
 copying settings to other
 printers 139
 setting up e-mail alerts 138
emission
 notices 162, 163, 164, 166
envelopes
 loading 41, 44
 tips 57
Ethernet networking
 Macintosh 33
 Windows 33
Ethernet port 24
exterior of the printer
 cleaning 135

e-mail
notice of low supply level 138
notice of paper jam 138
notice of paper needed 138
notice that different paper is
needed 138

F

FAQ about color printing 156
FCC notices 162, 163
fiber optic
network setup 33
finding information
customer support 10
publications 10
Finishing menu 89
Flash drive menu 100
flash memory card
installing 21
troubleshooting 143
Flushing buffer 101
font sample list
printing 60
Formatting Flash 101

G

General Settings menu 86
guidelines
card stock 58
envelopes 57
labels, paper 57
letterhead 55
transparencies 56

H

Hex Trace 102

I

Image menu 98
Imaging Kit 102
imaging kits
ordering 113
replacing 117, 123
Insert Tray <x> 102
installation
wireless network 29, 30
installing
options in driver 27
printer software 26
installing printer software
adding options 27

Invalid Engine Code 102
Invalid Network Code 102

J

jams
avoiding 63
locating doors and trays 64
locations 64
numbers 64
jams, clearing
200 65
201 65
202 66
230 68
235 68
242 68
250 69

L

labels, paper
tips on using 57
letterhead
loading, manual feeder 55
loading, trays 55
tips on using 55
light, indicator 14
linking trays 36
Load <src> <custom string> 102
Load <src> <custom type
name> 102
Load single sheet feeder with
<custom string> 103
Load single sheet feeder with
<custom type name> 102
Load single sheet feeder with
<size> 103
Load single sheet feeder with
<type> <size> 103
loading
250-sheet tray (standard) 38
650-sheet duo drawer
(optional) 40
card stock 41
envelopes 41, 44
letterhead in manual feeder 55
letterhead in trays 55
manual feeder 44
multipurpose feeder 41
transparencies 41

M

Macintosh
wireless network installation 30
Magenta Low 101
manual feeder
loading 44
memory card
installing 19
troubleshooting 144
menu settings
loading on multiple printers 139
Menu Settings Page menu 81
menu settings pages, printing 25
menus
Active NIC 82
Asset Report 82
Custom Types 79
Default Source 71
Device Statistics 81
diagram of 70
Finishing 89
Flash drive 100
General Settings 86
Image 98
Menu Settings Page 81
Network 83
Network Setup Page 81
Paper Loading 78
Paper Size/Type 72
Paper Texture 75
PCL Emul 96
PDF 95
PictBridge 99
PostScript 95
Print Defects 82
Print Demo 82
Print Directory 82
Print Fonts 81
Profile List 81
Quality 91
Setup 89
Supplies 71
USB 84
Utilities 94
Wireless 84
moving the printer 136
multipurpose feeder
loading 41

N

Network menu 83

- network setup page 26
- Network Setup Page menu 81
- noise emission levels 166
- notices 161, 162, 163, 164, 166, 167, 168

O

- options
 - 650-sheet duo drawer 23
 - flash memory card 21
 - internal 15
 - memory card 19
 - memory cards 15
- ordering
 - imaging kits 113
 - toner cartridges 112
 - waste toner bottle 113
- Output Bin Full 103

P

- paper
 - capacities 52
 - characteristics 46
 - letterhead 47
 - preprinted forms 47
 - recycled 52
 - selecting 47
 - selecting weight 76
 - setting size 37
 - setting type 37
 - storing 48
 - unacceptable 47
 - Universal Paper Size 80
 - Universal size setting 37
- paper feed troubleshooting
 - message remains after jam is cleared 145
- paper jams
 - avoiding 63
- Paper Loading menu 78
- Paper Size/Type menu 72
- paper sizes
 - supported by the printer 48
- Paper Texture menu 75
- paper types
 - duplex support 50
 - supported by printer 50
 - where to load 50
- paper types and weights
 - supported by the printer 50
- PCL Emul menu 96

- PDF menu 95
- PictBridge menu 99
- PostScript menu 95
- Power Saver 103
 - adjusting 137
- Print Defects menu 82
- Print Demo menu 82
- Print Directory menu 82
- Print Fonts menu 81
- print job
 - canceling from Macintosh 61
 - canceling from the printer control panel 60
 - canceling from Windows 61
- print quality
 - replacing developer unit 130
 - replacing imaging kits 117, 123
 - replacing the waste toner bottle 114
- print quality test pages,
printing 60
- print quality troubleshooting
 - blank pages 146
 - characters have jagged edges 146
 - clipped images 147
 - color misregistration 155
 - dark lines 147
 - gray background 147
 - light colored line, white line, or incorrectly colored line 148
 - poor transparency quality 154
- print irregularities 149
- print is too dark 150
- print is too light 151
- print quality test pages 145
- repeating defects 152
- skewed print 153
- solid color pages 153
- toner fog or background shading 153
- toner rubs off 153
- toner specks 154
- uneven print density 155

- print troubleshooting
 - error reading USB drive 140
 - incorrect characters print 141
 - incorrect margins 148
 - jammed page does not reprint 145
 - job prints from wrong tray 141
 - job prints on wrong paper 141

- job takes longer than expected 141
- jobs do not print 140
- Large jobs do not collate 142
- paper curl 149
- paper frequently jams 144
- tray linking does not work 142
- unexpected page breaks occur 142

- printer
 - configurations 11
 - minimum clearances 12
 - models 11
 - moving 136
 - selecting a location 12
 - shipping 136
- printer control panel 14
- printer messages
 - 200 Paper jam <area name> 108
 - 201.yy Paper jam <area name> 109
 - 202.yy Paper jam <area name> 109
 - 230.yy Paper jam <area name> 109
 - 235.yy Paper jam <area name> 109
 - 24x.yy Paper jam <area name> 109
 - 250.yy Paper jam <area name> 110
 - 30.yy <color> cartridge missing 105
 - 31.yy Defective Imaging Kit 105
 - 34 Short paper 105
 - 35 Insufficient memory to support Resource Save feature 106
 - 37 Insufficient memory for Flash Memory Defragment operation 106
 - 37 Insufficient memory to collate job 106
 - 38 Memory Full 106
 - 39 Complex page, some data may not have printed 106
 - 40 <color> Invalid refill, change cartridge 106
 - 50 PPDS Font Error 106
 - 51 Defective flash detected 107
 - 52 Not enough free space in flash memory for resources 107

- 53 Unformatted flash detected 107
- 54 Standard <x> software error 107
- 54 Standard network software error 107
- 56 Standard USB port disabled 107
- 58 Too many flash options installed 107
- 58 Too many trays attached 108
- 59 Incompatible tray <x> 108
- 82 Replace waste toner bottle 114
- 82 Replace waste toner box 108
- 82.yy Waste toner box missing 108
- 82.yy Waste toner box nearly full 108
- 88 Replace <color> Cartridge 128
- 88.yy <color> Cartridge is low 108
- 88.yy Replace <color> Cartridge 108
- 940.01 110
- 940.02 110
- 941.01 110
- 941.02 110
- 942.01 110
- 942.02 110
- 943.01 110
- 943.02 110
- Black Low 101
- Busy 101
- Calibrating 101
- Check Config ID 101
- Check Model Name 101
- Check Serial Num 101
- Close door 101
- Cyan Low 101
- Defective <color> Cartridge 105
- Defragmenting Flash 101
- Flushing buffer 101
- Formatting Flash 101
- Hex Trace 102
- Imaging Kit 102, 117, 123
- Insert Tray <x> 102
- Invalid Engine Code 102
- Invalid Network Code 102
- Load <src> <custom string> 102
- Load <src> <custom type name> 102

- Load single sheet feeder with <custom string> 103
- Load single sheet feeder with <custom type name> 102
- Load single sheet feeder with <size> 103
- Load single sheet feeder with <type> <size> 103
- Magenta Low 101
- Output Bin Full 103
- Power Saver 103
- Programming Code 103
- Programming Flash 104
- Ready 104
- Reload printed pages in Tray <x> 104
- Remote Management Active 104
- Remove packaging material 104
- Remove paper from standard output bin 104
- Replace <color> cartridge 104
- Replace Unsupported <color> Cartridge 105
- Tray <x> Empty 104
- Tray <x> Low 104
- Tray <x> Missing 104
- Unplug and change mode 105
- Unsupported USB device, please remove 104
- Unsupported USB hub, please remove 105
- Waiting 105
- Waiting, too many events 105
- Waste Toner Box 105
- Yellow Low 101
- printer options troubleshooting
 - drawers 143
 - flash memory card 143
 - memory card 144
 - multipurpose feeder 144
 - option not working 143
- printer problems, solving
 - basic 140
- printing
 - directory list 60
 - font sample list 60
 - from Macintosh computer 54
 - from USB flash memory device 59
 - from Windows 54
- installing printer software 26
- menu settings pages 25

- network setup page 26
- print quality test pages 60
- Profile List menu 81
- Programming Code 103
- Programming Flash 104

Q

- Quality menu 91

R

- Ready 104
- recycled paper
 - using 52
- recycling
 - Lexmark products 136
 - WEEE statement 167
- Reload printed pages in Tray <x> 104
- Remote Management Active 104
- Remove packaging material 104
- Remove paper from standard output bin 104
- Replace <color> cartridge 104
- Replace Unsupported <color> Cartridge 105
- restoring factory default settings 137

S

- safety information 9
- setting
 - Active NIC 82
 - paper size 37
 - paper type 37
 - Universal Paper Size 37
- setting up the printer
 - on a wired network (Macintosh) 33
 - on a wired network (Windows) 33
- Setup menu 89
- shipping the printer 136
- standard tray
 - loading 38
- status of supplies, checking 111
- storing
 - paper 48
 - supplies 111
- supplies
 - conserving 111
 - status of 111

- storing 111
- Supplies menu 71
- supplies, ordering
 - imaging kits 113
 - toner cartridges 112
 - waste toner bottle 113
- supply notifications
 - configuring 138
- system board
 - accessing 16

T

- toner cartridges
 - ordering 112
 - replacing 128
- transparencies
 - loading 41
 - tips on using 56
- Tray <x> Empty 104
- Tray <x> Low 104
- Tray <x> Missing 104
- tray linking 36
- tray unlinking 36
- trays
 - linking 36
 - unlinking 36
- troubleshooting
 - checking an unresponsive printer 140
 - contacting Customer Support 159
 - FAQ about color printing 156
 - solving basic printer problems 140
- troubleshooting, display
 - display is blank 140
 - display shows only diamonds 140
- troubleshooting, paper feed
 - message remains after jam is cleared 145
- troubleshooting, print
 - error reading USB drive 140
 - incorrect characters print 141
 - incorrect margins 148
 - jammed page does not reprint 145
 - job prints from wrong tray 141
 - job prints on wrong paper 141
 - job takes longer than expected 141
 - jobs do not print 140

- Large jobs do not collate 142
- paper curl 149
- paper frequently jams 144
- tray linking does not work 142
- unexpected page breaks occur 142
- troubleshooting, print quality
 - blank pages 146
 - characters have jagged edges 146
 - clipped images 147
 - color misregistration 155
 - dark lines 147
 - gray background 147
 - light colored line, white line, or incorrectly colored line 148
 - poor transparency quality 154
 - print irregularities 149
 - print is too dark 150
 - print is too light 151
 - print quality test pages 145
 - repeating defects 152
 - skewed print 153
 - solid color pages 153
 - toner fog or background shading 153
 - toner rubs off 153
 - toner specks 154
 - uneven print density 155
- troubleshooting, printer options
 - drawers 143
 - flash memory card 143
 - memory card 144
 - multipurpose feeder 144
 - option not working 143

U

- Universal Paper Size 80
 - setting 37
- Universal Setup menu 80
- unlinking trays 36
- Unplug and change mode 105
- Unsupported USB device, please remove 104
- Unsupported USB hub, please remove 105
- USB flash memory device 59
- USB menu 84
- USB port 24
- Utilities menu 94

W

- Waiting 105
- Waiting, too many events 105
- waste toner bottle
 - ordering 113
 - replacing 114
- Waste Toner Box 105
- Windows
 - wireless network installation 29
- wired network setup
 - using Windows 33
- wired networking
 - using Macintosh 33
- Wireless menu 84
- wireless network
 - configuration information 28
 - installation, using Macintosh 30
 - installation, using Windows 29

Y

- Yellow Low 101