

HEAT REMOVAL/ENVIRONMENTAL CONTROL

# Drycoolers - 60 Hz

GENERAL DATA



---

## TABLE OF CONTENTS

<b>LIEBERT DRYCOOLERS</b> .....	<b>1</b>
<b>FEATURES AND BENEFITS OF LIEBERT DRYCOOLERS</b> .....	<b>2</b>
<b>SELECTION PROCEDURE</b> .....	<b>3</b>
<b>PERFORMANCE DATA</b> .....	<b>4</b>
<b>DIMENSIONAL DATA</b> .....	<b>6</b>
<b>ELECTRICAL DATA</b> .....	<b>8</b>
<b>GUIDE SPECIFICATIONS</b> .....	<b>10</b>
Standard Features for Direct Drive Propeller Fan Drycoolers .....	10
General .....	10
Coil .....	10
Casing .....	10
Fans .....	10
Fan Motors .....	10
Electrical Control .....	10
<b>COMPONENT ASSEMBLY/INSTALLATION</b> .....	<b>11</b>
<b>APPLICATION/INSTALLATION GUIDELINES</b> .....	<b>12</b>
Location Guidelines .....	12
Drycooler Installation .....	12
Electrical Requirements of the Drycooler .....	12
Glycol/Inhibitor Solution .....	12
Piping Considerations .....	12
<b>PUMP PACKAGES &amp; EXPANSION TANK - OPTIONS</b> .....	<b>13</b>
<b>SUPPLEMENTARY APPLICATION DATA</b> .....	<b>14</b>
<b>MAINTENANCE GUIDELINES</b> .....	<b>14</b>

---

## Figures

Figure 1	Drycooler model numbers . . . . .	1
Figure 2	Capacity correction factor . . . . .	5
Figure 3	Pressure drop correction factor . . . . .	5
Figure 4	Dimensional data—1-4 fan models . . . . .	6
Figure 5	Dimensional data—6 & 8 fan models . . . . .	6
Figure 6	Typical footprint and unit anchor plan . . . . .	6
Figure 7	General arrangement diagram . . . . .	11
Figure 8	Pump package . . . . .	13
Figure 9	Pump mounting . . . . .	13
Figure 10	Expansion tank . . . . .	13
Figure 11	Pump curve, 60 Hz . . . . .	13

## Tables

Table 1	Drycooler performance data . . . . .	2
Table 2	Determining actual BTUH and MBH . . . . .	3
Table 3	Altitude correction . . . . .	3
Table 4	Drycooler performance data . . . . .	4
Table 5	Drycooler physical data . . . . .	7
Table 6	Drycooler electrical data . . . . .	8
Table 7	Drycooler electrical data—Quietline models . . . . .	9
Table 8	Pump data . . . . .	13
Table 9	Room dew point temperatures . . . . .	14
Table 10	Glycol concentration at various ambients . . . . .	14
Table 11	Volume in standard tube . . . . .	14

# LIEBERT DRYCOOLERS

Liebert drycoolers are designed to be used in conjunction with water cooled refrigeration and air conditioning machines as well as a variety of commercial and industrial applications requiring the rejection of heat from machinery or processes via a cooling fluid. During periods of low ambient temperatures, drycoolers may assist or replace the capacity requirements of mechanical chillers for a “free cooling” effect.

Liebert offers a full range of control options as well as expansion tank and pump packages. For cooling fluids other than water or water/glycol mixtures, contact Liebert, Heat Transfer.



Figure 1 Drycooler model numbers

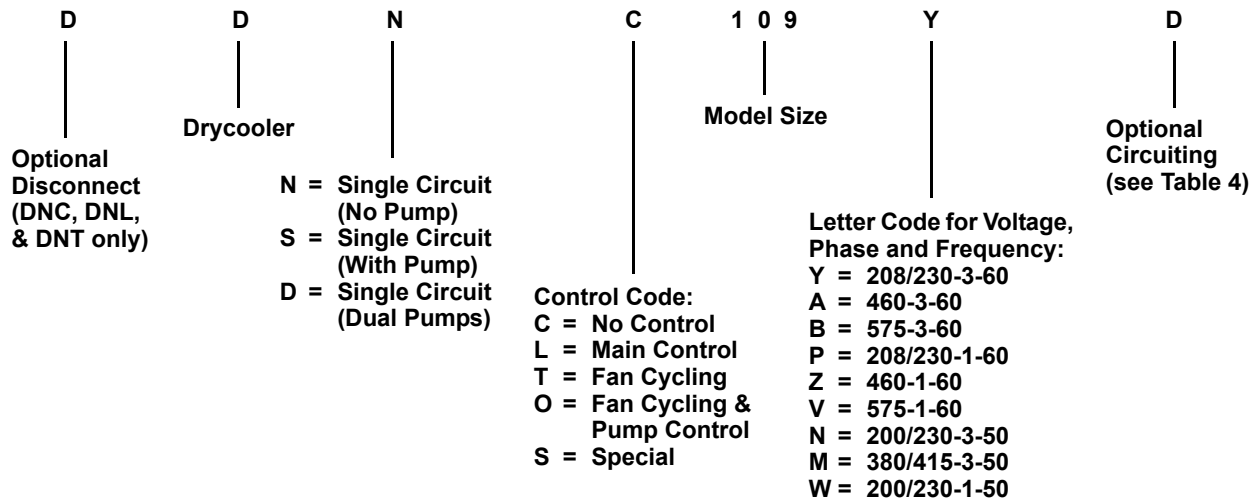

# FEATURES AND BENEFITS OF LIEBERT DRYCOOLERS

## Heat Rejection Module

The low-profile direct-drive propeller-fan type drycoolers utilize optimum circuitry to balance the heat rejection of the corresponding load. Constructed of aluminum with a copper-tube aluminum coil, the unit is quiet and corrosion resistant.

## Low Noise Level

All Liebert drycoolers are designed to operate at a minimal noise level. This is accomplished as the result of the Liebert fan blade design combined with a cabinet structure that minimizes air resistance. Quiet-Line models use low speed motors to achieve the quietest unit available.

## Easy Installation and Service

The heat rejection module is quickly and easily installed, because all internal wiring is completed at the factory with only electrical connections to be made at the job site.

## Maximum Reliability

Because these units are factory wired and tested, start-up problems are eliminated, and reliability of the overall system is greatly increased.

**Table 1 Drycooler performance data**

Model Number *D**	Standard Unit Data				Conn. + Size In/Out	# 26" Fans	Air Flow (CFM)	dBA**	Internal Volume (gal.)	Shipping Weight (lbs.)
	Total Heat Rej. @ 25 ITD	Flow Rate (gpm)	Press. Drop (Ft. Water)	# Internal Circuits						
<b>Standard Models</b>										
033	37950	10	9.1	4	3/4	1	7200	72.5	1.2	390
069	67040	20	8.9	8	1-1/4	1	6870	72.5	2.4	410
092	92380	30	8.6	12	1-1/2	1	6600	72.5	3.7	430
109	108760	40	8.1	16	2	1	6300	72.5	4.9	450
112	118200	40	10.1	16	2	1	6090	72.5	5.8	470
139	134100	40	7.1	16	2	2	13700	75.5	4.8	565
174	173400	40	10.5	16	2	2	13300	75.5	6.9	605
197	197000	40	13.9	16	2	2	12645	75.5	9.0	645
225	231000	65	10.9	26	2	2	12200	75.5	11.1	685
260	260200	60	10.1	24	2	3	19900	77.3	10.0	826
310	310500	80	9.8	32	2	3	19000	77.3	13.1	886
350	353000	80	14.6	32	2	3	17400	77.3	19.4	946
352	328400	60	12.9	24	2	4	24800	78.5	13.1	1070
419	393600	80	12.7	32	2	4	23650	78.5	17.4	1160
466	441200	100	12.7	40	2-1/2	4	22800	78.5	22.0	1250
491	469100	120	12.8	48	2-1/2	4	21700	78.5	26.3	1340
620	621000	160	9.8	64	2) 2-1/8	6	37900	80.3	27.0	1770
650	652100	130	15.2	52	2) 2-1/8	6	36500	80.3	33.1	1830
700	706100	160	14.6	64	2) 2-1/8	6	34800	80.3	39.3	1890
790	787200	160	12.7	64	2) 2-1/8	8	47300	81.5	35.0	2320
880	882000	200	12.7	80	4) 2-1/8	8	45500	81.5	44.4	2500
940	938200	240	12.5	96	4) 2-1/8	8	43400	81.5	52.6	2680
<b>Quiet-Line Models</b>										
040	44435	20	8.8	8	1-1/4	1	3110	56.5	2.4	410
057	57000	30	8.6	12	1-1/2	1	2990	56.5	3.7	430
060	62790	40	8.1	16	2	1	2840	56.5	4.9	450
080	88865	40	7.0	16	2	2	6220	59.5	4.8	565
111	110765	40	10.4	16	2	2	5980	59.5	6.9	605
121	120800	40	13.7	16	2	2	5680	59.5	9.0	645
158	166150	60	10.0	24	2	3	8970	61.3	10.0	825
173	184850	80	9.7	32	2	3	8520	61.3	13.1	885
178	186040	80	14.5	32	2	3	7440	61.3	19.4	950
205	218980	60	12.9	24	2	4	11680	62.5	13.1	1070
248	248420	80	12.5	32	2	4	11360	62.5	17.4	1160
347	369100	160	9.8	64	2) 2-1/8	6	17040	64.3	27.0	1940
356	371800	160	14.6	64	2) 2-1/8	6	14880	64.3	39.3	2060
453	496000	60	12.6	64	2) 2-1/8	8	22720	65.5	35.0	2550
498	505230	240	12.4	96	4) 2-1/8	8	19840	65.5	52.6	2910

Standard data based on 95°F EAT, 120°F EFT, 40% EG.

\*\* Sound Level - dBA @ 5 feet.

+ Connections 2" and smaller are FPT; 2-1/8" are ID. SWEAT

## SELECTION PROCEDURE

**Table 4** shows the performance specifications for Liebert drycoolers using a 40% by volume ethylene glycol solution at an average fluid temperature of 115°F with flow rates from 1.5 to 3 GPM/circuit and at standard air (.075 lbs/ft<sup>3</sup>). **Figure 2** and **Figure 3** offer correction factors to **Table 4** for average fluid temperatures and glycol percentages other than 115°F and 40%. **Table 3** correction factors may be used for performance at altitudes above sea level. For cooling applications other than shown, contact the Liebert Heat Transfer Division.

To select a drycooler from the tables in this bulletin, the following information must be known:

1. Fluid Flow Rate (GPM).
2. % Ethylene Glycol (% EG).
3. Design Air Temperature at the Drycooler (EAT).
4. Entering and Leaving Fluid Temperatures (EFT, LFT) or Total Heat Rejection (BTU/HR) and one of the Fluid Temperatures.
5. ITD (Initial Temperature Difference) = EFT - EAT

From the known data, calculate the following:

- Average Fluid Temperature (AFT) = (EFT + LFT)/2.
- Heat Rejection (BTUH) = Fluid Temp. Diff. x GPM x BTU/GPM Factor (**Table 2**).
- Leaving Fluid Temperature = 
$$EFT - \frac{BTUH}{(GPM) (BTU/GPM)}$$
- Other useful information:  
Leaving Air Temp. = 
$$\frac{EAT + \text{Drycooler BTUH}}{(1.08) (\text{Drycooler CFM})}$$

(Leaving Air Temperature should be lower than 145°F for proper motor operation.)

### Using Table 4 to select a drycooler

Calculate required MBH/ITD with corrections for glycol % and average fluid temperature.

1. Required MBH/ITD = 
$$\frac{BTUH}{(EFT - EAT) (1000) (\text{Fig. 1 Factor})}$$
2. Locate Model No. in **Table 4** having a GPM range within the required flow rate and an MBH equal to or greater than required. This gives an approximate size.
3. Divide the given GPM by the “No. of circuits” of the drycooler selected. The result is “GPM/CIR” and should be in the range of 1-1/2 to 3.
4. In **Table 4**, look up the model selected above and under “GPM/CIR” find the actual MBH. You may interpolate between columns.

The MBH found should be equal to or greater than the “required MBH /ITD.”

If the MBH is less than required, repeat from **Step 2** with a larger model. You may wish to repeat from **Step 2** with a smaller model for the most economical selection meeting the required MBH/ITD.

**Pressure Drop** - After selecting a model, look up the unit pressure drop following **Step 3** and **4** above. Multiply the pressure drop found by the **Figure 3** correction factor. If the product is higher than your system design, go back to **Step 2** and select a model with more circuits. This may be the same, or larger, unit.

### Example

Cool 40 GPM 20% ethylene glycol and water solution from 125(F) to 115(F). Design EAT = 95(F).

Calculate:

$$BTUH = (125 - 115) \times (40 \text{ GPM}) \times (480 \text{ BTU/GPM})$$

$$BTUH = 192,000$$

$$AFT = (125 + 115)/2 = 120(F)$$

$$\text{From Figure 2, corr. factor for 120 AFT and 20\% EG} = 1.04$$

1. Required MBH/ITD = 
$$\frac{192,000 \text{ BTUH}}{(125-95) (1000) (1.04)}$$
2. Locate model in **Table 4**. Models 092 through 139 fall into the GPM range but do not have the MBH capacity. Model 174 with 16 circuits is the smallest model meeting both the GPM range and MBH requirements.
3. GPM/CIR = 40 GPM/16 CIR = 2.5 GPM/CIR.
4. In **Table 4**, Model 174 with 16 circuits at the 2.5 GPM/CIR column provides 6.9 MBH/ITD, which exceeds the required MBH/ ITD of 6.15.

Pressure Drop = 10.5 ft. (from **Table 4**) x 0.93 (from **Figure 3**) = 9.8 ft. H<sub>2</sub>O.

**Table 2 Determining actual BTUH and MBH**

% Glycol Solution	0%	10%	20%	30%	40%	50%
BTUH/GPM	500	490	480	470	450	433

**Table 3 Altitude correction**

Alt. (Ft.)	0	1000	2000	5000	8000	12000	15000
Corr. Fact.	1	.979	.96	.9	.841	.762	.703

# PERFORMANCE DATA

**Table 4 Drycooler performance data**

Model Number	GPM Range	No. of Circuits	MBH/°F Initial Temperature Difference							
			1.5 GPM/CIR		2.0 GPM/CIR		2.5 GPM/CIR		3.0 GPM/CIR	
			MBH/ITD	PD ft. water	MBH/ITD	PD ft. water	MBH/ITD	PD ft. water	MBH/ITD	PD ft. water
<b>Standard Models</b>										
033	6-12	4*	1.3	4.2	1.5	6.2	1.6	9.2	1.7	12.8
069	6-12	4	1.8	7.3	2.1	11.4	2.3	17.0	2.4	23.6
	12-24	8*	2.3	3.9	2.5	6.0	2.7	8.9	2.8	12.4
092	9-18	6	2.7	7.0	3.0	11.7	3.3	16.7	3.5	23.0
	18-36	12 <sup>†</sup>	3.2	3.7	3.5	6.2	3.7	8.7	3.8	12.1
	24-48	16	3.4	3.0	3.6	4.6	3.8	6.3	3.9	8.7
109	12-24	8	3.3	7.1	3.7	11.3	3.9	16.8	4.1	23.3
	24-48	16*	3.9	3.8	4.1	6.0	4.3	8.2	4.5	11.4
112	24-48	16*	4.2	4.6	4.5	7.3	4.7	10.2	4.8	14.1
	39-78	26	4.5	2.6	4.7	4.4	4.9	6.6	5.0	9.2
139	12-24	8	3.6	6.2	4.1	9.8	4.6	14.6	4.9	20.2
	24-48	16*	4.5	3.3	5.0	5.2	5.4	7.1	5.6	9.8
174	24-48	16*	5.8	4.7	6.5	7.5	6.9	10.5	7.3	14.5
	36-72	24	6.4	3.2	7.0	4.9	7.4	7.3	7.6	10.1
197	24-48	16*	6.5	6.2	7.3	9.9	7.9	14.1	8.2	19.4
	48-96	32	7.7	3.0	8.3	5.0	8.7	7.0	8.9	9.8
225	24-48	16	7.1	7.4	8.0	12.0	8.6	17.2	9.0	23.9
	39-78	26*	8.1	4.4	8.8	7.4	9.2	11.0	9.5	15.2
260	24-48	16	7.5	6.4	8.7	10.2	9.5	14.7	10.1	20.3
	36-72	24*	9.7	4.4	9.7	6.8	10.4	10.4	10.9	14.0
310	24-48	16	8.3	8.4	9.7	13.5	10.7	19.5	11.4	26.9
	48-96	32*	10.7	4.1	11.7	6.9	12.4	9.8	12.9	13.6
350	24-48	16	9.2	12.2	10.9	20.9	12.1	29.1	12.9	40.2
	48-96	32*	12.3	6.0	13.4	10.1	14.1	14.6	14.6	20.2
	72-144	48	13.4	4.2	14.2	6.7	14.8	10.0	15.1	13.5
352	24-48	16	8.8	8.1	10.4	13.1	11.6	18.9	12.5	26.2
	36-72	24*	10.6	5.5	12.1	8.7	13.1	12.9	13.9	17.9
419	24-48	16	9.5	10.6	11.4	17.3	12.9	25.1	14.0	36.7
	48-96	32*	13.2	5.2	14.7	8.8	15.7	12.7	16.5	17.5
466	39-78	26	13.1	7.9	15.0	13.2	16.2	19.6	17.1	27.1
	60-120	40*	15.2	5.3	16.7	8.6	17.6	12.7	18.3	17.6
491	24-48	16	10.1	15.6	12.5	25.6				
	48-96	32	14.9	7.7	16.6	12.9	17.7	18.9	18.4	26.1
	72-144	48*	16.7	5.3	18.0	8.6	18.8	12.8	19.3	17.4
620	48-96	32	16.7	8.0	19.4	13.3	21.4	19.4	22.8	26.9
	96-192	64*	21.4	4.1	23.5	6.8	24.8	9.8	25.8	13.6
650	60-120	40	19.9	8.0	22.7	13.1	24.6	19.5	26.0	27.0
	78-156	52*	22.0	6.3	24.4	10.2	26.1	15.2	27.2	20.6
	120-240	80	24.6	4.1	26.5	6.7	27.8	9.9	28.7	13.4
700	48-96	32	18.5	11.8	21.8	19.8	24.1	29.0		
	96-192	64*	24.6	6.0	26.8	10.0	28.2	14.6	29.2	20.2
	144-288	96	26.7	4.0	28.5	6.7	29.5	9.8	30.2	13.5
790	48-96	32	18.9	10.2	22.8	17.1	25.7	25.0		
	96-192	64*	26.4	5.2	29.4	8.7	31.5	12.6	33.0	17.5
880	78-156	52	26.2	8.1	29.9	13.1	32.4	19.5	34.2	26.6
	120-240	80*	30.4	5.2	33.4	8.5	35.3	12.7	36.6	17.3
940	48-96	32	20.2	15.3	25.0	25.4				
	96-192	64	29.8	7.7	33.2	12.9	35.4	18.8	36.8	26.0
	144-288	96*	33.4	5.1	35.9	8.6	37.5	12.6	38.6	17.4



**Table 4 Drycooler performance data (continued)**

Model Number	GPM Range	No. of Circuits	MBH/°F Initial Temperature Difference							
			1.5 GPM/CIR		2.0 GPM/CIR		2.5 GPM/CIR		3.0 GPM/CIR	
			MBH/ITD	PD ft. water	MBH/ITD	PD ft. water	MBH/ITD	PD ft. water	MBH/ITD	PD ft. water
<b>Quiet-Line Models</b>										
040	6-12	4	1.4	7.4	1.5	11.4	1.6	17.0	1.7	23.5
	12-24	8*	1.6	3.9	1.7	5.9	1.8	8.9	1.8	12.3
057	18-36	12*	2.1	3.6	2.2	6.1	2.3	8.6	2.3	11.9
	24-48	16	2.2	3.0	2.3	4.6	2.3	6.2	2.4	8.6
060	12-24	8	2.2	7.1	2.3	11.3	2.4	16.6	2.5	23.0
	24-48	16*	2.4	3.8	2.5	5.9	2.5	8.1	2.5	11.3
080	12-24	8	2.7	6.2	3.0	9.8	3.2	14.5	3.3	20.1
	24-48	16*	3.2	3.3	3.4	5.1	3.6	7.0	3.7	9.7
111	24-48	16*	4.4	4.7	4.3	7.4	4.4	10.4	4.5	14.3
	36-72	24	4.2	3.2	4.4	4.8	4.6	7.2	4.6	10.0
121	24-48	16*	4.4	6.1	4.7	9.7	4.8	13.7	4.9	18.9
	48-96	32	4.8	2.9	4.9	4.9	5.0	7.0	5.1	9.6
158	24-48	16	5.6	6.4	6.0	10.3	6.3	14.7	6.6	20.3
	36-72	24*	6.0	4.3	6.4	6.7	6.6	10.0	6.8	13.8
173	24-48	16	6.1	8.4	6.6	13.5	6.9	19.5	7.1	26.9
	48-96	32*	6.9	4.1	7.2	6.8	7.4	9.7	7.5	13.5
178	24-48	16	6.5	12.3	6.9	20.0	7.1	29.1	7.3	40.1
	48-96	32*	7.1	6.0	7.3	10.0	7.4	14.5	7.5	20.0
	72-144	48	7.3	4.1	7.4	6.6	7.5	9.9	7.6	13.3
205	24-48	16	6.9	8.2	7.7	13.2	8.2	18.9	8.6	26.2
	36-72	24*	7.8	5.5	8.4	8.7	8.8	12.9	9.0	17.6
248	24-48	16	7.6	10.7	8.5	17.4	9.1	25.2	9.4	34.8
	48-96	32*	9.1	5.2	9.6	8.7	9.9	12.5	10.1	17.3
347	48-96	32	12.2	8.0	13.2	13.3	13.9	19.4	14.3	26.8
	96-192	64*	13.8	4.1	14.4	6.7	14.8	9.7	15.0	13.4
356	48-96	32	12.9	11.9	13.8	19.8	14.3	29.0	14.5	40.0
	96-192	64*	14.2	6.0	14.7	9.9	14.9	14.4	15.0	20.0
	144-288	96	14.6	4.0	14.9	6.6	15.0	9.6	15.2	13.3
453	48-96	32	15.2	10.3	17.0	17.2	18.1	25.1	18.9	34.7
	96-192	64*	18.2	5.2	19.2	8.7	19.9	12.5	20.3	17.3
498	48-96	32	16.1	15.4	17.8	25.6	18.8	37.6	19.2	51.8
	96-192	64	18.8	7.7	19.5	12.8	19.9	18.6	20.1	25.7
	144-288	96*	19.5	5.1	20.0	8.5	20.2	12.4	20.4	17.2

\* Standard Circuiting

Based on 40% Ethylene Glycol Solution at 115°F average solution temperature expressed in MBH.

Specifications subject to change without notice.

**Figure 2 Capacity correction factor**

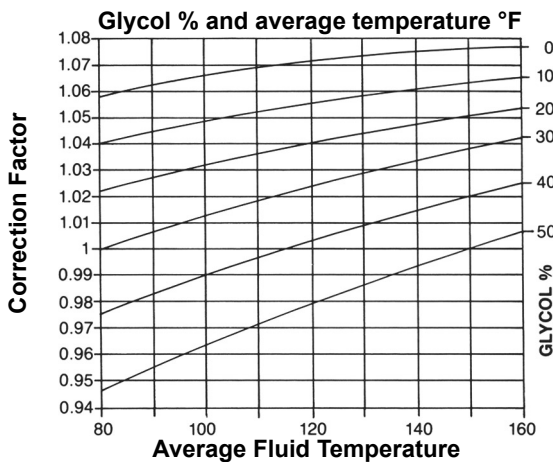

**Figure 3 Pressure drop correction factor**

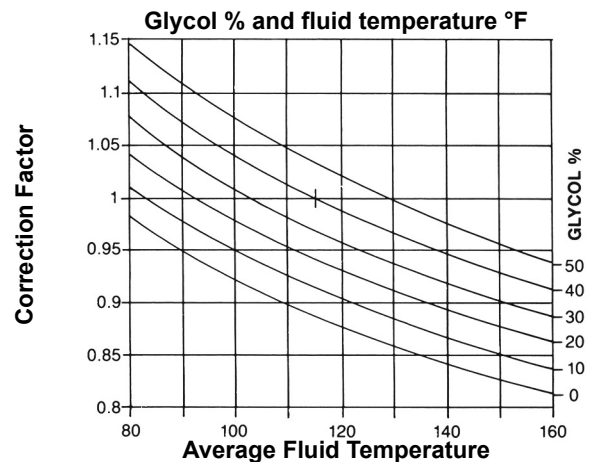

## DIMENSIONAL DATA

Figure 4 Dimensional data—1-4 fan models

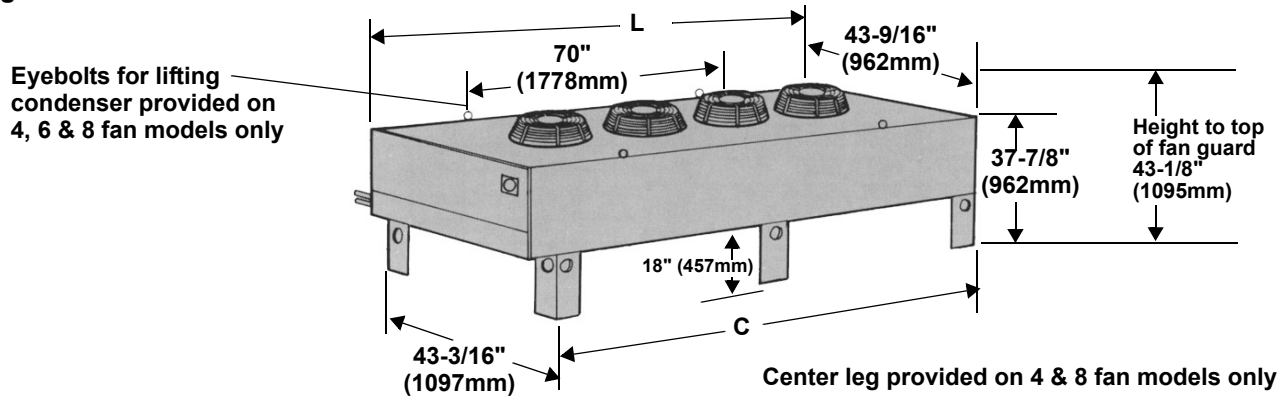

Figure 5 Dimensional data—6 & 8 fan models

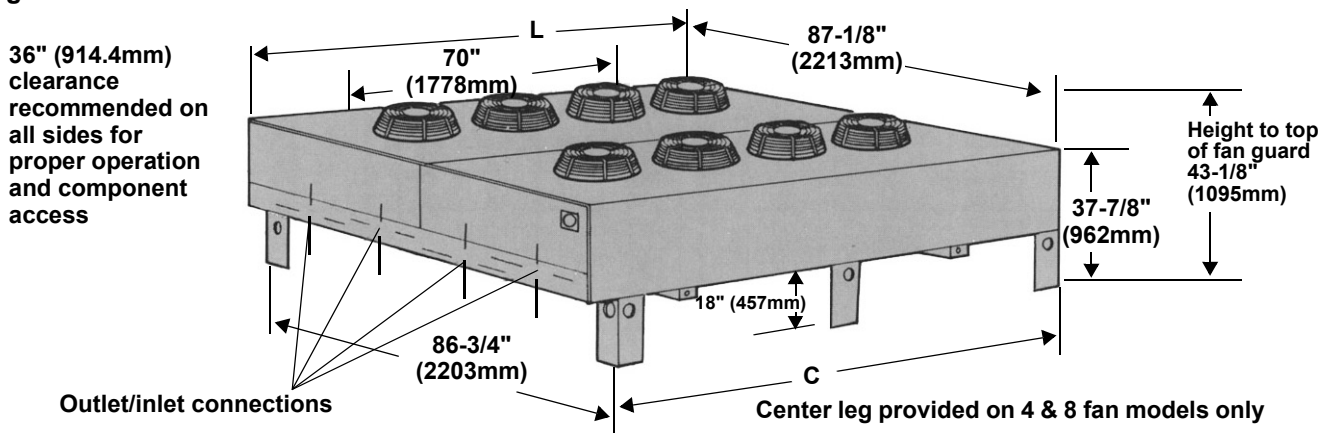
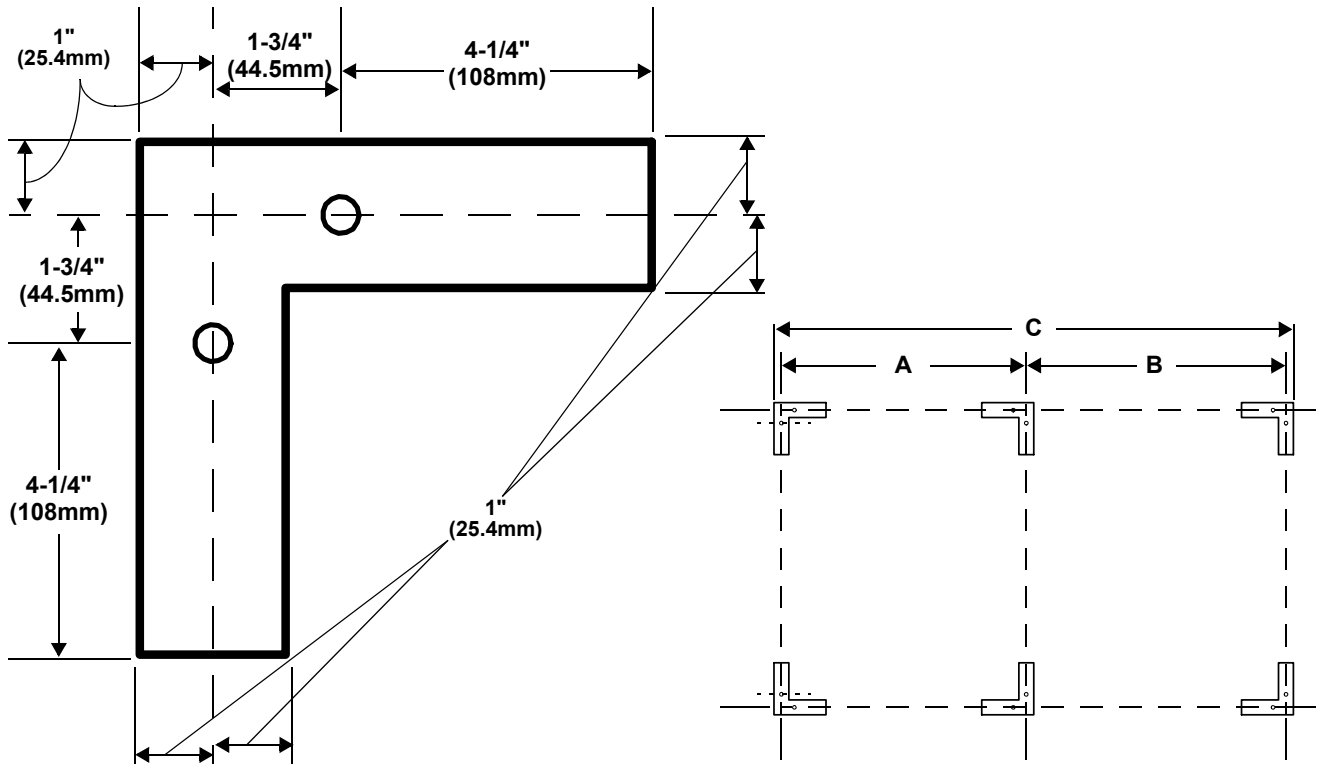

Figure 6 Typical footprint and unit anchor plan



**Table 5 Drycooler physical data**

Drycooler Model	Circuits	A	B	C	L	#Fans & Motors**	Conn FNPT In/Out
<b>Standard Models</b>							
-033	any	42	-	44	51.5	1	3/4
-069	any	42	-	44	51.5	1	1-1/4
-092	any	42	-	44	51.5	1	1-1/2
-109	any	42	-	44	51.5	1	2
-112	any	42	-	44	51.5	1	2
-139	any	82	-	84	91.5	2	2
-174	any	82	-	84	91.5	2	2
-197	any	82	-	84	91.5	2	2
-225	any	82	-	84	91.5	2	2
-260	any	122	-	124	131.5	3	2
-310	any	122	-	124	131.5	3	2
-350	any	122	-	124	131.5	3	2
-352	any	82	80	164	171.5	4	2
-419	any	82	80	164	171.5	4	2
-466	any	82	80	164	171.5	4	2-1/2
-491	any	82	80	164	171.5	4	2-1/2
-620	64 <sup>1</sup>	122	124	131.5	6	2) 2-1/8*	
-620	32	122	124	131.5	6	2) 2-1/8*	
-650	80	122	124	131.5	6	4) 2-1/8*	
-650	52 <sup>1</sup>	122	124	131.5	6	2) 2-1/8*	
-650	40	122	124	131.5	6	2) 2-1/8*	
-700	96	122	124	131.5	6	4) 2-1/8*	
-700	64 <sup>1</sup>	122	124	131.5	6	2) 2-1/8*	
-700	32	122	124	131.5	6	2) 2-1/8*	
-790	64 <sup>1</sup>	82	80	164	171.5	8	2) 2-1/8*
-790	32	82	80	164	171.5	8	2) 2-1/8*
-880	80 <sup>1</sup>	82	80	164	171.5	8	4) 2-1/8*
-880	52	82	80	164	171.5	8	2) 2-1/8*
-940	96 <sup>1</sup>	82	80	164	171.5	8	4) 2-1/8*
-940	64	82	80	164	171.5	8	2) 2-1/8*
-940	32	82	80	164	171.5	8	2) 2-1/8*
<b>Quiet-Line Models</b>							
-040	any	42	-	44	51.5	1	1-1/4
-057	any	42	-	44	51.5	1	1-1/2
-060	any	42	-	44	51.5	1	
-080	any	82	-	84	91.5	2	2
-111	any	82	-	84	91.5	2	2
-121	any	82	-	84	91.5	2	2
-158	any	122	-	124	131.5	3	2
-173	any	122	-	124	131.5	3	2
-178	any	122	-	124	131.5	3	2
-205	any	82	80	164	171.5	4	2
-248	any	82	80	164	171.5	4	2
-347	any	122	-	124	131.5	6	2) 2-1/8*
-356	64 <sup>1</sup>	122	-	124	131.5	6	2) 2-1/8*
-356	32	122	-	124	131.5	6	2) 2-1/8*
-453	64 <sup>1</sup>	82	80	164	171.5	8	2) 2-1/8*
-453	32	82	80	164	171.5	8	2) 2-1/8*
-498	96 <sup>1</sup>	82	80	164	171.5	8	4) 2-1/8*
-498	64	82	80	164	171.5	8	2) 2-1/8*
-498	32	82	80	164	171.5	8	2) 2-1/8*

\* Connections are ODS

\*\* Motors are 3/4 HP - standard models; 1/4 HP - Quiet-Line models

1. Standard circuiting

# ELECTRICAL DATA

**Table 6 Drycooler electrical data**

# of Fans	1				2				3				4				6				8							
Model #	33,69,92,109,112				139,174,197,225				260,310,350				352,419,466,491				620,650,700				790,880,940							
Pump Hp	ph	FLA	WSA	OPD	ph	FLA	WSA	OPD	ph	FLA	WSA	OPD	ph	FLA	WSA	OPD	ph	FLA	WSA	OPD	ph	FLA	WSA	OPD	ph	FLA	WSA	OPD
<b>208/230/60</b>																												
0.75	1	11.6	13.5	20.0	-	-	-	-	-	-	-	-	-	-	-	-	-	-	-	-	-	-	-	-	-	-	-	
0.75	3	7.0	7.9	15.0	3	10.5	11.4	15.0	3	14.0	14.9	15.0	3	17.5	18.4	20.0	3	24.5	25.4	25.0	3	31.5	32.4	35.0				
1.5	3	10.1	11.8	15.0	3	13.6	15.3	20.0	3	17.1	18.8	25.0	3	20.6	22.3	25.0	3	27.6	29.3	35.0	3	34.6	36.3	40.0				
2.0	3	11.0	12.9	20.0	3	14.5	16.4	20.0	3	18.0	19.9	25.0	3	21.5	23.4	30.0	3	28.5	30.4	35.0	3	35.5	37.4	40.0				
3.0	3	14.1	16.8	25.0	3	17.6	20.3	30.0	3	21.1	23.8	30.0	3	24.6	27.3	35.0	3	31.6	34.3	40.0	3	38.6	41.3	50.0				
5.0	3	20.2	24.4	40.0	3	23.7	27.9	40.0	3	27.2	31.4	45.0	3	30.7	34.9	50.0	3	37.7	41.9	50.0	3	44.7	48.9	60.0				
7.5	3	27.7	33.8	50.0	3	31.2	37.3	60.0	3	34.7	40.8	60.0	3	38.2	44.3	60.0	3	45.2	51.3	70.0	3	52.2	58.3	80.0				
10.0	3	34.3	42.0	70.0	3	37.8	45.5	70.0	3	41.3	49.0	70.0	3	44.8	52.5	80.0	3	51.8	59.5	90.0	3	58.8	66.5	90.0				
15	3	49.7	61.3	100.0	3	53.2	64.8	110.0	3	56.7	68.3	110.0	3	60.2	71.8	110.0	3	67.2	78.8	110.0	3	74.2	85.8	125.0				
<b>460/3/60</b>																												
0.75	3	3.3	3.7	15.0	3	5.0	5.4	15.0	3	6.7	7.1	15.0	3	8.4	8.8	15.0	3	11.8	12.2	15.0	3	15.2	15.6	15.0				
1.5	3	4.7	5.5	15.0	3	6.4	7.2	15.0	3	8.1	8.9	15.0	3	9.8	10.6	15.0	3	13.2	14.0	15.0	3	16.6	17.4	20.0				
2.0	3	5.1	6.0	15.0	3	6.8	7.7	15.0	3	8.5	9.4	15.0	3	10.2	11.1	15.0	3	13.6	14.5	15.0	3	17.0	17.9	20.0				
3.0	3	6.5	7.7	15.0	3	8.2	9.4	15.0	3	9.9	11.1	15.0	3	11.6	12.8	15.0	3	15.0	16.2	20.0	3	18.4	19.6	20.0				
5.0	3	9.3	11.2	15.0	3	11.0	12.9	20.0	3	12.7	14.6	20.0	3	14.4	16.3	20.0	3	17.8	19.7	25.0	3	21.2	23.1	30.0				
7.5	3	12.7	15.5	25.0	3	14.4	17.2	25.0	3	16.1	18.9	25.0	3	17.8	20.6	30.0	3	21.2	24.0	30.0	3	24.6	27.4	35.0				
10.0	3	15.7	19.2	30.0	3	17.4	20.9	30.0	3	19.1	22.6	35.0	3	20.8	24.3	35.0	3	24.2	27.7	40.0	3	27.6	31.1	45.0				
15	3	22.7	28.0	45.0	3	24.4	29.7	50.0	3	26.1	31.4	50.0	3	27.8	33.1	50.0	3	31.2	36.5	50.0	3	34.6	39.9	60.0				
<b>575/3/60</b>																												
0.75	3	2.7	3.1	15.0	3	4.1	4.5	15.0	3	5.5	5.9	15.0	3	6.9	7.3	15.0	3	9.7	10.1	15.0	3	12.5	12.9	15.0				
1.5	3	3.8	4.4	15.0	3	5.2	5.8	15.0	3	6.6	7.2	15.0	3	8.0	8.6	15.0	3	10.8	11.4	15.0	3	13.6	14.2	15.0				
2.0	3	4.1	4.8	15.0	3	5.5	6.2	15.0	3	6.9	7.6	15.0	3	8.3	9.0	15.0	3	11.1	11.8	15.0	3	13.9	14.6	15.0				
3.0	3	5.3	6.3	15.0	3	6.7	7.7	15.0	3	8.1	9.1	15.0	3	9.5	10.5	15.0	3	12.3	13.3	15.0	3	15.1	16.1	15.0				
5.0	3	7.5	9.0	15.0	3	8.9	10.4	15.0	3	10.3	11.8	15.0	3	11.7	13.2	15.0	3	14.5	16.0	20.0	3	17.3	18.8	20.0				
7.5	3	10.4	12.7	20.0	3	11.8	14.1	20.0	3	13.2	15.5	20.0	3	14.6	16.9	25.0	3	17.4	19.7	25.0	3	20.2	22.5	30.0				
10.0	3	12.4	15.2	25.0	3	13.8	16.6	25.0	3	15.2	18.0	25.0	3	16.6	19.4	30.0	3	19.4	22.2	30.0	3	22.2	25.0	35.0				
15	3	18.4	22.7	35.0	3	19.8	24.1	40.0	3	21.2	25.5	40.0	3	22.6	26.9	40.0	3	25.4	29.7	45.0	3	28.2	32.5	45.0				

**Table 7 Drycooler electrical data—Quietline models**

# of Fans	1				2				3				4				6				8							
Model #	40,57,60				80,111,121				158,173,178				205,248				347,356				453,498							
Pump Hp	ph	FLA	WSA	OPD	ph	FLA	WSA	OPD	ph	FLA	WSA	OPD	ph	FLA	WSA	OPD	ph	FLA	WSA	OPD	ph	FLA	WSA	OPD	ph	FLA	WSA	OPD
<b>208/230/60</b>																												
0.75	3	5.3	6.2	15.0	3	7.1	8.0	15.0	3	8.9	9.8	15.0	3	10.7	11.6	15.0	3	14.3	15.2	15.0	3	17.9	18.8	20.0				
1.5	3	8.4	10.1	15.0	3	10.2	11.9	15.0	3	12.0	13.7	20.0	3	13.8	15.5	20.0	3	17.4	19.1	25.0	3	21.0	22.7	25.0				
2.0	3	9.3	11.2	15.0	3	11.1	13.0	20.0	3	12.9	14.8	20.0	3	14.7	16.6	20.0	3	18.3	20.2	25.0	3	21.9	23.8	30.0				
3.0	3	12.4	15.1	25.0	3	14.2	16.9	25.0	3	16.0	18.7	25.0	3	17.8	20.5	30.0	3	21.4	24.1	30.0	3	25.0	27.7	35.0				
5.0	3	18.5	22.7	35.0	3	20.3	24.5	40.0	3	22.1	26.3	40.0	3	23.9	28.1	40.0	3	27.5	31.7	45.0	3	31.1	35.3	50.0				
7.5	3	26.0	32.1	50.0	3	27.8	33.9	50.0	3	29.6	35.7	50.0	3	31.4	37.5	60.0	3	35.0	41.1	60.0	3	38.6	44.7	60.0				
10.0	3	32.6	40.3	70.0	3	34.4	42.1	70.0	3	36.2	43.9	70.0	3	38.0	45.7	70.0	3	41.6	49.3	80.0	3	45.2	52.9	80.0				
15	3	48.0	59.6	100.0	3	49.8	61.4	100.0	3	51.6	63.2	100.0	3	53.4	65.0	110.0	3	57.0	68.6	110.0	3	60.6	72.2	110.0				
<b>460/3/60</b>																												
0.75	3	2.5	2.9	15.0	3	3.4	3.8	15.0	3	4.3	4.7	15.0	3	5.2	5.6	15.0	3	7.0	7.4	15.0	3	8.8	9.2	15.0				
1.5	3	3.9	4.7	15.0	3	4.8	5.6	15.0	3	5.7	6.5	15.0	3	6.6	7.4	15.0	3	8.4	9.2	15.0	3	10.2	11.0	15.0				
2.0	3	4.3	5.2	15.0	3	5.2	6.1	15.0	3	6.1	7.0	15.0	3	7.0	7.9	15.0	3	8.8	9.7	15.0	3	10.6	11.5	15.0				
3.0	3	5.7	6.9	15.0	3	6.6	7.8	15.0	3	7.5	8.7	15.0	3	8.4	9.6	15.0	3	10.2	11.4	15.0	3	12.0	13.2	15.0				
5.0	3	8.5	10.4	15.0	3	9.4	11.3	15.0	3	10.3	12.2	15.0	3	11.2	13.1	20.0	3	13.0	14.9	20.0	3	14.8	16.7	20.0				
7.5	3	11.9	14.7	25.0	3	12.8	15.6	25.0	3	13.7	16.5	25.0	3	14.6	17.4	25.0	3	16.4	19.2	30.0	3	18.2	21.0	30.0				
10.0	3	14.9	18.4	30.0	3	15.8	19.3	30.0	3	16.7	20.2	30.0	3	17.6	21.1	35.0	3	19.4	22.9	35.0	3	21.2	24.7	35.0				
15	3	21.9	27.2	45.0	3	22.8	28.1	45.0	3	23.7	29.0	45.0	3	24.6	29.9	50.0	3	26.4	31.7	50.0	3	28.2	33.5	50.0				
<b>575/3/60</b>																												
0.75	3	2.0	2.3	15.0	3	2.7	3.0	15.0	3	3.4	3.7	15.0	3	4.1	4.4	15.0	3	5.5	5.8	15.0	3	6.9	7.2	15.0				
1.5	3	3.1	3.7	15.0	3	3.8	4.4	15.0	3	4.5	5.1	15.0	3	5.2	5.8	15.0	3	6.6	7.2	15.0	3	8.0	8.6	15.0				
2.0	3	3.4	4.1	15.0	3	4.1	4.8	15.0	3	4.8	5.5	15.0	3	5.5	6.2	15.0	3	6.9	7.6	15.0	3	8.3	9.0	15.0				
3.0	3	4.6	5.6	15.0	3	5.3	6.3	15.0	3	6.0	7.0	15.0	3	6.7	7.7	15.0	3	8.1	9.1	15.0	3	9.5	10.5	15.0				
5.0	3	6.8	8.3	15.0	3	7.5	9.0	15.0	3	8.2	9.7	15.0	3	8.9	10.4	15.0	3	10.3	11.8	15.0	3	11.7	13.2	15.0				
7.5	3	9.7	12.0	20.0	3	10.4	12.7	20.0	3	11.1	13.4	20.0	3	11.8	14.1	20.0	3	13.2	15.5	20.0	3	14.6	16.9	25.0				
10.0	3	11.7	14.5	25.0	3	12.4	15.2	25.0	3	13.1	15.9	25.0	3	13.8	16.6	25.0	3	15.2	18.0	25.0	3	16.6	19.4	30.0				
15	3	17.7	22.0	35.0	3	18.4	22.7	35.0	3	19.1	23.4	40.0	3	19.8	24.1	40.0	3	21.2	25.5	40.0	3	22.6	26.9	40.0				

---

## GUIDE SPECIFICATIONS

---

### Standard Features for Direct Drive Propeller Fan Drycoolers

Furnish and install Liebert Model \_\_\_\_\_ Air-Cooled Drycoolers, arranged for vertical air flow. Drycoolers shall be draw-through design and shall perform in accordance with the schedule.

#### General

Each drycooler shall consist of casing, drycooler coil, propeller fans direct-driven by individual fan motors, fan guards, and mounting legs.

Fan motors shall be furnished for operation on a \_\_\_\_\_ V, \_\_\_\_\_PH, \_\_\_\_\_ Hz power supply.

#### Coil

The drycooler coil shall be constructed on copper tubes on a staggered tube pattern. Tubes shall be expanded into continuous, rippled aluminum fins. The fins shall have full-depth fin collars completely covering the copper tube. Copper tubes shall be connected to heavy wall type "L" headers, inlet coil connector tubes shall pass through relieved holes in the tube sheet, for maximum resistance to piping strain and vibration.

Coils shall be factory leak-tested at 300 PSIG (minimum) dehydrated, evacuated and sealed.

#### Casing

The drycooler casing shall be constructed of bright aluminum sheet. Casing shall be divided into individual fan sections by full width baffles. Structural support members, including coil support frame, motor and drive support shall be galvanized steel for strength and corrosion resistance. Aluminum legs with rigging holes shall be provided for hoisting the unit into position.

#### Fans

Fans shall have zinc plated steel or aluminum blades. Fan shall be secured to fan shaft by means of a heavy-duty keyed hub and dual set screws. Fan diameter shall be 30" or less. Fans shall be factory-balanced and run before shipment.

Fan guards shall be heavy gauge, close-meshed, steel wire, with corrosion resistant finish.

#### Fan Motors

Fan motors shall be equipped with rain slingers and permanently sealed ball bearings. Motors shall include built-in overload protection. Motors shall be rigidly mounted on die-formed galvanized steel supports.

#### Quiet-Line Motors

Fan motors shall be 12-pole, 570 rpm, equipped with rain shields and permanently sealed ball bearings. Motors shall include built-in overload protection. Motors shall be rigidly mounted on die-formed galvanized steel supports.

#### Electrical Control

All electrical connections (and electrical low ambient control options) shall be provided in weatherproof enclosure. The enclosure shall be integral with the drycooler for pleasing appearance as well as functional protection.

The base model (DNC) shall have the motor(s) factory wired to a three phase power block in the electrical enclosure. Main electrical control model (DNL) provides magnetic contactor and control voltage for remote starting of the drycooler.

The drycooler shall be provided with optional disconnect switch mounted and wired.

Fan cycling model (DNT) shall be used to control leaving fluid temperature by cycling fans in one or two steps. The 24 volt control circuit furnished, consists of control transformer, fan contactor(s) and temperature controls) as specified.

Fan cycling with pump control model (DSO)-single pump, (DDO)-dual pump shall have the features as the fan cycling model plus starter(s) for the pump(s) and a built-in disconnect switch.

# COMPONENT ASSEMBLY/INSTALLATION

## Leg Assembly

The legs are shipped loose and are to be field mounted as shown with the hardware provided.

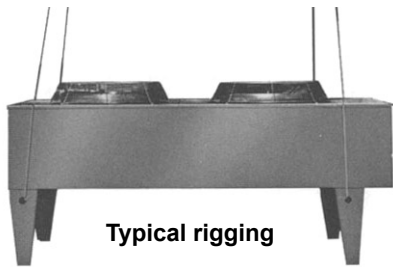
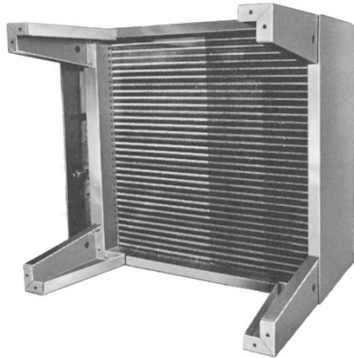

Typical rigging

## Rigging

Holes in the dry cooler legs permit lifting the unit. Spreader bars are required. Four, 6 and 8 fan models have additional lifting eyes.

## High Voltage Electrical Connections

Line Voltage is connected to the terminal strip or directly to the factory supplied locking disconnect (optional). Check voltage and compare to nameplate.



## Low Voltage Electrical Connections

A control interlock between the indoor and outdoor equipment must be minimum 16 ga. for up to 75 ft. or not to exceed 1 volt drop in control line.

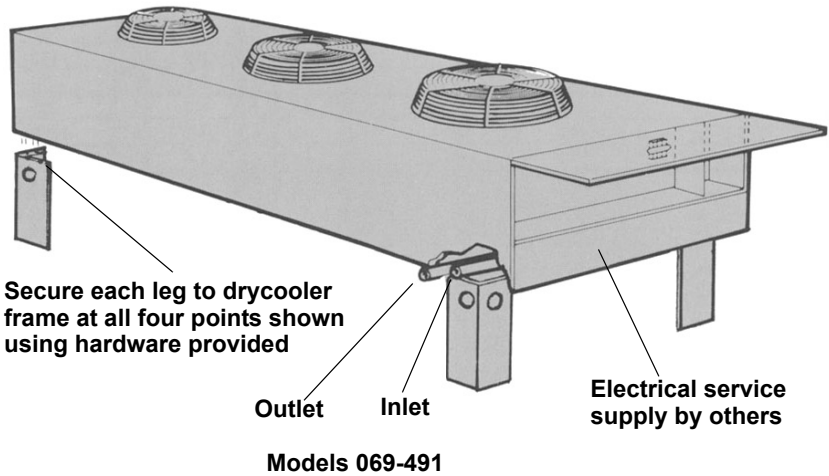
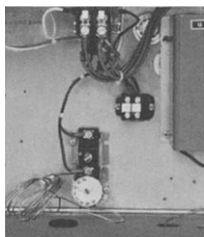

Models 620 through 940 have 2 sets of connections on end of unit

Figure 7 General arrangement diagram

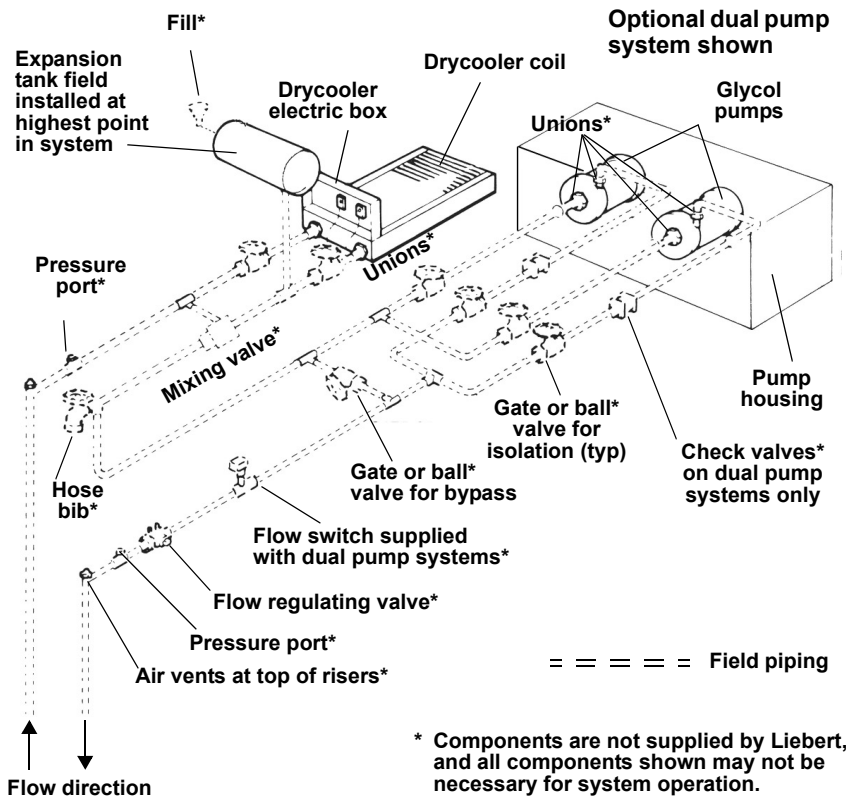

---

## APPLICATION/INSTALLATION GUIDELINES

---

### Location Guidelines

To ensure an adequate air supply, locate drycoolers in a **clean air area**, away from loose dirt and foreign matter that may clog the coil. In addition, drycoolers **must not** be placed near steam, hot air, or fume exhausts. Also, drycoolers should be **no closer** than 3 feet from a wall, obstruction or adjacent unit with no obstructions over the unit. Install drycoolers in a level position to assure proper vent and drain.

All drycooler legs have mounting holes for securing the unit to steel supports or concrete pads.

For roof installation, mount drycoolers on steel supports in accordance with local codes. To minimize sound and vibration transmission, mount steel supports across load-bearing walls.

For ground installations, a concrete pad will support the load.

### Drycooler Installation

The drycooler should be located for maximum security and maintenance accessibility. Avoid ground level sites with public access or areas which contribute to heavy snow or ice accumulations. Utilize centrifugal fan drycoolers when placing a drycooler in a building.

### Electrical Requirements of the Drycooler

Electrical service is required for all drycoolers at the location of the outdoor system. The power supply does not necessarily have to be the same voltage supply as required by the indoor unit. This separate power supply may be 208, 230, 460 or 575 volt, 60 Hz. For electrical characteristics of the standard voltage drycoolers, see Full Load Amps (FLA) of the drycooler in **Tables 6 and 7** and FLA of the pump, if used, in **Table 8**. Dual element, time delay type fuses or "HACR" circuit breakers at the main power source. The only electrical connection between the

indoor unit and the drycooler is a two wire control interlock which is field-connected when provided.

### Glycol/Inhibitor Solution

The percentage of glycol to water will be determined by the outdoor ambient in which the system is operating. Just as critical is the inhibitor used with the glycol.

Commercial ethylene glycol (Union Carbide Ucartherm, Dow Chemical Dowtherm SR-1, and Texaco E.G. Heat Transfer Fluid 100), when pure, is generally less corrosive to the metals than water. It will, however, assume the corrosivity of the water from which it is prepared and may become increasingly corrosive with use if not properly inhibited. Proper inhibitor maintenance must be performed to prevent corrosion of the glycol system. Consult glycol manufacturer for testing and maintenance of inhibitors.

**Automotive antifreeze is unacceptable and must not be used in any glycol fluid system.**

There are two basic concepts of corrosion inhibition: They are classified as corrosion inhibitors or environmental stabilizers. The corrosion inhibitors function by forming a surface barrier that protects the metals. Environmental stabilizers decrease corrosion by stabilizing or favorably altering the overall environment. An alkaline buffer, such as borax, is a simple example, since its prime purpose is to maintain an alkaline condition (ph above 7).

The quality of the water of dilution must be considered because water may contain corrosive elements which reduce the effectiveness of the inhibited formulation. Surface waters that are classified as soft and are low in chloride and sulfate ion content (less than 100 ppm each) should be employed.

### Piping Considerations

**CAUTION:** When using water under pressure to test the system for leaks, immediately charge the tested system with glycol. Complete system drain-down cannot be assured. Replacing broken, frozen piping is a needless exercise. A preferred test method utilizes common refrigerant gas pressurized with nitrogen. A refrigerant type leak detector will find even the smallest leak when properly used.

**Galvanized pipe or other components should not be used with an inhibited glycol system.**

**All fluid piping must comply with local codes.** Care in sizing pipes will help reduce pumping power and operating costs.

Manual shut-off valves and unions should be installed at the supply and return line of each major system component. This permits routine service or emergency isolation of the component.

Where connecting to a city water supply, provide a disconnection means. A city water source is desirable for initially charging the system and as an emergency standby cooling source.

The minimum glycol temperature to be supplied from the drycooler determines whether the supply and return lines should be insulated to prevent condensation (see **Table 9**).

Vents are required at system high points to vent trapped air when filling the system.

Since the system is not open to the atmosphere, an expansion tank must be provided for expansion and contraction of the fluid with temperature change. A relief valve is also necessary.

A fill port is necessary for charging the system with glycol.

Depending on the complexity of the system, various other devices may be specified, such as pressure gauges, valves, pumps and sensors.



# PUMP PACKAGES & EXPANSION TANK - OPTIONS

**Figure 8 Pump package**

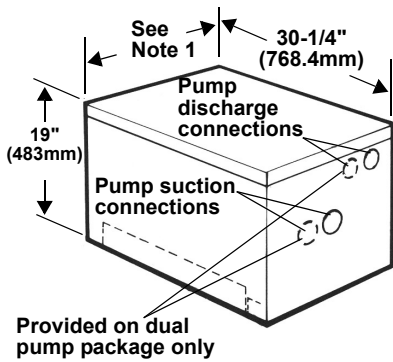

**Figure 9 Pump mounting**

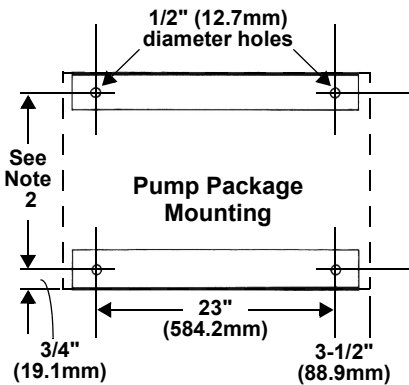

**Notes**

1. Single pump packages are 17-1/4" (438.2mm) wide. Dual pump packages are 32-1/4" (819.2mm) wide.
2. Mounting holes are 15-11/32" (389.7mm) apart on single pump packages and 30-11/32" (770.7mm) apart on dual pump packages.
3. 7-1/2hp dimensions not shown—consult factory.

**Figure 10 Expansion tank**

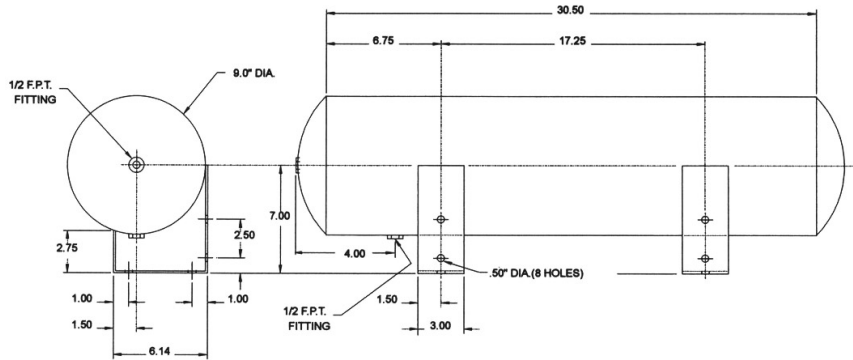

**Expansion Tank- (P/N 1C16717P1)**

This tank, included in a standard pump package, has an internal volume of 8.8 gal. (33 l) and a maximum pressure of 100 psi (690 kPa).

This tank is sized for a typical "open" system with a fluid volume of less than 75 gal. (280l). When used in a "closed" system, volumes of up to 140 gal. (910l) can be accommodated. The use of a safety relief valve, field supplied, is recommended for systems "closed" to atmospheric venting. Other piping accessories for filling, venting, or adjusting the fluid in the system, are recommended, but not included.

**Table 8 Pump data**

Pump Model	Connections		HP	Electric @ 60Hz				
	NPT Suction	Female Discharge		PH	208 FLA	230 FLA	460 FLA	575 FLA
3/4	1-1/4"	3/4"	3/4	1	7.6	6.9	N/A	N/A
3/4	1-1/4"	3/4"	3/4	3	3.5	3.2	1.6	1.3
1-1/2	1-1/4"	3/4"	1-1/2	3	6.6	6.0	3.0	2.4
2	1-1/4"	3/4"	2	3	7.5	6.8	3.4	2.7
3	1-1/2"	1"	3	3	10.6	9.6	4.8	3.9
5	1-1/2"	1-1/4"	5	3	16.7	15.2	7.6	6.1
7-1/2	3"	3"	7-1/2	3	24.2	22.0	11.0	9.0

To Calculate Total Pump and Drycooler Full Load Amps (FLA):

$$\text{Total FLA} = \text{Pump FLA} + \text{Drycooler FLA}$$

To Calculate Total Pump and Drycooler Wire Size Amps (WSA)

$$\text{Total WSA} = \text{Largest Motor FLA} \times 1.25 + \text{Sum of other Motor FLA values}$$

To Calculate Total Pump and Drycooler Maximum Overcurrent Protective Device (OPD)

$$\text{Total OPD} = \text{Largest Motor FLA} \times 4.0 + \text{Sum of other Motor FLA values}$$

Select standard fuse size (15A, 20A, 25A, 30A, etc.)

**Figure 11 Pump curve, 60 Hz**

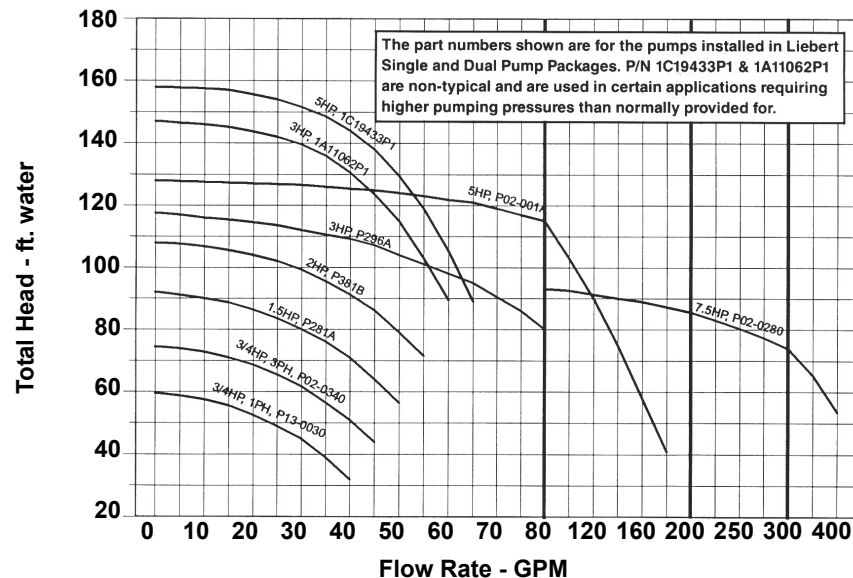

## SUPPLEMENTARY APPLICATION DATA

**Table 9 Room dew point temperatures**

Dry bulb °F (°C)	Wet bulb °F (°C)	Rel. hum. %	Dew point* °F (°C)
70	57.2	45	41.1
70	58.5	50	50.5
72	58.9	45	50.0
72	60.0	50	52.4
75	61.2	45	52.4
75	62.5	50	55.0

\* Minimum glycol temperature before condensation will occur

**Table 10 Glycol concentration at various ambients**

% Glycol by volume	0	10	20	30	40	50
Freezing point °F	32	25	16	5	-10	-32
Apparent specific gravity @50°F	1.000	1.014	1.028	1.042	1.057	1.071

**Table 11 Volume in standard tube**

Type "L" copper tube			
Diameter (in.)		Volume	
Outside	Inside	Gal/ft	(L/m)
.50	0.430	0.0075	(0.09)
.625	0.545	0.0121	(0.15)
.75	0.666	0.0181	(0.22)
.875	0.785	0.0251	(0.31)
1.125	1.025	0.0429	(0.53)
1.375	1.265	0.0653	(0.81)
1.625	1.505	0.0924	(1.15)
2.125	1.985	0.161	(2.00)
2.625	2.465	0.248	(3.08)
3.125	2.945	0.354	(4.40)
3.625	3.425	0.479	(5.95)
4.125	3.905	0.622	(7.73)

## MAINTENANCE GUIDELINES

Restricted airflow through the drycooler coil will reduce the operating efficiency of the unit and can result in high fluid temperatures and loss of cooling.

Clean the drycooler coil of all debris that will inhibit air flow. This can be done with compressed air or commercial coil cleaner.

Check for bent or damaged coil fins and repair as necessary. In winter, do not permit snow to accumulate around the sides or underneath the drycooler.

Check all fluid lines and capillaries for vibration isolation. Support as necessary.

Visually inspect all fluid lines for signs of fluid leaks.

Inspect the motor/fan assembly to insure bearings are (free) and motor is secure within the mount.

The glycol in drycooler systems level must be periodically checked. At the high point of the system check:

- For positive pressure.
- For air to be vented.
- For an unlogged expansion tank. A fluid sample for proper concentrations of anti-freeze and inhibitors.

The first three checks may give indication of leaks in the system.

### Important

When ordering replacement parts for heat rejection equipment, it is necessary to specify unit model number - serial number - voltage.

Enter this information below for future use.

\_\_\_\_\_

Model No.

\_\_\_\_\_

Serial No.

\_\_\_\_\_

Voltage



## HEAT REMOVAL/ENVIRONMENTAL CONTROL

# Drycoolers - 60 Hz

## GENERAL DATA

### The Company Behind the Products

With over a million installations around the globe, Liebert is the world leader in computer protection systems. Since its founding in 1965, Liebert has developed a complete range of support and protection systems for sensitive electronics:

- Environmental systems—close-control air conditioning from 1 to 60 tons
- Power conditioning and UPS with power ranges from 300 VA to more than 1000 kVA
- Integrated systems that provide both environmental and power protection in a single, flexible package
- Monitoring and control—from systems of any size or location, on-site or remote
- Service and support through more than 100 service centers around the world and a 24/7 Customer Response Center

While every precaution has been taken to ensure the accuracy and completeness of this literature, Liebert Corporation assumes no responsibility and disclaims all liability for damages resulting from use of this information or for any errors or omissions.

© 1994 Liebert Corporation  
All rights reserved throughout the world.  
Specifications subject to change without notice.

® Liebert and the Liebert logo are registered trademarks of Liebert Corporation. All names referred to are trademarks or registered trademarks of their respective owners.

SL-10058 (10/02)

### Technical Support

#### United States

1050 Dearborn Drive  
P.O. Box 29186  
Columbus, OH 43229

#### Single-Phase UPS

800-543-2378

#### Outside the United States

614-841-6598

#### 3-Phase UPS

800-543-2378

#### Environmental Control

800-543-2778

#### Italy

Via Leonardo Da Vinci 8  
Zona Industriale Tognana  
35028 Piove Di Sacco (PD)  
+39 049 9719 111  
FAX: +39 049 5841 257

#### Asia

23F, Allied Kajima Bldg.  
138 Gloucester Road  
Wanchai  
Hong Kong  
+852 2 572 2201  
FAX: +852 2 831 0114

#### Web Site

[www.liebert.com](http://www.liebert.com)

#### E-mail

[UPStech@liebert.com](mailto:UPStech@liebert.com)