

# Liebert® GXT3™

## Quick Start Guide – 5000-6000VA RT230 Models

The Liebert GXT3 is shipped with the following items:

- Terminal Block Communication terminals
- Compact disc with:
  - Liebert MultiLink®
  - Configuration program
  - User manual (electronic version)
- USB cable, one; 2m (6-1/2 ft.) long
- Rack handles with mounting hardware
- Plastic tower support base, one set
- Plastic Bezel
- Warnings, safety instructions booklet and WEEE recycling sheet (ISO 14001 compliance)

If the UPS is intended to be installed in the Tower orientation, locate the support base and spacers then assemble the two stand assemblies with an even number of spacers in each assembly. Insert the UPS between the support base assemblies with adequate space between the assemblies as shown in the picture below. *Note the display should be located on the upper half of the unit in the Tower orientation. To rotate the display with the bezels removed, depress the grooved tabs on the sides and rotate it 90 degrees clockwise.* If the USP is to be installed in a rack enclosure, follow the instructions provided with the rack mounting hardware for proper installation.

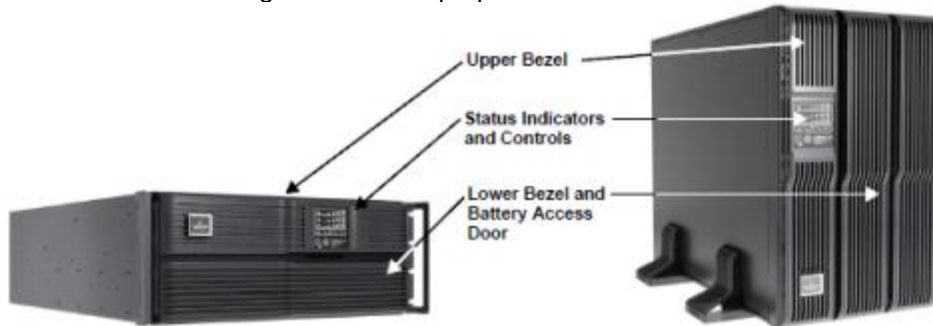

The UPS is hardwired input with a conduit entry knockouts provided. Input and output wiring should be installed in separate conduits. All wiring should be done in accordance to all local and national electrical codes. Before wiring the UPS ensure that the breaker in the external upstream panelboard is OFF.

UPS Model	Recommended (Maximum) External Over Current Protection	Recommended Wire (All wires) 75 degC Copper Wire	Maximum Wire Accepted by Terminal Block	Terminal Block Torque
GXT3-5000RT230 GXT3-6000RT230	32A	4mm <sup>2</sup> (10 AWG)	6mm <sup>2</sup> (8 AWG)	2.26 Nm (20 in-lb)

### Terminal Block Connections

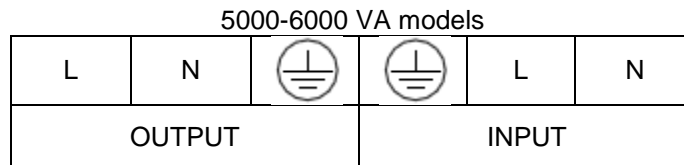

The UPS is equipped with a POD containing output receptacles; connect the equipment to be protected to the output receptacles.

The Liebert® GXT3™ 5000-6000 VA RT230 models are compatible with IT Power Systems. To configure the unit for operation on the IT Power system, remove the 2 screws securing the cover plate in the lower right hand side on the rear of the unit and disconnect the jumper, then replace the cover and secure with the screws.

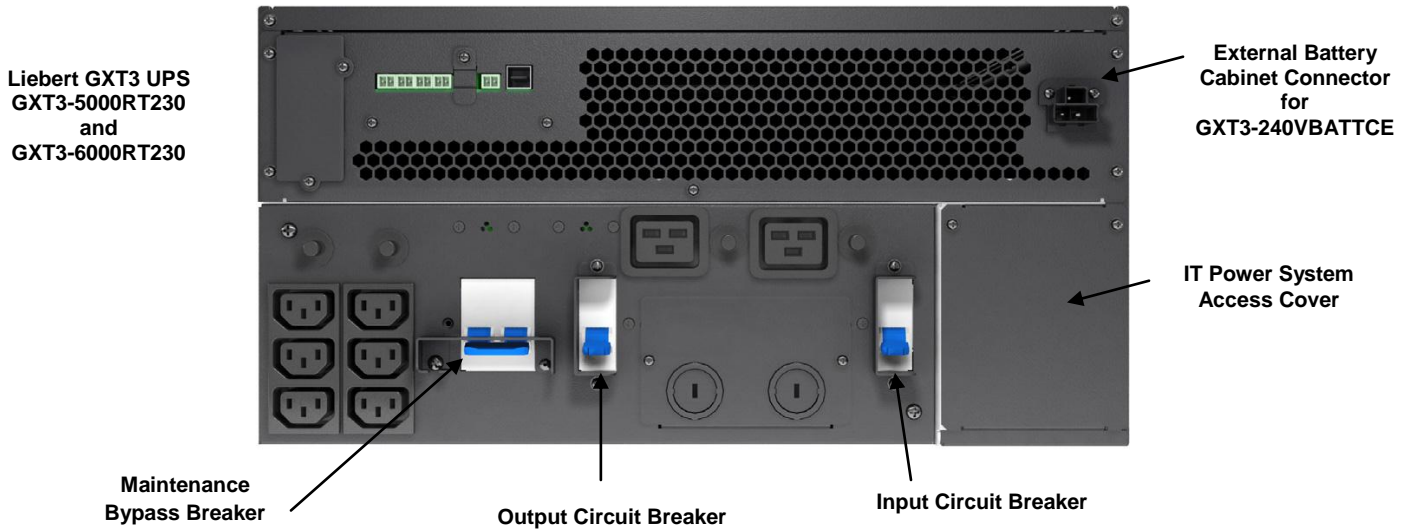

The Liebert® GXT3™ UPS is ready to be powered.

1. Locate the plastic bezel from the shipping box and attach the bezel to the UPS taking care to align the fastening clips on both ends before inserting them into the holes.
2. If your application requires the use of external battery cabinets for longer back up time requirements, connect the first battery cabinet to the UPS with the cable provided with the battery cabinet. *Note: Either connector is acceptable to connect the external battery cabinet.* If more than one battery cabinet is used the additional cabinets then connect to the previously connected battery cabinet.
3. Ensure the maintenance bypass breaker is in the open position and that the guard is secured in place.
4. Ensure that the REPO connector on the rear of the unit has a jumper between pins 1-2 of the REPO connector or properly wired to an Emergency Power Off circuit (normally closed).
5. Install any optional Intellislot communication card into the Intellislot port on the rear of the unit.
6. Close the input breaker in the panelboard that provides input power to the UPS
7. Close the input breaker on the rear of the UPS unit. *Note: The UPS will now have power and the AC Input indicator on the display will illuminate. The UPS will begin to charge the internal batteries causing the battery capacity LEDs to illuminate.*
8. The Liebert GXT3 UPS has customizable settings that might be required depending on the application. Please review the CD that ships with the UPS unit for the steps to use the configuration program and make any necessary changes. Once that is complete, proceed to the next step.
9. Close all output breakers on the rear of the UPS
10. If external battery cabinets are used, close all breakers on the rear of each battery cabinet
11. Press and hold for about 4 seconds, the "ON" button on the UPS display. *Note: this will apply power to the output receptacles via the internal bypass. The bypass indicator will be illuminated along with an audible beep during this time.*
12. Over the next several seconds the UPS will perform the self checks and then automatically transfer the connected equipment to conditioned power. Once that is complete, the bypass indicator will turn off and the inverter indicator will illuminate.

The UPS is now running in normal operation mode providing protected, filtered power to the connected equipment.

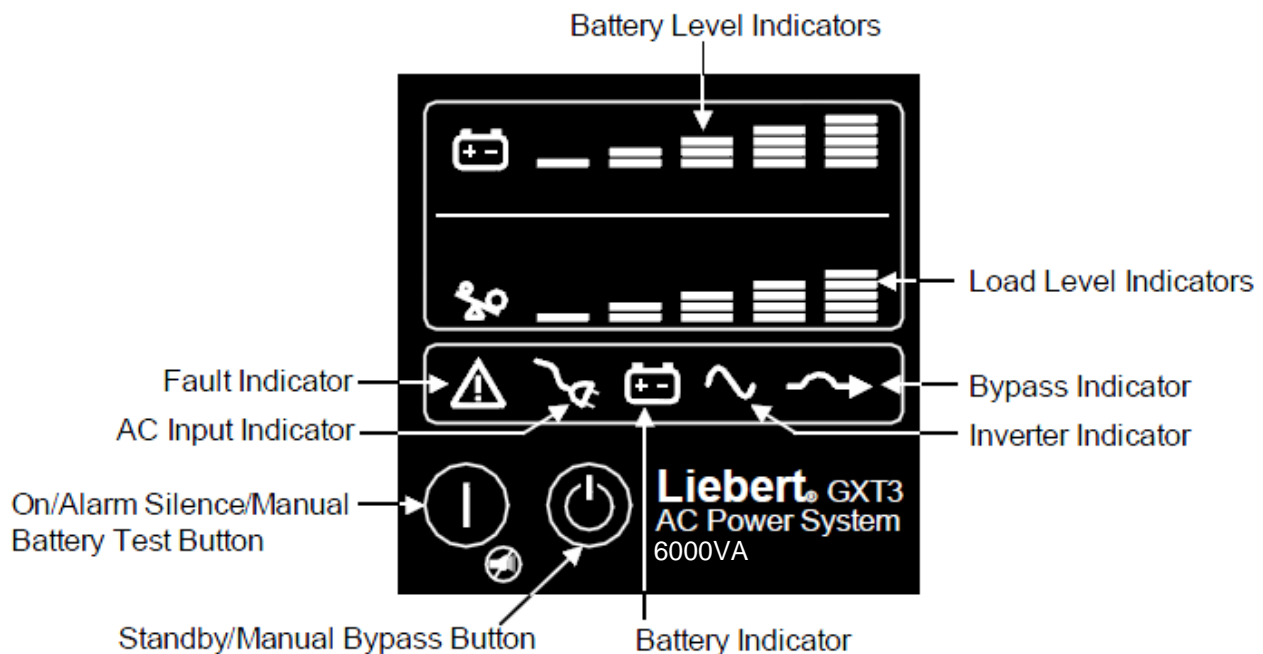

## Troubleshooting

The following symptoms indicate the Liebert® GXT3™ is malfunctioning:

- The relative indicators illuminate, indicating the UPS has detected a problem.
- An alarm buzzer sounds, alerting the user that the UPS requires attention.

In addition to the fault indicator being illuminated, one or more of LED segments of battery level indicator will also be illuminated to provide a diagnostic aid to the user, as shown below



The descriptions are listed in the following table

Indicator	Diagnosis/Audible alarm
A - E	On bypass from output overload (half-second beep every half-second)
A	On bypass due to over temperature condition (1-second beep every 4 seconds)
B	On bypass due to DC bus overvoltage (1-second beep every 4 seconds)
C	On bypass due to DC/DC power supply failure (1-second beep every 4 seconds)
D	PFC failure (1-second beep every 4 seconds)
E	On bypass due to inverter failure (1-second beep every 4 seconds)
A&B	UPS Failure (includes dual-fan failure, single-fan failure under certain conditions and battery charger failure) and continuous alarm
A&C	UPS failed battery test (2-second beep every 60 seconds)
A&D	Maintenance bypass switch on (continuous)
A&E	Bypass feedback (1-second beep every 4 seconds)
B&C	REPO (one quarter-second beep at quarter-second intervals)
B&E	Short circuit on the output
C&E	UPS shutdown by command from communication (USB or Liebert IntelliSlot® port) (no audible alarm)
AC Input Indicator LED flashing	L-N reverse
Battery Indicator Flashing	Internal battery source not available (continuous audible alarm); check battery connection, power down and reboot UPS
Bypass Indicator Flashing	Utility power voltage or frequency is out of tolerance; bypass is unavailable

### Single-Phase UPS & Server Cabinets Technical Support

liebert.upstech@emerson.com

800-222-5877

Outside North America: +00800 1155 4499

### Emerson Network Power Worldwide Locations

#### United States

1050 Dearborn Drive  
P.O. Box 29186  
Columbus, OH 43229  
800-222-5877

#### Asia

29/F, The Orient Square Building  
F. Ortigas Jr. Road, Ortigas Center  
Pasig City 1605  
Philippines  
+63 2 687 6615  
Fax: +63 2 730 9572

#### Europe

Via Leonardo Da Vinci 8  
Zona Industriale Tognana  
35028 Piove Di Sacco (PD) Italy  
+39 049 9719 111  
Fax: +39 049 5841 257