

LifeFitness

ARCTIC SILVER 95T-XXXX-07 TREADMILL

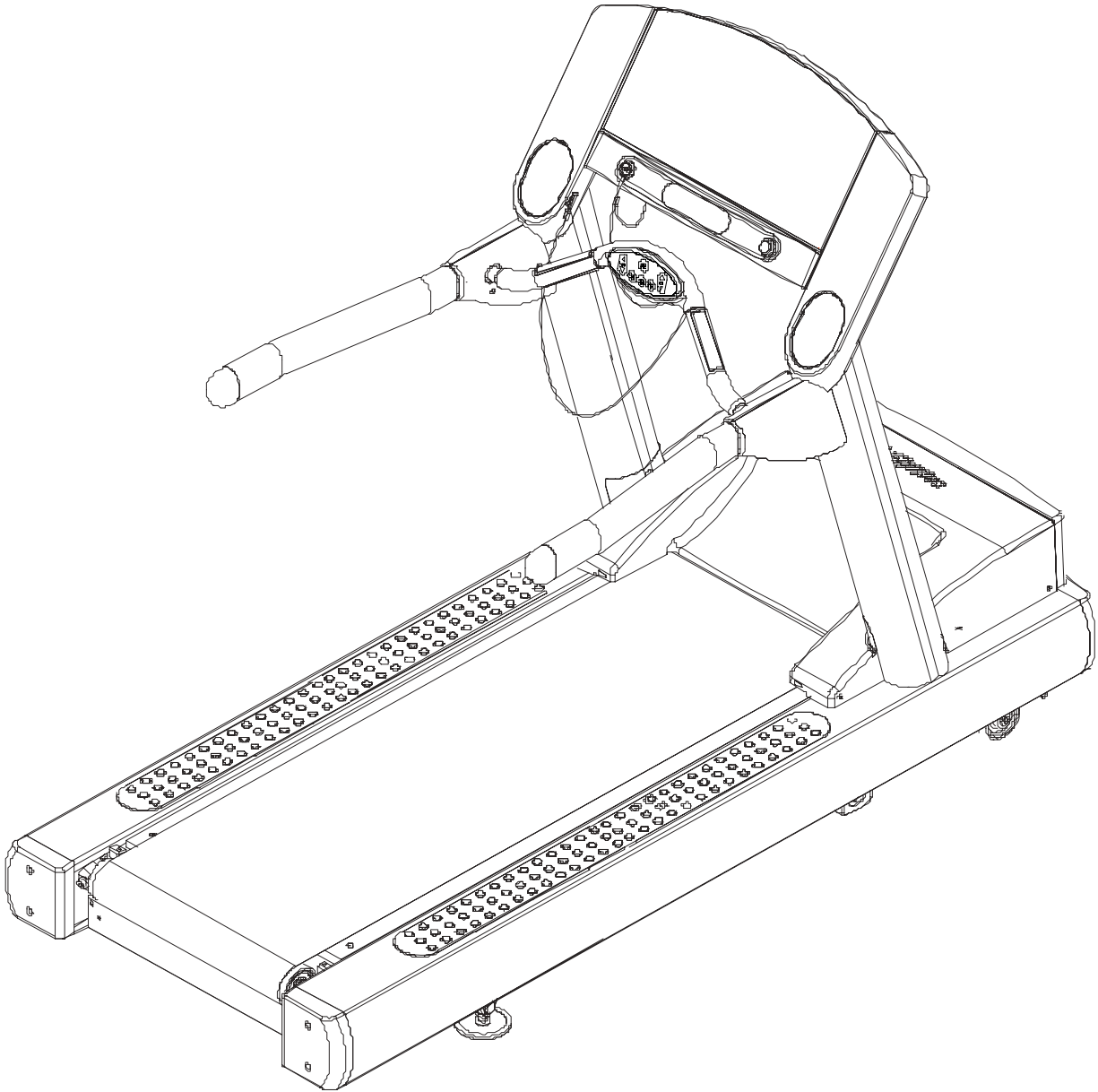

Customer Support Services ***PARTS MANUAL*** rev 29 May 2008

	Page
REFERENCES	3
CONSOLE, OVERLAY ASSEMBLY & OVERLAY	5
CONSOLE COMPONENTS	6
UPRIGHTS & HANDRAILS.....	7
ERGO BAR, HEART RATE SENSORS & ACTIVITY ZONE	8
A-Z MODULE WITH OVERLAY ASSY	9
REAR ENDCAPS & CUP HOLDERS	10
MOTOR COVER, FRONT COVER & ENDCAPS.....	11
SCUFF PAD & TINSEL	12
ON-OFF SWITCH, ACCESS PLATE & GROMMETS	13
BELT, DECK & REAR ROLLER.....	14
LIFT FRAME, LIFT MOTOR & IEC RECEPTACLE.....	15
IDLER ARM ASSEMBLY	16
LEG LEVELER ASSEMBLY	17
FRONT ROLLER ASSEMBLY.....	18
DRIVE MOTOR ASSEMBLY	19
STRIDE SENSOR ASSY & STRIDE SENSOR PCB ASSY.....	20
DSP-CONTROLLER ASSEMBLY	21
LINE-CORDS & LINE-CORD OPTIONS	22
BLOCK DIAGRAM - CONSOLE VIEW	23
BLOCK DIAGRAM - DSP VIEW	24
BLOCK DIAGRAM - LINE FILTER VIEW	25

LANGUAGE	OPERATION MANUAL	INSTRUCTION ASSEMBLY	INSTRUCTION BAG ASSY.	SERVICE MANUAL
ENGLISH	M051-00K58-A272	M051-00K58-A322	AK58-00578-0000	M051-00K58-A253
FRENCH	M051-00K58-A273	M051-00K58-A323	AK58-00578-0001	
PORTUGUESE				
SPANISH				
DUTCH	M051-00K58-A274	M051-00K58-A324	AK58-00578-0002	
GERMAN				
ITALIAN				
JAPANESE	M051-00K58-A275	M051-00K58-A325	AK58-00578-0003	
EUR	M051-00K58-A272	M051-00K58-A322	AK58-00578-0004	

*All Operation, Instruction Assembly & Instruction Bag Assembly may not be available

AK58-00226-0000	Hardware Bag Assembly: MFG;95T/97T	
Item	Description	Qty
OK58-01305-0002	PLUG: UPRIGHT S/C-C	2
OK58-01347-0000	GASKET: ERGOBAR C	2
0017-00009-1049	WRENCH: TORX; T27 B	1
0017-00042-0326	GROMMET: PLASTI; .130/.005 S/C#13-B	2
0017-00042-0840	CLIP: WIRE; PUSH-MTG; 3/4"; S/C#80-B	5
0017-00101-1770	8-15X 8 PHL PAN A SS NO B	6
0017-00101-1772	10-16X 8 PHL PAN B ST ZS B	6
0017-00101-1773	1/4 -20X 8 TRX BUT CS SS NO B	6
0017-00101-1774	5/16-18X40 TRX FLT CS ST ZS B	4
0017-00101-1778	1/2 -13X16 UNS HEX CS G5 ZB B	4
0017-00101-1780	8- X20 PHL TRS AB SS NO B	8
0017-00104-0325	WSH 516-.873-125 SL-D ST ZN B	4
0017-00103-0327	NUT 5/16-18 HEX; JAM D ST ZS B	4

ARCTIC SILVER 95T
CONTENTS

95T-XXXX-07
S/N TSS100000 and up

GK58-00002-0095 KIT: SERV; ROLLER-GUARDS; 93/95Ti BM		
Part Number	Description	Qty
AK58-00360-0001	GUARD-ASSY: MFG; RT; 3.50 B	1
AK58-00360-0002	GUARD-ASSY: MFG; LT; 3.50 B	1
M051-00K58-B128	INSTR: SERV; ROLLER-GUARDS +	1
0017-00042-0326	GROMMET: PLASTI; .130/.005 S/C#13-B	2
0017-00042-1147	GROMMET: NYLON; SCREW B	2
0017-00101-1776	10-16X 8 PHL PAN B ST ZB B	4

GK58-00002-0071 KIT: SERV; ANTI-SLIP RAIL BM		
Part Number	Description	Qty
Only available in the kit	INSTR:TEMPLT; ANTI-SLIP RAIL B	4
Only available in the kit	INSTR: KIT; ANTI-SLIP RAIL +	1
OK58-01376-0000	RAIL: ANTI-SLIP;STEALTH-GREY E	2
Only available in the kit	PAD: WIPE; ALCOHOL/DRY B	

TOUCH UP PAINT:	
0017-00008-0204	PAINT: CAN; SPRAY; ARCTIC SILVER
0017-00008-0205	PAINT: BOTTLE; ARCTIC SILVER (.5 OZ)
0017-00008-0206	PAINT: PEN; ARCTIC SILVER (.33 OZ)

INK TRANSFER TOUCH-UP PAINT: SB No. GN05032101N	
0017-00008-0210	PAINT: TOUCH-UP; SHADOW-GRAY; .6 OZ BTL.
0017-00008-0211	PAINT: TOUCH-UP; SHADOW-GRAY; .6 OZ. PEN

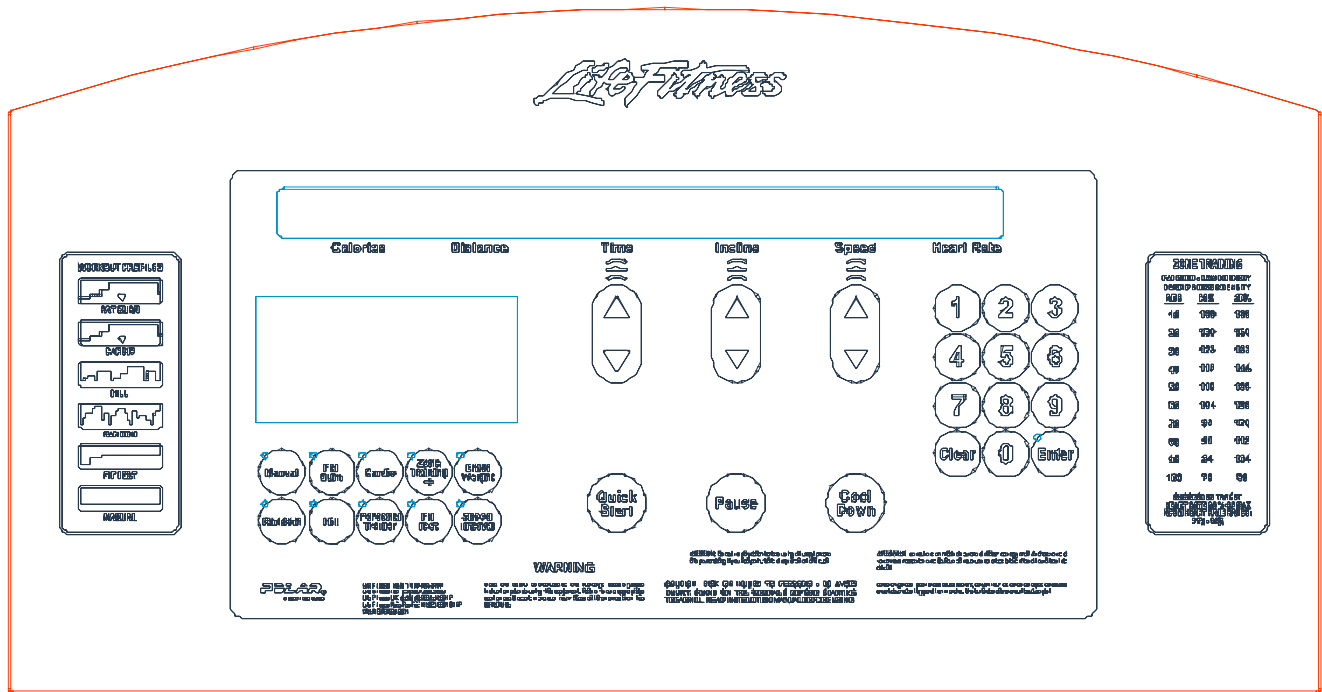

LANGUAGE	CONSOLE	OVERLAY/BEZEL ASSY	OVERLAY
ENG/ENG	AK58-00580-0001	AK58-00203-0001	OK58-01298-0001
ENG+MET	AK58-00580-0002	AK58-00203-0002	OK58-01298-0001
GERMAN	AK58-00580-0003	AK58-00203-0003	OK58-01298-0003
SPANISH	AK58-00580-0004	AK58-00203-0004	OK58-01298-0004
JAPANESE	AK58-00582-0006	AK58-00202-0006	OK58-01296-0006
FRENCH	AK58-00580-0007	AK58-00203-0007	OK58-01298-0007
ITALIAN	AK58-00580-0008	AK58-00203-0008	OK58-01298-0008
DUTCH	AK58-00580-0009	AK58-00203-0009	OK58-01298-0009
PORTUGUESE	AK58-00580-0010	AK58-00203-0010	OK58-01298-0010

*All Console, Overlay/Bezel Assembly or Overlay may not be available

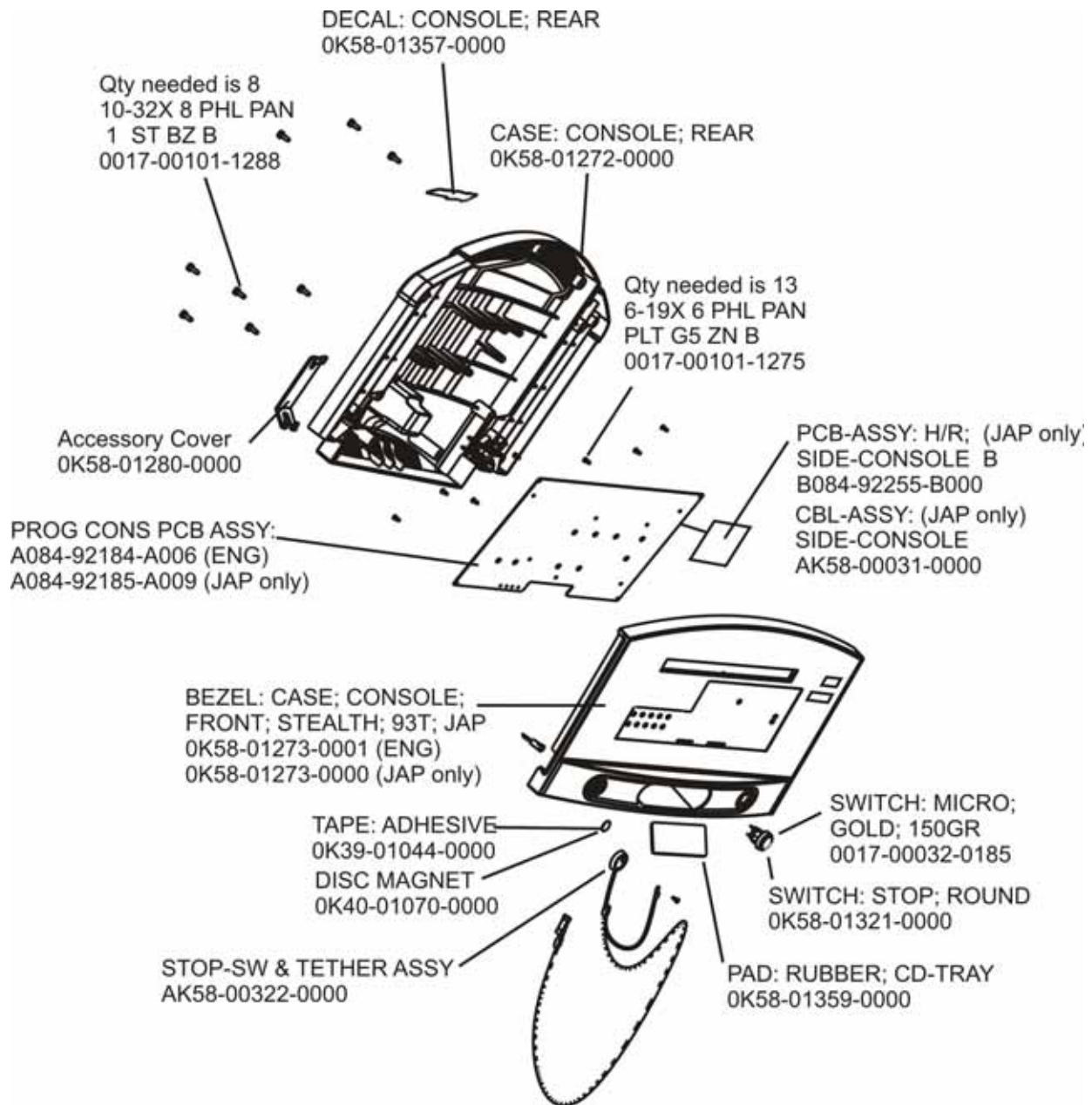

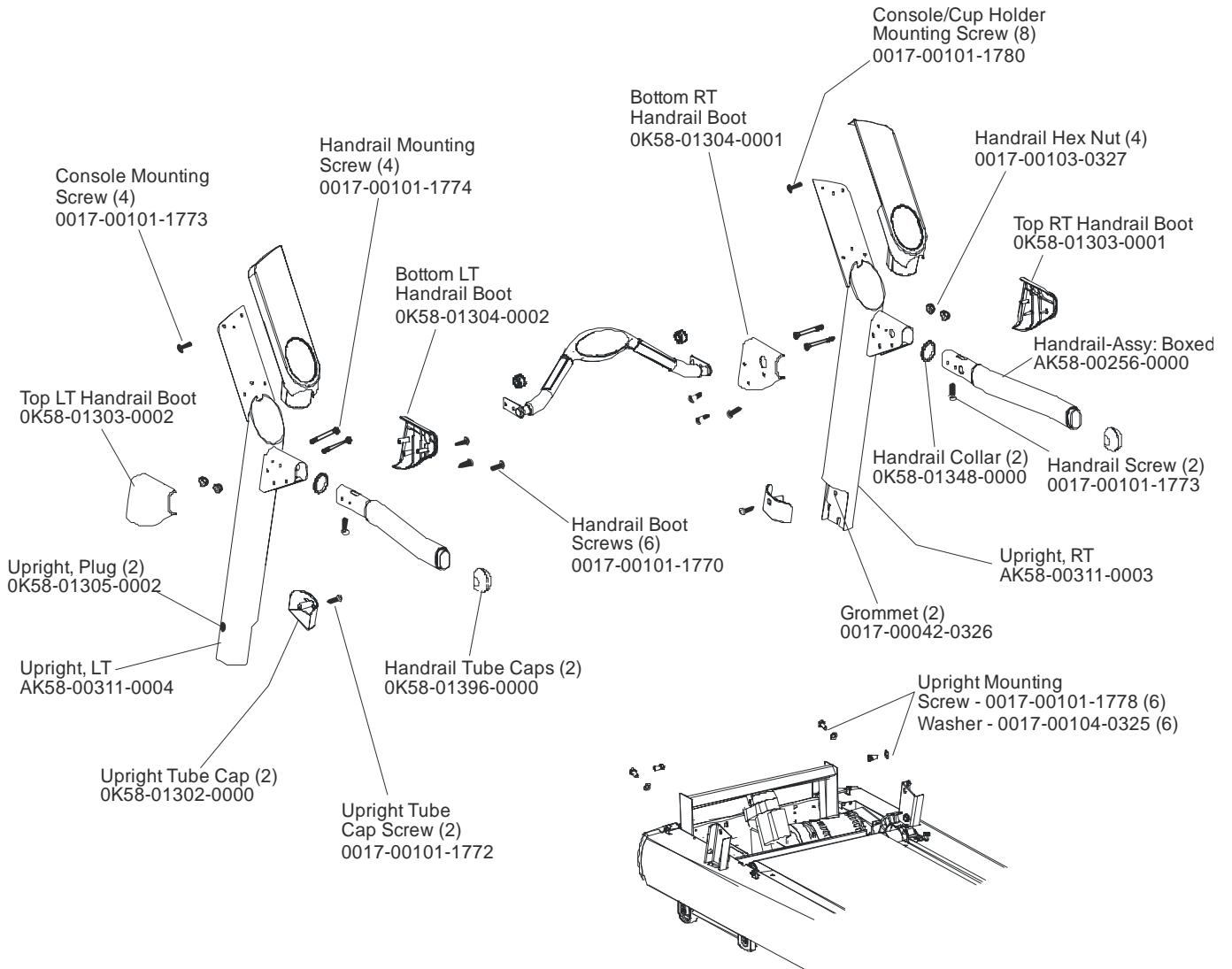

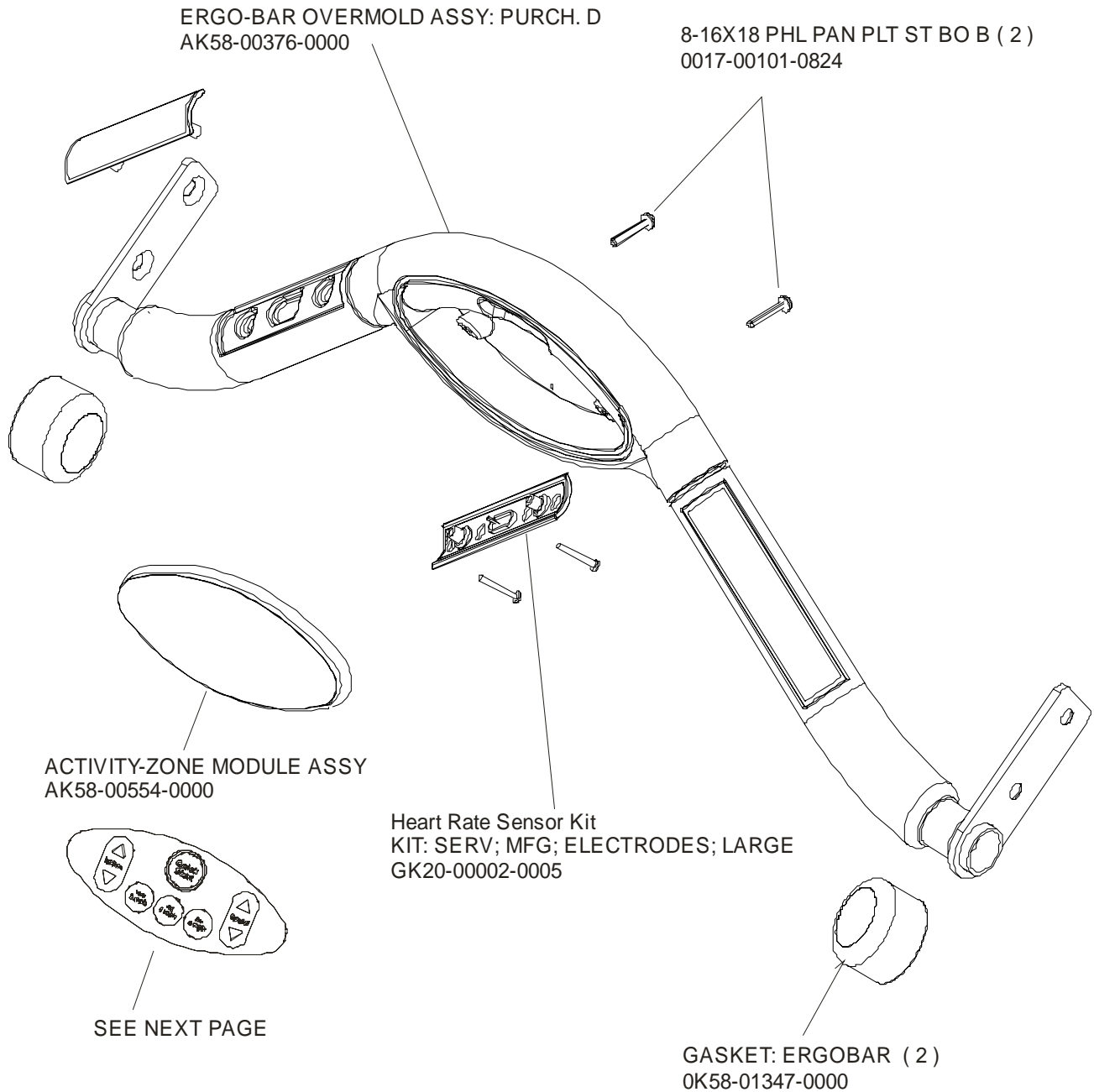

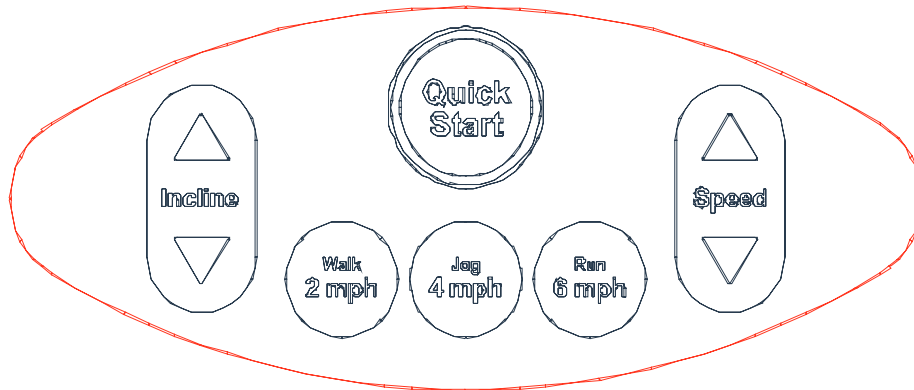

LANGUAGE	ACTIVITY ZONE ASSY	AZ OVERLAY
ENG/ENG	AK58-00555-0001	OK58-01459-0001
ENG/MET	AK58-00555-0002	OK58-01459-0002
GERMAN	AK58-00555-0003	OK58-01459-0003
SPANISH	AK58-00555-0004	OK58-01459-0004
JAPANESE	AK58-00555-0006	OK58-01459-0006
FRENCH	AK58-00555-0007	OK58-01459-0007
ITALIAN	AK58-00555-0008	OK58-01459-0008
DUTCH	AK58-00555-0009	OK58-01459-0009

*All Activity-Zones Overlays may not be available

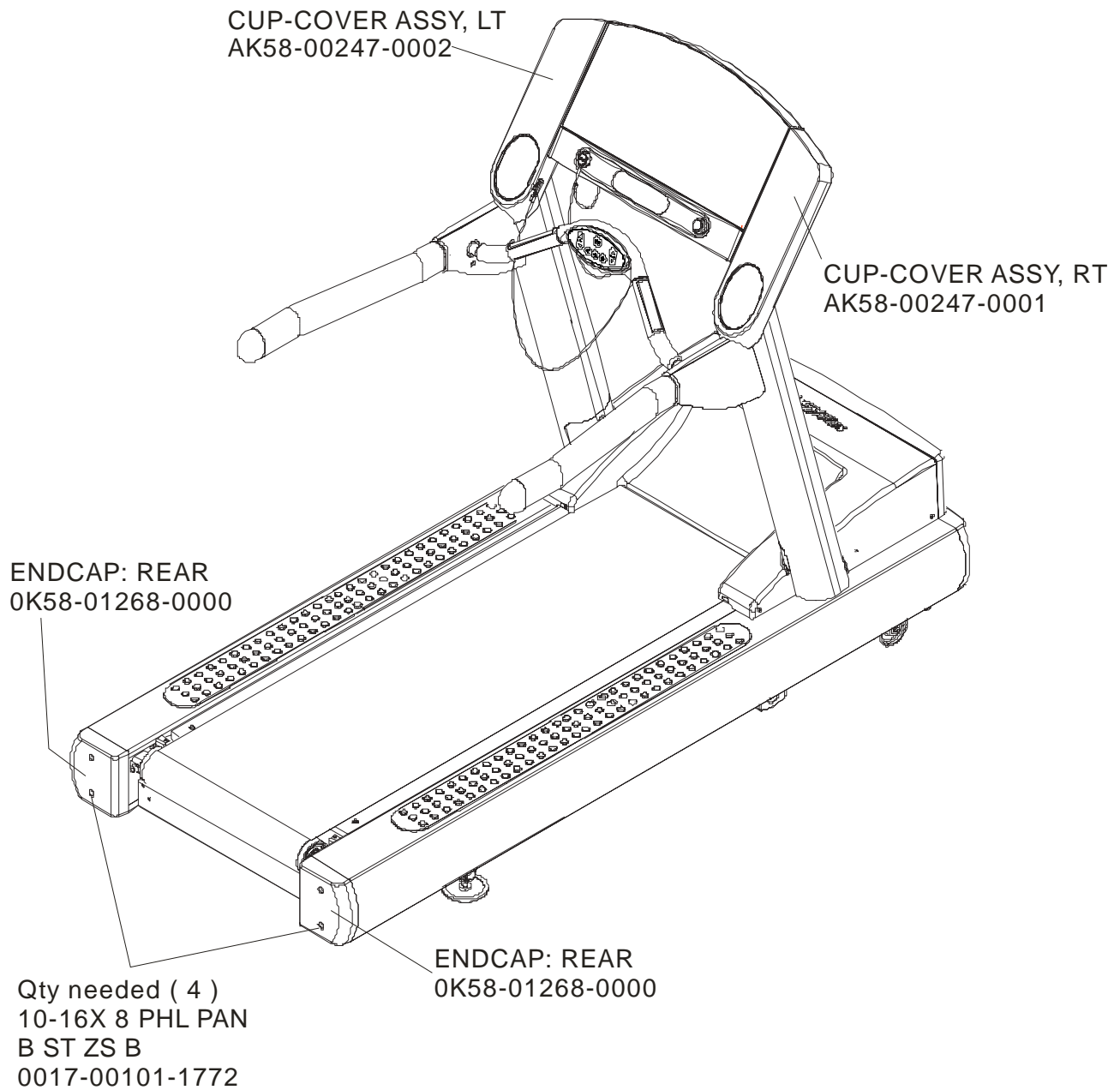

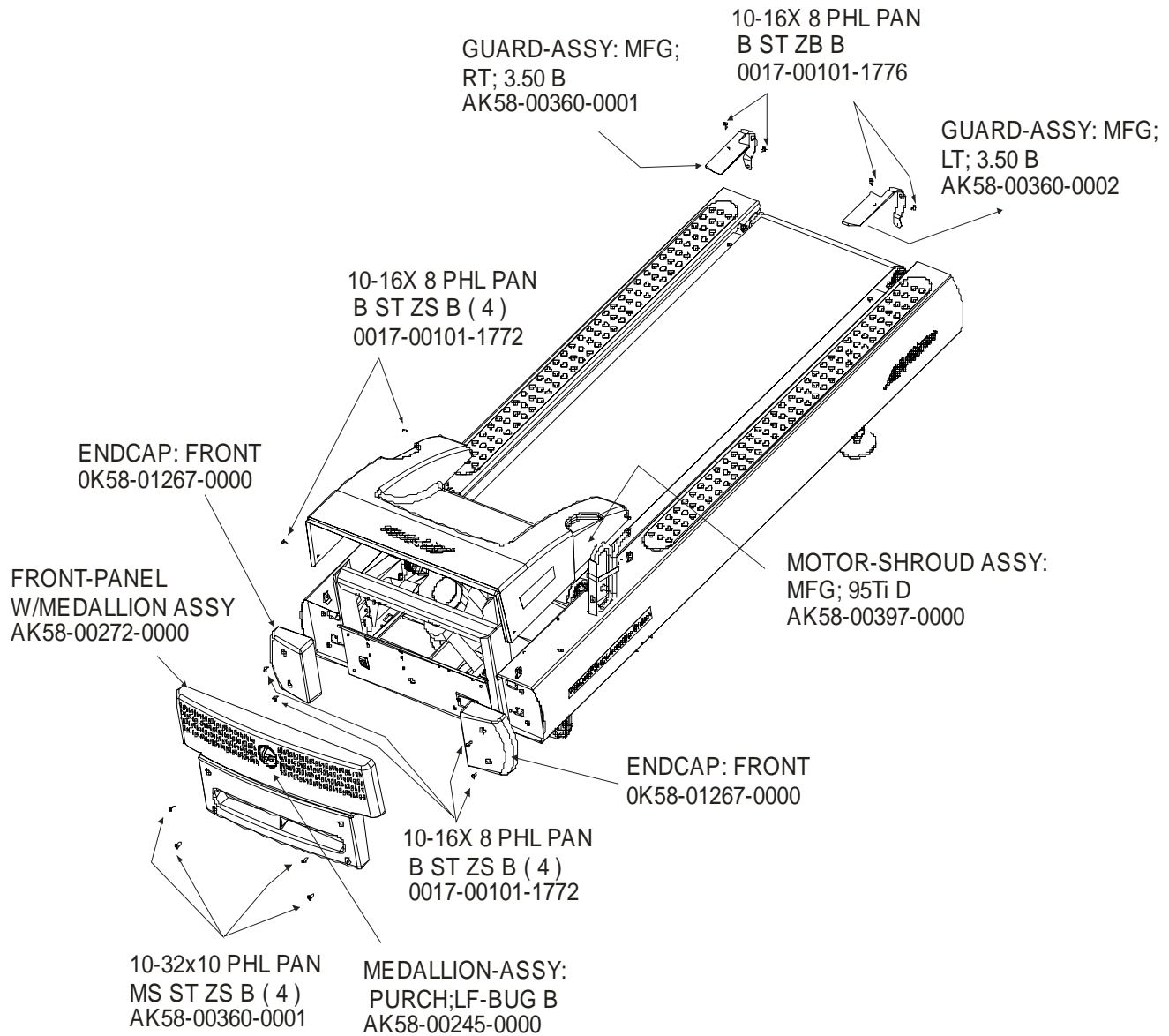

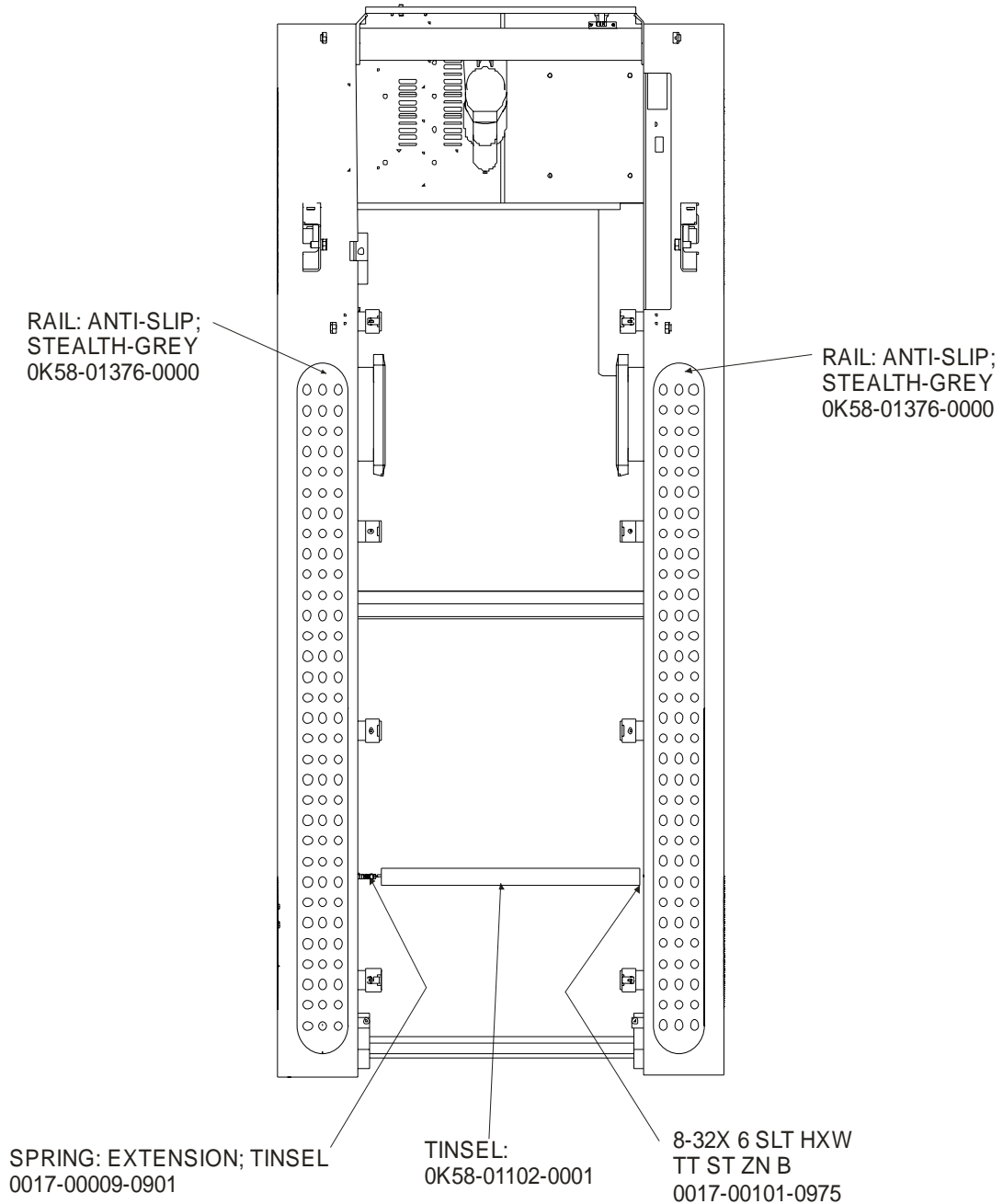

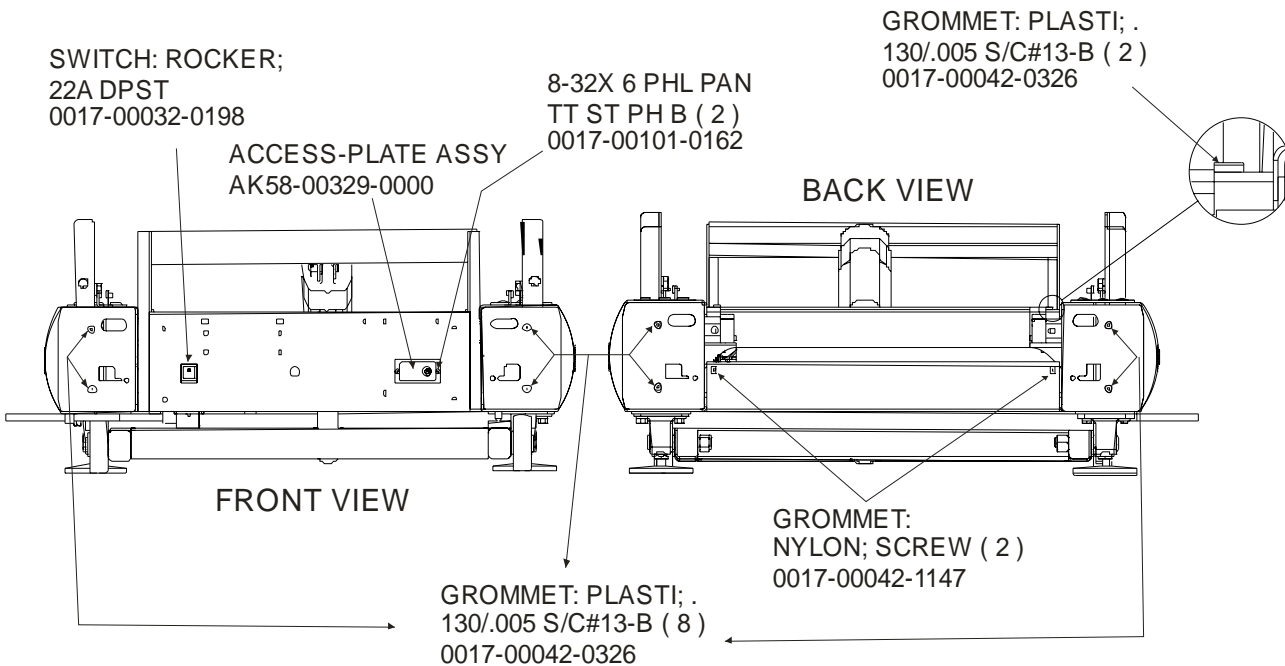
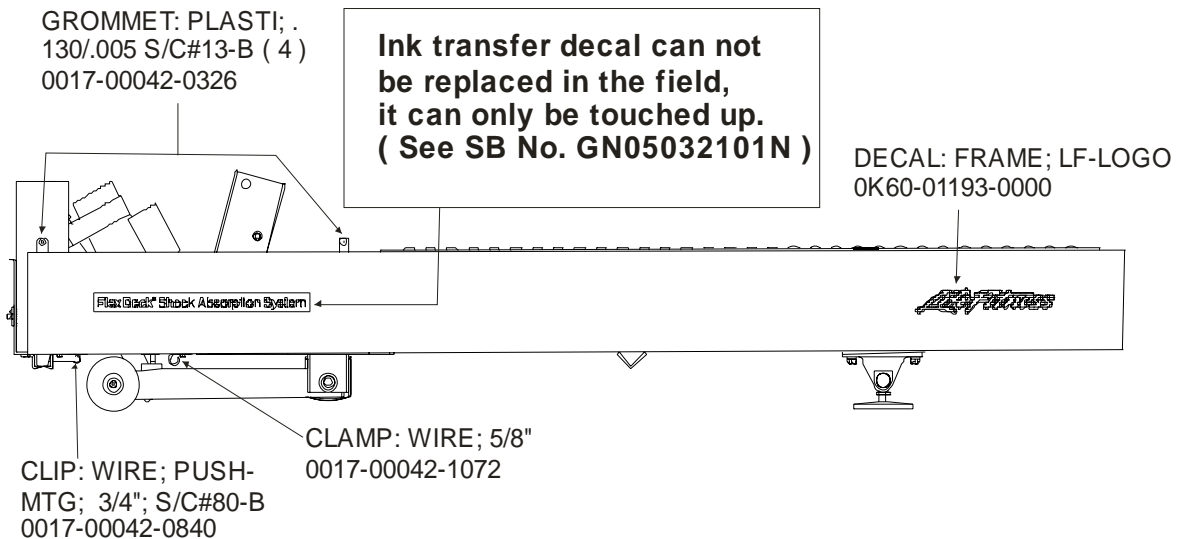

ARCTIC SILVER 95T
Belt, Deck & Rear Roller

95T-XXXX-07
S/N TSS100000 and up

BELT: WALKING; BLK;
 W/LOGO; NP7131 C
 0K58-01400-0000

LBL: BELT-LIMIT; LT.
 M051-00K58-A101

DECK: TREADMILL; WAXLESS
 0K58-01091-0002

1/4 -20x20 HXS FLT L
 CS ST ZB B (4)
 0017-00101-1775

NUT 1/4 -20 TINNEMAN
 D ST ZN B (4)
 0017-00103-0198

LBL: CAUTION;
 HI-VOLT;ENG+FRN B
 M051-00K58-A014

LBL: BELT-LIMIT; RT.
 M051-00K58-A100

SPRING: TECSPAK,
 BLACK S/C-B (8)
 0K40-01026-0002

1/4 -20X16 HXS BUT
 L CS G8 BO B (8)
 0017-00101-1652

WSH 255-.562-046
 FL-D ST ZN B (8)
 0017-00104-0072

ROLLER: REAR; 3.5"
 0K58-01002-0000

Rear Roller Adjusting Bolt (2)
 3/8 -16X48 HEX SOC L CS ST SS B
 0017-00101-1880

ARCTIC SILVER 95T

Lift Frame , Lift Motor & IEC Receptacle

95T-XXXX-07

S/N TSS100000 and up

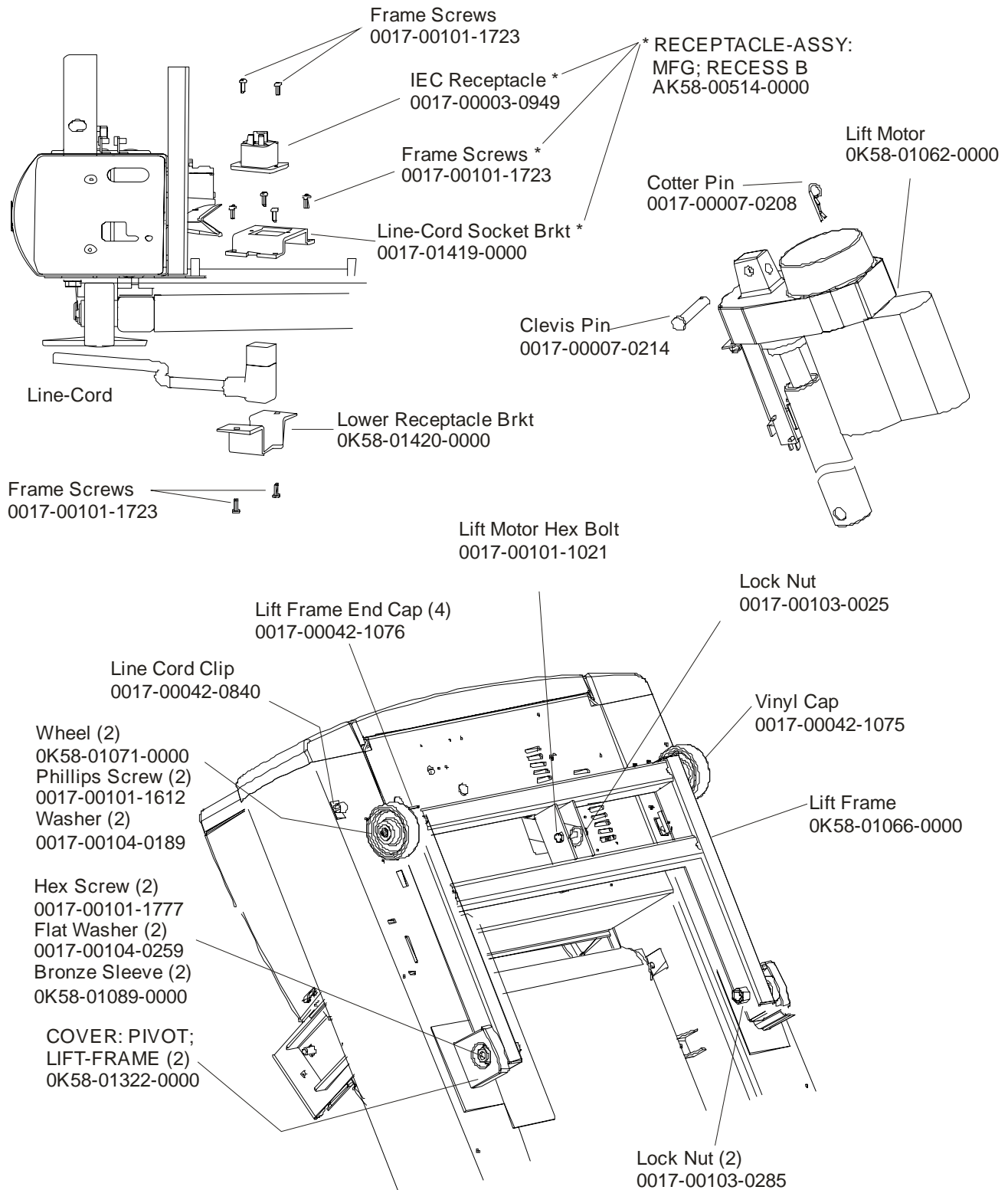

ARCTIC SILVER 95T
Idler Arm Assembly

95T-XXXX-07
S/N TSS100000 and up

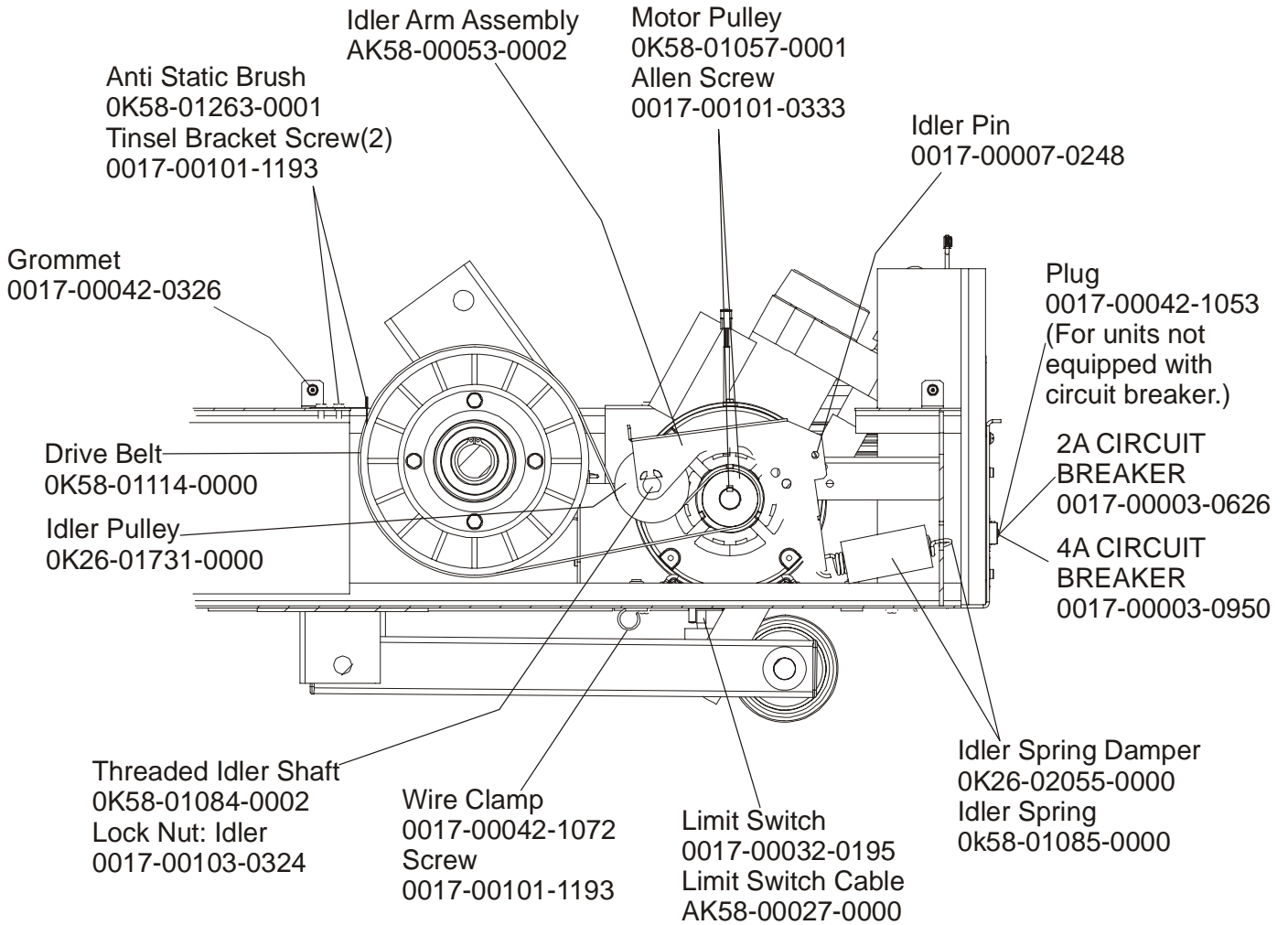

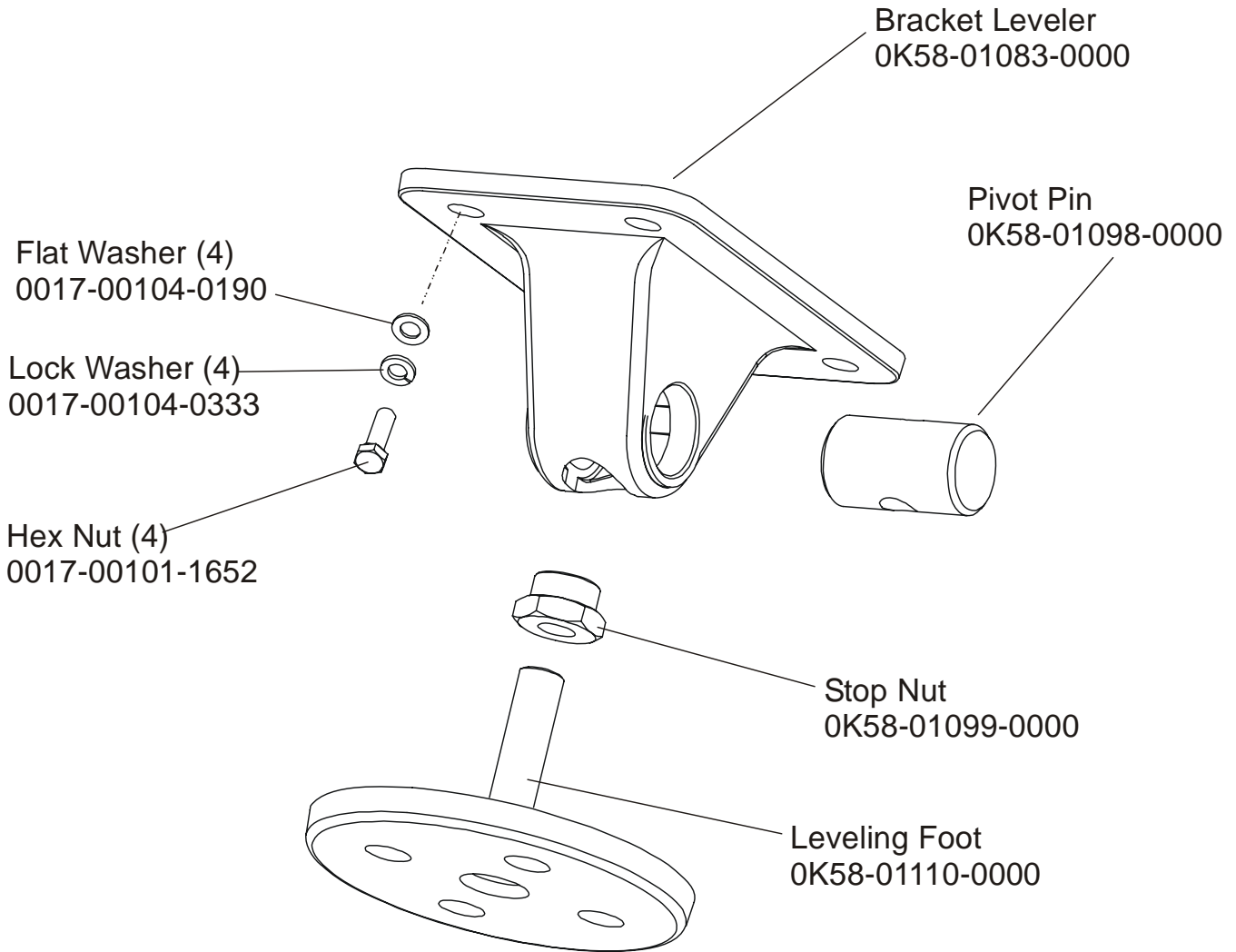

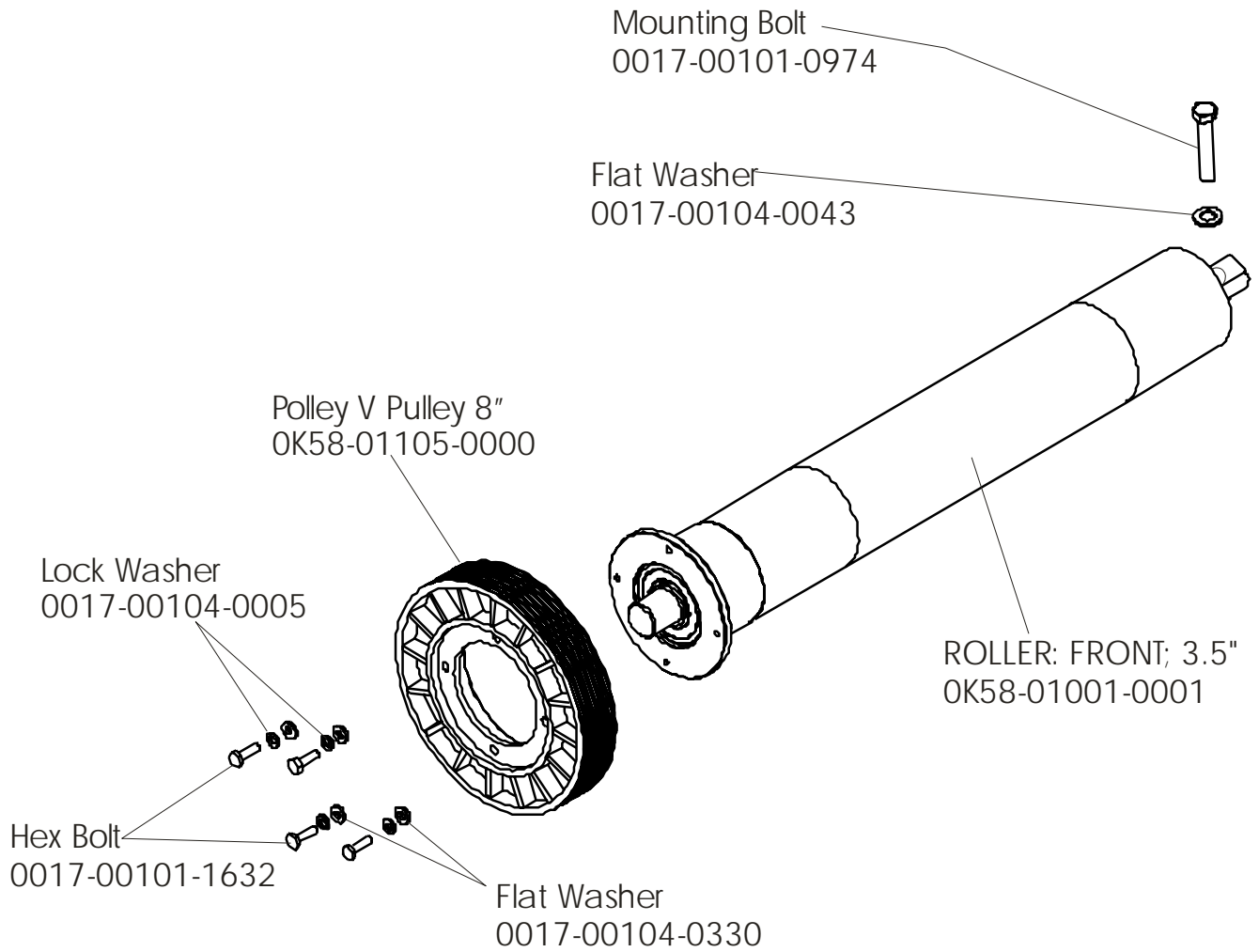

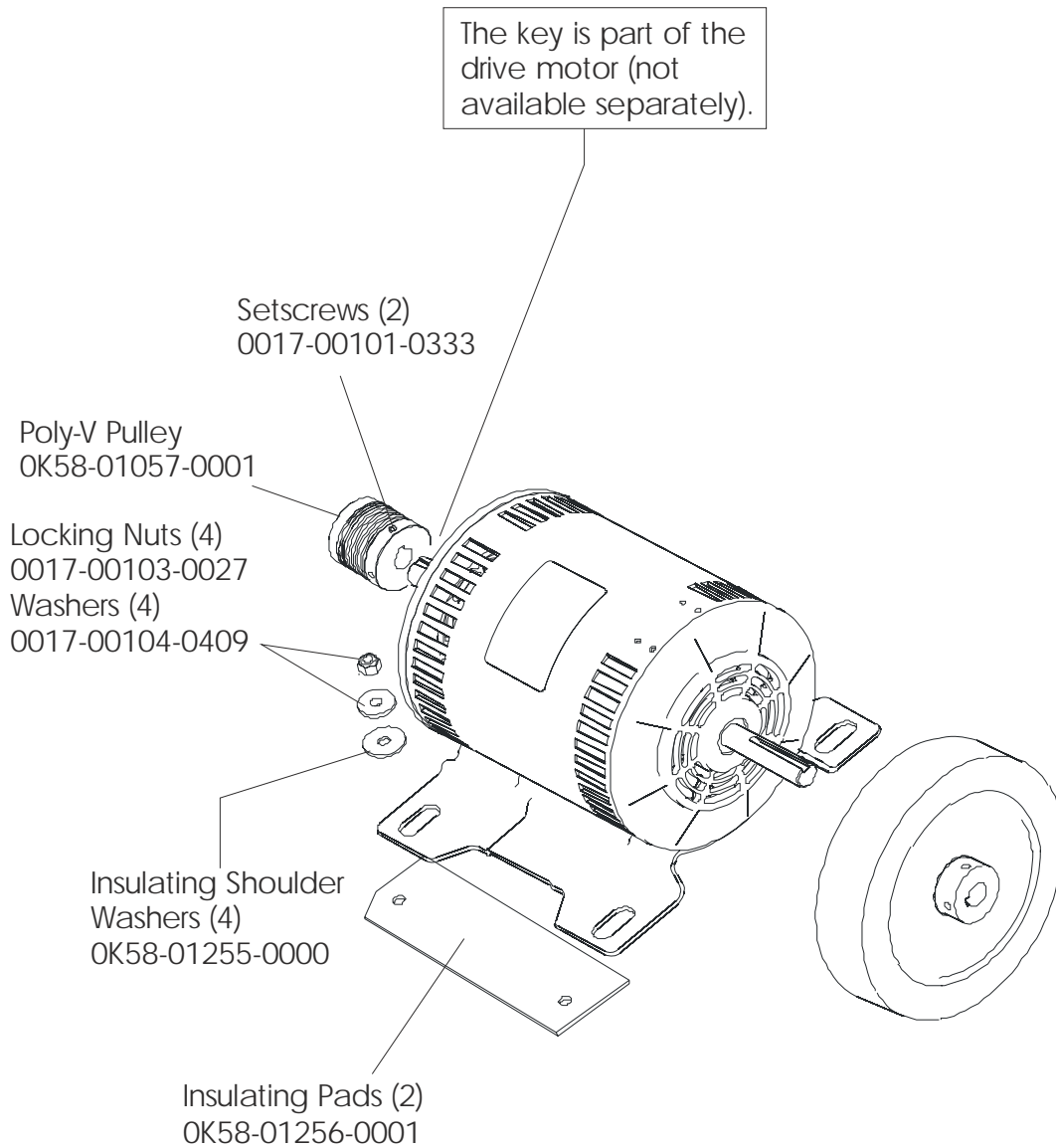

Description	Part Nos.	
	S/N TSS100000–TSS102326	S/N TSS102327 and up
Drive Motor Assembly	AK58-00171-0001 (dual cable)	AK58-00171-0002 (tapered shaft)
Cast Iron Flywheel	OK58-01092-0002	OK58-01092-0004
Drive Motor Setscrews/Bolt	0017-00101-0975 (uses setscrews)	0017-00101-1885 (uses bolt)

Ref: technical bulletin TR07060101N

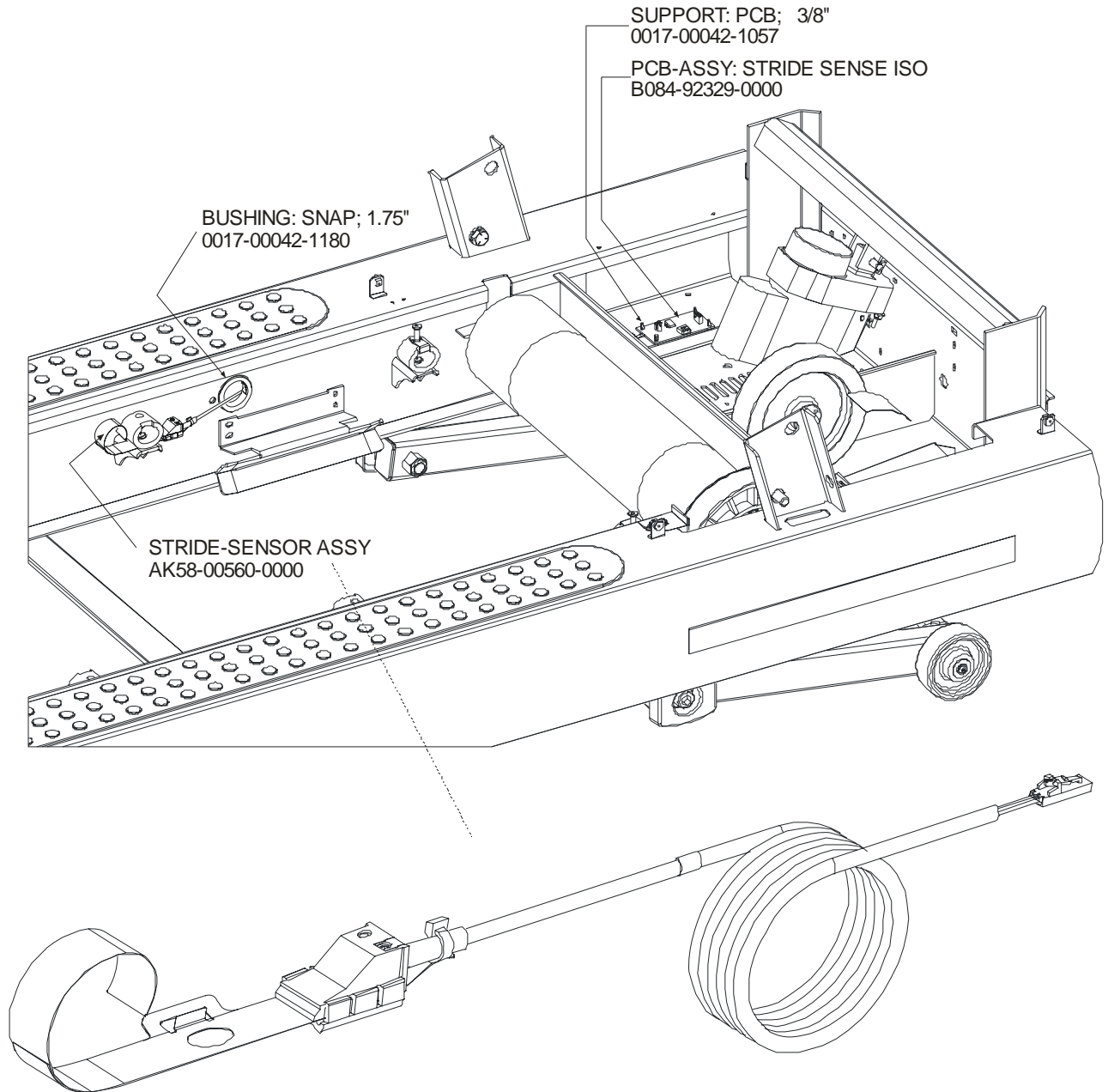

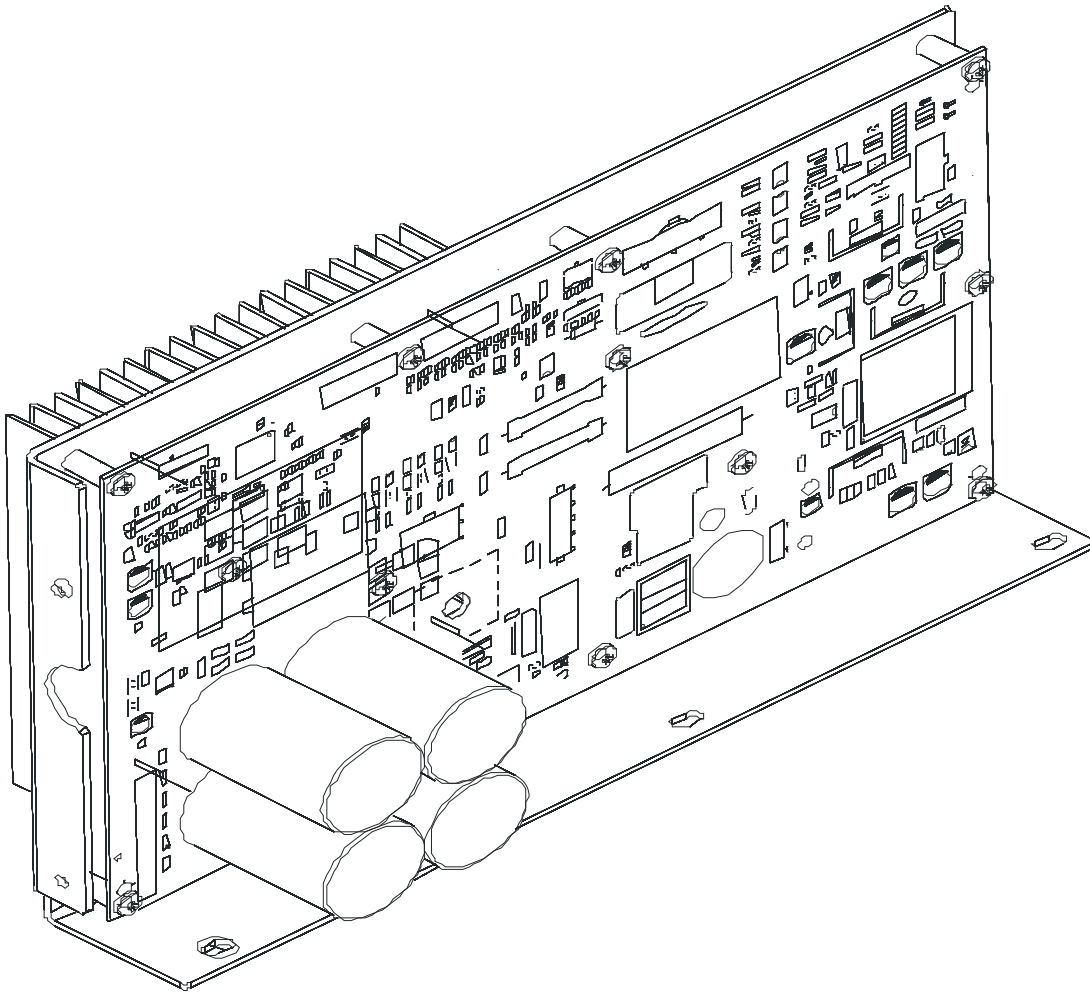

VOLTAGE	PART NUMBER	PART DESCRIPTION
100-120	GK58-00002-0118	KIT: SERV; MFG; DSP CONTROLLER 100-120; LED
200-240	GK58-00002-0120	KIT: SERV; MFG; DSP CONTROLLER 200-240; LED

ARCTIC SILVER 95T

95T-XXXX-07

Circuit Breaker, Line Cords & Line Cord Options

S/N TSS100000 and up

MODEL #	MODEL DESCRIPTION	STANDARD LINE CORDS
95T-0100-02	95T ENG/ENG 120/60 DOM	0017-00003-0974 LINE-CORD: R/A; 96"; W/RECP S/C-C
95T-0300-02	95T FRN/MET 120/60 DOM	
95T-0400-02	95T SPN/MET 120/60 DOM	
95T-0800-02	95T POR/MET 120/60 DOM	
95T-0103-02	95T ENG+MET 220/60 DOM	0017-00003-0781 LINE-CORD: R/A; 220V; USA D
95T-0105-02	95T ENG+MET 100/50 DOM	
95T-0106-02	95T ENG+MET 200/50 DOM	
95T-0705-02	95T JAP/MET 100/50 DOM	
95T-0706-02	95T JAP/MET 200/50 DOM	
95T-0101-02	95T ENG+MET 230/50 CON	0017-00003-0696 LINE-CORD: R/A; CEE7; 103" 10A 250V D
95T-0201-02	95T GER/MET 230/50 CON	
95T-0301-02	95T FRN/MET 230/50 CON	
95T-0401-02	95T SPN/MET 230/50 CON	
95T-0501-02	95T ITL/MET 230/50 CON	
95T-0601-02	95T DUT/MET 230/50 CON	
95T-0801-02	95T POR/MET 230/50 CON	
95T-1601-02	95T ENG/TUR 230/50 CON	
95T-0102-02	95T ENG+MET 240/50 UK	0017-00003-0890 LINE-CORD: U.K; R/A
95T-0109-02	95T ENG+MET 230/50 UK	
95T-0104-02	95T ENG+MET 240V+ AUS	0017-00003-0996 LINE-CORD: IEC; AUSTRALIAN; 230/50 C

OPTIONAL LINE CORDS		
0017-00003-0947	LINE-CORD: 120V; 20A;	12'
0017-00003-0915	LINE-CORD: R/A 120V	8'
0017-00003-0980	LINE-CORD: R/A; NEMA 5-20 144"	12'
0017-00003-0981	LINE-CORD: R/A; W/PLUG 220/60	7.5'
0017-00003-0948	LINE-CORD: 220V; 15A;	12'

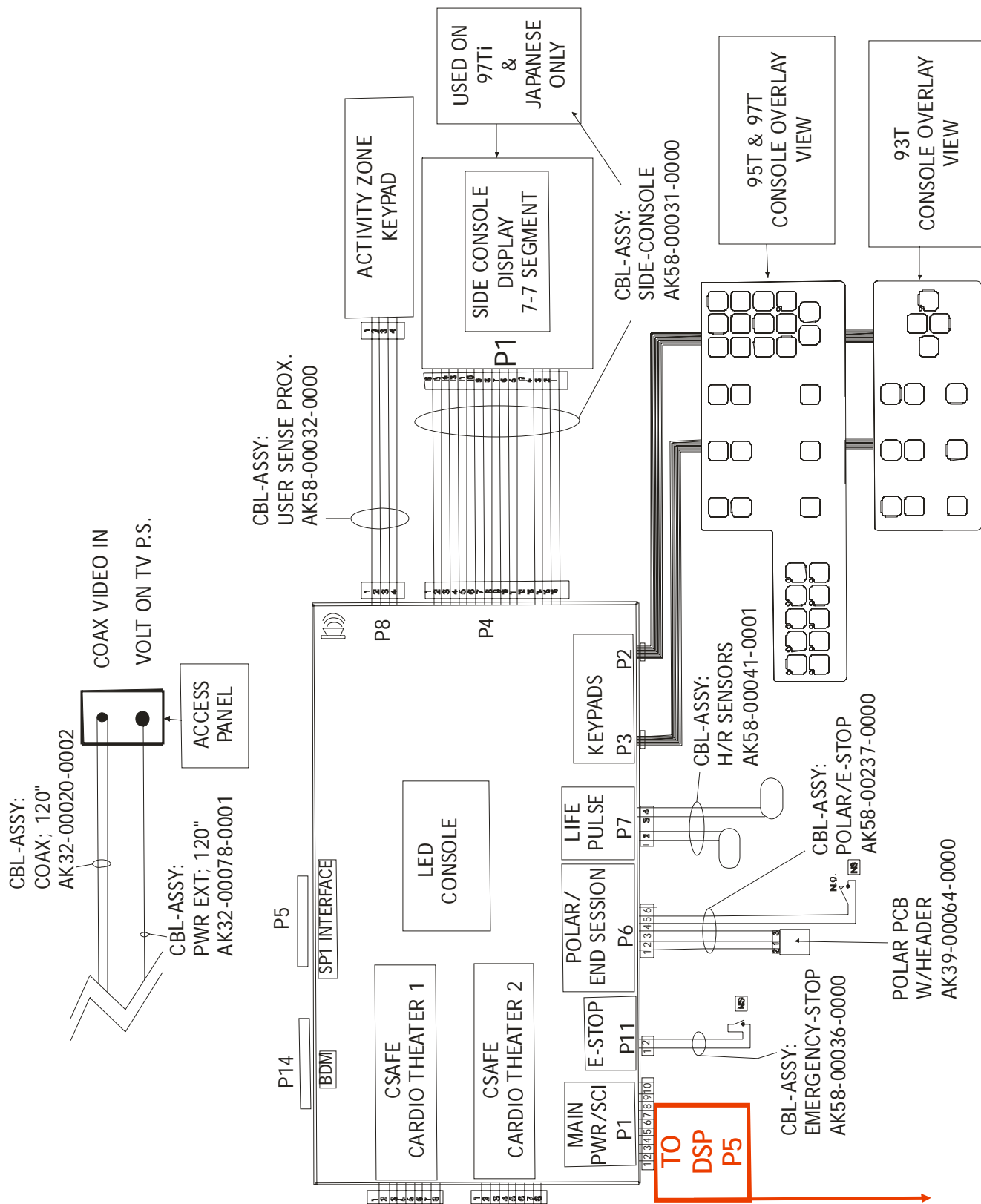

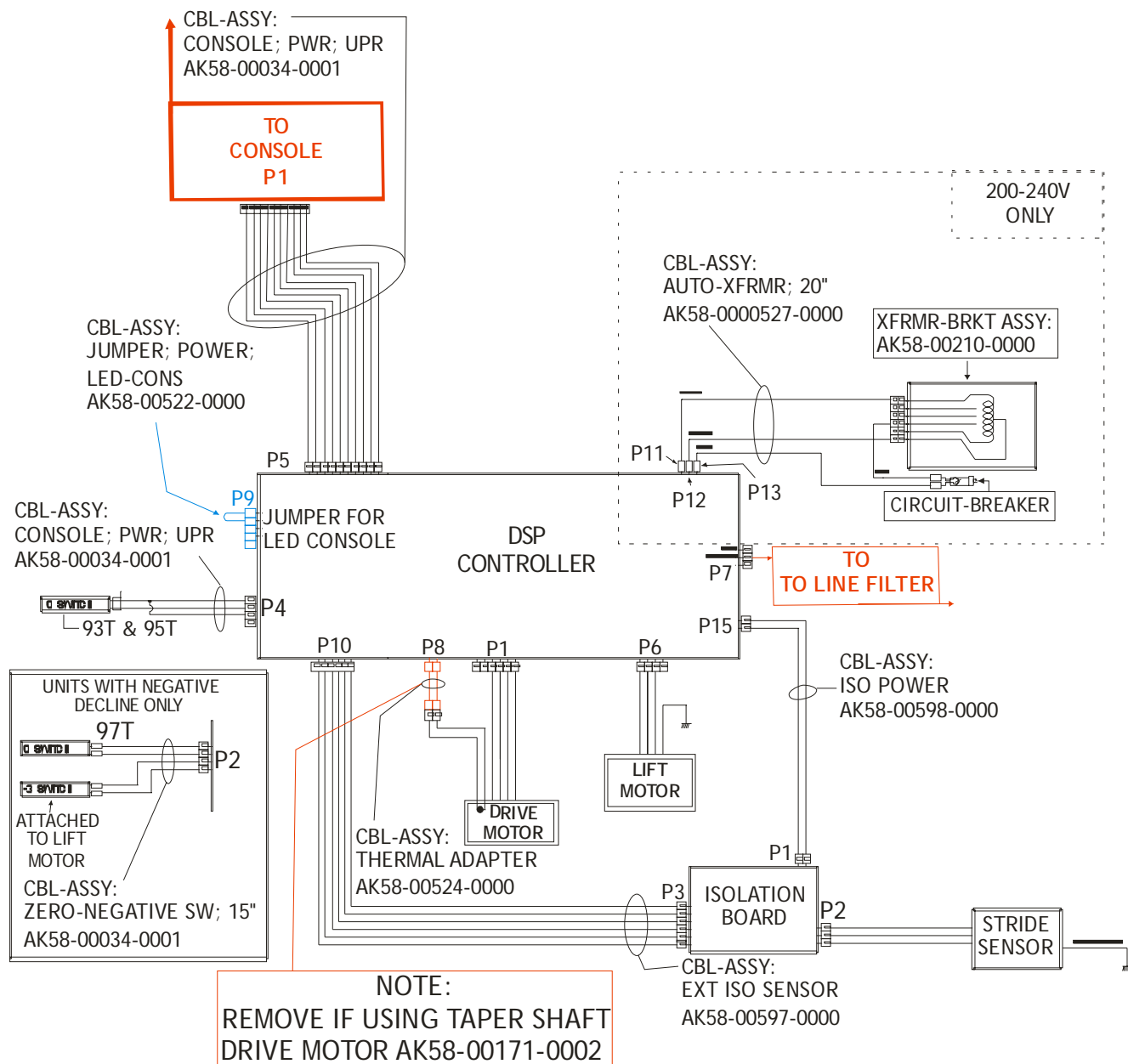

120V DOMESTIC

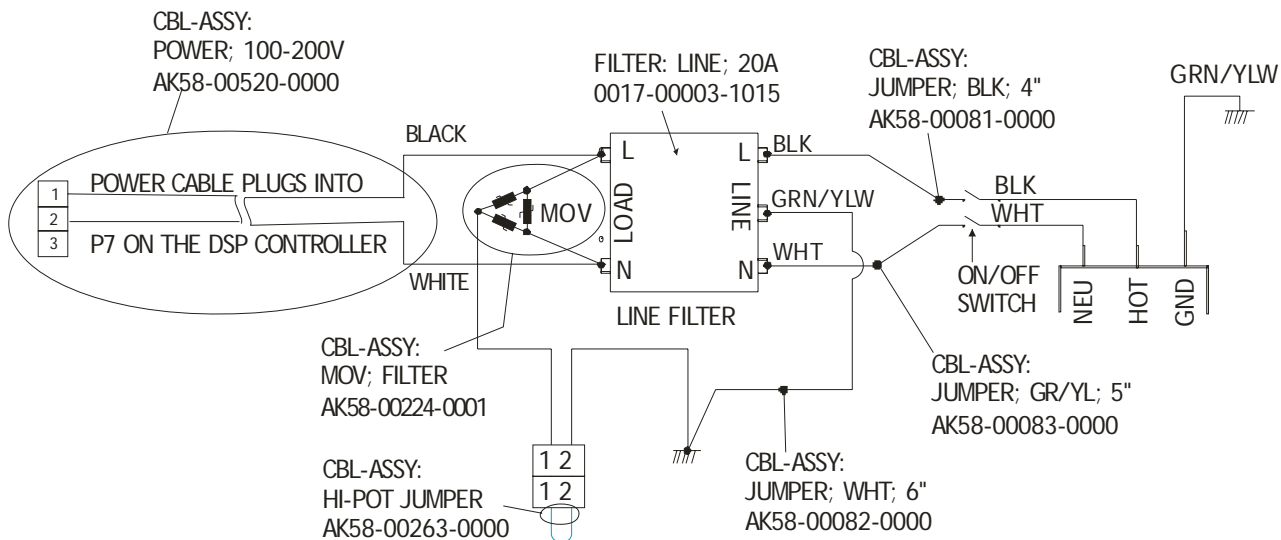

200-240V ONLY

