

Lifestride[®] 5500

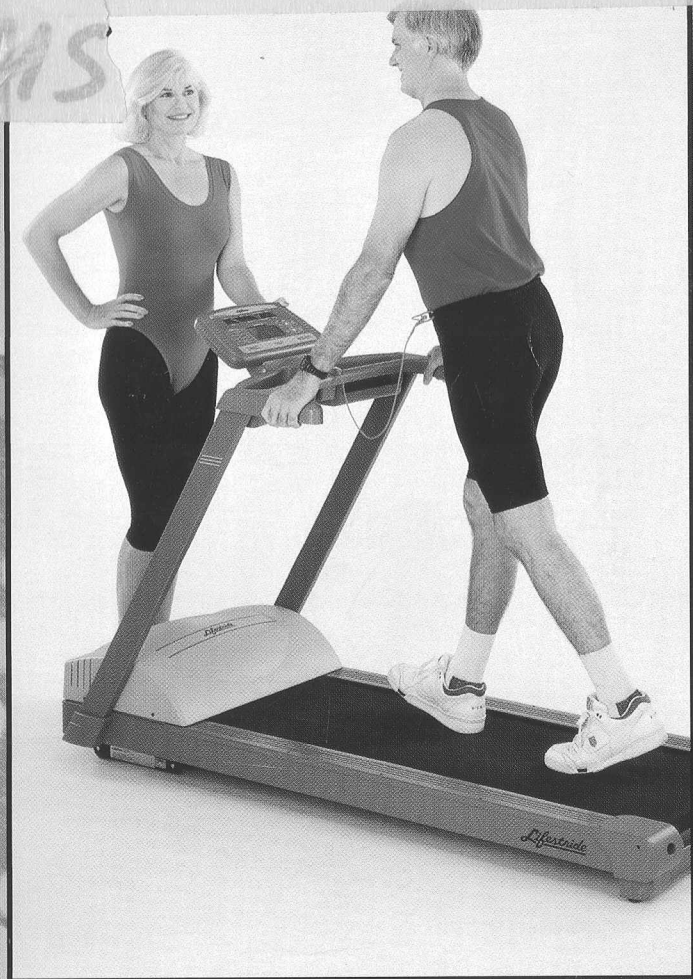

LifeFitness

10601 West Belmont Avenue
Franklin Park, Illinois 60131

M051-00K36-A006

LifeFitness

FITNESS GUIDE &

OPERATION MANUAL

Introduction

Congratulations... and welcome to the world of Life Fitness and the Lifestride[®] 5500 aerobic trainer. The Life Fitness reputation for quality exercise products that are motivating and reliable is unmatched in the fitness industry. The Lifestride treadmill is the fourth aerobic conditioning product from Life Fitness, joining the Lifecycle[®] aerobic trainer, the Liferower[®] total body conditioner and the Lifestep[®] aerobic trainer, all home and health club favorites.

Who uses the Lifestride aerobic trainer? People who value time and who need to make every minute count. Olympic athletes, movie stars, busy executives, top government administrators, sports celebrities and others all make the Lifestride trainer their exercise choice. Whether at home or at the office, using the Lifestride trainer is an excellent way to lose weight and improve your cardiorespiratory condition; and it's fun!

Why use a Lifestride trainer? Aerobic training with a Lifestride trainer is more than just a motivating experience. Regular aerobic exercise improves energy and endurance, reduces body fat, lowers the probability of heart disease, and tends to prolong life.* Consistent workouts can also diffuse the effects of everyday stress. Competitive athletes train aerobically to increase their heart strength, lung capacity and muscular endurance.

Read this manual now. Before using the Lifestride trainer, it is essential that you read this entire manual.

If you have further questions regarding the operation of the Lifestride trainer, please call Life Fitness Customer Service & Support at (708) 451-0036 or toll-free within the U.S. and Canada at (800) 351-3737. In Europe, call 49/89/310/6078 or your nearest fitness equipment dealer.

FCC Warning - Possible Radio/Television Interference

Note: This equipment has been tested and found to comply with the limits for a Class B digital device, pursuant to part 15 of the FCC rules. These limits are designed to provide reasonable protection against harmful interference in a commercial environment. This equipment generates, uses, and can radiate radio frequency energy. If not installed and used in accordance with the instruction manual, this product may cause harmful interference to radio communications. There is no guarantee that the interference will not occur in a particular installation. If this equipment does cause harmful interference to radio or television reception, which can be determined by turning the equipment off and on, you are encouraged to try to correct the interference by one or more of the following measures:

- Reorient or relocate the receiving antenna.
- Increase the space between the equipment and the receiver.
- Connect the equipment to an outlet on a different circuit than that to which the receiver is connected.
- Consult an exercise equipment dealer or an experienced radio/TV technician for help.

You are cautioned that any changes or modifications to this equipment could void your product warranty.

CAUTION: Anyone starting a vigorous exercise regimen should see a physician for a medical exam. We strongly recommend that you see your doctor before beginning any exercise program, especially if you have a history of high blood pressure, heart problems, or if you are over the age of 45.

LifeFitness

Sales and Product Information

Life Fitness
 Corporate Headquarters
 10601 West Belmont Avenue
 Franklin Park, Illinois 60131 U.S.A.
 (800) 735-3867 Toll-free (within the U.S. and Canada)
 (708) 451-0036
 Fax: (708) 288-3703

Customer Service, Assistance on Installation, Operation, Warranty, Parts and Repairs:

Life Fitness
 Customer Service & Support
 10601 West Belmont Avenue
 Franklin Park, Illinois 60131 U.S.A.
 (800) 351-3737 Toll-free (within the U.S. and Canada)
 (708) 451-0036
 Fax: (708) 288-3702

Europe:

Life Fitness Europe GmbH
 Siemenstrasse 3
 85716 Unterschleissheim
 Munich, Germany
 Telefon: 49/89/3106078
 Fax: 49/89/3107369
 Telex: 5215918 LSG

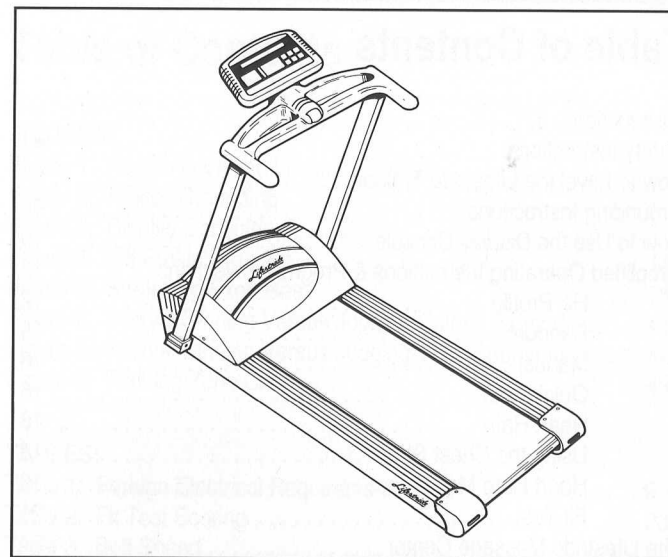

The Lifestride 5500 trainer, designed exclusively for home use, provides you with an effective workout that is both motivating and time-efficient. The user-friendly console provides a host of visual feedback, acting as a coach and trainer with easy-to-follow instructions and helpful message displays throughout the workout.

It's Intelligent: Choose from the five standard Life Fitness workout programs, or the new Heart Rate program. This optional heart rate training system provides you the most accurate heart rate readings available and maintains your heart rate by automatically varying incline in response to your current heart rate. By exercising at a level within your Training Heart Rate Range, you will gain the full benefits of aerobic exercise.

In the past, people with special health conditions have been advised by medical specialists to maintain a specified level of watts or calories per hour during their workouts as an indirect means of regulating their heart rate. With the Lifestride trainer, these types of exercise prescriptions are unnecessary, since you can directly monitor your heart rate regardless of the program you use. Also, with the Heart Rate program, you can work out at a prescribed heart rate profile automatically.

It's Motivating: An easy-to-read, message display provides motivating feedback of your workout so you'll always know how you're doing. Your heart rate, elapsed time, calories burned per hour, total calories burned, actual walking or running speed, distance traveled, and terrain are continually displayed.

It's Easy: The user-friendly, modern computer console guides you through every step of your program.

Table of Contents

Introduction	1
Safety Instructions	6
How to Level the Lifestride Trainer	8
Grounding Instructions	9
How to Use the Display Console	10
Simplified Operating Instructions & Program Selections	12
Hill Profile	12
Random	15
Manual	16
Quick Start	16
Heart Rate	18
Using the Chest Strap	18
Heart Rate Monitor	19
Fit Test	21
The Lifestride Message Center	24
Belt Speed and Grade Incline	27
Preventative Maintenance Tips	29
How to Adjust and Tension the Striding Belt	30
How to Obtain Product Service	32
Lifestride 5500 Specifications	33
APPENDIX:	
Proper Stretching Techniques	35
Tips for Good Stretching Results	38
Do's and Don'ts	39
How to Choose an Aerobic Training Method	40
Interval Striding Compared to Running	41
Interval Striding: The Exercise for the 90s	42
Determining an Interval Striding Program Level	43
About the Interval Striding Programs	43
Lifestride Interval Striding Programs	44
Interval Striding Using the Manual and Random Programs	46
How to Exercise Effectively	47
Calculating a Training Heart Rate Range	47
Checking Your Pulse	48
How to Stay Motivated	50
How to Develop a Personal Exercise Plan	52
Planning An Aerobic Workout	52
Fit Guidelines	53

Table of Contents

FIGURES:

Figure 1: How to Level the Lifestride Trainer	8
Figure 2: Proper Grounding	9
Figure 3: Display Console	10
Figure 4: Hill Profile Program	14
Figure 5: Stretching Exercises	36
Figure 6: Interval Striding Versus Jogging-Caloric Expenditure	41
Figure 7: Interval Striding Versus Jogging-Time Requirement	42
Figure 8: Training Zone Chart	49

TABLES:

Table 1: Foreign Electrical Requirements	9
Table 2: Fit Test Scoring	23
Table 3: Belt Speed	27
Table 4: Treadmill Hill Profile	28
Table 5: Training Heart Rate Range	55
Table 6: Weight Conversion	57
Training Log	58

Safety Instructions

It is essential that you read this entire manual. It explains the design philosophy of the Lifestride trainer, how to operate it, and ways to tailor your aerobic workouts to meet your personal fitness objectives.

Danger: To reduce the risk of electrical shock, always unplug the Lifestride unit from the electrical outlet before cleaning or attempting any maintenance activity.

Safety First:

Always clip the "SAFETY KEY CORD" to your waistband to immediately shut off the treadmill in case of an emergency dismount.

1. The Lifestride trainer should be left on, except when initiating any maintenance or service activities, then unplug the unit.
2. The equipment is to be used only by adults. Close supervision is needed and appropriate measures should be taken to prevent spectators or pets from interfering in any way while an exercise routine is in progress.
3. Always follow the console instructions for proper operation.
4. Never operate a Lifestride unit if it has a damaged power cord or electrical plug, or if it has been dropped, damaged, or immersed in water, even partially. Contact Life Fitness Customer Service & Support for examination and repairs.
5. Keep the power cord away from heated surfaces.
6. Do not pull the Lifestride unit by the power cord or use the cord as a handle.
7. Never operate a Lifestride unit with the air openings on the front motor housing blocked. Keep air openings free of lint, hair or any obstructing material.
8. Never drop or insert any object into any opening in a Lifestride unit.
9. Never place liquids in spillable containers of any type directly on the unit.
10. Do not use the Lifestride trainer outdoors.
11. Do not use the unit in areas where aerosol spray products are being used or where oxygen is being administered. Such substances increase the danger of combustion and explosion.
12. To disconnect: Remove the plug from the electrical outlet by gripping the plug firmly and pulling it out of the outlet. Do not remove the plug from the electrical outlet by pulling on the cord.
13. Keep all loose clothing and towels away from the treadmill's running surface and belt rollers.
14. **WARNING:** Keep the area six feet behind the treadmill clear of any obstructions. Keep the treadmill at least six feet from walls, furniture, or any obstructions.
15. Never mount or dismount the treadmill while the running belt is moving. Use the handlebar whenever additional stability is required.
16. Wear proper shoes such as those with rubber or high-traction soles. Do not use shoes with heels, leather soles, cleats or spikes. Make sure no stones are embedded into the soles. Do not use the treadmill with bare feet.
17. Never walk or jog backwards on the belt.
18. Do not reach underneath the unit or tip it on its side during operation.
19. If you have any questions, contact Life Fitness Customer Service & Support at (708) 451-0036 or toll-free at (800) 351-3737 (within the U.S. and Canada) In Europe, call: 49/89/3106078 or your nearest fitness equipment dealer.

SAVE THESE INSTRUCTIONS FOR FUTURE REFERENCE.

How to Level the Lifestride Trainer

The Lifestride 5500 must be leveled where it will be operated.

IT IS EXTREMELY IMPORTANT THAT THE TREADMILL BE CORRECTLY LEVELED FOR PROPER OPERATION. AN UNSTABLE UNIT MAY CAUSE STRIDING BELT MISALIGNMENT.

The treadmill striding belt is properly centered at the factory; however, the leveling legs may need to be readjusted at the location in which the unit is placed.

Figure 1: How to Level the Lifestride Trainer

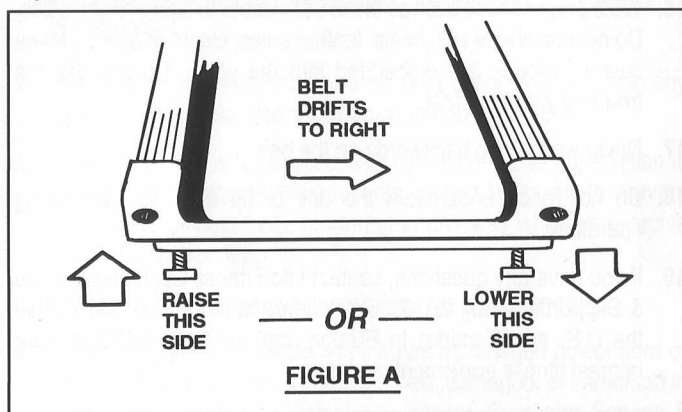

After placing the treadmill in its intended location for use, begin a program, but DO NOT begin running. It is important to insure that the striding belt remains centered during operation. If the belt drifts to the right, see Figure A. If the belt drifts to the left, see Figure B.

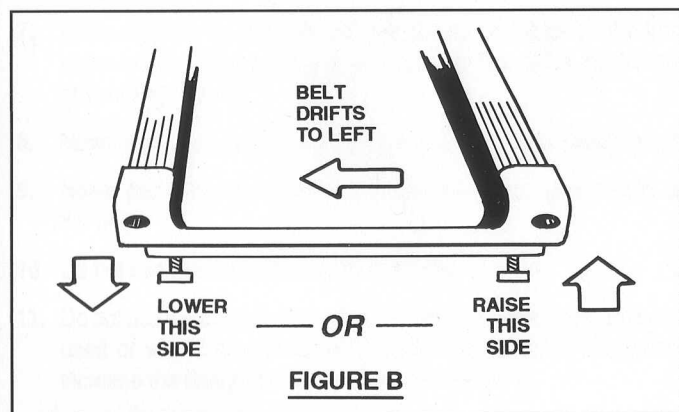

Grounding Instructions

For safe operation, the Lifestride trainer must be properly grounded. If the unit malfunctions or breaks down, proper grounding provides a path of least resistance for an electrical current, which reduces the risk of electrical shock to someone touching or using the unit. Each unit is equipped with an electrical cord which includes an equipment grounding conductor and a grounding plug. The plug must be plugged into an appropriate outlet that is properly installed and grounded in accordance with all local codes and ordinances.

Figure 2: Proper Grounding

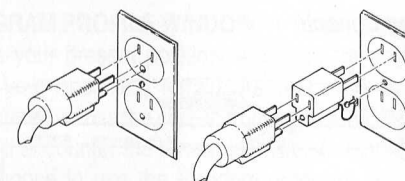

A temporary adapter, similar to the adapter above, may be used to connect this plug to a 2-pole receptacle if a properly grounded outlet is not available (U.S. and Canada). THE TEMPORARY ADAPTER SHOULD BE USED ONLY UNTIL A PROPERLY GROUNDED OUTLET CAN BE INSTALLED BY A QUALIFIED ELECTRICIAN.

DANGER: A risk of electrical shock may result from improper connection of the equipment-grounding conductor. Check with a qualified electrician if you are in doubt as to proper grounding techniques. Do not modify the plug provided with the product. If it does not fit your electrical outlet, have a proper outlet installed by a qualified electrician.

Table 1: Electrical Requirements

LOCATION	VOLTAGE	Hz	AMP
U.S., Canada, Equador, Costa Rica, Guatemala, Italy, Mexico & Venezuela	120	60	1
United Kingdom	240	50	1
France, Germany, Korea & Spain	220	50	1
Chili, Argentina	220	50	1
Brazil, Columbia	115/220	60	1
Australia	240	50	1
Japan	100	50 or 60	2
New Zealand	230	50	1

How to Use the Display Console

The computerized display console allows you to watch your progress as you walk, jog or run.

The on-board computer lets you tailor your workout to your individual fitness capabilities and provides a unique means of measuring your fitness improvement from one workout to the next. You'll want to challenge yourself by gradually increasing exercise intensity and exercise time as your endurance improves.

The display console is simple to program and easy to use.

Figure 3: Display Console

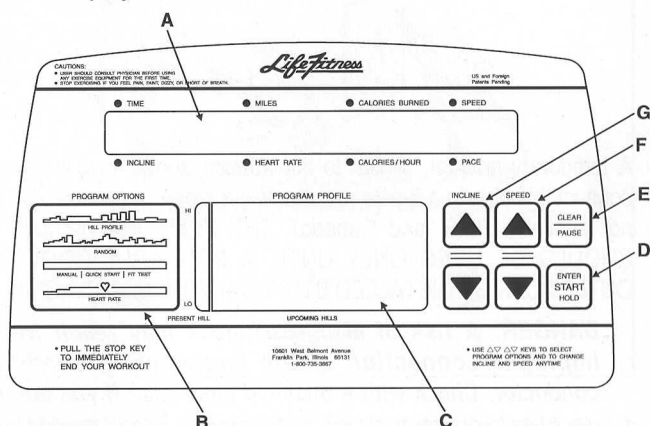

A. INSTRUCTIONS (MESSAGE CENTER): Provides simple step-by-step instructions.

TOP ROW

- TIME:** Provides an elapsed time of your workout and as a stopwatch enabling you to check your pulse at the end of your Fit Test or during the Pause mode.
- MILES:** Displays distance (miles) traveled. At the end of your workout, the total distance traveled will be displayed.
- CALORIES BURNED:** Displays total calories burned.
- SPEED:** Displays the current belt speed in miles per hour.

BOTTOM ROW

- INCLINE:** Displays the current treadmill elevation.

- HEART RATE:** When used in conjunction with the optional Heart Rate program, your current heart rate will be displayed.
- CALORIES / HOUR:** Displays calories burned per hour.
- PACE:** Displays your selected speed in minutes per mile.

The Message Center scrolls between the top and bottom row every 10 seconds. Toggle between a constant display of the top or bottom row by pressing the ENTER-START-HOLD key.

- B. PROGRAM OPTIONS:** These diagrams depict the various profiles as well as hills and valleys encountered within the six Lifefitness programs.
- C. PROGRAM PROFILE WINDOW:** A "flashing" matrix of LED lights shows your present position, while the "steady" matrix of lights show your upcoming terrain. As your workout progresses, the lights move across the screen from right to left. With the Hill Profile, you will encounter the terrain identified in Figure 4 on page 14. If you choose to use the Random program, you will encounter a series of random hills and valleys with over one million variations, so you will never experience the same workout twice. If you choose the Manual, Quick Start, or Fit Test program, you will walk or jog at a steady pace with no hills and valleys appearing in the LED matrix window. If you choose the optional Heart Rate program, you will begin at a lower speed and incline, progressing to a constant rate.
- D. ENTER START HOLD:** This key is used to begin an exercise program, to restart a program after pausing or to enter the data displayed in the message center.
- E. CLEAR-PAUSE:** Press this key once to put an exercise program on hold for up to five minutes. The striding belt stops while the program is on hold. The stopwatch can be used to time your rest period or to time the pulse check procedure. You can resume your exercise program by pressing the ENTER key. The CLEAR-PAUSE key may also be used to clear any entry. Pressing this key two successive times during the data entry stage will reset the programs.
- F. SPEED ▲ ▼:** Pressing the ▲ or ▼ keys allow you to increase or decrease the belt speed from 0.5 m.p.h. to 11.0 m.p.h. You may change the belt speed at any time during a program.
- G. INCLINE ▲ ▼:** Pressing the ▲ or ▼ keys allows you to increase or decrease the elevation of the Lifefitness deck from 0% to 15%. You may change the incline at any time during a program.

Simplified Operating Instructions & Program Selections

Selecting a Lifestride workout program is easy. Six computerized aerobic workout programs are available on your Lifestride trainer:

1. Hill Profile
2. Random
3. Manual
4. Quick Start
5. Heart Rate
6. Fit Test

- To begin, press the START key.
- The message center will ask your weight; enter your current weight using the ▲ ▼ keys, then press the ENTER key.
- The message center will ask you to select a program using the ▲ ▼ keys. Pressing the ▲ ▼ keys will prompt through the six exercise programs: HILL PROFILE, RANDOM, MANUAL, QUICK START, HEART RATE, or FIT TEST. Press the ENTER key to select a program:

HILL PROFILE - progressively increasing incline levels mixed with periods of less elevation.

RANDOM - different incline levels which vary randomly with each exercise session.

MANUAL - constant incline and belt speed without variation.

QUICK START- 60-minute MANUAL program during which you can increase the speed and incline.

HEART RATE - automatically maintains your target heart rate by altering the incline at a given speed.

FIT TEST - measures your aerobic fitness level in comparison to others of the same sex and age.

Hill Profile

- Upon selecting a Hill Profile workout, you will be requested to enter your desired workout time. Enter either 1 through 6, 9, 12, 15, 18,

24, 36, 48, or 60 minutes using the ▲ ▼ keys, then press the ENTER key.

- After selecting a workout duration, you will be requested to select an incline level. Select an incline level from 1 to 12 using the ▲ ▼ keys then press ENTER. You will then be requested to select a belt speed from 0.5 to 11.0 m.p.h. using the ▲ ▼ keys.

(CAUTION: The belt will begin traveling at 0.5 m.p.h. while you are selecting your speed.)

- After you've selected a belt speed, press the ENTER key.

NOTE: You may change the level of intensity at any time during an exercise program by pressing the ▲ ▼ keys.

The Lifestride trainer's patented Hill Profile program offers the ideal configuration for interval training: periods of high-effort aerobic activity separated by regular intervals of low-intensity exercise. The Hill Profile program is available in various time durations. You can select 1 through 6, 9, 12, 15, 18, 24, 36, 48, or 60 minute programs. Each program is composed of four stages: (1) Warm-up, (2) Plateau, (3) Interval Training, and (4) Cool Down.

The Lifestride treadmill is unique in the fitness industry. Its patented, computerized interval training program has been scientifically demonstrated to yield more statistically significant cardiorespiratory improvement than steady-pace training. The Hill Profile program offers interval training with progressive overload. Not only does it offer the challenge of alternating periods of high and low intensity, but the levels of intensity become progressively more difficult during the course of the program.

Warm-up Period: Gradually brings your heart rate into the lower portion of your Target Heart Rate Range and increases respiration. Blood flow to working muscles also increases (see page 47 to calculate your THRR).

Plateau Period: Increases heart rate so that it is within your THRR. Take your pulse (heart rate check) at the end of the plateau period to ensure that you have entered your THRR.

Interval Training Period: Comprises periods of higher and lower intensity levels. During this period, you are confronted with four progressively higher incline levels. Each is separated from the next by a recovery period. Take your pulse at the end of the interval training period to ensure that you have stayed within your THRR.

Cool-down Period: Reduced incline levels gradually reduce heart rate to the lower end of your THRR. The cool-down period allows the body to begin removing accumulated end-products of exercise, such as lactic

acid, which tend to build up in muscles during a workout and contribute to muscle soreness.

Heart Rate Check Points: Check your heart rate near the end of the plateau period and at the end of the interval training period. You might want to press the PAUSE key and then check your heart rate. The treadmill will pause for up to five minutes. You should always take your pulse at the times indicated to make sure you are staying within your personal THRR.

The Hill Profile program below shows the effort level and recovery periods encountered during a Lifestride workout. Effort and recovery periods are simulated on the display console by columns of red and yellow lights in the Program Profile window. The columns move from right to left during the workout. The higher the column, the higher the incline. Consequently, you must increase your effort.

Figure 4: Hill Profile

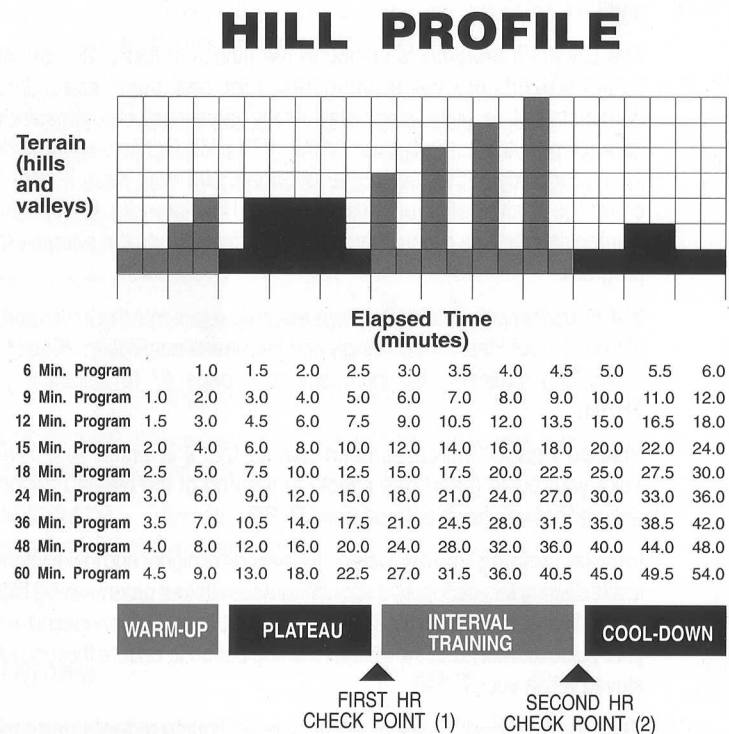

FOR FAT LOSS TRAINING:

(1) FIRST HEART RATE CHECK POINT: At the first heart rate check point, your pulse should be between 60% and 70% of the theoretical maximum heart rate for your age category for fat loss training.

(2) SECOND HEART RATE CHECK POINT: At the second heart rate check point, your pulse should be between 70% and 75% of the theoretical maximum for your age category for fat loss training.

FOR CARDIORESPIRATORY TRAINING:

(1) FIRST HEART RATE CHECK POINT: At the first heart rate check point, your pulse should be between 75% and 80% of the theoretical maximum (see Training Zone chart on page 49) for your age category for cardiorespiratory training.

(2) SECOND HEART RATE CHECK POINT: At the second heart rate check point, your pulse should be between 80% and 85% of the theoretical maximum heart rate for your age category for cardiorespiratory training.

Random or Manual

- Use the ▲ ▼ keys to select a goal: Time, Miles, or Calories. Press the ENTER key for your selection.
- Use the ▲ ▼ keys to enter a specific time, distance or calories goal as desired. A valid time goal is from 1 to 90 minutes, a valid distance goal is from 0.1 to 10.0 miles, and a valid calories goal is from 1 to 2000 calories.
- In the RANDOM program only, enter an incline level from 1 to 12 then press the ENTER key. (The MANUAL program does not require an incline level.)
- Use the ▲ ▼ keys to select a belt speed from 0.5 to 11.0 m.p.h. (CAUTION: the belt will begin traveling at 0.5 m.p.h. while you are selecting your speed.) Press the ENTER key.

NOTE: You may change the level of intensity at any time during an exercise program by pressing the ▲ ▼ keys.

— Random

In the Random program, the computer randomly selects hill-and-valley terrain which varies with every exercise program. Over one million combinations are offered in an interval training format. Because the incline levels are changing more often, it is more difficult than the Hill Profile program. As a result, it is recommended that the Random

program be set one or two levels lower than normally selected during the Hill Profile program.

Heart Rate Check Points: *Check your heart rate after the first five minutes of exercise on the Random program and every five to ten minutes thereafter. This ensures that you are exercising within your THRR.*

— Manual

This program provides steady-pace exercise with a fixed speed rate and incline level equal to that of the highest hill encountered on the Hill Profile program at the same level of intensity. Because of the greater effort levels of this program, it is recommended that you set the Manual program about three to four levels lower than the level of intensity that you would normally select on the Hill Profile Program.

Heart Rate Check Points: *Check your heart rate after the first five minutes of exercise on the Manual program and every five to ten minutes thereafter. This ensures that you are exercising within your THRR.*

You can also design your own interval training program using the Manual program by varying the level of intensity during the course of your workout. To do so, select a high level of intensity until you reach the upper end of your target heart rate range, then stride at a lower level of intensity until your heart rate drops to the bottom of your THRR. Then, increase the level of intensity until you reach your upper range heart rate again. By repeating this process, you will be simulating your own hills and valleys.

Changing the Level of Intensity (Difficulty)

In the Hill Profile, Random, and Manual programs, if your heart rate is above your THRR, you should reduce your level of intensity by pressing the ▲ ▼ keys. If your heart rate is below your THRR, you should enter a higher number to increase the level of intensity. You should not change your workout intensity if your heart rate is within your THRR.

Quick Start

- Begin the Quick Start Program for one minute at a speed of 1.5 m.p.h. Use the speed ▲ key to increase your speed from 0.5 to 1.5 m.p.h. The running belt will begin traveling slowly while you are selecting your desired speed.
- Begin walking at a pace of 1.5 m.p.h. to get the feel of the Lifestrider treadmill. Hold the handrails if necessary.

- Once you are comfortable, press the speed ▲ key to increase belt speed to 2 m.p.h. Release one hand from the handrail and let that arm swing with your body rhythm. Next, release the other hand and walk without holding the handrails.
- Look forward for spatial awareness; this will help maintain balance and ensure exercise comfort.
- Walk or jog in an upright position to avoid excessive leaning and back fatigue.
- Press the incline ▲ key to slowly incline the treadmill. To stop press clear twice.

If your concentration is broken, immediately pull on the safety key cord to stop the machine and then grab the handrails.

This program provides steady-pace exercise.

Heart Rate Check Points: *Check your heart rate after the first five minutes of exercise on the Quick Start program and every five to ten minutes thereafter. This ensures that you are exercising within your THRR.*

You can design your own interval training program using the Quick Start program by varying the level of intensity during the course of your workout. To do so, select a high level of intensity until you reach the upper end of your Target Heart Rate Range, then stride at a lower level of intensity until your heart rate drops to the bottom of your THRR. Then, increase the level of intensity until you reach your upper range heart rate again. By repeating this process, you will be simulating your own hills and valleys. This program does not require a goal of time, calories or distance.

Heart Rate (functional only if a heart rate strap is worn and detected)

The Life Fitness Heart Rate program, the most accurate Heart Rate monitoring system available on any treadmill, takes the guesswork out of working out. This revolutionary heart rate management system automatically adjusts your incline to keep you at your appropriate target heart rate while you exercise. Under-training and over-training are eliminated.

NOTE: The Heart Rate program will not activate without acknowledgment from the optional Heart Rate Management System, which includes a chest strap and receiver.

Using the Chest Strap

Wet the electrodes of the transmitter (the two grooved surfaces on the underside of the strap) and secure the strap as high under the chest muscles as possible. The strap should be snug, but comfortable enough to allow for normal breathing.

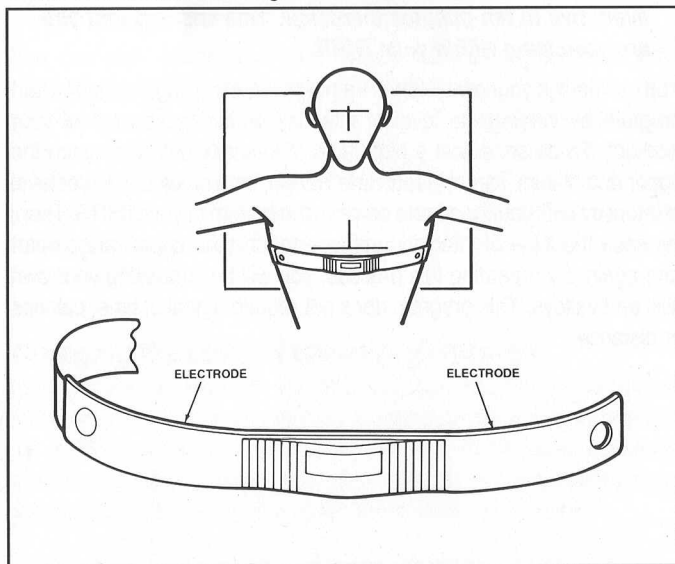

The transmitter strap will deliver an optimum heart rate reading when the electrodes are directly in contact with bare skin. Also, it will function properly through wet, lightweight clothing. The key to proper operation is for the electrodes to remain wet to conduct the electrical impulses of the heart back to the receiver.

If it becomes necessary to moisten the chest strap transmitter, just grasp the center of the transmitter and pull it away from the chest to expose the two electrodes and moisten them in this position.

Heart Rate Monitor Receiver Installation

A cover plate securing the wire harnesses in place is located on the underside of the handlebar. Beneath the cover plate and immediately behind the emergency stop switch is a 3-pin connector matching the one on the Heart Rate Receiver Unit. It may be necessary to remove the screw noted in the illustration and carefully bend the flexible cover plate to gain access to this connector. **DO NOT** remove the entire cover plate. Once located, snap the two connectors together.

You will notice four rectangular cutouts on the plate covering the emergency stop switch. These correspond to the four tabs on the housing of the Receiver Unit. Align the cutouts with the tabs and carefully snap the unit securely into place to complete the installation procedure.

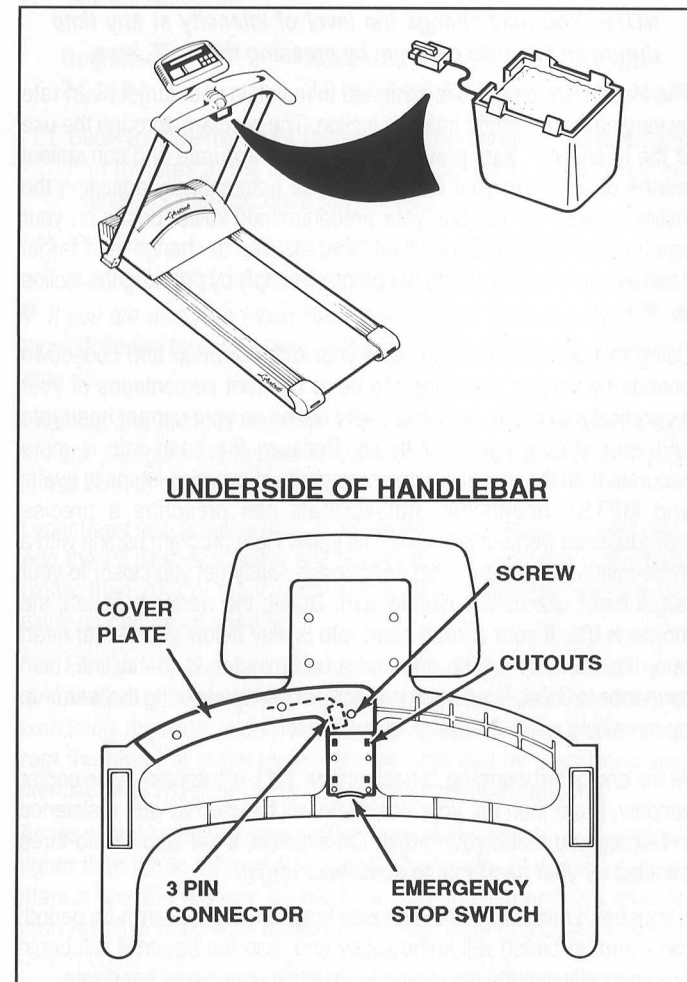

- Enter your age using the ▲ ▼ keys to receive a computed target heart rate. Your 70% target heart rate based on your age will appear. Press ENTER to accept, or use the ▲ ▼ keys to change your target heart rate.
- Use the ▲ ▼ keys to select a goal: Time, Miles or Calories. Press the ENTER key for your selection.
- Use the ▲ ▼ keys to enter a specific time, distance or calories goal as desired. A valid time goal is from 1 to 90 minutes, a valid distance goal is from 0.1 to 10.0 miles, and a valid calories goal is from 1 to 2000 calories.
- Use the ▲ ▼ keys to select a belt speed of from 0.5 to 11.0 m.p.h. (**CAUTION: The belt will begin traveling at 0.5 m.p.h. while you are selecting your speed.**) Press the ENTER key.

NOTE: You may change the level of intensity at any time during an exercise program by pressing the ▲ ▼ keys.

The Heart Rate program is designed to maintain your target heart rate by varying the Lifestride trainer's incline. The program, through the use of the heart rate strap, provides you with an accurate and convenient means of obtaining your heart rate while automatically adjusting the incline in order to maintain your predetermined value, based on your age and the Training Zone Chart. You are free to change your target heart rate at any time during the program simply by pressing the incline ▲ ▼ keys.

Using this option, you can create your own warm-up and cool-down periods by varying your target to be at different percentages of your theoretical maximum. Incline will vary based on your current heart rate and your striding speed or m.p.h. Because the heart rate is more accurate than the traditional measurements of exercise intensity (watts and METS), healthcare professionals can prescribe a precise individualized workout program. The Heart Rate program begins with a three-minute warm-up period designed to safely get you closer to your target heart rate from a resting start. During the warm-up period, the incline is 0%. If your current heart rate is way below your target heart rate, the warm-up will be one and a half minutes at 0% incline, then increases to 3.0%. Your heart rate will be displayed during the warm-up by remaining within the range of the sensor.

At the end of the warm-up, a heart shape (♥) will appear in the center window. From then on, your heart rate will be used to vary resistance in helping you reach your target. On average, it will take two to three minutes for your heart rate to reach your target.

If your heart rate is above the chosen target during the warm-up period, the warm-up period will immediately end, and the treadmill will begin automatically altering the incline to maintain your target heart rate.

Fit Test

The Lifestride FIT TEST program is another exclusive feature of this versatile aerobic product. Think of it as your "relative fitness score." Use the Fit Test to monitor improvement in your endurance every four to six weeks.

- After selecting FIT TEST and pressing the ENTER key, a flashing "Enter Your Age" appears in the Message Center. Use the ▲ ▼ keys to enter your age and then press ENTER.
- After entering your age, a flashing "Enter Your Sex" appears in the Message Center. Press ▲ for male or ▼ for female. This is necessary for accurate computation of your Fit Test score.
- After entering your sex, the Message Center will ask you to select your speed: 2, 3, 4 or 4.5 m.p.h. Use the ▲ ▼ keys to enter a desired speed. of:

Beginner	Advanced	Expert
2.0 m.p.h.	3.0 or 4.0 m.p.h.	4.5 m.p.h.

- Begin your five-minute Fit Test with a 60-second warm-up, followed by four minutes at 5% incline. The belt speed and incline will be maintained for an accurate computation.
- After you have completed the Fit Test, use the TIME prompt to take your 15-second pulse and use the ▲ ▼ keys to enter your pulse.

♥ *If you are using the Heart Rate System, your Fit Test score will be shown followed by your ranking in the Fit Test Scoring Table located on page 23.*

A number and rating of where you rank with others in your specific sex and age category will appear in the Message Center. Compare your fitness level to others by using Table 2 on page 23.

If your heart rate is below 65% of your theoretical maximum heart rate, redo the Fit Test at a faster belt speed. If your heart rate is too high (higher than 200) or too low (lower than 50), review the proper pulse taking procedure on page 48.

The Fit Test is also an estimate of your VO₂ max, which is a combination of how well the heart supplies oxygenated blood to the exercising muscles and how efficiently these muscles get oxygen from the blood. It is the measurement regarded by physicians and exercise physiologists as the standard for aerobic capacity.

Please note that the VO₂ max values received will be 10 to 15 percent higher than those achieved on a stationary cycle. Stationary cycling offers a specific workout for the quadricep muscle and this muscle often reaches maximum fatigue at a lower level of VO₂ max than a person could reach on a stairclimber or a treadmill.**

**Ebbeling, Cara B.; Puleo, Elaine M.; Ward, Ann; Widrick, Jeffrey, and Rippe, James M, "Development Of A Single Stage Submaximal Treadmill Walking Test". Univ. Of Ma. Medical Ctr., 1991 "Unpublished".

The rate of pedaling or stepping is often difficult to control. However, treadmill speed and incline can be regulated with precision. Also, unlike cycling or stepping, walking is a natural, habitual activity. Most people become accustomed to treadmill walking within one to two minutes.

Note: To receive a proper Fit Test score, you must be working within your Training Heart Rate Range (THRR) which is 65% of your theoretical maximum heart rate.

Fit Test Tips

The computer does not accept:

- heart rates less than 52 or greater than 200 beats per minute.
- body weights less than 25 pounds or greater than 275 pounds.
- ages below 10 years.
- data input that exceeds human potential.

If you make an error when entering any Fit Test information, you can correct it by pressing CLEAR and re-entering information requested on the Message Center.

Heart rate is dependent on many factors. It is important to take your Fit Test under similar circumstances each time:

- amount of sleep the previous night (seven or more hours is recommended).
- time of day.
- time you last ate (two to four hours after the last meal is recommended).
- time since you last drank a liquid containing caffeine or alcohol, or smoked a cigarette (four or more hours is recommended).
- time since you last exercised (at least six hours is recommended).

For the most accurate Fit Test results, you should perform the Fit Test on three consecutive days and average the three scores.

Table 2: Fit Test Scoring

Relative Fitness Classification For Men					
MEN	AGE				
RATING	20-29	30-39	40-49	50-59	60-69
Elite	61+	57+	55+	53+	50+
Excellent	55-60	52-56	50-54	47-52	44-49
Good	50-54	46-51	44-49	42-46	39-43
Above Average	44-49	41-45	39-43	36-41	33-38
Average	40-43	36-40	34-38	32-35	29-32
Below Average	34-39	31-35	29-33	26-31	23-28
Poor	29-33	25-30	22-28	20-25	18-22
Very Poor	<29	<25	<22	<20	<18

Relative Fitness Classification For Women					
WOMEN	AGE				
RATING	20-29	30-39	40-49	50-59	60-69
Elite	54+	51+	48+	46+	44+
Excellent	48-53	45-50	43-47	41-45	39-43
Good	43-47	40-44	37-42	35-40	33-38
Above Average	37-42	34-39	32-36	30-34	28-32
Average	33-36	30-33	28-31	25-29	23-27
Below Average	28-32	24-29	22-27	20-24	18-22
Poor	22-27	19-23	17-21	14-19	12-17
Very Poor	<22	<19	<17	<14	<12

Your Resting Heart Rate is Important

Another excellent indicator of cardiorespiratory health is your resting pulse. An average resting pulse is approximately 72 beats per minute. A lower pulse indicates a stronger, healthier heart. Monitoring your resting pulse is an easy way to measure the effectiveness of your exercise program. Take your pulse each day at the same time, preferably upon awakening and before you get out of bed. As your Personal Exercise Plan (PEP) continues, you'll notice a decrease in your resting heart rate. Be patient; this improvement takes at least eight to ten weeks of training.

Check Heart Rate While Exercising

You should check your heart rate periodically during each exercise session to ensure that you are working within your THRR. (See the Hill Profile diagram on page 14 for heart rate check points.) If you wish to check your heart rate, continue stepping and use the Time displayed to count 15 seconds.

The Lifestride Message Center

The Lifestride 5500 treadmill constantly monitors your performance during an exercise program, providing prompts to inform and advise you of your performance. The following script is what you might see during your workout.

MESSAGES

COMMENTS

Operation:

Hill Profile, Random, Manual, Quick Start, or Heart Rate Program

- | | |
|---------------------------------------------------------------|------------------------------------------------------------------------------------------------------------------------------------|
| <input type="checkbox"/> PRESS START TO BEGIN | Instructs you to begin an exercise program. |
| <input type="checkbox"/> ENTER WEIGHT
(USING ARROW KEYS) | You must enter your accurate weight. |
| <input type="checkbox"/> SELECT PROGRAM
(USING ARROW KEYS) | Prompts you to select an exercise program: Hill, Random, Manual, Quick Start, Fit Test or Heart Rate. |
| <input type="checkbox"/> MINUTES
(USING ARROW KEYS) | The Hill Profile program instructs you to select the duration of a workout: 1 through 6, 9, 12, 15, 18, 24, 36, 48, or 60 minutes. |
| <input type="checkbox"/> SELECT LEVEL
(USING ARROW KEYS) | Instructs you to select an incline level: 1 through 12 (1 is easiest, 12 the most challenging). |
| <input type="checkbox"/> SELECT GOAL
(USING ARROW KEYS) | Select workout duration of miles, minutes or calories. |

- | | |
|---------------------------------------------------------|-------------------------------------------------------------|
| <input type="checkbox"/> MILES | Prompts you to select desired miles to travel: 0.1 to 10.0. |
| <input type="checkbox"/> MAX IS 10 MILES | You have input an unavailable distance. |
| <input type="checkbox"/> MINUTES
(USING ARROW KEYS) | Prompts you to select desired minutes to work out (1-90). |
| <input type="checkbox"/> MAX IS 90 MINUTES | You have input an unavailable time. |
| <input type="checkbox"/> CALORIES
(USING ARROW KEYS) | Prompts you to select desired calories to burn up to 2000. |
| <input type="checkbox"/> MAX IS 2000 CAL | You have input an unavailable amount. |
| <input type="checkbox"/> TO BEGIN USE SPEED KEY | Speed is increased from 0.5 by pressing ▲ key. |
| <input type="checkbox"/> :00 PAUSED | You have pressed the PAUSE button (5-minute time limit.) |

Fit Test Operations

- | | |
|-----------------------------------------------------|------------------------------------------------------------------------|
| <input type="checkbox"/> AGE
(USING ARROW KEYS) | In the Fit Test program, you must enter your age: 10 through 99 years. |
| <input type="checkbox"/> SEX
(USING ARROW KEYS) | In the Fit Test program, you must indicate male or female. |
| <input type="checkbox"/> USE SPEED
KEYS TO BEGIN | Enter a belt speed of: 2.0, 3.0, 4.0 or 4.5 m.p.h. |
| <input type="checkbox"/> WARM-UP for 60
seconds | Start 1-minute warm-up for the Fit Test program. |

- BEGIN 5 MIN. FIT TEST NOW**

Start the 5-minute Fit Test.

- TAKE YOUR PULSE FOR 15 SECONDS, START AT THE BEEP**

Take your pulse for 15 seconds and then enter count.

- FIT TEST SCORE IS:**

Your relative Fit Test score is displayed. Compare your score with others of your sex and age in Table 2 on page 23.

Error Messages

Note: ANY condition other than those stated below are possible malfunctions. Please call service for further instructions. See page 36 for service numbers.

- OVER SPEED PROBLEM**

Belt speed exceeds the target speed. This may happen at high incline with low belt speed. simply lower your incline or increase your belt speed.

- START-UP PROBLEM**

The computer is not sensing any belt movement. This will occur if the belt is jammed or stalled.

- RUNNING PROBLEM**

After a program is started and running, the computer stopped detecting belt movement. Excessive weight on the belt will cause this message.

- BELT MOVING PROBLEM**

Belt is moving when not commanded. A loosely plugged in line cord, power glitch or turning the power on and off while the ble is moving will cause this.

- COMM TO M/C PROBLEM**

Cable problem, call service.

Belt Speed and Grade Incline

The chart below shows how you can design a workout based on belt speed and grade level. The lower the grade incline level at a set belt speed, the lower the caloric burn. The higher the grade incline level at a set belt speed, the greater the caloric burn. Design your workout by either a lower grade incline level at a greater speed, or a higher grade incline level at a lower belt speed.

The Lifestride aerobic trainer allows you to exercise in a manner that's both comfortable and advantageous. Those who enjoy a quicker pace at a lower grade level receive the same caloric expenditure advantages as those who would rather walk at a slower pace but at a higher grade incline. For example:

Table 3: Belt Speed *

Belt Speed	Grade Level (%)	Caloric Expenditure (Kcal/hr)
User 1 @ 7.0 m.p.h.	1	913
User 2 @ 4.0 m.p.h.	14	861
User 3 @ 1.5 m.p.h.	14	367
User 4 @ 3.5 m.p.h.	3	378
User 5 @ 5.0 m.p.h.	12	948
User 6 @ 6.5 m.p.h.	4	951

* Based on a 154 lb. user

Table 4: Treadmill Hill Profile - Incline % Grades

Incline Level	Hill Number						
	1	2	3	4	5	6	7
1	0	1.0	2.0	2.5	3.0	3.5	4.0
2	0	1.0	2.0	3.0	4.0	5.0	6.0
3	0	2.0	3.0	4.0	5.0	6.0	7.0
4	1.0	2.0	3.0	4.0	5.0	6.0	7.0
5	2.0	3.0	4.0	5.0	6.0	7.0	8.0
6	3.0	4.0	5.0	6.0	7.0	8.0	9.0
7	4.0	5.0	6.0	7.0	8.0	9.0	10.0
8	5.0	6.0	7.0	8.0	9.0	10.0	11.0
9	6.0	7.0	8.0	9.0	10.0	11.0	12.0
10	7.0	8.0	9.0	10.0	11.0	12.0	13.0
11	8.0	9.0	10.0	11.0	12.0	13.0	14.0
12	9.0	10.0	11.0	12.0 <td 13.0	14.0	15.0	

NUMBERS IN TABLE REPRESENT INCLINE GRADES IN PERCENTAGES.

Preventative Maintenance Tips

The Lifeslide aerobic trainer is backed by the engineering excellence of Life Fitness and is one of the most rugged and trouble-free pieces of exercise equipment on the market today. Life Fitness treadmills are one of the most popular trainers across the country, regularly standing up to marathon use — 18 hours a day, 7 days a week.

Here are some preventative maintenance tips that will keep your Lifeslide aerobic trainer operating at its best.

- Clean display console and all exterior surfaces regularly.
- Check operation of emergency stop once a week.
- Vacuum striding belt regularly to keep debris from accumulating.
- Inspect exterior parts regularly for wear and tear, especially the striding belt and deck.
- Inspect area under unit and vacuum regularly.

NOTE: When cleaning the exterior of the unit, a non-abrasive cleanser and soft cotton cloth are strongly recommended. At no time should cleanser be applied directly to any part of the equipment. Instead, place the non-abrasive cleaning solution on a soft cloth and wipe down the unit.

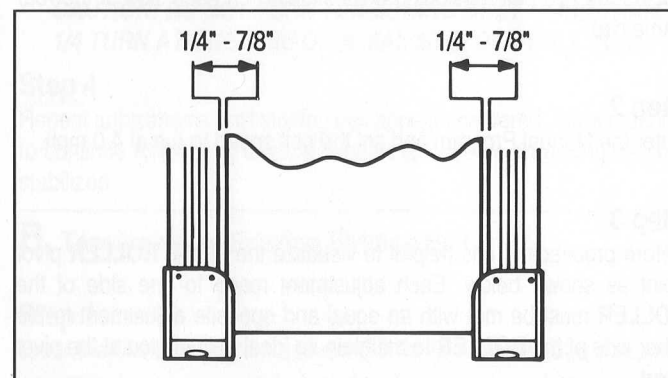

The optimum operating position of the striding belt is within 1/4" to 7/8" from either side of the frame. Should the striding belt travel beyond this dimension, check to be sure the treadmill is level prior to making any belt adjustments (see page 8). If leveling the unit fails to keep the striding belt centered, follow the instructions on the following pages for proper alignment, or contact Life Fitness Customer Support.

CAUTION: DO NOT MOVE UNIT OR PLACE YOUR HANDS UNDER UNIT WHILE IT IS PLUGGED INTO AN ELECTRICAL OUTLET.

How to Adjust and Tension the Striding Belt

Tool Required: 1/4" Hex key wrench

These instructions are to be followed when:

A. Centering an existing or new striding belt.

B. Tensioning an existing striding belt.

IT IS EXTREMELY IMPORTANT THAT THE TREADMILL BE CORRECTLY LEVELED PRIOR TO ANY TRACKING ADJUSTMENTS. AN UNSTABLE UNIT MAY CAUSE STRIDING BELT MISALIGNMENT. SEE THE LEVELING INSTRUCTIONS ON PAGE 8 PRIOR TO ATTEMPTING ANY REAR ROLLER ADJUSTMENTS.

A. Tracking (Centering) an Existing or New Striding Belt

Step 1

Locate the two belt tensioning bolts situated on each side of the rear frame cap.

Step 2

Enter the Manual Program and set the belt speed to run at 4.0 mph.

Step 3

Before proceeding, it is helpful to visualize the **REAR ROLLER** pivot point as shown below. Each adjustment made to one side of the **ROLLER** must be met with an equal and opposite adjustment to the other side of the **ROLLER** to maintain an ideal belt tension at the pivot point.

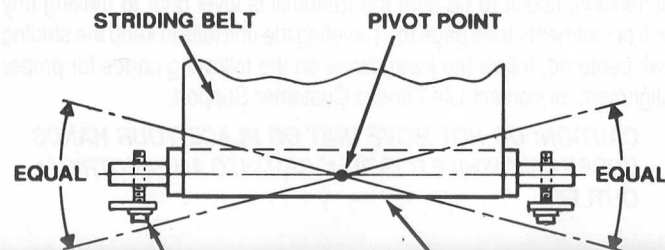

CAUTION: DO NOT OVERTIGHTEN THE TENSIONING BOLTS WHILE MAKING BELT ADJUSTMENTS. OVERTIGHTENING OF BOLTS MAY OVER STRETCH AND DAMAGE STRIDING BELT AS WELL AS PLACE AN UNNECESSARY LOAD ON THE ROLLER BEARINGS.

If the striding belt has moved to the right, turn the right tension bolt 1/4 turn clockwise and then turn the left tension bolt 1/4 turn counter-clockwise to start striding belt tracking back to center of roller.

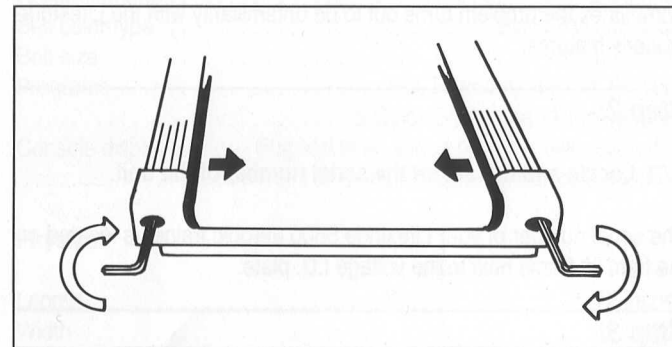

If the striding belt has moved to the left, turn the left tension bolt 1/4 turn clockwise and then turn the right tension bolt 1/4 turn counter clockwise to start striding belt tracking back to center of roller

CAUTION: DO NOT TURN TENSIONING BOLT MORE THAN 1/4 TURN AT ONE TIME OR A MAXIMUM OF 1 FULL TURN.

Step 4

Repeat adjustments until striding belt appears centered. Allow machine to continue running for several minutes to observe if tracking remains stabilized.

B. Tensioning an Existing Striding Belt

Step 1

Enter the Manual Program and run unit for five minutes at 5.0 m.p.h.

Step 2

With the belt speed at 2.0 m.p.h., tightly grasp the handrails and attempt to stall the striding belt. If striding belt slips, continue to Step 3.

Step 3

Stop the treadmill and alternately turn the belt tensioning bolts 1/4 turn clockwise to tension, not to exceed one full turn. Repeat Steps 1 and 2 until belt no longer slips. See Section A for belt centering procedures.

How to Obtain Product Service

If you have a problem . . .

Step 1:

- If possible, verify the symptom.

Sometimes the problem turns out to be unfamiliarity with the Lifestride trainer's features.

Step 2:

- Locate and document the serial number of the unit.

The serial number of your Lifestride 5500 aerobic trainer is located on the front lift frame next to the voltage I.D. plate.

Step 3:

- Contact Life Fitness Customer Service & Support.

Life Fitness Customer Support
10601 W. Belmont Avenue
Franklin Park, IL 60131 U.S.A.
(800) 351-3737 (toll-free within the U.S. and Canada)
(708) 451-0036
Fax: (708) 288-3702

In Europe:

Life Fitness Europe GmbH
Siemenstrasse 3
85716 Unterschleissheim
Munich, Germany
Telefon: 49/89/3106078
Telex: 5215918 LSG
Fax: 089/3107369

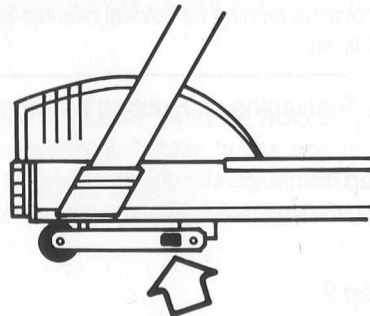

Please have the serial number of the product and the symptom ready for the Customer Support specialist who will be assisting you. This information is necessary for us to help solve any problems you may be encountering.

Lifestride 5500 Specifications

Designed use	Home
Speed range	0.5 - 11.0 m.p.h. in 0.1 increments
Elevation range	0 - 15% grade in 0.5% increments
Motor type	DC
Motor size	2.0 hp
Power requirements	120 volt, 15 amp
Roller diameter	2.0 inches
Belt color/type	Black PVC multi-ply
Belt size	52" L x 18" W
Programs	Hill, Random, Manual, Fit Test, & Quick Start (Heart Rate optional)
Console displays	Elapsed time, speed (m.p.h.), calories, miles, & % incline, pace, (heart rate optional)

Physical:

Length	72 inches
Width	29 inches
Height	46 inches
Weight	200 lbs.
Color	Dark & light gray with black & red accents

Shipping dimensions:

Length	75 inches
Width	31 inches
Height	18 inches
Weight	250 lbs.

APPENDIX

Proper Stretching Techniques

Stretching is perhaps the most neglected element of physical conditioning, because people do not associate flexibility with the more glamorous results of exercise — speed, strength and a lean body appearance. However, without significant flexibility, real gains in fitness are unnecessarily difficult to achieve and maintain.

Flexibility as a Fitness Safety Factor

Limber joints, muscles, and connective tissues provide the freedom of motion that makes exercise easier and more enjoyable to perform, and lessens the risk of injury. Without proper, consistent stretching, ligaments and tendons can become taut and shortened due to decreased circulation. These

inflexible tissues are more prone to chronic soreness and to rupture than loose, stretch-conditioned tissues. And, nothing is more discouraging than nagging injuries. Stretching helps people of all ages and fitness levels prepare themselves for the exertion required to participate in a program of regular muscular and aerobic training.

See pages 36 and 37 for illustrations of recommended stretching exercises.

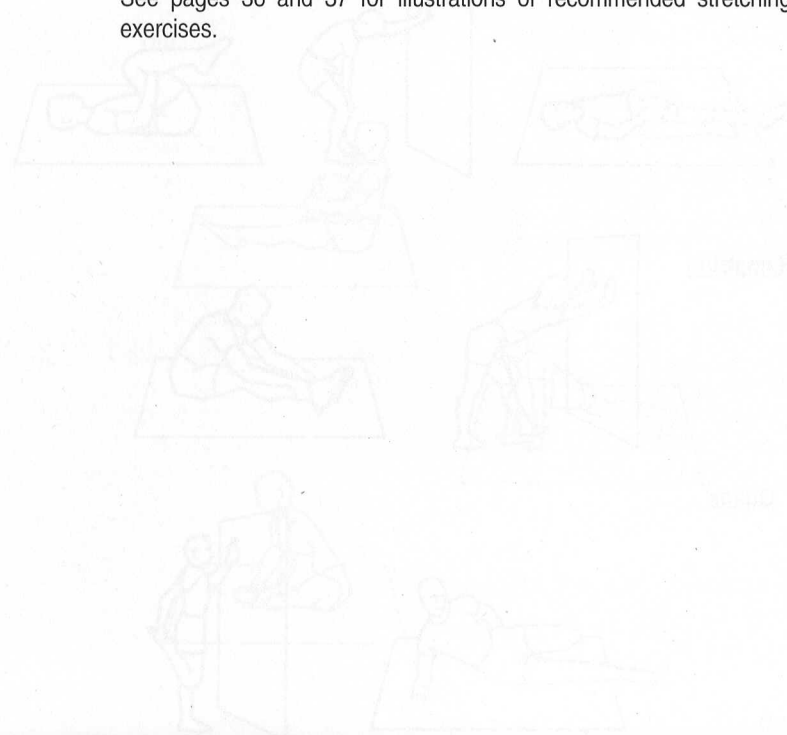

Stretching Exercises

Follow the sequence indicated in these stretching illustrations.

When stretching, remind yourself to move slowly into a stretch where you feel resistance, but no pain. Hold that position and breathe deeply and slowly for 5-10 seconds. Stretch both sides of your body when the illustration calls for arm or leg stretching. When the illustration calls for shoulder rotation, perform five rotations in each direction.

Figure 5: Recommended Stretching Exercises

Calf

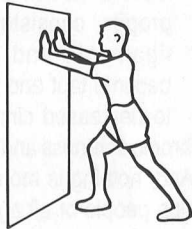

Lower Back

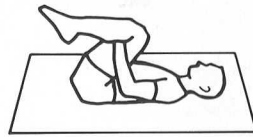
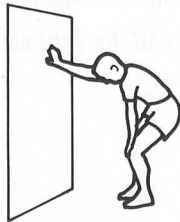
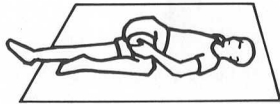

Hamstring

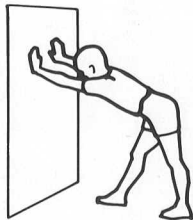

Quads

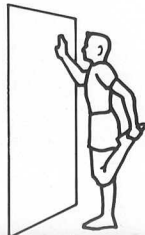
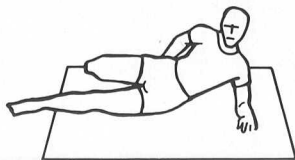

Shoulders

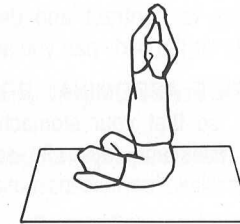
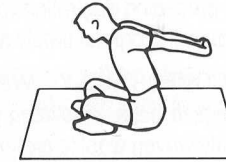
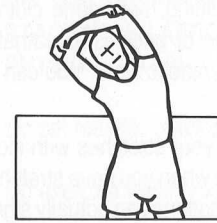

Hip

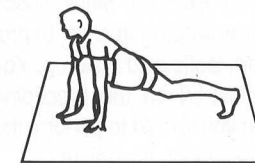
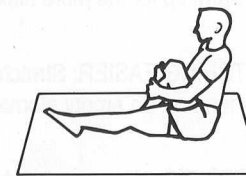

Tips for Good Stretching Results

Stretching is a special discipline that requires concentration and patience for best results. Follow these tips and practice the stretches shown in the preceding illustrations at least 3 times a week for 15-minute sessions. You will progress safely and surely.

1. DRESS COMFORTABLY: Wear loose-fitting, soft fabric clothes without restrictive belts, elastic, large buttons or buckles. Breathable cotton or softly woven wool is preferable to synthetic cloth. You can go without shoes or slippers when stretching.

2. STRETCH SLOWLY: Move in and out of your stretches with slow, controlled motions and hold in a static position when you have stretched as far as comfortable. Fast, bouncy, ballistic motions can actually signal the muscles to contract and defeat the purpose of stretching. Concentrate on the body part you are working.

3. PRACTICE ABDOMINAL BREATHING: Breathe from your diaphragm, so that your stomach, rather than your rib cage and shoulders, rises and falls with each breath. Abdominal breathing encourages relaxation, lessens muscular tension, and helps lower blood pressure.

4. LEARN THE "STRETCHING ZONE": Stretch gradually to the point of feeling resistance, but never to the point of pain. Never use muscular effort to increase a stretch. Some discomfort is natural, but the gentle forces of gravity and body weight will determine the limits of a safe, effective stretching zone.

5. START EASY: Start each session with the stretches you find easiest. This will help you relax, concentrate, and warm up for the more difficult parts of your routine.

6. AN EMPTY STOMACH MAKES STRETCHING EASIER: Stretching routines are easier and more pleasant if done on an empty stomach. This refers to liquid and solid foods.

7. PRE- AND POST-WORKOUT STRETCHES: Always stretch in preparation for exercise. Since muscles tighten up after exertion, also stretch after exercising in order to promote circulation and to minimize stiffness from lactic acid build-up. You don't have to perform all of the stretches pictured on the preceding pages before and after your workout, but you should to perform those which most directly affect the muscles used during a workout.

Do's and Don'ts for Minimizing Soreness and Muscular Stress

The following do's and don'ts will help reduce the chance of soreness, and will increase the effectiveness of a workout.

- DO OBTAIN PROPER MEDICAL CLEARANCE PRIOR TO STARTING AN AEROBIC EXERCISE PROGRAM BY HAVING A PHYSICAL EXAM.**
- Do set realistic goals and objectives.
- Do exercise within your THRR.
- Do warm up and cool down properly.
- Do stretching exercises before beginning a Lifestride program.
- Do stretching exercises after completing the cool-down.
- Don't increase duration or intensity by more than one level per week. (only Hill Profile and Random programs).
- Don't increase intensity and duration at the same time.
- Don't overextend effort in hot and/or humid weather.

How to Choose an Aerobic Training Method

How hard you work out during your Lifestride exercise sessions depends on your fitness goals and physical condition. If you don't enjoy your workouts, you won't continue. Basically, you should design workouts you can live with.

This section describes an aerobic training method that is available on the Lifestride aerobic trainer — interval striding.

Interval Striding

Interval striding combines the best features of walking and interval training. Like walking, interval striding is a natural, comfortable motion which is easy for virtually everyone to master. By combining walking with progressive hills, interval striding allows you to achieve the important benefits of interval training. Previous research studies on the progressive Hill Profile have shown that it is superior to steady-paced training for improving aerobic capacity.

By adding incline to striding, you partially lift your own weight with each stride. This is great for shaping and toning the major muscle groups of the legs and buttocks. This is the same physiology that has made stair-climbing and step aerobics so popular.



Interval Striding Compared to Running

Interval striding has many features that make it superior to running for most individuals. Compared to running, interval striding is much less stressful on the bones and joints. This reduced stress is enhanced through the Lifestride trainer's flexible striding surface. When you run (whether on a treadmill or outside) you leave the ground with every stride and land with three to four times your body weight. With interval striding, one foot is always in contact with the ground, so you land with only one to one and a half times your body weight.

Figure 6: Interval Striding Versus Jogging - Caloric Expenditure

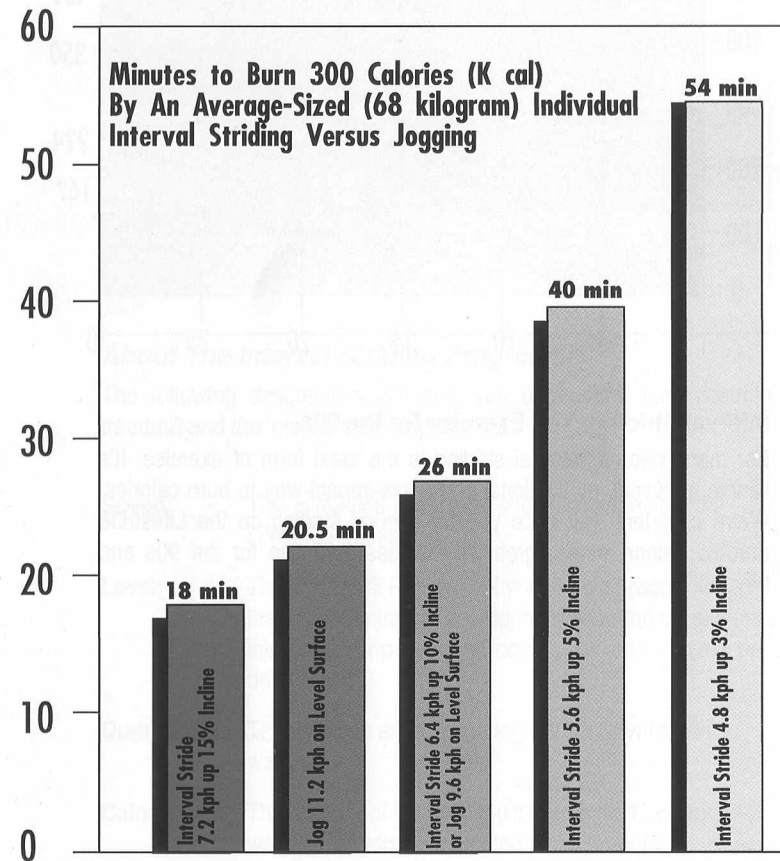

Many people don't realize how effective the addition of incline in interval striding is in terms of caloric burn. The figures on the preceding page and below show that interval striding at fairly low speeds often helps burn more calories than running on a level surface at much higher speeds.

Figure 7: Interval Striding Versus Jogging -Time Requirement

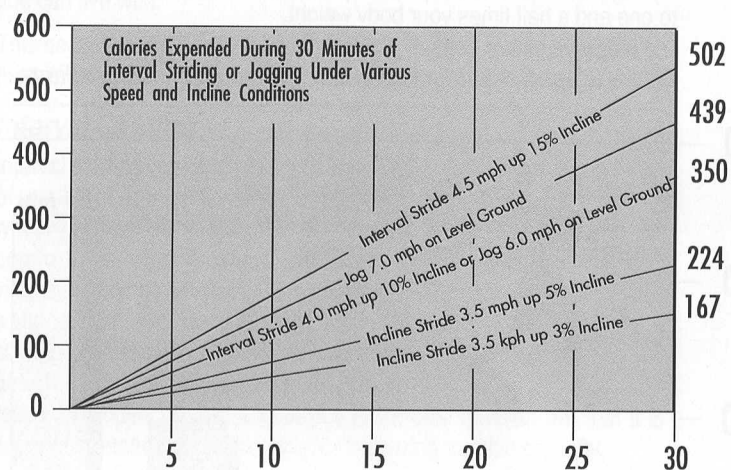

Interval Striding: The Exercise for the 90s

For many people, interval striding is the ideal form of exercise. It's simple, practical, motivational and a low-impact way to burn calories. We're confident that once you try interval striding on the Lifestride aerobic trainer, you'll agree it's the ideal exercise for the 90s and beyond!

Determining an Interval Striding Program Level

You are now ready to select your optimal interval striding program. Each of the programs has been designed to keep your heart rate in the target training zone, offer the benefits of progressive hill interval training, build leg strength and be fun and motivational. Once you start the interval striding program, it should serve as the cornerstone of your aerobic fitness program. However, feel free to supplement it with other aerobic activities.

To start a personalized interval striding program, locate your Fit Test score (VO₂ Max) in the left column of the chart below. The corresponding letter tells you which interval striding program to follow. (To obtain a Fit Test score refer to page 21.)

FIT TEST SCORE	PROGRAM
less than 20	A
20 - 29	B
30 - 39	C
40 - 49	D
more than 50	E

About The Interval Striding Programs

The following descriptions will help you understand the Lifestride treadmill and the interval striding programs.

- Speed:** This is the belt speed you should program into the Lifestride trainer.
- Level:** This is the Hill Profile level you should program into the Lifestride trainer in order to provide the correct interval striding level. Hill inclines will automatically be determined.
- Duration:** The time you exercise during each interval striding workout.
- Calories:** The number of calories you'll burn for a 12-minute workout. (If you have elected to work out for 24 minutes simply double this number.)
- Heart Rate:** Percent of maximum heart rate. (To determine your maximum heart rate, subtract your age from 220.)
- Frequency:** How often during a week you should perform the interval striding program.

Lifestride Interval Striding Programs (Using the Hill Profile)

The following programs (A - E) are examples of progressive Lifestride Interval Striding programs (Hill Profile mode). Use these as a reference when creating your personal exercise program.

Program A

WEEK	1	2 - 3	4 - 6	7 - 9	10 - 12	
Speed (mph)	2-3	2-3	2-3	2-3	2-3	
Level	1	2	3	4	5	
Duration (mins)	12-24	12-24	12-24	12-24	12-24	
Calories (12 mins):						
2 mph	42	43	44	47	51	
3 mph	56	57	59	63	69	
Heart Rate %	60-70	60-70	60-70	70-80	70-80	
Frequency	4-5	4-5	4-5	4-5	4-5	

Program B

WEEK	1	2 - 3	4 - 6	7 - 9	10 - 12	Maintenance
Speed (mph)	3-4	3-4	3-4	3-4	3-4	3-4
Level	2	3	4	5	6	6
Duration (mins)	12-24	12-24	12-24	12-24	12-24	12-24
Calories (12 mins):						
3 mph	57	59	63	69	75	75
4 mph	71	74	79	87	95	95
Heart Rate %	60-70	60-70	65-75	70-80	70-80	70-80
Frequency	4-5	4-5	4-5	4-5	4-5	3-5

Program C

WEEK	1	2 - 3	4 - 6	7 - 9	10 - 12	Maintenance
Speed (mph)	3-4	3-4	3-4	3-4	3-4	3-4
Level	6	7	8	9	10	10
Duration (mins)	12-24	12-24	12-24	12-24	12-24	12-24
Calories (12 mins):						
2 mph	75	81	87	93	99	99
3 mph	95	103	111	120	128	128
Heart Rate %	60-70	60-70	65-75	70-80	70-80	70-80
Frequency	3-5	3-5	3-5	3-5	3-5	3-5

Program D

WEEK	1	2 - 3	4 - 6	7 - 9	10 - 12	Maintenance
Speed (mph)	4-4.5	4-4.5	4-4.5	4-4.5	4-4.5	4-4.5
Level	8	9	10	11	12	12
Duration (mins)	12-24	12-24	12-24	12-24	12-24	12-24
Calories (12 mins):						
2 mph	111	120	128	136	144	144
3 mph	124	133	142	151	160	160
Heart Rate %	60-70	60-70	65-75	70-80	70-80	70-80
Frequency	3-5	3-5	3-5	3-5	3-5	3-5

Program E

WEEK	1	2 - 3	4 - 6	7 - 9	10 - 12	Maintenance
Speed (mph)	4.5-6	4.5-6	4.5-6	4.5-6	4.5-6	4-4.5
Level	6	7	8	9	10	10-12
Duration (mins)	12-24	12-24	12-24	12-24	12-24	12-24
Calories (12 mins):						
4.5 mph	136	141	145	150	154	154-163
6.0 mph	203	215	227	239	252	252-276
Heart Rate %	60-70	60-70	65-75	70-80	70-80	70-80
Frequency	3-4	3-4	3-4	3-4	3-4	3-4

Interval Striding Using the Manual and Random Programs

The interval striding programs described in this manual are designed for the Hill Profile program. If you wish to create your own variations on these programs, you may utilize either the Manual or Random modes on the Lifestride treadmill.

If you choose to create an interval striding program utilizing the Manual program, it is recommended that you first set a comfortable striding speed, then select the inclines and durations desired using the appropriate keys on the key pad.

If you choose to perform interval striding utilizing the Random program, it is recommended that you choose a level one or two lower than normally used on the Hill Profile, due to the increased difficulty of this program.

Most people will discover the ease of use and motivation inherent in performing interval striding in the Hill Profile, making this the preferred choice.

Lifetime Exercise for Health and Fitness

Numerous scientific and medical studies demonstrate that lifetime consistency is the key to achieving the most important health benefits from exercise. Interval striding is the ideal form of exercise for lifetime health and fitness. It features the easy, natural activity of striding and adds the features of interval training. Its low-impact nature reduces the injury potential. The motivational nature of the Hill Profile on the Lifestride trainer assures the enthusiasm and enjoyment so essential to maintaining a lifelong exercise habit.

The Lifestride Trainer: The Ultimate Striding Machine

The Lifestride treadmill is loaded with features designed to make interval striding comfortable, motivational and safer. The flexing deck minimizes impact to bones and joints. The quiet, powerful motor allows belt speeds from 0.5 to 11.0 mph. The ergonomically designed side rails remain out of the way. The Lifestride aerobic trainer is truly the machine of the 90s and beyond for walking, running and interval striding.

How to Exercise Effectively

Exercising too hard is as ineffective as not working hard enough. In fact, it can be harmful. For an effective workout, you must determine your optimal workout frequency, duration and intensity and stick to it!

Training Heart Rate Range (THRR) Calculation

To approximate your Training Heart Rate Range (THRR), you must first calculate your theoretical maximum heart rate (the following formula is recognized by the American College of Sports Medicine as a method for determining your maximum heart rate).*

Subtract your age from 220. For example, if you are 35 years old, your theoretical maximum heart rate is 185. Establish your THRR by multiplying this number (185) first by 60% to establish the lower limit and then by 85% to establish the upper limit.

Examples for age 35:

Fat Loss Training Range :

Lower limit: $(220 \text{ less } 35 = 185) \times .60 = 111 \text{ beats/min.}$

Upper limit: $(220 \text{ less } 35 = 185) \times .75 = 139 \text{ beats/min.}$

Cardiorespiratory Training Range:

Lower Limit $(220 \text{ less } 35 = 185) \times .75 = 139 \text{ beats/minute}$

Upper Limit $(220 \text{ less } 35 = 185) \times .85 = 157 \text{ beats/minute}$

NOTE: A stress test administered by a doctor is the most accurate method of determining your maximum heart rate and overall cardiorespiratory condition. We strongly recommend that you see a doctor before beginning any exercise program, especially if you have a history of high blood pressure, heart problems, or if you are over the age of 45. You and your doctor can decide whether a maximum stress test is advisable.

By making sure your heart rate stays within your range during workouts, you will achieve optimal training benefits with minimal stress to your cardiorespiratory system. As your fitness program progresses, your aerobic capacity will build and your body will begin to show the benefits of what is referred to by fitness experts as the training effect.

Table 5 on page 55 can be used to determine your training heart rate range for fat loss and cardiorespiratory improvement.

* American College of Sports Medicine, Guidelines for Exercise Testing and Prescription (Lea & Febiger:Philadelphia, 1986), p.32.

Checking Your Pulse

For best results, stay within your THRR during exercise. To do this, check your pulse periodically during your workout. (See Figure 4 on page 14 for the times to check your heart rate during the Hill Profile program.)

You may wish to use the optional chest strap, but your own two fingers will suffice. A pulse can be conveniently monitored in two locations: (1) halfway between the ear and windpipe on the neck or (2) on the thumb side of the inside of the wrist. To monitor your pulse, hold your index and middle fingers together against either site. (The neck site is easiest during exercise.)

CAUTION: Do not press too hard, especially when taking a neck pulse. Excessive pressure can reduce blood flow and cause the heart to slow down.

A 15-second count is recommended. Your heart rate per minute is four times the 15-second count.

Figure 8: Training Zone Chart

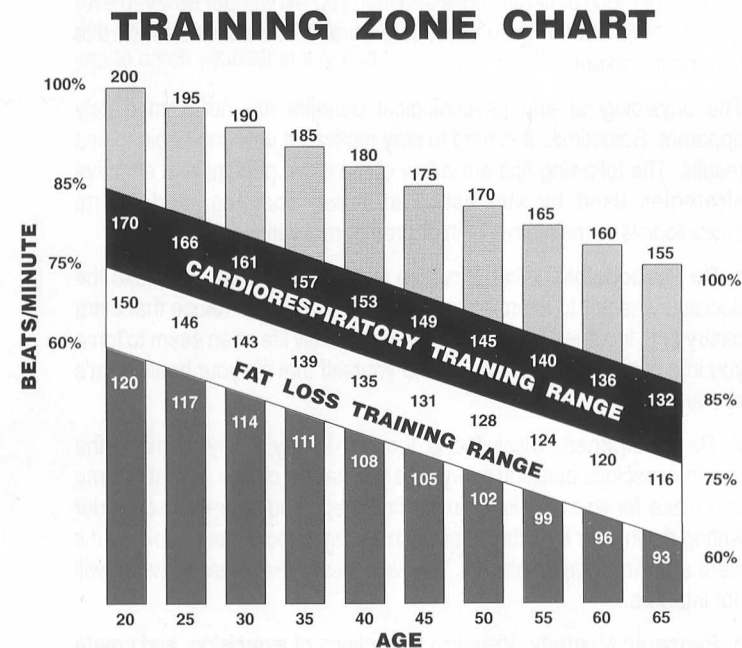

Training above 85% of your theoretical maximum heart rate is not recommended.

CARDIORESPIRATORY TRAINING RANGE -- between 75% and 85% of your theoretical maximum heart rate.

FAT LOSS TRAINING RANGE -- between 60% and 75% of your theoretical maximum heart rate.

For most people, training benefits are difficult to achieve if performed below 60% of their theoretical maximum heart rate.

How to Stay Motivated

Maintaining consistent exercise habits is a big challenge. Adherence to a training program results in tremendous rewards. Once you begin to notice how much better you look and feel, you will wonder how you ever got along without a regular exercise program. You will look forward to your next workout.

The physiological and psychological benefits are not immediately apparent. Sometimes it is hard to stay motivated until you begin to see results. The following tips are a few of the more popular and effective strategies used by successful athletes, coaches, and sports physiologists to maintain a high degree of motivation.

1. Be Responsible. When it comes to the bottom line, you make the decision whether to exercise or watch TV, whether to refuse that extra pastry or to indulge. While the pressures of daily life often seem to force you into putting off exercise, remind yourself that it's your health that's at stake.

2. Be Disciplined. Discipline is the day-to-day ability to make the health-conscious decision every time you have a choice. A routine time and place for exercise is a simple first step. You may even consider writing down your exercise session in a daily appointment book, as if it were a business appointment. This will ensure that other activities will not interfere.

3. Rehearse Mentally. Visualize the actions of exercising, and create a mental picture of yourself in peak physical condition, enjoying the benefits of vibrant physical health. Many athletes and performers actually rehearse their skills with mental pictures prior to taking the field or walking onstage. It prepares them for the activity by eliminating apprehension and makes the activity more exciting, and even more enjoyable.

4. Gain Fitness Knowledge. The press and broadcast media are constantly full of new diets, exercise plans, product descriptions and testimonials about state-of-the-art health programs. There is so much to learn, and so many people and companies are making claims for their own particular offerings, that you must become a shrewd student of fitness to determine what works best for you. Reading authoritative periodicals by expert authors, attending seminars and trade shows, and evaluating each new product and system you encounter will help.

5. Be Realistic. The degree of endurance, strength and body tone you can achieve is always determined by your genetic potential, fitness program, and environment. You should not compare yourself just to top athletes or celebrities. You should judge real development by improvement from where you started. The Fit Test program is an excellent tool to demonstrate this improvement. You will develop a

sense of pride and accomplishment when you achieve goals you have set for yourself, and nothing is more motivating than success.

6. Keep a Progress Chart. A daily log, like the one included at the end of this manual, helps you monitor your progress objectively. Subjective comments about how you feel during and after your workouts can keep you aware of subtle changes as you improve, and this is a good way for you to catch yourself in a slump.

How to Develop a Personal Exercise Plan (PEP)

No two people are exactly alike, so no two aerobic exercise plans should be identical. People vary widely in their health and fitness status. Goals, motivation, age, physical condition, exercise experience and time constraints are different. That's why using the Lifestride aerobic trainer is an ideal form of exercise. It is designed to deliver a computerized workout tailored specifically to your training capacity.

This section provides the general guidelines you need to develop your Personal Exercise Plan (PEP). Remember, you are your own best coach since you know your limitations and expectations better than anyone.

The American College of Sports Medicine and American Medical Association have established medical screening guidelines for exercise, and we strongly recommend that you consider the start of your PEP as an appropriate time to see your physician.

Medical clearance for use of the Lifestride aerobic trainer should be obtained by individuals over 45 who have a major risk factor for coronary disease, such as heart disease, high blood pressure, high cholesterol levels, cigarette smoking or a family history of heart disease. Medical clearance should be obtained by all persons, regardless of age, with cardiorespiratory disorders, diabetes, bone and/or joint disease, or persons who have had any symptoms of coronary disease.

In general, anyone starting a vigorous exercise regimen should see a physician for a medical exam. The extent of the exam will depend on the physician's preliminary evaluation of the individual's health status.

PLANNING AN AEROBIC WORKOUT

GOALS:

Goals determine the direction and type of exercise plan that is suitable for you. An individual wishing to reduce his or her risk of heart disease will train less strenuously than a competitive athlete.

There are two major goals of aerobic exercise:

1. **Cardiorespiratory improvement**
2. **Fat loss**

Varying the frequency and intensity of the aerobic workout changes the focus from one goal to the other. High intensity aerobic exercise for shorter periods of time promotes cardiorespiratory improvement and burns mostly muscle glycogen as fuel. Low intensity aerobic exercise for longer periods of time promotes fat loss, because longer periods of exercise burn more calories from stored fat.

If you are working to reduce the probability of heart disease or to improve endurance, your goal is to build stronger heart and lungs (cardiorespiratory improvement). By expanding lung capacity, your body's intake and utilization of oxygen is increased. Regular aerobic exercise accomplishes this and improves muscle endurance at the same time. (See Figure 8 on page 49 for a Heart Rate Training Zone chart with suggested heart rates for both fat loss and cardiorespiratory training.)

Fit Guidelines

FIT stands for FREQUENCY of exercise, INTENSITY of exercise and the amount of TIME (duration) spent exercising. These are the three variables in designing an effective PEP. Here's how to use the FIT guidelines to develop your PEP:

FREQUENCY. . .refers to how many times you use the Lifestride trainer each week. If the objective is to improve cardiorespiratory fitness, use the Lifestride treadmill at least three times a week, with no more than two days between workouts. At first, you should give your muscles a chance to adapt to increased activity.

When you begin your FIT regimen, you should not exercise more than once every other day. This should prevent muscle soreness and fatigue. Even after you have progressed sufficiently, the American College of Sports Medicine still recommends that your workout not exceed five times per week. Increased frequency yields minimal additional cardiorespiratory improvement and increases the risk of muscle strain. Only highly trained, competitive athletes should consider daily workouts. However, if your goal is fat loss, you should exercise more frequently, for longer periods of time, at a lower level of intensity.

INTENSITY. . .refers to how hard you work your heart. A heart rate of 75% of the theoretical maximum heart rate is the threshold above which optimum cardiorespiratory training occurs for those who are medically fit. A safe upper limit for these same people is 85%.* Select a level of intensity that puts your heart rate between 75% and 85% of your theoretical maximum for cardiorespiratory improvement. Beginners will want to exercise at a heart rate which is closer to 75% , while highly trained athletes may want to exercise closer to 85% of their theoretical maximum heart rate.

*American College of Sports Medicine, Guidelines for Exercise Testing and Prescription, Third Edition (Lea & Febiger: Philadelphia, 1986), p. 32.

See Table 5 on page 55 for an approximation of the theoretical Maximum Heart Rate and Training Heart Rate Range (THRR) for various age categories.

You should adjust the intensity (level) of your workout to keep your heart rate within its most effective range. You will find that it is easier to stride at a level of intensity on the Hill Profile program than at that same level on the Manual program.

TIME... refers to the number of minutes you spend on your THRR. Optimal cardiorespiratory and endurance improvements come with prolonged use of 12 to 24 minute workouts. A beginner might start with the 6 or 12 minute Hill Profile program. As you adapt, you should extend the duration of your workout. The 18 through 60 minute Hill Profile programs are available for this purpose. You should be sure to keep your heart rate within your THRR by adjusting the intensity level.

It is recommended that those just beginning to use the Lifestrider aerobic trainer, even if in excellent condition, start with the standard Hill Profile program.

If your objective is FAT LOSS, it is better to stride for a longer duration. You will find that a lower level of intensity allows you to workout longer. You can increase the intensity as you progress. A heart rate range of 60% to 75% of the theoretical maximum heart rate is the preferred range for fat loss training.

Table 5: Training Heart Rate Range (THRR) for Fat Loss and Cardiorespiratory Improvement

Age	Max HR*	60% HR	75% HR	85% HR	Optimal Training HR**
20	200	120	150	170	160
21	199	119	149	169	159
22	198	118	148	168	158
23	197	118	148	167	158
24	196	117	147	166	157
25	195	117	146	165	156
26	194	116	145	164	155
27	193	115	145	164	154
28	192	115	144	163	154
29	191	114	143	162	153
30	190	114	142	161	152
31	189	113	142	160	151
32	188	112	141	159	150
33	187	112	140	158	150
34	186	111	139	158	149
35	185	111	139	157	148
36	184	110	138	156	147
37	183	109	137	155	146
38	182	109	136	154	146
39	181	108	136	153	145
40	180	108	135	153	144
41	179	107	134	152	143
42	178	106	133	151	142
43	177	106	133	150	142
44	176	105	132	149	141
45	175	105	131	148	140
46	174	104	130	147	139
47	173	103	130	147	138
48	172	103	129	146	138
49	171	102	128	145	137
50	170	102	127	144	136
51	169	101	127	143	135
52	168	100	126	142	134
53	167	100	125	141	134
54	166	99	124	141	133
55	165	99	124	140	132
56	164	98	123	139	131
57	163	97	122	138	130
58	162	97	121	137	130
59	161	96	121	136	129
60	160	95	120	136	128
61	159	95	119	135	127
62	158	94	118	134	126
63	157	94	118	133	126
64	156	93	117	132	125
65	155	93	116	131	124
66	154	92	115	130	123
67	153	91	115	130	122
68	152	91	114	129	122
69	151	90	113	128	121
70	150	90	112	127	120

*Theoretical maximum heart rate is recognized by the American College of Sports Medicine.

**Optimal training heart rate is hypothetical, based on an average person in the population; however, exercising at a specific heart rate is a precise determination that can only be made by qualified medical personnel.

A greater percentage of calories are burned when you average between 60% and 75% of your theoretical maximum heart rate. Fat is burned best when there is plenty of oxygen available in the blood. Working out at a lower heart rate for a longer period of time tends to optimize the amount of fat burned. Lower intensity exercise allows you to work out longer, thus allowing you to burn more total calories.

*American College of Sports Medicine, Guidelines for Exercise Testing and Prescription, Third Edition (Lea & Febiger, Philadelphia, 1986), p. 32.

Table 6: Weight Conversion

kgs.	lbs.	kgs.	lbs.	kgs.	lbs.	kgs.	lbs.	kgs.	lbs.	kgs.	lbs.
34	75	48.5	107	63	139	77.5	171	92	202	106.5	234
34.5	76	49	108	63.5	140	78	172	92.5	204	107	235
35	77	49.5	109	64	141	78.5	173	93	205	107.5	237
35.5	78	50	110	64.5	142	79	174	93.5	206	108	238
36	79	50.5	111	65	143	79.5	175	94	207	108.5	239
36.5	80	51	112	65.5	144	80	176	94.5	208	109	240
37	81	51.5	113	66	145	80.5	177	95	209	109.5	241
37.5	83	52	114	66.5	146	81	178	95.5	210	110	242
38	84	52.5	116	67	147	81.5	179	96	211	110.5	243
38.5	85	53	117	67.5	149	82	180	96.5	212	111	244
39	86	53.5	118	68	150	82.5	182	97	213	111.5	245
39.5	87	54	119	68.5	151	83	183	97.5	215	112	246
40	88	54.5	120	69	152	83.5	184	98	216	112.5	248
40.5	89	55	121	69.5	153	84	185	98.5	217	113	249
41	90	55.5	122	70	154	84.5	186	99	218	113.5	250
41.5	91	56	123	70.5	155	85	187	99.5	219	114	251
42	92	56.5	124	71	156	85.5	188	100	220	114.5	252
42.5	94	57	125	71.5	157	86	189	100.5	221	115	253
43	95	57.5	127	72	158	86.5	190	101	222	115.5	254
43.5	96	58	128	72.5	160	87	191	101.5	223	116	255
44	97	58.5	129	73	161	87.5	193	102	224	116.5	256
44.5	98	59	130	73.5	162	88	194	102.5	226	117	257
45	99	59.5	131	74	163	88.5	195	103	227	117.5	259
45.5	100	60	132	74.5	164	89	196	103.5	228	118	260
46	101	60.5	133	75	165	89.5	197	104	229	118.5	261
46.5	102	61	134	75.5	166	90	198	104.5	230	119	262
47	103	61.5	135	76	167	90.5	199	105	231	119.5	263
47.5	105	62	136	76.5	168	91	200	105.5	232	120	264
48	106	62.5	138	77	169	91.5	201	106	233		

Training Log

Session No.	Date	Resting Heart Rate	Body Weight	Program Selection /Level	Length of Ride	Heart Rate #1	Heart Rate #2	Fi Test Score	Comments
1	3/1	70	185	Hill 3	12 min	108	143	NO	Felt great starting, but fatigued too fast.
2	3/2	72	184 1/2	Hill 3	12 min	110	152	NO	A half pound lost! Peak!
3	3/4	71	184	Hill 4	18 min	109	150	NO	Felt quite about missing yesterday. Tough extra mins.
4	3/5	70	184	Man 4	12 min	108	149	46	NOT BAD! That's in the good range for a 45 yr. old like me.
5									
6									
7									
8									
9									
10									
11									
12									
13									
14									

SAMPLE

©1989, Life Fitness, Inc. All rights reserved. *Take 3 days consecutively and average. Measure every 4 to 6 weeks.

Session No.	Date	Resting Heart Rate	Body Weight	Program Selection /Level	Length of Ride	Heart Rate #1	Heart Rate #2	Fi Test Score*	Comments
1									
2									
3									
4									
5									
6									
7									
8									
9									
10									
11									
12									
13									
14									

©1989, Life Fitness, Inc. All rights reserved. *Take 3 days consecutively and average. Measure every 4 to 6 weeks.