

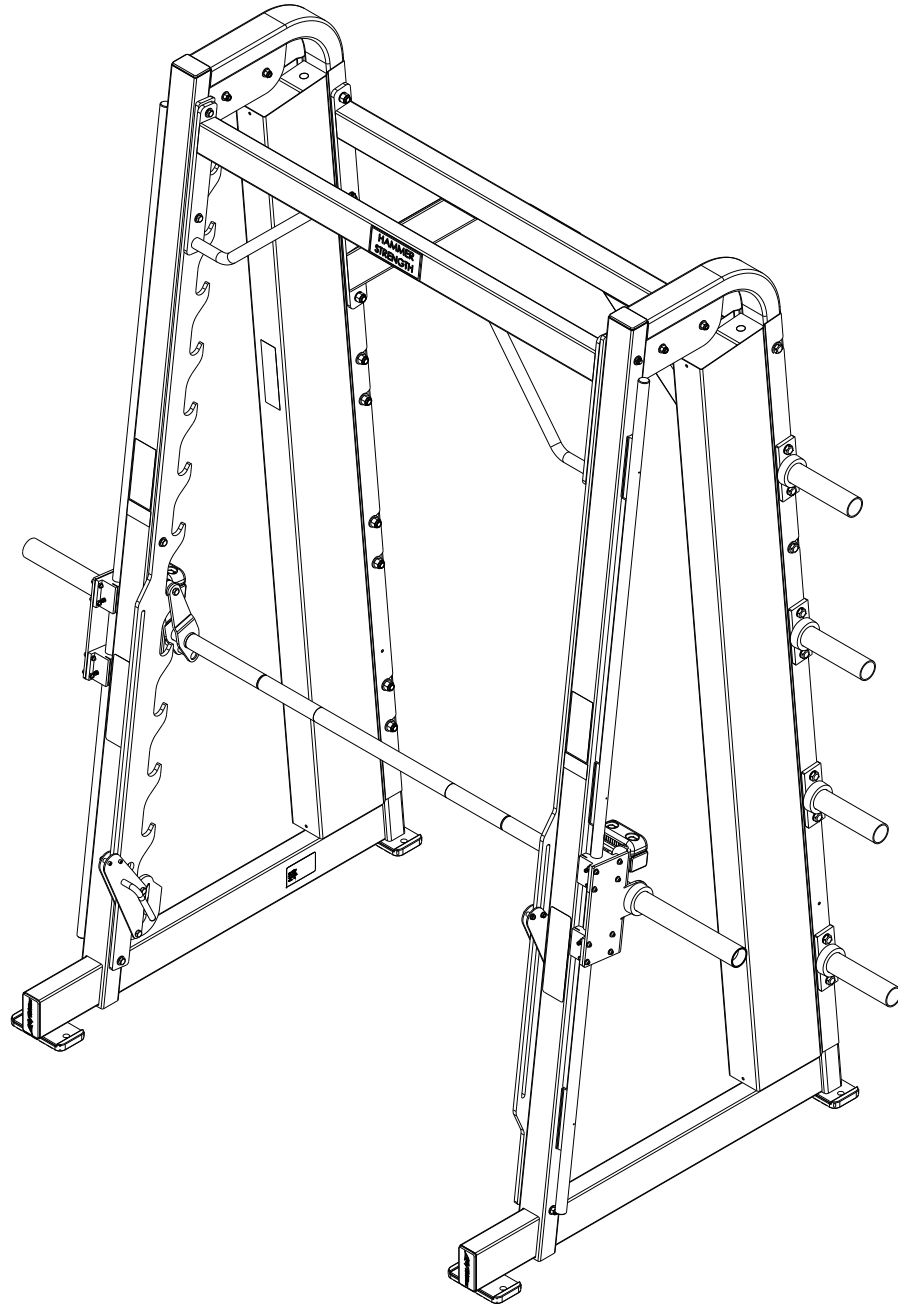

HAMMER STRENGTH
PLSM
PLATE LOADED SMITH MACHINE



Customer Support Services
PARTS LIST

PLSM PLATE LOADED SMITH MACHINE

Contents

	PAGE
COMPONANT ASSEMBLY	3
COMPONANT ASSEMBLY LEGEND	4
LEFT SIDE FRAME ASSEMBLY	5
LEFT SIDE FRAME ASSEMBLY LEGEND	6
LEFT BAR STOP ASSEMBLY	7
PLSM LEFT CARRIAGE ASSEMBLY	8
PLSM BAR ASSEMBLY	9
RIGHT SIDE FRAME ASSEMBLY	10
RIGHT SIDE FRAME ASSEMBLY LEGEND	11
RIGHT BAR STOP ASSEMBLY	12
PLSM RIGHT CARRIAGE ASSEMBLY	13
PLSM COUNTER WEIGHT ASSEMBLY	14
WEIGHT HORN ASSEMBLY	15
IMAGE	16

PLSM PLATE LOADED SMITH MACHINE COMPONENT ASSEMBLY

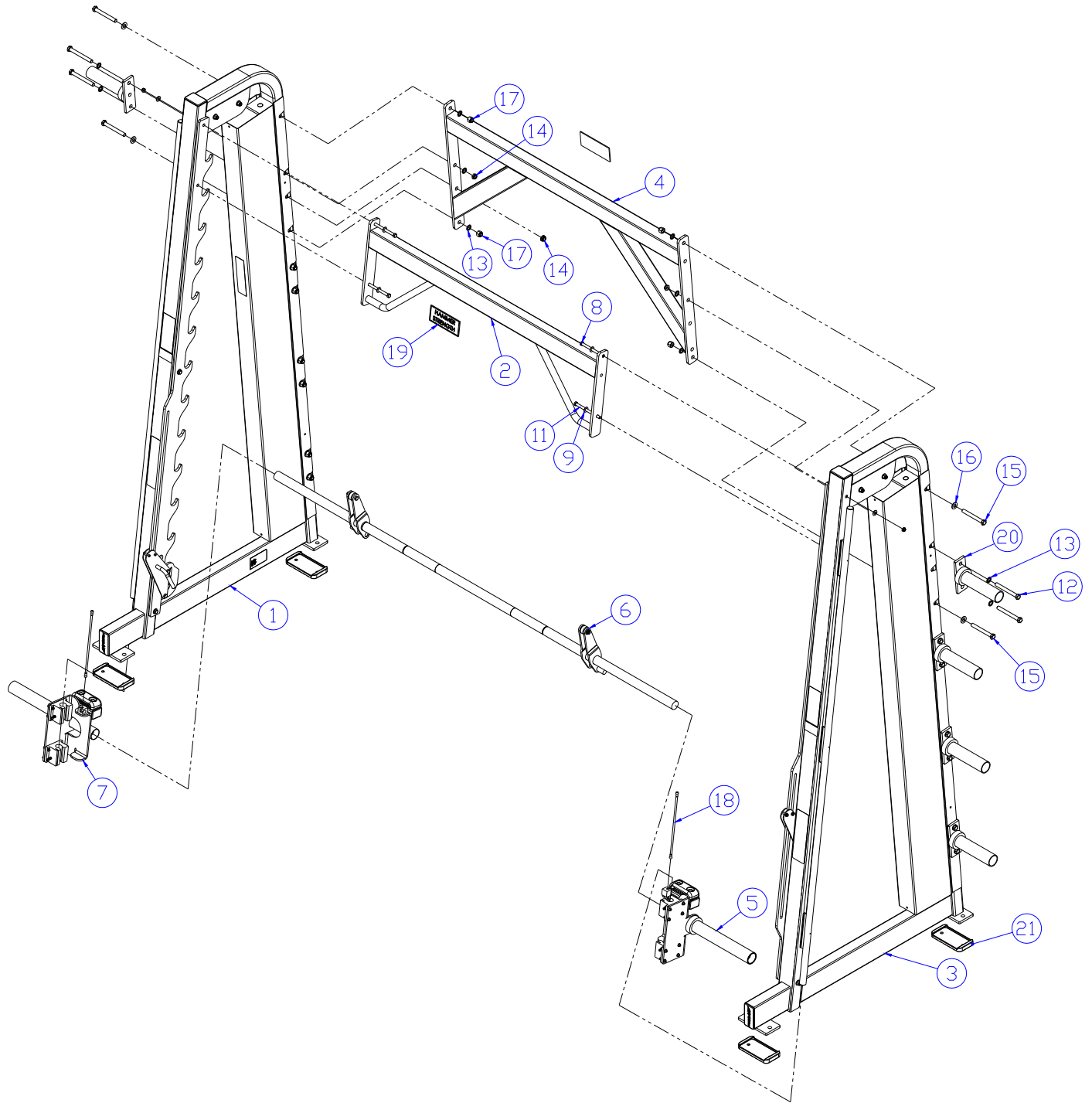

SEE PAGE 4 FOR LEGEND

PLSM PLATE LOADED SMITH MACHINE COMPONENT ASSEMBLY LEGEND

ITEM NO.	QTY.	PART NO.	DESCRIPTION
1	1	7666901	ASSY, PLSM SIDE FRAME RIGHT
2	1	7669601	WLDMT, PLSM FRONT BRACE
3	1	7669101	ASSY, PLSM SIDE FRAME LEFT
4	1	7670101	WLDMT, PLSM BACK BRACE
5	1	7665601	ASSY, PLSM CARRIAGE RIGHT
6	1	7666401	ASSY, PSLM BAR
7	1	7666201	ASSY, PLSM CARRIAGE LEFT
8	2	3223315	3/8-16 X 4.50 HEX HEAD BOLT
9	6	3236601	WASHER, 3/8 SAE SS
10	2	3102807	NUT, NYLOCK 3/8-16 LOW HT
11	2	3223317	3/8-16 X 5.00 HEX HEAD BOLT
12	4	3239318	1/2-13 X 4.50 UNS HEX FHB G5 ZN
13	12	3239505	WSH, .500 IN-D ST ZN
14	4	3102804	NUT, NYLOCK-JAM 1/2-13 ST ZN
15	4	3239317	1/2-13 X 4.25 UNS HEX FHB G5 ZN
16	4	3102507	WASHER, TYPE A PLAIN
17	4	3102801	NUT, NYLOCK 1/2-13 ST ZN
18	2	7671701	CABLE, PLSM
19	2	M051-00289-A000	HAMMER STRENGTH NAME PLATE
20	2	7760201	ASSY, WEIGHT HORN
21	4	7388201	Footpad, PS Rubber

PLSM PLATE LOADED SMITH MACHINE LEFT SIDE FRAME ASSEMBLY - 7669101

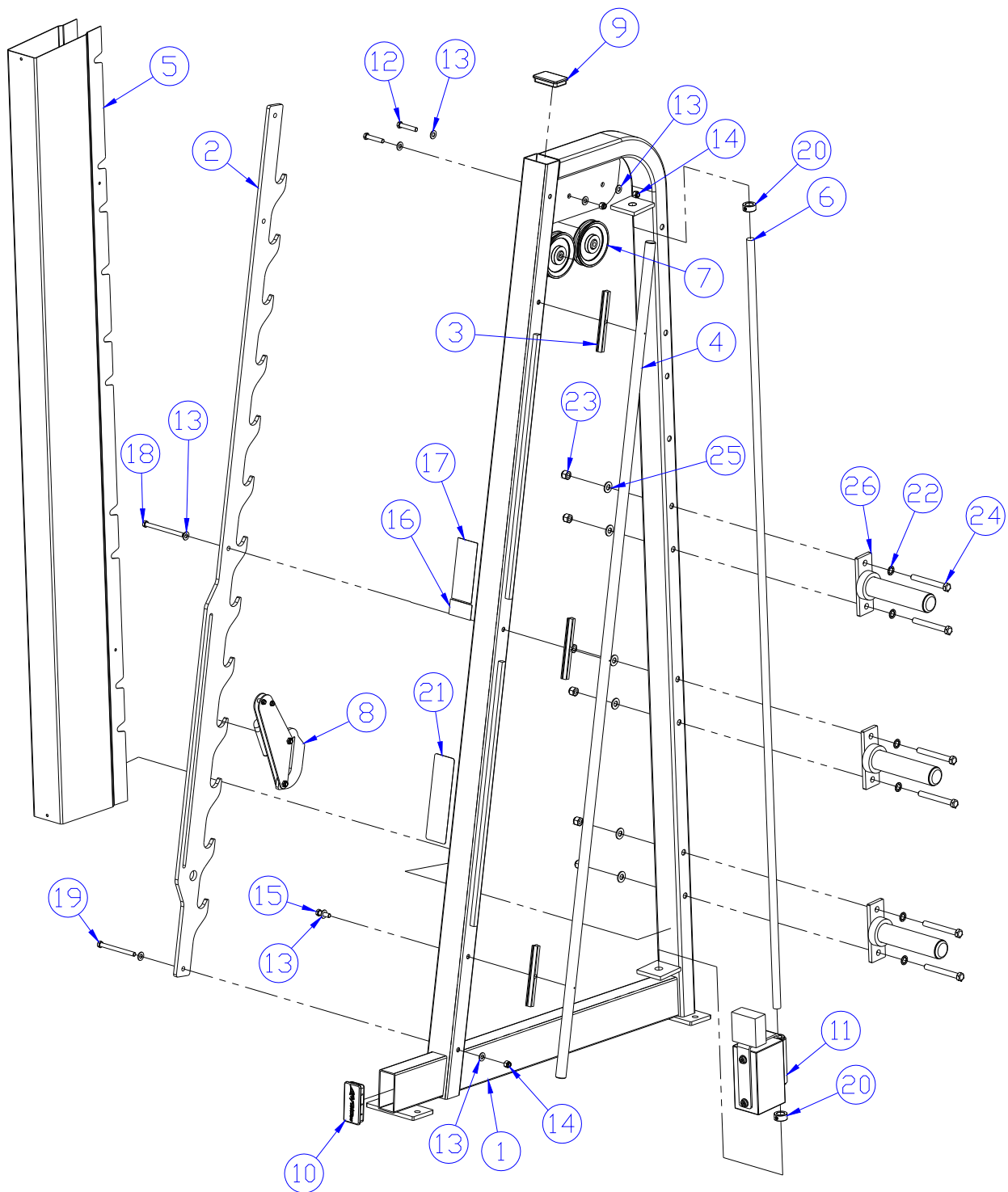

SEE PAGE 6 FOR LEGEND

PLSM PLATE LOADED SMITH MACHINE LEFT SIDE FRAME ASSEMBLY LEGEND

ITEM NO.	QTY.	PART NO.	DESCRIPTION
1	1	7669201	WLDMT, PLSM SIDE FRAME LEFT
2	1	7667601	GUNRACK, PLSM
3	3	7959301	RAIL SUPPORT, PLSM
4	1	7667901	GUIDE ROD, 1" OD X 83
5	1	7668002	SHIELD, PLSM CW BLK
6	1	7328617	GUIDE ROD, .75 OD SOLID 79.88
7	2	3237801	PULLEY, 4.5" OD
8	1	8013701	ASSY, PLSM BAR STOP - LT
9	1	7352301	CAP, END 2 X 3
10	1	7352401	CAP, END 2 X 4
11	1	7668401	ASSY, PLSM COUNTER WEIGHT
12	2	3223305	3/8-16 X 2.50 HEX HEAD BOLT
13	8	3236601	WASHER, 3/8 SAE SS
14	3	3102802	NUT, NYLOCK 3/8-16
15	1	3223302	3/8-16 X 1.25 HEX HEAD BOLT
16	1	7422003	LABEL, MOVING PARTS
17	1	7689801	LABEL, PLSM ASTM WARN
18	1	3223316	3/8-16 X 4.75 HEX HEAD BOLT
19	1	3223314	3/8-16 X 4.25 HEX HEAD BOLT
20	2	3103301	SHAFT COLLAR, 3/4 I.D. ZINC
21	1	8016001	LABEL, PLSM BAR STOP
22	6	3239505	WSH, .500 IN-D ST ZN
23	6	3102801	NUT, NYLOCK 1/2-13 ST ZN
24	6	3239317	1/2-13 X 4.25 UNS HEX FHB G5 ZN
25	6	3102507	WASHER, TYPE A PLAIN
26	3	7760201	ASSY, WEIGHT HORN

PLSM PLATE LOADED SMITH MACHINE LEFT BAR STOP ASSEMBLY - 8013701

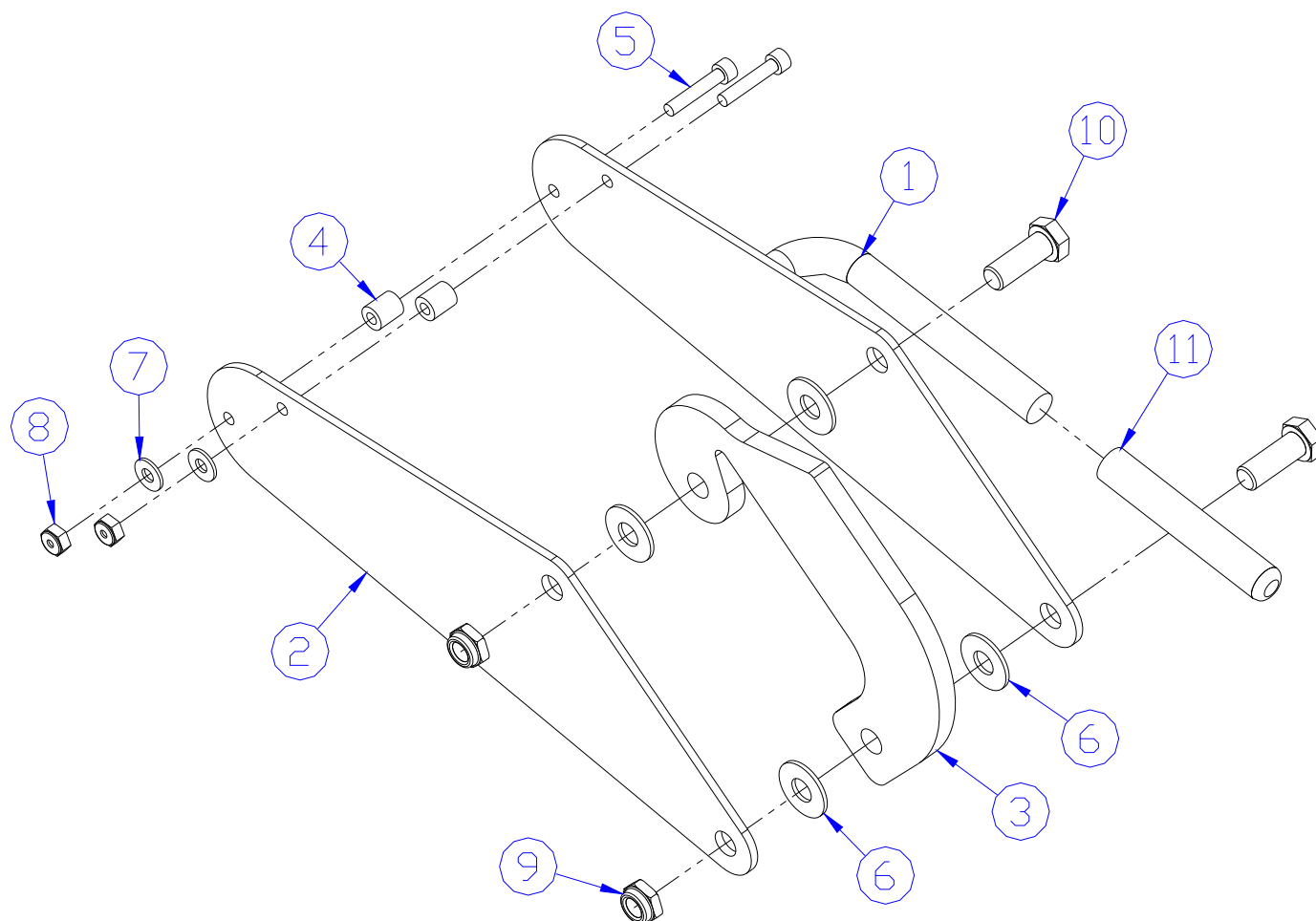

ITEM NO.	QTY.	PART NO.	DESCRIPTION
1	1	8013901	WLDMT, PLSM BAR STOP - LT
2	1	8013501	PLATE, PLSM BAR STOP - SIDE
3	1	8016102	PLATE, PLSM BAR STOP BLK
4	2	7669001	SPACER, NYLON PLSM STOP
5	2	3248204	#10-24 X 1.00 HXS SOC CS G8 BZ
6	4	3227200	WASHER, FLAT NYLON
7	2	3248101	WSH 10 FL-D ST ZN
8	2	3248301	NUT 10 -24 NYLOC D ST ZN
9	2	3102807	NUT, NYLOCK 3/8-16 LOW HT
10	2	3223301	3/8-16 X 1.00 HEX HEAD BOLT
11	1	3238502	CAP, 1/2 X 3

PLSM PLATE LOADED SMITH MACHINE

PLSM CARRIAGE LEFT ASSEMBLY - 7666201

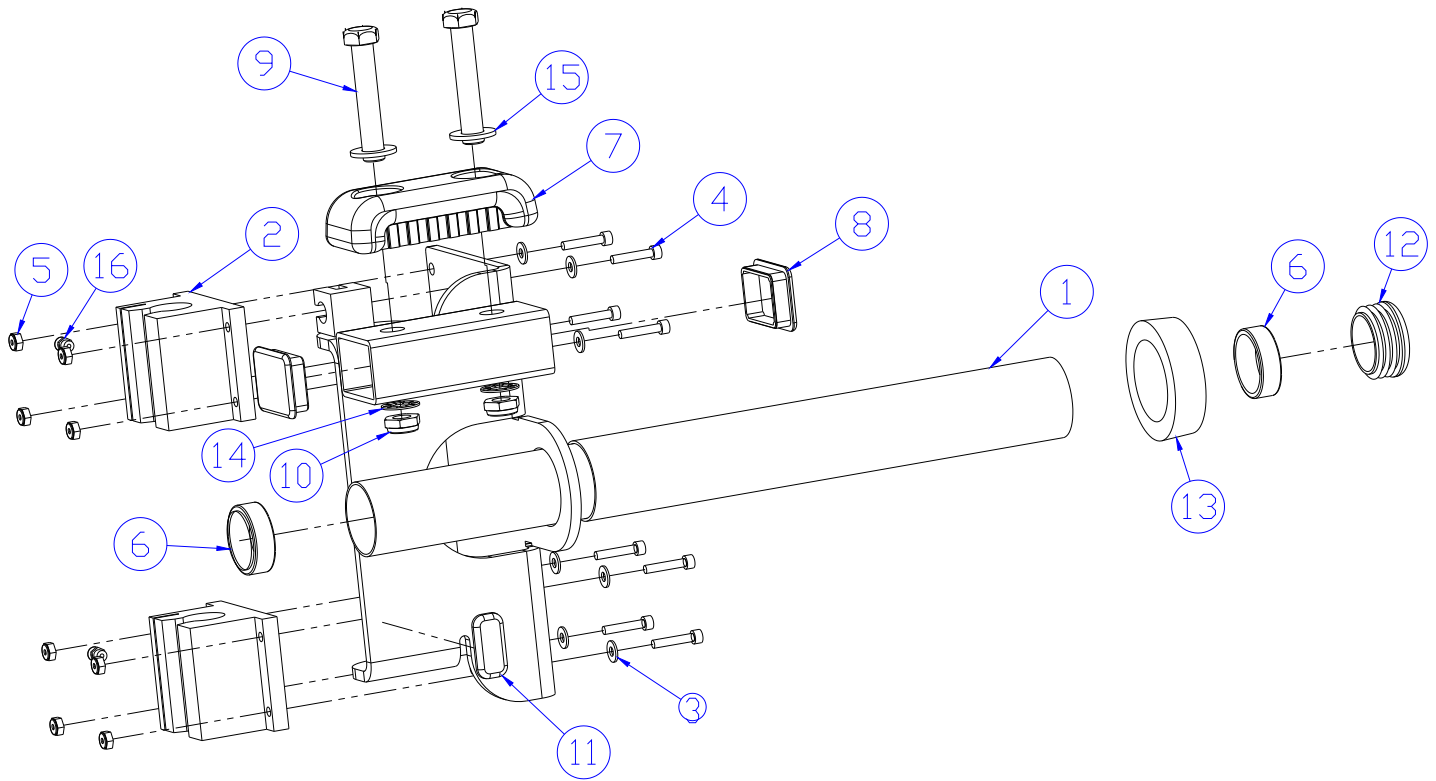

ITEM NO	QTY	PART NO	DESCRIPTION
1	1	7666302	WLDMT, PLSM CARRIAGE LEFT BLK
2	2	3248501	BEARING: BAL 1.000 X 442 SSUPBO 16
3	8	3248101	WSH 10 FL-D ST ZN
4	8	3248204	#10-24 X 1.00 HXS SOC CS G8 BZ
5	8	3248301	NUT 10 -24 NYLOC D ST ZN
6	2	3248601	BEARING: NDLE 1.375ID 1.625OD .5L
7	1	7352001	BUMPER, 2-1/8 X 4-5/8
8	2	7352201	CAP, END 1-1/2 X 2
9	2	3239311	1/2-13 X 2.75 UNS HEX FHB G5 ZN
10	2	3102804	NUT, NYLOCK-JAM 1/2-13 ST ZN
11	1	7570801	Guard, Paint 1.25"x.75"x.25"
12	1	3119302	CAP, END 1 DIA RD 10-12GA
13	1	7671601	MM5 Ring
14	2	3239505	WSH, .500 IN-D ST ZN
15	2	3102507	WASHER, TYPE A PLAIN
16	2	0017-00042-0999	GREASE FITTING

PLSM PLATE LOADED SMITH MACHINE

PLSM BAR ASSEMBLY - 7666401

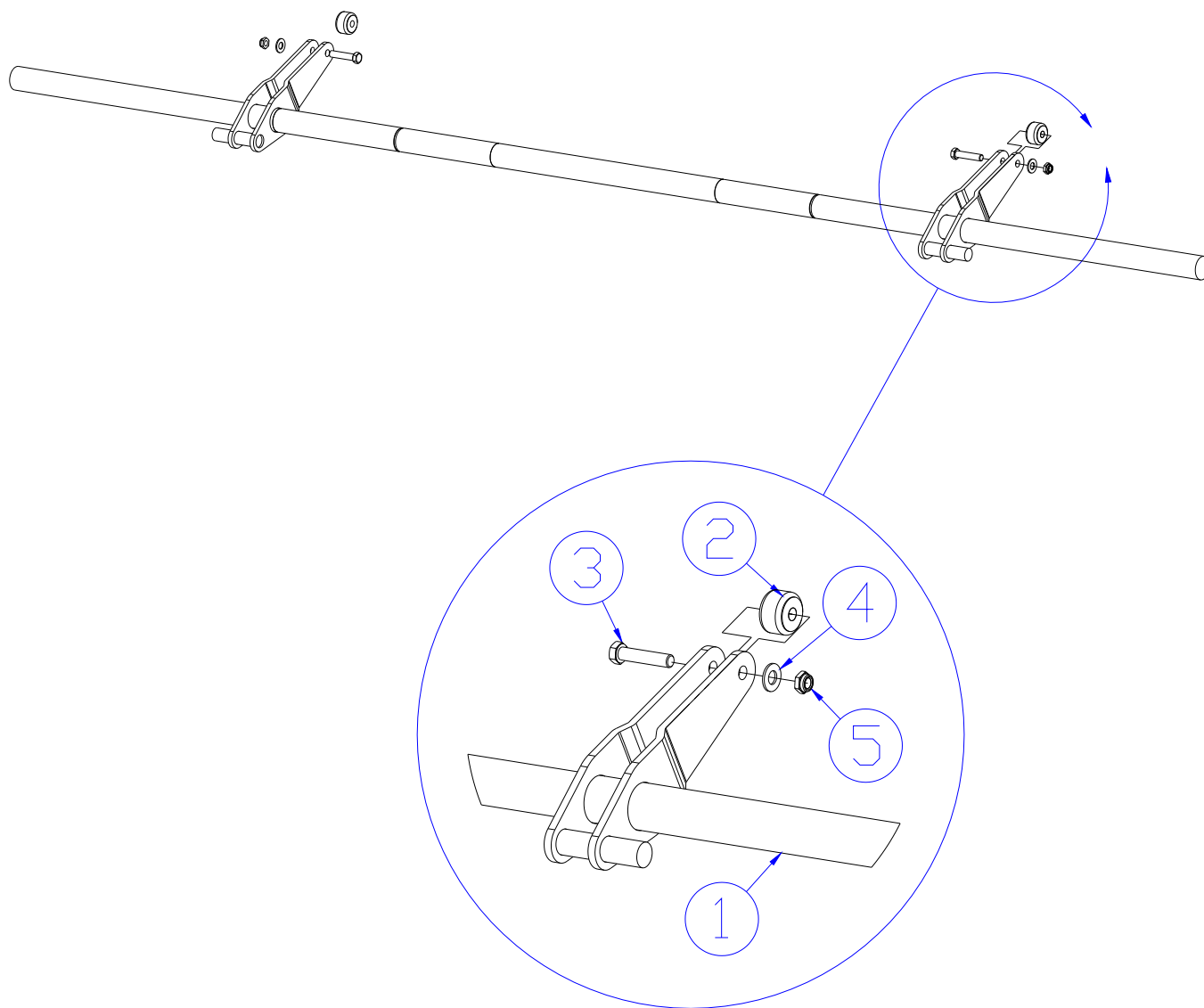

ITEM NO	QTY	PART NO	DESCRIPTION
1	1	7666502	WLDMT, PLSM BAR BLK
2	2	3248401	CAM FOLLOWER TORRINGTON YCR-20
3	2	3223304	3/8-16 X 1.75 HEX HEAD BOLT
4	2	3236601	WASHER, 3/8 SAE SS
5	2	3102807	NUT, NYLOCK 3/8-16 LOW HT

PLSM PLATE LOADED SMITH MACHINE RIGHT SIDE FRAME ASSEMBLY - 7666901

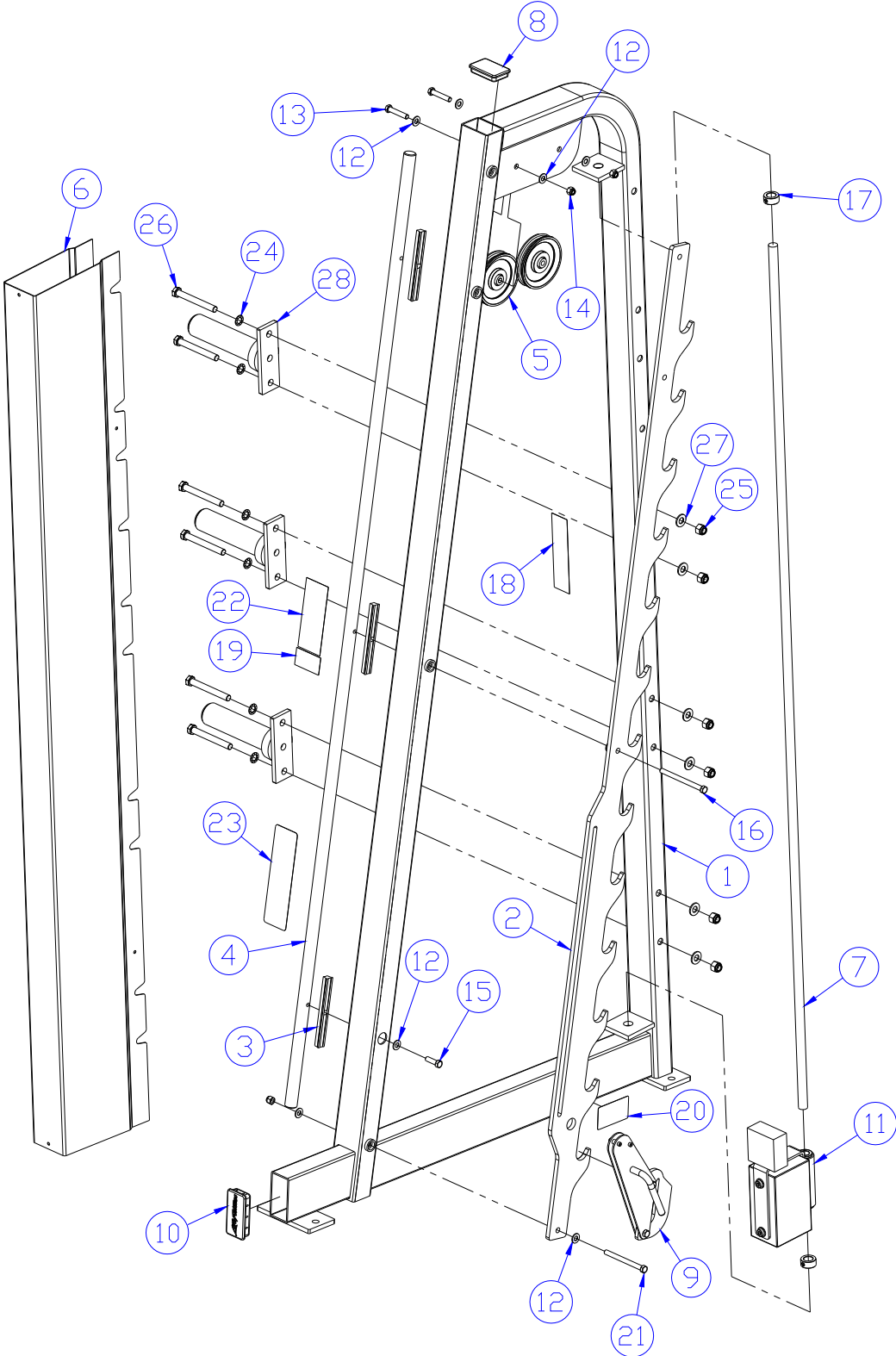

SEE PAGE 10 FOR LEGEND

PLSM PLATE LOADED SMITH MACHINE RIGHT SIDE FRAME ASSEMBLY LEGEND

ITEM NO.	QTY.	PART NO.	DESCRIPTION
1	1	7667001	WLDMT, PLSM SIDE FRAME
2	1	7667601	GUNRACK, PLSM
3	3	7959301	RAIL SUPPORT, PLSM
4	1	7667901	GUIDE ROD, 1" OD X 83
5	2	3237801	PULLEY, 4.5" OD
6	1	7668002	SHIELD, PLSM CW BLK
7	1	7328617	GUIDE ROD, .75 OD SOLID 79.88
8	1	7352301	CAP, END 2 X 3
9	1	8013601	ASSY, PLSM BAR STOP - RT
10	1	7352401	CAP, END 2 X 4
11	1	7668401	ASSY, PLSM COUNTER WEIGHT
12	8	3236601	WASHER, 3/8 SAE SS
13	2	3223305	3/8-16 X 2.50 HEX HEAD BOLT
14	3	3102802	NUT, NYLOCK 3/8-16
15	1	3223302	3/8-16 X 1.25 HEX HEAD BOLT
16	1	3223316	3/8-16 X 4.75 HEX HEAD BOLT
17	2	3103301	SHAFT COLLAR, 3/4 I.D. ZINC
18	1	7422004	LABEL, 2" ASTM WARN
19	1	7422003	LABEL, MOVING PARTS
20	1	7571302	LABEL, SERIAL NUMBER HAMMER
21	1	3223314	3/8-16 X 4.25 HEX HEAD BOLT
22	1	7689801	LABEL, PLSM ASTM WARN
23	1	8016001	LABEL, PLSM BAR STOP
24	6	3239505	WSH, .500 IN-D ST ZN
25	6	3102801	NUT, NYLOCK 1/2-13 ST ZN
26	6	3239317	1/2-13 X 4.25 UNS HEX FHB G5 ZN
27	6	3102507	WASHER, TYPE A PLAIN
28	3	7760201	ASSY, WEIGHT HORN

PLSM PLATE LOADED SMITH MACHINE RIGHT BAR STOP ASSEMBLY - 8013601

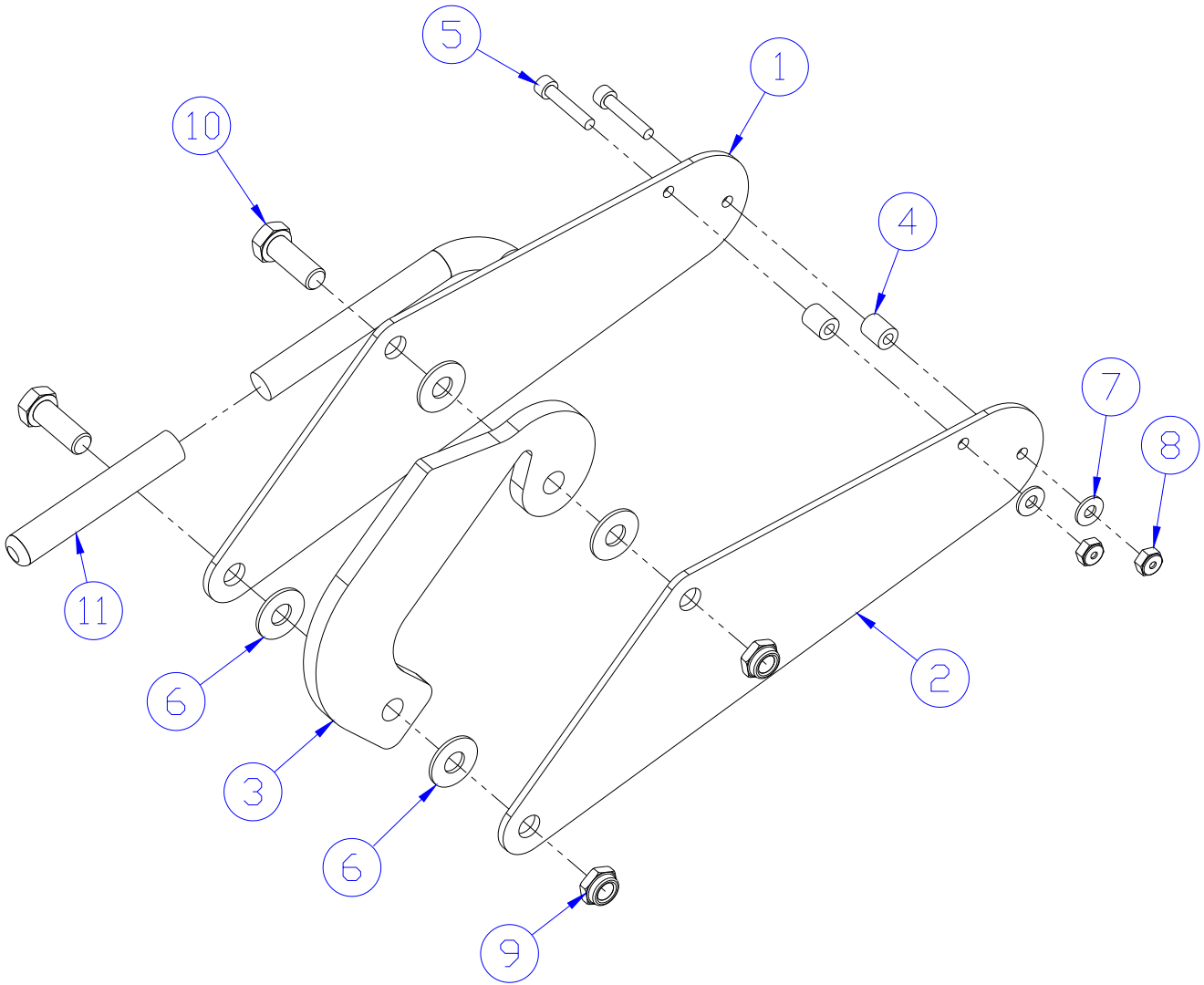

ITEM NO.	QTY.	PART NO.	DESCRIPTION
1	1	8013801	WLDMT, PLSM BAR STOP - RT
2	1	8013501	PLATE, PLSM BAR STOP - SIDE
3	1	8016102	PLATE, PLSM BAR STOP BLK
4	2	7669001	SPACER, NYLON PLSM STOP
5	2	3248204	#10-24 X 1.00 HXS SOC CS G8 BZ
6	4	3227200	WASHER, FLAT NYLON
7	2	3248101	WSH 10 FL-D ST ZN
8	2	3248301	NUT 10 -24 NYLOC D ST ZN
9	2	3102807	NUT, NYLOCK 3/8-16 LOW HT
10	2	3223301	3/8-16 X 1.00 HEX HEAD BOLT
11	1	3238502	CAP, 1/2 X 3

PLSM PLATE LOADED SMITH MACHINE

PLSM CARRIAGE RIGHT ASSEMBLY - 7665601

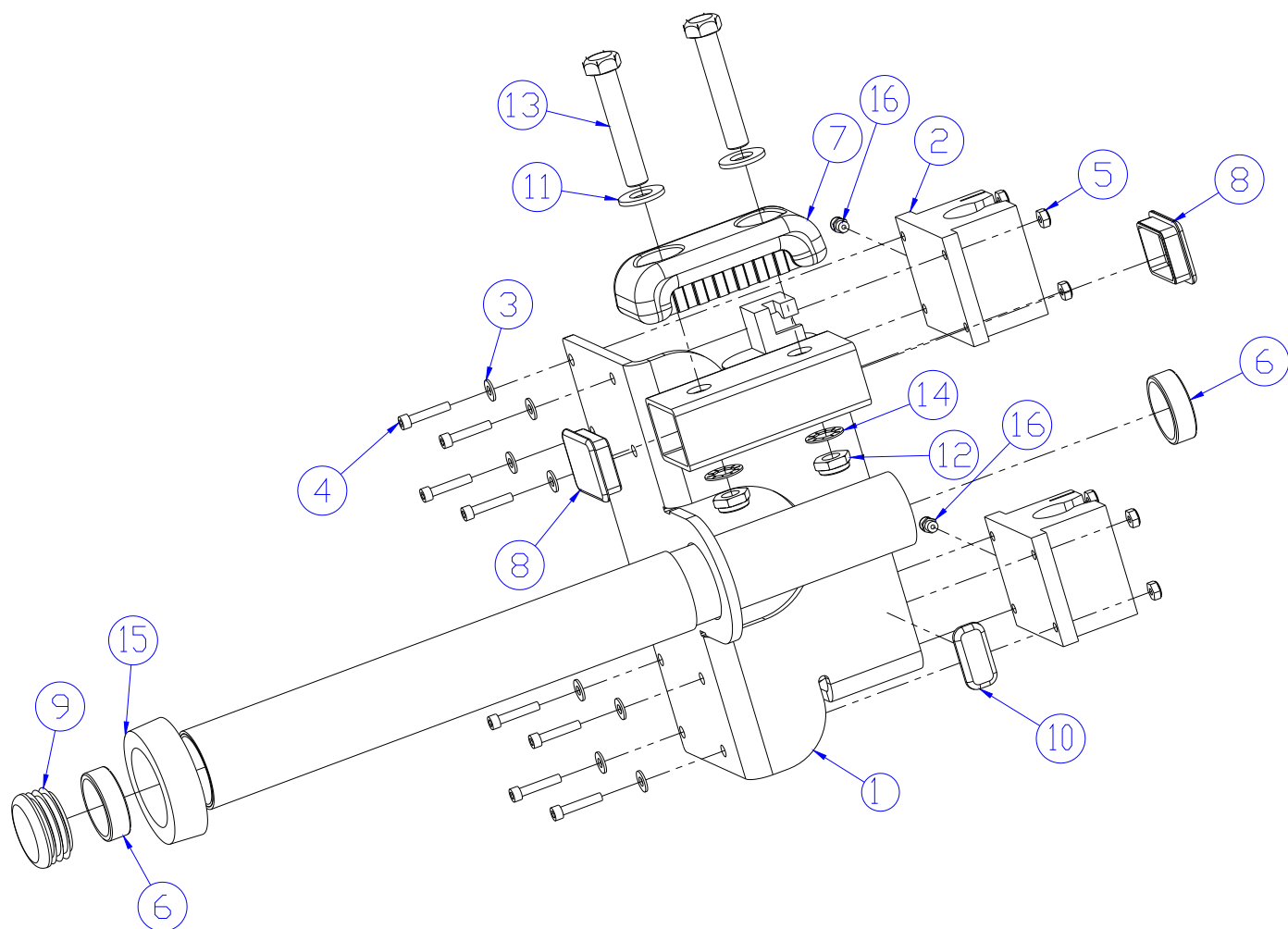

ITEM NO	QTY	PART NO	DESCRIPTION
1	1	7665702	WLDMT, PLSM CARRIAGE RIGHT BLK
2	2	3248501	BEARING: BAL 1.000 X 442 SSUPBO 16
3	8	3248101	WSH 10 FL-D ST ZN
4	8	3248204	#10-24 X 1.00 HXS SOC CS G8 BZ
5	8	3248301	NUT 10 -24 NYLOC D ST ZN
6	2	3248601	BEARING: NDLE 1.375ID 1.625OD .5L
7	1	7352001	BUMPER, 2-1/8 X 4-5/8
8	2	7352201	CAP, END 1-1/2 X 2
9	1	3119302	CAP, END 1 DIA RD 10-12GA
10	1	7570801	Guard, Paint 1.25"x.75"x.25"
11	2	3102507	WASHER, TYPE A PLAIN
12	2	3102804	NUT, NYLOCK-JAM 1/2-13 ST ZN
13	2	3239311	1/2-13 X 2.75 UNS HEX FHB G5 ZN
14	2	3239505	WSH, .500 IN-D ST ZN
15	1	7671601	MM5 Ring
16	2	0017-00042-0999	GREASE FITTING

PLSM PLATE LOADED SMITH MACHINE PLSM COUNTER WEIGHT ASSEMBLY - 7668401

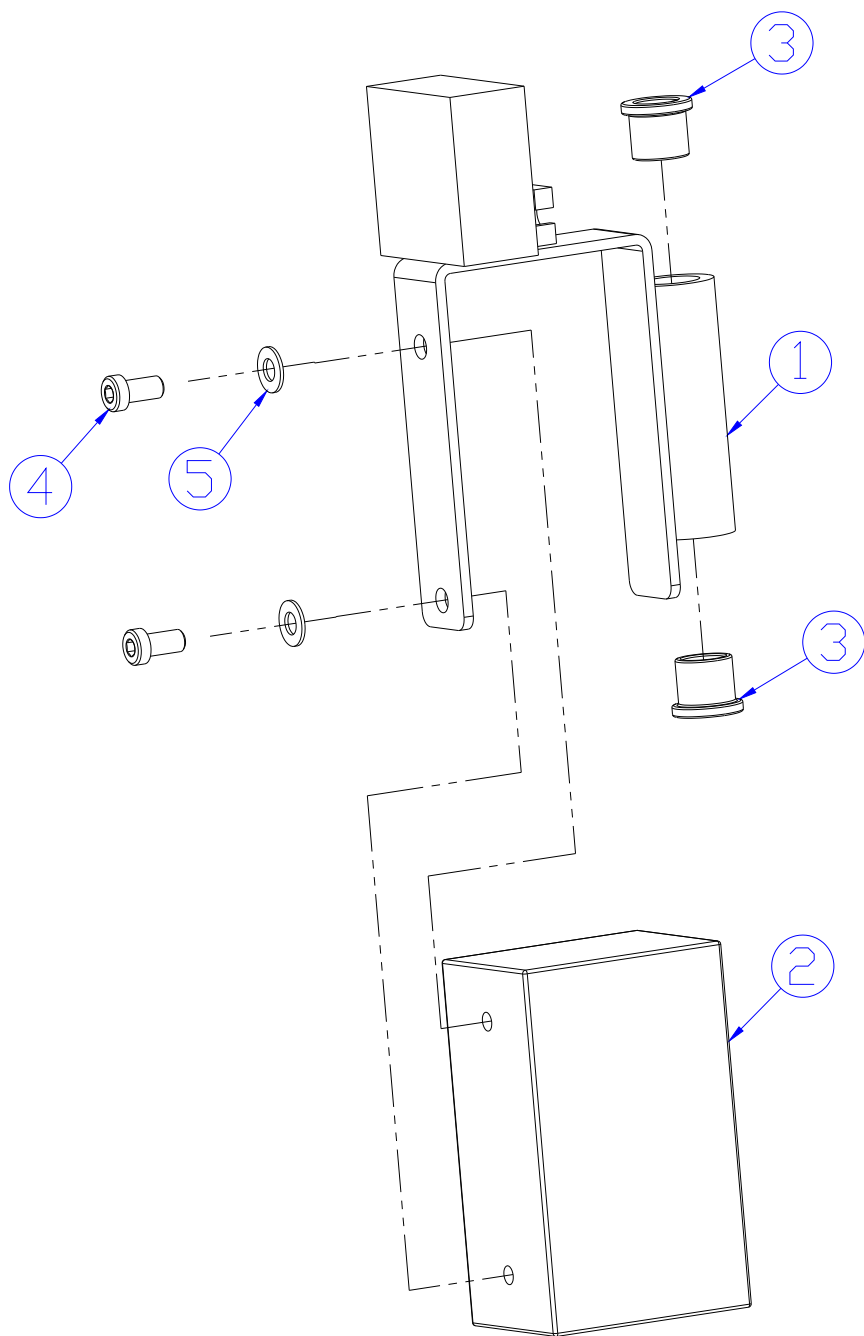

ITEM NO	QTY	PART NO	DESCRIPTION
1	1	7668502	WLDMT, PLSM C-WEIGHT BLK
2	1	7354595	WEIGHT, COUNTER MED SHADOW GRAY
3	2	3104905	.75" ID 1.00" OD BRONZE BUSHING
4	2	3236201	SCREW, M10 X1.5 20MM
5	2	3236601	WASHER, 3/8 SAE SS

PLSM PLATE LOADED SMITH MACHINE PLSM WEIGHT HORN ASSEMBLY - 7760201

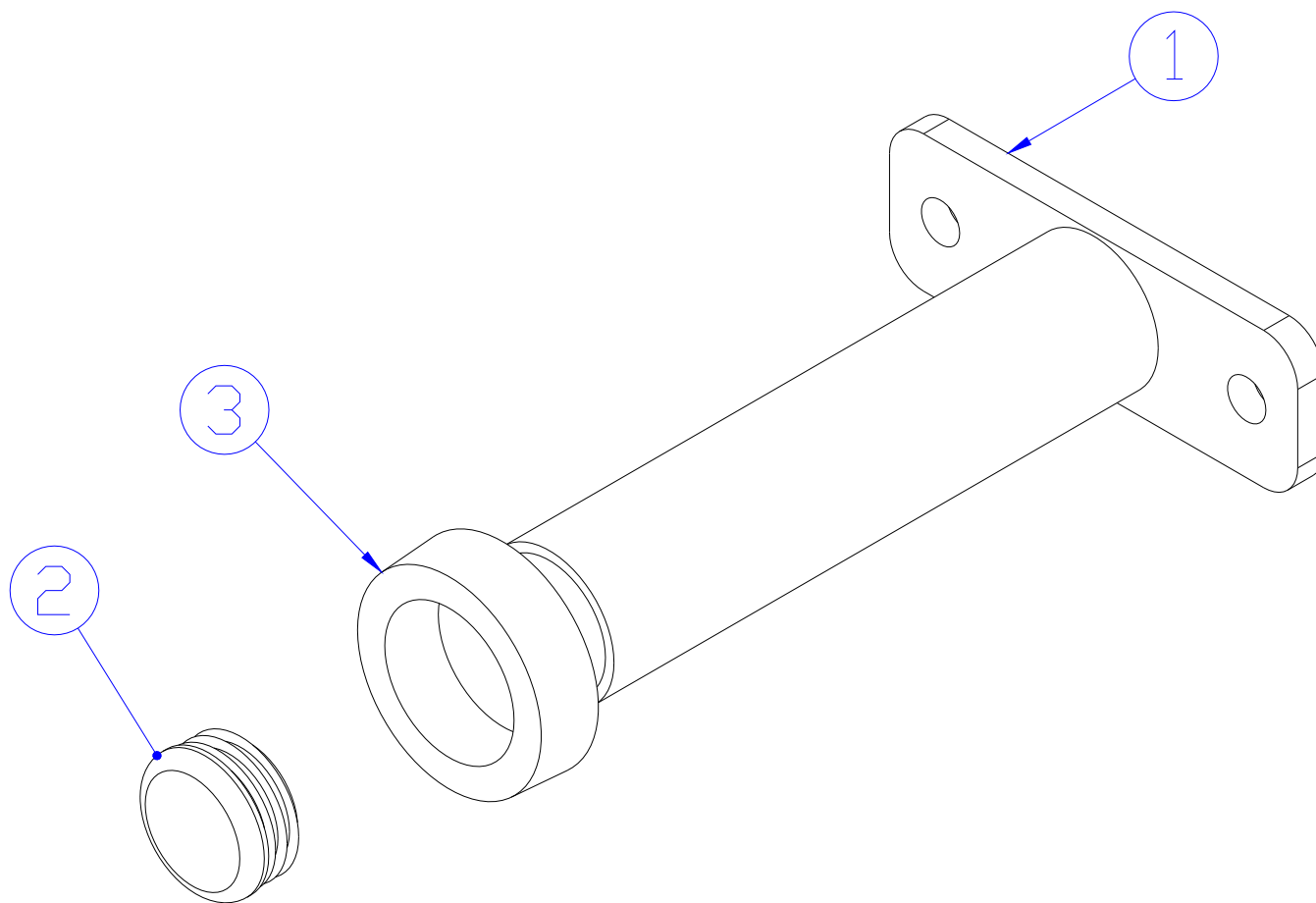

ITEM NO	QTY	PART NO	DESCRIPTION
1	1	7662701	WEIGHT HORN
2	1	3119302	CAP, END 1 DIA RD 10-12GA
3	1	7671601	MM5 Ring

PLSM PLATE LOADED SMITH MACHINE IMAGE (Shown with optional bench)

