

Lifestyler®

DT 10000

SEARS

Model No. 831.288262

Serial No. _____

Write the serial number in the space above for future reference.

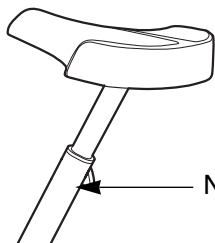

Serial
Number
Decal

EXERCISE
EQUIPMENT

QUESTIONS

HELPLINE!

1-800-736-6879



Patent Pending

CAUTION

Read all precautions and instructions in this manual before using this equipment. Keep this manual for future reference.

USER'S MANUAL

TABLE OF CONTENTS

IMPORTANT PRECAUTIONS	2
BEFORE YOU BEGIN	3
ASSEMBLY	4
HOW TO USE THE LIFESTYLER® DT1000	6
MAINTENANCE AND TROUBLE-SHOOTING	8
CONDITIONING GUIDELINES	9
PART LIST	10
EXPLODED DRAWING	11
ORDERING REPLACEMENT PARTS	Back Cover
FULL 90 DAY WARRANTY	Back Cover

IMPORTANT PRECAUTIONS

WARNING: To reduce the risk of serious injury, read the following important precautions before using the LIFESTYLER® DT1000.

1. It is the responsibility of the owner to ensure that all users of the DT1000 are adequately informed of all warnings and precautions.
2. Read all instructions in this manual before using the DT1000. Use the DT1000 only as described.
3. Place the DT1000 on a level surface. Cover the floor beneath the DT1000 to protect the floor or carpet.
4. Inspect and tighten all parts regularly. Make sure that the chain is properly adjusted (see MAINTENANCE AND TROUBLE-SHOOTING on page 8). Replace any worn parts immediately.
5. Keep children under age 12 and pets away from the DT1000 at all times.
6. The DT1000 should not be used by persons weighing more than 250 pounds.
7. Keep hands and feet away from the link arms and other moving parts.
8. Do not wear loose clothing that could become caught on the DT1000. Always wear athletic shoes for foot protection.
9. When adjusting the seat, insert the seat knob through one of the holes in the seat post (see the drawing on page 3). Do not insert the seat knob under the seat post.
10. If you feel faint, dizzy, or short of breath while exercising, stop immediately and begin cooling down.
11. The DT1000 is intended for home use only. Do not use the DT1000 in any commercial, rental, or institutional setting.
12. The decal shown below has been placed on the DT1000. If the decal is missing, or if it is not legible, please call our toll-free HELPLINE to order a free replacement decal (see the back cover of this manual). Apply the decal in the location shown.

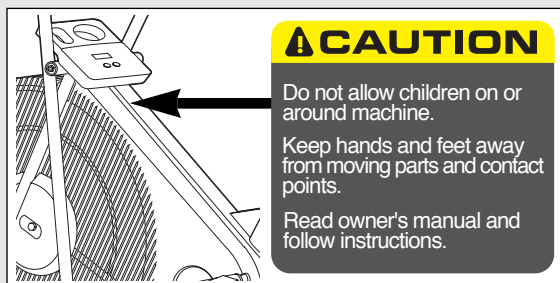

WARNING: Before beginning this or any exercise program, consult your physician. This is especially important for persons over the age of 35 or persons with pre-existing health problems. Read all instructions before using. SEARS assumes no responsibility for personal injury or property damage sustained by or through the use of this product.

BEFORE YOU BEGIN

Thank you for selecting the innovative LIFESTYLER® DT1000. The DT1000 blends advanced engineering with contemporary styling to provide you with a low-impact, total body workout in the convenience and privacy of your own home.

For your benefit, read this manual carefully before you use the LIFESTYLER® DT1000. If you have additional questions, please call our toll-free HELPLINE at 1-800-736-6879, Monday through Saturday, 7 a.m.

until 7 p.m. Central Time (excluding holidays). To help us assist you, please note the product model number and serial number before calling. The model number is 831.288262. The serial number can be found on a decal attached to the DT1000 (see the front cover of this manual for the location of the decal).

Before reading further, please review the drawing below and familiarize yourself with the parts that are labeled.

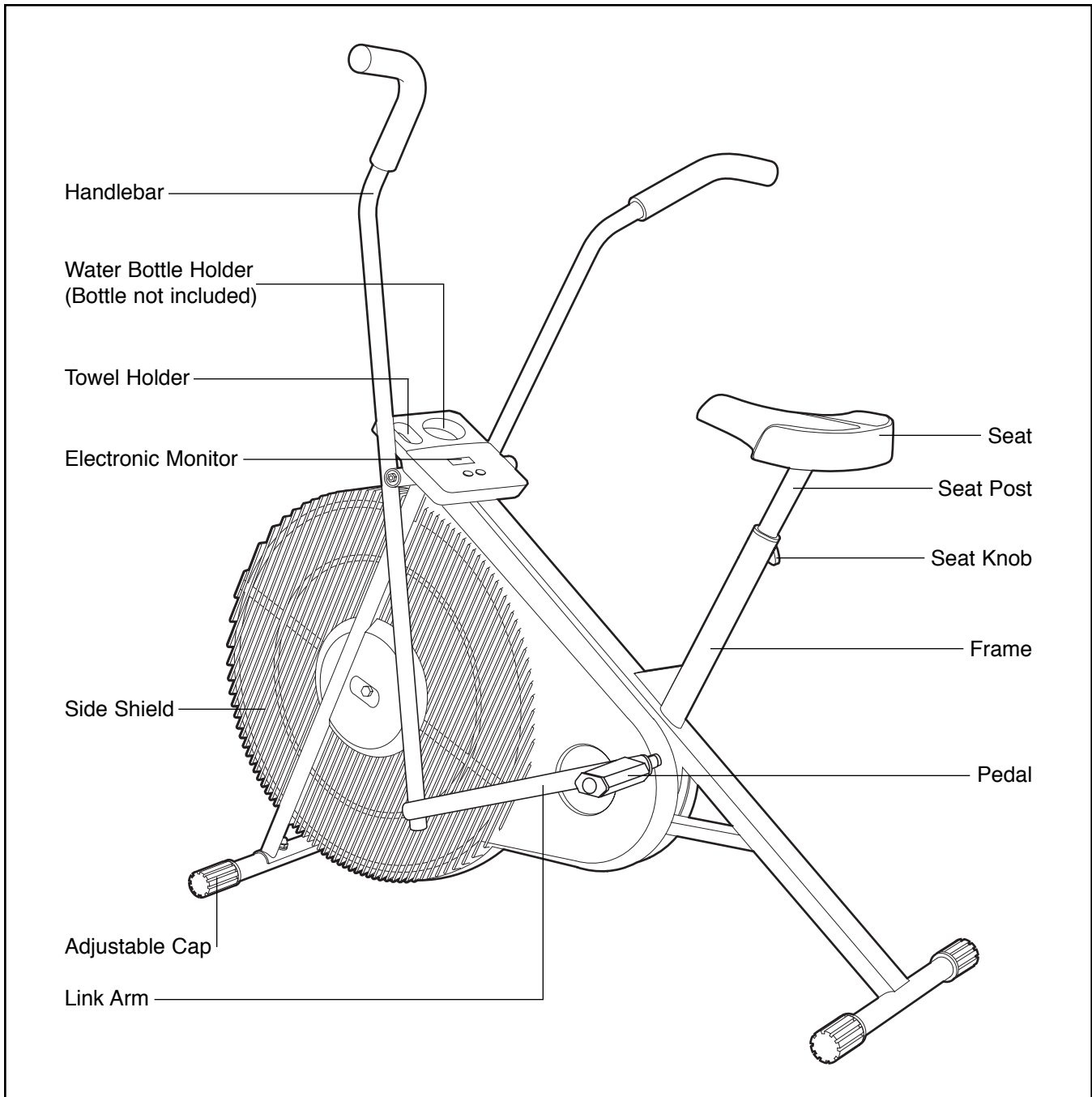

ASSEMBLY

Assembly requires two people. Place all parts of the LIFESTYLER® DT1000 in a cleared area and remove the packing materials. Do not dispose of the packing materials until assembly is completed. Read through all steps before beginning. During assembly, make sure that all parts are oriented as shown in the drawings.

Assembly requires the included tool and grease packet, an adjustable wrench , **a rubber mallet** , **and a phillips screwdriver** .

1. Insert the end of the Rear Stabilizer (34) into the Frame (46). Attach the Rear Stabilizer to the Frame with four M5 x 12mm Screws (56).

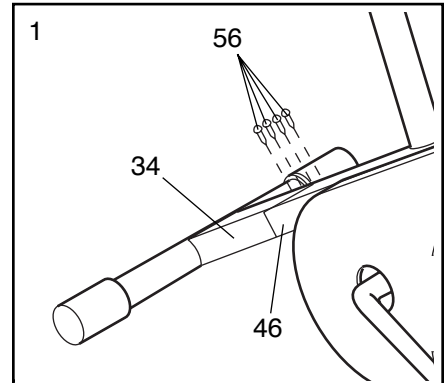

2. Turn the Front Stabilizer (20) so the indented holes are facing the floor. Attach the Front Stabilizer to the Frame (46) with two M8 x 48mm Carriage Bolts (57), two M8 Washers (43), and two Acorn Nuts (12).

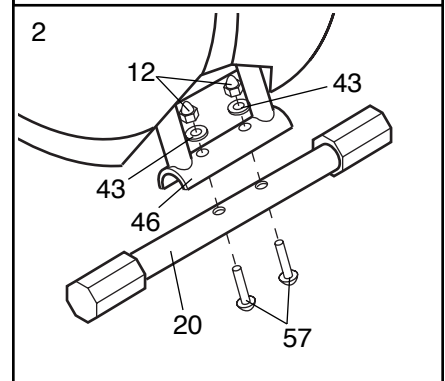

3. Remove the three 8mm Locknuts (36) from the underside of the Seat (40). Attach the Seat to the top of the Seat Post (41) with the three Locknuts.

Insert the Seat Post (41) into the Frame (46). Align one of the holes in the Seat Post with the hole in the Frame. Insert the Seat Knob (45) into the Frame and the Seat Post, and tighten the Seat Knob into the Frame. **Make sure to insert the Seat Knob through one of the holes in the Seat Post; do not insert the Seat Knob under the Seat Post.**

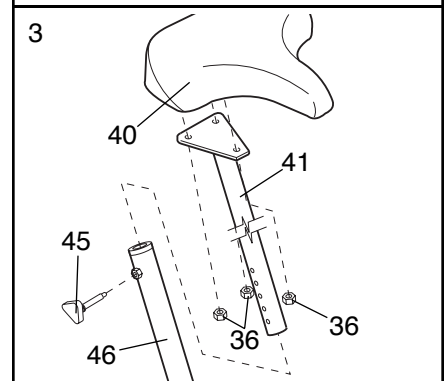

4. Apply a small amount of grease to the Pivot Shaft (17). Slide the Pivot Shaft into the Frame (46) and center it. Slide the Left Handlebar (10) onto the left end of the Pivot Shaft. Slide the Right Handlebar (not shown) onto the right end of the Pivot Shaft. Attach an M8 Washer (43) and an 8mm Locknut (36) to each end of the Pivot Shaft.

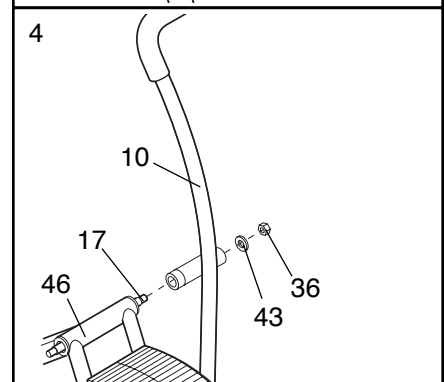

- The Electronic Monitor (19) requires two “AA” batteries (not included). Alkaline batteries are recommended. Locate the battery compartment on the back of the Monitor. Insert two batteries into the Monitor. **Make sure that the negative ends of the batteries (marked “-”) are touching the springs in the Monitor.** Close the battery cover.

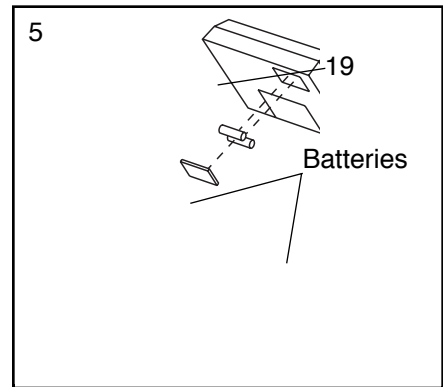

- Thread the wire on the Electronic Monitor (19) through the hole in the middle of the Monitor Bracket (61). Attach the Electronic Monitor (19) to the Monitor Bracket with four Monitor Screws (59).

Connect the Sensor Wire (47) to the wire on the Electronic Monitor (19). Attach the Monitor Bracket (61) to the Frame (46) using two M4 x 12.5mm Tek Screws (60). **Make sure that the Sensor Wire is not pinched between the Monitor and the Frame.**

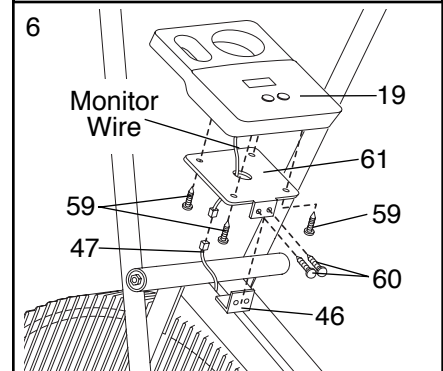

- Apply a small amount of grease to the bolt welded in the Right Handlebar (38). Connect a Link Arm (26) to the lower end of the Right Handlebar with an M8 Washer (43), a Brass Handlebar Bushing (27), another M8 Washer (43), and an 8mm Locknut (36) as shown.

Attach the other Link Arm to the Left Handlebar in the same manner (not shown).

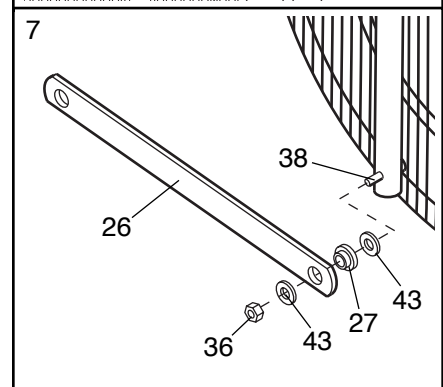

- Note: Apply a small amount of grease to all of the small parts assembled in this step. Slide a 13mm Washer (23) onto the indicated end of a Pedal Axle (24). Insert the Pedal Axle into the right Link Arm (26). Slide a Steel Link Arm Bushing (32), a 13mm Washer (23), and a Pedal Spacer (33) onto the Pedal Axle. Firmly tighten the Pedal Axle clockwise into the right arm of the Crank (39). Tighten a 1/2” Locknut (22) onto the Pedal Axle.

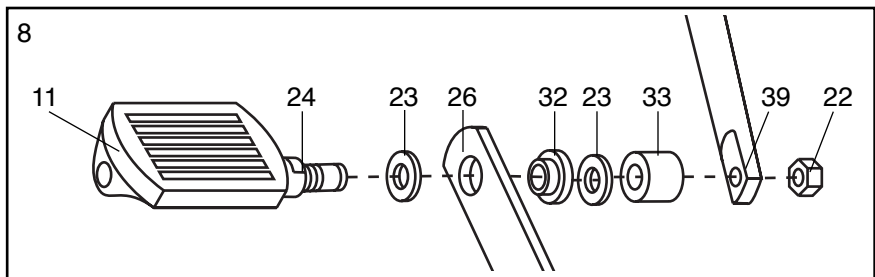

Attach the other Pedal to the left arm of the Crank (not shown) in the same manner.

- Make sure that all parts of the exercise bike are properly tightened.**

HOW TO USE THE LIFESTYLER® DT1000

SEAT ADJUSTMENT

As you pedal, there should be a slight bend in your knees when the pedals are at the lowest position. To adjust the seat, first hold the seat and unscrew the seat knob. Align one of the holes in the seat post with the hole in the frame. Insert the seat knob into the frame and the seat post, and tighten the seat knob through the frame. **Make sure to insert the seat knob through one of the holes in the seat post; do not insert the seat knob under the seat post.**

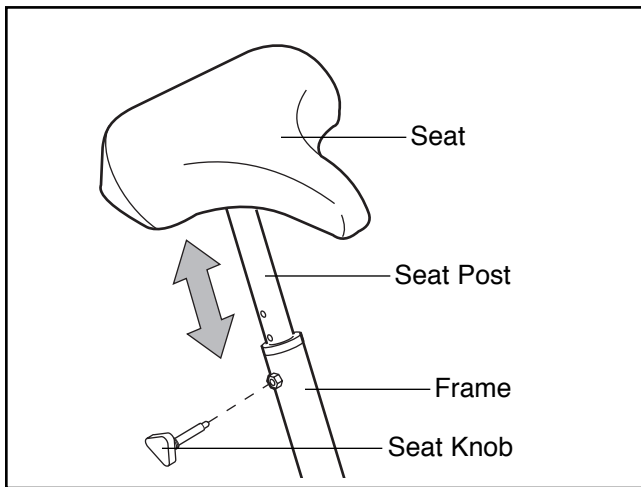

LEVELING THE LIFESTYLER® DT1000

If the exercise bike does not rest evenly on the floor, the problem may be corrected with the adjustable caps on the front stabilizer. Rotate one or both caps until the exercise bike rests evenly on the floor.

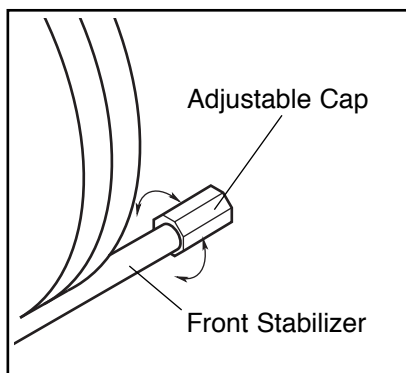

DESCRIPTION OF THE ELECTRONIC MONITOR

The electronic monitor features five modes that provide instant exercise feedback during your workouts. The modes are described below.

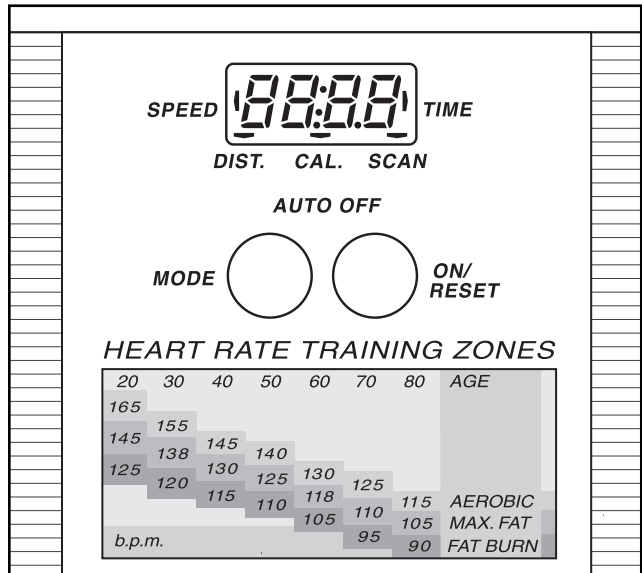

- Speed—Displays your pedaling speed, in miles per hour.
- Time—Displays the length of time you have exercised. Note: If you stop pedaling for ten seconds or longer, the time mode will pause until you resume.
- Distance—Displays the total distance you have pedaled, in miles.
- Calorie—Displays the approximate number of Calories you have burned.
- Scan—Displays the speed, time, distance, and calorie modes, for 5 seconds each, in a repeating cycle.

BATTERY INSTALLATION

Before the electronic monitor can be operated, two “AA” batteries must be installed. If you have not installed batteries, see assembly step 5 on page 5.

HOW TO OPERATE THE ELECTRONIC MONITOR

1. To turn on the power, press the on/reset button or simply begin pedaling. When the power is turned on, the entire display will appear for two seconds. The electronic monitor will then be ready for operation.

2. Select one of the five modes:

Scan mode—When the power is turned on, the scan mode will automatically be selected. One mode arrow

will show that the scan mode is selected, and a flashing mode arrow will show which mode is currently

displayed. Note: If a different mode is selected, you can select the scan mode again by repeatedly pressing the mode button.

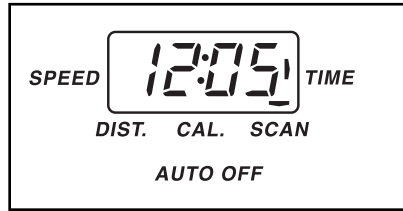

Speed, time, distance or calorie mode—To select one of these modes for continuous display, press the mode button repeatedly.

The mode arrows will show which mode is selected.

(Make sure that the scan mode is not selected.)

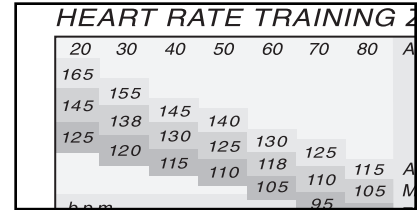

3. To reset the display, press the on/reset button.

4. To turn off the power, simply wait for about four minutes. **Note: The monitor has an “auto-off” feature. If the pedals are not moved and the monitor buttons are not pressed for four minutes, the power will turn off automatically in order to conserve the batteries.**

MAINTENANCE AND TROUBLE-SHOOTING

Inspect and tighten all parts of the LIFESTYLER® DT1000 regularly. Replace worn parts immediately.

The DT1000 can be cleaned with a soft, damp cloth. Keep liquid away from the electronic monitor. Keep the monitor out of direct sunlight or the display may be damaged. Remove the batteries when storing the DT1000.

ELECTRONIC MONITOR TROUBLE-SHOOTING

If the electronic monitor does not function properly, the batteries should be replaced. See assembly step 5 on page 5 for instructions. In addition, make sure that the sensor wire is connected to the wire on the monitor. See assembly step 6 on page 5.

If the electronic monitor displays incorrect information, the reed switch should be checked. First, remove the pedal and the side shield from one side of the exercise bike.

Next, refer to the drawing at the right and locate the reed switch. Turn the sprocket until the magnet on the sprocket is as close

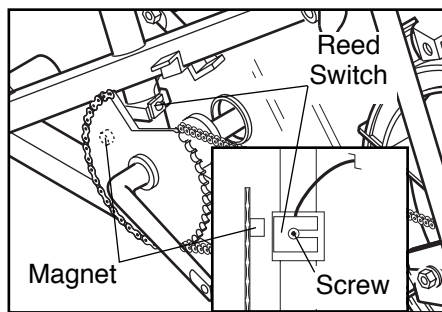

as possible to the reed switch. Loosen the screw in the reed switch, move the reed switch slightly closer to the magnet, and tighten the screw. **Make sure that the magnet will not hit the reed switch when the sprocket turns.** Repeat until the monitor displays correct information.

HOW TO TIGHTEN THE PEDALS

If the pedals become loose, refer to assembly step 8 on page 5. Tighten the pedal axles into the arms of the crank. Tighten the 1/2" locknuts on the pedal axles.

HOW TO ADJUST THE CHAIN

The exercise bike features a precision chain that must be kept properly lubricated. Apply a few drops of light multi-purpose oil to the chain every three months.

In addition, the chain must be kept properly adjusted. If the chain is too tight, the bearings may be damaged; if the chain is too loose, the fan may be damaged. If the chain causes excessive noise or slips as you pedal, check the chain in the following manner:

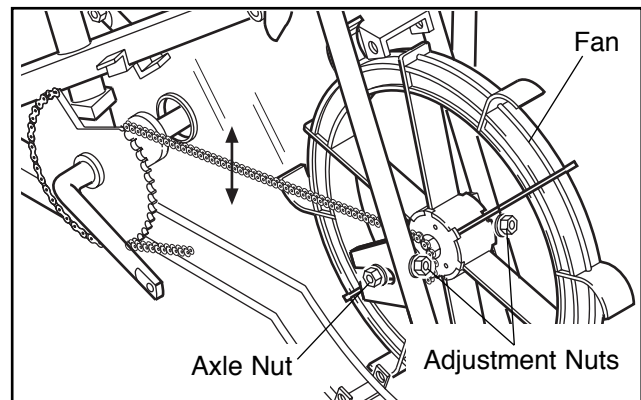

1. Remove the fan guards from the front of the exercise bike. Remove the pedal and the side shield from one side of the exercise bike.
2. Press down on the center of the chain. **There should be between 1/4" and 1" of vertical movement in the center of the chain.** If the chain is properly adjusted, reattach the side shield, pedal, and fan guards. If the chain needs to be adjusted, see step 3.
3. Loosen both axle nuts. To tighten the chain, turn the adjustment nuts clockwise; to loosen the chain, turn the adjustment nuts counterclockwise. Make sure that the fan is straight and tighten the axle nuts. Reattach the side shield, pedal, and fan guards.

CONDITIONING GUIDELINES

The following general guidelines will help you to plan your exercise program. Remember that proper nutrition and adequate rest are essential for successful results.

WARNING: Before beginning this or any exercise program, consult your physician. This is especially important for individuals over the age of 35 or individuals with pre-existing health problems.

EXERCISE INTENSITY

Whether your goal is to burn fat or strengthen your cardiovascular system, the key to achieving the desired results is to exercise with the proper intensity. The proper intensity level can be found by using your heart rate as a guide. The chart below shows recommended heart rates for fat burning, maximum fat burning, and cardiovascular (aerobic) exercise.

20	30	40	50	60	70	80	AGE
165							
145	155						
125	138	145	140				
	120	130	125	130	125		
		115	110	118	110	115	AEROBIC
				105	110	105	MAX. FAT
b.p.m.					95	90	FAT BURN

To find the proper heart rate for you, first find your age near the top of the chart (ages are rounded off to the nearest ten years). Next, find the three numbers below your age. The three numbers are your "training zone." The lowest number is the recommended heart rate for fat burning; the middle number is the recommended heart rate for maximum fat burning; the highest number is the recommended heart rate for aerobic exercise.

Fat Burning

To burn fat effectively, you must exercise at a relatively low intensity level for a sustained period of time. During the first few minutes of exercise, your body uses easily accessible carbohydrate calories for energy. Only after the first few minutes of exercise does your body begin to use stored fat calories for energy. If

your goal is to burn fat, adjust your pace until your heart rate is near the lowest number in your training zone as you exercise.

For maximum fat burning, adjust your pace until your heart rate is near the middle number in your training zone as you exercise.

Aerobic Exercise

If your goal is to strengthen your cardiovascular system, your exercise must be "aerobic." Aerobic exercise is activity that requires large amounts of oxygen for prolonged periods of time. This increases the demand on the heart to pump blood to the muscles, and on the lungs to oxygenate the blood. For aerobic exercise, adjust your pace until your heart rate is near the highest number in your training zone as you exercise.

HOW TO MEASURE YOUR HEART RATE

To measure your heart rate, first exercise for at least four minutes. Then, stop exercising and place two fingers on your wrist as shown.

Take a six-second heart-beat count, and multiply the result by 10 to find your heart rate. For example, if your six-second

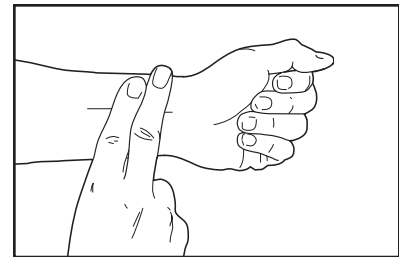

heartbeat count is 14, your heart rate is 140 beats per minute. (A six-second count is used because your heart rate will drop rapidly when you stop exercising.) Adjust the intensity of your exercise until your heart rate is at the desired level.

WORKOUT GUIDELINES

Each workout should include three important parts: a warm-up, training zone exercise, and a cool-down.

A Warm-up

Start each workout with 5 to 10 minutes of stretching and light exercise. A proper warm-up increases your body temperature, heart rate, and circulation in preparation for strenuous exercise.

Training Zone Exercise

After warming up, increase the intensity of your exercise until your heart rate is in your training zone for 20 to 30 minutes. (During the first few weeks of your exercise program, do not keep your heart rate in your training zone for longer than 20 minutes.)

A Cool-down

Finish each workout with 5 to 10 minutes of stretching. This will increase the flexibility of your muscles and will help to prevent post-exercise problems.

Exercise Frequency

To maintain or improve your condition, complete three workouts each week, with at least one day of rest between workouts. After a few months of regular exercise, you may complete up to five workouts each week if desired.

The key to success is to make exercise a regular and enjoyable part of your everyday life.

PART LIST—Model No. 831.288262

R0800A

Key No.	Qty.	Description	Key No.	Qty.	Description
1	2	Axle Nut	33	2	Pedal Spacer
2	1	Fan Plate	34	1	Rear Stabilizer
3	1	Short Spacer	35	2	Stabilizer Cap
4	1	Fan Sprocket	36	7	8mm Locknut
5	1	Fan Axle Shaft	37	2	Fan Guard
6	3	Flange Bushing	38	1	Right Handlebar
7	1	Fan Assembly	39	1	Crank/Sprocket Assembly
8	4	Handlebar Cap	40	1	Seat
9	2	Foam Grip	41	1	Seat Post
10	1	Left Handlebar	42	2	Pedal Locknut
11	2	Pedal	43	8	M8 Washer
12	2	Acorn Nut	44	1	Seat Post Bushing
13	2	8mm x 16mm Washer	45	1	Seat Knob
14	2	Outer Pivot Bushing	46	1	Frame
15	1	Left Side Shield	47	1	Reed Switch/Sensor Wire
16	2	Adjustable Cap	48	1	Magnet
17	1	Pivot Shaft	49	4	Fan Guard Clip
18	2	Pedal Cap	50	1	Long Spacer
19	1	Electronic Monitor	51	1	Right Side Shield
20	1	Front Stabilizer	52	1	Chain
21	3	M4 x 25mm Screw	53	1	M10 Flat Washer
22	2	1/2" Locknut	54	1	Fan Guard Bracket
23	4	13mm Washer	55	10	Self-tapping Screw
24	2	Pedal Axle	56	6	M5 x 12mm Washer Screw
25	2	Fan Nut	57	2	M8 x 48mm Carriage Bolt
26	2	Link Arm	58	1	Reed Switch Screw
27	2	Brass Handlebar Bushing	59	4	Monitor Screw
28	4	Inner Pivot Bushing	60	2	M4 x 12.5mm Tek Screw
29	2	Adjustment Nut	61	1	Monitor Bracket
30	2	M6 Washer	62	1	Crank/Sprocket
31	2	Adjustment Bolt	#	1	User's Manual
32	2	Link Arm Bushing	#	1	Caution Decal

Note: “#” indicates a non-illustrated part. Specifications are subject to change without notice. See the back cover of this manual for information about ordering replacement parts.

EXPLODED DRAWING—Model No. 831.288262

R0800A

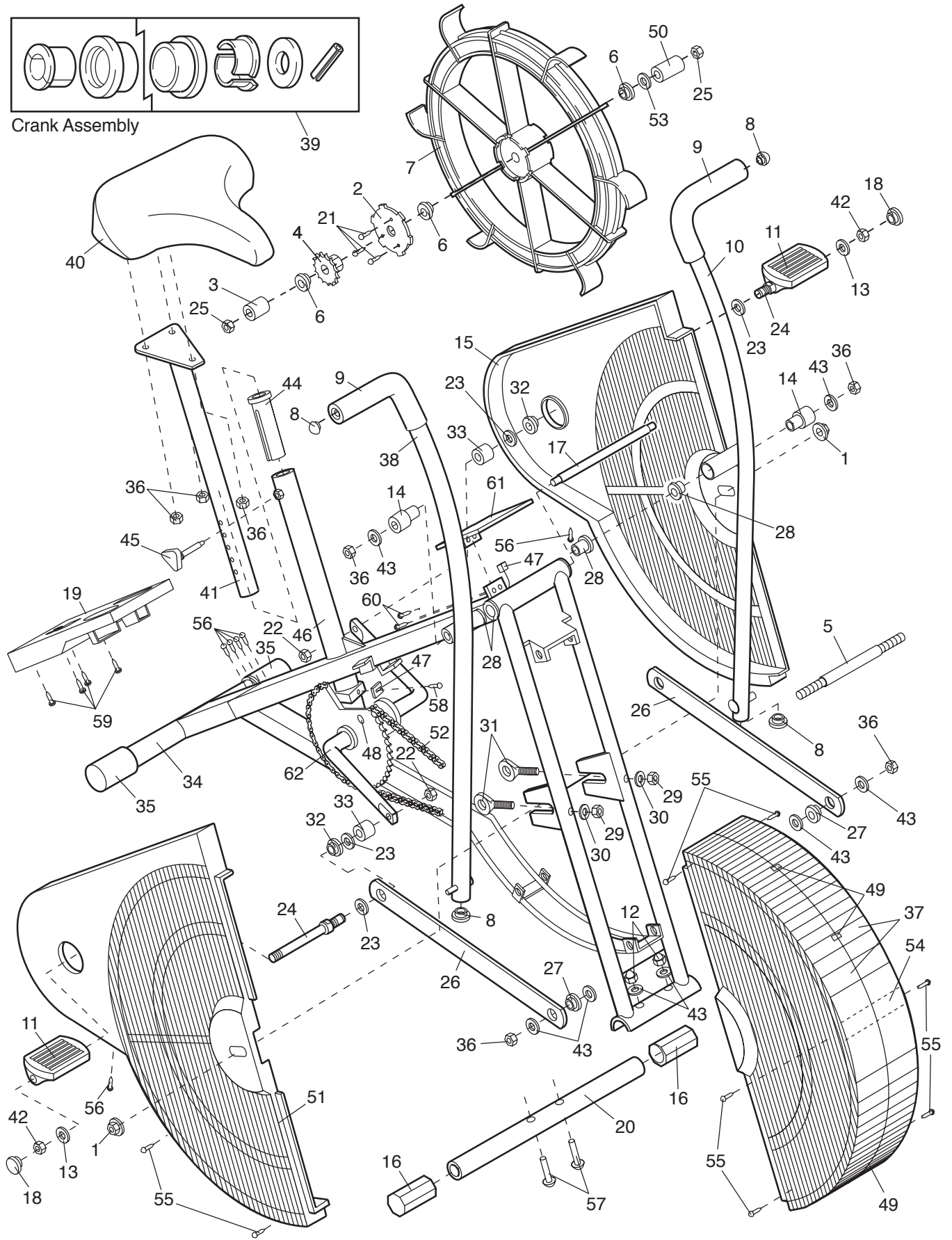
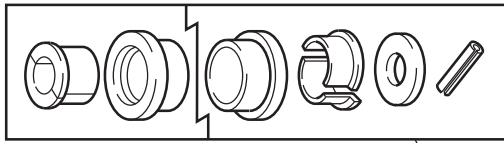



Model No. 831.288262

QUESTIONS?

If you find that:

- you need help assembling or operating the LIFESTYLER® DT1000
- a part is missing
- or you need to schedule repair service

call our toll-free HELPLINE

1-800-736-6879

Monday–Saturday, 7 am–7 pm
Central Time (excluding holidays)

REPLACEMENT PARTS

If parts become worn and need to be replaced, call the following toll-free number

**1-800-FON-PART
(1-800-366-7278)**

The model number and serial number of your LIFESTYLER® DT1000 are listed on a decal attached to the frame. See the front cover of this manual to find the location of the decal.

All replacement parts are available for immediate purchase or special order when you visit your nearest SEARS Service Center. To request service or to order parts by telephone, call the toll-free numbers listed at the left.

When requesting help or service, or ordering parts, please be prepared to provide the following information:

- The NAME OF THE PRODUCT (LIFESTYLER® DT1000)
- The MODEL NUMBER OF THE PRODUCT (831.288262)
- The KEY NUMBER OF THE PART (see page 10)
- The DESCRIPTION OF THE PART (see page 10)

FULL 90 DAY WARRANTY

For 90 days from the date of purchase, if failure occurs due to defect in material or workmanship in this SEARS BIKE EXERCISER, contact the nearest SEARS Service Center throughout the United States and SEARS will repair or replace the BIKE EXERCISER, free of charge.

This warranty does not apply when the BIKE EXERCISER is used commercially or for rental purposes.

This warranty gives you specific legal rights, and you may also have other rights which vary from state to state.

SEARS, ROEBUCK AND CO., DEPT. 817WA, HOFFMAN ESTATES, IL 60179