

Important information

Copyright

© 2014 Deliberant
This guide and the software described in it are copyrighted with all rights reserved. No part of this publication may be reproduced, transmitted, transcribed, stored in a retrieval system, or translated into any language in any form by any means without the written permission of Deliberant.

Notice

Product size and shape are subject to change without prior notice, and actual product appearance may differ from that depicted in the user guide.
While the information in this guide has been compiled with great care, it may not be deemed an assurance of product characteristics. Deliberant shall be liable only to the degree specified in the terms of sale and delivery.
The reproduction and distribution of the documentation and software supplied with this product and the use of its contents is subject to written authorization from Deliberant.

Trademarks

Deliberant logo is trademark of Deliberant LLC.
All other registered and unregistered trademarks in this document are the sole property of their respective owners.

FCC warning

This equipment has been tested and found to comply with the limits for a Class B digital device, pursuant to Part 15 of the FCC Rules. These limits are designed to provide reasonable protection against harmful interference in a residential installation.
This equipment generates, uses, and can radiate radio frequency energy and, if not installed and used in accordance with the instructions, may cause harmful interference to radio communications. However, there is no guarantee that interference will not occur in a particular installation. If this equipment does cause harmful interference to radio or television reception, which can be determined by turning the equipment off and on, the user is encouraged to try to correct the interference by one of the following measures:
• Reorient or relocate the receiving antenna.
• Increase the separation between the equipment and receiver.
• Connect the equipment into an outlet on a circuit different from that to which the receiver is connected.
• Consult the dealer or an experienced radio/TV technician for help.
• This device complies with Part 15 of the FCC Rules. Operation is subject to the following two conditions: (1) This device may not cause harmful interference, and (2) this device must accept any interference received, including interference that may cause undesired operation.

FCC caution

To assure continued compliance, any changes or modifications not expressly approved by the party responsible for compliance could void the user's authority to operate this equipment.

The device includes it's antenna must be installed to provide a separation distance of at least 60 cm away from the user body.

The device must be professional installed as fixed point-to-point access points only.

CE mark warning

This is a Class A product. In a domestic environment this product may cause radio interference in which case the user may be required to take adequate measures.

R&TTE compliance statement

This equipment complies with all the requirements of the Directive 1999/5/EC of the European Parliament and the Council of 9 March 1999 on Radio Equipment and Telecommunication Terminal Equipment and the Mutual Recognition of their Conformity (R&TTE).
The R&TTE Directive repeals and replaces in the directive 98/13/EEC (Telecommunications Terminal Equipment and Satellite Earth Station Equipment) As of April 8, 2000.

Safety

This equipment is designed with the utmost care for the safety of those who install and use it. However, special attention must be paid to the dangers of electric shock and static electricity when working with electrical equipment. All guidelines of this manual and of the computer manufacturer must therefore be allowed at all times to ensure the safe use of the equipment.

EU countries not intended for use

None.

Contact us

Technical support

If you encounter problems when installing or using this product, please consult the Deliberant website at www.deliberant.com for:

- Direct contact to the Deliberant support centers.
- Frequently Asked Questions (FAQ).
- Download area for the latest software, user documentation and product updates.

Contacts

EU office:
Sualetekio ave. 15 – 610
LT-10244, Lithuania
support@wilibox.com

US office:
Deliberant
138 Mountain Brook Drive
Canton, GA 30115
United States of America
For support: support@deliberant.com
For sales enquiries:
sales@deliberant.com

Default login settings:

IP address: DHCP client
(fallback IP 192.168.2.66)
Login / Pass: admin / admin01

Declaration of conformity

Česky [Czech]
Deliberant tímto prohlašuje, že tento Deliberant DLB 5-15, DLB 2-9, je ve shodě se základními požadavky a dalšími příslušnými ustanoveními směrnice 1999/5/ES.
Dansk [Danish]
Undertegnede Deliberant erklærer herved, at følgende udstyr Deliberant DLB 5-15, DLB 2-9, overholder de væsentlige krav og øvrige relevante krav i direktiv 1999/5/EF.
Nederlands [Dutch]
Hierbij verklaart Deliberant dat het toestel Deliberant DLB 5-15, DLB 2-9, in overeenstemming is met de essentiële eisen en de andere relevante bepalingen van richtlijn 1999/5/EG. Bij deze verklaart Deliberant dat deze Deliberant DLB 5-15, DLB 2-9, voldoet aan de essentiële eisen en aan de overige relevante bepalingen van Richtlijn 1999/5/EC.
English
Hereby, Deliberant, declares that this Deliberant DLB 5-15, DLB 2-9, is in compliance with the essential requirements and other relevant provisions of Directive 1999/5/EC.
Eesti [Estonian]
Käesolevaga kinnitab Deliberant seadme Deliberant DLB 5-15, DLB 2-9, vastavust direktiivi 1999/5/EÜ põhinõuetele ja nimetatud direktiivist tulenevatele teistele asjakohastele sätetele.
Suomi [Finnish]
Deliberant vakuuttaa täten että Deliberant DLB 5-15, DLB 2-9, tyyppinen laite on direktiivin 1999/5/EY oleellisten vaatimusten ja sitä koskevien direktiivin muiden ehtojen mukainen.
Français [French]
Par la présente Deliberant déclare que l'appareil Deliberant DLB 5-15, DLB 2-9, est conforme aux exigences essentielles et aux autres dispositions pertinentes de la directive 1999/5/CE.
Par la présente, Deliberant déclare que ce Deliberant DLB 5-15, DLB 2-9, est conforme aux exigences essentielles et aux autres dispositions de la directive 1999/5/CE qui lui sont applicables.
Deutsch [German]
Hiermit erkläre Deliberant, dass sich diese Deliberant DLB 5-15, DLB 2-9, in Übereinstimmung mit den grundlegenden Anforderungen und den anderen relevanten Vorschriften der Richtlinie 1999/5/EG befindet. (BMW)
Hiermit erkläre Deliberant die Übereinstimmung des Gerätes Deliberant DLB 5-15, DLB 2-9, mit den grundlegenden Anforderungen und den anderen relevanten Festlegungen der Richtlinie 1999/5/EG. (Wien)
Ελληνικά [Greek]
ΜΕ ΤΗΝ ΠΑΡΟΥΣΑ Deliberant ΔΗΛΩΝΕΙ ΟΤΙ Deliberant DLB 5-15, DLB 2-9, ΣΥΜΜΟΡΦΩΝΕΤΑΙ ΠΡΟΣ ΤΙΣ ΟΥΣΙΩΔΕΙΣ ΑΠΑΙΤΗΣΕΙΣ ΚΑΙ ΤΙΣ ΛΟΙΠΕΣ ΣΧΕΤΙΚΕΣ ΔΙΑΤΑΞΕΙΣ ΤΗΣ Ο ΔΗΠΙΑΣ 1999/5/ΕΚ.



deliberant

DLB 5-15 / DLB 2-9 INSTALLATION

Magyar [Hungarian]

Alulírott, Deliberant nyilatkozom, hogy a Deliberant DLB 5-15, DLB 2-9, megfelel a vonatkozó alapvető követelményeknek és az 1999/5/EC irányelv egyéb előírásainak.
Íslenska [Icelandic]
Hér með lýsir Deliberant yfir því að Deliberant DLB 5-15, DLB 2-9, er í samræmi við grunnkröfur og aðrar kröfur, sem gerðar eru í tilskipun 1999/5/EC.
Italiano [Italian]

Con la presente Deliberant dichiara che questo Deliberant DLB 5-15, DLB 2-9, è conforme ai requisiti essenziali ed alle altre disposizioni pertinenti stabilite dalla direttiva 1999/5/CE.
Latviski [Latvian]
Ar šis Deliberant deklarē, ka Deliberant DLB 5-15, DLB 2-9, atbilst Direktīvas 1999/5/EK būtiskajām prasībām un citiem ar to saistītajiem noteikumiem.
Lietuvių [Lithuanian]

Šiuo Deliberant deklaruoją, kad šis Deliberant DLB 5-15, DLB 2-9, atitinka esminius reikalavimus ir kitas 1999/5/EB Direktivos nuostatas.
Malti [Maltese]
Hawnhekk, Deliberant, jiddikjara li dan Deliberant DLB 5-15, DLB 2-9, jikkonforma mal-hiżjijiet essenzjali u ma provvedimenti oħrajn relevanti li hemm fid-Direttiva 1999/5/EC.
Norsk [Norwegian]
Deliberant erklærer herved at utstyret Deliberant DLB 5-15, DLB 2-9, er i samsvar med de grunnleggende krav og øvrige relevante krav i direktiv 1999/5/EF.
Slovensky [Slovak]
Deliberant týmto vyhlasuje, že Deliberant DLB 5-15, DLB 2-9, spĺňa základné požiadavky a všetky príslušné ustanovenia Smernice 1999/5/ES.
Svenska [Swedish]

Härmed intygar Deliberant att denna Deliberant DLB 5-15, DLB 2-9, står i överensstämmelse med de väsentliga egenskapskrav och övriga relevanta bestämmelser som framgår av direktiv 1999/5/EG.

Español [Spanish]
Por medio de la presente Deliberant declara que el Deliberant DLB 5-15, DLB 2-9, cumple con los requisitos esenciales y cualesquiera otras disposiciones aplicables o exigibles de la Directiva 1999/5/CE.
Polski [Polish]

Niniejszym, firma Deliberant oświadcza, że produkt serii Deliberant DLB 5-15, DLB 2-9, spełnia zasadnicze wymagania i inne istotne postanowienia Dyrektywy 1999/5/EC.
Português [Portuguese]
Deliberant declara que este Deliberant DLB 5-15, DLB 2-9, está conforme com os requisitos essenciais e outras disposições da Directiva 1999/5/CE

To get full CE declaration of conformity documents, refer at <http://www.deliberant.com/conformity>.

Installation

①

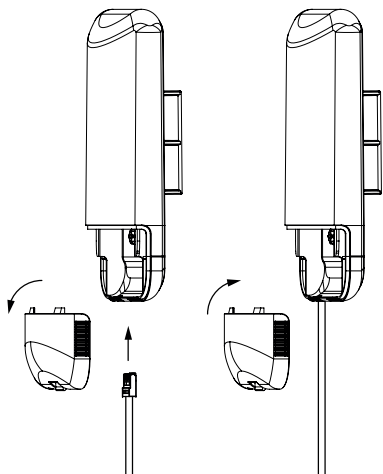

②

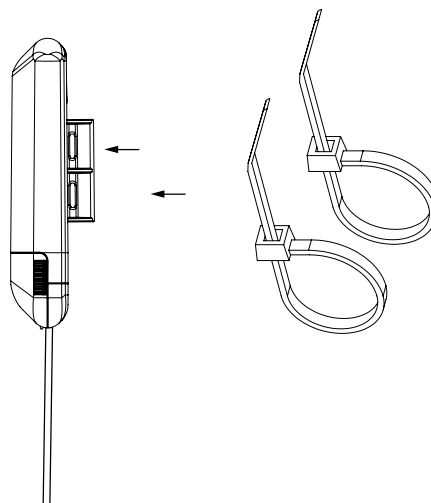

③

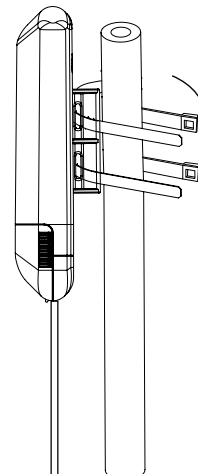

Package contents

PoE connection

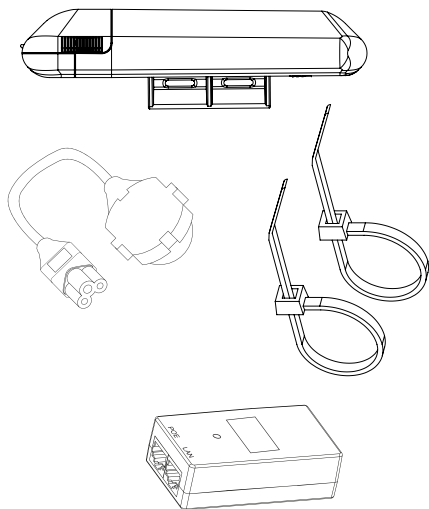

STP 24 AWG
solid copper conductor

