

LT1511 Level 2, Smart Battery Charger Demo Board with SMBus Interface

DESCRIPTION

The DC101 board is a standalone Smart Battery charger that receives Charging Voltage(), Charging Current() and AlarmWarning() commands from the Smart Battery via the System Management Bus (SMBus) and sets charging current and voltage accordingly. The charger continu-

ously monitors the built-in thermistor in the battery. The thermistor information is used by the software to inhibit charging at temperature extremes and to set charging strategy for different battery chemistries.

LT, LTC and LT are registered trademarks of Linear Technology Corporation.

PERFORMANCE SUMMARY

PARAMETER	CONDITIONS	MIN	TYP	MAX	UNIT
Input Voltage		16	24	27	V
Input Current	Hardware Limited			2	A
Output Current	Software Limited	0		2.5	A
Output Voltage	Software Limited	4		20	V
Thermistor Resistance	Ni-MH Battery	3		30	kΩ
	Li-Ion Battery	0.5	1	1.5	kΩ

BLOCK DIAGRAM AND BOARD PHOTO

DC101 Smart Battery Charger

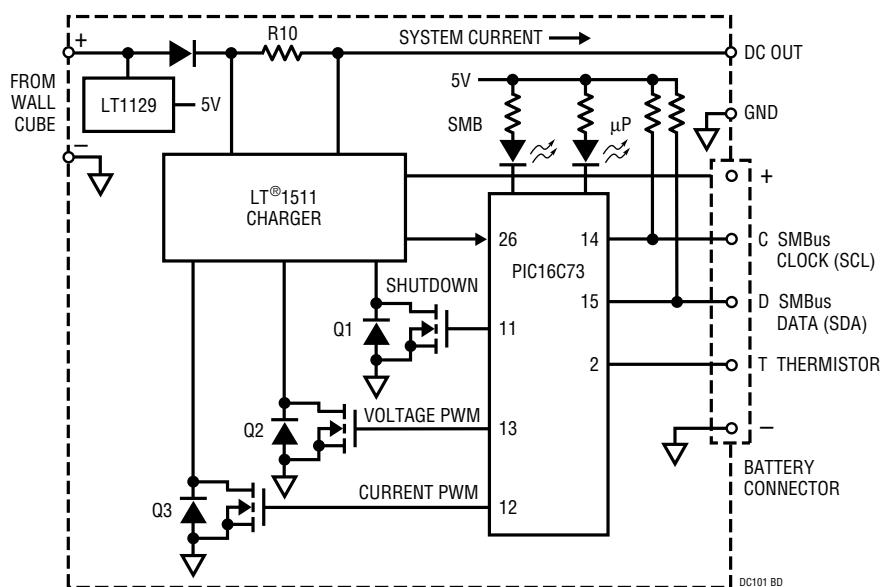

Component Side

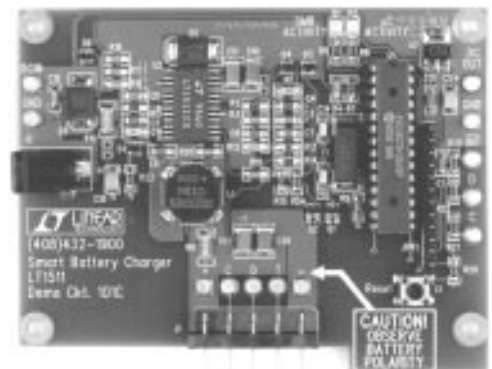

DEMO MANUAL DC101

SMART BATTERY CHARGER

SCHEMATIC DIAGRAM

Smart Battery Charger with SMBus Interface

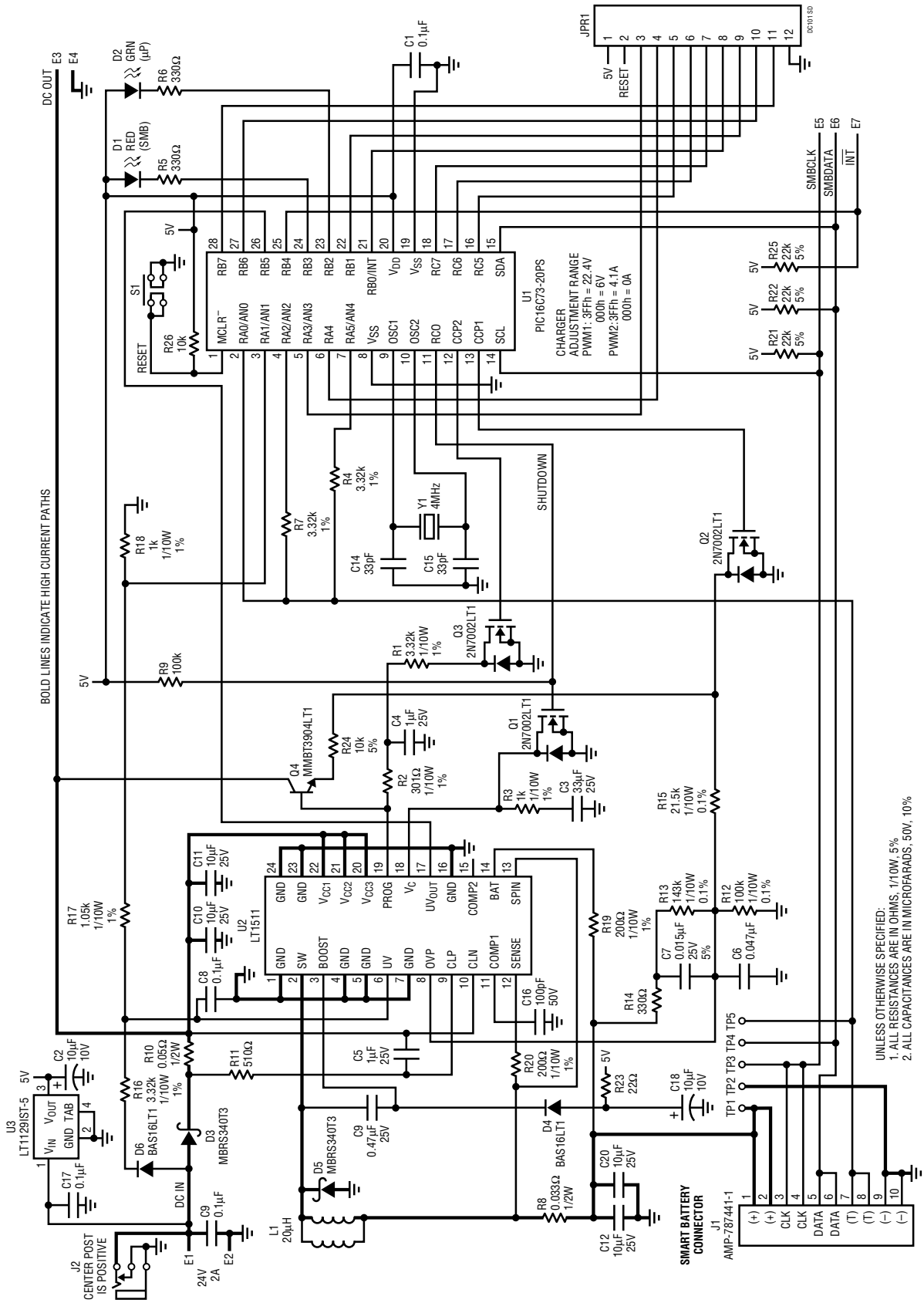

PACKAGE DIAGRAM

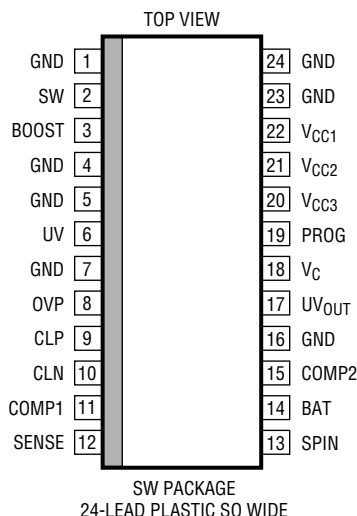

LT1511CSW

PARTS LIST

REFERENCE DESIGNATOR	QUANTITY	PART NUMBER	DESCRIPTION	VENDOR	TELEPHONE
C1, C8, C17, C19	4	12065C104KATMA	0.1μF 50V Chip Capacitor	AVX	(803) 946-0362
C2, C18	2	TAJB106M010	10μF 10V Tantalum Capacitor	AVX	(207) 282-5111
C3	1	12063G334ZAT2	0.33μF 25V Chip Capacitor	AVX	(803) 946-0362
C4, C5	2	12063G105ZATMA	1μF 25V Chip Capacitor	AVX	(803) 946-0362
C6	1	12065C473KAT	0.047μF 50V 10% Chip Capacitor	AVX	(803) 946-0362
C7	1	12063C153KAT2	0.015μF 25V 5% Chip Capacitor	AVX	(803) 946-0362
C9	1	12063G474ZAT2	0.47μF 25V Chip Capacitor	AVX	(803) 946-0362
C10, C11, C12, C20	4	THCS50E1E106Z	10μF 25V Ceramic Capacitor	Marcon	(847) 696-2000 x374
C14, C15	2	1206A330KAT2	33pF 50V Chip Capacitor	AVX	(803) 946-0362
C16	1	VJ1206A101KXA	100pF 50V Chip Capacitor	Vitramon	(203) 268-6261
D1	1	SF1-BR	Red LED	Data Display Product	(800) 421-6815
D2	1	SF1-G	Green LED	Data Display Product	(800) 421-6815
D3, D5	2	MBRS340T3	Diode	Motorola	(602) 244-3576
D4, D6	2	BAS16LT1	Diode	Motorola	(602) 244-3576
J1	1	AMP-787441-1	Connector	AMP	(717) 780-4409
J2	1	CUI-PJ-002A	Connector	Cui-Stack	(503) 643-4899
JPR1	1	3801S-12-G1	12-Pin Header Jumper	Comm Con Conn.	(818) 301-4200
L1	1	CTX20-4	20μH Inductor	Coiltronics	(407) 241-7876
Q1, Q2, Q3	3	2N7002LT	N-Channel MOSFET	Motorola	(602) 244-3576
Q4	1	MMBT3904LT1	NPN Transistor	Motorola	(602) 244-4342
R1, R4, R16	3	CR32-3321F-T	3.32k 1/8W 1% Resistor	AVX	(803) 946-0524
R2	1	CR32-3010F-T	301Ω 1/8W 1% Resistor	AVX	(803) 946-0524
R3, R18	2	CR32-1001F-T	1k 1/8W 1% Resistor	AVX	(803) 946-0524

DEMO MANUAL DC101

SMART BATTERY CHARGER

PARTS LIST

REFERENCE DESIGNATOR	QUANTITY	PART NUMBER	DESCRIPTION	VENDOR	TELEPHONE
R5, R6, R14	3	CR32-331J-T	330Ω 1/8W 5% Resistor	AVX	(803) 946-0524
R7	1	BCR1/8-3322F-T	33.2k 1/8W 1% Resistor	Beckman	(714) 447-2345
R8	1	LR2010-01-R033-J	0.033Ω 1/2W 5% Resistor	IRC	(512) 992-7900
R9	1	CR32-104J-T	100k 1/8W 5% Resistor	AVX	(803) 946-0524
R10	1	LR2010-01-R050-J	0.05Ω 1/2W 5% Resistor	IRC	(512) 992-7900
R11	1	CR32-511J-T	510Ω 1/8W 5% Resistor	AVX	(803) 946-0524
R12	1	W1206R-03-1003-B	100k 1/8W 0.1% Resistor	IRC	(512) 992-7900
R13	1	W1206R-03-1433-B	143k 1/10W 0.1% Resistor	IRC	(512) 992-7900
R15	1	W1206R-03-2152-B	21.5k 1/10W 0.1% Resistor	IRC	(512) 992-7900
R17	1	CR32-1051F-T	1.05k 1/8W 1% Resistor	AVX	(803) 946-0524
R19, R20	2	CR32-2000F-T	200Ω 1/8W 1% Resistor	AVX	(803) 946-0524
R21, R22, R25	3	CR32-223J-T	22k 1/10W 5% Resistor	AVX	(803) 946-0524
R23	1	CR32-220J-T	22Ω 1/10W 5% Resistor	AVX	(803) 946-0524
R24, R26	2	CR1206-103J	10k 1/8W 5% Resistor	Dale	(605) 665-9301
S1	1	MJTP1230	PB Switch	MORS-ASC	(617) 246-1007
TP1 to TP5, E1 to E7	12	1502-2	Turret Testpoint	Keystone	(718) 956-8900
U1	1	PIC16C73-20SP	Microcontroller IC	Microchip	(602) 786-7200
U2	1	LT1511	Battery Charger IC	LTC	(408) 432-1900
U3	1	LT1129IST-5	Voltage Regulator IC	LTC	(408) 432-1900
XU1	1	7167-14-G2	Sockets IC	Comm Con	(818) 301-4200
Y1	1	MA-505-4.00M-C2	4MHz Crystal	Epson (USA)	(310) 787-6300

OPERATION

Input Voltage: The nominal input voltage of the board is 24V DC. The input voltage must be higher than the battery voltage by a minimum of 3V. The minimum input voltage is 16V, limited by the undervoltage lockout circuit in the LT1511 and set by resistors R16, R17 and R18. The highest input voltage is 27.4V, limited by the maximum input voltage of the LT1511. The input is protected against reverse polarity up to 30V.

Input Current: The sum of the system current and the charger input current is limited by the LT1511 to 2A. When both the system current and the charger input current requirements are high, the charger reduces the charging current to meet the 2A current limit.

Red LED: A red LED indicates SMBus activity. It lights up for about 1 second when the charger recognizes its own address (12 hex) on the SMBus.

Green LED: A flashing green LED indicates microprocessor activity and charger status. Fast blinking (approximately 8Hz) indicates normal microprocessor activity and either trickle charge or shutdown charger status. After valid voltage and current data have been received, the blinking speed of the LED slows down to about 2Hz, indicating normal charging.

OPERATION

Battery Removal, Thermistor Measurements: The charger periodically checks the thermistor in the battery through the T-terminal. When the thermistor is out of normal operating temperature range, the charger switches to trickle charge mode and increases the flashing frequency of the green LED to indicate an abnormal charging condition. When the resistance of the thermistor is in the $500\Omega < R_{TH} < 1.5k$ range, the charger assumes a Li-Ion battery is at the output. Instead of trickle charging the battery it shuts down the charger until a valid voltage and current request arrives from the battery. An open thermistor forces the charger into trickle charge mode and the charger disregards data on the SMBus.

System Management Bus (SMBus)

When charge in the Smart Battery (SB) drops below 85% of the nominal capacity, it initiates communication over the SMBus every 64 seconds. After sending a START sequence, the battery addresses the Smart Battery charger and waits for an acknowledgment (ACK) from it. If the charger fails to acknowledge the word, the battery terminates further communication by placing a STOP sequence onto the SMBus. If the charger acknowledges (ACK) the reception of the first word, the battery continues the communication sequence and sends six more words to the charger. The complete current and voltage request communication sequence is as follows:

START
address (12 hex)
Charging Current() command code (14 hex),
current_LSB
current_MSB,
address (12 hex)
Charging Voltage() command code (15 hex)
voltage_LSB
voltage_MSB
STOP

The idealized SMBus waveforms shown in Figure 1 illustrate SMBus communication between the battery and the charger. The first seven bits after the START sequence are the battery address. The R/W bit tells the charger that the battery is attempting to write to the charger. During the acknowledge period (ACK), the charger becomes active and pulls the data line (SDA) low, indicating reception of a data word. When reception of the data word is not acknowledged by the charger, the battery terminates the communication by sending a STOP sequence to the bus. The clock pulses for the communication are always generated by the battery (BUS MASTER).

“C” Source Code

The latest version of “C” language source code, header file, code file and hex dump file is provided on a 3.5" disk.

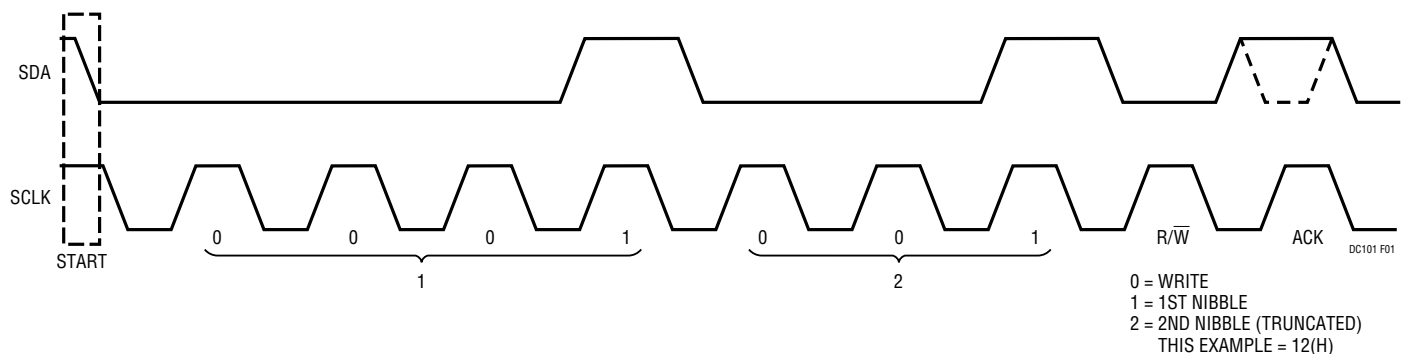

Figure 1. SMBus Waveforms Indicating Battery Address

OPERATION

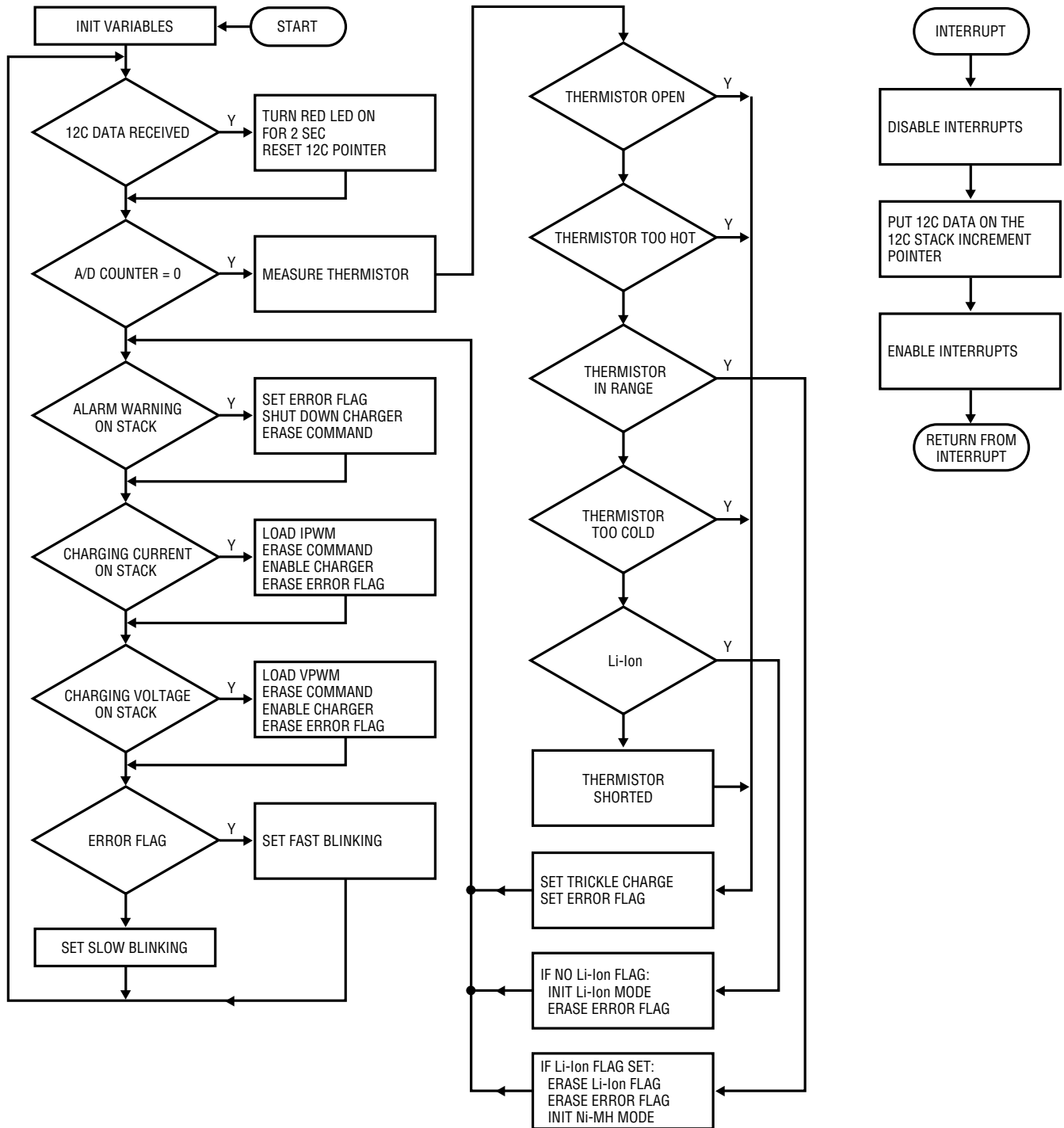
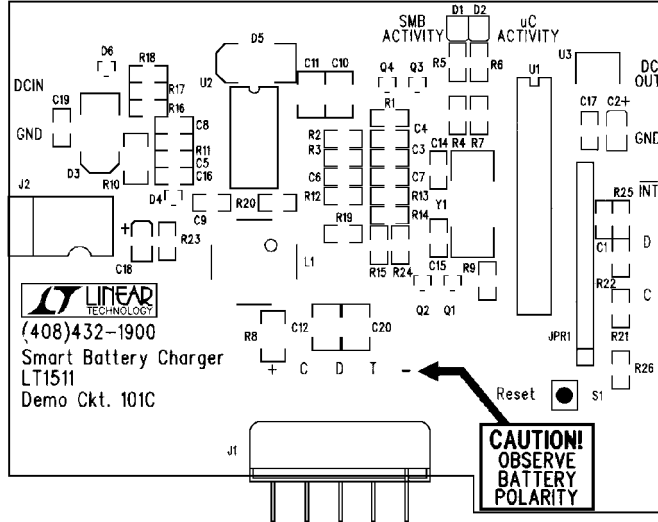
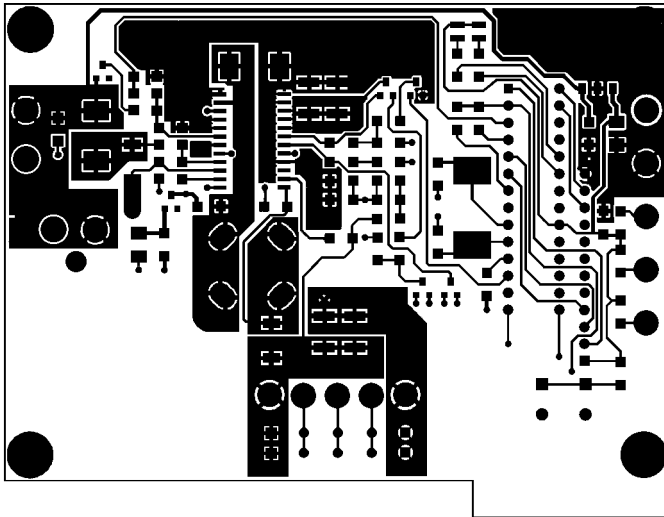

Figure 2. Software Flowchart

PCB LAYOUT AND FILM



Component Side Silkscreen



Component Side

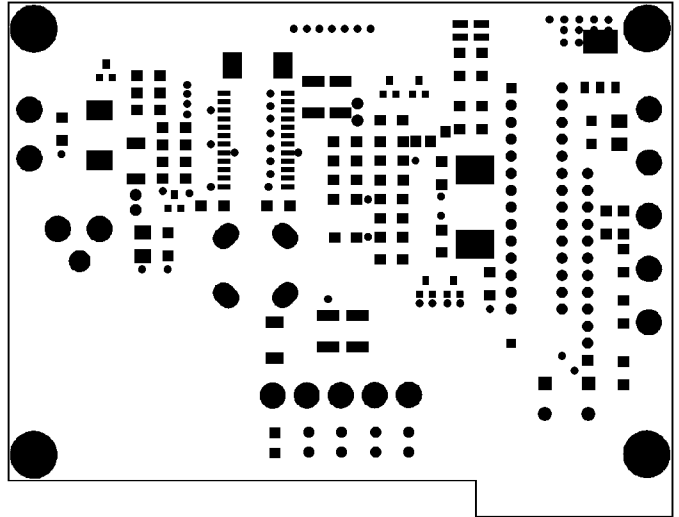

Component Side Solder Mask

DEMO MANUAL DC101

SMART BATTERY CHARGER

PCB LAYOUT AND FILM

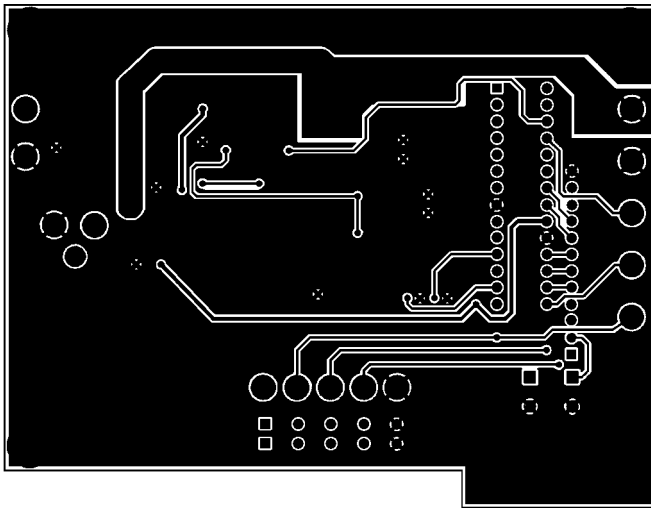

Solder Side

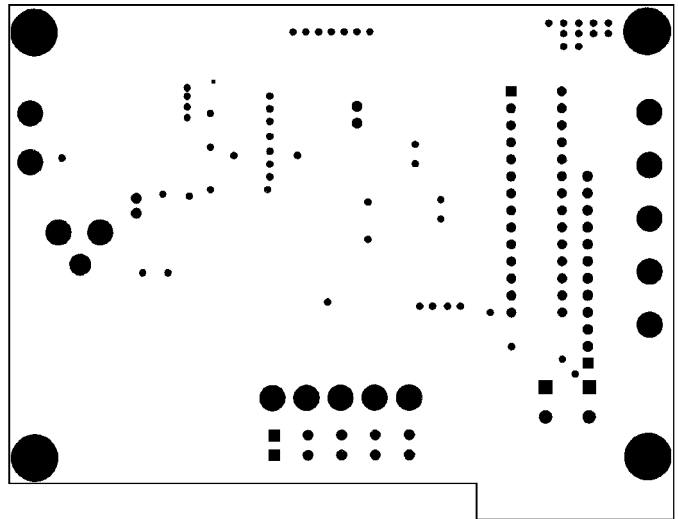

Solder Side Solder Mask

PC FAB DRAWING

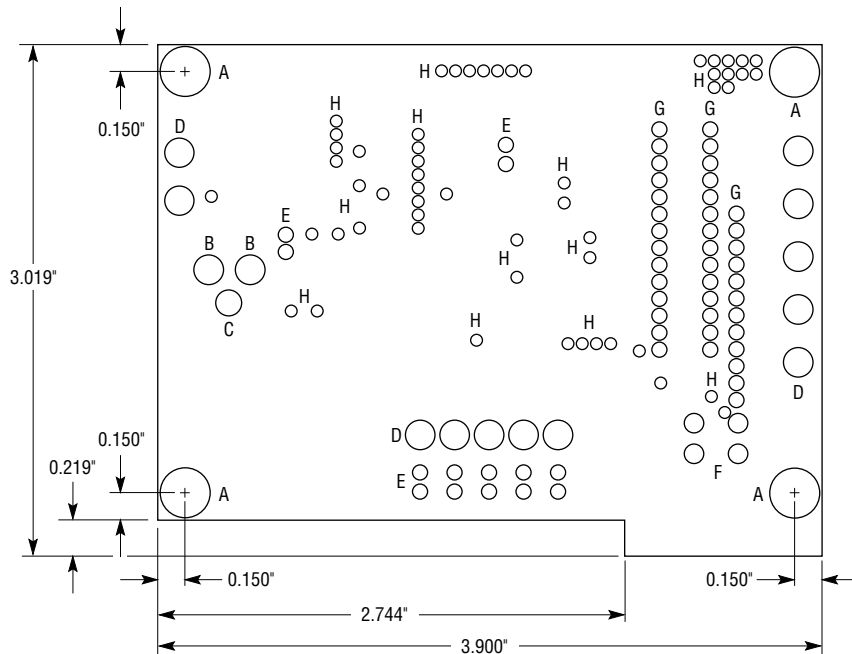

SYMBOL	DIAMETER	NUMBER OF HOLES
A	125	4
B	120	2
C	100	1
D	94	12
E	40	14
F	39	4
G	37	40
H	18	55
TOTAL HOLES		132

- NOTES**
1. MATERIAL: 2 LAYERS, 0.062" THICK.
FR-4 GLASS EPOXY 2 OZ COPPER CLAD
 2. ALL HOLES SHALL BE PLATED THROUGH
 3. PLATE THROUGH HOLES WITH COPPER
0.0014 MIN THICKNESS. ALL HOLE SIZES
IN HOLE TABLE ARE AFTER PLATING
 4. SILKSCREEN: WITH WHITE EPOXY
NONCONDUCTIVE INK
 5. FINISH: SMOBC
 6. SOLDER MASK: USE FILM PROVIDED, GREEN

DC101 FD