

IN THE BOX

Sharper Image  Polaroid



Bluetooth Headphone

PBT106 | USER MANUAL



Bluetooth Headphone

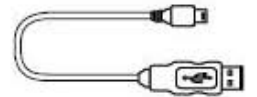

Micro USB
Charging Cable

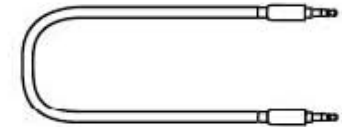

3.5mm Auxiliary
Cable



Questions?
Need some help?
This manual will help you
enjoy your new product



If you still have questions,
call our help line:
1-877-768-8481



or visit us at:
www.southern telecom.com
Click on "Product Support"

LOCATION OF CONTROLS

1. Microphone
2. LED Indicator
 - Flashes RED and BLUE when pairing.
 - Solid RED when charging.
 - Solid BLUE when fully charged.
3. AUX-IN port
4. Micro USB Charging Port:
5. [-] button:
 - Long press to decrease the volume.
 - Quick press to replay the previous song.
6. [▶|||] button:
 - Power headphones ON and OFF
 - Quick press to pause music.
 - Quick press again to resume music playback.
 - Quick press to answer / end phone call.
7. [+] button:
 - Long press to increase the volume.
 - Quick press to skip to the next song.

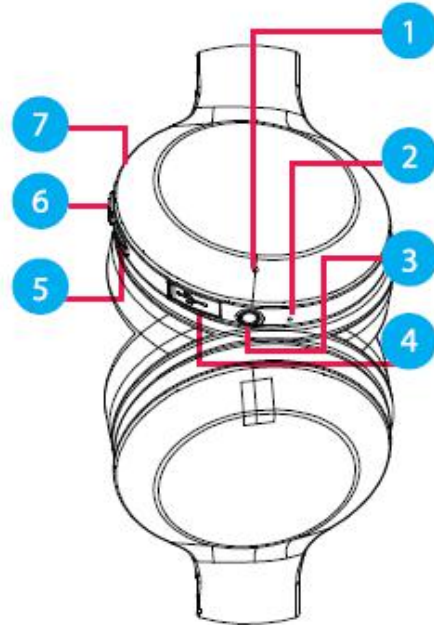

CHARGING THE HEADPHONES

- Connect the **small** end of the micro USB cable to the micro USB port on the headphones.

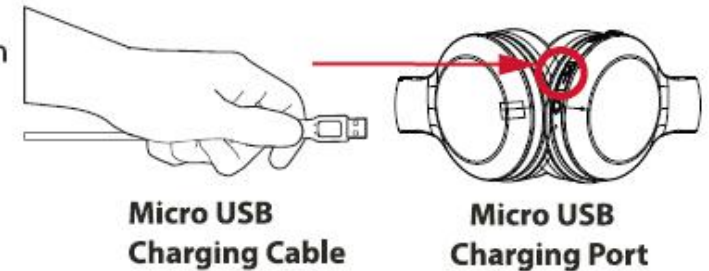

- Connect the **larger** end of the micro USB cable to your computer or AC Adaptor (not included).

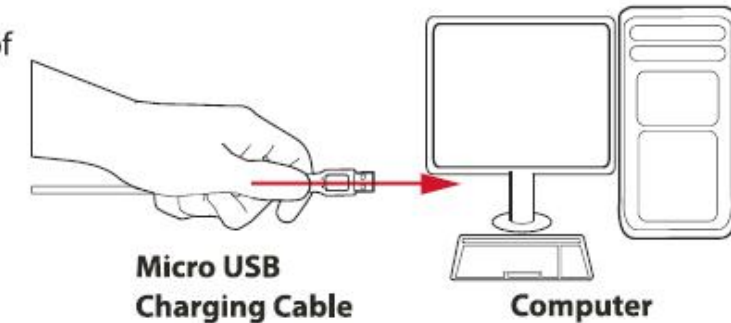

- The LED indicator **will** remain RED when charging and **will** turn BLUE when charging is complete.
- When the headphones are **fully** charged, remove the micro USB cable.

PAIRING THE HEADPHONES

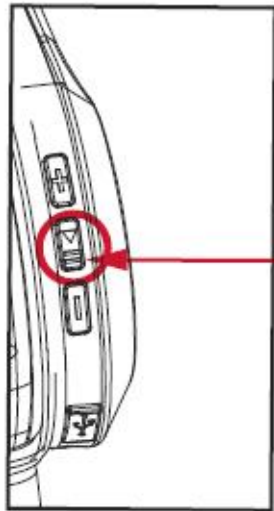

Power [ON/OFF]
switch

- Long press the [] button for approximately 6 seconds. A tone is heard and the LED indicator will flash RED and BLUE to indicate that the headphones are in pairing mode.



If there are no paired devices in range when the headphones are in Bluetooth mode, it will go into pairing mode automatically. If a paired device is in range, the headphones will connect to it automatically.

PAIRING THE HEADPHONES (cont'd)

- Set your mobile phone or other Bluetooth-enabled device to search for Bluetooth devices (for detailed instructions for pairing your Bluetooth-enabled device, consult your mobile device's user documentation).



On an iPhone or Android phone
• Go to **SETTINGS > BLUETOOTH**
(Make sure **Bluetooth** is turned ON)

PAIRING THE HEADPHONES (cont'd)



- **Select PBT106 from the list of found devices.**

Found devices

- If required, enter the password 0000. Select YES or OK to pair with your device.
- After a successful pairing, a tone is heard and the LED indicator will remain GREEN.



The screenshots above are typical of many Bluetooth-enabled devices in the market today, and are used to assist in the explanation of the pairing process. Your Bluetooth-enabled device's interface and interaction with the headphones may differ slightly from the illustrations shown.

USING THE HEADPHONES

Powering ON/OFF

- To turn the headphones ON, long press the [▶||] button for approximately 3 seconds.
- To turn the headphones OFF, long press the [▶||] button again for approximately 3 seconds.

Playing Music

- Quick press the [▶||] button to pause music.
- Quick press the [▶||] button again to resume music playback.
- Quick press the [+] button to skip to the next song.
- Quick press the [-] button to replay the previous song.

Volume Control

- Long press the [-] to decrease the volume.
- Long press the [+] to increase the volume.

Answering / Ending Phone Calls

- Quick press the [▶||] button to answer an incoming call.
- Quick press the [▶||] button again to end the call.



You can also adjust the volume from your connected device's volume control.

USING AS WIRED HEADPHONES

- Insert one end of the 3.5mm auxiliary cable into the AUX port under the headphones.

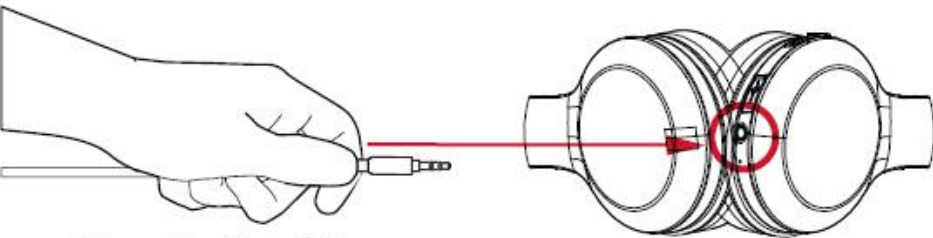

3.5mm Auxiliary Cable

Insert the other end of the 3.5mm auxiliary cable into the headphone jack on your smartphone, tablet or MP3 player.

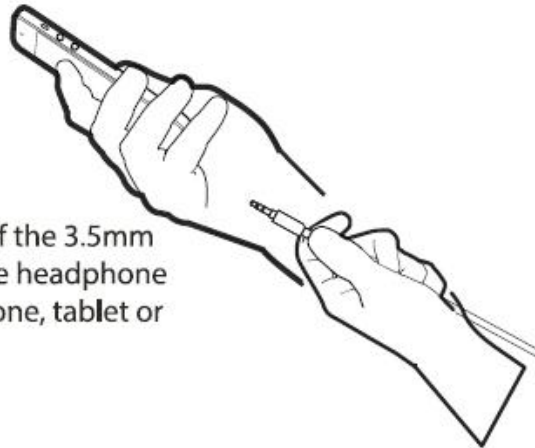

TROUBLESHOOTING

 My Bluetooth device is not able to pair with the speaker.

1. Make sure the headphones are turned ON before beginning the pairing process.
2. Keep the headphones and Bluetooth-enabled device within 3 feet of each other during the pairing process.
3. Check that YOUR device's Bluetooth feature is turned ON.
4. Try repeating the pairing process; see "Pairing the Headphones."
5. Make sure the headphones are charged.

 I cannot get the speaker into pairing mode.

1. Make sure the headphones are turned ON before beginning the pairing process.
2. Keep the headphones and your mobile device within 3 feet of each other during the pairing process.
3. Check that the headphones are charged.

TROUBLESHOOTING (cont'd)

 I can pair the speaker with my Bluetooth device, but I cannot hear any music.

1. Make sure your Bluetooth device supports A2DP profile.
2. Turn up the volume on your Bluetooth device.
3. You may have to unpair the headphones, then re-pair to your device.

WARRANTY

This product as supplied and distributed new by AIT, Inc. ("AIT") to the original consumer purchaser is warranted by AIT against defects in material and workmanship for a period of one year from your date of purchase ("Warranty"). In the unlikely event that this product is defective, or does not perform properly, you may within one year from your original date of purchase return it to the authorized service center for repair or exchange.

TO OBTAIN WARRANTY SERVICE:

- Call the Customer Support number located below, or go to our website portal to receive an SRO number.
- Provide proof of the date of purchase within the package (Dated bill of sale).
- Prepay all shipping costs to the authorized service center, and remember to insure your return.
- Include a return shipping address (no P.O. Boxes), a telephone contact number, and the defective unit within the package.
- Describe the defect or reason you are returning the product.

Your product will be repaired or replaced, at our option, for the same or similar model of equal value if examination by the service center determines this product is defective. Products received damaged as a result of shipping, will require you to file a claim with the carrier.

The shipping address of the authorized service center is:

Customer Service Dept. 36
c/o Southern Telecom
400 Kennedy Drive
Sayreville, NJ 08872

IN NO EVENT WILL AIT, ITS MANUFACTURERS, DISTRIBUTORS OR PLR IP HOLDINGS, LLC BE LIABLE FOR ANY INCIDENTAL, DIRECT, INDIRECT, SPECIAL, PUNITIVE OR CONSEQUENTIAL DAMAGES (SUCH AS, BUT NOT LIMITED TO, DAMAGES FOR LOSS OF PROFITS, BUSINESS, SAVINGS, DATA OR RECORDS) RELATED TO THIS PRODUCT. EXCEPT AS STATED HEREIN, NO OTHER WARRANTIES SHALL APPLY.



Questions?
Need some help?
This manual will help you
enjoy your new product



If you still have questions,
call our help line:
1-877-768-8481



or visit us at:
www.southerntelecom.com
Click on "Product Support"



Note: This equipment has been tested and found to comply with the limits for a Class B digital device, pursuant to part 15 of the FCC Rules. These limits are designed to provide reasonable protection against harmful interference in a residential installation. This equipment generates, uses and can radiate radio frequency energy and, if not installed and used in accordance with the instructions, may cause harmful interference to radio communications. However, there is no guarantee that interference will not occur in a particular installation. If this equipment does cause harmful interference to radio or television reception, which can be determined by turning the equipment off and on, the user is encouraged to try to correct the interference by one or more of the following measures:

- Reorient or relocate the receiving antenna.
- Increase the separation between the equipment and receiver.
- Connect the equipment into an outlet on a circuit different from that to which the receiver is connected.
- Consult the dealer or an experienced radio/TV technician for help.

Caution: Any changes or modifications to this device not explicitly approved by manufacturer could void your authority to operate this equipment.

This device complies with part 15 of the FCC Rules. Operation is subject to the following two conditions: (1) This device may not cause harmful interference, and (2) this device must accept any interference received, including interference that may cause undesired operation.

The device has been evaluated to meet general RF exposure requirement. The device can be used in portable exposure condition without restriction.

PLR IP Holdings, LLC, its licensees and affiliates, fully support all electronic waste initiatives. As responsible stewards of the environment, and to avoid violating established laws, you should properly dispose of this product in compliance with all applicable regulations, directives or other governances in the area where you reside. Please check with local authorities or the retailer where you purchased this product to determine a location where you can appropriately dispose of the product.

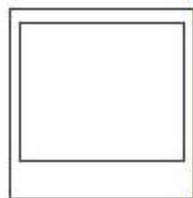

Instantly recognizable. Instantly reassuring. The Polaroid Classic Border and Polaroid Color Spectrum logos let you know you've purchased a product that exemplifies the best qualities of our brand and that contribute to our rich heritage of quality and innovation



Manufacturer: Dongguan Linpa Electronics Ltd

3F-C, B Building, Qiaojiaozhonglu 178; Shiguqiao; Tangxia County, Dongguan City