

SBT649 User Manual

**SHARPER
IMAGE®**

Wireless LED Shower Speaker



User Guide SBT649

Pairing the Speaker

1. Turn the speaker ON by long pressing the [⏻] button. A tone will be heard and the LED indicator will flash BLUE.
2. Set your mobile device to search for Bluetooth devices. When your mobile device finds the speaker, select **SBT649** from the list of found devices.
3. After a successful pairing, a tone will be heard and the LED indicator will turn solid BLUE.



If a previously paired device is in range when the speaker is turned on, the speaker will connect to it automatically.

On an iOS or Android Device

- Go to **SETTINGS > BLUETOOTH**
(Make sure Bluetooth is turned ON)



The screenshots above are typical of many Bluetooth-enabled devices in the market today, and are used to assist in the explanation of the pairing process. Your Bluetooth-enabled device's interface and interaction with the speaker may differ slightly from the illustrations above.

In the Box

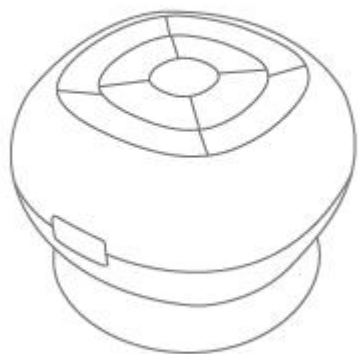

Speaker

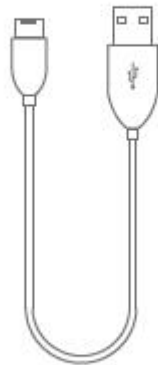

Micro USB
Charging Cable

Using the Speaker

NOTE: This speaker has an IPX-4 rating meaning it can be safely exposed to small amounts from any direction for at least 5 minutes. The speaker should NOT ever be fully submerged in water or come into contact with any other liquids as it may cause irreparable damage.

Powering ON/OFF

- Long press the [⏻] button to turn the speaker ON/OFF. When powered ON, a beep will be heard and the LED indicator will flash BLUE.

Answering/Ending Phone Calls

- Press the [📞] button to answer an incoming phone call.
- Press the [📞] button again to end the phone call.

Adjusting Volume

- Long press the [▶|] button to increase volume.
- Long press the [◀|] button to decrease volume.

Playing Music

To enjoy music wirelessly on your speaker, make sure you are paired to a Bluetooth-enabled device. Once paired, you can control media playback and volume adjustment with the controls on your paired device.

Playing/Pausing Media Playback

- Quick press the [▶|] button to pause media playback.
- Quick press the [▶|] button to resume media playback

Skipping Tracks

- Quick press the [▶|] button to skip to the next track.
- Quick press the [◀|] button to skip to the previous track.

Light Modes

- Quick press the [⏻] button to cycle through the 3 light modes. For best reactive effects, increase the volume of the speaker.

Charging the Speaker

WARNING: While charging, the speaker **should NOT be exposed to any water or liquid.**

To charge the speaker, remove the rubber seal and attach the small end of the micro USB cable to the USB charging port on the side of the speaker. Attach the large end to the USB port on a computer, USB charging device, or 5V USB adaptor.

The Charging LED indicator will turn RED while charging and turn OFF when fully charged.

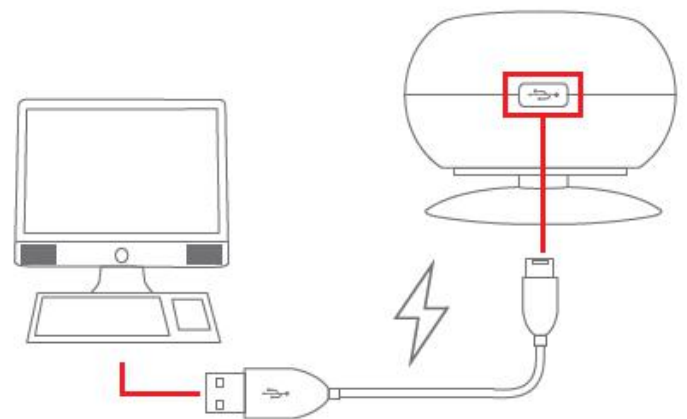

Make sure you charge your speaker for at least 2 - 3 hours before using it for the first time.

Location of Controls

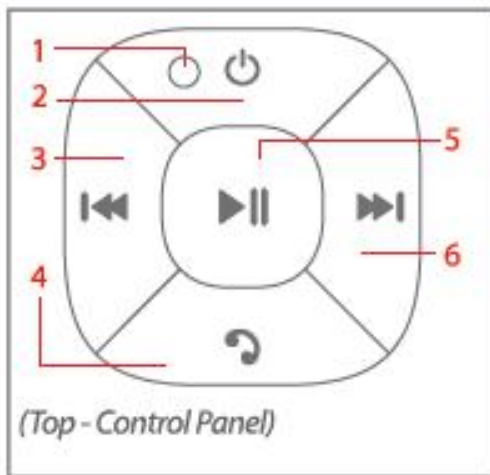

(Top - Control Panel)

1. LED Indicator

2. [⏻] Button:

- Long Press - Power speaker ON/OFF
- Quick Press - Cycle through light modes

3. [⏮] Button:

- Quick Press - Skip to previous track
- Long Press - Decrease volume

4. [☎] Button:

- Quick Press - Answer/end phone call

5. [▶⏸] Button:

- Quick Press - Play/pause media playback

6. [▶⏭] Button:

- Quick Press - Skip to next track
- Long Press - Increase volume

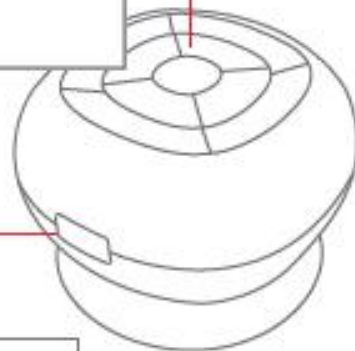

(Side)

7. USB Charging Port

8. Suction Cup

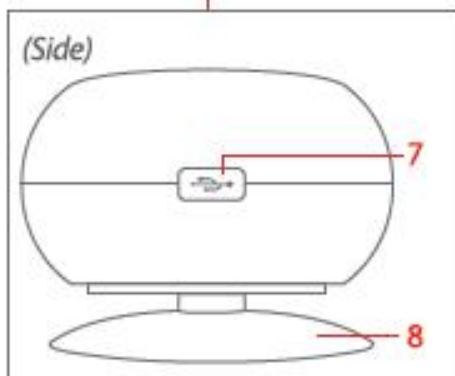

READ CAREFULLY AND KEEP THIS MANUAL

Note: This equipment has been tested and found to comply with the limits for a Class B digital device, pursuant to part 15 of the FCC Rules. These limits are designed to provide reasonable protection against harmful interference in a residential installation. This equipment generates, uses and can radiate radio frequency energy and, if not installed and used in accordance with the instructions, may cause harmful interference to radio communications. However, there is no guarantee that interference will not occur in a particular installation. If this equipment does cause harmful interference to radio or television reception, which can be determined by turning the equipment off and on, the user is encouraged to try to correct the interference by one or more of the following measures:

- Reorient or relocate the receiving antenna.
- Increase the separation between the equipment and receiver.
- Connect the equipment into an outlet on a circuit different from that to which the receiver is connected.
- Consult the dealer or an experienced radio/TV technician for help.

Caution: Any changes or modifications not expressly approved could void the user's authority to operate the equipment.

This device complies with Part 15 of the FCC Rules. Operation is subject to the following two conditions:

- (1) This device may not cause harmful interference, and
- (2) this device must accept any interference received, including interference that may cause undesired operation.

The device has been evaluated to meet general RF exposure requirement. The device can be used in portable exposure condition without restriction.

WARNING Li-ion Battery Inside

This product is fitted with a Li-ion battery. Do not damage, open, or dismantle the battery and do not use it in damp and/or corrosive conditions. Use only with compatible chargers. Never dispose of batteries in a fire, and never expose them to high temperatures. Do not expose the product to temperatures exceeding 60°C (140°F).

The crossed-out garbage bin symbol means that you must not dispose of this product together with unsorted household waste.



Rain/Moisture Warning

- Do not expose the unit to extreme temperatures (heat or cold), open flames, humid conditions, or wet conditions.
- Do not submerge in water.
- Do not open this product or attempt to repair the unit yourself should it not be working.

90 Days Limited Warranty

In the unlikely event that this product is defective, or does not perform properly, you may within ninety (90) days from your original date of purchase return it to the authorized service center for repair or exchange.

TO OBTAIN WARRANTY SERVICE:

- Call the Customer Support number located below, or go to our website portal to receive an SRO number.
- Provide proof of the date of purchase within the package (dated bill of sale).
- Prepay all shipping costs to the authorized service center, and remember to insure your return.
- Include a return shipping address (no P.O. Boxes), a telephone contact number, and the defective unit within the package.
- Describe the defect or reason you are returning the product.

Your product will be repaired or replaced, at our option, for the same or similar model of equal value if examination by the service center determines this product is defective. Products received damaged as a result of shipping will require you to file a claim with the carrier.

The shipping address of the authorized service center is:

 **Customer Service Dept. 36**
c/o Southern Telecom
400 Kennedy Drive
Sayreville NJ 08872

Should have any questions or problems concerning this product, please contact our customer service department at:

 Phone: 1-877-768-8481
Monday - Friday, 8AM - 10PM (EST)

 www.southerntelecom.com
Click on Product Support

Warranty Service Not Provided

This warranty does not cover damage resulting from accident, misuse, abuse, improper installation or operation, lack of reasonable care, and unauthorized modification. This warranty is voided in the event any unauthorized person opens, alters or repairs this product. All products being returned to the authorized service center for repair must be suitably packaged.

Limitation of Warranty

- THE WARRANTY STATED ABOVE IS THE ONLY WARRANTY APPLICABLE TO THIS PRODUCT. ALL OTHER WARRANTIES, EXPRESS OR IMPLIED (INCLUDING ALL IMPLIED WARRANTIES OF MERCHANTABILITY OR FITNESS FOR A PARTICULAR PURPOSE) ARE HEREBY DISCLAIMED. NO VERBAL OR WRITTEN INFORMATION GIVEN BY AIT, INC. ITS AGENTS, OR EMPLOYEES SHALL CREATE A GUARANTEE OR IN ANY WAY INCREASE THE SCOPE OF THIS WARRANTY.
- REPAIR OR REPLACEMENT AS PROVIDED UNDER THIS WARRANTY IS THE EXCLUSIVE REMEDY OF THE CONSUMER. AIT, INC. SHALL NOT BE LIABLE FOR INCIDENTAL OR CONSEQUENTIAL DAMAGES RESULTING FROM THE USE OF THIS PRODUCT OR ARISING OUT OF ANY BREACH OF ANY EXPRESS OR IMPLIED WARRANTY ON THIS PRODUCT. THIS DISCLAIMER OF WARRANTIES AND LIMITED WARRANTY ARE GOVERNED BY THE LAWS OF THE STATE OF NEW YORK. EXCEPT TO THE EXTENT PROHIBITED BY APPLICABLE LAW, ANY IMPLIED WARRANTY OF MERCHANTABILITY OR FITNESS FOR A PARTICULAR PURPOSE ON THIS PRODUCT IS LIMITED TO THE APPLICABLE WARRANTY PERIOD SET FORTH ABOVE.

Some states do not allow the exclusion nor limitation of incidental or consequential damages, or limitations on how long an implied warranty lasts so the above limitations on exclusions may not apply to you. This warranty gives you specific legal rights, and you also may have other rights that vary from state to state.

Questions and Customer Support

For further assistance or troubleshooting, please call our customer support line:

☎ Phone: **1-877-768-8481**

Monday - Friday 8AM - 10PM (EST)

🖥 www.southerntelecom.com

Click on **Product Support**