



73-0190-250  
4/13



# Lionel Thomas & Friends™ Remote Control Ready-To-Run Set Owner's Manual

## CAUTION—ELECTRIC TOY

NOT RECOMMENDED FOR CHILDREN UNDER EIGHT YEARS OF AGE. AS WITH ALL ELECTRIC PRODUCTS, PRECAUTIONS SHOULD BE OBSERVED DURING HANDLING AND USE TO PREVENT ELECTRIC SHOCK.

**TRANSFORMER RATINGS**—INPUT: 120-240 VAC 50/60 HZ.  
OUTPUT: 18 VDC; 2000 MA.

©2013 Gullane (Thomas) Limited

## ***Congratulations!***

**C**ongratulations on your purchase of the Lionel Thomas & Friends™ Ready-To-Run Remote Control Train Set!

This set includes everything you need to run your train, including a generous FasTrack loop that assembles in a flash. The power adapter plugs into the wall, and then connects directly to a special track section. Thomas is controlled using his very own blue Lionel remote. Go forward, reverse, or stop. Sound the whistle or bell — or have Sir Topham Hatt announce “All aboard!” at the press of a button. Thomas’ moving eyes ensure that your journey on everyone’s #1 engine is a safe one, and the removable roofs of Annie and Clarabel allow you to load and unload your passengers.

Use this Owner’s Manual to learn how to set up, operate, and maintain your train set for years of reliable operation.

**Parents!** **The wall-pack power supply included with this set should be periodically examined for conditions that may result in the risk of fire, electric shock, or injury to persons (such as damage to the output cord, blades, housing, or other parts). In the event that such conditions exist, the wall-pack power supply should not be used until properly repaired.**

### **Train Set Features**

---

- Electric locomotive controlled by remote
- Remote controller with forward and reverse speed control knob, whistle sound, bell sound, and “All aboard!” announcement (requires three AAA alkaline batteries, not included)
- Steam background sounds
- Moving eyes on locomotive
- Powerful maintenance-free motor
- Traction tire
- Operating coupler on rear of locomotive
- Dual operating couplers on coaches
- Set Length: 21”
- Layout Dimensions: 40” x 50”

# Table of contents

## **Creating your layout**

Operating your wall-pack power supply safely	4
Building your Lionel layout	5
Joining the FasTrack track sections	6

## **Powering your layout**

Connecting your wall-pack power supply	7
Installing AAA batteries into the Remote Control	8

## **Running your train**

Running your train set	9
Coupling	10
Attaching the three Thomas faces t	11
Operating your train with the Lionel Remote	12
Silencing the steam chuffing sounds	13

## **Maintaining and servicing your set**

Lubricating your locomotive	14
FCC Statement	15
Lionel Limited Warranty Policy & Service	16

*The following Lionel marks are used throughout this Owner's Manual and are protected under law. All rights reserved.*

*Lionel®*, *LEGACY™*, *FasTrack™*, *TrainMaster®*, *Odyssey®*, *RailSounds®*, *CrewTalk™*, *TowerCom™*, *DynaChuff™*, *StationSounds™*, *Pullmor®*, *ElectroCoupler™*, *Magne-Traction®*, *CAB-1® Remote Controller*, *American Flyer®*, *Lionel ZW®*, *ZW®*, *MagniVision®*, *TMCG®*, *Lionelville®*, *Wireless Tether™*, *Powerhouse™*, *LionMaster®*, *Conventional Classics™*, *Postwar Celebration Series™*, *TruRail™*, *PH-1 Powerhouse®*, *Powermaster®*, *Powerstation-Powerhouse®*, *Accessory Motor Controller™*, *AMC™*, *Accessory Switch Controller™*, *ASC™*, *Action Recorder Controller™*, *ARC™*, *Track Power Controller 300™*, *TPC 300™*, *Track Power Controller 400™*, *TPC 400™*, *Block Power Controller™*, *BPC™*, *Operating Track Controller™*, *OTC™*, *FatBoy™*, *Lionel Lines®*, *Joshua Lionel Cowen Series™*, *Lockon®*, *TrainSounds™*, *MultiHorn™*, *MultiWhistle™*, *Cboo-Cboo™*

## ***Creating your layout***

### **Operating your wall-pack power supply safely**

---

**Y**our Lionel wall-pack power supply is listed by Underwriter's Laboratory Inc. and has been carefully designed to ensure peak performance. When using electrical products, basic safety precautions should be maintained.

Be sure to observe the following guidelines:

- Read the manual thoroughly before using this device.
- This device is not recommended for children under eight years of age.
- Parents should periodically inspect this product for potential hazards and, if necessary, have them repaired by an authorized Lionel Service Center. In the event that such a condition exists, the wall-pack power supply should not be used until it has been properly repaired.
- The wall-pack power supply is intended to be used indoors. Do not use this device if water is present. Serious or fatal injuries may result.
- Use the wall-pack power supply only for its intended purpose.
- The wall-pack power supply was meant to operate on 120-240 volt AC, 50/60-Hertz power. Do not connect this product to any other power supply.
- Do not operate the wall-pack power supply with a damaged cord, plug, or case.
- To avoid the risk of electrical shock, do not disassemble the unit. There are no user serviceable parts inside. If damaged, take this product to an authorized Lionel Service Center. Visit [www.lionel.com](http://www.lionel.com) for a list of authorized Service Centers.
- Do not operate the wall-pack power supply on your layout unattended. Obstructed accessories or stalled trains may overheat, resulting in damage to your layout.
- Always unplug the wall-pack power supply from the power source when not in use.
- Never insert objects into the ventilation slots on this product. Damage to sensitive electronic components can result.

## ***Creating your layout***

### **Building your Lionel layout**

---

**Y**our set comes with eight curved sections, one 10" straight section, and one wall-pack terminal section of track. Figure 1 shows the oval layout that you can build with these track sections. You may choose to add more FasTrack track sections to create an endless number of exciting track arrangements for more fun, action, and variety.

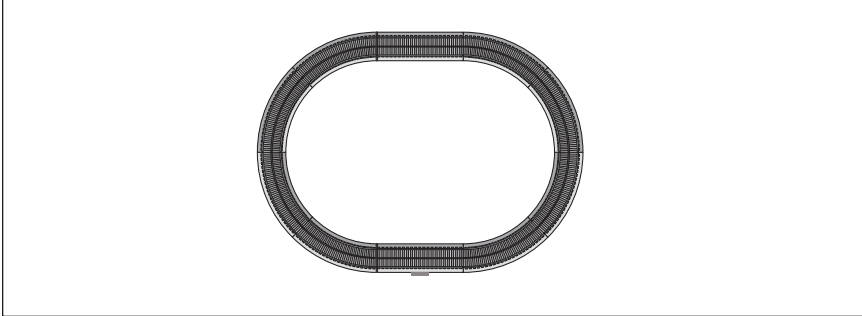

Figure 1. Track layout

## ***Creating your layout***

### **Joining the FasTrack track sections**

---

**F**asTrack track sections join together easily. With interlocking roadbed sections and large rail tabs, the track fits together securely so you always have good electrical contact. Take a look at Figure 2 to see how to join the track sections.

- 1. Line up your two sections of track.**
- 2. Insert the rail tabs into the openings at the ends of the corresponding rails.**
- 3. Press the sections together until the interlocking roadbed snaps into place.**

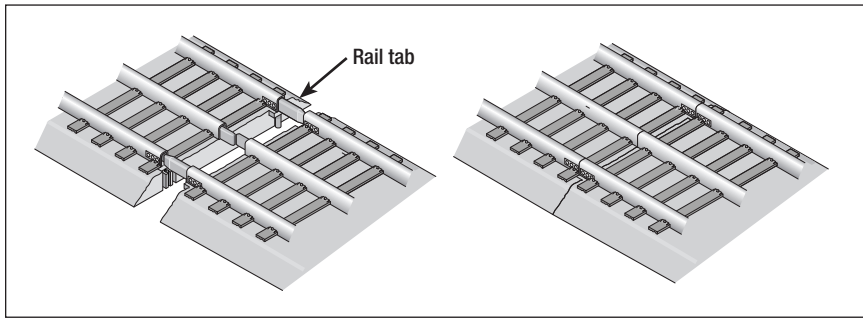

Figure 2. Joining the track sections

## ***Powering your layout***

### **Connecting your wall-pack power supply**

---

**Y**our trains are powered by a wall-pack power supply. To power the track, simply plug the wall-pack into an outlet and plug the jack into the terminal section as shown in Figure 3.

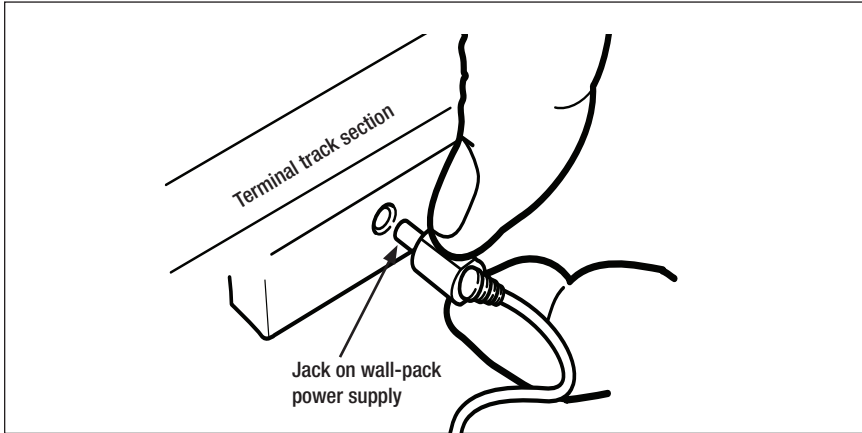

Figure 3. Wall-pack power supply connection

## ***Powering your layout***

### **Installing AAA batteries into the Remote Control**

---

**U**se a flathead screw driver to pry up the tab on the battery compartment hatch and lift the hatch to open battery compartment (as shown in Figure 4). Insert three AAA batteries orientating the +/- as shown in the bottom of the battery compartment. Replace the battery door and snap closed.

Use only Alkaline 'AAA' batteries. Use only new batteries. Never mix new and used batteries or use different types together.

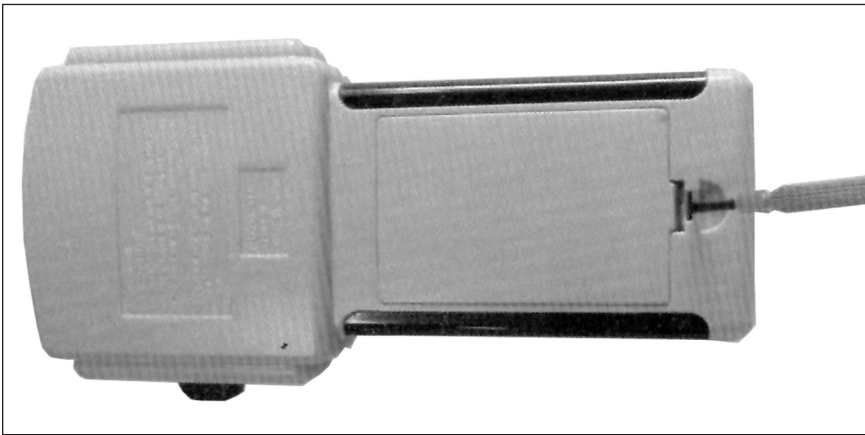

Figure 4. Opening and closing the battery compartment

**Important!** REMOVE ALL BATTERIES WHEN THE TRAIN WILL NOT BE USED FOR AN EXTENDED PERIOD OF TIME.



# ***Running your train***

## **Running your train set**

---

**1**

***With track power unplugged, place your train set on the track.***

Refer to the following section for information on coupling the cars.

**2**

***Plug in your wall-pack power supply and switch on the remote.***

**Your locomotive is designed to operate on 18 VDC or VAC.** You may choose to operate the train set using the wall-pack power supply, or you may run the locomotive on a layout powered by virtually any Lionel and Lionel-compatible alternating-current transformer.

**Note!**

Your locomotive is compatible with most direct-current (DC) and alternating-current (AC) transformers.

**3**

***Move 'em out!***

**Use your remote to run your train.** You can adjust the speed in forward or reverse, blow the whistle, sound the bell, or trigger an announcement. Refer to page 12 for complete details.

**Note!**

If your remote control is switched Off while the locomotive is still running, the locomotive will automatically come to a stop in 10 minutes. To restart the locomotive, simply unplug the power cord at the terminal section for a few moments, and then restore power to cycle the locomotive back to normal operation. If you are done operating your trains, be sure to unplug the wall-pack power supply from the outlet.

**4**

***Unplug the wall-pack power supply when you are done running your trains.***

Switch the remote control off to conserve the batteries.

## ***Running your train***

### **Coupling**

---

**W**hen coupling your cars, at least one of the mating couplers must be open as shown at the left in Figure 5. Press down on the lock release to open the coupler, then push the cars toward each other until they lock together.

**Note!** Keep in mind that it's easier to couple cars on a straight stretch of track.

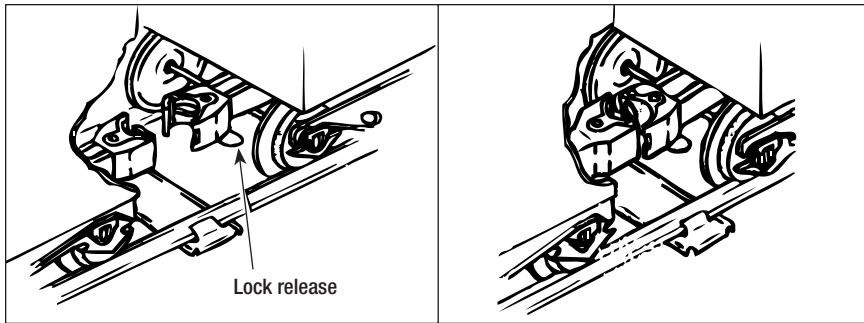

Figure 5. Coupler operation

## ***Running your train***

### **Attaching the three Thomas faces**

---

**T**hree interchangeable facial expressions (surprised, tired and angry) easily slip on and off Thomas for fun and imaginative play. Refer to Figure 6.

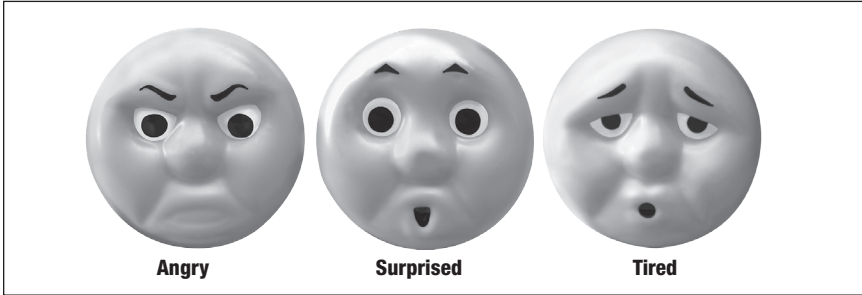

Figure 6. Interchangeable faces

**T**o attach one of the faces, carefully position it in front of the permanent smiling Thomas face and push it straight on. To remove it, simply pull it straight off. Please remember that the smiling Thomas face cannot be removed. Refer to Figure 7.

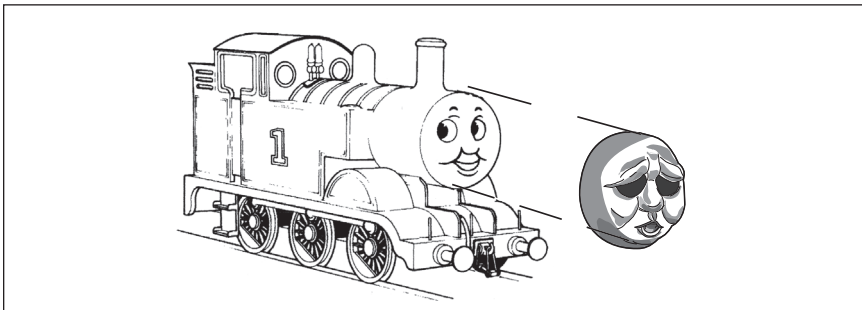

Figure 7. Face installation

# Running your train

## Operating your train with your Lionel Remote

---

### **THROTTLE**

Turn the throttle knob clockwise to go forward and adjust the speed. Turn the throttle knob counter-clockwise to go reverse and adjust the speed. To stop the train, simply return the throttle knob to the center position.

### **BELL**

The BELL button will activate the bell sounds on locomotives equipped with this feature. Press the BELL button to begin the sounds; press the button again to turn off the ringing.



### **SPEED INDICATOR LIGHT**

The red light will remain on during normal operation. The light will begin to flash when the locomotive is in motion, and the flashing will vary with the locomotive's speed.

### **WHISTLE**

The WHISTLE button will activate your locomotive's whistle.

### **ANNOUNCEMENT**

Press the center button for an "All aboard!" announcement.



### **ON/OFF SWITCH**

To conserve your batteries, slide the On/Off switch to the Off position when you are done operating your train.

## ***Running your train***

### **Silencing the steam chuffing sounds**

---

**T**o silence the steam chuffing sounds, simply lift off Thomas' cab roof and slide the CHUFF switch to the OFF position. See Figure 9. Turn off track power for about two seconds, and then the steam chuffing sound will be silenced when the track power is restored. The whistle, announcement, and bell sounds can still be triggered at any time using the remote. To restore the steam chuffing sounds, simply slide the CHUFF switch to the ON position and then briefly turn off track power.

**Note!** Always turn off track power for about two seconds after you slide the switch. The sounds will be reset according to the new switch position when the track power is switched on again.

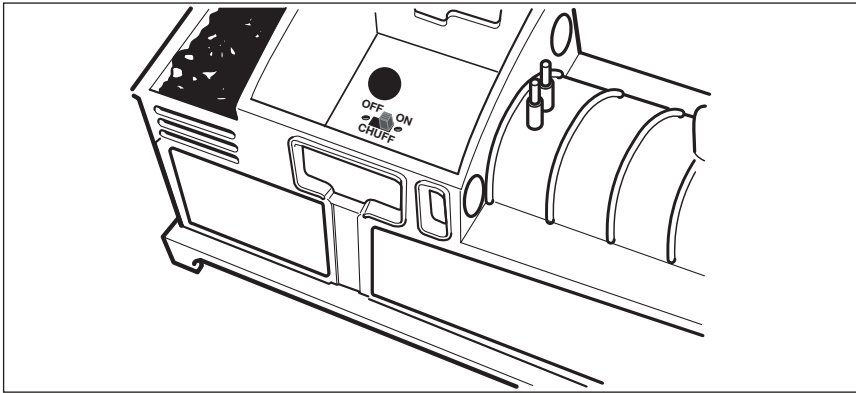

Figure 9. Sound switch location

# Maintaining and servicing your set

## Lubricating your locomotive

**H**elp your steam locomotive lead a long and productive life on your railroad by maintaining it properly.

We recommend that you purchase a Lionel Lubrication and Maintenance Kit (6-62927), available from your Lionel dealer. Two basic rules to keep in mind: never over-lubricate (a small amount will do) and avoid getting grease or oil on the locomotive's wheels, contact rollers, or your track.

You'll know your locomotive requires lubrication when visual inspection reveals dryness on the parts indicated in Figure 10. Remove accumulated dirt and dust before lubricating, and always lubricate any locomotive emerging from prolonged storage.

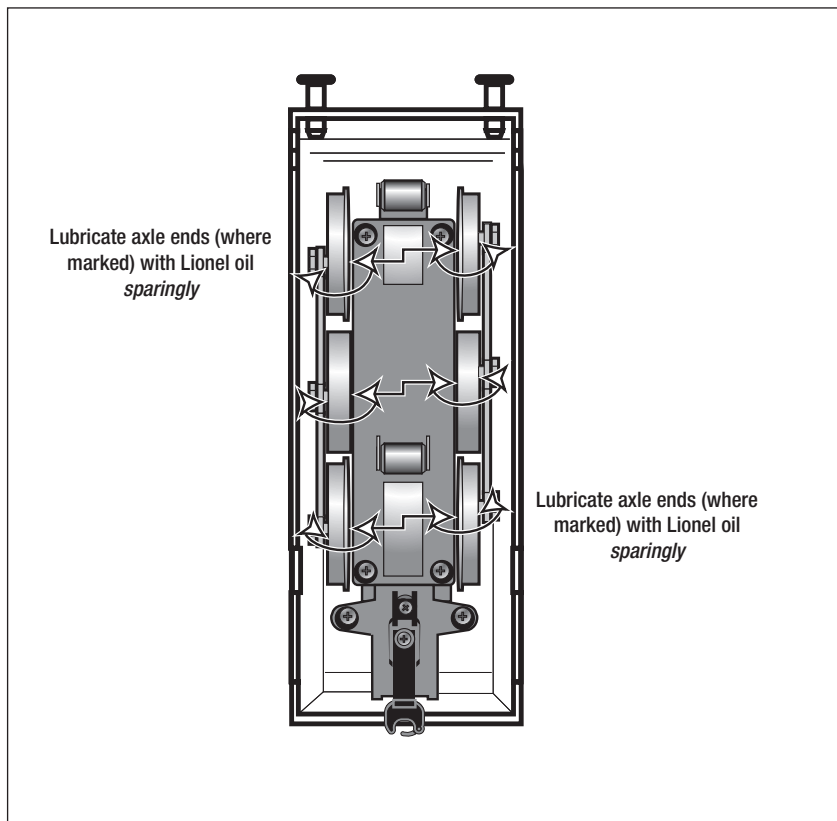

Figure 10. Lubrication points

# ***Maintaining and servicing your set***

## **FCC Statement**

---

Warning: Changes or modifications to this unit not expressly approved by the party responsible for compliance could void the user authority to operate the equipment.

.....

Notes: This equipment has been tested and found to comply with the limits for a Class B digital device, pursuant to Part 15 of the FCC Rules. These limits are designed to provide reasonable protection against harmful interference in a residential installation. This equipment generates, uses and can radiate radio frequency energy and, if not installed and used in accordance with the instructions, may cause harmful interference to radio communications.

However, there is no guarantee that interference will not occur in a particular installation. If this equipment does cause harmful interference to radio or television reception, which can be determined by turning the equipment off and on, the user is encouraged to try to correct the interference by one or more of the following measures:

- Reorient or relocate the receiving antenna.
- Increase the separation between the equipment and receiver.
- Connect the equipment into an outlet on a circuit different from that to which the receiver is connected.
- Consult the dealer or an experienced radio/TV technician for help.

## Lionel Limited Warranty Policy & Service

---

This Lionel product, including all mechanical and electrical components, moving parts, motors and structural components, with the exception of **LIGHT BULBS, LED's & TRACTION TIRES** are warranted to the original owner-purchaser for a period of **one year from the original date of purchase** against original defects in materials or workmanship when purchased through a **Lionel Authorized Retailer\***.

This warranty does **NOT** cover the following:

- Normal wear and tear
- Light bulbs or LED's
- Defects appearing in the course of commercial use
- Damage resulting from abuse/misuse of the product

Transfer of this product by the original owner-purchaser to another person voids this warranty in its entirety. Modification of this product in any way; visually mechanically or electronically, voids the warranty in its entirety.

Any warranted product which is defective in original materials or workmanship and is delivered by the **original owner-purchaser** (this warranty is non-transferrable) to Lionel LLC or any Lionel Authorized Service Station **MUST** be accompanied by the original receipt for purchase (or copy) from an **Authorized Lionel Retailer\***, will at the discretion of Lionel LLC, be repaired or replaced, without charge for parts or labor. In the event the defective product cannot be repaired, and a suitable replacement is not available, Lionel will offer to replace the product with a comparable model (**determined by Lionel LLC**), if available. In the event a comparable model is not available the customer will be refunded the original purchase price (requires proof of purchase from the **Authorized Lionel Retailer\*** it was originally purchased). Any products on which warranty service is sought must be sent freight or postage prepaid (Lionel will refuse any package when postage is due).

**Transportation and shipping charges are not covered as part of this warranty.**

**NOTE: Products that require service that do not have a receipt from an LIONEL AUTHORIZED RETAILER\* will be required to pay for all parts required to repair the product (labor will not incur a charge) providing the product is not older than 3 years from date of manufacture and is within 1 year from date of purchase. A copy of the original sales receipt is required.**

**In no event shall Lionel LLC be held liable for incidental or consequential damages.**

---

Some states do not allow the exclusion or limitation of incidental or consequential damages, so the above exclusion may not apply to you.

This warranty gives you specific legal rights and you may have other rights which vary from state to state.

### Instructions for Obtaining Service

---

If service for this Lionel LLC product is required; bring the item, along with your DATED sales receipt and completed warranty information (at the bottom of this page) to the nearest Lionel Authorized Service Station. Your nearest Lionel Service Station can be found by calling 1-800-4-LIONEL or by accessing the website at [www.lionel.com](http://www.lionel.com).

If you prefer to send your Lionel product directly to Lionel, for repair you must FIRST call 586-949-4100 extension 9105 or FAX Lionel at 586-949-5429 or write to Customer Service, 6301 Performance Drive, Concord, NC 28027. Please have the 6-digit Lionel product number, the date of original purchase, the dealer where the item was purchased and what seems to be the problem. You will receive a return authorization (RA) number to ensure your merchandise will be properly tracked and handled upon receipt at Lionel LLC.

Once you have your Return Authorization (RA) number, make sure the item is packed in its original Styrofoam inner container which is placed inside the original outer display box (this will help prevent damage during shipping and handling). This shipment **MUST** be prepaid and we recommend that it be insured with the carrier of your choice.

Please make sure you have followed all of the above instructions carefully before returning any merchandise for service. You may choose to have your product repaired by one of Lionel LLC's Authorized Service Stations after its warranty has expired. A reasonable service fee should be expected once the product warranty has expired.

### Warranty Information

---

Please complete the information below and keep it, along with your **DATED ORIGINAL SALES RECEIPT**. You **MUST** present this form **AND** your **DATED SALES RECEIPT** when requesting warranty service.

\*A complete listing of Lionel Authorized retailers can be found by calling 1-800-4-LIONEL or by visiting our website at [www.lionel.com](http://www.lionel.com).

Products that are more than 3 years old, from date of manufacture, are not applicable for warranty coverage, even if they have never been sold prior to this date. (Under no circumstance shall any components or labor be provided free of charge.)

Name \_\_\_\_\_

Address \_\_\_\_\_

Place of Purchase \_\_\_\_\_

Date of Purchase \_\_\_\_\_

Product Number \_\_\_\_\_

Product Description \_\_\_\_\_



©2013 LIONEL L.L.C., CONCORD, NC 28027  
UNITED STATES OF AMERICA  
PRINTED IN CHINA