

LSI

Load Systems International

Manufacturers of Wireless
Weighing Systems

GS320 Display & Wind Speed Sensor

INSTALLER AND USER'S MANUAL

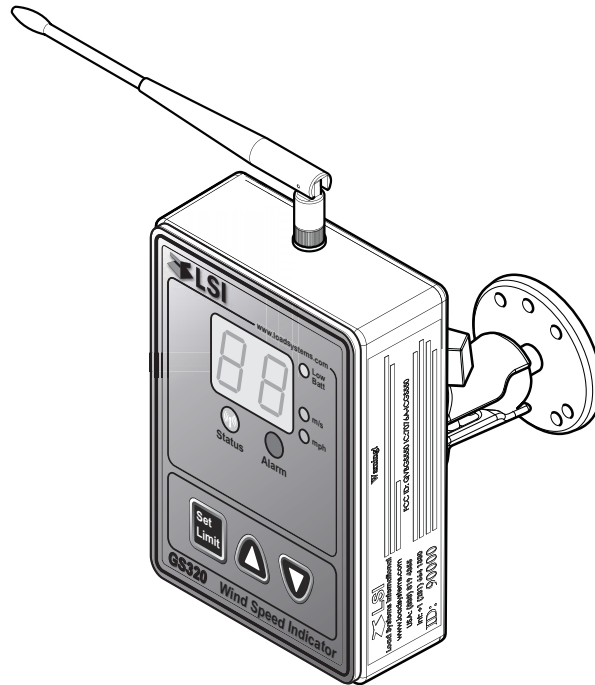

WARNING! The GS320 system is designed as an operator aid and is in no way a substitute for safe operating practice.



WARNING! Carefully read and understand this manual before proceeding.



BEFORE PROCEEDING

Read and understand the following:

For your safety and that of the people that come into contact with **LSI** products, understand the significance of the instructions included in this guide, respect all laws and regulations and comply with applicable standards.

Pay particular attention to items bearing the alert symbol  and the following words:



WARNING!

Warning: this denotes an instruction that if not complied with may lead to serious injury or death.



CAUTION!

Caution: this denotes an instruction that if not complied with may lead to product failure or property damage.



IMPORTANT!

Important: this denotes an instruction that if not complied with may lead to product performance issues.



WARNING! Installation must be made in compliance with **LSI** instructions and using supplied components only. Failure to install all parts, or replacing parts or components with parts or components not supplied by **LSI**, may lead to system failure, serious injury or death.

TABLE OF CONTENTS

1. INTRODUCTION		6. LSI PRODUCT LIMITED WARRANTY - 2009/02/16	
1.1 OVERVIEW	4	6.1 LIMITED WARRANTY	12
1.2 START-UP	4	6.2 WARRANTY SERVICES PROCEDURES.....	12
1.3 RECOMMENDED OPERATING CONDITIONS	4	6.3 EXCLUSION OF OTHER WARRANTIES	12
2. INSTALLATION		6.4 EXCLUSION	13
2.1 DISPLAY GS320.....	5	6.5 LIMITATION OF LIABILITY	13
2.1a Mounting Bracket.....	5	6.6 RECOMMENDED PRACTICES	13
2.1b Antenna Position	6	6.7 CHOICE OF LAW	13
2.1c Power Supply and Lockout Connection.....	6	6.7a Entire Agreement	13
2.2 WIRELESS WIND SPEED SENSOR GS020	7		
3. OPERATION			
3.1 UNITS	8		
3.2 ALARM THRESHOLD	8		
3.3 LISTEN ONLY MODE	8		
3.4 DISPLAY SETTINGS	8		
4. MAINTENANCE			
4.1 REPLACING THE SENSOR BATTERY	9		
4.2 REPLACING THE SENSOR ANTENNA.....	10		
5. CERTIFICATION NOTES			
5.1 FCC AND IC – INSTRUCTIONS TO THE USER	11		

1. INTRODUCTION

1.1 Overview

The wind speed indicator kit includes a GS320 display and a wind speed sensor. The GS320 creates a two-way radio network with the wind speed sensor to bring live readings on screen. The GS320 has a user adjustable maximum wind speed limit and will generate an alarm when this limit is reached. Furthermore, when in alarm voltage is generated on the green wire; this can be used to activate a remote siren, light or lockout function.

1.2 Start-Up

On power up, the display will show two horizontal lines and the green status light will flash.



Once a reliable radio communication network is established, the display lights will remain lit without flashing.

If the status light flashes continuously for more than 30 seconds the GS320 may not be correctly programmed for the wind speed sensor. To correctly program the GS320 for the wind speed sensor follow the **Wind speed ID number** procedure in the **Operation** section of this manual.

1.3 Recommended Operating Conditions

Supply voltage:

9 to 30 volts

Current requirements:

maximum 1 amperes

Output wire voltage:

0 volts or supply voltage - 0.7 volts

Output wire current capability:

0.75 amperes

Operating temperature:

-40°C to +85°C (-40°F to 185°F)

2. INSTALLATION

WARNING! Installation must be made in compliance with **LSI** instructions and using supplied components only. Failure to install all parts, or replacing parts or components with parts or components not supplied by **LSI**, may lead to system failure, serious injury or death.

2.1 Display GS320

IMPORTANT! Do not crack or puncture the membrane fascia. The GS320 display is splash and rain proof. Waterproofing depends in part on the integrity of the membrane.

IMPORTANT! Do not power wash the display. The GS320 display is not designed to withstand high-pressure washing devices that can erode the membrane fascia seal or create fissures in the membrane fascia. Power washing the display voids warranty coverage.

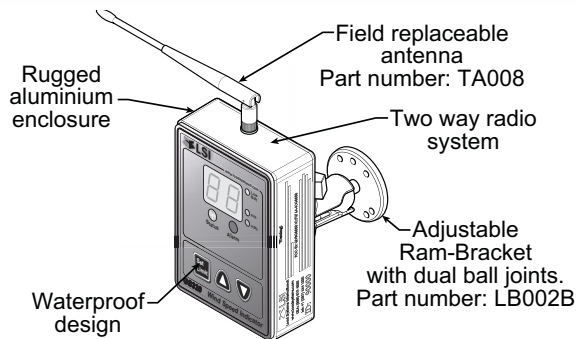

Figure: Display GS320

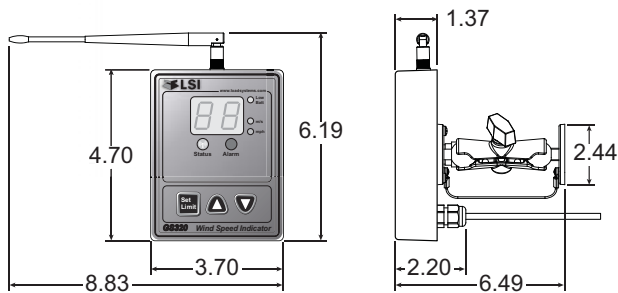

Figure: Display dimensions (inches). Not to scale.

2.1a Mounting Bracket

1. Determine the mounting location; the display may be installed either inside or outside the cab. It can be mounted on the dash, on a sidewall, or on the ceiling of the cab. **To ensure**

reliable radio communication between wind speed sensor and the GS320, the antenna should not be in contact with metal and should have a direct and clear line of sight to the sensor antenna. The mounting bracket requires a flat surface of at least 2.5 inches in diameter on both sides and where the back of the surface is accessible in order to tighten the nuts.

2. Drill 1/4 inch boltholes through the mounting surface with a 1/4 inch bit following either the two, three, or the four holes configuration.

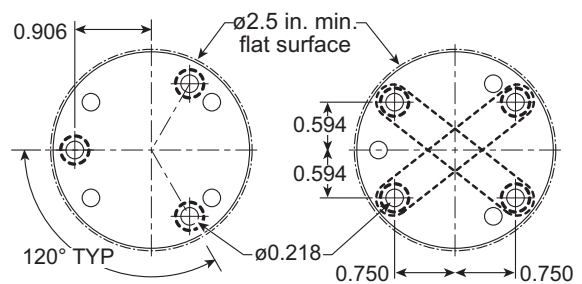

Figure: Display mounting bracket footprint. Not to scale.

3. Install the display with bolts. Add washers and lock nut behind the mounting surface and tighten sufficiently (bolts, nuts and washers not included).

Note: If the nuts are on the outside of the cab, caulk with silicone between the washers and the cab to prevent water entry.

4. Loosen the wing nut of the bracket arm to adjust display orientation to facilitate viewing by the operator and then tighten it back up.

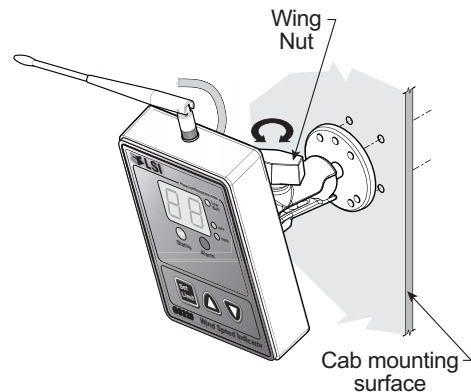

Figure: Install the display and adjust orientation

2.1b Antenna Position

For optimal performance the antenna should be positioned on its side such that it is parallel to the sensor antenna (but not pointing directly to or directly away from it).

1. Adjust the antenna position with the articulating base.
2. The antenna should have 5 inches of clear space all around it.
3. The antenna should have an unobstructed line of sight to all sensor antennas at all boom angles.

2.1c Power Supply and Lockout Connection

1. Connect the blue wire (ground) to the negative terminal of the battery or the panel connection; alternatively bolt the blue wire to the body of the machine with a 1/4 inch or 5/16 inch bolt. The ground connection must be strong enough to sustain 3 amperes.
2. Connect the red wire to a fused accessory source, rated at least 3 amperes, that supplies +12 or +24 volts when the machine is in use. The GS320 will automatically detect the voltage level and adjust itself.
3. Lockout wire (if required): connect the green wire to a Bosch relay coil terminal. Connect the other coil terminal of the relay to the ground.

Current over 1 ampere on the green wire triggers an auto re-settable fuse. Current flow will resume several seconds after the short circuit is eliminated.

Troubleshooting: if no voltage is present on the green wire remove the load connected to it.

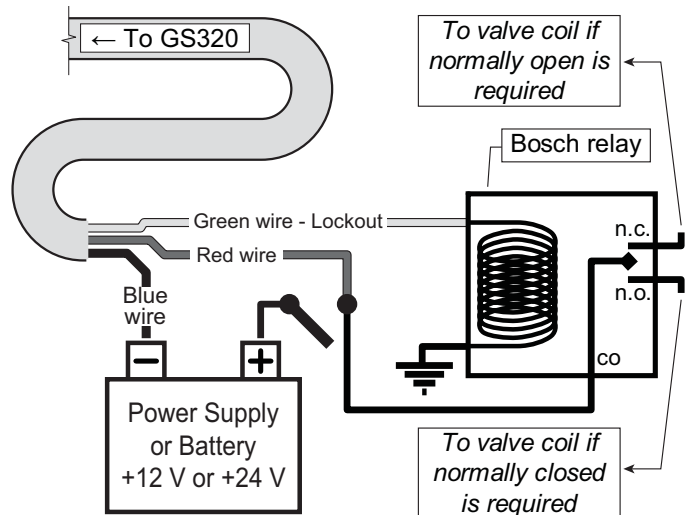

Figure: Connection with green wire lockout and recommended Bosch relay.

2.2 Wireless Wind Speed Sensor GS020

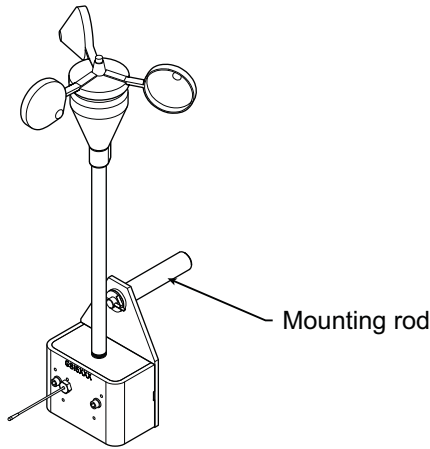

Figure: GS020 wireless wind speed sensor

1. Remove the mounting rod from the wind speed sensor.

IMPORTANT! Do not weld in proximity to LSI sensor/transmitters.

2. Determine the mounting rod position.
 - a. Install the mounting rod on the same side of the boom as the cabin mounted display, perpendicular to the boom, and at the highest point possible.
 - b. The wind speed sensor must pivot freely on the mounting rod at all boom angles.

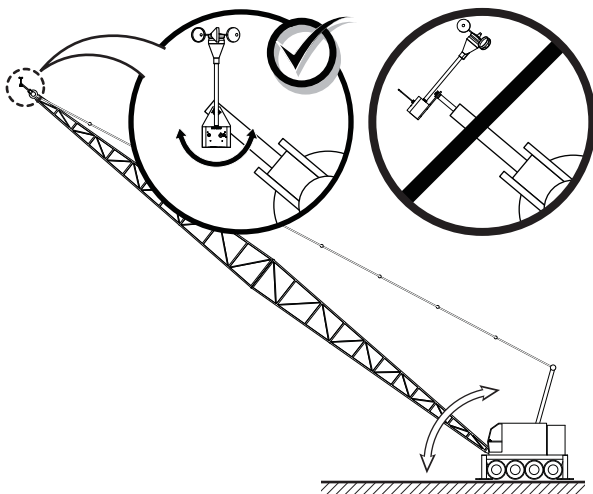

Figure: Swivel orientation

- c. The wind cups must be fully exposed to the wind and spin freely at all boom angles.

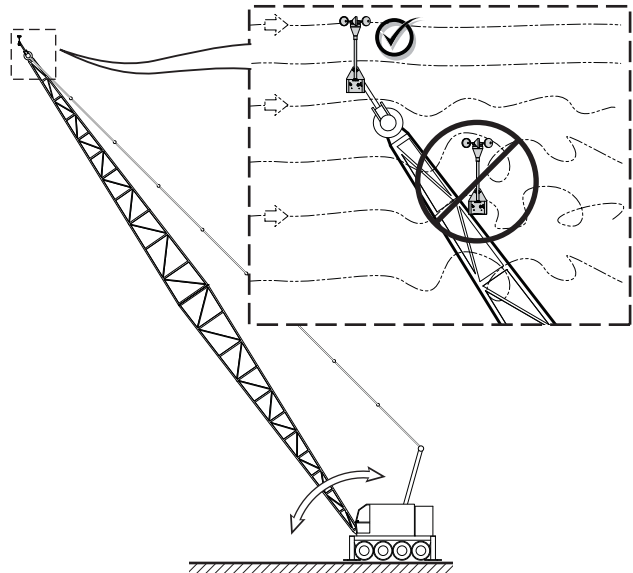

Figure: Wind clearance

- d. There should be a clear and unobstructed line of sight between the wind speed sensor antenna and the cabin mounted display unit.

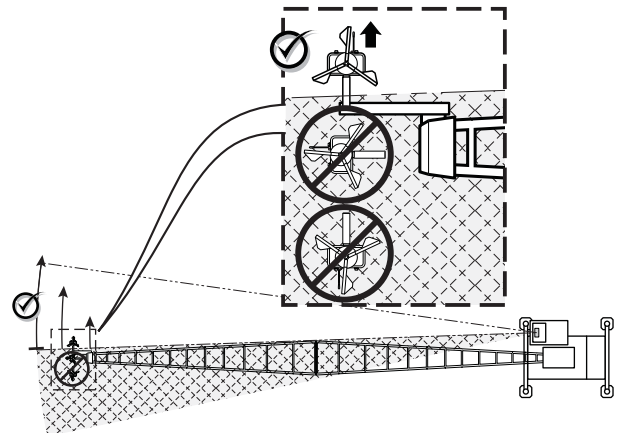

Figure: Radio line of sight - Crane top view

- e. The transmitter antenna should not contact any metal object.

Note: Angle iron can be used to extend the mounting position to be clear of the boom top.

3. Weld or screw the mounting rod to the boom at the selected position.
4. Re-position the wind speed sensor on the mounting rod, add the washer and secure with the cotter pin.

3. OPERATION

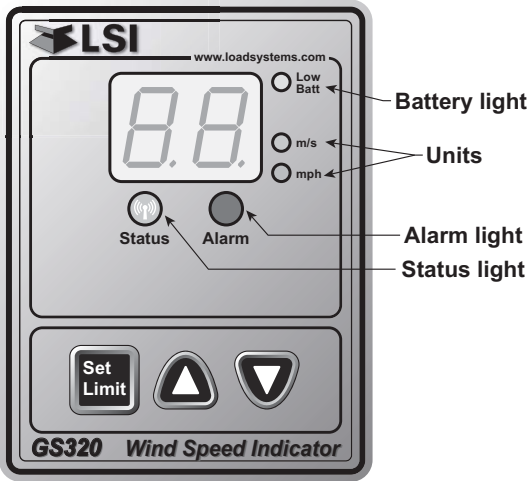

3.1 Units

The GS320 indicates wind speed in miles per hour (mph) or metres per second (m/s). Current units are indicated by a small green light.

To change units press and hold the **Down** button for 5 seconds. Verify the alarm threshold every time the current units are changed.

3.2 Alarm Threshold

Press the **Set Limit** button to see the alarm threshold. **Every time the units are changed, the limit must be verified and re-adjusted if required.**

To change the limit, press and hold down the **Set Limit** button, and use the **Up** or **Down** buttons repeatedly to increase or lower the limit.

3.3 Listen Only Mode

When the GS320 is started it wakes up the wind speed sensor programmed to it and takes control of the sensor. This means that if a second display is programmed for the sensor, it will take control of it; the sensor will no longer acknowledge communication from the first display. The GS320 can be programmed to operate in “listening mode”. In this mode the GS320 will display information from the programmed sensor without becoming the network controller.

IMPORTANT! A sensor can only have one network controller at a time. To receive communication from a sensor without taking control of that sensor the display must first be programmed in “listening mode”.

3.4 Display Settings

This section describes how to manually change the ID number the GS320 will listen to, and how to change some other behavior of this display. Changing the wind speed ID number is required only if the wind speed sensor is changed and the display must be manually set to listen to an other one.

Press and hold the **Up** and **Down** buttons simultaneously for 5 seconds. The display will beep and then indicate the currently programmed wind speed sensor ID number, one digit at a time. The ID number must contain 6 digits, if the ID number is 120, the three first digits are “000”.

1. Press **Set Limit** button to change from one screen to the next.
2. To change a digit, use the **Up** and **Down** buttons.

LD “LD” means *Listening De-activated* (default). Press **Down** to change to “LA”.

LA “LA” means *Listening Mode Active*. Another GS320 display must be the master of the wind speed sensor.

OS “OS” means *Output Standard: fail safe output* (default). The output provides power when wind speed is safe, below the limit. Press **Down** to change to “OI”.

OI “OI” means *Output Inverted*: the output wire is energized when wind speed is above the limit. This could be use to power an external siren or horn.

SA “SA” means *Save*. When this screen is displayed, press the **Down** button to save the ID number and above options and then exit.

CA “CA” means *Cancel*. Press the **Down** button to exit without saving. The system will retain the previously set ID number and options.

Example: if the ID number is 18820, it will appear like this on the screen:

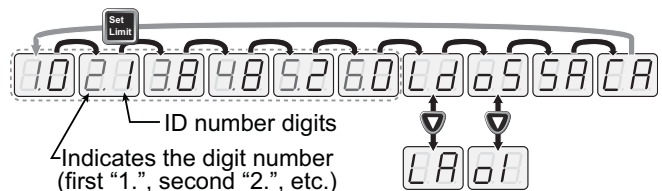

Figure: Example ID number 18820

4. MAINTENANCE

4.1 Replacing the Sensor Battery

IMPORTANT! Protect the interior of the sensor from dirt and humidity at all times.

1. Unscrew the two allen screws about a quarter of an inch.
2. Insert a flat bladed screwdriver in the battery cover notch to pry the box away from the mounting plate. The silicone seal may cause some resistance.

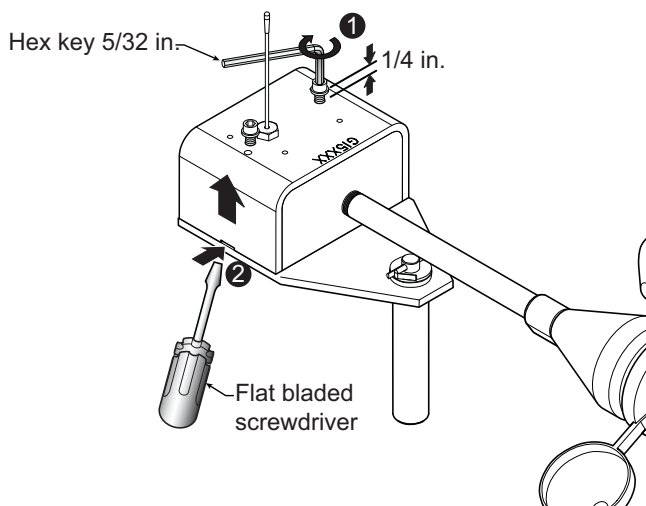

Figure: Remove the sensor box from the mounting plate

4. Remove the battery by hand.
5. Remove the remaining silicone from both the box and the mounting plate.
6. Install the new battery: insert the positive end and then push in the direction of the positive pole.

New high quality "D" cell battery: 3.6 V lithium, or alkaline

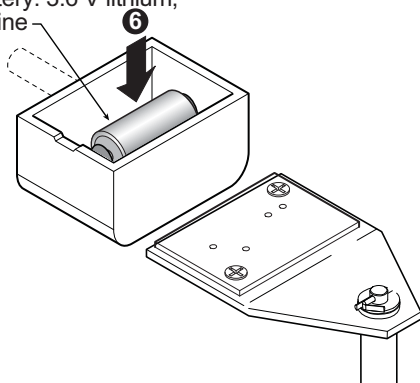

Figure: Install the new battery

Note: A 3.6 volt lithium "D" cell battery will provide about two years of battery life, while an alkaline "D" cell battery will provide less than one year of battery life*.

8. Apply a non-corrosive RTV silicone all around the edge of the mounting plate to create a new seal without bubbles or breaks.

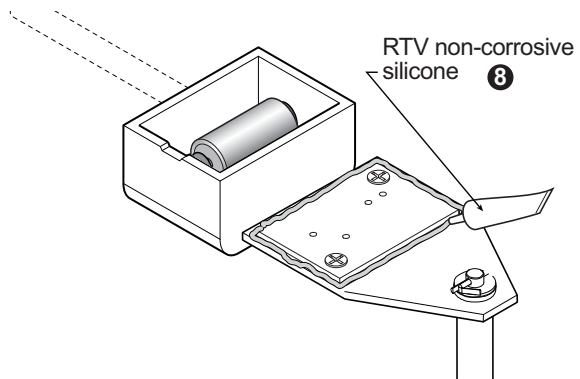

Figure: Apply non-corrosive RTV silicone

9. Reposition the box over the mounting plate and screw in the hex screws. **Do not over-tighten.**

* Actual battery life will vary greatly depending on the application, the frequency of use, the age and quality of the battery etc.

4.2 Replacing the Sensor Antenna

Heavily damaged antennas (ripped out, sheared off, wire exposed and fraying etc.) should be replaced to ensure effective communication between the sensor and the cabin mounted display unit.

This procedure may be followed without removing the sensor from the crane if it is safe to do so.



IMPORTANT! The interior of the sensor must be protected from dust, grime and water at all times.

1. Place the crane, boom, jib or ball hook such that the sensor is safely accessible.
2. Clean dust, grime and water from the sensor.
3. Identify the short black whip antenna and the white hex bolt securing it.
4. Inspect the antenna for signs of obvious physical damage.
5. Carefully unscrew the white nylon hex bolt completely and slide it up the antenna.

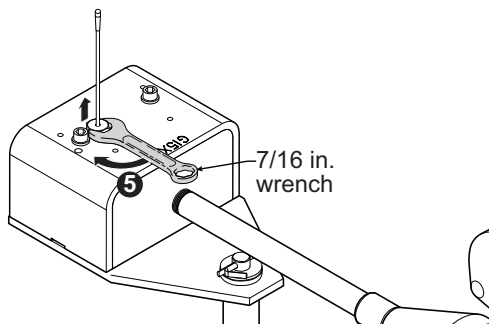

Figure: Unscrew the white nylon hex

6. Grip the antenna by the base of the black plastic sheathing and pull it straight out of the hole in which it is seated. Place the old antenna aside.

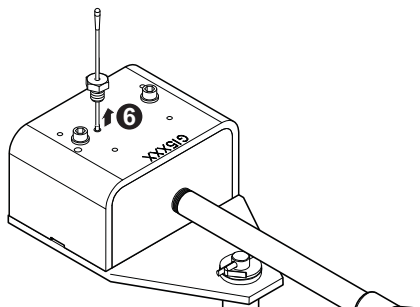

Figure: Pull out the antenna

7. Slide the white nylon hex bolt to the middle of the length of the new antenna.
8. Coat the exposed metal foot of the new antenna with an electrical insulating compound by carefully inserting it in the mouth of the compound tube.

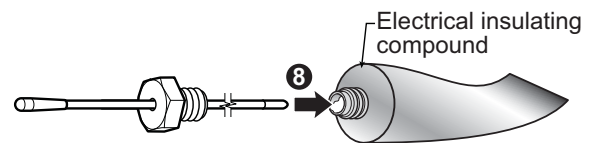

Figure: Coat the exposed metal foot of the antenna

9. Hold the new antenna by the black plastic sheathing and guide it through the hole in the sensor box. Carefully seat the antenna in its mating connector. When the antenna is correctly seated, pulling on it will be met with light resistance.

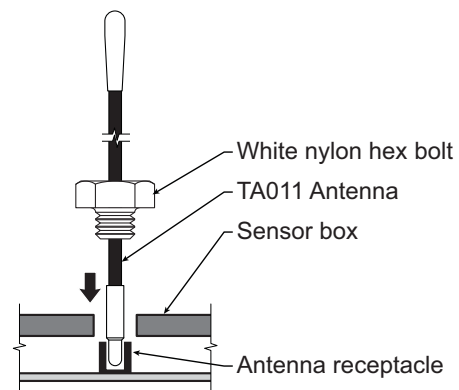

Figure: Install the new antenna

10. Carefully re-thread, screw-in and tighten the white nylon hex bolt to secure the antenna in place. **Do not overtighten.**
11. Reinstall the sensor if necessary.
12. Verify that the sensor functions properly.

5. CERTIFICATION NOTES

5.1 FCC and IC – Instructions to the User

This equipment has been tested and found to comply with the limits for a class B digital device, pursuant to part 15 of the FCC Rules. These limits are designed to provide reasonable protection against harmful interference in a residential installation. This equipment generates, uses, and can radiate radio frequency energy and if not installed and used in accordance with the instructions, may cause harmful interference to radio communications. However, there is no guarantee that interference will not occur in a particular installation. If this equipment does cause harmful interference to radio or television reception, which can be determined by turning the equipment off and on, the user is encouraged to try to correct the interference by one or more of the following measures:

- Reorient or relocate the receiving antenna.
- Increase the separation between the equipment and receiver.
- Connect the equipment into an outlet on a circuit different from that to which the receiver is connected.
- Consult the dealer or an experienced radio/TV technician for help.

In order to maintain compliance with FCC regulations, shielded cables must be used with this equipment. Operation with non-approved equipment or unshielded cables is likely to result in interference to radio and TV reception.

 **IMPORTANT!** Changes or modifications to this equipment not expressly approved by the party responsible for compliance could void the user's authority to operate the equipment.

FCC ID: QVBGS300 IC: 7076A-ICGS300

RF Exposure Warning:

This product complies with FCC/IC radiation exposure limits set forth for an uncontrolled environment. To comply with RF exposure requirements, the unit must be installed and operated with 20 cm (8 in.) or more between the product and your body. This product may not be

collocated or operated in conjunction with any other antenna or transmitter.

This device has been designed to operate with the antennas listed below, and having a maximum gain of 2.0 dB. Antennas not included in this list or having a gain greater than 2.0 dB are strictly prohibited for use with this device. The required antenna impedance is 50 ohms.

To reduce potential radio interference to other users, the antenna type and its gain should be so chosen that the equivalent isotropically radiated power (e.i.r.p.) is not more than that permitted for successful communication.

Antenna List

LSI P/N:TA008

Description: .1/2 wave dipole

MFG:Nearson

P/N:S467AH-915S

6. LSI PRODUCT LIMITED WARRANTY - 2009/02/16

6.1 Limited Warranty

LOAD SYSTEMS INTERNATIONAL INC. (hereafter "**LSI**") warrants its products (the "Products"), for a period of twenty four (24) consecutive months after delivery of such Products to the user (as evidenced on a **LSI** document) (the "Warranty Period"), when installed and used in accordance with specifications described in **LSI** Installer and User's Manual, as amended from time to time, **LSI** technical materials and any related writings published by **LSI** with respect with such Products and any industry standards, will be free from defects in materials and workmanship. During the Warranty Period, **LSI** or its designated service representative shall repair, or at its option, replace any Product that is confirmed to be defective by **LSI**, in its sole discretion, in accordance with the Limited Warranty Services Procedures described below.

6.2 Warranty Services Procedures

In order to benefit of this-mentioned Limited Warranty coverages and benefits, the purchaser must notify **LSI**'s customer service or **LSI**'s authorized distributor or representative originally responsible for the sale of the Products within 10 days of the occurrence of a suspected defect in materials or workmanship, prior to the expiry of the Limited Warranty Period in order to obtain a Return Authorization Number. A proof of purchase of the Product, such as an invoice or a receipt certifying the validity of the Warranty, must be presented in order to obtain Limited Warranty coverage. In any event, even if a Return Authorization Number is provided to purchaser, **LSI** reserves the right to inspect the damaged Product or part before the final decision of repairing or replacing the defective Product or part.

The Product or part shall be returned to **LSI** or its designated service representative, accompanied by the Return Authorization Number with prepaid shipping charges. The purchaser must insure the shipment or accept the risk of loss or damage during the shipment. Purchaser shall also pay any tariff or duty applicable to the return of defective part or Product. **LSI** will, at its option, repair or replace the Product or part returned to **LSI** or to its designated service representative. **LSI** owns all parts or Products replaced, repaired or removed from a repaired Product. If **LSI** repairs a Product, the Product

Warranty coverage Period is not extended and the Limited Warranty shall expire as if uninterrupted upon the occurrence of the 24th month from shipping from **LSI**. If **LSI** replaces a Product, the replaced Product is warranted for the remainder of the original term or sixty consecutive (60) days, whichever is longer.

LSI reserves the right to require from you the user or owner of the Products, prior to determining if the Limited Warranty coverage is applicable, that **LSI** receive the data logging equipment used with the Products and that **LSI** be authorized to retrieve all information from such data logging equipment in order to, among others, ensure that the written instructions and applicable standards, including safety margins, were respected and not exceeded during Product use. Failure by you the owner or user of the Product to supply such information shall be deemed a material default of the terms and conditions of this Limited Warranty and shall be irrevocably construed as evidence that the Product was misused or abused. Consequently **LSI** shall irrevocably be relieved of any obligations to compensate you the user or owner of the Product for any and all damages resulting from Product failures when data logging equipment, and access to its content, cannot be freely and readily provided, unhampered, to **LSI**.

LSI will pay ground freight transportation costs of replacement or repaired parts or Products to the destination in Canada and the continental United States of America (the "Territory"). LSI will not pay any transportation costs of replacement or repaired parts to destination outside of the Territory. Shipping and handling costs to locations outside the Territory shall be the responsibility and borne by Purchaser or Owner of the Product prior to any shipment by LSI. (Contact LSI to get a Return Authorization Number and the address to ship parts).

6.3 Exclusion of Other Warranties

THE ABOVE WARRANTY IS THE SOLE WARRANTY APPLICABLE AND THERE ARE NO EXPRESS, LEGAL OR IMPLIED WARRANTIES OR CONDITIONS IN RELATION TO ANY PRODUCTS INCLUDING ANY IMPLIED WARRANTY OR CONDITION OF MERCHANTABILITY, NON-INFRINGEMENT OR FITNESS FOR A PARTICULAR PURPOSE AND THOSE OTHERWISE ARISING BY STATUTE OR OTHERWISE IN LAW OR FROM A COURSE OF

DEALING OR USAGE OF TRADE, WHICH ARE EXPRESSLY DISCLAIMED. NO ORAL OR WRITTEN INFORMATION OR ADVICE GIVEN BY *LSI* OR ITS EMPLOYEES OR REPRESENTATIVES SHALL CREATE A WARRANTY OR CONDITION OR IN ANY WAY INCREASE THE SCOPE OF *LSI*'S OBLIGATION. *LSI* DOES NOT WARRANT THAT THE BUSINESS RESULTS OBTAINED FROM THE USE OF THE PRODUCTS WILL BE APPROPRIATE OR ADEQUATE FOR THE PURCHASER.

6.4 Exclusion

This Limited Warranty does not cover and shall not apply to:

- Any Product that is misused or abused, including being altered, modified or repaired not in accordance to *LSI* written instructions or authorizations and any use not in compliance with *LSI*'s instructions and/or industry standards and practices;
- Any incidental costs or expense, such as shipping charges to *LSI* or an designated service representative as well as the technician out-of-pocket expenses including traveling, lodging and meal expenses, if any;
- The damages caused during the transport or the moving of the Products;
- Damages caused by accidents, abuse, misuse, a force majeure (described as events outside a *LSI*'s or any Product user's control, including war, riot, strikes, embargoes) or external cause;
- Any cost, damage or expenses for field labor or any other expenses related to or arising from the replacement of defective parts.
- Products used for pile-driving, wire rope activated clamshell or dragline applications. If purchaser uses the Products for pile-driving, wire rope activated clamshell or dragline application, the limited warranty will be deemed to have been violated for abuse.
- Any costs associated with providing *LSI* with data logging equipment.

6.5 Limitation of Liability

To the maximum extent permitted by applicable law, in no event will *LSI* be liable to the purchaser or any third party for any indirect, special, consequential, incidental or exemplary damages whatsoever, including but not limited to loss or revenue or profit, lost or damaged data, business interruption or any other pecuniary loss whether based in contract, tort or

other causes of action, even if *LSI* has been advised of the possibility of such damages. In any event, the total liability of *LSI* arising from any cause of action or claim whatsoever, whether (1) in contract, (2) in tort (including negligence, whether sole, joint, contributory, concurrent or otherwise, but not including intentional, reckless or wanton tort), (3) under strict liability, (4) under any environmental or antipollution law or regulation, (5) connected with any toxic or hazardous substance or constituent, (6) arising out of any representation or instruction, or under any warranty, (7) or otherwise, arising out of, connected with, or resulting from the design, manufacture, sale, resale, delivery, repair, replacement or use of Products or the furnishing of any service shall in no event exceed the price allocable to and paid to *LSI* for the individual unit of Products or service or part thereof which gives rise to the cause of action or claim.

SOME STATES OR JURISDICTIONS DO NOT ALLOW THE LIMITATION OR EXCLUSION OF LIABILITY FOR INCIDENTAL OR CONSEQUENTIAL DAMAGES, SO THE ABOVE LIMITATION OR EXCLUSION MAY NOT APPLY TO YOU.

6.6 Recommended Practices

LSI recommends careful consideration of the following factors when specifying and installing the Products. Before installing a Product, the Installation, Operation, and Maintenance instructions provided with the unit must be read and understood and complied with.

6.7 Choice of law

This Limited Warranty shall be governed by and construed in accordance with the laws of : 1. For Products sold in Canada: the Province of Quebec or, For Products sold in the USA: the State of Florida, without giving effect to principles of conflicts of law. You agree that the exclusive venue for any disputes arising under this Agreement shall be the state and federal courts located in Orlando, Florida.

6.7a Entire Agreement

This document contains the entire agreement of the parties regarding the subject matter of the Product and supersedes all previous communications, representations, understandings and agreements, either oral or written, between you and *LSI*.

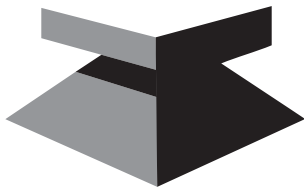

LSI

Load Systems International

LSI Contact Information

Technical Support:

LSI Technical Support is available 24 hours a day, 7 days a week from our Houston and Dubai locations.

Please direct all technical support questions to either of these locations or contact us via email:

techsupport@loadsystems.com

North America

Toll Free Phone: (888) 819 4355

Toll Free Fax: (888) 238 4099

International: +1 (281) 664 1330

Middle East & Africa

Phone: +971 6 557 3814

Fax: +971 6 557 3815

USA Corporate Office:

**9223 Solon, Suite A
Houston, TX 77064**

Direct Phone: 281.664.1330

Direct Fax: 281.664.1390

Email: sales@loadsystems.com

Canadian Corporate Office:

**4495 Blvd. Hamel, Suite 110
Quebec QC G1P 2J7**

Direct Phone: (418) 650 2330

Direct Fax: (418) 650 3340

Email: sales@loadsystems.com

Dubai Corporate Office:

**Y02 Saif Zone P.O. Box 7976
Sharjah - UAE**

Phone: +971 6 557 3814

Fax: +971 6 557 3815

Email: lsifzc@emirates.net.ae

© 2009, Load Systems International Inc.