

## Operation and Installation Guide



## Contents

### Contents

<b>1.0</b>	<b>Introduction .....</b>	<b>7</b>
1.1	Organization .....	7
1.2	Other Literature Referenced .....	8
1.3	Documentation Conventions .....	8
1.3.1	Type Styles Used in this Guide .....	8
1.3.2	Tips, Important Notes, Cautions, and Warnings .....	8
1.4	FCC Notice .....	9
1.4.1	Part 15 .....	9
1.4.2	Part 68 .....	9
<b>2.0</b>	<b>Overview .....</b>	<b>10</b>
2.1	Specifications .....	10
2.2	SIA Control Panel Standard .....	12
2.3	Standard Features .....	12
2.3.1	Points .....	12
2.3.2	Areas and Accounts .....	12
2.3.3	Communicator .....	12
2.3.4	Command Centers .....	13
2.3.5	Keyswitch .....	13
2.3.6	Alarm Event Memory .....	13
2.3.7	Event Log .....	13
2.3.8	EMI/Lightning Transient Protection .....	13
2.3.9	Programming .....	13
2.3.10	Other Features .....	13
2.3.11	Control Panel Assembly .....	14
2.3.12	Listings and Approvals .....	14
<b>3.0</b>	<b>Installation .....</b>	<b>15</b>
3.1	Before You Begin .....	15
3.2	Enclosure Options .....	15
3.3	Premises Wiring .....	15
3.4	Installing the Assembly .....	16
3.4.1	Connecting Earth Ground .....	16
3.4.2	Closing the Installer Switch .....	16
3.5	Finishing the Installation .....	17
3.5.1	Earth Ground and Installer Switch .....	17
3.5.2	Charge the Battery as You Finish .....	17
3.5.3	Install and Wire Detection Devices .....	17
3.5.4	Install Modules .....	17
3.5.5	Make the Telephone Connections .....	17
3.5.6	Connect the On-Board Points and Command Centers .....	17
3.5.7	Power Up .....	18
3.6	Programming the Panel .....	18
3.7	Check for Fire Alarm Verification .....	18
3.8	Testing the System .....	18
<b>4.0</b>	<b>Power Supply .....</b>	<b>19</b>
4.1	Primary Power .....	19
4.1.1	Primary (AC) Power Circuit .....	19
4.1.2	Installing the Transformer .....	19
4.2	Secondary Power .....	19
4.2.2	Installing the Battery .....	19
4.2.3	Replacement .....	19

4.2.4	Battery Supervision .....	19
4.2.5	Battery Charging Circuit - Float Charge .....	20
4.2.6	Battery Discharge/Recharge Schedule .....	20
4.2.7	System Status LED .....	20
4.3	External Power Supply .....	20
<b>5.0</b>	<b>Power Outputs .....</b>	<b>21</b>
5.1	Circuit Protection .....	21
5.2	Available Power .....	21
5.2.1	Auxiliary Power .....	21
5.2.2	Installer's Keypad Connector .....	21
5.2.3	Alarm Power .....	21
5.3	Continuous Power Output .....	21
5.3.1	Continuous Current Draw .....	21
5.4	Alarm Power .....	21
5.4.1	Available Power .....	21
5.5	Output Programming .....	22
<b>6.0</b>	<b>Telephone Connections .....</b>	<b>23</b>
6.1	Registration .....	23
6.2	Notification .....	23
6.3	Location .....	23
6.4	Phone Cord Connection .....	23
6.5	System Status LED (Red) .....	23
6.6	Dialing Format .....	23
6.7	Phone Line Fault .....	24
6.8	Called Party Disconnect .....	24
6.9	Communication Failure .....	24
6.10	Ground Start .....	24
6.10.1	Program PO1 for Ground Start .....	24
<b>7.0</b>	<b>On-Board Sensor Loops .....</b>	<b>27</b>
7.1	Description .....	27
7.2	Two-wire Smoke Detector Configuration .....	27
7.3	Four-wire Smoke Detector Configuration .....	27
7.4	Sensor Loop 1 Configuration .....	28
7.5	Single Point Configuration (Points 2 to 8) .....	28
7.6	Doubled Point Configuration .....	29
7.7	Sensor Loop Response Time .....	29
<b>8.0</b>	<b>Off-Board Sensor Loops .....</b>	<b>31</b>
8.1	SDI Point Expanders .....	31
8.2	DX2010 Point Expander Module .....	33
8.2.1	DX2010 Overview .....	33
8.2.2	DX2010 Installation .....	33
8.2.3	DX2010 to Panel SDI Bus Connections .....	34
8.2.4	DX2010 Auxiliary Output Connections .....	36
8.2.5	DX2010 Tamper Input Connections .....	36
8.2.6	DX2010 Sensor Loop (Point) Connections .....	36
8.2.7	DX2010 Address Programming .....	37
8.2.8	DX2010 Status LED .....	38
<b>9.0</b>	<b>On-Board Outputs .....</b>	<b>39</b>
<b>10.0</b>	<b>Off-Board Outputs .....</b>	<b>41</b>
10.1	Overview .....	41
10.2	DX3010 Octo-Output Module .....	41
10.2.1	Overview .....	41

## Contents

10.2.2	Configuring the DX3010 Octo-Output Module .....	41
10.2.3	Relay Outputs .....	41
10.2.4	Installation .....	42
10.2.5	DX3010 to D6412/D4412 SDI Bus Wiring Connections .....	42
10.2.6	Address Programming .....	44
<b>11.0</b>	<b>Arming Devices .....</b>	<b>45</b>
11.1	Description .....	45
11.2	Command Centers .....	45
11.2.1	Assigning the Command Center an Address .....	45
11.2.2	Command Center Installation .....	46
11.3	D268/D269, D279 Independent Zone Control .....	47
11.4	Keyswitch .....	47
11.4.1	Keyswitch Description .....	47
11.4.2	Keyswitch Programming .....	47
11.4.3	Keyswitch Installation .....	48
11.4.4	Keyswitch Operation .....	48
<b>12.0</b>	<b>SDI Devices .....</b>	<b>49</b>
12.1	Description .....	49
12.2	Installation .....	49
12.3	DX4010 RS-232 Serial Interface Module .....	50
12.3.1	DX4010 Installation .....	50
12.3.2	DX4010 to D6412/D4412 SDI Bus Wiring Connections .....	51
12.3.3	RAM IV Direct Connection .....	51
12.3.4	Configuration Jumpers .....	52
12.3.5	Supervision .....	52
12.3.6	DX4010 Module's DB9 Connector .....	52
<b>13.0</b>	<b>Installer's Keypad and Installer Mode .....</b>	<b>53</b>
13.1	Installer's Keypad Connector .....	53
13.2	Entering the Installer Mode .....	53
13.2.1	Installer's Passcode .....	53
13.2.2	Service Start/Service End Reports .....	54
13.3	Installer's Menu .....	54
13.3.1	Press [1] for Bell Test .....	54
13.3.2	Press [2] for Strobe Test .....	54
13.3.3	Press [3] for Battery Test .....	54
13.3.4	Press [4] for Test Report .....	54
13.3.5	Press [5] for Point Status .....	54
13.3.6	Press [6] for Output Test .....	55
13.3.7	Press [7] for RF Menu .....	55
13.3.8	Press [8] for Keypad Program .....	56
13.3.9	Press [9] Program Key .....	57
13.3.10	Exiting the Installer's Menu .....	58
13.3.11	Press [0] Call for Service Details .....	58
<b>14.0</b>	<b>Installation Label .....</b>	<b>59</b>
<b>15.0</b>	<b>Terminal Quick Reference .....</b>	<b>61</b>
<b>16.0</b>	<b>Troubleshooting .....</b>	<b>63</b>
16.1	Introduction .....	63
16.1.1	Arming Issues .....	63
16.1.2	Point Issues .....	63
16.1.3	Command Center Issues .....	64
16.1.4	Programming Issues .....	64
16.1.5	Miscellaneous Issues .....	64

<b>Appendix A: Approved Applications Compliance Guide .....</b>	<b>65</b>
A-1 Listings and Approvals .....	65
A-2 System Chart .....	66
A-3 System Wiring Diagrams, Issue A .....	67
A-4 Current Rating Chart for Standby Battery Calculations .....	68
A-5 Standby Battery Requirements .....	68
A-6 Standby Battery Calculation for NFPA 72 Fire Alarm Applications .....	68
<b>Appendix B: SDI Address Chart .....</b>	<b>69</b>

## Tables

Table 1: D6412/D4412 Installation Guide Organization .....	7
Table 2: Other Literature Referenced .....	8
Table 3: Compatible Command Centers .....	13
Table 4: System Status LED Description .....	20
Table 5: On-Board Sensor Loops .....	28
Table 6: Point Scan Time/Pulse Count Time Selections .....	29
Table 7: Point Expansion Mapping .....	31
Table 8: DX2010 Wire Lengths .....	34
Table 9: DX2010 Address 106 .....	37
Table 10: DX2010 Address 107 (for D6412 only) .....	37
Table 11: DX2010 Address Settings .....	38
Table 12: DX2010 Address Jumper Settings .....	38
Table 13: DX3010 Wire Lengths .....	42
Table 14: DX3010 Address Settings .....	44
Table 15: DX3010 Address Jumper Settings .....	44
Table 16: Command Center Address Assignments DIP Switch Settings .....	45
Table 17: Command Center Wire Lengths .....	46
Table 18: DX4010 Address Settings .....	52

## Figures

### Figures

Figure 1: System Configuration .....	10
Figure 2: Enclosure Mounting .....	16
Figure 3: Installer Switch .....	16
Figure 4: System Status LED .....	20
Figure 5: On-Board Outputs .....	22
Figure 6: RJ31X/RJ38X Wiring .....	23
Figure 7: Ground Start .....	25
Figure 8: Typical Two-Wire Smoke Detector Wiring .....	27
Figure 9: Typical Four-Wire Smoke Detector Wiring .....	27
Figure 10: Sensor Loop 1 Wiring .....	28
Figure 11: Single Point Sensor Loop Wiring .....	28
Figure 12: On-Board Doubled Point Sensor Loop Wiring .....	29
Figure 13: Installing the DX2010 in D203 Enclosure .....	33
Figure 14: Installing the DX2010 in the Panel Enclosure .....	33
Figure 15: Optional Enclosure Mounting Locations for the DX2010 .....	34
Figure 16: Wiring the DX2010 to the D6412/D4412 .....	35
Figure 17: Wiring the DX2010 for External Power Supply .....	35
Figure 18: Auxiliary Output Connections .....	36
Figure 19: DX2010 Tamper Input Wiring .....	36
Figure 20: DX2010 Sensor Loop Wiring, Single Loop Configuration .....	37
Figure 21: DX2010 Sensor Loop Wiring, Doubled Loop Configuration .....	37
Figure 22: DX2010 DIP Switch Configuration .....	38
Figure 23: DX2010 Status LED .....	38
Figure 24: PO1 Wiring .....	39
Figure 25: PO2-PO4 Wiring .....	39
Figure 26: DX3010 - Control Panel Enclosure Side Mounting .....	42
Figure 27: Installing the DX3010 in a Remote Enclosure .....	42
Figure 28: Wiring the DX3010 to the D6412/D4412 .....	43
Figure 29: Wiring for External Power Supply .....	43
Figure 30: DX3010 Address DIP Switches .....	44
Figure 31: Command Center DIP Switch Orientation .....	45
Figure 32: Wiring Command Centers to the D6412/D4412 .....	46
Figure 33: External Power for Command Centers .....	47
Figure 34: Keystitches .....	48
Figure 35: SDI Device Wiring .....	49
Figure 36: External Power for SDI Devices .....	50
Figure 37: DX4010 RS-232 Serial Interface Module .....	50
Figure 38: DX4010 Power Connections .....	51
Figure 39: Creating a RAM IV Direct Connection .....	51
Figure 40: DX4010 P2/P3 Jumper Pin Settings .....	52
Figure 41: DX4010 DIP Switch Orientation .....	52
Figure 42: DX4010 D89 Connector Layout .....	52
Figure 43: Installer's Keypad .....	53
Figure 44: Installer Switch .....	54
Figure 45: Adding RF ID Codes Menu Display .....	55
Figure 46: RF ID Code Display .....	55
Figure 47: Test RF Devices Display .....	55
Figure 48: RF Device Test Status Display .....	55
Figure 49: RF ID Code Display .....	56
Figure 50: PK32 to D6412/D4412 Connections .....	57

## 1.0 Introduction

This guide addresses the installation of the D6412 and D4412 Control Panel **only**, and should not be used for any other panel.

### 1.1 Organization

This guide is divided into 16 sections with seven appendices. *Table 1* contains a summary of each section.

Section	Description
1.0	<b>Introduction</b> - This section.
2.0	<b>Overview</b> - Overview of the D6412/D4412 Control Panel, including operational specifications, standard and new features.
3.0	<b>Installation</b> - Basic installation instructions, including everything needed to power up the panel and ready for programming.
4.0	<b>Power Supply</b> - Information about the primary and secondary power sources and instructions for correcting problems with them.
5.0	<b>Power Outputs</b> - Information about the available powered outputs, including the alarm output and built-in siren driver.
6.0	<b>Telephone Connections</b> - Information about connecting the phone line.
7.0	<b>On-Board Sensor Loops</b> - Information about the eight on-board sensor loops available on the D6412/D4412.
8.0	<b>Off-Board Sensor Loops</b> - Information about available off-board sensor loops, including detailed instructions for connecting the DX2010 Point Expansion Module.
9.0	<b>On-Board Outputs</b> - Information about the four on-board programmable outputs.
10.0	<b>Off-Board Outputs</b> - Information about available off-board programmable outputs, including detailed instructions for connecting the DX3010 OctoOutput Module.
11.0	<b>Arming Devices</b> - Information about command centers, keyswitches, and independent zone controls.
12.0	<b>SDI Devices</b> - Descriptions and installation instructions for various optional modules that connect to the D6412/D4412's data terminals (SDI bus).
13.0	<b>Installer's Keypad and Installer Mode</b> - Information for using an Installer's Keypad and the Installer's Mode.
14.0	<b>Installation Label</b> - Copy of the installation label found inside the D6412/D4412 terminal.
15.0	<b>Terminal Quick Reference</b> - Chart providing a short description of each D6412/D4412 terminal.
16.0	<b>Troubleshooting</b> - Potential solutions to a variety of commonly encountered problems.
Appendices	A: Approved Applications and Compliance Guide B: SDI Address Chart

Table 1: D6412/D4412 Installation Guide Organization

## Introduction

### 1.2 Other Literature Referenced

Throughout this guide, references are made to other documentation. Review the documents in the table below for a complete description of the panel. Part numbers are included for ordering purposes.

Document Name	Part Number
<i>D6412/D4412 Program Entry Guide</i>	45351
<i>D6412 Program Record Sheet</i>	45350
<i>D4412 Program Record Sheet</i>	50485
<i>D6412/D4412 TSN: Smoke Detector Compatibility</i>	46928
<i>User's Guide for LED Command Centers</i>	46840
<i>User's Guide for Text Command Centers</i>	46841
<i>D6412 Firmware Release Notes</i>	46929
<i>D4412 Firmware Release Notes</i>	50482
<i>DX2010 Installation Guide</i>	49533
<i>DX3010 Installation Guide</i>	49529
<i>DX4010 Installation Guide</i>	49539

Table 2: Other Literature Referenced

### 1.3 Documentation Conventions

These conventions are intended to call out important features, items, notes, cautions, and warnings that the reader should be aware of in reading this document.

#### 1.3.1 Type Styles Used in this Guide

To help identify important items in the text, the following type styles are used:

<b>Bold text</b>	Usually indicates selections that you may use while programming your panel. It may also indicate an important fact that should be noted.
<b><i>Bold italicized</i></b>	Used to denote notes, cautions, and/or warnings.
<i>Italicized text</i>	Refers the user to another part of the guide or to another document entirely.
Courier text	Indicates what may appear on the command center/keypad or in a report received at the central station receiver.
[Text in brackets]	Indicates to the user that a specific key should be pressed. Example: Press [Cmd] to exit this feature.

#### 1.3.2 Tips, Important Notes, Cautions, and Warnings

Throughout this document, helpful tips, important notes, cautions and warnings are presented for the reader to keep in mind. These appear different from the rest of the text as follows;



***Important Notes - should be heeded for successful operation and programming. Also, tips and shortcuts may be included here.***



***Caution - These caution the operator that physical damage to the panel and/or optional equipment may occur.***



***Warning - These warn of the possibility of physical damage to the operator and/or equipment.***



**1.4 FCC Notice****1.4.1 Part 15**

This equipment has been tested and found to comply with the limits for a Class B digital device, pursuant to Part 15 of the FCC rules. These limits are designed to provide reasonable protection against harmful interference when the equipment is operated in a commercial environment.

This equipment generates, uses, and can radiate radio frequency energy and, if not installed and used in accordance with this instruction guide, may cause harmful interference to radio communications.

Operation of this equipment in a residential area is likely to cause harmful interference, in which case the user is required to correct the interference at his own expense.

**1.4.2 Part 68**

This equipment complies with Part 68 of FCC rules. A label contains, among other information, the FCC registration number and ringer equivalence number (REN). If requested, this information must be provided to the telephone company.

The Bosch Security Systems D6412/D4412 Control Panel is registered for connection to the public telephone network using an RJ38X or RJ31X jack.

The ringer equivalence number (REN) is used to determine the number of devices that may be connected to the telephone line. Excessive RENs on the telephone line may result in the devices not ringing in response to an incoming call. In most, but not all areas, the sum of the RENs should not exceed five (5). To ascertain of the number of devices that may be connected to the line, as determined by the RENs, contact the telephone company to determine the maximum REN for the calling area.

If the D6412/D4412 Control Panel causes harm to the telephone network, the telephone company notifies you in advance. If advance notice isn't practical, the telephone company notifies the customer as soon as possible. Also, you are advised of your right to file a complaint with the FCC if you believe it is necessary.

The telephone company may make changes in its facilities, equipment, operations, or procedures that could affect the operation of the equipment. If this happens, the telephone company provides advance notice so you can make the necessary modifications for maintaining uninterrupted service.

If trouble is experienced with the D6412/D4412 Control Panel, please contact Bosch Security Systems Customer Service for repair and/or warranty information. If the trouble is causing harm to the telephone network, the telephone company may request that you remove the equipment from the network until the problem is resolved. User repairs must not be made, and doing so voids the user's warranty.

This equipment cannot be used on public coin service provided by the telephone company. Connection to Party Line service is subject to state tariffs. (Contact your state public utilities commission for information.)

<b>FCC Registration Number:</b>	ESVMUL-46531-AL-E
<b>Ringer Equivalence:</b>	0.1B
<b>Service Center in USA:</b>	National Repair Center 130 Perinton Parkway Fairport, NY 14450-9199 USA (800) 289-0096 ext. 4220

## Overview

### 2.0 Overview

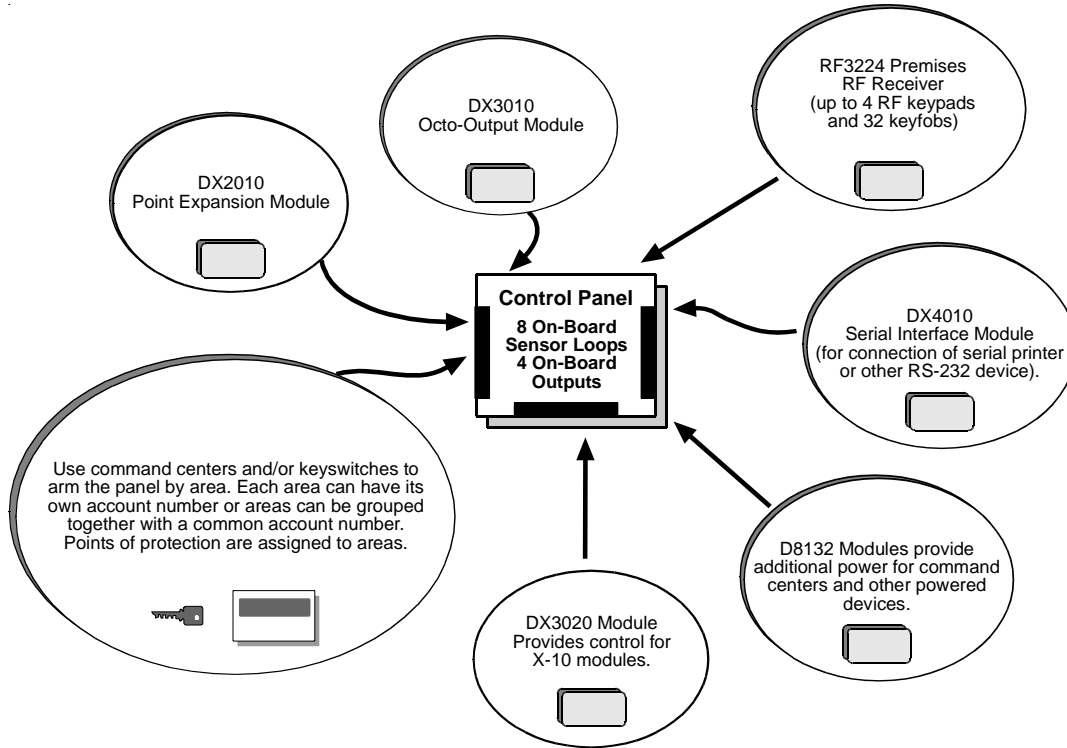

Figure 1: System Configuration

### 2.1 Specifications

<b>Voltage Input</b>	
Primary:	18 VAC 22 VA class 2 plug-in transformer CX4010 (D1825)
Secondary:	12 VDC, 7 Ah sealed lead acid rechargeable battery or 12 VDC, 18 Ah sealed lead acid rechargeable battery.
<b>Current Requirements</b>	
Panel:	100 mA See <i>Appendix : Approved Applications Compliance Guide</i> for the current requirements of other system components.
<b>Power Outputs</b>	
Continuous:	Up to 600 mA maximum at 11.5 VDC to 12.4 VDC (continuous supply) total for all devices and outputs for non UL applications.
Note:	<b>Up to 400 mA at 11.5 VDC to 12.4 VDC for UL Listed burglary applications, 120 mA for Fire and Combined Burglary/Fire (continuous supply) total for all devices and outputs.</b>
Alarm Power:	400 mA for Fire and combined Fire/Burglary; 1500 mA for UL Burglary; 1850 mA for other (not investigated by UL). Applies to all four outputs combined. See the <i>Outputs</i> section of the <i>D6412/D4412 Program Entry Guide</i> (P/N: 45351).
<b>Battery Discharge/Recharge Schedule</b>	
Discharge Cycle:	<ul style="list-style-type: none"> <li>AC Off: Command centers indicate trouble. AC Fail Report sent as programmed.</li> <li>13.8 VDC: Charging Float Level.</li> <li>12.1 VDC: Low Battery trouble at command centers. Low Battery Report as programmed.</li> <li>10.2 VDC: Panel shuts down as voltage falls below 10.2 VDC.</li> </ul>
Recharge Cycle:	<ul style="list-style-type: none"> <li>AC On: Panel restarts, battery charging begins, AC Restoral Report sent as programmed, AC trouble clears from command centers.</li> <li>13.0 VDC: Battery Restoral Reports sent, battery trouble clears from command centers.</li> <li>3.8 VDC: Battery float charged.</li> </ul>

<b>Minimum Operating Voltage</b>	10.2 VDC
<b>SDI Bus (Data)</b>	12 VDC nominal. 305 m (1000 ft.) of 22 AWG (0.8 mm) cable.
<b>Telephone Connections</b>	RJ31X or RJ38X jack can be interfaced with panel
<b>Environmental</b>	Temperature: 0°C to +50°C (+32° to +122°F) Relative Humidity: 5% to 85% at +30°C (+86°F) non-condensing
<b>Arming Stations</b>	<ul style="list-style-type: none"> <li>• D625 VF Text Command Center</li> <li>• D623 LCD Text Command Center</li> <li>• D621 LED Command Center</li> <li>• Keyswitch</li> </ul>
<b>Compatible Enclosures</b>	D2203 Universal Enclosure (included with panel), D8103 Universal Enclosure, D8109 Fire Enclosure, D8108A Attack Resistant Enclosure. <i>Note: When ordering a compatible enclosure, order the D6412M (includes the mounting skirt and the D6412LC) or the D4412M (includes the mounting skirt and the D4412LC). In addition, order the CX4010 transformer.</i>
<b>Compatible Accessories</b>	<ul style="list-style-type: none"> <li>• D621 LED Command Center</li> <li>• D623 Text Command Center, LCD Display</li> <li>• D625 Text Command Center, Vacuum Fluorescent Display</li> <li>• DX2010 (D9528) Point Expansion Module</li> <li>• DX3010 (D9529) Octo-Output Module</li> <li>• DX3020 (X7410I) Module (not investigated by UL)</li> <li>• DX4010 (D9533) Serial Output Module (not investigated by UL)</li> <li>• DX8010 Telephone Command Module (not investigated by UL)</li> <li>• DS RF3224 Premises RF Receiver</li> <li>• DS RF3332/3334 Keyfob (not investigated by UL)</li> <li>• DS RF3341 Keypad (not investigated by UL)</li> <li>• Programming Key (PK32)</li> </ul>
<b>Control Panel Configurations</b>	<ul style="list-style-type: none"> <li>• D6412 - Complete control panel assembly in the D2203 Universal Enclosure. A CX4010 Transformer is supplied.</li> <li>• D6412LT - Complete control panel assembly in the D2203 Universal Enclosure. A CX4010 Transformer must be ordered separately.</li> <li>• D6412LC - Complete control panel assembly without an enclosure or transformer. A CX4010 Transformer must be ordered separately.</li> <li>• D6412M - Complete control panel assembly with a mounting skirt for the compatible enclosure. A CX4010 Transformer must be ordered separately. See <i>Compatible Enclosures</i> in this table for compatible enclosure alternatives.</li> <li>• D4412 - Complete control panel assembly in the D2203 Universal Enclosure. A CX4010 Transformer is supplied.</li> <li>• D4412LT - Complete control panel assembly in the D2203 Universal Enclosure. A CX4010 Transformer must be ordered separately.</li> <li>• D4412LC - Complete control panel assembly without an enclosure or transformer. A CX4010 Transformer must be ordered separately.</li> <li>• D4412M - Complete control panel assembly with a mounting skirt for the compatible enclosure. A CX4010 Transformer must be ordered separately. See <i>Compatible Enclosures</i> in this table for compatible enclosure alternatives.</li> </ul>

## Overview

### 2.2 SIA Control Panel Standard

The D6412/D4412 utilizes features within the SIA Control Panel Standard, Features for False Alarm Reduction, SIA CP-01-1994.02 (R2000.01). SIA features are noted in the *D6412/D4412 Program Entry Guide* (P/N: 45351). The standard is available through:

Security Industry Association (SIA)  
635 Slaters Lane, Suite 110  
Alexandria, Virginia 22314

You can e-mail requests for standards to: Standards@SIAOnline.org.

### 2.3 Standard Features

#### 2.3.1 Points

The Bosch Security Systems D6412 Control Panel provides up to 40 separate points of protection (24 for the D4412 panel). Point programming parameters determine the panel's response to open and shorted conditions on the point's sensor loop. Points are programmed individually with several options to customize the protection to your installation. There are eight sensor loops available on the panel (for on-board points). Off-board point locations can be standard wired sensor loops (DX2010 Point Expander) or premises RF transmitters (premises RF receiver is required). The 40 points of protection for the D6412 (24 points for the D4412) can be located on any combination of wired and RF locations.

#### 2.3.2 Areas and Accounts

The system supports up to four separate areas for the D6412 and up to two separate areas for the D4412. You can assign all points to a single area or spread them out over a maximum of two or four areas, model dependent.

You arm and disarm the panel by are. You can arm and disarm several areas with one function. You can also assign a passcode an authority level that allows a user to arm an area from a remote command center in another area. Assigning each area its own account number creates four (D6412) or two (D4412) separate accounts in one panel. Assigning the same account number to different areas groups them together in a single account.

Area options include: exit tone and delay, separate fire and burglary outputs, and auto opening and closing skeds. Area 1 can be programmed as a common area. A "First to Open, Last to Close" arming feature is available.

#### 2.3.3 Communicator

The panel uses a built-in digital communicator to send reports to the receiver. It transmits reports in either Modem IIIa<sup>2</sup>, Contact ID, or Pager format.

Only the following central station receivers support the panel's Modem IIIa<sup>2</sup> format:

- D6600 with CPU v01.01.03 (or higher)
- D6500 with D6511 MPU v1.05 (or higher)



IMPORTANT

*The D6500 with D6510 MPU does not support the panel's Modem IIIa<sup>2</sup> Format.*

The panel connects to an RJ31X jack for phone line seizure. Connection to the RJ31X complies with FCC regulations for using the public telephone network. You can program the panel to route reports to one of two routing destinations.

The system has routing capabilities that allow you to direct groups of system event reports and individual point reports to two different routing destinations. The reports can be routed to either destination, both destinations, or to Destination 2 only on failure of Destination 1.

Each routing destination can be programmed with two phone numbers.



IMPORTANT

*Check panel communications at least once annually (from panel to central station) to verify the panel is communicating properly in the selected reporting format.*

### 2.3.4 Command Centers

You can connect a maximum of eight, fully-supervised command centers to the system. The available power affects the total number of command centers you can connect without providing an auxiliary power supply.

The panel transmits a Serial Device Trouble Report, **SDI MISSING** in the Modem IIIa<sup>2</sup> format or **Sys Peripheral Trouble** in the Contact ID format, if it loses communication with a command center. *Table 3* shows the command centers compatible with the panel. Refer to *Command Center* in the *D6412/D4412 Program Entry Guide* (P/N: 45351) for complete details on programming command center options.

Model	Display
D621	16-Point LED
D623	Two lines of 16 characters, LCD
D625	Two lines of 16 characters, vacuum fluorescent

Table 3: Compatible Command Centers

### 2.3.5 Keyswitch

You can arm and disarm any of the available areas with maintained or momentary closure devices such as keyswitches. Point programming determines loop responses and which area a keyswitch controls. Sub-control units (D279) can arm and disarm individual points.

### 2.3.6 Alarm Event Memory

The system uses alarm event memory to store alarm events for each area. You can view the area alarm events at a command center assigned to the area. The panel clears the area's alarm event memory and starts storing new alarm events when you turn the area on.

### 2.3.7 Event Log

The system stores 254 events from all areas in its event log. All events can be stored even if the panel does not send a report for them. You can view the log at a text command center (the D623 for example), print it locally using the DX4010 Serial Interface Module and a serial printer, or upload it to the Remote Account Manager (RAM IV).

See *Appendix B* in the *D6412/D4412 Program Entry Guide* (P/N: 45351) for a listing of log events and how to view them.

### 2.3.8 EMI/Lightning Transient Protection

The panel maintains Bosch Security Systems high level of quality and field dependability. Its design significantly reduces electromagnetic interference and malfunction generally caused by lightning.

### 2.3.9 Programming

Use either a text keypad or the Remote Account Manager (RAM IV) to program the panel. Refer to the *D6412/D4412 Program Entry Guide* (P/N: 45351) for programming options.

### 2.3.10 Other Features

The panel has many programmable features. A short list of some of the features follows.

- Supervision of AC (primary power), battery (secondary power), SDI bus devices (keypads, point expanders, programmable output modules, alternate communication modules, etc.), central processing unit (CPU), and the telephone line (voltage only).
- Automatic system test reports
- Remote access for programming, diagnostics, and log uploads using the Remote Account Manager (RAM IV)
- Fire Alarm Verification
- Up to twenty (D6412) or twelve (D4412) Programmable Outputs, including a supervised siren driver
- Skeds (scheduled events)

Complete details on all the features can be found in the *D6412/D4412 Program Entry Guide* (P/N: 45351).

# D6412/D4412

## Overview

### 2.3.11 Control Panel Assembly

The Bosch Security Systems control panel is shipped from the factory pre-assembled. You should receive the following parts with your panel.

#### Literature Package

<b>D6412 Control Panel</b>	<i>D6412/D4412 Installation Guide</i> (P/N: 45349)* <i>D6412 Program Record Sheet</i> (P/N: 45350)* <i>D6412/D4412 Program Entry Guide</i> (P/N: 45351)* <i>D6412 Release Notes</i> (P/N: 46929) <i>D6412/D4412 TSN: Smoke Detector Compatibility</i> (P/N: 46928)* <i>D6412 Specifications Sheet</i> (P/N: 48392)*
<b>D4412 Control Panel</b>	<i>D6412/D4412 Installation Guide</i> (P/N: 45349)* <i>D4412 Program Record Sheet</i> (P/N: 50485)* <i>D6412/D4412 Program Entry Guide</i> (P/N: 45351)* <i>D4412 Release Notes</i> (P/N: 50482) <i>D6412/D4412 TSN: Smoke Detector Compatibility</i> (P/N: 46928)*

\* *This literature is available in a separate literature package for dealers.*

#### Assembly

- Printed Circuit Board (PCB)
- CX4010 transformer (order separately when ordering the D6412LC, D4412LC, D6412LT, D4412LT, D6412M, or D4412M)
- Two mounting clips
- Two #6 x 3/4 in. screws
- Eight 2.2 k $\Omega$  EOL resistors (eight-pack [P/N: 47819], single resistor [P/N: 25944B])
- Eight 3.65 k $\Omega$  point-doubling EOL resistors (eight-pack [P/N: 47821], single resistor [P/N: 38130B])
- One 2.21 k $\Omega$  fire EOL resistor (P/N: 25899)
- Two 14 in., 18 AWG (1.2 mm), color-coded battery leads
- Three PCB support standoffs (P/N: 30503B)

#### Ordered Separately

Order the following to complete a basic eight-point installation.

- Command center (or keyswitch)
- D118 Speaker (for PO2 in supervised configuration) **D118 not investigated by UL.**
- D126 Battery
- D164 Phone Cord

Configured packages are also available. Please consult your Bosch Security Systems Product Catalog.

### 2.3.12 Listings and Approvals

<b>Fire</b>	Underwriters Laboratories Household Fire Warning UL985
<b>CSFM</b>	Approved by the California State Fire Marshal for Control Units (Household)
<b>Burglary</b>	Underwriters Laboratories <ul style="list-style-type: none"><li>- UL1023 Household</li><li>- UL365 Police Connect</li><li>- UL609 Local</li><li>- UL1076 Proprietary</li><li>- UL609 Central Station</li><li>- UL609 Digital Alarm</li></ul>

## 3.0 Installation

### 3.1 Before You Begin

This section contains a general installation procedure. It refers to other sections of the guide for detailed instructions.

Bosch Security Systems recommends you review this guide and the *D6412/D4412 Program Entry Guide* (P/N: 45351) before you begin installation to determine the hardware and wiring requirements for the features you want to use.

As you read through this guide, have the following documents at hand:

- *D6412 Program Record Sheet* (P/N: 45350) or *D4412 Program Record Sheet* (P/N: 50485)
- *User's Guide (Text Command Center* [P/N: 46841]; *LED Command Center* - 46840). A condensed version of the *User's Guide* is found in the *D6412/D4412 Program Entry Guide* (P/N: 45351).
- Installation guide for each command center model you intend to install.

Before you begin installing the panel, you should be familiar with keypad programming or the Remote Account Manager (RAM IV).

### 3.2 Enclosure Options

The D2203 Enclosure is supplied with the standard D6412/D4412 Control Panel. To mount the D6412 in one of the Bosch Security Systems enclosures listed below, order the D6412M version (order the D4412M version for the D4412).

- D8103 Universal Enclosure (gray)
- D8109 Fire Enclosure (red)
- D8108A Attack Resistant Enclosure (gray)

The "M" version substitutes a D2202 Mounting Skirt for the D2203 enclosure allowing installation in the other enclosures. "M" does not include a transformer. Order a CX4010 separately. Refer to *Appendix A: Approved Applications Compliance Guide* to determine if your application requires a specific enclosure.

Mount the enclosure in the desired location.

### 3.3 Premises Wiring

Run the necessary wiring throughout the premises and route the wires into the enclosure.



*Electro Magnetic Interference (EMI) may cause problems. EMI may occur if you install the system or run system wires near the following:*

- *Computer network system*
- *Electrical lines, fluorescent fixtures or telephone cabling*
- *Ham radio transmitter site*
- *Heavy machinery and motors*
- *High voltage electrical equipment or transformers*
- *PBX telephone system*
- *Public service (police, fire departments, etc.) using radio communications*
- *Radio station transmitter site or other broadcast station equipment*
- *Welding shop*

If you think that EMI may be a problem, use shielded cable. The drain wire for the shielded cable must have continuity from the earth ground terminal on the panel to the end of the wire run. If continuity is not maintained, the shielded cable may aggravate potential noise problems rather than eliminate them.

Connecting the drain wire to ground at any place other than the earth ground terminal may also produce problems. If you cut the drain wire to install devices, be certain to splice it together. Carefully solder and tape all splices.

## Installation

### 3.4 Installing the Assembly

1. Place the panel mounting clips on the appropriate standoff in the enclosure (see *Figure 2*).
2. Slide the panel into the slots at the top of the enclosure and then secure it with the two screws provided (see *Figure 2*).
3. Connect earth ground to the panel before making any other connections (see *Section 3.4.1 Connecting Earth Ground*).

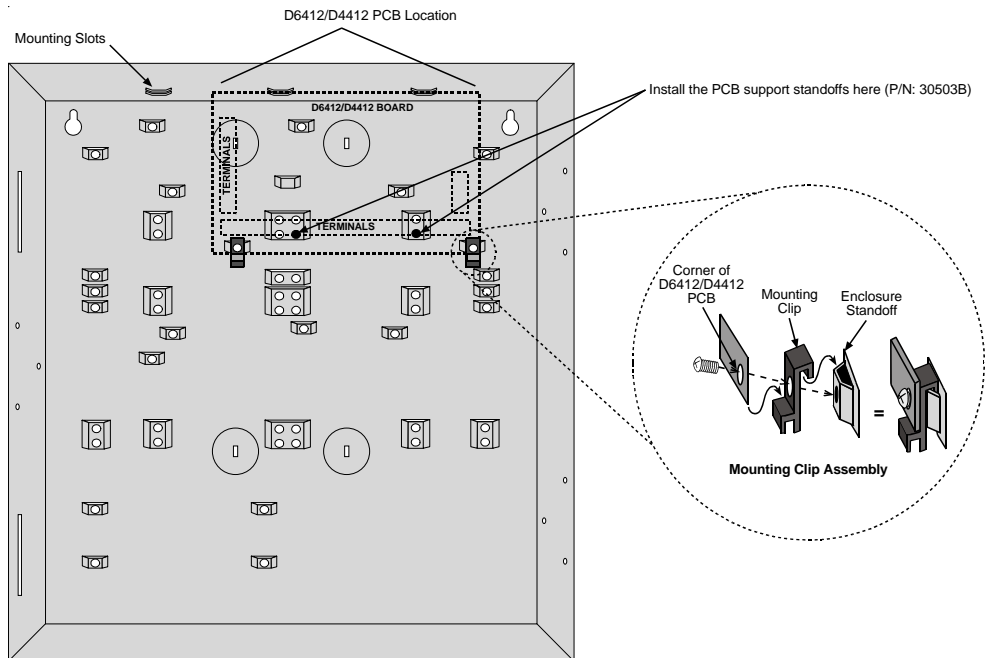

Figure 2: Enclosure Mounting

#### 3.4.1 Connecting Earth Ground

To help prevent damage from electrostatic charges or other transient electrical surges, connect the system to earth ground before making any other connections. A grounding rod or cold water pipe are recommended earth ground references.

**Do not use telephone or electrical ground for the earth ground connection. Use 14 to 16 AWG (1.8 mm to 1.5 mm) wire when making the connection. Use only the earth ground terminal. Do not connect any other panel terminals to earth ground.**

#### 3.4.2 Closing the Installer Switch

Closing the Installer Switch disables the panel (see *Figure 3*). System reporting is disabled and the system cannot be armed. A system trouble shows at all keypads.

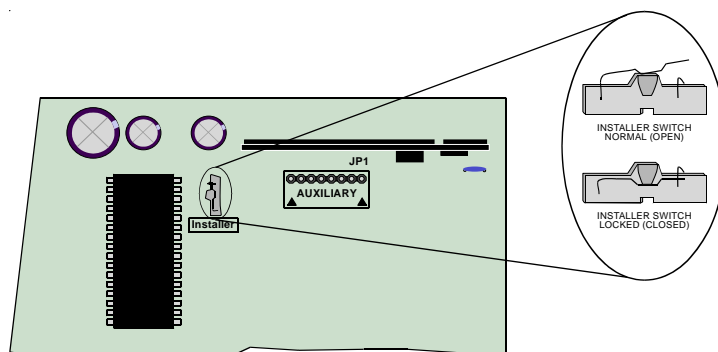

Figure 3: Installer Switch



Opening the Installer Switch from the closed position resets the panel. The panel resets all its timers, counters, indexes, and buffers. Any points that restore after a reset is performed do not generate Restoral Reports.

Leaving the Installer Switch in the closed position lets you power up the panel and charge the battery as you install the detection devices and command centers.

### 3.5 Finishing the Installation

#### 3.5.1 Earth Ground and Installer Switch

First, make the earth ground connection and close the Installer Switch if you have not already done so.

To reduce the occurrence of false alarms upon toggling of the Installer Switch, the panel ignores all point faults while the devices stabilize during the setup process. The panel's start-up process takes approximately 60 sec. to complete. It occurs at power-up and when the panel resets (Installer Switch OPEN). See *Section 3.5.7 Power Up* and *Section 13.3.10 Exiting the Installer's Menu* for more information. During this period, a screen showing the panel model number (D6412 or D4412), firmware revision number, and a "Please Wait..." message appears for approximately 10 seconds.

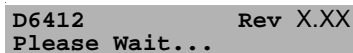

D6412 Rev X.XX  
Please Wait...

#### 3.5.2 Charge the Battery as You Finish

Connect the battery and then the transformer so that the panel can charge the battery as you finish the installation. See *Section 4.0 Power Supply* for instructions.

**Self-Diagnostics at Power Up and Reset:** The system performs a series of self-diagnostic tests of its hardware, software, and program at power up and at reset. They take about 60 sec. to complete. Command centers may display "System Fault" and sound during the power up and reset interval.

If the panel fails any of the tests, a system trouble message appears at the command centers.

**Touch the Earth Ground Terminal First:** To discharge any static charge you may be carrying, always touch the panel's earth ground terminal before beginning work on the panel.

#### 3.5.3 Install and Wire Detection Devices

Install and wire detection devices and command centers at their locations throughout the premises. **Do not** make the connections at the panel end of the wiring yet.

*Section 7.0 On-Board Sensor Loops* contains instructions for wiring the on-board point locations to detection devices. *Section 11.0 Arming Devices* contains instructions for wiring the command centers.

Instructions for wiring the off-board point locations are found in the instructions packaged with the point expansion devices.

#### 3.5.4 Install Modules

1. **Power Down First:** Power down the unit by unplugging the transformer and disconnecting the battery. Bosch Security Systems recommends powering down the unit when installing modules or when making wiring connections to the panel.
2. Install and wire any modules required for your installation as described in the module's installation instructions.

Instructions for the DX2010 Point Expansion Module and the DX3010 Output Expansion Module are included in this guide. See *Section 8.0 Off-Board Sensor Loops* for DX2010 instructions and *Section 10.0 Off-Board Outputs* for DX3010 instructions.

#### 3.5.5 Make the Telephone Connections

If you are connecting the panel to a ground start phone system, you need to install a D133/D134 Relay. See *Section 6.0 Telephone Connections* for complete instructions.

#### 3.5.6 Connect the On-Board Points and Command Centers

Connect the on-board points and command center wiring to the system. See *Section 7.0 On-Board Sensor Loops* and *Section 11.0 Arming Devices* for instructions.

## Installation

### 3.5.7 Power Up

Reconnect the battery and then plug in the transformer.

Leave the Installer Switch in the CLOSED position for now. (See *Figure 3*). The following sequence of events occurs:

1. "System Fault" appears on the text command center(s) and all command centers emit a single tone for approximately 10 seconds.
2. A screen showing the panel model number (D6412 or D4412), firmware revision number and a "Please Wait..." message appears for approximately 10 seconds.
3. "Trouble! Press Cmd 4 to View" appears. Press the [CMD] and [4] keys. A new message appears: "Date/Time lost! Press 5 to set." Press the [5] key to enter the Date/Time window and set accordingly.

To reduce the occurrence of false alarms upon panel power-up (or restoration of power after a complete loss of primary and secondary power), the panel ignores all point faults for approximately 60 sec. while the devices stabilize. This process is part of the panel's start-up process, and it occurs at power-up. This 60-sec. period begins when the "Please Wait..." screen appears.

The "Trouble! Press Cmd 4 to View" message reappears, indicating that the Installer Switch is closed. To return the system to normal (disarmed, no fault/trouble conditions), open the Installer Switch (unless you are ready to program the panel).

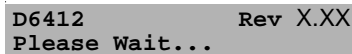

```
D6412          Rev X.XX
Please Wait...
```

### 3.6 Programming the Panel

If you have not created a program for the panel, review the *D6412/D4412 Program Entry Guide* (P/N: 45351). Make certain you have all the required accessory modules installed for the features you want to use.

**Note:** *The Installer Switch must be in the closed position to program the panel from a keypad.*

You can enter your custom program at a text keypad, or send it to the panel from the Remote Account Manager (RAM IV). There is a connector provided on the panel for quick connection of an installer's keypad to the system for programming. See *Section 13.0 Installer's Keypad and Installer Mode* for complete instructions for the installer keypad.

After you finish programming, move the Installer Switch to the open position. If the unit is programmed for reporting, the panel transmits a Reboot Report to the receiver.

### 3.7 Check for Fire Alarm Verification

You must check the Alarm Verification Box in the lower left corner of the label if you programmed Point 1 for Fire with Verification. See *Point Index* in the *D6412/D4412 Program Entry Guide* (P/N: 45351). Refer to *Section 14.0 Installation Label* for the location of the Alarm Verification Box on each installation label.

### 3.8 Testing the System

After finishing the installation and programming of the panel, make a complete functional test of the system. Test the panel and all devices for proper operation. Test after you first program the panel and after any subsequent programming session.

**Walk Test:** Use the Walk Test (Cmd 44) or the point test available in the Installer Mode to perform a complete test of the panel. See *Section 13.0 Installer's Keypad and Installer Mode*.

If you test a device and the panel does not respond, there may be a problem with the device, wiring, a module setting, or programming for the point.

**Clear After Test:** To clear the event memory and report buffer, momentarily close the Installer Switch. Events stored in the panel's event log are not cleared.

## 4.0 Power Supply

### 4.1 Primary Power

#### 4.1.1 Primary (AC) Power Circuit

An 18 VAC, 22 VA internally fused transformer (Bosch Security Systems CX4010) is the primary power source. The AC power circuit provides 700 mA of rectified AC power. The panel reserves 100 mA of this power for internal operations, leaving 600 mA for powered devices.

Transient suppressors and spark gaps protect the circuit from power surges. This protection relies on the panel's earth ground connection. Make sure you connect the earth ground terminal to a proper ground. See *Section 3.4.1 Connecting Earth Ground*.

The system indicates an AC power failure when the power at the terminals marked "18 VAC" is interrupted. Power must be missing for 120 sec. before the panel acknowledges the failure. Power must be maintained at those terminals for 120 sec. before the panel acknowledges the restoration of power.

#### 4.1.2 Installing the Transformer



CAUTION

*Shorting the terminals for prolonged periods of time may cause permanent damage. Connect the transformer to the panel terminals before plugging it into the power source.*



IMPORTANT

*Bosch Security Systems recommends that you always connect the battery first and then plug in the transformer. See Section 4.2.2 Installing the Battery for more information.*

Use 18 AWG (1.2 mm) (minimum) wire to connect the transformer to the panel. Wire length should be kept as short as possible. The maximum length is 15.2 m (50 feet).

AC wiring can induce both noise and low level voltage into adjacent wiring. Route phone and sensor loop wiring away from any AC conductors, including the transformer wire. Route data wiring away from AC and phone wiring.

Only plug the transformer into an unswitched, 120 VAC, 60 Hz power outlet. Secure the transformer to the outlet with the screw provided.

## 4.2 Secondary Power

### 4.2.2 Installing the Battery

Place the battery upright in the base of the enclosure. Locate the red and black leads supplied in the literature pack. Push one connector on the black battery lead to panel's "Batt-" connector, and then push the lead's other connector to the negative (-) side of the battery. Push one connector on the red battery lead to panel's 'Batt+' connector, and then push the lead's other connector to the positive (+) side of the battery.



WARNING

*High Current Arcs Possible: The positive (red) battery lead and the panel's "Batt+" connector can create high current arcs if shorted to terminals or the enclosure. Use caution when working with the positive lead and the panel's "Batt +." Always disconnect the positive (red) lead from the battery before removing it from the panel.*

#### 4.2.3 Replacement

Bosch Security Systems recommends battery replacement every three to five years under normal use. Exceeding the maximum output ratings, or installing the transformer in an outlet that is routinely switched off, causes heavy discharges. Routine heavy discharges can lead to premature battery failure. Record the date of installation directly on the battery.

#### 4.2.4 Battery Supervision

When the battery drops to 12.1 VDC, the panel (if programmed for power supervision) transmits a Battery Low Report. If the battery is missing or shorted and the panel is programmed for power supervision, it transmits a Battery Missing Report.

When battery voltage returns to 13.0 VDC, the panel (if programmed for power supervision) transmits a Battery Restoral Report.

## Power Supply



*Investigate low battery reports immediately: If primary (AC) power is off and the discharge continues, the panel becomes inoperative when the battery voltage drops below 10.2 VDC.*

### 4.2.5 Battery Charging Circuit - Float Charge

The float voltage for the battery charging circuit is 13.5 VDC to 13.9 VDC at a maximum current of 1.4 A.

### 4.2.6 Battery Discharge/Recharge Schedule

#### Discharge Cycle

- AC Off: Command centers indicate trouble. AC Fail Report sent as programmed.
- 13.8 VDC: Charging float level
- 12.1 VDC: Low battery trouble at command centers. Low Battery Report as programmed.
- 10.2 VDC: Panel shuts down as voltage falls below 10.2 VDC

#### Recharge Cycle

- AC On: Panel restarts, battery charging begins, AC Restoral Report sent as programmed, AC trouble clears from command centers.
- 13.0 VDC: Battery restoral reports sent, battery trouble clears from command centers
- 13.8 VDC: Battery float charged.

### 4.2.7 System Status LED

The System Status LED shows system status, including power supply status as described in *Table 4*. See *Figure 4* for the location of the LED on the panel.

System Status	LED Display
System Normal	On for 50 ms; Off for 1 sec.
Battery Missing	Off for 200 ms; On for 1 sec.
AC Missing	Off for 200 ms; On for 200 ms Off for 200 ms; On for 1 sec.
Phone Ringing	Flickers for 1 sec. as each ring is detected.
Phone Line Seized (panel using phone line)	On solid.
Shut Down (system voltage below 10.2 VDC)	Off for 200 ms; On for 200 ms Off for 200 ms; On for 200 ms Off for 200 ms; On for 1 sec.

Table 4: System Status LED Description

### 4.3 External Power Supply

The external power supply (not supplied) is not intended to provide power to indicating devices for burglary and fire applications.

- **Burglary Applications** use a UL603 Listed burglar alarm power supply with an operating voltage range of 11.8 VDC to 12.4 VDC for Bank Safe/Vault applications (72 hrs. of standby battery required).
- **Fire Applications** use a UL1481 Listed power supply operating voltage range of 11.8 VDC to 12.4 VDC for fire applications.

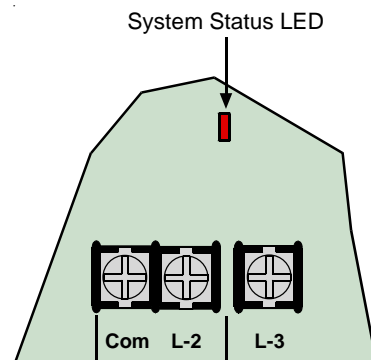

Figure 4: System Status LED

## 5.0 Power Outputs

### 5.1 Circuit Protection

Three self-resetting thermal circuit breakers protect the panel from short circuits on both the continuous and programmable power outputs. If the panel is programmed for power supervision and a short is sustained on one of the power outputs, the panel transmits a Battery Low or Battery Missing Report.

One breaker protects Auxiliary Power and the Installer's Keypad Connector; a short on one disrupts power to the other.

One breaker protects the Alarm Power Output (Alrm + Terminal) and one breaker protects the battery.

### 5.2 Available Power

#### 5.2.1 Auxiliary Power

Use the auxiliary power terminals to power devices requiring continuous power. See *Section 14.0 Installation Label* and *Section 15.0 Terminal Quick Reference* for the location and description of these terminals.

#### 5.2.2 Installer's Keypad Connector

Use this connector to connect an installer's keypad to the panel for programming and diagnostics.

#### 5.2.3 Alarm Power

Provides positive 12 VDC for Programmable Output 2 (PO2 ) when it is configured as a siren driver and Programmable Output 1 (PO1) when it is configured as the alarm output.

### 5.3 Continuous Power Output

#### 5.3.1 Continuous Current Draw

The **continuous** current draw for powered devices connected to the Aux Power terminals, Installer's Keypad Connector, and Outputs PO1 to Programmable Output 4 (PO4 ), when programmed for continuous output, are restricted as follows:

- 120 mA for Fire and Combined Fire/Burglary systems
- 400 mA for UL Burglary systems
- 600 mA for other applications (not investigated by UL)

### 5.4 Alarm Power

#### 5.4.1 Available Power

The system combines the 600 mA of primary power produced by the power supply with the secondary power source (the battery) to produce a total of 1.5 A of **alarm** power at 11.5 VDC to 12.4 VDC. Alarm power is available at the Alrm + terminal. The panel uses PO1 through PO4 to activate Alarm power (see *Section 5.5 Output Programming*).



***Fire systems are prohibited from using the battery for determining alarm power. Use the Fire System Power Formula below to calculate the current available for fire and combined fire/burglary systems.***

#### Fire System Power Formula

To calculate the current available at the Alrm + terminal for fire and combined fire/burglary systems:

1. Add together the current draws for all devices connected to the Aux terminals and the Installer's Keypad Connector. This total is the total current required for the Normal Standby Condition (NSC).
2. The current available for NSC is 600 mA. Subtract the NSC current required calculated in Step 1 from the NSC current available, 600 mA. The difference is the Alarm Current available the Alrm + terminal (480 mA maximum).

**Formula format:** 600 mA – NSC current required (Step 1) = Alarm Current available (480 mA maximum)

Refer to *A-4: Current Rating Chart for Standby Battery Calculations* for module/accessory current requirements.

## Power Outputs

### 5.5 Output Programming

Programmable Output 2 (PO2) can be configured as a supervised siren driver. See *Global Output Configuration* in the *D6412/D4412 Program Entry Guide* (P/N: 45351) for programming instructions. When programmed as a siren driver, PO2 draws power from the Alarm + terminal. When connected to a 4 Ω horn/speaker, PO2 draws 380 mA of power. When connected to an 8 Ω horn/speaker, it draws 330 mA of power. Use the appropriate current draw in your total alarm power calculation.

- **Programmable Output 1 (PO1):** PO1 terminals can be configured as an alarm power output. JP2-PO1 Jumper must be closed. The default configuration for Programmable Output 1 makes it a dry contact, normally open relay. The PO1 Jumper is open. See *Figure 5* for jumper location.
- **Programmable Output 2 (PO2):** Output PO2 can be used with Alarm+ as a supervised siren driver. Connect an approved 4 or 8 Ω siren. Alternatively, PO2 can sink up to 500 mA 12 VDC. For larger loads, use a Bosch Security Systems D133 Relay Module or Bosch Security Systems D134 Dual Relay Module.
- **Programmable Outputs 3 and 4 (PO3 and PO4):** Outputs PO3 and PO4 can be configured for Alarm Output. These outputs can sink up to 500 mA 12 VDC each. For larger loads, use a Bosch Security Systems D133 Relay Module or Bosch Security Systems D134 Dual Relay Module.

**Power restricted for fire and combined fire/burglary systems:** Use the Fire System Power Formula in *Section 5.4.1 Available Power* to calculate the current available for fire and combined fire/burglary systems.

**Unexpected Output at PO1 to PO4:** If these outputs do not provide the alarm output you expect:

- Check the programming for Programmable Outputs in the *Outputs* section of the *D6412/D4412 Program Entry Guide* (P/N: 45351).
- Check the Point Index Configuration section of the *D6412/D4412 Program Entry Guide* to verify the points you are activating are programmed for alarm output.

 **If Programmable Output 2 is configured as a supervised siren driver (in combination with the Alarm + terminal), you must connect a 4 Ω or 8 Ω siren/speaker to PO2 to clear the siren/speaker supervision trouble.**

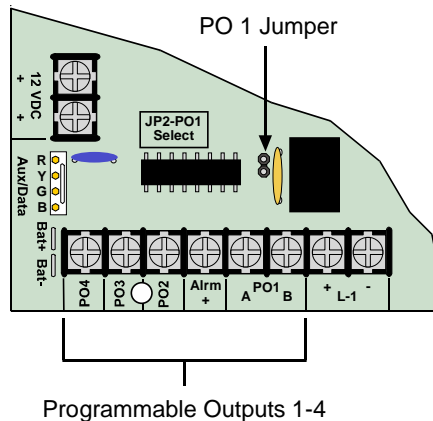

Figure 5: On-Board Outputs

## 6.0 Telephone Connections

### 6.1 Registration

The Bosch Security Systems D6412/D4412 Control Panel is registered with the Federal Communication Commission (FCC) under Part 68 for connection to the public telephone system using an RJ31X or RJ38X jack installed by your local phone company.

### 6.2 Notification

Do not connect registered equipment to party lines or coin-operated telephones. You must notify the local telephone company and supply them with the following information before connecting the panel to the telephone network.

- Line to which you are connecting the panel
- Make (Bosch Security Systems), model (D6412 or D4412), and serial number of the panel
- FCC registration number: ESVMUL-46531-AL-E
- Ringer equivalence for the panel: 0.1 B

### 6.3 Location

To prevent jamming of signals, wire the RJ31X jack or RJ38X jack to support line seizure as shown in *Figure 6*. Install the jack on the street side of the phone switch, wired ahead of any PBX equipment. Line seizure temporarily interrupts normal phone usage while the communicator transmits data. After installation, confirm that the panel seizes the line, acquires dial tone, reports correctly to the receiver, and releases the phone line to the in-house phone system.

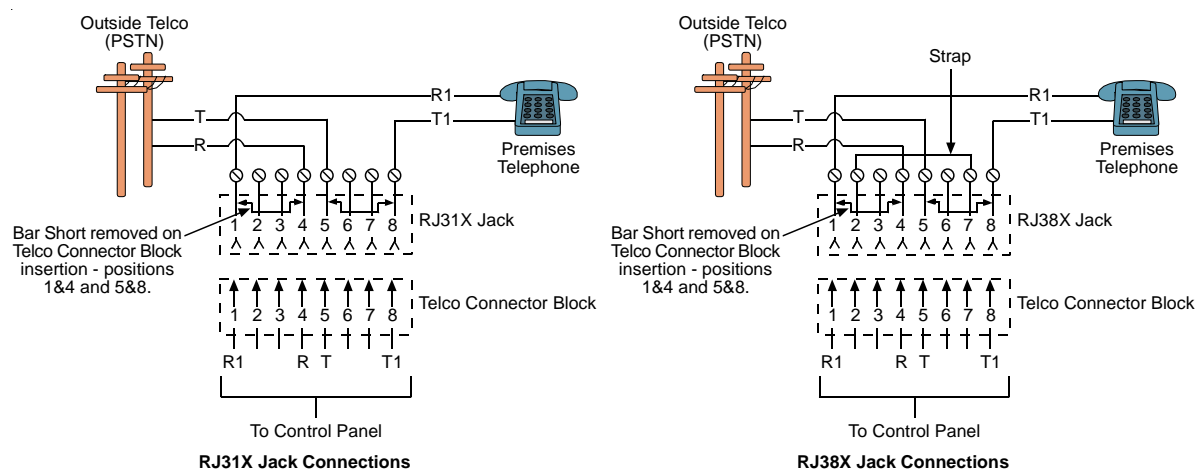

Figure 6: RJ31X/RJ38X Wiring

### 6.4 Phone Cord Connection

Connect the flying leads of a D164 Telephone Cord to the telephone terminals labeled **R**, **R1**, **T1**, and **T**. The terminals are located on the right side of the panel. Connect the other end of the cord to the RJ31X jack or RJ38X jack.

### 6.5 System Status LED (Red)

The System Status LED shows system status, including phone status as described in *Table 4*. *Figure 4* shows the location of the LED on the panel.

### 6.6 Dialing Format

You can program the system to use DTMF or pulse dialing. See *DTMF/Pulse Dialing* in the *D6412/D4412 Program Entry Guide* (P/N: 45351).

## Telephone Connections

### 6.7 Phone Line Fault

The panel has a circuit that tests the phone line for voltage. Normal voltage on a telephone line is approximately 48 VDC (24 VDC for some phone systems). The phone line monitor senses trouble when voltage drops low enough (between 1 V and 3 V).

If the panel senses trouble, it starts a phone line trouble timer that continues to run as long as the panel senses trouble. It resets to zero when the panel senses a normal line. If the timer reaches 40 sec., it begins a phone line trouble response. Programming determines what the response is. See *Phone Line Fault Response Options* in the *D6412/D4412 Program Entry Guide* (P/N: 45351).

**Bad line may test OK:** The telephone line test circuit uses the voltage level to test the status of the phone line. In some instances, a given telephone line may be out of service without affecting the voltage on the line. The phone line monitor can not recognize this trouble condition.

### 6.8 Called Party Disconnect

Telephone companies provide “called party disconnect” to allow the called party to terminate a call. The called party must go on-hook (hang up) for a fixed interval before a dial tone is available for a new call. This interval varies with telephone company equipment. The panel provides “called party disconnect” by adding a 35 sec. on hook interval to the dial tone detect function. If the panel does not detect a dial tone in 7 sec., it puts the phone line on hook for 35 sec. to activate “called party disconnect,” goes off hook and begins a seven-second dial tone detect. If no dial tone is detected, the panel dials the number anyway. Each time the number is dialed, the panel records this as an attempt.

### 6.9 Communication Failure

The panel routes reports to two routing destinations, each of which can be programmed with two phone numbers. See *Appendix A: Routing Dialing Tables* in the *D6412/D4412 Program Entry Guide* (P/N: 45351). Numbers in [ ] are the numbers assigned to panel events. For more panel event information, see *Appendix B* in the *D6412/D4412 Program Entry Guide*.

The Routing Dialing tables show the circumstances when Communication Failure Events are created. When a Comm Fail occurs, the D6412/D4412 responds as follows:

1. Clear (dump) the initiating report and any pending reports from the dialer buffer for the destination where the Comm Fail Event occurred.
2. Create a Comm Fail [69] Report or Alt Comm Comm Fail [70] Report that includes the Destination Number (1 or 2). Modem IIIa<sup>2</sup> Reports report the destination number as a Route Group (RG). The Alternate Comm Fail Report is used when an alternate communications path is used (e.g., SAFECOM).
3. Comm Fail, Comm Restoral [71], and Alternate Comm Restore [72] Reports follow the System Status Reports routing.
4. If the Comm Fail occurred on Destination 1 and System Status Reports routing is set to Destination 2 or set to Destination 2 on Destination 1 fail, then send Comm Fail Report.
5. If the Comm Fail occurred on Destination 1 and System Status Reports routing is set to Destination 1 then send a Comm Restore Report with the next report for destination 1.
6. If the Comm Fail occurred on Destination 2 and System Status Reports routing is set to Destination 1, then send Comm Fail Report.
7. If the Comm Fail occurred on Destination 2 and System Status Reports routing is set to Destination 2 then send a Comm Restore Report with the next report for destination 2.
8. If a Comm Fail Report is sent successfully to the other destination, a Comm Restore Event should be sent when there is a successful communication on the failed destination.

### 6.10 Ground Start

Some telephone systems require a momentary ground input to initiate a dial tone. To interface with a ground start system, you must wire PO1 as shown in *Figure 7*. PO1 Jumper must be open.

#### 6.10.1 Program PO1 for Ground Start

See *Outputs* of the *D6412/D4412 Program Entry Guide* (P/N: 45351) for programming instructions. PO2, PO3, and PO4 can be used to interface with a ground start system using a D133 Relay Module or a D134 Dual Relay Module. The PO1 jumper is not used when interfacing PO2, PO3, or PO4 to a D133 or D134. See *Figure 7* for details.



Telephone Connections



You must connect a proper earth ground reference to the earth ground terminal.



Ground start not for use in Fire or combined Fire/Burglary applications. You can not use ground start telephone systems for Fire or combined Fire/Burglary applications.

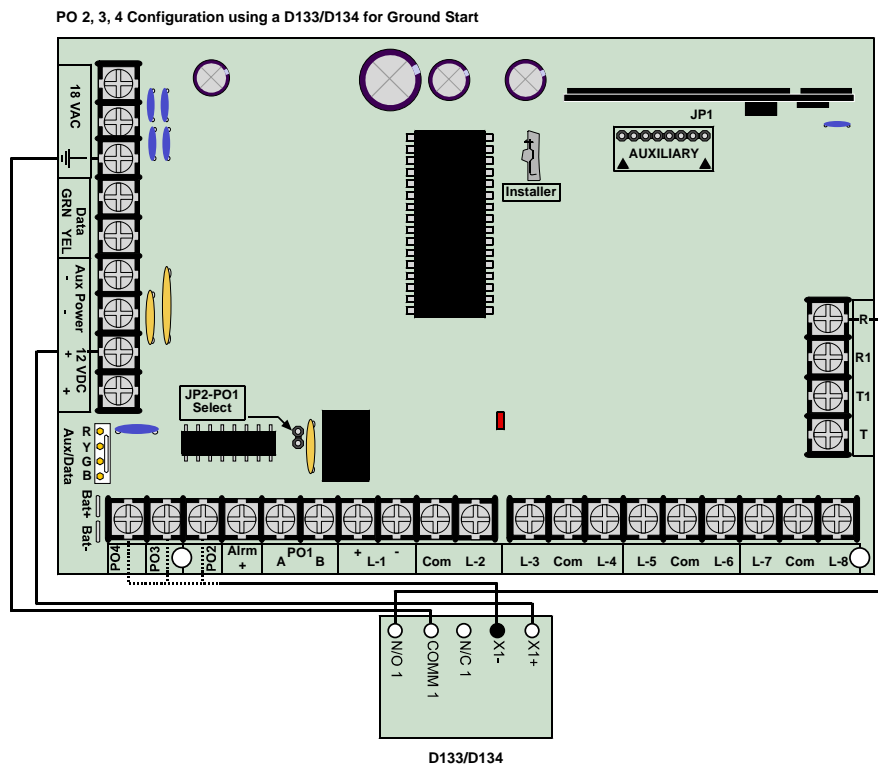
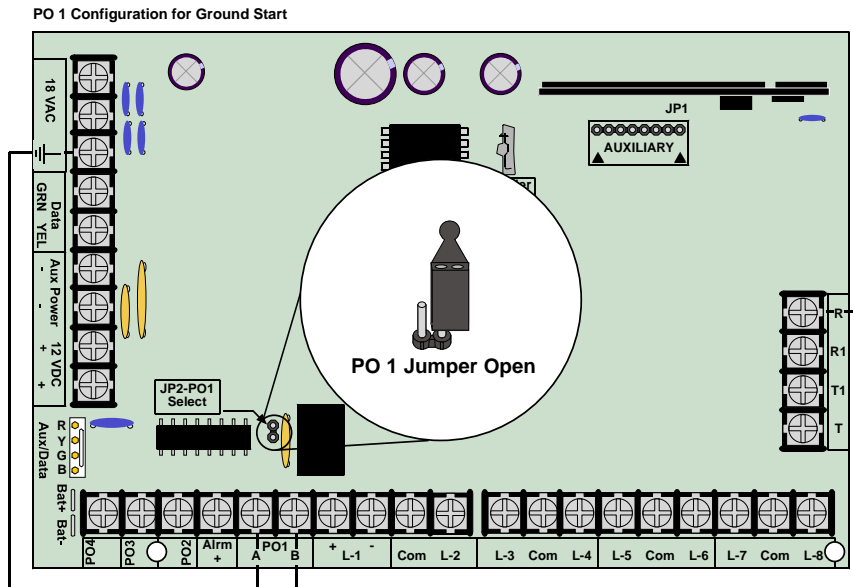

Figure 7: Ground Start

**Notes:**

## 7.0 On-Board Sensor Loops

### 7.1 Description

The panel provides eight on-board sensor loops, each of which functions independently and does not interfere with the operation of the others. On-board sensor loops can be set to the default single point configuration with a 2.2 k $\Omega$  End of Line (EOL) resistor, a single point configuration with 1 k $\Omega$  EOL resistor, a single point configuration with a 3.65 k $\Omega$  EOL resistor, or in a doubled point configuration that utilizes two resistors per sensor loop, one 2.2 k $\Omega$ , and one 3.65 k $\Omega$ . The panel monitors two points per sensor loop in the doubled configuration, making 15 on-board points available See *Section 7.6 Doubled Point Configuration*.

The panel monitors the sensor loops for normal, shorted, or open conditions. Point programming determines how the panel responds to those conditions. See the *D6412/D4412 Program Entry Guide* (P/N: 45351) for point programming options.

The panel ignores sensor loops (both on-board and off-board) for 60 sec. after power up to ensure that any connected devices have stabilized.

### 7.2 Two-wire Smoke Detector Configuration

Sensor Loop 1 can be used as a fire point for connection of two-wire smoke detectors (see *Figure 8*). This sensor loop **cannot** be used for point doubling and must terminate a 2.21 k $\Omega$  EOL resistor (P/N: 25899). See the *D6412/D4412 TSN: Smoke Detector Compatibility* (P/N: 46928) for compatible smoke detectors and the maximum number of devices allowed on Sensor Loop 1.

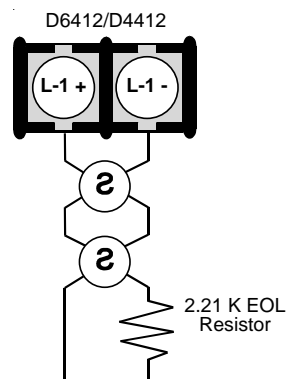

Figure 8: Typical Two-Wire Smoke Detector Wiring

### 7.3 Four-wire Smoke Detector Configuration

A four-wire smoke detector can be connected to any of the panel's on-board sensor loops (L-1 to L-8). A four-wire smoke detector requires the use of a relay module to interrupt power to the detector in order for the detector to reset.

The output controlling the relay must be configured as Output Function 1, 13 (Fire Verification). For more information, refer to the *Outputs* section of the *D6412/D4412 Program Entry Guide* (P/N 45351).

If Sensor Loops 2 to 8 (L-2 to L-8) are used, make positive (+) connections to L-X + (where X = Loop #) and negative (-) connections to the loop's "COM" terminal.

See *Figure 9*.

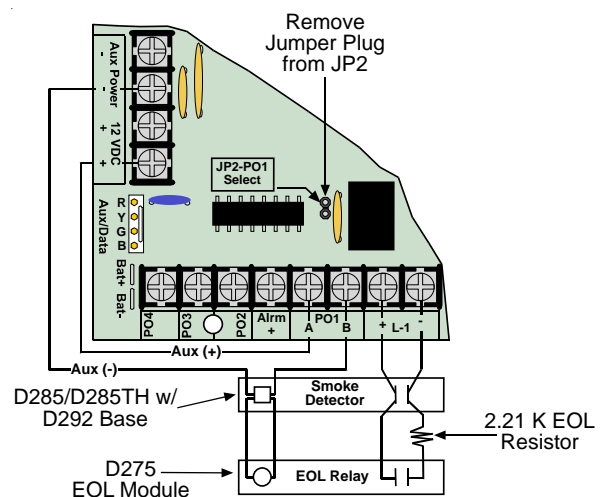

Figure 9: Typical Four-Wire Smoke Detector Wiring

## On-Board Sensor Loops

### 7.4 Sensor Loop 1 Configuration

Sensor Loop 1 (see *Figure 10*) can be used for applications other than a fire point. This sensor loop **cannot** be used for point doubling and must be terminated with a 2.21 kΩ EOL resistor (P/N: 25899).

Loop resistance limits the number of Normally-Open and/or Normally-Closed detection devices each sensor loop can supervise. The total resistance for wire length and contacts, minus the EOL resistor, must not exceed 100 Ω.

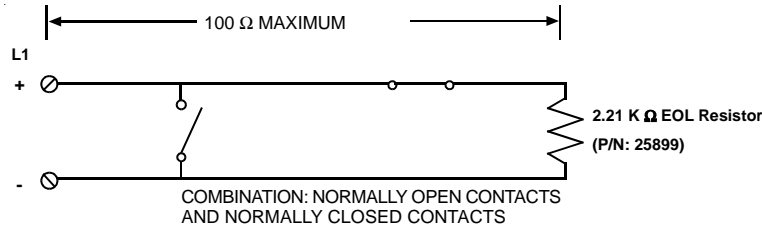

Figure 10: Sensor Loop 1 Wiring

### 7.5 Single Point Configuration (Points 2 to 8)

When wiring the on-board sensor loops in the single point configuration, install the resistor with the appropriate value (2.2 kΩ and 3.65 kΩ are provided) at the far end of the sensor loop to provide a reference for supervision. You can connect dry contact sensing devices in series (normally-closed) and/or in parallel (normally-open) to any of these loops (see *Figure 11*).

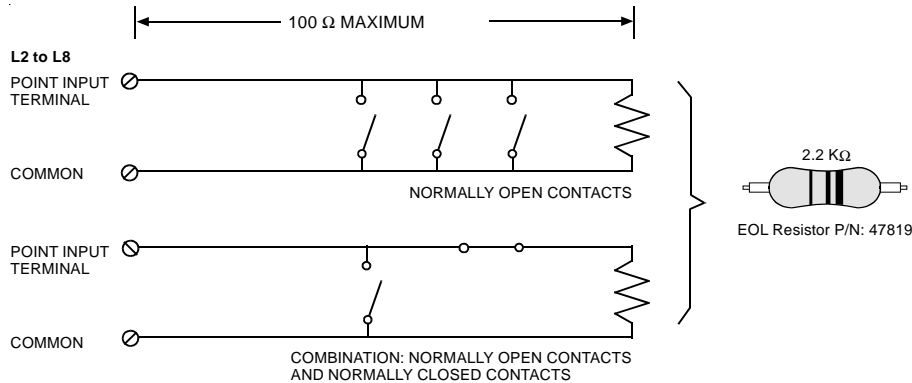

Figure 11: Single Point Sensor Loop Wiring

The number of normally-open and/or normally-closed detection devices each sensor loop can supervise is limited only by the resistance on the loop. The total resistance for wire length and contacts, minus the EOL, must not exceed 100 Ω.

You can determine the condition of the on-board sensor loops in the default configuration (single point, 2.2 kΩ EOL resistor) by measuring the voltage across the point input terminal and one of the common terminals. The sensor loops must be connected and the 2.2 kΩ EOL resistor in place.

Table 5 shows the on-board sensor loops for D6412/D4412 Loops 2 through 8.

EOL Resistor	Open Loop	Normal Loop	Shorted Loop
2.21 K	Greater than 7.7 VDC	Greater than 6.3 VDC, less than 7.3 VDC	Less than 6.0 VDC
3.65 K	Greater than 9.1 VDC	Greater than 7.7 VDC, less than 8.6 VDC	Less than 7.3 VDC
1.0 K	Greater than 5.0 VDC	Greater than 3.8 VDC, less than 4.7 VDC	Less than 3.5 VDC

Table 5: On-Board Sensor Loops

### 7.6 Doubled Point Configuration

When wiring the on-board sensor loops in the doubled point configuration, install the resistors of the appropriate value (2.2 kΩ and 3.65 kΩ) as shown in *Figure 12*.

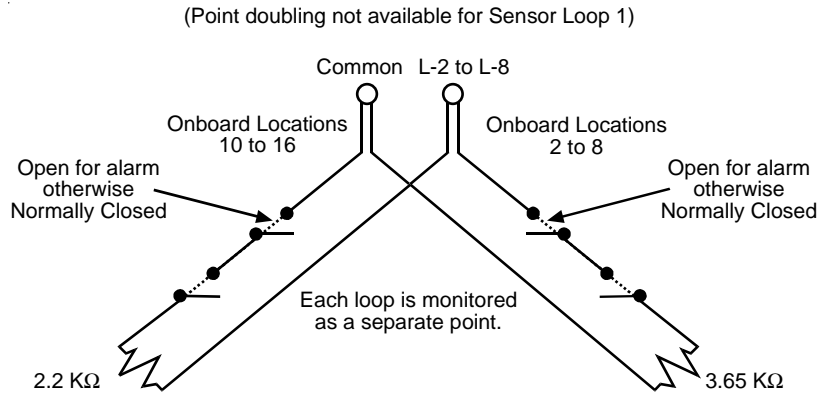

Figure 12: On-Board Doubled Point Sensor Loop Wiring

### 7.7 Sensor Loop Response Time

The panel scans both on and off-board sensor loops per Point Index programming. See *Point Index Configuration* in the *D6412/D4412 Program Entry Guide* (P/N: 45351).

The panel scans sensor loops for ‘pulses’ (electrically off normal events). The Point Index determines the Pulse Count and Pulse Count Time for each sensor loop. If the panel sees enough pulses within an interval defined by the Pulse Count Time to reach the Pulse Count, it puts the sensor loop in a faulted condition.

The panel scans the sensor loops at one of two scan rates as shown in *Table 6*.

Pulse Count Time Selections for 50 ms Point Scan Time (on-board points only)		Pulse Count Time Selections for 160 ms Point Scan Time (off-board points only)	
Selection	Actual Pulse Count Time	Selection	Actual Pulse Count Time
0	0.5 sec.	8	20 sec.
1	1 sec.	9	30 sec.
2	2 sec.	10	40 sec.
3	3 sec.	11	50 sec.
4	4 sec.	12	60 sec.
5	5 sec.	13	90 sec.
6	10 sec.	14	120 sec.
7	15 sec.	15	200 sec.

Table 6: Point Scan Time/Pulse Count Time Selections

The scan rates for off-board sensor loops are determined by the point expansion modules they are associated with. The panel scans modules with off-board points at the 150 ms scan rate.



**Increasing the Pulse Count and Pulse Count Time may cause missed alarms. If you increase the Pulse Count and Pulse Count Time, detection devices may go into alarm and reset without exceeding the Pulse Count or Pulse Count Time.**

**Bosch Security Systems recommends using the default settings for Pulse Count and Pulse Count Time.**

**Notes:**

## 8.0 Off-Board Sensor Loops

### 8.1 SDI Point Expanders

You can expand the number of points on the panel by connecting modules to the panel's SDI (data) Bus. Use the DX2010 Point Expansion module to add wired points. Use a compatible Premises RF Receiver to add wireless points. *Table 7* shows how point expansion devices map to the panel's point locations. See the *Locations* section in the *D6412/D4412 Program Entry Guide* (P/N: 45351) for a description of the relationship between locations and points.

The panel ignores sensor loops (both On-Board and Off-Board) for 60 sec. after power up to ensure that any connected devices have stabilized.

Location #	Location Parameters				Device Parameter Selections				
	Device (default)	Pt. Index (default)	Area (default)	Point # (default)	1 On-board	2 D9628	3 DX2010, doubled	4 RF Receiver 1	5 RF Receiver 2
1	Nibble 0706 (1)	Nibble 0707 (1)	Nibble 0708 (1)	Nibble 0709-0710 (0-1)	2.2 K $\Omega$ only	SDI Addr 101 Loop 1, 2.2 K $\Omega$		SDI Addr 50 Transmitter 1	SDI Addr 51 Transmitter 1
2	Nibble 0711 (1)	Nibble: 0712 (11)	Nibble: 0713 (1)	Nibble: 0714-0715 (0-2)	3.65 K $\Omega$ when doubled w/ 10	SDI Addr 101 Loop 2, 2.2 K $\Omega$		SDI Addr 50 Transmitter 2	SDI Addr 51 Transmitter 2
3	Nibble 0716 (1)	Nibble 0717 (11)	Nibble 0718 (1)	Nibble 0719-0720 (0-3)	3.65 K $\Omega$ when doubled w/ 11	SDI Addr 101 Loop 3, 2.2 K $\Omega$		SDI Addr 50 Transmitter 3	SDI Addr 51 Transmitter 3
4	Nibble 0721 (1)	Nibble 0722 (13)	Nibble 0723 (1)	Nibble 0724-0725 (0-4)	3.65 K $\Omega$ when doubled w/ 12	SDI Addr 101 Loop 4, 2.2 K $\Omega$		SDI Addr 50 Transmitter 4	SDI Addr 51 Transmitter 4
5	Nibble 0726 (1)	Nibble 0727 (13)	Nibble 0728 (1)	Nibble 0729-0730 (0-5)	3.65 K $\Omega$ when doubled w/ 13	SDI Addr 101 Loop 5, 2.2 K $\Omega$		SDI Addr 50 Transmitter 5	SDI Addr 51 Transmitter 5
6	Nibble 0731 (1)	Nibble 0732 (14)	Nibble 0733 (1)	Nibble 0734-0735 (0-6)	3.65 K $\Omega$ when doubled w/ 14	SDI Addr 101 Loop 6, 2.2 K $\Omega$		SDI Addr 50 Transmitter 6	SDI Addr 51 Transmitter 6
7	Nibble 0736 (1)	Nibble 0737 (14)	Nibble 0738 (1)	Nibble 0739-0740 (0-7)	3.65 K $\Omega$ when doubled w/ 15	SDI Addr 101 Loop 7, 2.2 K $\Omega$		SDI Addr 50 Transmitter 7	SDI Addr 51 Transmitter 7
8	Nibble 0741 (1)	Nibble 0742 (4)	Nibble 0743 (1)	Nibble 0744-0745 (0-8)	3.65 K $\Omega$ when doubled w/ 16	SDI Addr 101 Loop 8, 2.2 K $\Omega$		SDI Addr 50 Transmitter 8	SDI Addr 51 Transmitter 8
9	Nibble 0746 (0)	Nibble 0747 (0)	Nibble 0748 (1)	Nibble 0749-0750 (0-9)	Not available as double pt.	SDI Addr 102 Loop 1, 2.2 K $\Omega$	SDI Addr 106 Loop 1, 3.65 K $\Omega$	SDI Addr 50 Transmitter 9	SDI Addr 51 Transmitter 9
10	Nibble 0751 (0)	Nibble 0752 (0)	Nibble 0753 (1)	Nibble 0754-0755 (1-0)	Doubled w/ 2, 2.2 k $\Omega$	SDI Addr 102 Loop 2, 2.2 K $\Omega$	SDI Addr 106 Loop 2, 3.65 K $\Omega$	SDI Addr 50 Transmitter 10	SDI Addr 51 Transmitter 10
11	Nibble 0756 (0)	Nibble 0757 (0)	Nibble 0758 (1)	Nibble 0759-0760 (1-1)	Doubled w/ 3, 2.2 K $\Omega$	SDI Addr 102 Loop 3, 2.2 K $\Omega$	SDI Addr 106 Loop 3, 3.65 K $\Omega$	SDI Addr 50 Transmitter 11	SDI Addr 51 Transmitter 11
12	Nibble 0761 (0)	Nibble 0762 (0)	Nibble 0763 (1)	Nibble 0764-0765 (1-2)	Doubled w/ 4, 2.2 K $\Omega$	SDI Addr 102 Loop 4, 2.2 K $\Omega$	SDI Addr 106 Loop 4, 3.65 K $\Omega$	SDI Addr 50 Transmitter 12	SDI Addr 51 Transmitter 12
13	Nibble 0766 (0)	Nibble 0767 (0)	Nibble 0768 (1)	Nibble 0769-0770 (1-3)	Doubled w/ 5, 2.2 K $\Omega$	SDI Addr 102 Loop 5, 2.2 K $\Omega$	SDI Addr 106 Loop 5, 3.65 K $\Omega$	SDI Addr 50 Transmitter 13	SDI Addr 51 Transmitter 13
14	Nibble 0771 (0)	Nibble 0772 (0)	Nibble 0773 (1)	Nibble 0774-0775 (1-4)	Doubled w/ 6, 2.2 K $\Omega$	SDI Addr 102 Loop 6, 2.2 K $\Omega$	SDI Addr 106 Loop 6, 3.65 K $\Omega$	SDI Addr 50 Transmitter 14	SDI Addr 51 Transmitter 14
15	Nibble 0776 (0)	Nibble 0777 (0)	Nibble 0778 (1)	Nibble 0779-0780 (1-5)	Doubled w/ 7, 2.2 K $\Omega$	SDI Addr 102 Loop 7, 2.2 K $\Omega$	SDI Addr 106 Loop 7, 3.65 K $\Omega$	SDI Addr 50 Transmitter 15	SDI Addr 51 Transmitter 15
16	Nibble 0781 (0)	Nibble 0782 (0)	Nibble 0783 (1)	Nibble 0784-0785 (1-6)	Doubled w/ 8, 2.2 K $\Omega$	SDI Addr 102 Loop 8, 2.2 K $\Omega$	SDI Addr 106 Loop 8, 3.65 K $\Omega$	SDI Addr 50 Transmitter 16	SDI Addr 51 Transmitter 16
17	Nibble 0786 (0)	Nibble 0787 (0)	Nibble 0788 (1)	Nibble 0789-0790 (1-7)		SDI Addr 103 Loop 1, 2.2 K $\Omega$	SDI Addr 106 Loop 1, 2.2 K $\Omega$	SDI Addr 50 Transmitter 17	SDI Addr 51 Transmitter 17
18	Nibble 0791 (0)	Nibble 0792 (0)	Nibble 0793 (1)	Nibble 0794-0795 (1-8)		SDI Addr 103 Loop 2, 2.2 K $\Omega$	SDI Addr 106 Loop 2, 2.2 K $\Omega$	SDI Addr 50 Transmitter 18	SDI Addr 51 Transmitter 18
19	Nibble 0796 (0)	Nibble 0797 (0)	Nibble 0798 (1)	Nibble 0799-0800 (1-9)		SDI Addr 103 Loop 3, 2.2 K $\Omega$	SDI Addr 106 Loop 3, 2.2 K $\Omega$	SDI Addr 50 Transmitter 19	SDI Addr 51 Transmitter 19

Table 7: Point Expansion Mapping

Off-Board Sensor Loops

Location #	Device (default)	Pt. Index (default)	Area (default)	Point # (default)	1 On-board	2 D9628	3 DX2010, doubled	4 RF Receiver 1	5 RF Receiver 2	
20	Nibble 0801 (0)	Nibble 0802 (0)	Nibble 0803 (1)	Nibble 0804-0805 (2-0)		SDI Addr 103 Loop 4, 2.2 KΩ	SDI Addr 106 Loop 4, 2.2 KΩ	SDI Addr 50 Transmitter 20	SDI Addr 51 Transmitter 20	
21	Nibble 0806 (0)	Nibble: 0807 (0)	Nibble: 0808 (1)	Nibble: 0809-0810 (2-1)		SDI Addr 103 Loop 5, 2.2 KΩ	SDI Addr 106 Loop 5, 2.2 KΩ	SDI Addr 50 Transmitter 21	SDI Addr 51 Transmitter 21	
22	Nibble 0811 (0)	Nibble 0812 (0)	Nibble 8013 (1)	Nibble 0814-0815 (2-2)		SDI Addr 103 Loop 6, 2.2 KΩ	SDI Addr 106 Loop 6, 2.2 KΩ	SDI Addr 50 Transmitter 22	SDI Addr 51 Transmitter 22	
23	Nibble 0816 (0)	Nibble 0817 (0)	Nibble 0818 (1)	Nibble 0819-0820 (2-3)		SDI Addr 103 Loop 7, 2.2 KΩ	SDI Addr 106 Loop 7, 2.2 KΩ	SDI Addr 50 Transmitter 23	SDI Addr 51 Transmitter 23	
24	Nibble 0821 (0)	Nibble 0822 (0)	Nibble 0823 (1)	Nibble 0824-0825 (2-4)		SDI Addr 103 Loop 8, 2.2 KΩ	SDI Addr 106 Loop 8, 2.2 KΩ	SDI Addr 50 Transmitter 24	SDI Addr 51 Transmitter 24	
D6412 Only	25	Nibble 0826 (0)	Nibble 0827 (0)	Nibble 0828 (1)	Nibble 0829-0830 (2-5)		SDI Addr 104 Loop 1, 2.2 kΩ	SDI Addr 107 Loop 1, 3.65 kΩ	SDI Addr 50 Transmitter 25	SDI Addr 51 Transmitter 25
	26	Nibble 0831 (0)	Nibble 0832 (0)	Nibble 0833 (1)	Nibble 0834-0835 (2-6)		SDI Addr 104 Loop 2, 2.2 kΩ?	SDI Addr 107 Loop 2, 3.65 kΩ	SDI Addr 50 Transmitter 26	SDI Addr 51 Transmitter 26
	27	Nibble 0836 (0)	Nibble 0837 (0)	Nibble 0838 (1)	Nibble 0839-0840 (2-7)		SDI Addr 104 Loop 3, 2.2 KΩ	SDI Addr 107 Loop 3, 3.65 KΩ	SDI Addr 50 Transmitter 27	SDI Addr 51 Transmitter 27
	28	Nibble 0841 (0)	Nibble 0842 (0)	Nibble 0843 (1)	Nibble 0844-0845 (2-8)		SDI Addr 104 Loop 4, 2.2 KΩ	SDI Addr 107 Loop 4, 3.65 KΩ	SDI Addr 50 Transmitter 28	SDI Addr 51 Transmitter 28
	29	Nibble 0846 (0)	Nibble 0847 (0)	Nibble 0848 (1)	Nibble 0849-0850 (2-9)		SDI Addr 104 Loop 5, 2.2 KΩ	SDI Addr 107 Loop 5, 3.65 KΩ	SDI Addr 50 Transmitter 29	SDI Addr 51 Transmitter 29
	30	Nibble 0851 (0)	Nibble 0852 (0)	Nibble 0853 (1)	Nibble 0851-0852 (3-0)		SDI Addr 104 Loop 6, 2.2 KΩ	SDI Addr 107 Loop 6, 3.65 KΩ	SDI Addr 50 Transmitter 30	SDI Addr 51 Transmitter 30
	31	Nibble 0856 (0)	Nibble 0857 (0)	Nibble 0858 (1)	Nibble 0859-0860 (3-1)		SDI Addr 104 Loop 7, 2.2 KΩ	SDI Addr 107 Loop 7, 3.65 KΩ	SDI Addr 50 Transmitter 31	SDI Addr 51 Transmitter 31
	32	Nibble 0861 (0)	Nibble 0862 (0)	Nibble 0863 (1)	Nibble 0864-0865 (3-2)		SDI Addr 104 Loop 8, 2.2 KΩ	SDI Addr 107 Loop 8, 3.65 KΩ	SDI Addr 50 Transmitter 32	SDI Addr 51 Transmitter 32
	33	Nibble 0866 (0)	Nibble 0867 (0)	Nibble 0868 (1)	Nibble 0869-0870 (3-3)		SDI Addr 105 Loop 1, 2.2 KΩ	SDI Addr 107 Loop 1, 2.2 KΩ	SDI Addr 50 Transmitter 33	SDI Addr 51 Transmitter 33
	34	Nibble 0871 (0)	Nibble 0872 (0)	Nibble 0873 (1)	Nibble 0874-0875 (3-4)		SDI Addr 105 Loop 2, 2.2 KΩ	SDI Addr 107 Loop 2, 2.2 KΩ	SDI Addr 50 Transmitter 34	SDI Addr 51 Transmitter 34
	35	Nibble 0876 (0)	Nibble 0877 (0)	Nibble 0878 (1)	Nibble 0879-0880 (3-5)		SDI Addr 105 Loop 3, 2.2 KΩ	SDI Addr 107 Loop 3, 2.2 KΩ	SDI Addr 50 Transmitter 35	SDI Addr 51 Transmitter 35
	36	Nibble 0881 (0)	Nibble 0882 (0)	Nibble 0883 (1)	Nibble 0884-0885 (3-6)		SDI Addr 105 Loop 4, 2.2 KΩ	SDI Addr 107 Loop 4, 2.2 KΩ	SDI Addr 50 Transmitter 36	SDI Addr 51 Transmitter 36
	37	Nibble 0886 (0)	Nibble 0887 (0)	Nibble 0888 (1)	Nibble 0889-0890 (3-7)		SDI Addr 105 Loop 5, 2.2 KΩ	SDI Addr 107 Loop 5, 2.2 kΩ	SDI Addr 50 Transmitter 37	SDI Addr 51 Transmitter 37
	38	Nibble 0891 (0)	Nibble 0892 (0)	Nibble 0893 (1)	Nibble 0894-0895 (3-8)		SDI Addr 105 Loop 6, 2.2 KΩ	SDI Addr 107 Loop 6, 2.2 KΩ	SDI Addr 50 Transmitter 38	SDI Addr 51 Transmitter 38
	39	Nibble 0896 (0)	Nibble 0897 (0)	Nibble 0898 (1)	Nibble 0899-0900 (3-9)		SDI Addr 105 Loop 7, 2.2 KΩ	SDI Addr 107 Loop 7, 2.2 kΩ	SDI Addr 50 Transmitter 39	SDI Addr 51 Transmitter 39
	40	Nibble 0901 (0)	Nibble 0902 (0)	Nibble 0903 (1)	Nibble 0904-0905 (0)		SDI Addr 105 Loop 8, 2.2 KΩ	SDI Addr 107 Loop 8, 2.2 kΩ	SDI Addr 50 Transmitter 40	SDI Addr 51 Transmitter 40

Table 7 (cont'd): Point Expansion Mapping



## 8.2 DX2010 Point Expander Module

### 8.2.1 DX2010 Overview

You can connect up to five DX2010 Point Expander Modules to the D6412 (three to the D4412). In the single point configuration, each DX2010 adds eight points to the system. In the doubled point configuration, each DX2010 adds 16 points to the system. *Table 7* shows how the DX2010 Point Expander sensor loops are assigned to point locations.

- **Current Draw without Aux Output Terminals:** 35 mA Standby
- **Current Draw with Aux Output Terminals:** 135 mA maximum with connected accessories

Review the *Section 5.0 Power Outputs* to be sure you provide enough power for the Point Expander Modules and any other powered devices you connect to the panel.

Refer to the *DX2010 Installation Guide* (P/N: 46413) for complete installation, addressing and operating instructions.

### 8.2.2 DX2010 Installation



*Failure to follow the mounting instructions in this guide may result in damage to the module.*

The DX2010 contains static-sensitive components and must be handled with care. Follow antistatic procedures when handling the modules.

The DX2010 Module can be mounted in a D203 Enclosure. Mount the module in the enclosure as shown in *Figure 13*.

You can also install the DX2010 board in the control panel's enclosure. The D2203 enclosure can hold up to five DX2010 modules (see *Figures 14 and 15*).

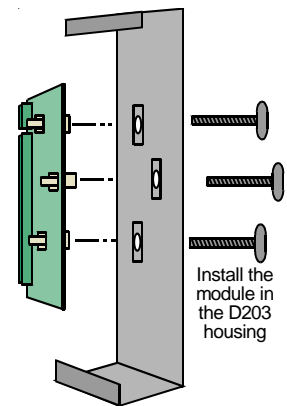

**Figure 13: Installing the DX2010 in D203 Enclosure**

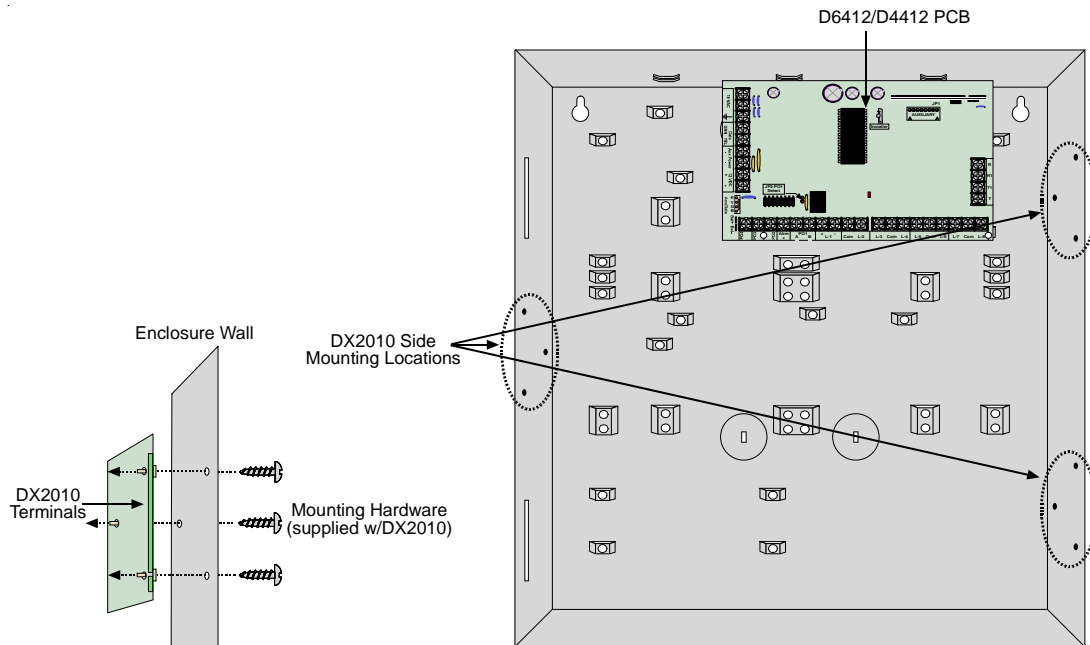
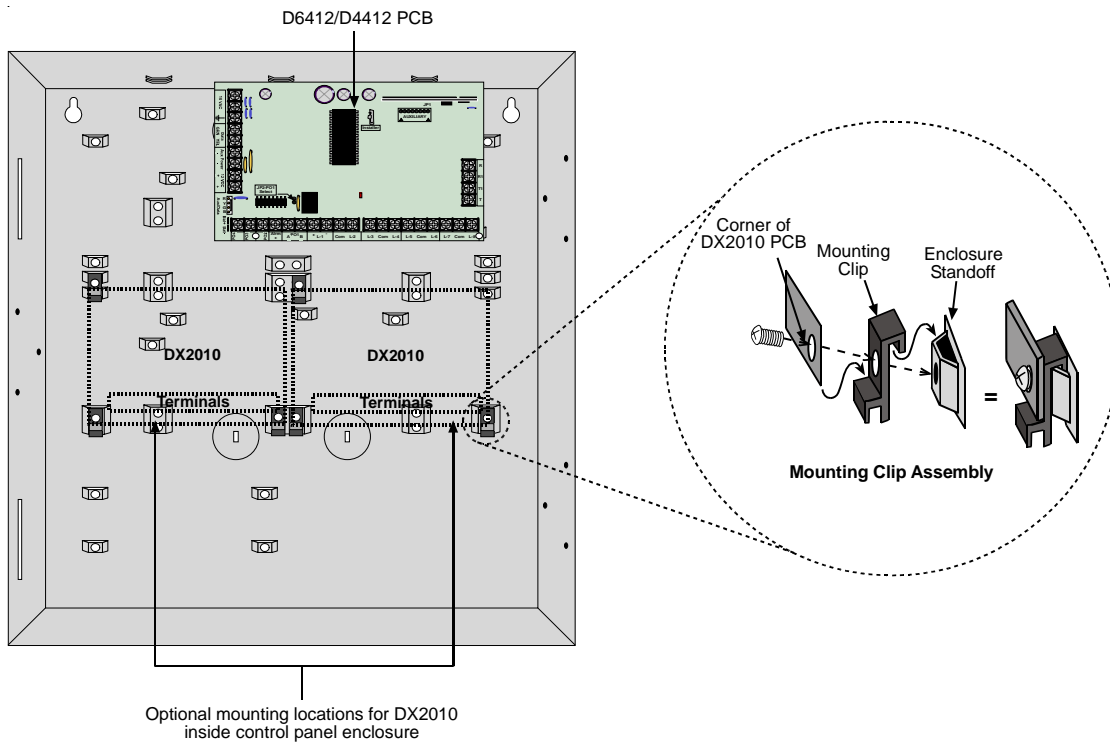

**Figure 14: Installing the DX2010 in the Panel Enclosure**

# D6412/D4412

## Off-Board Sensor Loops

The DX2010 can also be mounted to the back wall of the control panel enclosure. See *Figure 15*.



**Figure 15: Optional Enclosure Mounting Locations for the DX2010**

### 8.2.3 DX2010 to Panel SDI Bus Connections

Connect the panel's Data and Aux Power terminals to the DX2010 Module as shown in *Figure 16*. Refer to *Table 8* for the SDI bus wiring length requirements.

	22 AWG (0.8 mm)	18 AWG (1.2 mm)
Panel to DX2010 DX2010 AUX Output NOT Used	305 m (1000 ft.)*	610 m (2000 ft.)*
Panel to DX2010 DX2010 AUX supplying 100 mA	30 m (100 ft.)**	76 m (250 ft.)**
* Wire length may be restricted by panel limitations. See the Installation Guide for more information.		
** If the DX2010 is powered directly by an external auxiliary power supply (Figure 18), use the wire lengths specified in the first row.		

**Table 8: DX2010 Wire Lengths**

The wire lengths shown in *Table 8* must be shared by all devices connected to the terminals.



**Do not use twisted pair or shielded cable. Do not share cable with the keypad lines. The maximum distance may be limited to 76 m (250 ft.) if the Aux Output is used. See Section 8.2.4 DX2010 Auxiliary Output Connections.**

Off-Board Sensors Loops

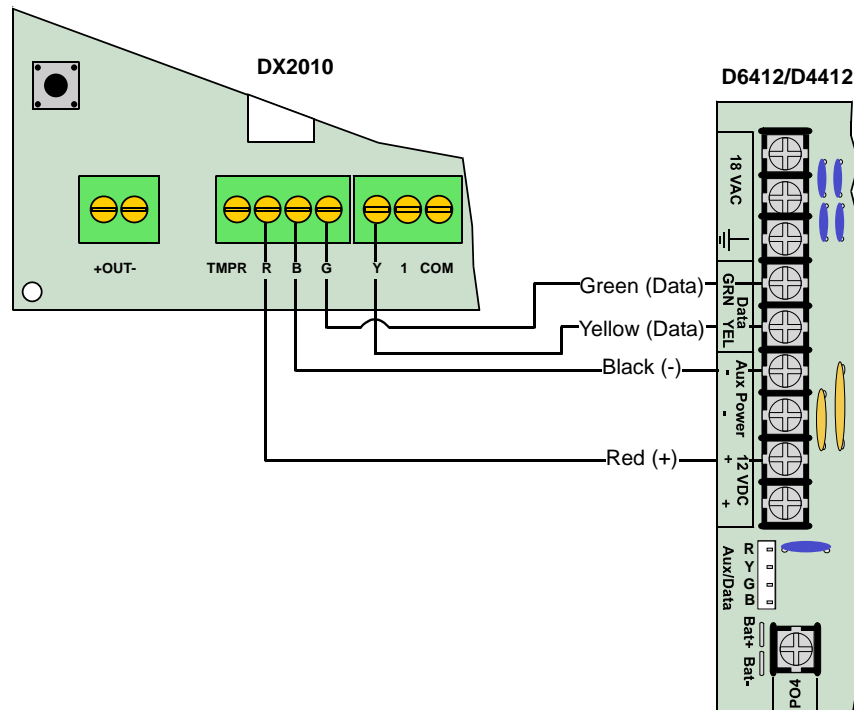

Figure 16: Wiring the DX2010 to the D6412/D4412

If you need to power the DX2010 with an external 12 VDC power supply, wire it as shown in *Figure 17*. See *Section 4.3 External Power Supply* for external power supply restrictions.

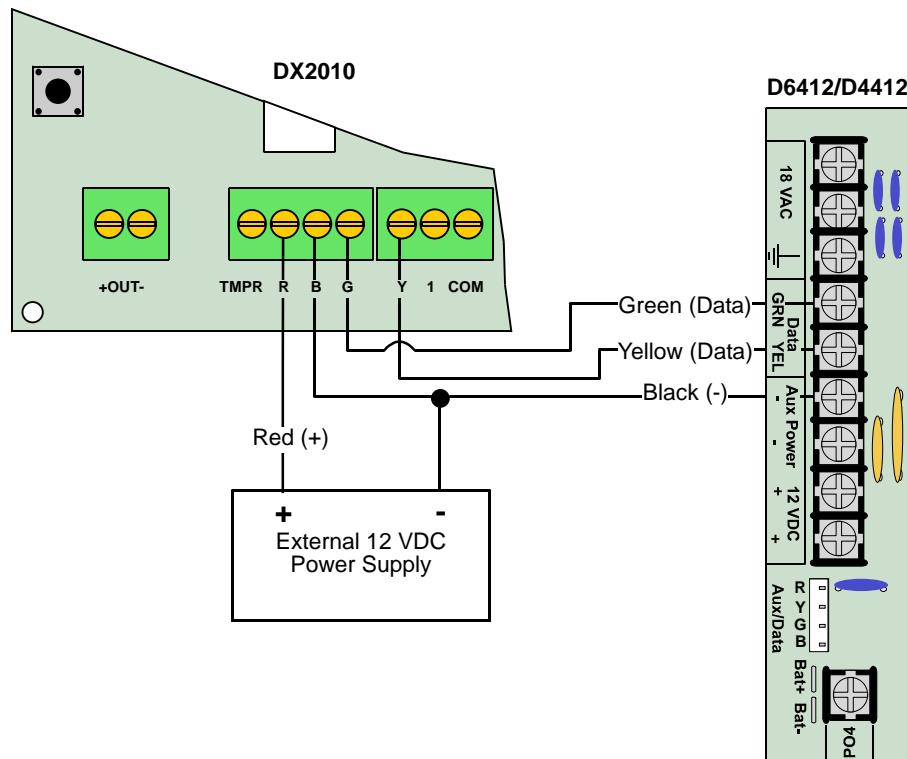



Figure 17: Wiring the DX2010 for External Power Supply

## Off-Board Sensors Loops

### 8.2.4 DX2010 Auxiliary Output Connections

The DX2010 has the capacity to provide 12 VDC at up to 100 mA from the Auxiliary Output (-) OUT (+) terminals to power external devices such as motion detectors. See *Figure 18*.

**IMPORTANT**  When using the DX2010's auxiliary output, the maximum distance between the D6412/D4412 and the DX2010 must be limited to 76 m (250 ft.) when using #18 AWG (1.2 mm) wire, or 30 m (100 ft.) when using #22 AWG (0.8 mm) wire. The maximum distance from the DX2010 Output terminals and the remotely powered devices (PIRs, smoke detectors, etc.) must be limited to 15 m (50 ft.) for #22 AWG (0.8 mm) or 30 m (100 ft.) for #18 AWG (1.2 mm) wire.

**IMPORTANT**  If the DX2010's Aux Output ("+Out-" terminals) is used as an auxiliary power source, the DX2010's "R" and "B" wires must be home-run to either the panel or to an auxiliary power supply. Do not use a daisy-chain wire configuration. See *Figure 18*.

If the DX2010 module is powered by an external 12 VDC power supply, the output terminals can supply power for up to 138 m (450 ft.) from the DX2010 to the remotely powered devices.

### 8.2.5 DX2010 Tamper Input Connections

Each DX2010 Module provides an input for tamper devices. The tamper input is in addition to the point sensor loops. Supervising an enclosure tamper does not consume a point. A fault on the tamper input is reported as a tamper event for the SDI address the DX2010 is set to.

The tamper output may monitor external Normally Closed (N/C) tamper switches when wired as shown in *Figure 19*. The tamper circuit must be closed to provide proper DX2010 tamper supervision to the control panel. **Do not use an EOL resistor.**

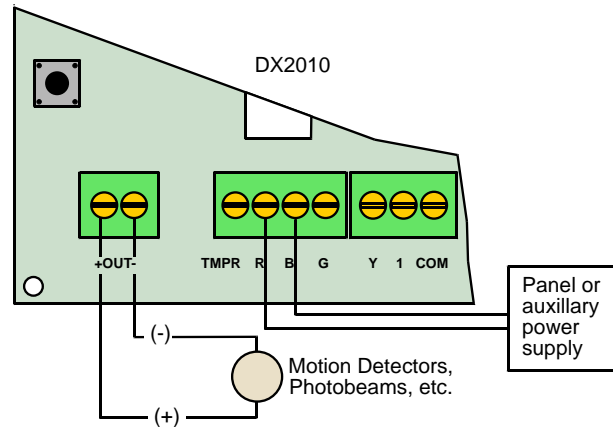

Figure 18: Auxiliary Output Connections

The DX2010 also provides an on-board tamper switch for use if the DX2010 is installed inside the AE20 plastic enclosure. The cover tamper spring is supplied with the DX2010. The on-board tamper switch cannot be used if the DX2010 is mounted inside the panel's enclosure (wire the tamper input as shown in *Figure 19* if installed in the control panel's enclosure).

If neither the tamper input or the on-board tamper switch is used, a wire jumper must be placed as shown in *Figure 19*.

Use either the tamper input or the on-board tamper switch. Both cannot be used simultaneously.

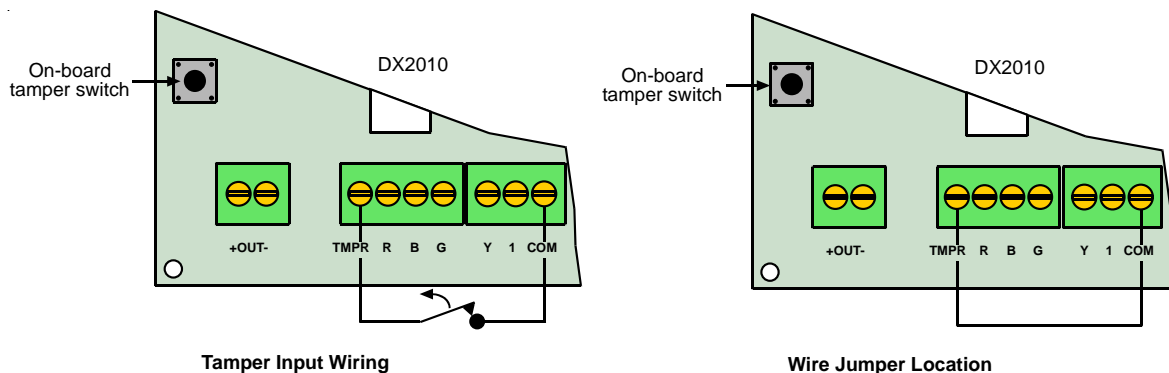

Figure 19: DX2010 Tamper Input Wiring

### 8.2.6 DX2010 Sensor Loop (Point) Connections

The DX2010 supports both Normally Open and Normally Closed contacts in the standard sensor loop configuration. It supports Normally Closed contacts in the doubled sensor loop configuration.

The DX2010 is not designed for use with two-wire smoke detectors.

8.2.6.1 DX2010 Standard Sensor Loop Wiring

The single loop configuration for DX2010 standard sensor loop wiring is shown in *Figure 20*.

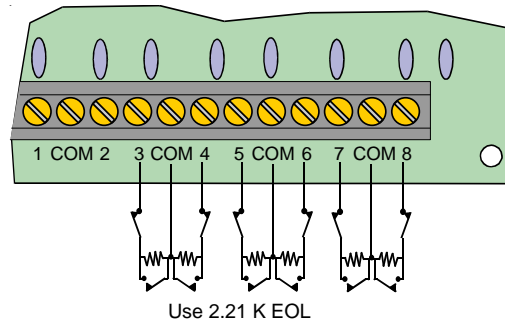

Figure 20: DX2010 Sensor Loop Wiring, Single Loop Configuration

8.2.6.2 DX2010 Doubled Sensor Loop (Point) Wiring

The doubled loop configuration for DX2010 sensor loop wiring is shown in *Figure 21*.

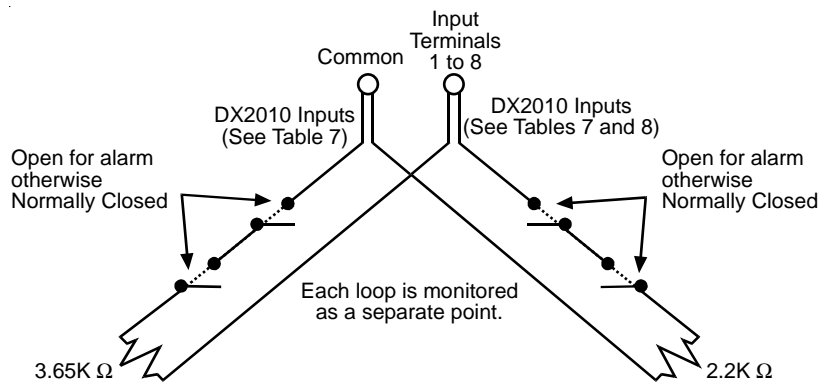

Figure 21: DX2010 Sensor Loop Wiring, Doubled Loop Configuration

Tables 9 and Table 10 identify the 106 and 107 DX2010 sensor loop addresses, respectively.

DX2010 Sensor Loop								
EOL	1	2	3	4	5	6	7	8
3.65 K	9	10	11	12	13	14	15	16
2.2 K	17	18	19	20	21	22	23	24

Table 9: DX2010 Address 106

DX2010 Sensor Loop								
EOL	1	2	3	4	5	6	7	8
3.65 K	25	26	27	28	29	30	31	32
2.2 K	33	34	35	36	37	38	39	40

Table 10: DX2010 Address 107 (for D6412 only)

8.2.7 DX2010 Address Programming

Each DX2010 module connected to the panel must have its address jumpers set to the addresses. These address settings are listed in *Table 11*.

## Off-Board Sensors Loops

Panel	Location #	For Standard Sensor Loop: Set Location's Device Parameter to 2. Set DX2010 Address as shown below.	For Doubled Sensor Loop: Set Location's Device Parameter to 2. Set DX2010 Address as shown below.
D6412/D4412	1 to 8	SDI Address 101	
D6412/D4412	9 to 16	SDI Address 102	SDI Address 106
D6412/D4412	17 to 24	SDI Address 103	SDI Address 106
D6412 only	25 to 32	SDI Address 104	SDI Address 107
D4412 only	33 to 40	SDI Address 105	SDI Address 107

**Table 11: DX2010 Address Settings**

**For example:** You want to use a DX2010 sensor loop for panel Point Location 9 (see *Locations* in the *D6412/D4412 Program Entry Guide* [P/N: 45351] for a detailed description of locations and their relationship to points). You must connect a DX2010 and set its address DIP switches to 102. Any time the address DIP switches are changed, you must cycle the power to the module **OFF** and then **ON** for the changes to take effect.

Set the address DIP switches as shown in the *Table 10*. The proper DX2010 DIP switch configuration are shown in *Figure 22*.

DIP Switches	DIP Switch Settings					
	S1	S2	S3	S4	S5	S6
<b>Module Address</b>	<b>32</b>	<b>16</b>	<b>8</b>	<b>4</b>	<b>2</b>	<b>1</b>
101	OFF	OFF	OFF	OFF	OFF	OFF
102	OFF	OFF	OFF	OFF	OFF	ON
103	OFF	OFF	OFF	OFF	ON	OFF
104	OFF	OFF	OFF	OFF	ON	ON
105	OFF	OFF	OFF	ON	OFF	OFF
106	OFF	OFF	OFF	ON	OFF	ON
107	OFF	OFF	OFF	ON	ON	OFF

**Table 12: DX2010 Address Jumper Settings**



**Figure 22: DX2010 DIP Switch Configuration**

### 8.2.8 DX2010 Status LED

- One flash per second indicates normal operation.
- LED steady ON can indicate any of the following:
  - G wire is not connected or there is a communications problem between the control panel and the DX2010.
  - No locations (points) are assigned to the DX2010 with this address. See the *Locations* section in the *D6412/D4412 Program Entry Guide* (P/N: 45351).
  - Address on the DX2010 is not set correctly.
- LED OFF indicates that there is no power to the module.

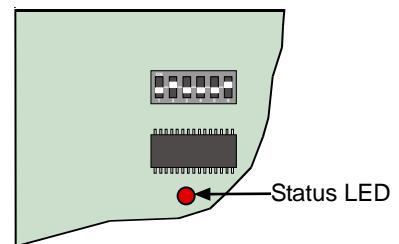

**Figure 23: DX2010 Status LED**

## 9.0 On-Board Outputs

The panel supports up to four on-board programmable outputs (PO1 to PO4).

PO2 can be configured as a supervised siren driver. Refer to *Global Output Configuration* in the *D6412/D4412 Program Entry Guide* (P/N: 45351) for programming instructions. When programmed as a siren driver, PO2 draws power from the Alarm + terminal. When connected to a 4 Ω horn/speaker, PO2 draws 380 mA of power. When connected to an 8 Ω horn/speaker, it draws 330 mA of power. Use the appropriate current draw in your total alarm power calculation.

- **PO1:** PO1 terminals can be configured as an alarm power output. JP2-PO1 Jumper must be closed. The default configuration for PO1 makes it a dry contact, Normally Open relay with PO1 Jumper open (see *Figure 24*).

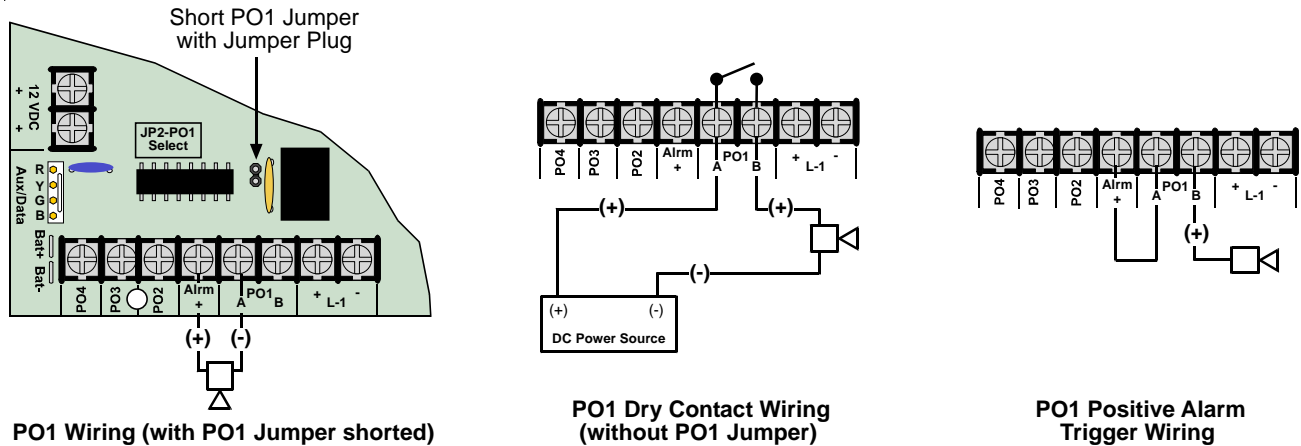

Figure 24: PO1 Wiring

- **PO2:** Output PO2 can be used with Alarm+ as a supervised siren driver. Connect an approved 4 or 8 Ω siren. Alternatively, PO2 can sink up to 500 mA 12 VDC. For larger loads, use a Bosch Security Systems D133 Relay Module or a Bosch Security Systems D134 Dual Relay Module.
- **PO3 and PO4:** Outputs PO3 and PO4 can be configured for Alarm Output. These outputs can sink up to 500 mA 12 VDC each. For larger loads, use a Bosch Security Systems D133 Relay Module or a Bosch Security Systems D134 Dual Relay Module (see *Figure 25*).

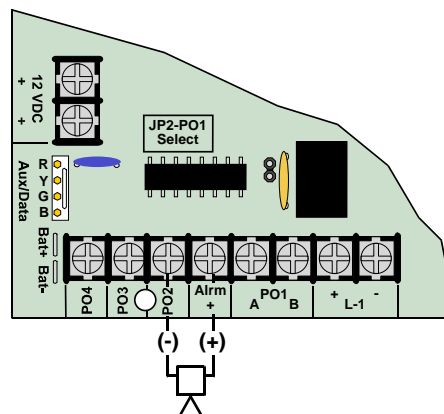

Figure 25: PO2-PO4 Wiring



**Use the Fire System Power Formula (see Section 5.4.1 Available Power) to calculate the current available for fire and combined fire/burglary systems.**

## On-Board Outputs

**Unexpected Output at PO1 to PO4:** If these outputs do not provide the alarm output you expect:

- Check the programming for Programmable Outputs in the *Outputs* section of the *D6412/D4412 Program Entry Guide* (P/N: 45351).
- Check the Point Index Configuration section of the *D6412/D4412 Program Entry Guide* to verify the points you are activating are programmed for alarm output.



*If Programmable Output 2 is configured as a supervised siren driver (in combination with the Alrm + terminal), you must connect a 4  $\Omega$  or 8  $\Omega$  siren/speaker to PO 2 to clear the siren/speaker supervision trouble.*



## 10.0 Off-Board Outputs

### 10.1 Overview

You can expand the total number of programmable outputs to twenty for the D6412 (twelve for the D4412) using the DX3010 Octo-Output Module (two required for twenty outputs) or DX3020 Module. Instructions for the DX3010 Module are included in this guide (as well as with the module). The DX3020 Module emulates two DX3010 Modules with the D6412 (emulates one with the D4412). DX3020 specific instructions are included with the module.

### 10.2 DX3010 Octo-Output Module

#### 10.2.1 Overview

The DX3010 Octo-Output Module allows you to add outputs to your system in groups of eight. You can add up to two DX3010 Octo-Output Modules to the D6412 (one to the D4412). Combining the four on-board programmable outputs with two DX3010 Octo-Output Modules (one on the D4412) makes a total of twenty programmable outputs available for the D6412 (12 for the D4412). Review *Section 5.0 Power Outputs* to be sure you provide enough power for the Octo-Output Modules and any other powered devices you connect to the panel.

You can assign any of the programmable output functions to the Octo-Output Module's individual outputs separately. See *Outputs* in the *D6412/D4412 Program Entry Guide* (P/N: 45351) for programming details.



*The DX3010 relay outputs are not supervised and cannot be used in fire or combined fire/burglary installations for primary indicating devices.*

**Current Draw:** 10 mA Standby plus 40 mA for each energized output (relay) for a total of 330 mA maximum with all eight outputs energized.

Refer to the *DX3010 Installation Guide* (P/N: 46925) for complete installation, addressing, and operating instructions.

#### 10.2.2 Configuring the DX3010 Octo-Output Module



*Outputs may activate when setting the DX3010's switches, programming the panel, resetting the panel or applying power to the panel. You may want to disconnect equipment connected to outputs while performing these functions.*

#### 10.2.3 Relay Outputs

Each DX3010 output provides a Form "C" dry contact rated for 5.0 A at 28 VDC. Normally-open, common, and normally-closed terminals are available for each relay output. When an individual output is activated, there is continuity between the normally-open and common terminals. When the output is not activated, there is continuity between the normally-closed and common terminals.

# D6412/D4412

## Off-Board Outputs

### 10.2.4 Installation

You can install the DX3010 in the enclosure with the panel (see *Figure 26*) using the mounting hardware supplied with the DX3010.

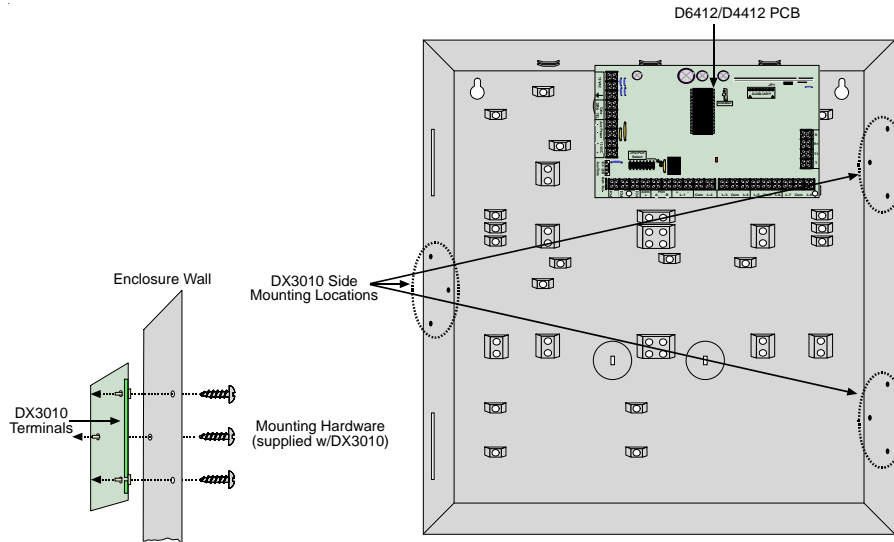

**Figure 26: DX3010 - Control Panel Enclosure Side Mounting**

Alternatively, you can mount the DX3010 remotely in its own D203 enclosure as shown in *Figure 27*.

Distance from the panel is determined by the total combined wire length of all devices (including keypads) connected to the panels data terminals. The combined total wire length must not exceed 305 m (1000 ft.) 22 AWG (0.8 mm).

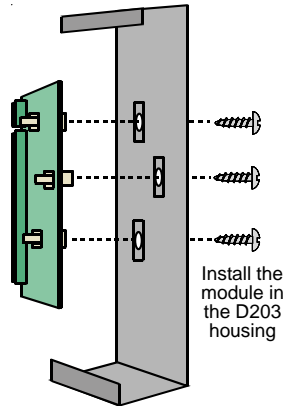

**Figure 27: Installing the DX3010 in a Remote Enclosure**

### 10.2.5 DX3010 to D6412/D4412 SDI Bus Wiring Connections

*Table 13* identifies the SDI bus wiring length requirements.

**IMPORTANT** *If the DX3010 is to be installed far from the control panel, then the control panel cannot be used to power the DX3010. An external power supply must be used. See *Figure 29* for external power supply connections.*

	Power Source	#22 AWG (0.8 mm)	#18 AWG (1.2 mm)
D6412/D4412 to DX3010	D6412/D4412	12.2 m (40 ft.)	24.2 m (80 ft.)
D6412/D4412 to DX3010	External Power Supply	305 m (1000 ft.)	610 m (2000 ft.)
External Power Supply to DX3010		12.2 m (40 ft.)	24.4 m (80 ft.)

**Table 13: DX3010 Wire Lengths**

Power down the panel to connect the DX3010 as shown in *Figure 28*.

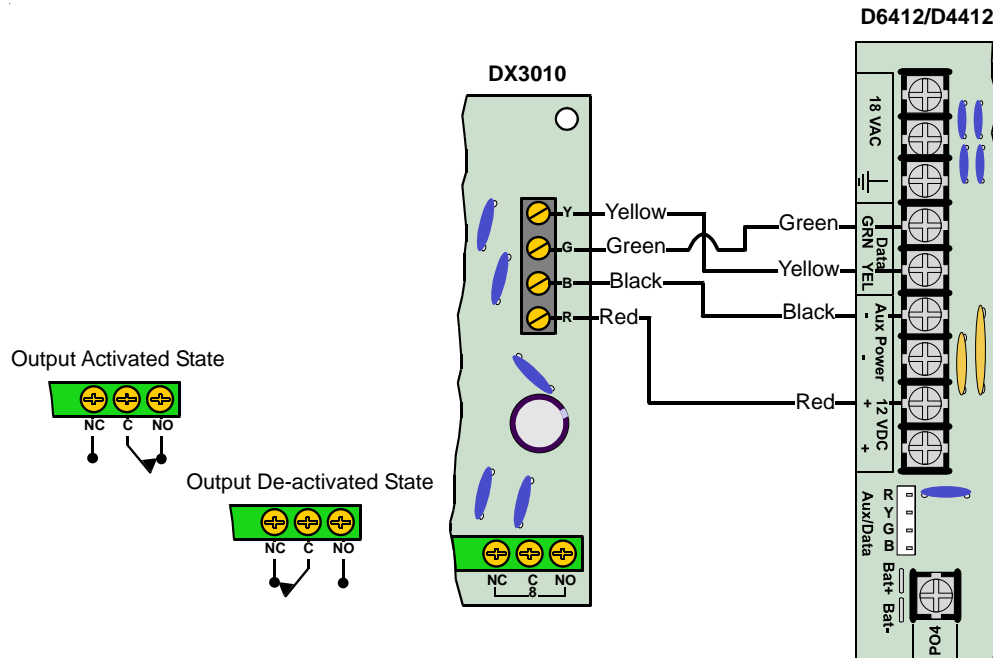

Figure 28: Wiring the DX3010 to the D6412/D4412

If necessary to power the DX3010 from an external power source, connect it to the power source and the panel as shown in *Figure 29*. See *Section 4.3 External Power Supply* for external power supply restrictions.

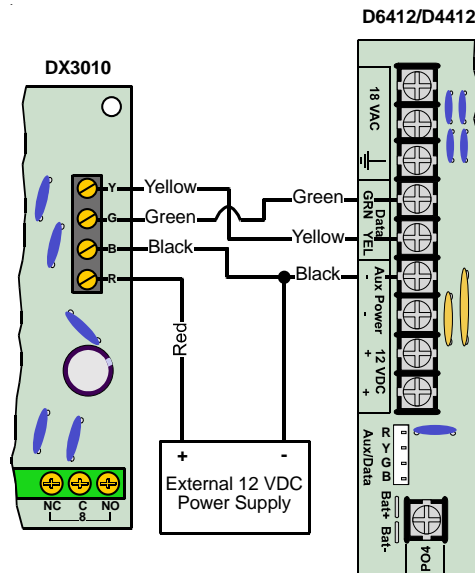

Figure 29: Wiring for External Power Supply

# D6412/D4412

## Off-Board Outputs

### 10.2.6 Address Programming

Each DX3010 Module connected to the panel must have its address jumpers set to the address shown in *Table 14*.

Panel	Output #	SDI Address
D6412/D4412	5 to 12	SDI Address 150
D6412 only	13 to 20	SDI Address 151

Table 14: DX3010 Address Settings

Any time the address jumpers are changed, you must cycle the control panel power OFF and then ON for the changes to take effect. Set the address jumpers as shown in the *Table 15*. "DN" indicates that the DIP switch is CLOSED (Down). See *Figure 30* for DIP Switch configuration.

Panel	SDI Address	DIP Switch, X = DIP Switch is CLOSED					
		1	2	4	8	16	Mode
D6412/D4412	150	UP	UP	UP	UP	UP	DN
D6412 only	13 to 20	DN	UP	UP	UP	UP	DN

Table 15: DX3010 Address Jumper Settings

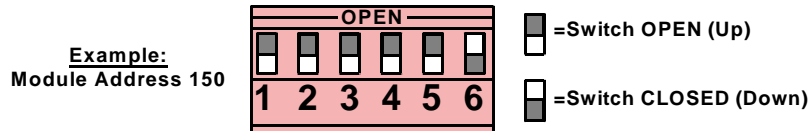

Figure 30: DX3010 Address DIP Switches

## 11.0 Arming Devices

### 11.1 Description

Command centers, maintained or momentary contact keyswitches, Premises RF arming devices, or any of these devices in combination are used to arm and disarm areas. The D6412 may contain up to four areas (up to two areas on the D4412) that can be armed and disarmed individually.

### 11.2 Command Centers

A Bosch Security Systems command center is a four-wire SDI device used to arm and disarm areas, announce complete system status, initiate system tests, and control many functions of the security system.

The panel can supervise up to eight wired command centers and 4 RF Keypads. The panel transmits a Serial Device Trouble Report, SDI MISSING in the Modem IIIa<sup>2</sup> format or SYS PERIPHERAL TROUBLE in the CONTACT ID format, if it loses communication with a wired supervised command center. RF Keypads are shown as missing by SDI address. See *RF Keypads* in the *D6412/D4412 Program Entry Guide* (P/N: 45351).

SYSTEM FAULT appears in any command center with text display capability that loses communication with the panel. A system trouble appears at all other command centers connected to the system. SYSTEM FAULT also appears for approximately 10 sec. during power up.

See *Command Center* in the *D6412/D4412 Program Entry Guide* (P/N: 45351) for complete programming and operation details for command centers.

#### 11.2.1 Assigning the Command Center an Address

On-board DIP switches are used to assign a unique address to the command center. Command centers 1 to 8 are assigned to SDI address 1 to 8. See *Command Centers* in the *D6412/D4412 Program Entry Guide* (P/N: 45351) for a complete description of command center programming (area assignment, etc.).

Table 14 shows the correct address setting for each command center address. See *Figure 31* for proper command center DIP switch orientation.

SDI Address	Switch Number, X = Switch On					
	1	2	4	8	16	Mode
0*	OFF	OFF	OFF	OFF	OFF	OFF
1	ON	OFF	OFF	OFF	OFF	ON
2	OFF	ON	OFF	OFF	OFF	ON
3	ON	ON	OFF	OFF	OFF	ON
4	OFF	OFF	ON	OFF	OFF	ON
5	ON	OFF	ON	OFF	OFF	ON
6	OFF	ON	ON	OFF	OFF	ON
7	ON	ON	ON	OFF	OFF	ON
8	OFF	OFF	OFF	ON	OFF	ON

Table 16: Command Center Address Assignments DIP Switch Settings

\* Address 0 is reserved for the installer's keypad. This keypad is not intended for permanent installation and should remain on-premises for future programming sessions. See *Section 13.0 Installer's Keypad and Installer's Mode*, for more information.



Figure 31: Command Center DIP Switch Orientation

# D6412/D4412

## Arming Devices

### 11.2.2 Command Center Installation

Consult the command center *Installation Guide* for installation and mounting instructions. Command centers connect to the panel in parallel as shown in *Figure 32*.

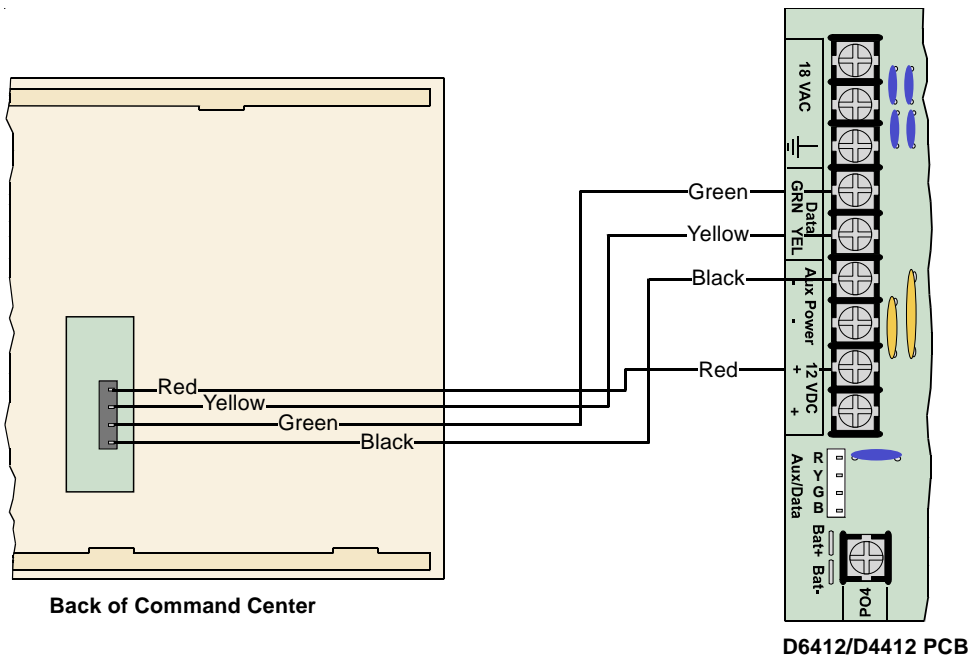

Figure 32: Wiring Command Centers to the D6412/D4412

Refer to *Table 17* for panel SDI Bus to command center wiring length requirements.

	#22 AWG (0.8 mm)	#18 AWG (1.2 mm)
D6421/D4412 to D621/D623	305 m (1000 ft.)	610 m (2000 ft.)
D6412/D4412 to D625*	69 m (225 ft.)	183 m (600 ft.)
D6412/D4412 to D621/D623/D625 using an External Power Supply	505 m (1000 ft.)	610 m (2000 ft.)
* Due to higher current requirements for the D625 Vacuum Fluorescent Command Center, the wire lengths shown in this table must be used when wiring it from the control panel.		

Table 17: Command Center Wire Lengths

If an external power supply is used, follow the lengths as shown in *Table 17*.

Review *Section 5.0 Power Outputs* to determine the total power output requirements for your system. You may need to add one or more External Power Supply Modules for the number of command centers you want to use. *Figure 33* shows an external power supply powering command centers in a stand-alone configuration.



**For UL certificated accounts, use a UL listed power supply.**

IMPORTANT

See *Section 4.3 External Power Supply* for external power supply restrictions.

*Figure 33* shows the common from the External Power Supply Module connected to both the command centers' common and the common on the control panel.

A stand-alone power supply powering any device connected to the panel must also be connected to the Aux - (Aux negative) terminal on the panel.



**Do not connect the stand-alone power supply to earth ground.**

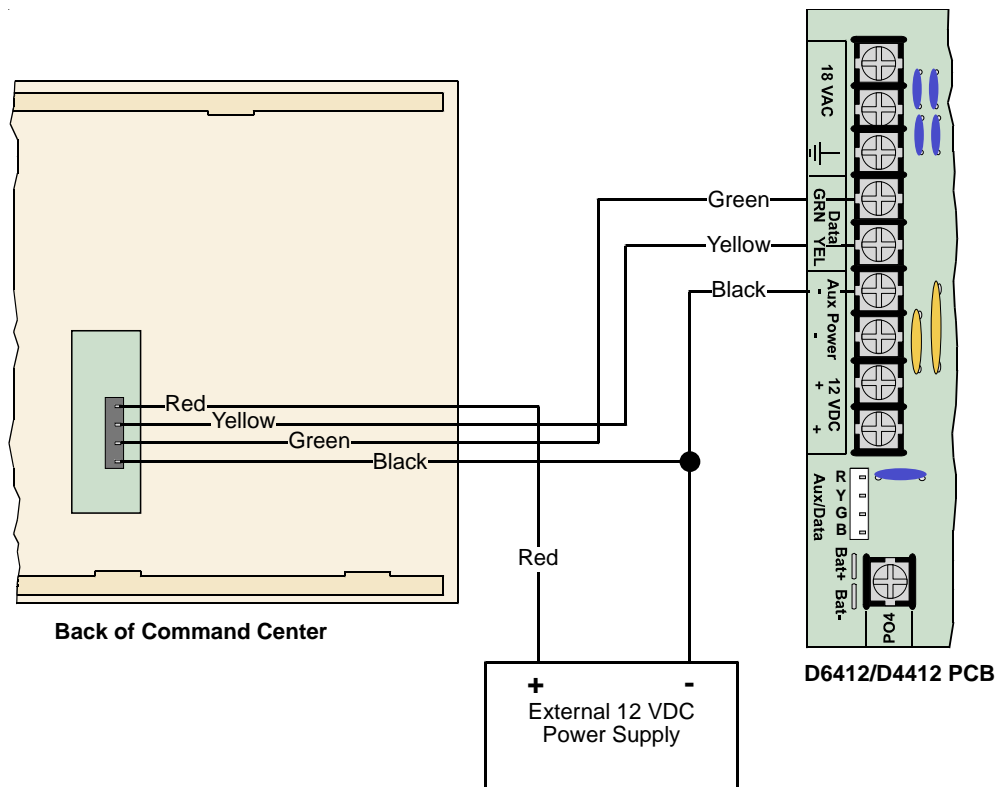

Figure 33: External Power for Command Centers

### 11.3 D268/D269, D279 Independent Zone Control

You can program on-board points 2 to 8 so the D268's, D269's, or D279's (or later versions') Independent Zone Controls (IZC) operate as independent point controls (arms and disarms the point).

See *Point Index Configuration* in the *D6412/D4412 Program Entry Guide* (P/N: 45351) for programming information. See the installation literature that accompanies the D268, D269, and D279 (or later versions) for wiring and operation instructions.



**To use the D268's, D269's, or D279's (or later versions') IZC, you must program the panel's on-board points for 1 k $\Omega$  EOL resistors. Points 2 to 8 must all be supervised with 1 kW EOL resistors, even if an IZC is only used for one point. See Global Point Configuration in the *D6412/D4412 Program Entry Guide* (P/N: 45351) for programming instructions. Only use on-board points 2 to 8 with an IZC. No EOL resistor is used on the points connected to the IZC.**

### 11.4 Keyswitch

#### 11.4.1 Keyswitch Description

You can connect a maintained or momentary contact arming station (UL Listed security device keyswitch) to master arm/disarm any of the areas in the system. The keyswitch is connected to an on-board or off-board point's sensor loop. Outputs can be programmed to activate arming status LEDs for keyswitch arming stations. See the *Outputs* section of the *D6412/D4412 Program Entry Guide* (P/N: 45351) for more information.

#### 11.4.2 Keyswitch Programming

See *Point Index Configuration* in the *D6412/D4412 Program Entry Guide* (P/N: 45351) for point programming for keyswitches.

## Arming Devices

### 11.4.3 Keyswitch Installation

For maintained switches, connect the EOL resistor for the point at the keyswitch so the switch opens the circuit when it operates. A short on the circuit produces an alarm if the area is armed and a trouble if it is disarmed (see *Figure 34*).

For momentary switches, connect the EOL resistor for the point at the keyswitch so the switch shorts the resistor when it operates. If the area is armed, an open on the circuit produces an alarm; and when the area is disarmed, an open on the circuit produces a trouble (see *Figure 34*).

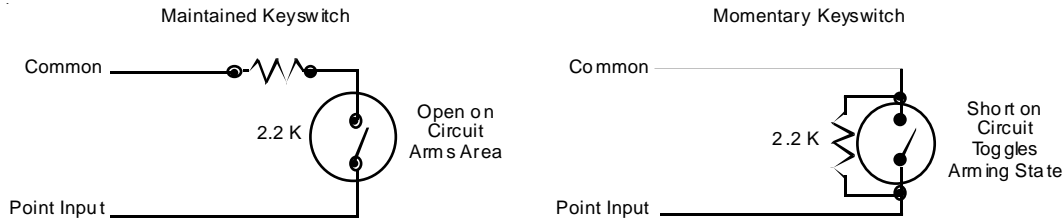

Figure 34: Keyswitches

### 11.4.4 Keyswitch Operation

#### Arming/Disarming

The panel offers a wide variety of keyswitch arming options. See *Point Index Configuration* in the *D6412/D4412 Program Entry Guide* (P/N: 45351) for details on configuring keyswitch arming options.

#### Silencing Alarms

- **Momentary Keyswitch:** To silence alarms (stop Alarm output), operate the keyswitch. If the area is armed, operating the keyswitch to silence the alarm also disarms the area. If the area is disarmed, operating a momentary keyswitch to silence the alarm does not arm the area.
- **Maintained Keyswitch:** If the area is armed, turn the keyswitch to the disarmed position. The panel disarms the area and silences the alarm. If the area is disarmed, turn the keyswitch to the armed position (the panel does not arm) and return to the disarmed position.



## 12.0 SDI Devices

### 12.1 Description

The panel supports a variety of SDI devices, including the command centers, DX2010 Point Expanders, DX3010 Octo-Outputs discussed in previous sections.

### 12.2 Installation

Consult the installation guide for the specific SDI device for complete installation instructions. SDI devices connect to the panel in parallel as shown in *Figure 35*.

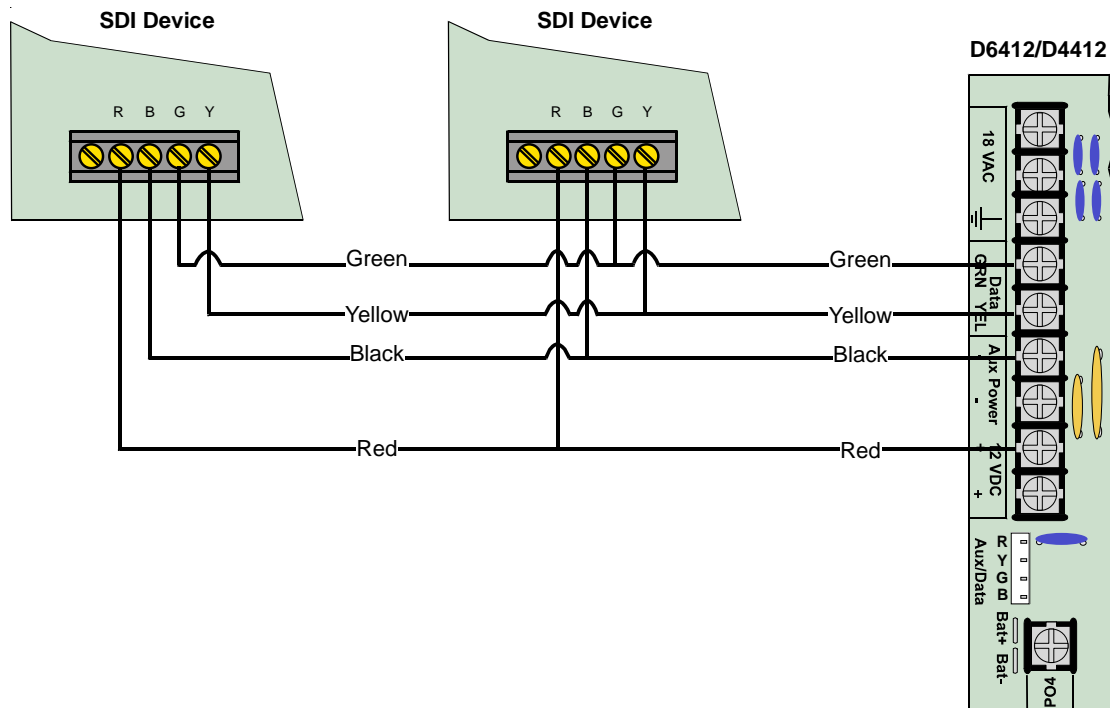

Figure 35: SDI Device Wiring

These devices may share power with the panel or be powered by a stand-alone power source.

Review *Section 5.0 Power Outputs* to determine the total power output requirements for your system. You may need to add one or more External Power Supply Modules for the number of devices you want to use. *Figure 33* shows an external power supply powering command centers.



**For UL certificated accounts, use a UL Listed power supply.**

*Figure 36* shows the common from the External Power Supply Module connected to the command centers' common and the common on the control panel.

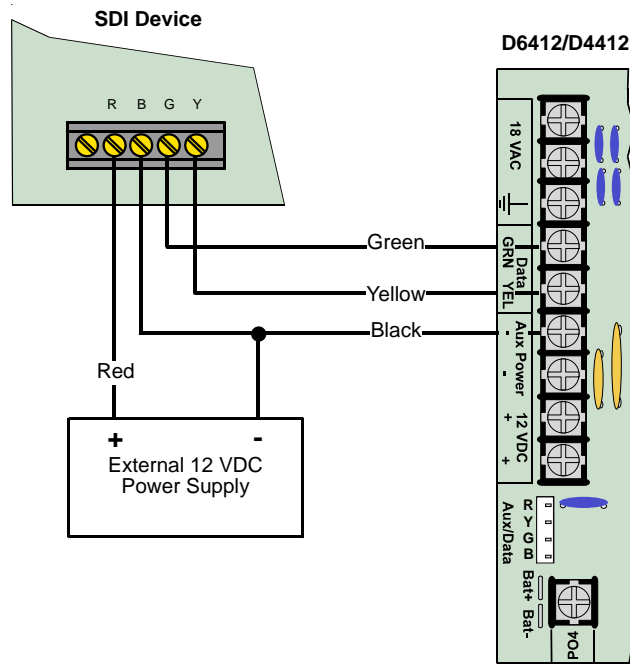

Figure 36: External Power for SDI Devices

### 12.3 DX4010 RS-232 Serial Interface Module

Bosch Security Systems' DX4010 RS-232 Serial Interface Module can be used to connect a standard serial printer, or other serial devices, to the panel. It can also be used for a RAM IV remote programming direct connection. Refer to the *DX4010 Installation Guide* (P/N: 48210) for complete installation, addressing, and operating instructions.

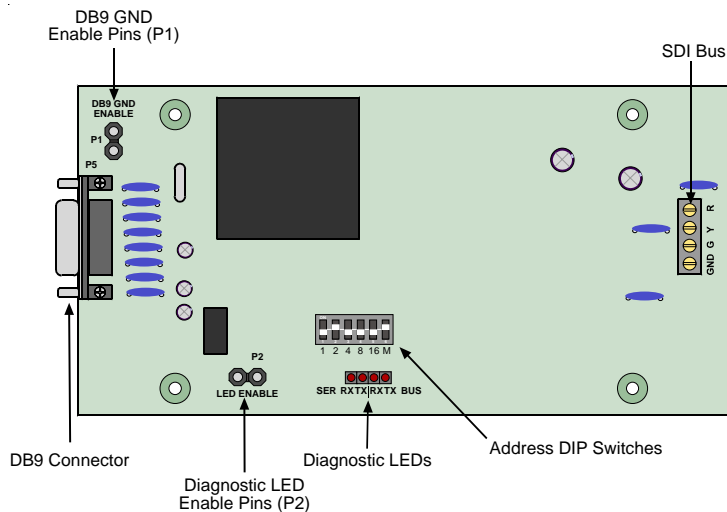

Figure 37: DX4010 RS-232 Serial Interface Module

#### 12.3.1 DX4010 Installation

The intended installation location for the DX4010 is in the plastic enclosure that it is shipped in. This is a low-profile, aesthetically appealing housing that can be placed on a desktop or similar surface.

Distance from the panel is determined by the total combined wire length of all devices (including keypads) connected to the panel's data terminals. The combined total wire length must not exceed 305 m (1000 ft.) for #22 AWG (0.8 mm), or 610 m (2000 ft.) for #18 AWG (1.2 mm).

### 12.3.2 DX4010 to D6412/D4412 SDI Bus Wiring Connections

See *Figure 38* for acceptable power wiring connections. See *Section 4.3* for external power supply restrictions.

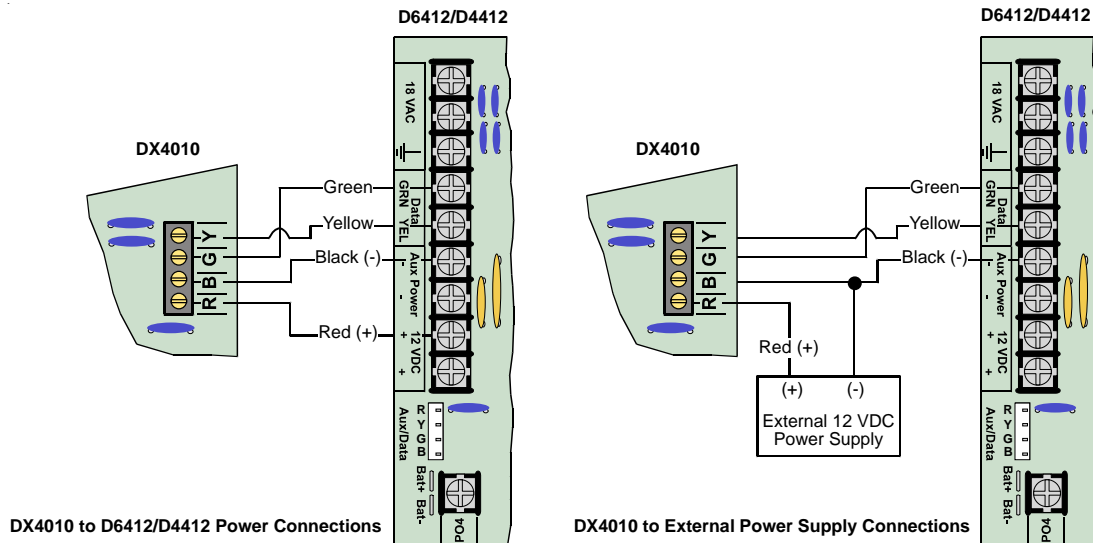

Figure 38: DX4010 Power Connections

### 12.3.3 RAM IV Direct Connection

The DX4010 can be used to connect directly to the panel for RAM IV remote programming. It also lets the user perform diagnostic and history retrievals in RAM IV.

To connect directly to the panel for a RAM IV session:

1. Make sure the DX4010's Address DIP Switches are set to Address 0. See the *DX4010 Installation Guide* (P/N: 49539) for address DIP Switch location and positioning.
2. Using a null modem cable (not included), connect the DX4010 to COM port 1 or 2 (or an available COM port) on your computer. The DX4010 has a DB-9 male serial connector. If this does not fit your computer, you need an adapter.
3. Wire the flying leads of the colored cable connector (included with panel) to the DX4010's SDI Bus terminals. Plug the connector end onto the D6412/D4412. See *Figure 39* for details.
4. Plug the connector end of the cable onto the panel PCB. See *Figure 40* for details.

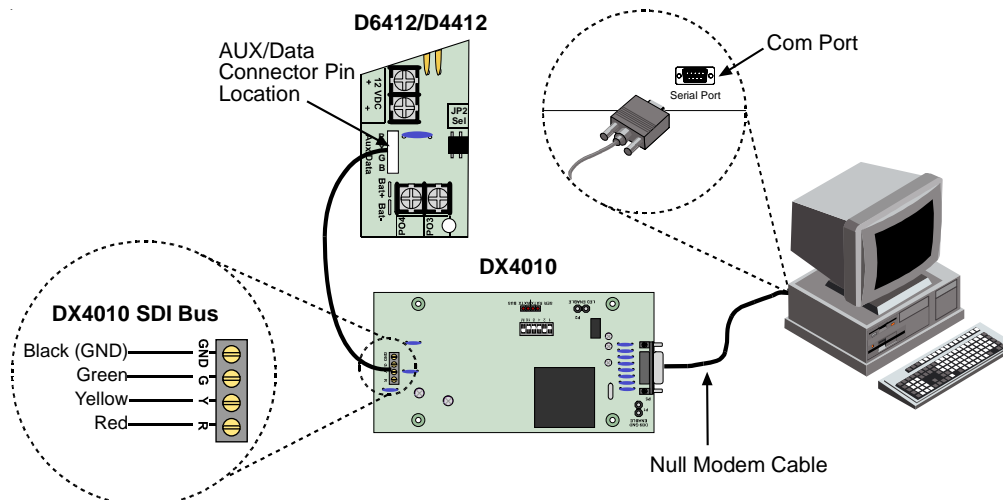

Figure 39: Creating a RAM IV Direct Connection

## SDI Devices

### 12.3.4 Configuration Jumpers

#### P2 – Diagnostic LED Pins

The diagnostic LEDs can be used for troubleshooting purposes. See *Figure 40* for jumper plug placements.



*The DX4010 draws more current when the diagnostic LEDs are enabled. Do not enable the diagnostic LEDs under normal operating conditions.*

Diagnostic LED Pins (P2)

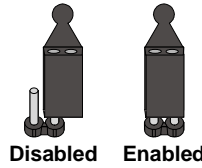

Cable Ground Pins (P3)

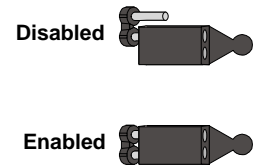

Figure 40: DX4010 P2/P3 Jumper Pin Settings

- **BUS RX LED:** SDI bus receives data from control panel.
- **BUS TX LED:** SDI bus transmits data to control panel.
- **SER RX LED:** RS-232 receives data from printer (or other serial device connected to DX4010).
- **SER TX LED:** RS-232 transmits data to printer (or other serial device connected to DX4010).

#### P3 – RS-232 Cable Ground Pins

Some devices connected to the DB9 connector may cause a ground fault condition on the control panel. If this occurs, removing the plug across the P3 jumper pins may clear the ground condition.

Some devices can cause a ground fault even if the P3 jumper plug is removed.

- **P3 Jumper Pins Disabled:** Isolate DB9 Shield from SDI Common (Black)
- **P3 Jumper Pins Enabled:** Connect DB9 Shield to SDI Common (Black)

#### Address DIP Switches

Use the address DIP switches to assign Address 250 to the DX4010 when a serial device is connected to it. Set the DIP switches to Address 0 (zero) when performing a remote programming direct connection. See *Figure 41* for proper DX4010 DIP Switch positioning, and *Table 18* for DX4010 address settings.

Address 0 (zero) Settings

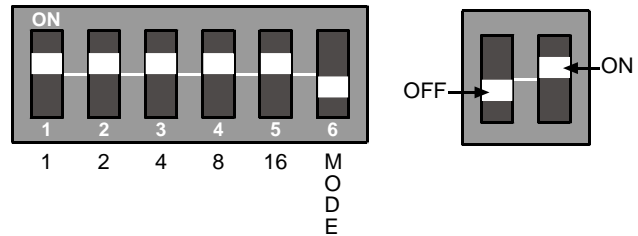

Figure 41: DX4010 DIP Switch Orientation

DIP Switch Settings						
DIP Switches	S1	S2	S3	S4	S5	S6
Module Address	1	2	4	8	16	Mode
0	ON	ON	ON	ON	ON	OFF
250	ON	ON	ON	ON	ON	ON

Table 18: DX4010 Address Settings

### 12.3.5 Supervision

Supervision includes operation of the SDI bus, printer paper supply, and serial printer (or device) selected (on-line). The panel sends an SDI Missing Report if it fails to communicate with the DX4010 Module.

#### 12.3.6 DX4010 Module's DB9 Connector

The DB9 pins are configured as shown in *Figure 42*.

- 1 - DCD      4 - DTR      7 - RTS
- 2 - RxD      5 - GND      8 - CTS
- 3 - TxD      6 - DSR      9 - RI

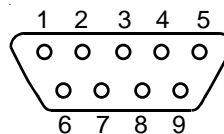

Figure 42: DX4010 D89 Connector Layout

## Installer's Keypad and Installer Mode

### 13.0 Installer's Keypad and Installer Mode

#### 13.1 Installer's Keypad Connector



*The Installer's Keypad must be set to Address 0 (set MODE to OFF) and the Installer Switch must be closed in order to program the panel from the keypad.*

Figure 43 shows you how to connect and disconnect an Installer's Keypad (D623 or D625 Text Command Center) and enter the Installer's Mode. Refer to *D6412/D4412 Program Entry Guide* (P/N: 45351) for complete information on programming the panel from a keypad.

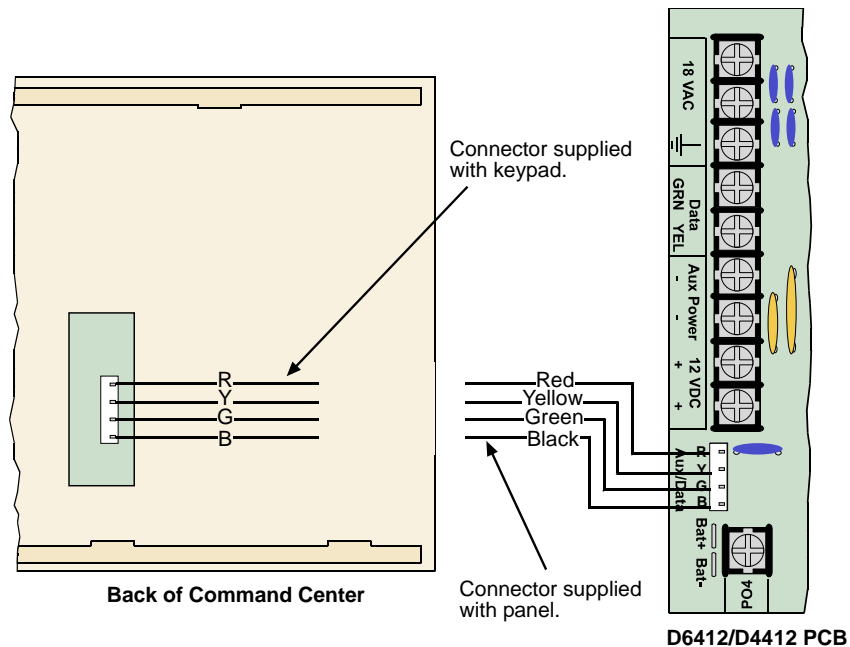

Use wire assemblies supplied with keypad and panel to create a double ended "installer" cable.

Figure 43: Installer's Keypad

#### 13.2 Entering the Installer Mode



*Press the [Cmd] key when the Text Command Center display prompts you to press the [#] key.*

##### 13.2.1 Installer's Passcode

To enter the Installer's Mode, first enter the installer's passcode and then press [Cmd][4][1]. The default Installer Passcode is 6543210. The passcode length can be between 3 and 7 digits in length. The default length is four digits, which shortens the default Installer passcode to 6543. To change the default passcode length, see *Section 2.9 Passcode Configuration, Installer Passcode* in the *D6412/D4412 Program Entry Guide* (P/N: 45351).

The system displays the Installer's Menu described in *Section 13.3 Installer's Menu*.



*The Installer Switch must be closed to select Keypad Program from the Installer's Menu (see Figure 43).*

## Installer's Keypad and Installer Mode

### 13.2.2 Service Start/Service End Reports

After you enter your installer passcode and press [Cmd 41] to enter the Installer's Mode, the panel sends a Service Start Report. When you exit the Installer's Mode, it sends a Service End Report.

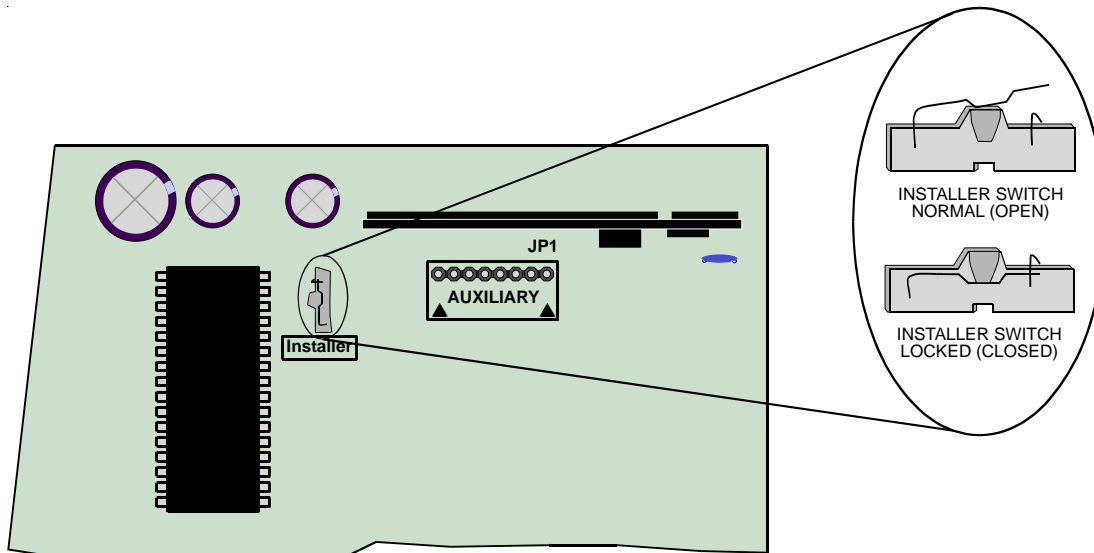

Figure 44: Installer Switch

## 13.3 Installer's Menu

### 13.3.1 Press [1] for Bell Test

The panel activates the Bell Time (1-5) and Alarm Output (1-8, 1-9, 1-10, 1-11, and 1-12.) functions for 3 seconds. See *Outputs* in the *D6412/D4412 Program Entry Guide* (P/N: 45351) for a complete description of output functions.

### 13.3.2 Press [2] for Strobe Test

The panel activates the Strobe Output function (1 to 9) and waits for the installer to press the [Cmd] key to end the test. If the installer fails to press the [Cmd] key within 20 min., the panel automatically terminates the strobe test.

### 13.3.3 Press [3] for Battery Test

The battery test causes the system to run on battery only for four min. If the battery voltage falls below 12.1 V during the four min. test or if the battery is missing, the system restores AC power and displays a system trouble at all keypads.

### 13.3.4 Press [4] for Test Report

When you press the [4] key, the panel tries to send a Test Report. If there is a system trouble present at the time of the test, the panel sends a Test, Off Normal Report.

The Test Report follows the routing for the Automatic Test Report.

If the test communication is unsuccessful, the panel creates a system trouble and a communication failure.



IMPORTANT

***This Test Report is the only report sent when the Installer Switch is closed. No other reports are sent when the Installer Switch is closed.***

### 13.3.5 Press [5] for Point Status

Pressing [5] displays the sensor loop status for the first location in the system. The location, area, point number, and electrical status (open, short, or normal) are shown. See *Locations* in the *D6412/D4412 Program Entry Guide* (P/N: 45351) for a complete description of the relationship between locations, areas, and points.

Pressing the [\*] key advances the display to the status for the next point.

Pressing the [Cmd] key exits the Point Status Mode.

## Installer's Keypad and Installer Mode

### 13.3.6 Press [6] for Output Test

When you press [6] for Output test, the display shows `Output1, Hold [*] for ON`. Press and hold the [\*] key to turn output on. Press the [\*] key (without holding) to end current output test and to advance to next output. Press [Cmd] to return to the Installer's Menu.

### 13.3.7 Press [7] for RF Menu

Pressing [7] moves the system into the RF Menu. This menu consists of three scrolling choices that allow you to add RF ID codes, test RF devices, and view or remove RF ID codes.

#### 13.3.7.1 Adding RF ID Codes

To add RF ID codes into the system, press [1] when "Add RF ID? Press 1." scrolls across the display. *Figure 45* illustrates what appears on the display.

To add the location shown in *Figure 45* as an RF device to the system (Location 9 is used as an example), press [9] followed by [\*]. The RF ID code appears as shown in *Figure 46*.

Enter the nine-digit ID code found on the back of the RF device and then press [Cmd]. "ID added. Press Cmd." appears on the second line of the display, indicating the code was successfully entered and accepted. Press [Cmd].

If an error message appears, make sure you enter the code as printed on the back of the device and that you only enter nine digits.

Press [Cmd]. The display returns to the first location designated as an RF device and scrolls through other RF device locations (if any). You may enter the desired location number and add the ID code as described above.

When all RF ID codes have been entered, press [Cmd] once. The first line of the display shows "Configuring RF Please Wait." During this period, the RF Receiver's LED blinks approximately once every second until all ID bytes have been recognized. If the devices are successfully configured, the display returns to the scrolling RF Menu.

If an error message appears, make sure the RF Receiver's transmit lines are properly connected to the D6412/D4412 and no shorted conditions are present.

From the RF Menu, you may choose 1 to enter additional RF ID codes or you may select one of the other RF Menu choices. When you have finished with the RF Menu, press [Cmd] to return to the main programming menu.

- Locations 41 to 44: RF Keypads (four maximum; one per location)
- Locations 45 to 76: RF Keyfobs

#### 3.3.7.2 Testing RF Devices

To test RF devices that have been added to the system, press [2] when Test RF Devices? Press 2 scrolls across the display. *Figure 47* shows what the appears in the display.

The display scrolls through all properly configured devices and asks if you want to test. Using Location 9 as an example (as shown in *Figure 47*), press [9] followed by [\*] to test the RF device at Location 9. The first line of the display shows `Activate device!`, indicating the device must be activated in order to test it. Once the device is activated, the display shown in *Figure 48* appears:

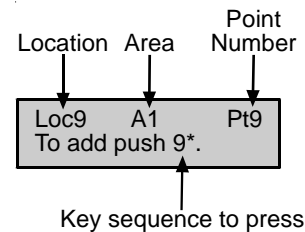

Figure 45: Adding RF ID Codes Menu Display

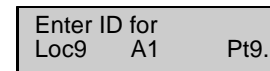

Figure 46: RF ID Code Display

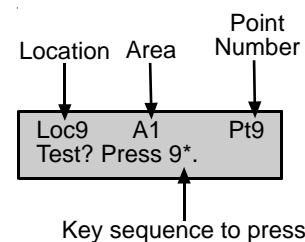

Figure 47: Test RF Devices Display

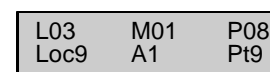

Figure 48: RF Device Test Status Display

## Installer's Keypad and Installer Mode

The first line in *Figure 48* shows the RF device's test status:

- **L03:** System recognizes the device and that the device is operating properly. Other status displays include:
  - **L02:** System recognizes the device and that the device operation is fair.
  - **L01:** The device must be relocated to allow for proper operation.
- **M01:** Counts the number of device activations. For example, an RF3401 Point Transmitter is the device being tested. When the magnetic assembly is removed from the point transmitter base, the activation counter tallies one activation. When the magnetic assembly is returned to the point transmitter base, the counter tallies a second activation. Opening and closing the point transmitter's case are also considered activations.
- **P08:** Message packet transmission.
  - Alarm, Panic and Restoral messages are transmitted with eight packets (Alarm and Restoral refer to the transitions in and out of alarm conditions).
  - Supervisory and Test transmissions (smoke detectors) consist of four packets.
  - RF keypads transmit four packets for all keys except the Emergency keys, which transmit eight packets.
  - RF key fobs transmit four packets for normal operation and eight packets for the Panic button (Arm and Disarm pressed simultaneously).

RF receivers need to receive seven or eight data packets from a transmitter in order for that transmitter to be considered "Good." When testing RF keypads or key fobs, the panic functions must be used, otherwise the units only transmit four packets (see packet count above). When testing the installation of a smoke unit, the test button should not be used. Doing so results in a 4 packet transmission.

When you have finished testing a device, press [Cmd]. The list of RF devices begins to scroll beginning with the first (lowest) location assigned to an RF device. You may select another location to test by entering the location number followed by the [\*] and repeating the procedure described above. If you are finished testing, press [Cmd] again to display the RF Menu.

### 3.3.7.3 Viewing/Removing RF ID Codes

To view or remove RF ID codes that have been added to the system, press [3] when View or Remove RF ID? Press 3 scrolls across the display. The display then scrolls through the properly configured RF devices as shown in *Figure 49*.

After each ID code is shown, the display toggles to the following message before moving to the next ID code: To remove ID press 9\* (the number "9" represents the location number and is used as an example here and in *Figure 49*).

To remove the ID code, press the number key(s) that corresponds with the location number (for this example, [9]). Then press the [\*] key. The display then asks you to confirm your removal. Press the appropriate number key(s) followed by the [\*] key. The display shows *Removed ID* on the first line with the location, area, and point numbers of the removed ID on the second line.

If you want to remove additional ID codes, press [Cmd]. The scrolling list of RF devices returns. Press [Cmd] again to return to the RF Menu when you have finished removing all ID codes. Pressing [Cmd] a third time returns to the Main Programming Menu.

### 13.3.8 Press [8] for Keypad Program

Pressing [8] moves the system into keypad programming mode *ONLY* if the Installer Switch is closed (see *Figure 44*).



**IMPORTANT**

**Keypad programming must be enabled. The default setting enables keypad programming. See the D6412/D4412 Program Entry Guide (P/N: 45351) for more information.**

See *Appendix E Keypad Programming* in the *D6412/D4412 Program Entry Guide* for complete instructions for programming from the keypad.

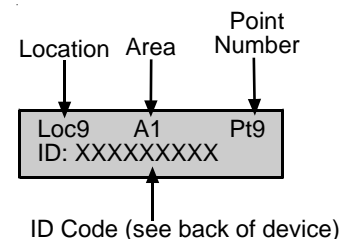

**Figure 49: RF ID Code Display**



## Installer's Keypad and Installer Mode

### 13.3.9 Press [9] Program Key

The PK32 Programming Key functions much like a blank floppy disk and can be used to copy a system's programming to another system. This key can also be used as a backup in the event that the system's programming entries are lost.

To access the PK32 Programming Key Menu, press [9] from the main programming menu. This menu contains the following selections:

- **Key to Panel:** Press [1] to send information from the Programming Key to the panel.
- **Panel to Key:** Press [2] to send information from the panel to the Programming Key.
- **Check Key:** Press [3] to perform a functional diagnostic on the Programming Key. The status LED on the Programming Key blinks during the check. When the display shows Check OK, the Programming Key is OK for use. Press [Cmd] to abort the check.
- **Erase Key:** Press [4] to erase the contents of the Programming Key.



*A panel program stored on a PK32 key can only be used on like panel types (D6412 to D6412 and D4412 to D4412).*

The PK32 connects to the pins marked AUXILIARY (JP1) on the panel's PCB as shown in *Figure 50*.

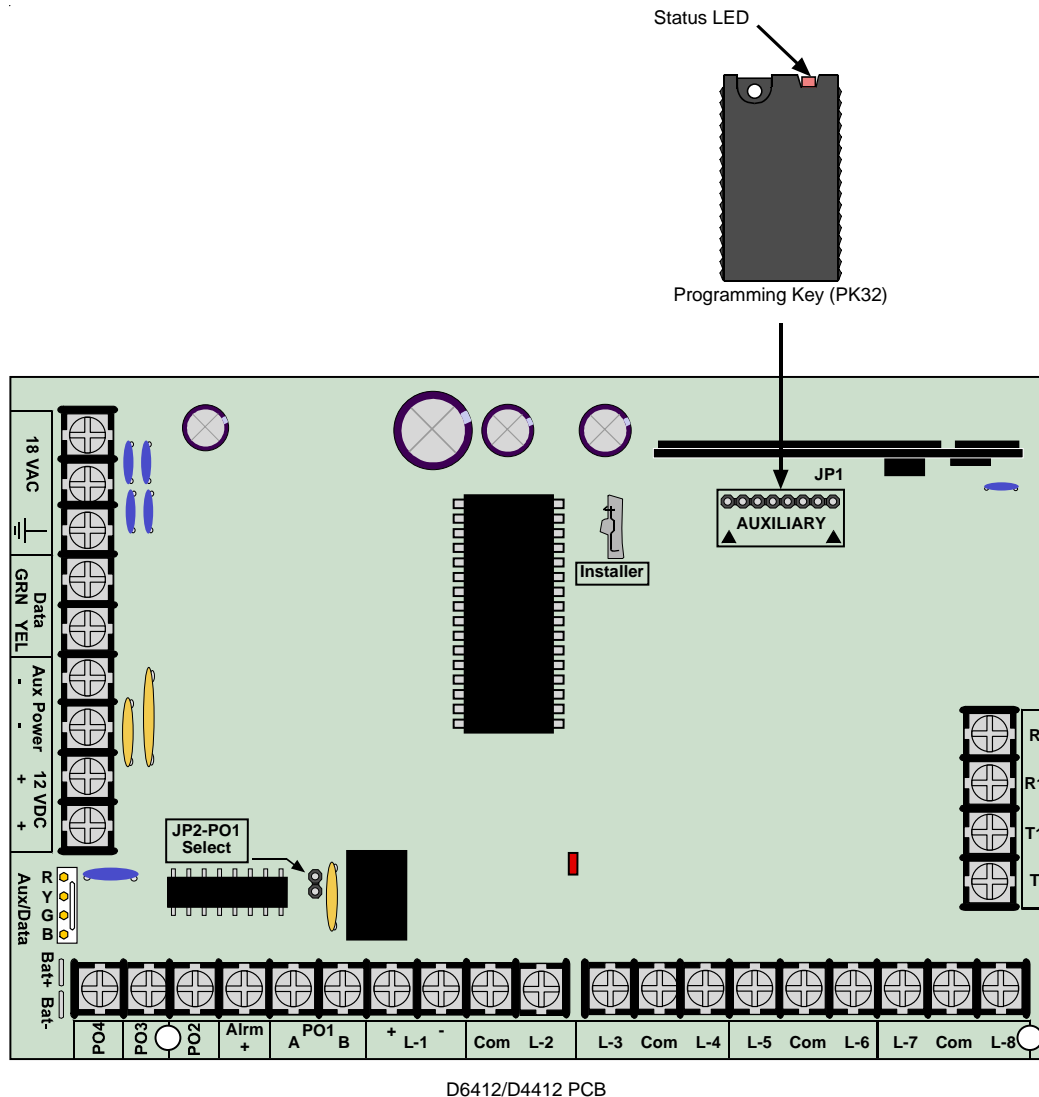

Figure 50: PK32 to D6412/D4412 Connections

## Installer's Keypad and Installer Mode

### 13.3.10 Exiting the Installer's Menu

When you are ready to exit the Installer's Menu and return the system to normal operation, open the Installer's Switch. The following screen appears for approximately 10 sec. (note that the panel model number may vary).

```
D6412          Rev X.XX  
Please Wait...
```

After the 10-sec. waiting period, the text command center display returns to normal (disarmed, no fault/trouble conditions).

### 13.3.11 Press [0] Call for Service Details

When end users press [Cmd 42] to display system troubles and a Call for Service condition exists, the system displays `Call for Service`.

The first line of the display is fixed. The second line is programmable text that can be used to enter the preferred phone number to use if a call for service must be placed. This number could be the central station's phone number or a different number. The second line can also be used to show an instructional message, such as "PRESS 0 TO VIEW." This message instructs the user to press the [0] key to view system trouble details.

There is a variety of system conditions that can access the Call for Service display. The exact nature of the trouble is not shown to the end user because none of the conditions can be serviced by them. These conditions require attention of the servicing company.

#### Call for Service Details

**Comm Fail, Destination 1 [2]:** System tried to send report to this routing destination but failed. See Appendix A Routing Dialing Tables in the D6412/D4412 Program Entry Guide (P/N: 45351) for details on the communication failed event.

**System battery is low:** Battery connected to the panel fell below 12.1 V.

**System battery is missing:** Battery connected to the panel is badly discharged, damaged, or disconnected.

**Data bus missing, Device ##:** SDI data bus device set to the address shown in the display (##) is missing or has stopped responding.

**Data bus tamper, Device ##:** Tamper on the SDI data bus device set to the address shown in the display (##) is open.

**Data bus reset, Device ##:** SDI data bus device set to the address shown in the display (##) has reset its microprocessor.

**Data bus trouble, Device ##:** SDI data bus device set to the address shown in the display (##) is sending a trouble message to the panel. Troubles are defined per device type. See the instructions for the device shown to learn the exact nature of the trouble.

**Bell supervision fault PO2:** Programmable Output 2 (marked PO2 on the panel) can be programmed as a supervised siren/speaker. See Outputs in the D6412/D4412 Program Entry Guide (P/N: 45351). When PO2 is programmed for supervision, disconnecting the siren or speaker generates this fault condition.

**RF Rcvr Trouble, Device ##:** Premises RF receiver set to the displayed SDI address (Device ##) is sending a trouble message to the panel. Troubles are defined per receiver type. See the instructions for the receiver shown to learn the exact nature of the trouble.

**RF Rcvr Jammed, Device ##:** Premises RF receiver set to the displayed SDI address (Device ##) is sending a jammed message to the panel.

14.0 Installation Label

# BOSCH

## D6412

This system should be installed in accordance with the National Electrical Code, NFPA 70, the National Fire Alarm Code, NFPA 72 and the local authority having jurisdiction. Depending on the application, the installation is to be in accordance with one or more of the following UL standards: UL681 Installation and Classification of Mercantile and Bank Burglar Alarm Systems; UL1076 Proprietary Burglar Alarm Systems and Units; UL1641 Installation and Classification of Residential Burglar Alarm Systems. Printed information describing proper installation, operation, testing, maintenance, repair service and response to an alarm is to be provided with this equipment.

**Warning:** Owner's Instruction Notice: Not to be removed by anyone except occupant.

---

Bosch Security Systems recommends testing the entire system at least once a week, and having a qualified technician check the system at a minimum of once every 3 years.

This equipment has been type tested and found to comply with the specifications in Part 15 of FCC rules for Class B Computing Devices. Operation is subject to the two following conditions (1) this device may not cause any interference, and (2) this device must accept any interference received including interference that may cause undesired operation. Complies with Part 68, FCC Rules. **FCC Registration Number:** ESVMUL-46531-AL-E 0.1B

---

Suitable for the following applications: 1) Household Burglar Alarm System Units, Grade A. 2) Household Fire Warning System Units. 3) Police Station connect, Grade A Mercantile Premise alarm system, Grade A Mercantile Safe and Vault alarm system and Grade AA Mercantile Safe and Vault alarm system when installed in conjunction with Model D8122 derived channel subscriber terminal unit. For all Police Station applications and grades, Model D8108A Attack Resistant Enclosure with a UL Listed local sounding device is required. 4) Local, Grade A Mercantile Premise alarm system and Grade A Mercantile Safe and Vault alarm system. For all local applications and grades, Model D8108A Attack Resistant Enclosure and a UL Listed local sounding device is required. 5) Central Station, Grade C application. Central Station, Grade B when installed with a UL Listed local sounding device. Central Station, Grade AA when installed with Model D8122 derived channel subscriber terminal unit. 6) Proprietary Burglar Alarm units, Grade A. Proprietary Burglar Alarm unit, Grade BB when installed with the Model D8122 derived channel subscriber terminal unit. **D6412 must be installed in accordance with D6412/D4412 Installation Instructions (P/N:45349).**

---

Do not connect to a receptacle controlled by a switch. Do not share with other equipment.

D6412 uses a CX4010 UL Listed Class 2 Transformer 18 VAC 22 VA 60 HZ

Earth Ground

Green — Data

Yellow — Data

Black — Aux Pwr -

Red — Aux Pwr +

Keypads, Expanders Printer modules & Communication modules (up to 19 total devices)

Supervised with 2.2 kΩ EOL Resistor (P/N: 47819)

Typical Initiating Devices are Door Contacts NO/NC, Floor Mats, Motion Sensors, Glass Break Detectors, etc.

Maximum charging current is 1.1 A.

**BATTERY:** Replace every 3 to 5 years. Use Bosch Security Systems Model D126, 12 V 7 Amp HR Sealed Lead Acid Battery for Burglary or Combination Fire and Burglary Systems. For additional load or standby power, refer to battery calculation sheet in D6412/D4412 Installation Instructions (P/N:45349).

\* Not investigated by UL.

All external connections are inherently Class 2 power limited.

Circuit (Loop)	Control Unit Delay - Sec	Smoke Detector Model	Smoke Detector Delay - Sec
1	16 sec		(a)

(a) The delay (power-up) (start-up) time marked on the installation wiring diagram of the smoke detector or on the installed smoke detector(s) is to be used.

Auxiliary Powered Devices 11.5 to 12.4 VDC. Below 10.2 VDC, the D6412 stops processing Loop inputs. With 7.0 Ah battery, 120 mA for 24 hrs for Fire and Combined Fire/Burglary, 400 mA for 4 hrs for UL Burglary, 600 mA for other\* Include keypads in calculations.

**POWER SUPPLY REQUIREMENTS** The Power Supply provides a maximum of 600 mA for the Control Panel and All Accessory Devices. For System loading, See D6412/D4412 Installation Instructions (P/N:45349). Requirements for battery standby time may reduce allowable output.

**CAUTION:** See D6412/D4412 Installation Instructions (P/N:45349) for power requirements relating to terminals [Alarm+] and [+Aux].

Installer Keypad Connect Lock Installer Switch to program.

JP2

PO1 Terminals can be configured as an alarm power output. JP2-PO1 Jumper must be closed.

Note 1: A supervisory alarm output module must be used on these terminals for household fire applications

Note 2: Jumper J2-PO1 must be in place for connection to NAC or other powered alarm device.

PO4 PO3 PO2

Alarm Output + Alarm Output - (see Note 2)

see Note 1

Use compatible NAC such as Bosch Security Systems D440

400 mA for Fire and Combined Fire/ Burglary;

1500 mA for UL Burglary;

1850 mA for other\*

Applies to all four outputs combined.

Supervised Loops

Open	7.7 to 14.0 VDC
Normal	6.3 to 7.3 VDC
Short	0.0 to 6.0 VDC

2.2 kΩ Resistor (P/N:47819) Required at End of Line

Powered Sensor Loop suitable for Two-Wire Smoke Detectors 2.2 kΩ Resistor required at End of Line. For compatible smoke detectors, see D6412/D4412 Technogram (P/N:46928). **The UL Panel Compatibility Identifier = B.** Also available for Four-Wire Smoke Detectors such as Bosch Security Systems D273TH.

P/N 25899

See D6412/D4412 Installation Instructions (P/N:45349) for System Wiring Diagram

Installer Switch Disables Arming, Reports, and Relays. Lock for local programming.

R — Red

R1 — Gray

T1 — Brown

T — Green

Premises Phone

Use Bosch Security Systems D164 Phone Cord or equivalent. Ground Start requires D133/D134.

Incoming Phone Line

---

**WARNING: THIS UNIT INCLUDES AN ALARM VERIFICATION FEATURE FOR L-1 (LOOP 1) THAT RESULTS IN A DELAY OF THE SYSTEM ALARM SIGNAL WHEN PROGRAMMED FOR THIS FEATURE. THE TOTAL DELAY (CONTROL UNIT PLUS SMOKE DETECTORS) SHALL NOT EXCEED 60 SECONDS. NO OTHER INITIATING DEVICES SHALL BE CONNECTED TO LOOP 1 WHEN PROGRAMMED FOR ALARM VERIFICATION, UNLESS APPROVED BY THE LOCAL AUTHORITY HAVING JURISDICTION.**

This box will be checked if L-1 is programmed for Alarm Verification.

P/N:48259G 10/02  
© 2002 Bosch Security Systems

D6412/D4412 Operation and Installation Guide

© 2003 Bosch Security Systems

Page 59

45349E

Installation Label

# BOSCH

## D4412

This system should be installed in accordance with the National Electrical Code, NFPA 70, the National Fire Alarm Code, NFPA 72 and the local authority having jurisdiction. Depending on the application, the installation is to be in accordance with one or more of the following UL standards: UL681 Installation and Classification of Mercantile and Bank Burglar Alarm Systems; UL1076 Proprietary Burglar Alarm Systems and Units; UL1641 Installation and Classification of Residential Burglar Alarm Systems. Printed information describing proper installation, operation, testing, maintenance, repair service and response to an alarm is to be provided with this equipment.  
**Warning:** Owner's Instruction Notice: Not to be removed by anyone except occupant.

Bosch Security Systems recommends testing the entire system at least once a week, and having a qualified technician check the system at a minimum of once every 3 years.

This equipment has been type tested and found to comply with the specifications in Part 15 of FCC rules for Class B Computing Devices. Operation is subject to the two following conditions (1) this device may not cause any interference, and (2) this device must accept any interference received including interference that may cause undesired operation. Complies with Part 68, FCC Rules. **FCC Registration Number:** ESVMUL-46531-AL-E 0.1B

Suitable for the following applications: 1) Household Burglar Alarm System Units, Grade A. 2) Household Fire Warning System Units. 3) Police Station connect, Grade A Mercantile Premise alarm system, Grade A Mercantile Safe and Vault alarm system and Grade AA Mercantile Safe and Vault alarm system when installed in conjunction with Model D8122 derived channel subscriber terminal unit. For all Police Station applications and grades, Model D8108A Attack Resistant Enclosure with a UL Listed local sounding device is required. 4) Local, Grade A Mercantile Premise alarm system and Grade A Mercantile Safe and Vault alarm system. For all local applications and grades, Model D8108A Attack Resistant Enclosure and a UL Listed local sounding device is required. 5) Central Station, Grade C application. Central Station, Grade B when installed with a UL Listed local sounding device. Central Station, Grade AA when installed with Model D8122 derived channel subscriber terminal unit. 6) Proprietary Burglar Alarm units, Grade A. Proprietary Burglar Alarm unit, Grade BB when installed with the Model D8122 derived channel subscriber terminal unit. D4412 must be installed in accordance with D6412/D4412 Installation Instructions (P/N:45349).

Do not connect to a receptacle controlled by a switch. Do not share with other equipment.

All external connections are inherently Class 2 power limited.

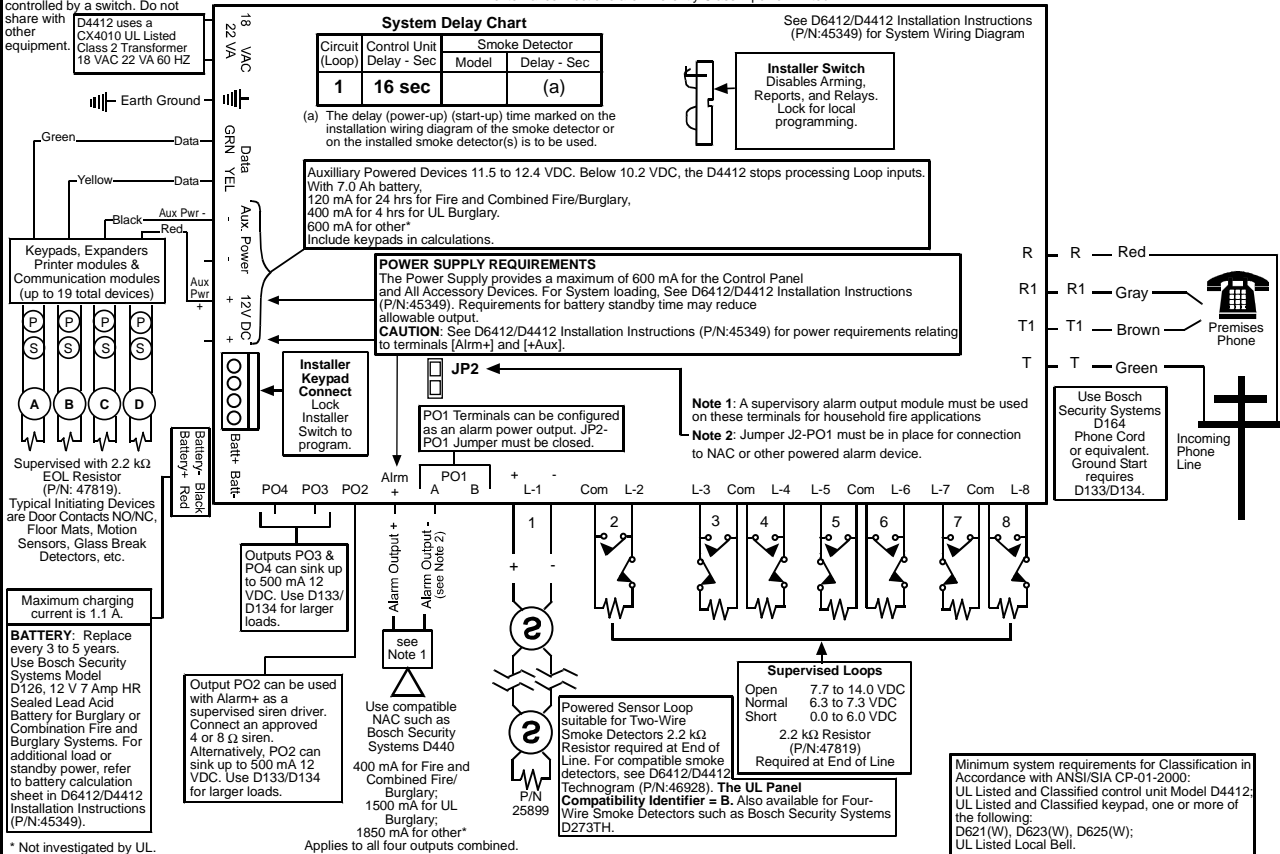

**WARNING:** THIS UNIT INCLUDES AN ALARM VERIFICATION FEATURE FOR L-1 (LOOP 1) THAT RESULTS IN A DELAY OF THE SYSTEM ALARM SIGNAL WHEN PROGRAMMED FOR THIS FEATURE. THE TOTAL DELAY (CONTROL UNIT PLUS SMOKE DETECTORS) SHALL NOT EXCEED 60 SECONDS. NO OTHER INITIATING DEVICES SHALL BE CONNECTED TO L-1 WHEN PROGRAMMED FOR ALARM VERIFICATION, UNLESS APPROVED BY THE LOCAL AUTHORITY HAVING JURISDICTION.

This box will be checked if L-1 is programmed for Alarm Verification.

P/N:50487D 10/02  
 © 2002 Bosch Security Systems

## 15.0 Terminal Quick Reference

Term	Silkscreen (below terminals)	Description
1,2	18 VAC	18 V, 22 VA; up to 15.3 m (50 ft.), #18 AWG (1.2 m), Stranded
3	Earth Ground Symbol	Earth Ground
4	Data, Grn (Green)	SDI data on Terminals 4 & 5. Panel supports up to 1000 ft. (305 m) of #22 AWG (0.8 mm) wire on these terminals (any configuration).
5	Data, Yel (Yellow)	
6,7	Aux Power 12 VDC (-)	Terminals 6 to 9 are Aux power, 600 mA. Include any programmable outputs (PO 1 to PO 4) not configured for alarm output. PTC protected.
8,9	Aux Power 12 VDC (+)	
JP3	Aux/Data (RYGB)	4-pin connector to Data bus and Aux power. Use to connect an installer keypad for keypad programming.
	Red (Bat +)	Battery (+) spade.
	Black (Bat -)	Battery (-) spade.
10	PO4	Programmable Output, up to 500 mA (-). Include in Aux Power calculations for all except 'Alarm' output functions. PTC protected
11	PO3	Programmable Output, up to 500 mA (-). Include in Aux Power calculations for all except 'Alarm' output functions. PTC protected
12	PO2	Programmable Output. 500 mA (-). Include in Aux Power calculations for all except "Alarm" output functions. Supervised for Horn/Speaker alarm function. PTC protected.
13	Alrm +	Alarm power. Up to 1,850 mA. PTC protected. Provides power for supervised siren driver (PO 2) and Alarm Output (PO 1).
14	PO1, A	Jumper sets PO 1 terminals A (14) and B (15) for 'dry' Form "A" contact or for Alarm Output.
15	PO1, B	
16	L-1 (+)	Positive terminal of powered loop. Supports up to 15 smoke detectors (see the D6412/D4412 Smoke Compatibility List, P/N: 46928). PTC protected.
	L-1 (-)	Negative terminal of powered loop.
18	Com	Common for Sensor Loop 2.
19	L-2	Sensor Loop 2 input. Wire length for Sensor Loops 2 to 8 are limited only by the resistance on the loop and potential EMI problems. Resistance must be < 100 $\Omega$ with EOL resistor shorted and detection devices connected.
20	L-3	Sensor Loop 3 input.
21	Com	Common for Sensor Loops 3 and 4.
22	L-4	Sensor Loop 4 input.
23	L-5	Sensor Loop 5 input.
24	Com	Common for Sensor Loops 5 and 6.
25	L-6	Sensor Loop 6 input.
26	L-7	Sensor Loop 7 input.
27	Com	Common for Sensor Loops 7 and 8.
28	L-8	Sensor Loop 8 input.
29	T	Tip of telephone line.
30	T1	Tip of house (premises) phones.
31	R1	Ring of house (premises) phones.
32	R	Ring of telephone line.
	JP2, PO1 Select $\sphericalangle$	Configures PO 1 for Form "A" relay or Alarm Output.
	Auxiliary	Auxiliary Module and/or Programming Key Header.
	Installer	Installer Jumper. Jumper required for keypad programming.

**Notes:**

## 16.0 Troubleshooting

### 16.1 Introduction

Bosch Security Systems provides this guide to help you troubleshoot panel problems. To prevent problems from occurring, read the preceding sections of this guide and the *D6412/D4412 Program Entry Guide* (P/N: 45351) to verify the panel is correctly installed and programmed. Explanations of the problems (causes) and solutions are included in the following charts.

#### 16.1.1 Arming Issues

Problem	Cause	Solution
Entered valid passcode to arm an area, but the area does not arm.	No points are programmed for that area; user does not have appropriate authority level to arm system.	<ul style="list-style-type: none"> <li>Add a minimum of one point to each area.</li> <li>Make sure all users who should be able to arm/disarm the system have the appropriate authority level. See <i>Authority Level Configuration</i> in the <i>D6412/D4412 Program Entry Guide</i> (P/N: 45351).</li> </ul>
Cannot tell if my panel is Part On armed or Part 2 armed.	Command Center does not display which Part On arming feature is currently in use. There is no solution. The user who turns on the system must know which keys were pressed (Cmd 2 is Part On; Cmd 3 is Part 2 On). This only affects panels with Firmware v1.03 or lower.	N/A
Armed my panel All On, but it keeps changing to Part On all by itself.	All On – No Exit arming option is enabled. When the panel was armed, nobody faulted an Exit Delay Point; therefore, the panel did not arm those internal points.	To disable this feature, see the <i>D6412/D4412 Program Entry Guide</i> (P/N: 45351), <i>Global Open/Close Options, Arming Options 1</i> (Nibble 0258).

#### 16.1.2 Point Issues

Problem	Cause	Solution
Trouble on keyswitch point and it will not clear. Point is restored to normal condition.	Swinger Bypass may be enabled on this point index. The point will not restore until the Swinger Bypass condition restores.	Arm and disarm panel to clear current trouble. To prevent this in the future, check the keyswitch point index programming and make sure Swinger Bypass feature is disabled.
Independent Zone Controller does not generate a "point fault" on command center when it's disarmed. 9000 Series panels show a point fault during this condition.	This is normal panel operation.	N/A
Command center shows Point 1 as faulted even though the 1K EOL resistor is in place.	EOL Resistor Value Nibble (Nibble 1026) is programmed for 1K EOL resistors, and Point 1 always requires a 2.2K EOL resistor.	Replace the 1K EOL resistor on Point 1 with a 2.2K EOL resistor.
No output after alarming a point.	N/A	Review the following sections in the <i>D6412/D4412 Program Entry Guide</i> (P/N: 45351): <i>Outputs</i> , and <i>Point Index Configuration, Point Index Option 2</i> .

## Troubleshooting

### 16.1.3 Command Center Issues

Problem	Cause	Solution
Entered Cmd 50 at my Command Center but it does not let me move to specific areas.	Cmd 50 (Move to Area) is disabled if there are no points assigned to a particular area.	Program at least one point and assign it to the particular area. Cmd 50 should work as defined.

### 16.1.4 Programming Issues

Problem	Cause	Solution
Cannot enter into Programmer's Mode.	One or more areas are armed; keypad programming may be disabled; Installer's Switch may be open.	<ul style="list-style-type: none"> <li>If one or more areas are armed, disarm all armed areas. Programmer's Mode cannot be entered while one or more areas are armed. However, an Installer's Keypad can access the Programming Mode regardless of the panel's arming state.</li> <li>Programming may be disabled. See <i>Programming Options, Installer Switch, and Daylight Savings Time Options (Nibble 0257)</i> in the <i>D6412/D4412 Program Entry Guide</i> (P/N: 45351.) Make sure the following options are enabled: Installer Switch, Keypad Programming, and PK32 (Programming Key).</li> <li>To enter Programmer's Mode, the Installer Switch must be closed. See the following sections in this installation guide for details: <i>3.4.2 Closing the Installer Switch</i> and <i>13.2 Entering the Installer Mode</i>.</li> </ul>
Enabled Open/Close Reports, but when in the Panel Part On Mode, these reports are still not sent.	Open/Close Reports for Part On Mode is not programmed correctly.	In <i>Areas of the D6412/D4412 Program Entry Guide</i> (P/N: 45351), see the <i>Area # Opening/Closing Reporting Options</i> parameter. Enable "Opening/Closing Reports for Part On Modes" for Nibbles 0296, 0318, 0340, and 0362.
PK32 does not work (upload, download, erase, etc.)	PK32 has not been enabled in the panel firmware.	In Nibble 0257, enable PK32. See <i>Section 2.5 Programming Options</i> in the <i>D6412/D4412 Program Entry Guide</i> (P/N: 45351).
The off-board points added to the system display as missing.	Device Location parameter is not programmed correctly.	See <i>Locations</i> in the <i>D6412/D4412 Program Entry Guide</i> (P/N: 45351). Verify which device type was added (e.g., RF point, off-board point, etc.). In the Device Location parameter, enter the correct value based on the Device Parameter Selections (1 = on-board; 2 = DX2010; 3 = DX2010, Doubled; 4 = RF Receiver 1; 5 = RF Receiver 2). Point configuration is locked into only those configuration types in the Device Parameter Selections.
Panel is not following report routing as programmed.	Lock Area Reporting parameter is enabled.	Set the Lock Area Reporting parameter to 0 (disabled). See the <i>D6412/D4412 Program Entry Guide</i> (P/N: 45351) for more information.

### 16.1.5 Miscellaneous Issues

Problem	Cause	Solution
Entered Cmd 50 at my Command Center but it won't let me move to specific areas.	Cmd 50 (Move to Area) is disabled if there are no points assigned to a particular area.	Program at least one point and assign it to the particular area. Cmd 50 should work as defined.



---

## Appendix A: Approved Applications Compliance Guide

### Appendix A: Approved Applications Compliance Guide

#### A-1 Listings and Approvals

##### Fire

- UL
- CSFM
- NYC-MEA - Approved by New York City's Materials and Equipment Acceptance System.

##### Burglary

- UL
- SIA

##### Introduction

The *System Chart* references components evaluated and listed by Underwriters' Laboratories for compatibility with the control panel. These components meet the basic system requirements for the applicable standard.

The *System Wiring Diagram, Issue A* shows the relationship between the panel and the accessory components referred to in the *System Chart*.

##### Optional Compatible Equipment

You can use UL Listed components that do not require evaluation for electrical compatibility in many applications when installed according to the manufacturer's instructions.

##### Burglary Applications

You can use UL Listed burglary alarm sensors that do not require evaluation for electrical compatibility in burglary applications. In some cases you must use a UL Listed Bosch Security Systems interface module in conjunction with the sensors. Consult the individual component specification and installation documents to determine suitability.

**Test weekly:** UL Standard 1023 requires a weekly test for residential burglary applications.

##### Auto Arming for Bank Safe/Vault Applications (UL 609)

To auto-arm for Bank Safe/Vault applications, use an Auto On/Auto Off Sked (schedule). Set the Auto On Sked to arm the system on a 7 day (1 week) timer no later than 10 p.m. Set the Auto Off Sked to disarm the system no sooner than 6 a.m. the next business day. Adjust these skeds so that the system is armed during non-business hours (such as holidays and weekends). These times may be adjusted if they conflict with normal business hours and/or any non-business hour carry-over (extended holiday/closed periods). See *Skeds* in the *D6412/D4412 Program Entry Guide* (P/N: 45351) for Sked setup instructions.

##### Fire Applications

You can use UL Listed fire initiating devices not requiring electrical compatibility evaluation in any application. For example: four-wire smoke detectors, heat detectors, water flow switches, and manual pull stations are suitable fire initiating devices. Consult the individual component specification and installation documents to determine suitability.

Two-wire smoke detectors only connect to the panel on the sensor loop for Location 1. Two-wire detectors must be evaluated for electrical compatibility, and must be UL listed for use with the panel. See the Bosch Security Systems *D6412/D4412 Technical Service Note: Smoke Detector Compatibility* (P/N: 46928), or you may contact the detector manufacturer.

When using four-wire smoke detectors, install a suitable power supervision unit according to the manufacturer's instructions. Use the D130 Relay Module, DX3010 Octo-Output or PO1 to provide reset capability. See *Section 9.0 On-Board Outputs* and *Section 10.0 Off-Board Outputs* for details on the installation of the DX3010.

For battery calculations, refer to *Current Rating Chart for Standby Battery Calculations*, *Standby Battery Requirements*, and *Standby Battery Calculation for NFPA 72 Fire Alarm Applications*.

## Appendix A: Approved Applications Compliance Guide

### Enclosures

Bosch Security Systems offers three optional enclosures for the control panel.

1. The **D8103** enclosure is suitable for residential fire and/or burglary installations and commercial burglary applications that do not require attack resistance or approval by Factory Mutual or NYC-MEA. (See *Appendix B: System Chart* for acceptable applications.)
2. The **D8108A** is attack resistant. It is intended primarily for UL commercial burglar alarm and mercantile safe and vault applications requiring a local bell. You can use the D8108A in any burglar or fire alarm application where the 5591 or D8109 enclosure is suitable. UL lists the D8108A for all commercial fire alarm applications. The D8108A is approved by Factory Mutual, California State Fire Marshal, and the New York City Materials and Equipment Acceptance System.
3. The **D8109** is normally used for commercial fire alarm applications. UL lists the D8109 for all commercial fire alarm applications. The D8109 is approved by the California State Fire Marshal, NYC-MEA and FM.



*All references to NFPA and related requirements are based upon compliance with the 1993 edition of NFPA 72, National Fire Alarm Code. Since installation specifications are nearly always based on a specific edition of a standard that has been legally adopted by the Authority Having Jurisdiction (AHJ), earlier editions of NFPA standards generally apply. Consult the appropriate AHJ for confirmation.*

### A-2 System Chart

	Household Burglary (Grade A)	Household Fire	Household Fire/Burglary Combined	Central Station Burglary (Grade C)	Police Connected Burglary	Local Burglary	Mercantile (4 hrs.) Commercial	Mercantile (72 hrs.) Bank Safe/Vault Alarm	Proprietary Burglary
NFP Standard		72	72						
Min.Hrs. of Standby Battery	4	24 hrs. + 4 min.	24 hrs. + 4 min.	4	4	4	4	72	4
Entry/Exit Time (sec.)	45/60	45/60	45/60						
Bell Time (min.)	4	4	4	15	15	15	15	15	15
D2203 Enclosure	Included w/panel			No	No	No	No	No	No
D8103 Enclosure*	Optional			Choose One	No	No	No	No	No
D8108A Enclosure	Optional				Req	Req	Req	Req	Req
D8109 Enclosure	Optional				No	No	No	No	No
D126 Battery (7 Ah)	Req	Req	Req	Req	Req	Req	Req	No	Req
D1218 Battery (18 Ah)	Opt	Opt	Opt	Opt	Opt	Opt	Opt	Req	Opt
D127 Reversing Relay	Opt	Opt	Opt	Opt	Opt	Opt	Opt	Opt	Opt
D132A Smoke Detector Reversing Relay Module	Required if D192C is not used. Use D132A with compatible smoke detectors only.								
D164 Telephone Card	Required to connect panel to RJ131X Telco Block								
D192C NAC Supervision Module	Required if D132A and compatible smoke detectors are not used.								
D621, D623, D625 Command Center	1+	1+	1+	1+	1+	1+	1+	1+	1+
D262 Smoke Detector Head/D621 Base		1•	1•						
D282THS Smoke Detector w/ Sounder	Use with D132A.								
D431, D435, D438, D440, D442, D448 Indicating Device	1+	1+	1+	Opt	♦	♦	♦	♦	♦
CX4010 Transformer	Required for all applications.								
D8004 Transformer Enclosure	Opt	Opt	Opt	Opt	Opt	Opt			
D8122 Derived Channel STU	Optional. Contact Telco for the availability of derived channel service.								
D8130 Release Module	Optional								

Key	
No	Not acceptable for this application.
Req	Required for this application.
Opt	Optional for this application.
1+	1 or more required for this application. Consult the appropriate standard.
1•	At least one detector required. You can substitute other 2-wire detectors listed for use with the D6412/D4412. You can use D262 with D270 4-wire detectors. You must use a listed power supervision relay with 4-wire detectors.
♦	UL Listed bell (siren) housing required for burglary alarm bell or siren (Rothenbuhler 5110 Bell).
Empty Cell	Not used for this application.
*	Not to exceed these Entry/Exit Delay limits for UL installations.
**	D101 for this application.

## Appendix A: Approved Applications Compliance Guide

The D6412/D4412 control panel is suitable for Police Station connect applications, including Grade A Mercantile Premises and Grade A Mercantile Safe and Vault alarm systems. Suitable for Grade AA Mercantile Premises and Grade AA Mercantile Safe and Vault alarm systems when the Model D6412/D4412 DACT unit is installed in conjunction with the Model D8122 derived channel subscriber terminal unit. For all Police Station applications and grades, the Model D8108A Attack Resistant Enclosure with a UL Listed local sounding device is required. Per UL 365, keyswitches mounted outside the protected area must employ high security locking cylinders complying with the requirements for key locks, UL 437. Tamper protection must also be provided.

The D6412/D4412 control panel is suitable for Local, Grade A Mercantile Premises and Local, Grade A Mercantile Safe and Vault alarm systems. For all local applications and grades, the D8108A Attack Resistant Enclosure and a UL Listed local sounding device are required. Per UL 609, when keyswitches are mounted outside the protected area, tamper protection must be provided.

The D6412/D4412 control panel is suitable for Central Station, Grade C applications. It is suitable for Central Station, Grade B applications when the Model D6412/D4412 DACT unit is installed with a UL Listed local sounding device. Also suitable for Central Station Mercantile, Grade AA applications when installed with the Model D8122 derived channel subscriber terminal unit.

### A-3 System Wiring Diagrams, Issue A

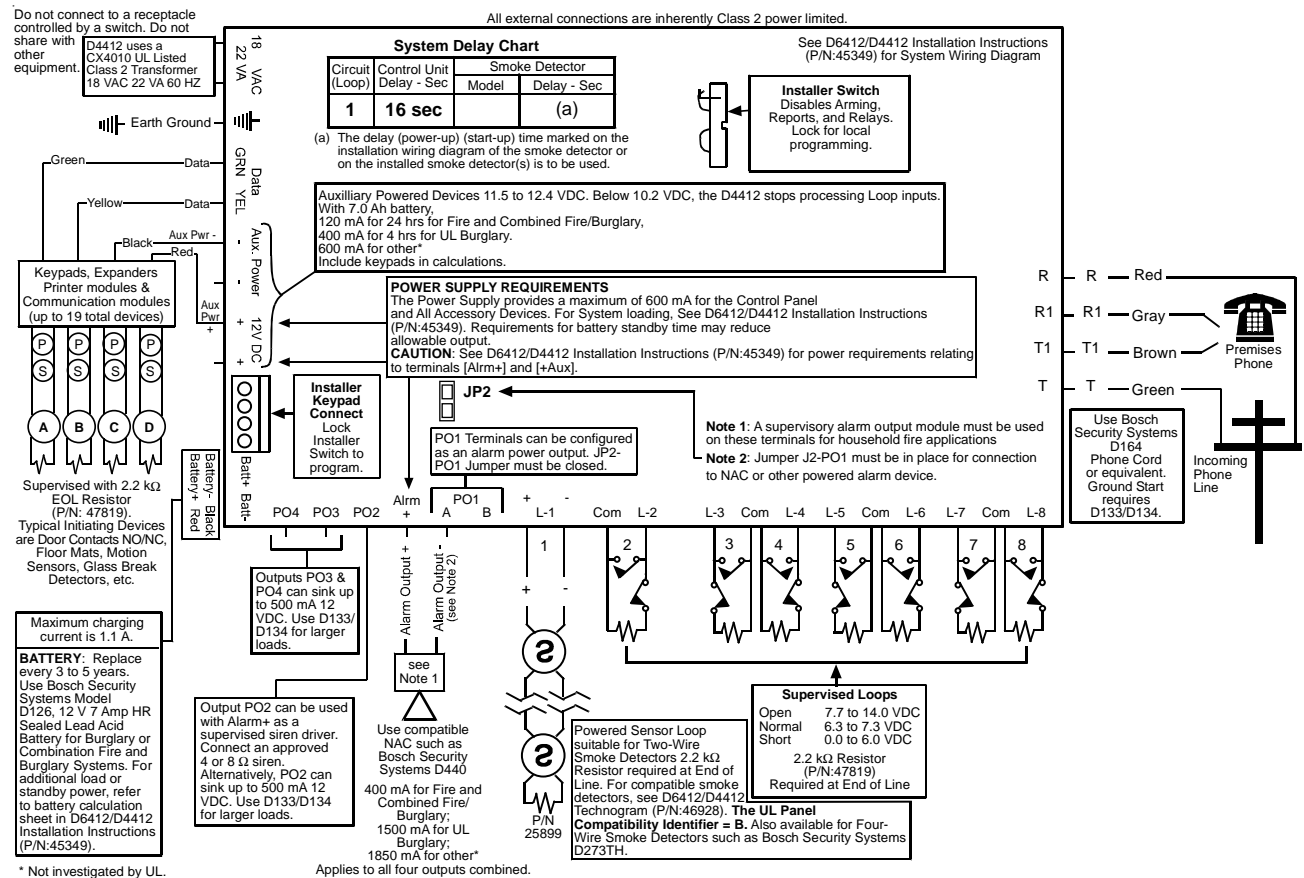



## Appendix B: SDI Address Chart

Panel	SDI Address	Device Description
D6412/D4412	0	Installer Keypad or local connection to RAM IV
D6412/D4412	1 to 8	Command Centers 1 to 8
D6412/D4412	40, 41	DX8010 Telephone Control Module
D6412/D4412	50	Premises RF Receiver 1
D6412/D4412	51	Premises RF Receiver 2
D6412/D4412	52 to 55	Premises RF Keypads Receiver 1
D6412/D4412	60 to 63	Premises RF Keypads Receiver 2
D6412 only	101 to 107	DX2010 Wired Point Expanders
D4412 only	101 to 103, 106	DX2010 Wired Point Expanders
D6412 only	150, 151	DX3010 Octo Outputs and/or DX3020 Module
D4412 only	150	DX3010 Octo Outputs and/or DX3020 Module
D6412/D4412	250	DX4010 Serial RS-232 Interface

**Appendix B: SDI Address Chart**

**Notes:**

<b>24-Hour Points</b>	Points that are always on even when the system is turned off. Two types: Fire Points and Non-Fire 24-Hour Points.
<b>Area</b>	An installer-specified collection of points that can be armed and disarmed independently. An area can report with its own account number. Opening, closing, alarm, trouble, and restoral reports are all associated with an area. You can organize the panel's points and users into a maximum of four areas (two areas max on the D4412), in essence creating four independent systems within one control panel.
<b>All On</b>	All controlled points are armed. All On with No Delay (Instant) is an option. No Exit or Entry Delay is provided with the No Delay option.
<b>Authority Level</b>	A programmable feature that determines what a user can do in a given area.
<b>Burglary Alarm Tone</b>	A constant warble tone.
<b>Central Station</b>	A facility where trained personnel monitor a security system 24 hrs. a day. The security system may be programmed to contact the central station during alarm conditions, enabling central station personnel to dispatch the proper authorities.
<b>Control Panel</b>	A control panel combines the functionality of an alarm control panel and a digital dialer into a single unit.
<b>Controlled Point</b>	A point that responds to alarm conditions depending upon whether the system is turned on or off.
<b>Cross Point</b>	A group of points that are configured to initiate an alarm when two points have been faulted within a programmed time. Fire points cannot be set for Cross Point configuration.
<b>Duress Passcode</b>	A passcode that arms and disarms the system just like a personal passcode, however it sends an alarm signal to the central station without sounding an alarm on the premises.
<b>Entry Delay</b>	A programmed delay of the system alarm responses that allows a person to enter the building through the entry door to turn the system off. An alarm response begins if the area is not disarmed before Entry Delay expires.
<b>Error Tone</b>	The same warble tone as the Trouble tone, but not repeated.
<b>Exit Delay</b>	A programmed delay of the system alarm responses that allows a person to exit the area before the system turns on. An alarm response begins if a point is faulted after Exit Delay expires.
<b>Faulted Point</b>	A point that is not normal (for example, an open door or window).
<b>Fire Alarm Tone</b>	A warble tone that is on for 1 sec., then briefly off (repeatedly).
<b>Follower Point</b>	A point programmed to initiate an instant alarm unless a Delay point is faulted first. When a Delay point is faulted first, the Follower point assumes the Entry Delay time of the Delay point.
<b>Force Arming</b>	A method of overriding the safety feature that prevents arming with a faulted circuit on a control panel.
<b>Global</b>	Something that affects the entire system (for example, global point configuration refers to the programmable features that affect all points).
<b>Independent Zone Control</b>	A device that allows a single point or zone on a control panel to be armed or disarmed independently from the rest of the system.
<b>Instant Alarm</b>	A point type that initiates an alarm immediately when faulted. This point type does not follow any Entry/Exit Delay time.
<b>Invisible Point</b>	A point that does not display at any command center during alarm or trouble conditions.
<b>Keyfob</b>	A small, hand-held wireless device usually designed to fit on a key chain that consists of buttons that allow the user to perform various functions, depending on the keyfob, such as arming/disarming the system, operating outputs or sending reports.

## Glossary

<b>Keyswitch (Momentary)</b>	To operate a momentary keyswitch, insert the key, turn it, and then release it. The key returns to the starting position automatically. The key cannot be removed unless it is in the starting position.
<b>Keyswitch (Maintained)</b>	A maintained keyswitch typically has two positions marked “Armed” and “Disarmed.” To operate, insert the key, turn the key to the desired position, and remove the key.
<b>Latching</b>	The locking in of a circuit by means of a holding contact.
<b>Modem IIIa<sup>2</sup></b>	Modem IIIa <sup>2</sup> is a Bosch Security Systems reporting format (protocol) the D6412/D4412 uses to communicate to central station receivers. Even though you can program the panel to report in other formats, only Modem IIIa <sup>2</sup> reports are referenced in this document. If you choose an alternate reporting format, see the <i>D6412/D4412 Program Entry Guide</i> (P/N: 45351) to determine which report is substituted for the Modem IIIa <sup>2</sup> Report.
<b>Nibble</b>	Once the installer selects a value for a parameter, the panel stores the selection in E2 memory “Nibbles.” Each parameter uses one or more Nibbles. When programming from the command center, the installer enters a selection directly into the memory Nibbles. When programming from the remote programmer (RAM IV), the installer need only make one entry per parameter.
<b>No Delay</b>	Turning the system on without Entry or Exit Delay.
<b>Off</b>	The controlled points are not armed (system is off).
<b>Off Display</b>	The display that appears when the system is turned off and no keys have been pressed (normal display).
<b>Options</b>	Options are a unique type of parameter that allow the installer to configure up to four features by entering a value in a single Nibble.
<b>PSTN</b>	Public Switched Telephone Network. An assembly of communications facilities and central office equipment operated jointly by authorized common carriers that provides the general public with the ability to establish communications channels via discrete dialing codes.
<b>Parameter</b>	Each program parameter sets a specific value or chooses an option.
<b>Part On</b>	An installer-defined subset of the controlled points. Part On with No Delay (Instant) is an option. No Exit or Entry Delay is provided with the No Delay option.
<b>Part 2 On</b>	A user-defined subset of the controlled points. Part 2 On with No Delay (Instant) is an option. No Exit or Entry Delay is provided with the No Delay option.
<b>Points</b>	The panel reports changing conditions on the sensor loops it monitors as “point” events. For example, when the condition on On-board Sensor Loop 1 changes from normal (supervised, EOL resistor in place) to shorted, the panel can be programmed to create an alarm event for Point 1. That alarm event appears in command center displays as “Alarm, Pt 1.” If programmed for reporting, the panel would send an “Alarm, Pt 1” Report to the central station receiver in the Modem IIIa <sup>2</sup> format. Other reporting formats typically use “Zones” (Zn). in their reports instead of “Points.”
<b>Point Index</b>	Used to construct “personality types” for points used in the D6412/D4412 system. Each unique point index number determines responses to specific conditions occurring on the protected points.
<b>Point Type</b>	Describes what the point does (for example, fire point, burglary point, 24-hr. point, etc.).
<b>Point Scan Time</b>	The amount of time that passes while a point is electronically off-normal. This duration determines the length of a pulse.



---

<b>Programmable Outputs</b>	The D6412 provides up to 20 programmable outputs (D4412 provides up to 12). These outputs are activated by installer-selectable panel events. Event options include alarms, troubles, and scheduled events (Skeds). The panel's on-board outputs provide power or dry contact switching upon activation. When programmed to activate on alarm events, outputs are sometimes described as "bell." In some Modem IIIa <sup>2</sup> reports, outputs are described as "relay."
<b>Pulse Count</b>	A feature of an intrusion detection system in which an alarm is triggered only after there has been a series of detections in a short period of time. A pulse count is used in difficult environments where false alarms are a problem.
<b>RAM IV</b>	RAM (Remote Account Manager) IV is a Windows <sup>®</sup> -based account management and panel programming utility designed to remotely set up and program specific control panels.
<b>Remote Programming</b>	System programming by means of the system user's telephone line.
<b>Restoral Report</b>	A signal transmitted upon the removal of a trouble or alarm condition from an alarm circuit.
<b>SDI</b>	Serial Device Interface.
<b>Sked</b>	A scheduling parameter that allows a selected event to happen at a specific time.
<b>Trouble</b>	A service condition that needs to be corrected, such as a broken wire.
<b>Trouble Tone</b>	A warble tone that is on briefly, followed by a pause, followed by the warble tone (repeatedly).
<b>Visible Point</b>	A point that displays at command centers during alarm or trouble conditions.

Notes:

Index	D	I
<b>A</b>	D9528 Point Expander Module ..... 33	Installation ..... 15. 17
Alarm Power ..... 21	Address Programming ..... 37	Closing Installer Jumper ..... 16
Applications	Installation ..... 33	Installer Mode ..... 53
Compliance Guide ..... 65	Status LED ..... 38	Installer's Keypad ..... 53
Approvals ..... 65	Tamper Input ..... 36	Connector ..... 53
Approved Applications	D9529 OctoOutput ..... 41	Installer's Menu
Burglary ..... 65	Address Programming ..... 44	Battery Test ..... 54
Fire ..... 65	Configuration ..... 41	Bell Test ..... 54
Approved Applications Compliance Guide	Relay Outputs ..... 41	Keypad Program ..... 56
Burglary Applications ..... 65	Wiring ..... 42	Output Test ..... 55
Fire Applications ..... 65	D9533	Point Status ..... 54
Introduction ..... 65	Configuration Jumpers ..... 52	RF Menu ..... 55
Optional Compatible Equipment ..... 65	Installation ..... 50	Strobe Test ..... 54
Arming Devices ..... 45	Wiring ..... 51	Test Report ..... 54
Command Centers ..... 45	D9533 RS232 Serial Interface Module .. 50	Installer's Menu ..... 54
Keyswitch ..... 47	Device Stabilization ..... 17. 18	Installer's Passcode ..... 53
Auxiliary Power ..... 21	Dialing Format ..... 23	Introduction
Available Power ..... 21	Doubled Point Configuration ..... 29	Approved Applications Compliance
		Guide ..... 65
<b>B</b>	<b>E</b>	<b>K</b>
Battery ..... 19	Enclosures ..... 15	Keypad Program ..... 56
Charging ..... 17. 20	D8103 ..... 15	Keyswitch ..... 47
Float Charge ..... 20	D8108A ..... 15	Installation ..... 48
Installation ..... 19	D8109 ..... 15	Operation ..... 48
Recharge Cycle ..... 20	External Power Supply ..... 20	Programming ..... 47
Replacement ..... 19	<b>F</b>	Service Start ..... 54
Supervision ..... 19	FCC Notice ..... 9	Single Point Configuration ..... 28
Battery Test ..... 54	Part 15 ..... 9	Strobe Test ..... 54
Bell Test ..... 54	Part 68 ..... 9	System Status LED ..... 23
Burglary	Fire	<b>L</b>
Approved Applications ..... 65	Approved Applications ..... 65	Listing and Approvals
Listing and Approvals ..... 65	Listing and Approvals ..... 65	Burglary ..... 65
Burglary Applications	Fire Alarm Verification ..... 18	Fire ..... 65
Optional Compatible Equipment ..... 65	Fire Applications	Listings ..... 65
	Optional Compatible Equipment ..... 65	Listings and Approvals ..... 14
<b>C</b>	<b>G</b>	<b>O</b>
Called Party Disconnect ..... 24	Ground Start ..... 24	Off-Board Outputs ..... 41
Command Centers ..... 45		Off-Board Sensor Loops ..... 31
Address Assignment ..... 45		D9528 Point Expander Module ..... 33
Installation ..... 46		SDI Point Expanders ..... 31
Communication Failure ..... 24		On-Board Sensor Loops ..... 27
Compatible Equipment		Description ..... 27
Optional ..... 65		Doubled Point Configuration ..... 29
Compliance Guide		Sensor Loop Response Time ..... 29
Approved Applications ..... 65		Single Point Configuration ..... 28
Continuous Power Output ..... 21		Optional Compatible Equipment
		Approved Applications Compliance
		Guide ..... 65
		Output Programming ..... 22
		Output Test ..... 55

## P

Phone Cord Connection .....	23
Phone Line Fault .....	24
Point Status .....	54
Power .....	19
Alarm .....	21
Auxiliary .....	21
Available .....	21
Primary .....	19
Power Outputs .....	21
Alarm Power .....	21
Available Power .....	21
Continuous .....	21
Primary Power .....	19
Programming .....	13, 18
Outputs .....	22

## R

RAM IV Direct Connection .....	51
RF Menu .....	55
RS232 Serial Interface Module .....	50

## S

SDI Devices .....	49
D9533 .....	50
Installation .....	49
SDI Point Expanders .....	31
Sensor Loop Response Time .....	29
Service Reports .....	54
Service End .....	54

## T

Telephone .....	23
Called Party Disconnect .....	24
Communication Failure .....	24
Connections .....	23
Dialing Format .....	23
Ground Start .....	24
Line Fault .....	24
Location .....	23
Notification .....	23
Phone Cord Connection .....	23
Registration .....	23
System Status LED .....	23
Test Report .....	54
Testing .....	18
Battery Test .....	54
Bell Test .....	54
Strobe Test .....	54
Test Report .....	54

Windows® is either a registered trademark or trademark of Microsoft Corporation in the United States and/or other countries.