

COMPUTER CONTROLLED CODE MACHINES

ITL 9700
The Industrial Code Machine

- Recirculating bearings
- Superior rigidity and repeatable accuracy
- Supplied with carbide cutter
- 3 year parts and labor warranty (cutter not included)
- Communication port
- Over 600 depths and spaces built in
- 99 custom tables for new depths and spaces
- Compatible with majority of commercially available software
- Typical cut rates:

Laser mode	8 seconds
High Speed	9 seconds
Standard mode	15 seconds
Bi-Axial 6 pin	16 seconds



ITL9700A
w/Carbide Cutter
& Auto Rotate Head
14,990⁰⁰

ITL 9000
Industry Leader Since 1985

- Super bearing construction
- Repeatable accuracy (+/-) .001"
- Communication port
- Over 600 manufacturers' depths & spaces built in
- 99 custom tables for new depths & spaces
- 1 year parts and labor warranty (cutter not included)
- Cuts standard, Keymark® and Bi-Axial Medeco™
- One cutter emulates all flat widths



ITL9000
9,990⁰⁰
ITL9000CA
w/carbide cutter
10,590⁰⁰

ITL 950
The Most Cost Effective Code Machine Ever

- Both 12 volt and 120 volt usage
- Repeatable accuracy (+/-) .002"
- Communication port
- Over 600 manufacturers' depths and spaces built in
- 99 custom tables for new depths and spaces
- 1 year parts and labor warranty (cutter not included)
- One cutter does all (w/minor exceptions)



- ITL 950C**
Preloaded with automotive Codes
- Keymark® ready
 - Normal mode - Laser cut mode - Half cut mode
 - Medeco/Emhart™ head and program included
 - Inserts for double-sided automotive keys
 - Magnetic insert caddy

ITL950M
6,190⁰⁰
ITL950MCA
w/carbide cutter
6,790⁰⁰

IT950CM
6,790⁰⁰
ITL950CMCA
w/carbide cutter
7,390⁰⁰

ITL MMX
Compact, Affordable Yet Powerful

- Codes from major car manufacturers included
- Micro-stepping for precision
- Half-cut, Laser -cut and Normal Modes
- 600+ spaces and depths
- Plug into inverter for mobile use
- Updateable via USB Port
- Medeco™ Head
- Supplied with automotive cutter
- Compatible with majority of commercially available software
- Warranty: One year parts and labor (cutter not included)



TO BE USED WITH ANY XP NOTEBOOK, LAPTOP OR PC

Power: 120VAC & 12VDC standard
240VAC & 12VDC special order

Dimensions (LxWxH0): 12" x 11" x 7.5"

Net Weight: 36 lbs.

ITMMX
5,190⁰⁰

ITLMMX-CA
w/carbide cutter
5,790⁰⁰

www.acclock.com

ITL SIDEWINDER

Superb Features and Performance at an Affordable Price

STAND ALONE SIDEWINDER

Universal Jaw for North American high security car keys
Codes for major car manufacturers included
Micro-stepping for precision
Updateable via **USB** port
 For **mobile and shop** use
Bright LED Light as a work light
Warranty: One year parts and labor (cutter not included)

MACHINE SPECIFICATIONS
Repeatable accuracy of X-Y axis:
 +/- .0015" (.04mm)
Power: 120 volt AC, 240 volt AC (special order)
Keypad: Alpha-numeric Display: 4 lines
 20 characters per line
Dimensions: (LxWxH): 12" x 7.5" x 16"
 (305 x 191 x 407mm)
Net Weight: 32lbs (14.5Kg)
Gross Weight: 42lbs (19Kg)



ITLSW12C
7,800⁰⁰

COMPUTER-ASSISTED SIDEWINDER

Universal Jaw for North American high security car keys
Codes for major car manufacturers included
Micro-stepping for precision
Updateable via **USB** port
 For **mobile and shop** use
Bright LED Light as a work light
Warranty: One year parts and labor (cutter not included)

MACHINE SPECIFICATIONS
Repeatable accuracy of X-Y axis: +/- .0015" (.04mm)
Power: 120 volt AC (standard) 240 volt AC (special order)
Dimensions: (LxWxH): 12" x 7.5" x 16"
 (305 x 191 x 407mm)
Net Weight: 32lbs (14.5Kg)
Gross Weight: 42lbs (19Kg)



ITLSW12
7,000⁰⁰

Free with every unit
 • One year software update
 • Extra cutter

ELECTRONIC SAFE DIALER

Operates without supervision - set up and run until combination lock opens

Eliminates need for:
 - external computer
 - extra equipment
 - drilling

Wheels can be dialed:
 - to every possible safe lock combination
 - through a specific range of numbers
 Compact carrying case includes all tools required for the job

Warranty: One year parts and labor

MACHINE SPECIFICATIONS
Power: 120 volt AC .75 amp or 240 volt AC .5 amp 50/60 Hz
Keypad: Sealed Membrane Display: 2 lines
 16 characters per line
Dimensions: (LxWxH): 14" x 18" x 6"
 (355 x 457 x 152 [mm])
Net Weight: 15lbs (7kg)
Gross Weight: 16lbs (7.25kg)

Optional extras:
 - MA 20006 - adjustable mount plate kit
 - MA 01021 - jaw set for larger dials

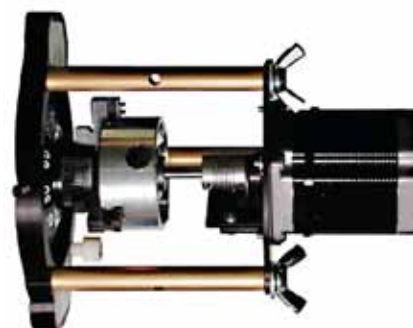

ITL2000
4,090⁰⁰

