

C300
HD
Installation Guide

Solid State Logic
S O U N D | | V I S I O N

C300
HD

Master Studio System

Installation Guide

Version 2.0.1

82S6PC3010B

Solid State Logic

S O U N D | | V I S I O N

Begbroke, Oxford, England, OX5 1RU • +44 (0)1865 842300

320 West 46th Street, 2nd Floor, New York, NY 10036, USA • +1 (1) 212 315 1111

Suite 401, 5757 Wilshire Blvd, Los Angeles, CA 90036, USA • +1 (1) 323 549 9090

3-55-14 Sendagaya, Shibuya-Ku, Tokyo 151-0051, Japan • +81 (0)3 5474 1144

7 bis, rue de la Victoire, le Blanc Mesnil, Paris 93150, France • +33 (0)1 48 67 84 85

Via Timavo 34, 20124 Milano, Italy • +39 (0)39 2328 094

Visit SSL at URL: <http://www.solid-state-logic.com>

© Solid State Logic

All Rights reserved under International and Pan-American Copyright Conventions

C100HD, C100HD-S, C200, C300HD, Centuri, C-SB StageBox, NetBridge,

Solid State Logic and **SSL** are trademarks of Solid State Logic

All other product names and trademarks are the property of their respective owners

No part of this publication may be reproduced in any form or
by any means, whether mechanical or electronic, without the
written permission of Solid State Logic, Oxford, England

As research and development is a continual process, Solid State Logic reserves the right
to change the features and specifications described herein without notice or obligation

E&OE

Contents

Section 1	Introduction	-	-	-	-	2
Section 2	Safety Considerations	-	-	-	-	3
	Safety Warnings	-	-	-	-	4
	CE/FCC/WEEE Certification and Directives	-	-	-	-	5
Section 3	Pre-Installation Information	-	-	-	-	6
	Services Provided by SSL	-	-	-	-	6
	Physical/Structural	-	-	-	-	7
	Console Footprint and Side Profile	-	-	-	-	8
	Centuri and Stagebox Side View	-	-	-	-	10
	Technical	-	-	-	-	11
Section 4	System Components	-	-	-	-	13
	Console Frame	-	-	-	-	13
	The Centuri Processor	-	-	-	-	15
	The Centuri Processor Cards	-	-	-	-	16
	C-SB Stagebox (<i>option</i>)	-	-	-	-	21
	NetBridge (<i>option</i>)	-	-	-	-	23
	KVM Switching	-	-	-	-	25
	Script Tray (<i>option</i>)	-	-	-	-	25
	Loudspeaker Shelf (<i>option</i>)	-	-	-	-	25
	TFT external input (<i>option</i>)	-	-	-	-	25
Section 5	Installation	-	-	-	-	27
	Power Connections	-	-	-	-	27
	Console Control	-	-	-	-	29
	Sync	-	-	-	-	29
	I/O – MicAmp Card	-	-	-	-	31
	I/O – Analogue Card	-	-	-	-	31
	I/O – Digital Card	-	-	-	-	33
	I/O – MADi Card	-	-	-	-	33
	GPI/O Card	-	-	-	-	35
	C-SB Stagebox Wiring	-	-	-	-	37
	Netbridge	-	-	-	-	39
	Talkback and Oscillator	-	-	-	-	41
	Phasescope and Meter Wiring	-	-	-	-	43
	DAW Midi interface	-	-	-	-	45
Appendices	A	Equipment Specifications	-	-	-	47
	B	Connector Details	-	-	-	51
	C	Connector Pinouts: Console	-	-	-	53
		Processor Crate	-	-	-	55
		NetBridge	-	-	-	61
	D	Audio Interfacing	-	-	-	63
	E	Environmental Specification	-	-	-	65
	F	Stagebox Installation Requirements	-	-	-	67
	G	Machine Control	-	-	-	68
	H	SSL Part Numbers by Description	-	-	-	71

Section I – Introduction

The object of this manual is to provide purchasers of the C300HD™ Console and Centuri™ Processor with information in the following areas:

- Safety considerations
- Installation requirements
- Items supplied: – Main components and optional items
- Installation: – Physical assembly
 - Electrical connections and cabling
 - System options
- Specifications and Physical dimensions
- Pinouts of standard connectors

The information provided by this manual is relevant to all of the versions of the C300HD.

The aspects of the C300HD which can be customised – frame size, channel layout, meter panel as examples – will be fully documented in the Custom Specification information for a specific console.

The Custom Specification information, which details the actual console as built, will be found in Section 10 of the console's Service Manual.

Section2 – Safety Considerations

This section contains definitions and warnings, and practical information to ensure a safe working environment. Please take time to read this section before undertaking any installation work.

Definitions

'Maintenance'

All maintenance must be carried out by fully trained personnel.

Note: it is advisable to observe suitable ESD precautions when maintaining electronic assemblies.

'Non-User Adjustments'

Adjustments or alterations to the equipment may affect the performance such that safety and/or international compliance standards may no longer be met. Any such adjustments must therefore only be carried out by fully trained personnel.

'Users'

This equipment is designed for use solely by engineers and competent operators skilled in the use of professional audio equipment.

'Environment'

This product is a class A product intended to form an integrated component part of a professional audio recording, mixing, TV, radio broadcast or similar studio wherein it will perform to specification providing that it is installed according to professional practice.

Electrical Safety Warning

When installing or servicing any item of SSL equipment with power applied, when cover panels are removed, HAZARDOUS CONDITIONS CAN EXIST.

These hazards include:

High voltages
High energy stored in capacitors
High currents available from DC power busses
Hot component surfaces.

Any metal jewellery (watches, bracelets, neck-chains and rings) that could inadvertently come into contact with uninsulated parts should always be removed before reaching inside powered equipment.

Installation Instructions

Voltage Selection and Fusing

Although the majority of SSL equipment uses auto-ranging power supplies, some sub-systems have user-selectable voltage inlets. Always confirm that the input mains voltage range is set correctly before applying power. Always isolate the mains supply before changing the input range setting.

If it is ever necessary to replace a blown mains-fuse, then always use the correct rating and type of replacement. If a correctly rated fuse continues to blow, then a fault exists and the cause should be investigated or the unit returned to SSL for repair/replacement as appropriate.

Details of mains settings and correct fuse ratings can be found in Appendix A of this manual.

Safety Earth Connection

Any mains powered item of SSL equipment that is supplied with a 3-core mains lead (whether connectorised or not) should always have the earth wire connected to the mains supply ground. This is the safety earth and grounds the exposed metal parts of the racks and cases and should not be removed for any reason.

Mains Supply and Phases

To ensure safe operation of this equipment, connect only to an ac. power source that contains a protective earthing (PE) conductor. This equipment is designed for connection to single phase supplies with the neutral conductor at earth potential – category TN or TT – and is fitted with a protective fuse in the live conductor only. This equipment is not designed for use with live and neutral connections reversed or where the neutral conductor is not at earth potential (IT supplies). This equipment should not be connected to a power system that switches open the return (neutral) lead when the return lead also functions as the protective earth (PE).

All mains powered assemblies must be connected to the same mains phase.

Mains cables will be coded with either of the following colour schemes:

	1	or	2
LIVE:	Brown		Black
NEUTRAL:	Blue		White
EARTH:	Yellow/Green		Green

Mains Isolation and Over-Current Protection

An external disconnect device (switch) is required for this equipment which must be installed according to current wiring regulations. A detachable power cord, if fitted to this equipment, is a suitable disconnect device; otherwise an approved disconnect switch is required – the rating of which is defined in the product specification (Appendix A) and on the equipment itself.

An external over-current protection device is required to protect the wiring to this equipment which must be installed according to the current wiring regulations. The fusing or breaking-current is defined in the product specification. In certain countries this function is supplied by use of a fused plug.

Some equipment (specifically units with PSU Redundancy) utilises multiple power sources. This is clearly marked on the equipment. The finished installation must also be clearly marked to ensure that all sources of power are removed before servicing begins.

Physical Safety

Most subsystems are too heavy for one person to lift. Take particular care when removing the computer chassis from the equipment rack.

If the console trim is removed for any reason then there may be sharp edges exposed on the frame metalwork.

CE Certification

CE The C300HD/Centuri system is CE compliant. Note that the majority of cables supplied with SSL equipment are fitted with ferrite rings at each end. This is to comply with the current regulations and these ferrites should not be removed.

If any of the console metalwork is modified in any way – particularly the addition of holes for custom switches etc. – this may adversely affect the CE certification status of the product.

FCC Certification

FC The equipment which forms a C300HD/Centuri system has been tested and found to comply with the limits for a Class A digital device, pursuant to part 15 of the FCC Rules. These limits are designed to provide reasonable protection against harmful interference when the equipment is operated in a commercial environment.

This equipment generates, uses and can radiate radio frequency energy and, if not installed and used in accordance with the instruction manual, may cause harmful interference to radio communications. Operation of this equipment in a residential area is likely to cause harmful interference in which case the user will be required to correct the interference at his own expense.

Instructions for Disposal of WEEE by Users in the European Union



The symbol shown here, which is on the product or on its packaging, indicates that this product must not be disposed of with other waste. Instead, it is the user's responsibility to dispose of their waste equipment by handing it over to a designated collection point for recycling of waste electrical and electronic equipment. The separate collection and recycling of your waste equipment at the time of disposal will help to conserve natural resources and ensure that it is recycled in a manner that protects human health and the environment. For more information about where you can drop off your waste equipment for recycling, please contact your local city office, your household waste disposal service or where you purchased the product.



Section 3 – Pre Installation Information

Physical installation of the console is normally carried out by a specialised transportation company. In some cases this will have been arranged by the local SSL office, in other cases by the facility.

The cables that run between console and processor can be shipped in advance of the console in a separate kit (the pre-install kit). These cables should be installed by the facility engineers. Instructions for installing these cables are found on pages 26 to 31 of this manual.

Refer to Appendix A for weights and power consumption information.

Before the console is installed all building work should be completed and the environment **MUST** be clean otherwise the warranty will be rendered invalid.

Before commissioning can take place the following must be completed:

- Air Conditioning installed, tested, blown-through and working
- Lighting installed and tested
- Cable Trunking installed
- Wall and floor finishes completed
- Power Distribution installed and tested
- Cables installed and tested
- Monitor loudspeakers installed and working
- Other utilities (telephone, water etc.) available

Services provided by SSL

Commissioning

All C300HD systems include on-site commissioning by an SSL engineer. This is usually expected to take from 2 to 4 days depending on system size, configuration and options. Large systems, or consoles split for shipment, may require an additional 1–2 days of commissioning time.

You will be contacted by your local SSL office or agent shortly before delivery to arrange a commissioning date.

Training

Three days of standard operator training are provided with each C300HD system. If required, this is scheduled to take place immediately following the commissioning period and is usually carried out by the commissioning engineer. A further day of advanced operator training is available at additional cost.

On-site maintenance training is also available at additional cost. This can be either one day for a basic overview or two days for more advanced training.

Training should be requested at time of order. For all training, we recommend that no more than five persons attend each session. If the use of an interpreter is necessary the training period may need to be extended (at additional cost). Note that travel and subsistence costs are not normally included. Please contact SSL's training department at: support@solid-state-logic.com.

Warranty

All systems normally include 13 months warranty from date of shipment. This does not include consumable items such as magnetic media, disks etc. Further details may be found in SSL's Conditions of Trading (printed on the reverse of all SSL invoices).

Physical Requirements

Console Control Surface

The console control surface can be specified to have from 16 to 96 physical channels so the size and weight will vary considerably. A dimensioned footprint drawing for each specific console control surface can be provided by SSL's Project Engineering Department. See page 46 for an example of a 32-channel footprint.

Consoles can be built with split points at any profile. The console can then be split for shipment to simplify installation into client's premises. Reassembly will be by SSL engineers.

Cable sets are available in 10, 16, 25, 48 and 80m standard lengths.

Cables for the connection of ancillary functions: meters, talkback or any custom switching etc. are not supplied by SSL and will need to be provided by the facility. See pages 47–49 for wiring information.

Refer to Appendix A for weight and power consumption information.

Rack Mounting Equipment – Centuri, NetBridge and Stageboxes

The Centuri Processor is a 15U height chassis into which a range of I/O cards can be fitted. The system's processing and DSP resource is also housed in the Centuri rack. The Centuri is therefore fitted with cooling fans and is expected to be housed in a separate 'machine' room.

A 19" equipment rack will need to be provided into which the Centuri Processor can be mounted. Note when positioning the rack that cards are inserted into the Centuri Processor from both the front and the rear depending on function. Clearance for access to cards must therefore be provided both in front of and behind the rack (see page 10 for service clearance diagram).

A MIDI interface is supplied as standard on the C300HD. Access to the MIDI connectors is via a separate 1U breakout panel which connects to the rear of the Centuri rack. A standard 800mm deep equipment rack will have sufficient room for the panel to be located directly behind the Centuri. If shorter racks are used then an additional 1U of rack space must be allocated for the panel. See page 45 for additional information.

NetBridge – which is an option – is a 2U high rack mounting unit.

Remotely located stageboxes (C-SBs) – which are also optional – may be specified. These are 14U rack units.

Centuri, NetBridge and stagebox units MUST be supported on shelves and not only by the rack ears.

Acoustic Isolation

Because of the noise generated by cooling fans the Centuri core should be located in a separate machine room. Adequate noise isolation should exist between the machine room and control room/recording areas.

Noise figures for individual units are given in Appendix A.

Connector Panels and Power Supplies

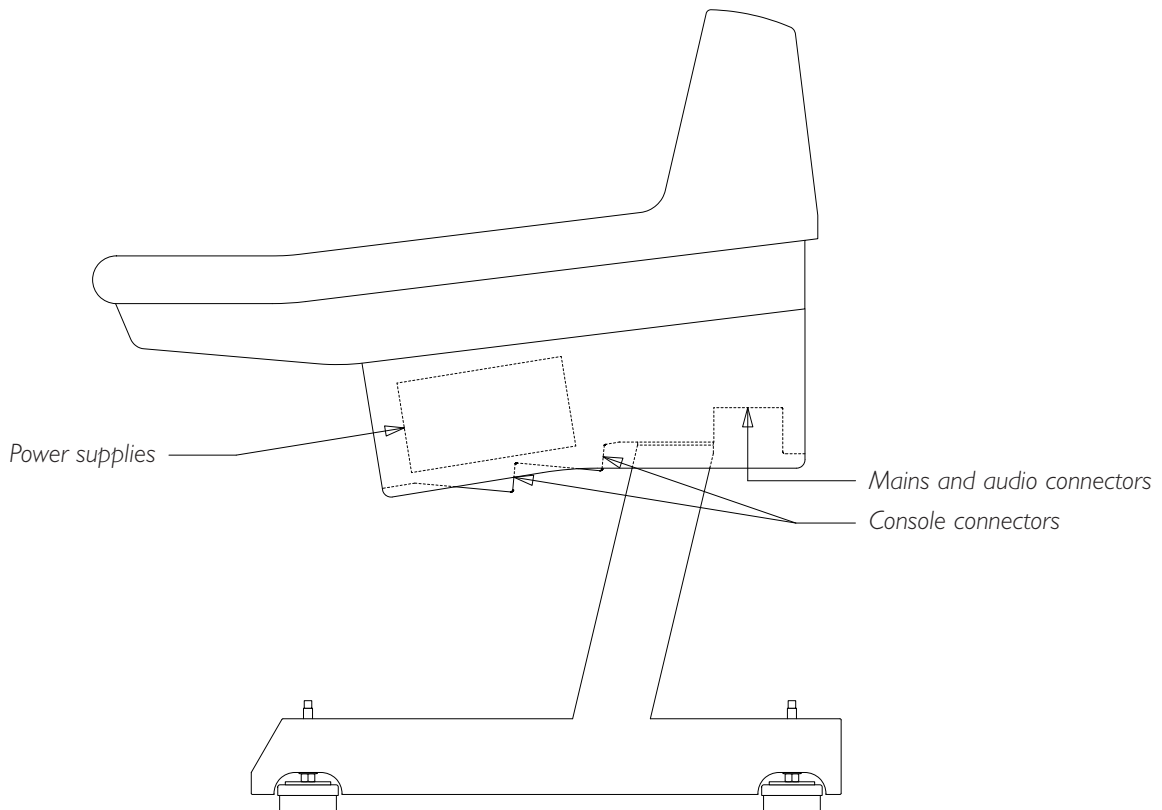
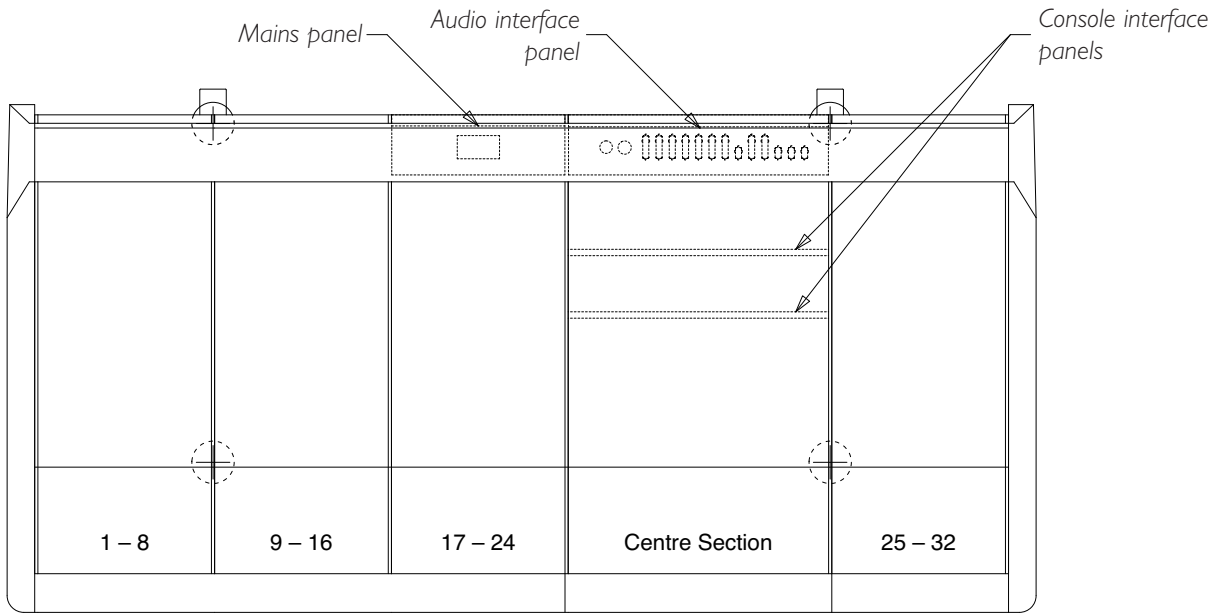

Air Conditioning Requirements

Air conditioning will almost certainly be required for both the Machine and Control rooms in order to maintain the temperature and humidity to within the required levels.

Power dissipation figures for console control surface and equipment rack are listed in Appendix A.

Appendix E contains the environmental specification for SSL equipment.

Cable Ducting

Cable ducting will be required between the console and the Machine room (as well as to any outboard racks and the recording areas). The ducting provided should be of sufficient size such that approximately 50mm x 35mm is available for console surface connection. It is not possible to route cables down through the console legs.

The connectors for all control and interface cables are located beneath the console's Centre Section. The connector panels are orientated so that cables will route towards the rear of the desk.

The connectors for ancillary functions, such as talkback and metering etc., are located on a panel at the rear of the Centre Section.

The mains input power connector will be located on a separate panel. This panel is usually positioned in a bay adjacent to the Centre Section nearest to the centre of the console but may vary due to console layout.

Service Access

Access to all major electronic assemblies within the frame is either from the front or from beneath the console. The meter LCD panels are retained by finger-screw fastener beneath the top trim. The top trim is designed to hinge upwards to allow access to these screws. If the console is being built into restricted space – as in some mobile installations – then always allow a minimum of 80mm clearance above the top trim.

Sufficient clearance must be provided in front of and behind the rack into which the Centuri processor is installed so that cards can easily be removed. See the drawing on page 10 for minimum clearances.

Centuri Processor Crate (side view) Showing Card Access

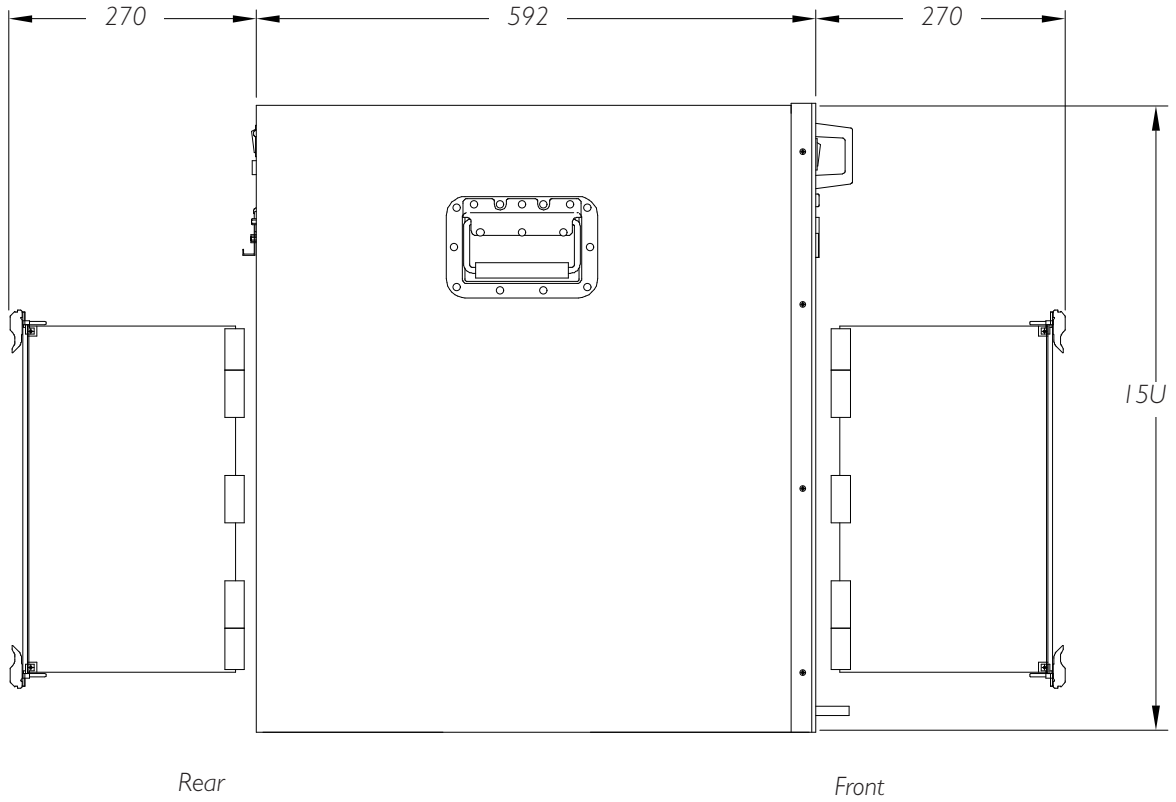

C-SB Crate (side view) Showing Card Access

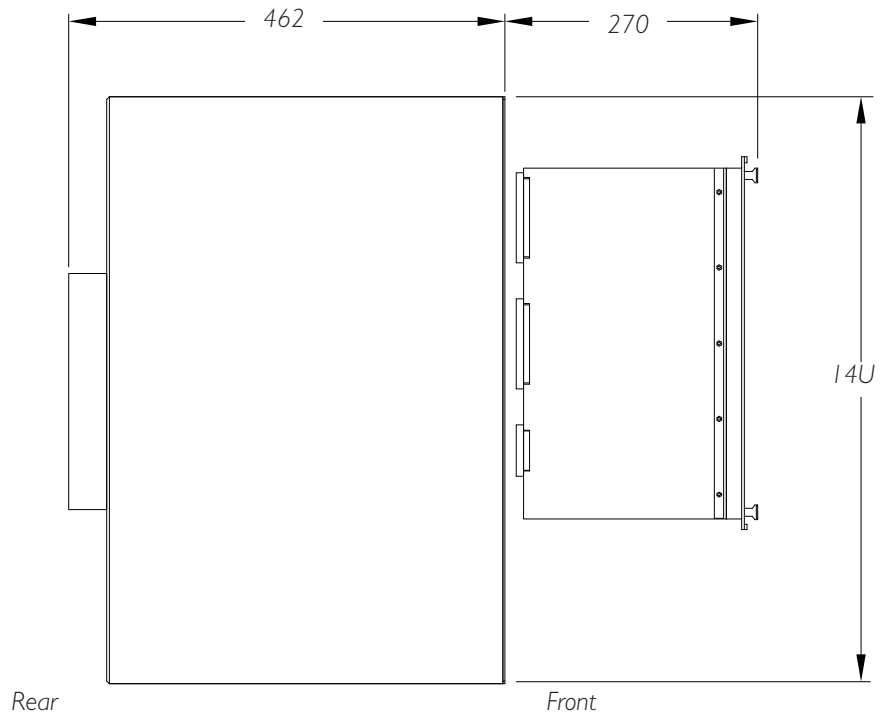

Dimensions in mm

Technical Requirements

System Synchronisation

The Centuri Processor requires an external Video Reference Signal to derive various system control and digital audio timing clocks. Both SD (Standard Definition) and HD (High Definition) sync signals are supported provided they comply with the following requirements:

Suitable SD sync signals are a standard black-and-burst (75 Ω 1 volt pk-pk) signal at either PAL (625 line 50Hz) or NTSC (525 line, 59.94Hz) frame rates.

The following HD Tri Level sync signals can be used as a valid system reference:

1080i	–	60/59.94/50 Hz
1080p	–	30/29.97/25/24/23.98 Hz
1080PsF	–	24/23.98 Hz
720p	–	60/59.94/50 Hz

As standard, C300HD supports both the 48kHz Professional sampling frequency (Fs) and a 96kHz (2Fs) sample rate. A Variable Sample Rate (VSR) option card adds support for 44.1kHz and 88.2kHz sample rates as well as pull-up/pull-down multipliers to provide the various additional sampling frequencies that may be required when working with Film and TV post production in NTSC and HD formats.

Power Connections – Mains Input Voltage & Current

Both the console control surface and the Centuri processor rack are fitted with auto-sensing power supplies and will function at any voltage from 100 to 240 volts without adjustment.

The console is supplied with one or more detachable mains leads. These leads are 2m in length and the cable diameter is 11mm. The free end of these leads is unterminated for connection to a suitable outlet.

The inrush current present when powering the console can be significant – typically ten times the steady current – so the use of ‘slow’ or ‘motor’ rated fuses/circuit-breakers is recommended.

Both the Centuri processor rack and the console control surface can be fitted with backup power supplies for PSU redundancy during live transmissions work. The backup supply works independently from the main supply and the console will be equipped with two mains input leads. For additional security it is recommended that one of the power sources should be from an un-interruptable source.

NetBridge (which is a separate 2U unit – see page 23) is fitted with a voltage select switch for 230V or 115V operation. Confirm that the voltage is correctly set before applying power – see page 23.

See Appendix A for equipment specifications.

Grounding

A standard system should not require any additional grounding over and above that supplied by a correctly installed mains supply. All rack unit chassis are permanently bonded to mains earth. A permanent mains earth connection via the mains inlet must be provided.

If, due to the quality of the mains wiring within an installation, it is deemed necessary to improve upon the mains earthing, chassis ground connection points are provided as follows:

Centuri rack chassis ground can be accessed via a stud located on the rear panel.

Console chassis ground can be accessed via a stud located on the mains power connector panel.

All audio connectors, both analogue and digital, have their screen pins connected directly to the chassis at the point of entry to comply with AES/EBU grounding and EMC standards.

C300HD Channel Bay Layout

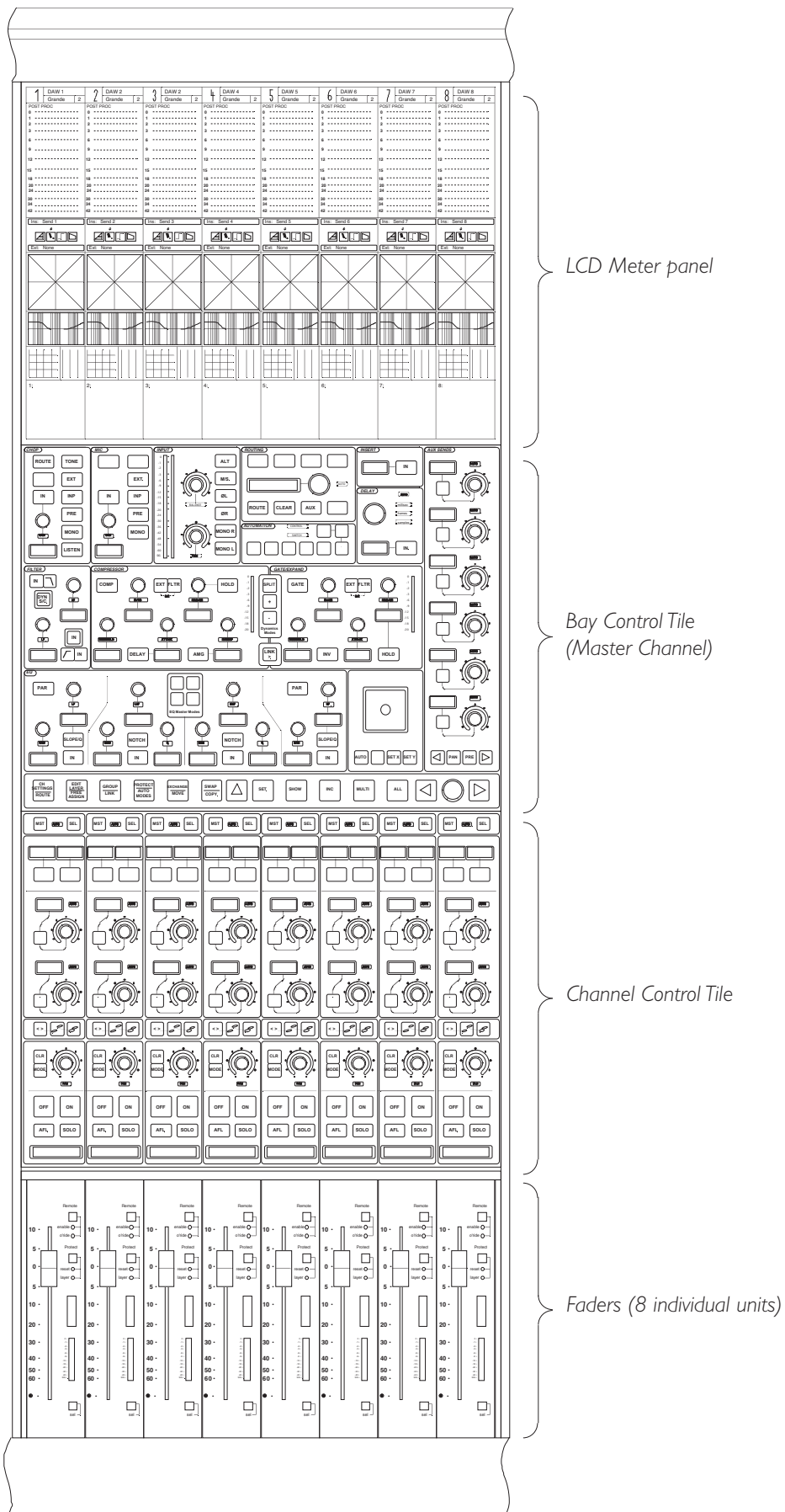

Section 4 – System Components

This section gives an overview of the main units in the system. See Appendix A for specifications and Appendices B and C for connector details and pinouts.

C300HD Console

Each console control surface will consist of one, two or three Master Sections and can be specified to have from 16 to 96 channel faders in groups of 8. (Note: a group of 8 faders and controls and its frame is termed a *bay*). See Appendix A page 50 for frame sizes.

Each console channel-bay consists of four sections: Faders, Channel Control, Master Channel and the meters. As a minimum, it is only necessary to have one Master Channel tile fitted to a console as this can be used to access any processing channel within the frame, although, for convenience and additional flexibility, additional Channel Masters may be fitted to any bay.

The number of physical faders fitted does not limit the number of processing channels available; this is determined solely by the amount of DSP resource fitted to the processor.

Each Master Section may optionally be specified with a 6 or 8-channel LCD phase-scope and has additional space for mechanical VU meters – a 6 off (5.1) VU meter panel is available to order as a standard option. Alternatively, a range of custom meter configurations is possible; these should be detailed at the time of order. The standard phasescope types available are the RTW 10830 or the DK Audio MSD600C.

The console frame may be specified to have 19” wide sections for script space (known as ‘Producer’s’ tables). These can be fitted with either a full-depth flat table or a shorter table and 7U of equipment racking. Note that there is limited depth in the Producer’s section for outboard units. Refer to appendix G for the available depth information.

The console is not fitted with dual redundant power supplies as standard. A backup power supply system is available to order as an option.

SSL's Project Engineering Department are able to provide CAD footprint drawings of proposed console layouts during the specification process.

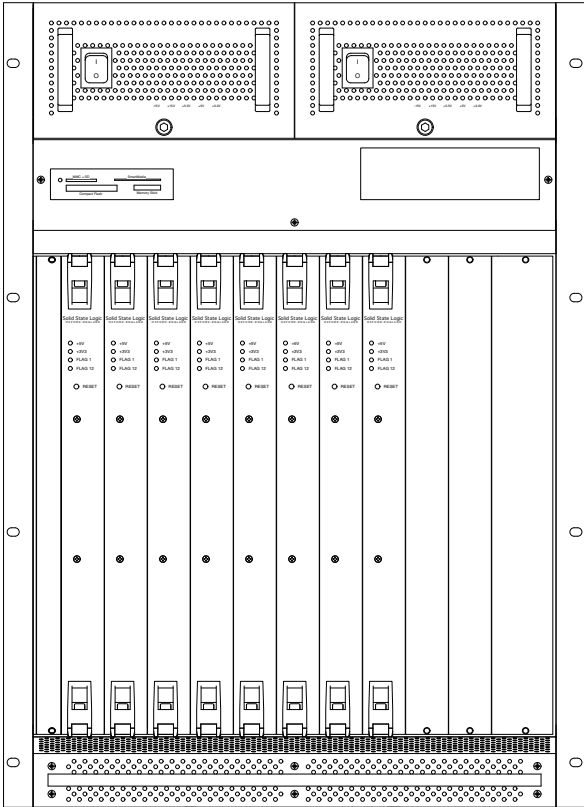

Centuri Processor Crate (Front View)

Access to:

- PSUs
- Removable media drive
- DSP cards
- I/O Cards (Mic or Digital*)

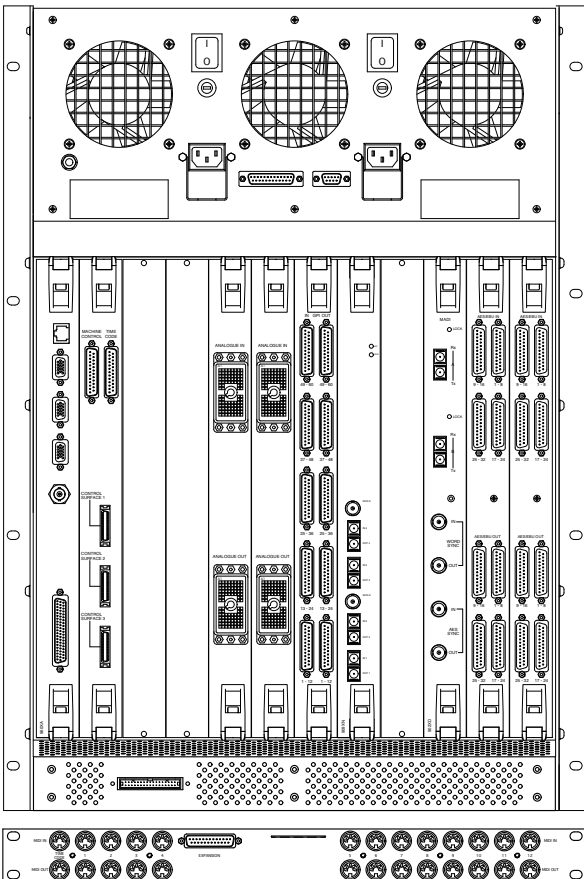

Centuri Processor Crate (Rear View)

Access to:

- CPU card
- Console interface card
- GPI/O card
- Routing/Link card (fitted with 2 Fibre Link ports)
- I/O Cards (Analogue, Digital or Mic*)
- DAW Midi interface panel

*special order only

NB. Cards shown are an example. Configuration will vary according to specification.

The Centuri Processor

The Centuri processor is a 15U high 592mm deep rack unit. Cards are fitted to the front and rear of the chassis so space for access is essential. See page 10 for chassis dimensions and minimum service clearance.

At the front of the processor are located the plug-in PSU units. One unit is capable of powering the system and a second module may be ordered to provide power redundancy.

The panel below the power supplies is fitted with the Compact Flash memory card reader. This is used to transfer system software onto the internal hard disk. Note that although a multiformat card reader is fitted, only the Compact Flash card format is currently supported. The system's hard-drive is located behind this panel. A second, redundant hard-drive can be specified as an option. If this feature is ordered, a second identical drive, which also contains the system software, is fitted and a front panel key switch is provided for disk selection.

Below the drives is the front card-cage which has space for 11 plug-in cards, numbered from left to right. The cards are arranged as follows:

Slots 1–4	Channel DSP cards.
Slot 5	Always fitted with a master DSP card for mix processing.
Slot 6	Optional 2nd master DSP card for enhanced 2Fs bus capacity and processing.
Slots 7–10	Can be a combination of additional DSP cards and/or micamp cards (digital or MADI cards to special order only)†.
Slot 11	Always blank.

There rear of the processor has space for 12 plug-in cards. Note that these slots are numbered from right to left.

Slots 1–4	Available for I/O cards (analogue, digital and MADI).
Slot 5	Always fitted with the console's Routing/Link card.
Slot 6	Reserved for the optional GPI/O card.
Slots 7–10	I/O cards – analogue, digital and MADI (mic cards to special order only)†.
Slot 11	Always fitted with the Console-Interface card.
Slot 12	Always fitted with the CPU card.

Note that front and rear mounting I/O cards, although functionally identical, are physically different so it is not possible to exchange cards between back and front.

At the rear of the rack is the connector for the DAW interface panel. When the DAW control option is specified a separate 1U Midi breakout panel and connecting lead is provided. See page 45 for additional information.

† Specifying rear mounted micamp cards or front mounted digital/MADI cards will extend the order lead time.



DSP Card

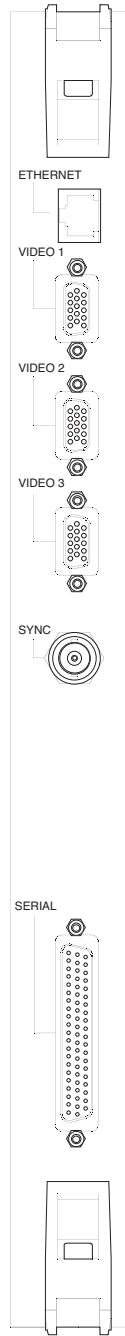

CPU Card

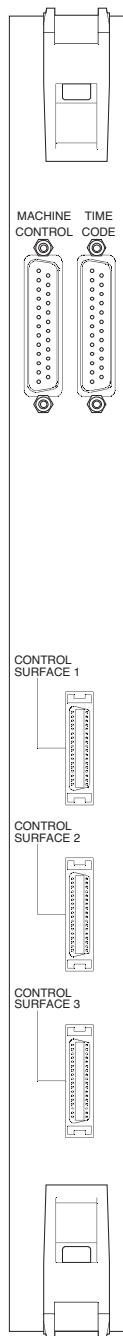

Console Interface Card

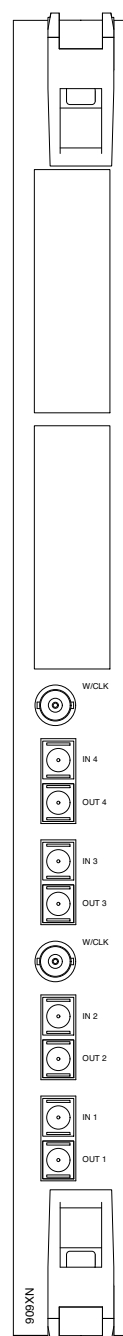

Routing/Link Card
Shown equipped with two Madi fibre ports



Microphone Input Card

Centuri – DSP Card

The DSP cards supply the signal processing function for the Centuri system. Each card provides 32 channels of processing at 48kHz. or 16 channels of processing at 96kHz. DSP cards are all the same and do not require configuration. They can therefore be fitted into any of the appropriate slots in the front of the Centuri rack.

Centuri – CPU Card

The Centuri Processor is always equipped with a CPU card. It can only be fitted to the left-most rear slot.

The CPU card is fitted with connectors for access to the following functions:

'Ethernet'	100baseT console network ⁽¹⁾
'Video 1'	Display output for the Centre Section monitor (Video 2 and 3 are unused).
'Sync'	Video sync input.
'Serial'	62-pin connector providing eight RS422/RS232 serial ports. An adaptor cable breaking out to eight off 9-way D-type male connectors, labelled 'TTY-A' to 'TTY-G', is provided.
	TTY-A, B, C, D and H: - machine control 1–5 (RS422)
	TTY-E: - Console (RS232) – Connection for data terminal
	TTY-F and G - Unused on C300

⁽¹⁾ The Ethernet connection is used for SSL control information, it is not TCP/IP protocol. Do not combine with proprietary networks. Standard Ethernet repeaters can be used.

Centuri – Console Interface Card

The Centuri Processor is always fitted with one Interface card. It must be fitted to the rear of the card-cage next to the CPU card.

The card provides the connection to the console's control surface and handles all switch and lamp signals. Of the three 'Control Surface' connectors, only numbers 1 and 2 are used as these contain sufficient capacity for the largest C300HD console.

This card also provides the connectors for parallel machine control and analogue timecode.

Centuri – Routing/Link Card

The Centuri is always fitted with a Routing/Link card. It must be fitted to the rear card-cage in position 5.

This card has two functions. The first is an internal function to manage the audio routing across the system's backplane. The second is to provide an interface for up to four optional MADI fibre ports. These ports provide access to remote SSL Stageboxes or can be used as synchronous MADI I/O ports. Each port is equipped with a main and a redundant duplex fibre connection. Links default to 64/32 Channel mode with 96K framing at 2Fs. Internal links on each card can be set to force 56/28 channels or Legacy (48K) framing at 2Fs. In addition, each fibre interface provides an output of system Word Clock on a separate BNC connector.

The audio Madi ports are available in either multimode or singlemode versions. A multimode version can be used for cable lengths of up to 550m and the singlemode version for up to 2km. Fibre cables are not provided.

The fibre interface cards are cost options and should be specified at the time of order.

Centuri – Micamp Card

The Microphone input card (generally known as the BMA or 'Broadcast Mic Amp') provides 12 input channels. The input is via a female Varicon (EDAC) connector. Mating connectors can be supplied as a cost option.

Each of the mic inputs has a buffered split output. The buffering takes place after the input pad, the RFI filter and the 25KHz low-pass filter but before the variable gain stage. The split output has a gain of 26dB above the mic input level (or 6dB with the pad in circuit) but is unaffected by the consoles' mic gain setting. The split outputs are available on two female 25-way D-type connectors.

Micamp cards are normally fitted to the front of the Centuri. If more than 48 channels are required then rear mounting cards can be specified as a special order. Refer to section C for connector pinouts.



Analogue I/O Card

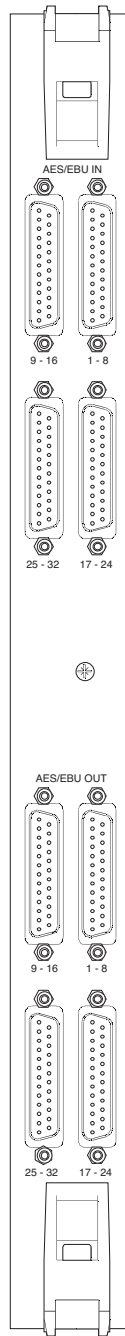

Digital I/O Card

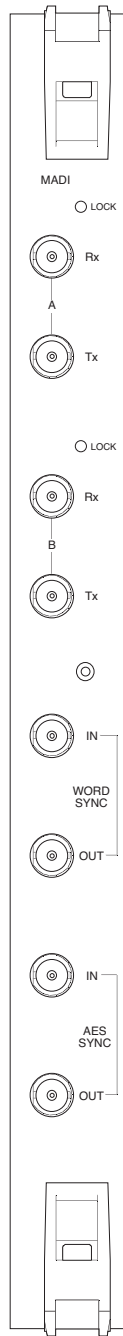

MADI I/O Card
Copper version

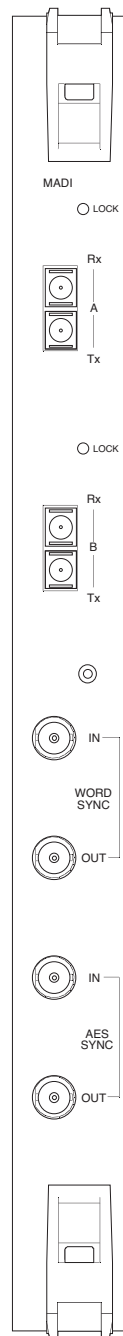

MADI I/O Card
Fibre version

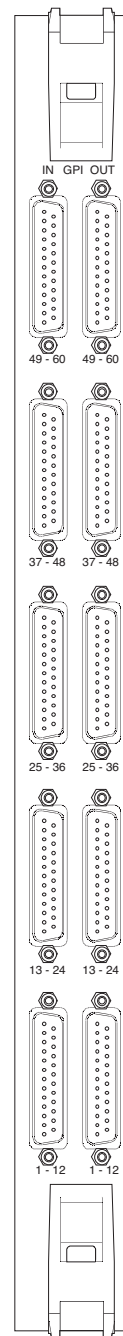

GPI I/O Card

Centuri – Analogue I/O Card

The Analogue card provides 24 channels of balanced line-level input and output. At least one Analogue card will need to be included to feed the monitor speakers as the post monitor-pot signals are only assignable to analogue outputs. The connectors used are Canon DL96 types. Mating connector kits and a contact crimp tool can be supplied (as cost options).

Analogue cards are fitted at the rear of the Centuri chassis.

See page 57 for the DL pinout.

Centuri – Digital I/O Card

The Digital I/O card is available in two versions: 110Ω and 75Ω. Both types provide 64 channels (32 AES/EBU pairs) of digital input and output. The 110Ω card is equipped with balanced input and outputs whereas the 75Ω card is unbalanced for correct matching to coaxial cables. A breakout panel is available as an option for the 75Ω card – this converts D-25 connectors to chassis BNC plugs and comes with 1m connecting looms. These panels should be mounted behind the Centuri rack; they cannot be remotely located because the linking cables are unbalanced.

Sample rate conversion is available on every input so the card can accept input rates from 32kHz to 96kHz. Sample Rate Conversion is also available on all outputs, either at any of the available System sample rates (Fs or 2Fs) or locked to a nominated AES input on the same card. If the VSR option is fitted (see page 11), any AES input can be selected as the System sample clock. The connectors are all D-25 type females and mating connectors can be supplied.

Digital cards are fitted at the rear of the Centuri chassis.

Centuri – Madi Card (Copper version)

The MADI I/O card can be configured to operate in 56/64 channel mode at Fs or in 28/32 channel mode at 2Fs. Both Legacy (Fs) Framing* and Standard (2Fs) framing modes are available at 2Fs sample rates. The 56/28 channel mode supports Fs ±12.5% varispeed operation. The 64/32 Channel mode will accept ±0.1% variations in sample frequency.

**Only synchronous 2Fs MADI signals with legacy framing are supported and any Word Clock or AES sync signal must be disconnected from the MADI card or the audio will be muted.*

Both Word Clock and unbalanced AES-3id sync inputs and outputs are provided. If the incoming MADI signal is synchronous (i.e. derived from a device locked to the same reference as the C300HD processor core), then no external sync signal is required. If, however, a valid Word Clock or AES sync signal is connected, the card will automatically default to using the external sync reference to decode the MADI data stream. The Sync output signal always follows the current MADI sync reference source and can be used to clock any connected device that requires a MADI/AES sync reference.

The MADI card includes input and output sample rate conversion which offers the same functionality as the Digital I/O card except that the Word Clock input is used as the reference for Output sample rate conversion and is also required if sample rate conversion is to be used on the MADI input.

The card is fitted with dual connections – MADI A and MADI B. The outputs are duplicates of the MADI signal so that a safety backup can be made without having to use external distribution. For the inputs, MADI A has priority but MADI B will become active if the A signal is lost. Refer to page 33 for further interfacing details.

Centuri – Madi Card (Fibre version)

Operates in exactly the same way as the copper version but the MADI connectors are now singlemode or multimode SC optical types. The fibre type must be specified at time of order.

Centuri – GPI/O Card

The optional GPI/O card provides 60 GPI inputs and outputs. Inputs (which can trigger many console functions including channel faders and cuts) are opto-isolated. The outputs are provided by relay closure. Access is via 25-pin D-type connectors; inputs are male and outputs are female.

Only one GPI/O card can be fitted to the Centuri rack.

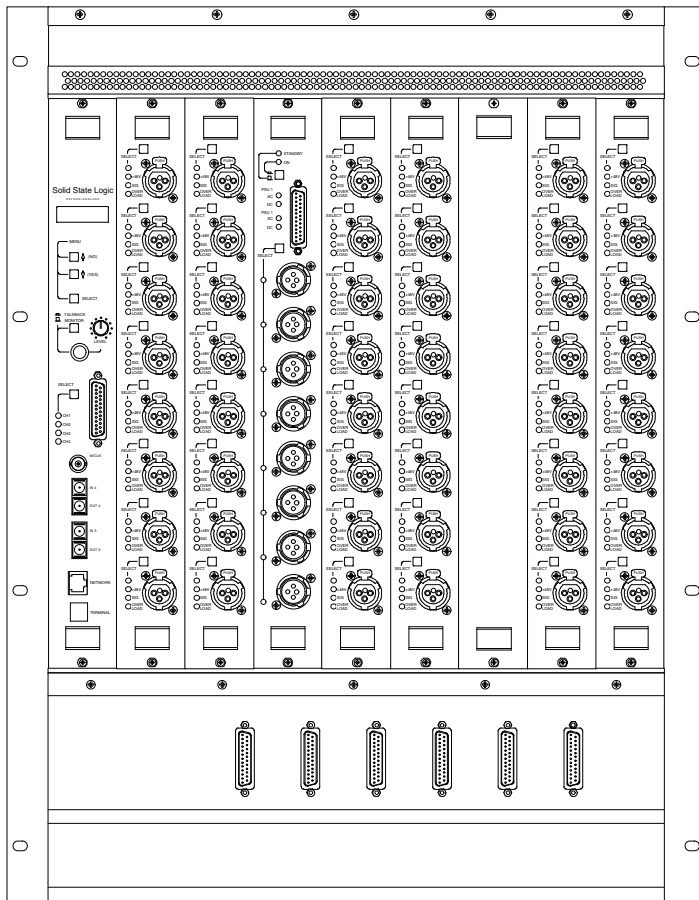

C-SB Stagebox
(Front View)

- 48 inputs
- 48 Split outputs
- 16 Line outputs
- 4 GPI I/O
- Single or dual Fibre Link

C-SB Stagebox (option)

The C-SB is a Mic/Line input/output stagebox which can be located remotely from the Centuri chassis. The C-SB can operate at all C300HD sample rates but is currently restricted to 32 channels when operating at 2Fs. Each CS-B is a 14U high, 462mm deep, rack-mounted unit.

At the front of the rack are nine slots for plug-in cards: six slots for mic/line input cards; two slots for line output cards and one for the CPU card. At the rear is an auto-ranging switch-mode power supply. This will accept input voltages from 100–240v without adjustment. The PSU units provide two unswitched mains outlets via IEC 6A shuttered sockets. A 2nd power supply unit may be fitted to provide redundancy

Each micamp input card is equipped with 8 channels, therefore a C-SB rack may be fitted with from 8 to 48 mic inputs. The line output card also provides 8 channels and in addition features 4 channels of GPI relay closure. The CPU card is fitted with a headphone socket to allow local monitoring of sources and also provides four analogue outputs via a 25-way D-type connector. These outputs are assigned from the console and may be used for additional analogue feeds such as talkback or SLS.

Each mic input is provided with a split output. This output functions in the same way as the BMA circuit. (ie. post pad, limiter and 26dB buffer but pre the variable gain stage). The split outputs are available on 25-way D-type male connectors.

Remote stageboxes are connected to the Centuri core by using duplex fibre-optic cable⁽¹⁾ for the Madi audio data (referred to as a GLink in the software) and a separate Ethernet cable⁽²⁾ for the control functions (gain, pad, filter etc.). The audio fibre links to a stagebox can be duplicated thus creating audio redundancy for critical or on-air reliability. The number of Madi links required for the Centuri rack should be specified at the time of order.

The standard unit is fanless and so can be located within the live production area – subject to the following note. A low-noise fan ventilation kit is available as an option.

The stagebox racks are cooled by convection at the front of the rack. The air flow from bottom to top of the front panel must not be obstructed in any way (cable guides are provided at each side to route cables away from the air intake). The air temperature at the intake and at the rear PSU heatsinks MUST NOT exceed 30° Centigrade.

Special considerations need to be observed when fitting stageboxes into flight cases – refer to Appendix F.

- (1) The fibre optic cable is available in two types: for distances of up to 550m (multimode fibre) and distances of up to 2Km (singlemode fibre).
- (2) The standard maximum limit for Ethernet cable is 100m. For distances of over 100m Ethernet repeaters may be needed. Alternatively, the Ethernet cable can be converted to fibre. This can then run the same distances as the audio fibre. Please discuss specific requirements with SSL's Project Engineering Department.

NetBridge (Front View)

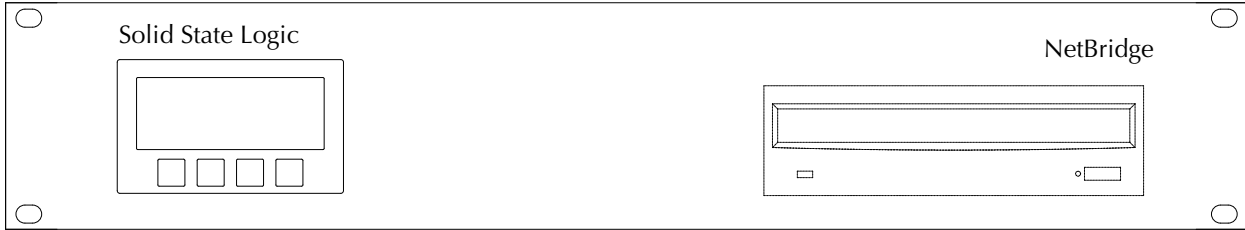

NetBridge (Rear View)

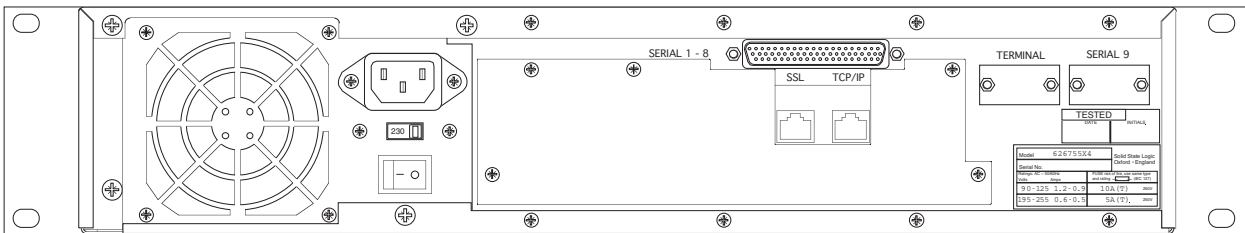

NetBridge - PSU Voltage Selection

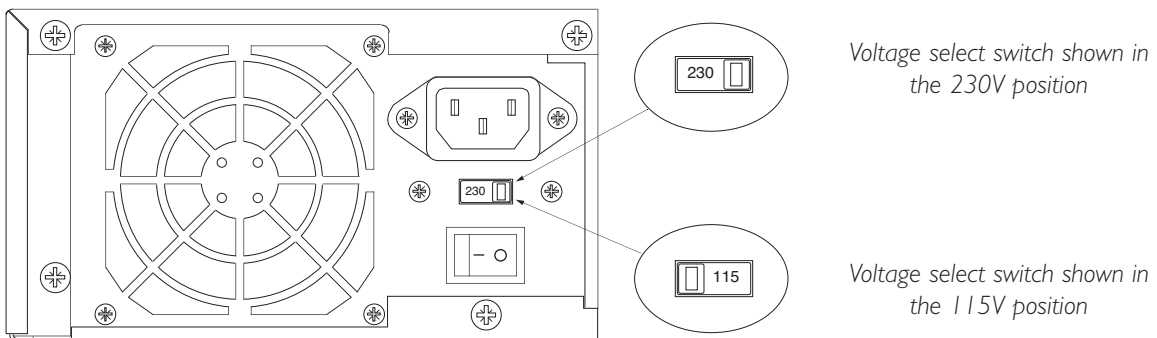

NetBridge (option)

NetBridge is a 2U rack mounting unit.

The NetBridge provides two main features. Firstly (as the name suggests) it is a bridge between the proprietary Solid State Logic network, and the standard TCP/IP protocol, allowing remote diagnostic connection over the Internet. Up to 7 diagnostic ports may be served by a single NetBridge unit, with secure log-in facilities enabling trained staff or SSL engineers to access diagnostic functions remotely from any location worldwide.

Do not combine the SSL network and the facility's TCP/IP network; they are different protocols.

Secondly it can be used to transfer data files between the C300HD console to which it is dedicated and the 'SSL-Network' central file server (CFS). This allows C300HD session templates (used for offline configuration) and project archives to be moved across the Internet without requiring access to the console's CPU.

Using the secure login access provided by NetBridge, users may upload a console template to a secure website, edit the configuration offline and then reload their profile prior to the production saving valuable setup time. Parameters available for offline configuration include fader strip allocations, channel names and type, bus routing assignments, processing order, output options and fader grouping setup.

NetBridge requires access to the facility's internet service. To do this, an Ethernet connection will be required. The NetBridge will also need permission to access the SSL Network secure server; this may require the configuration of any firewall software that may be in use. (See page 39 for further information.)

NetBridge does not have dual power supplies as it is not critical to console operation.

NetBridge is not fitted with an auto-ranging power supply and the input setting must be confirmed before applying power. The voltage select switch is located on the rear of the PSU unit, see opposite for switch location.

To change the setting:

- 1. Switch off and remove the IEC lead.*
- 2. Using a small flat-bladed screwdriver, slide the select switch so that the appropriate voltage is indicated.*

Location of Console Connectors

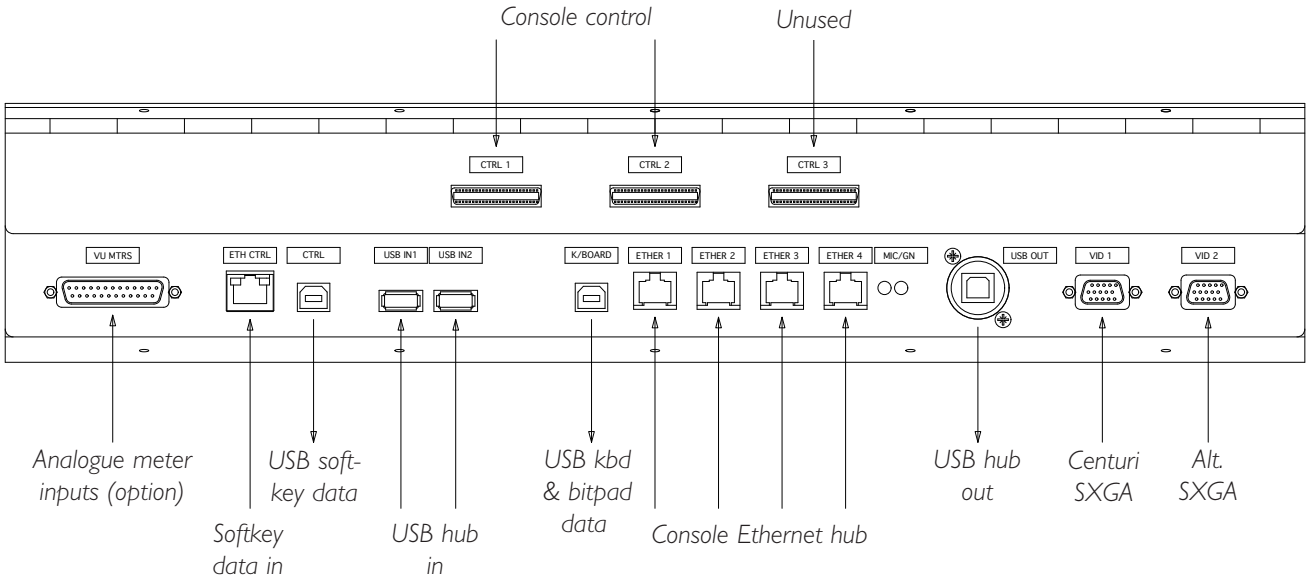

Location of Audio Connectors

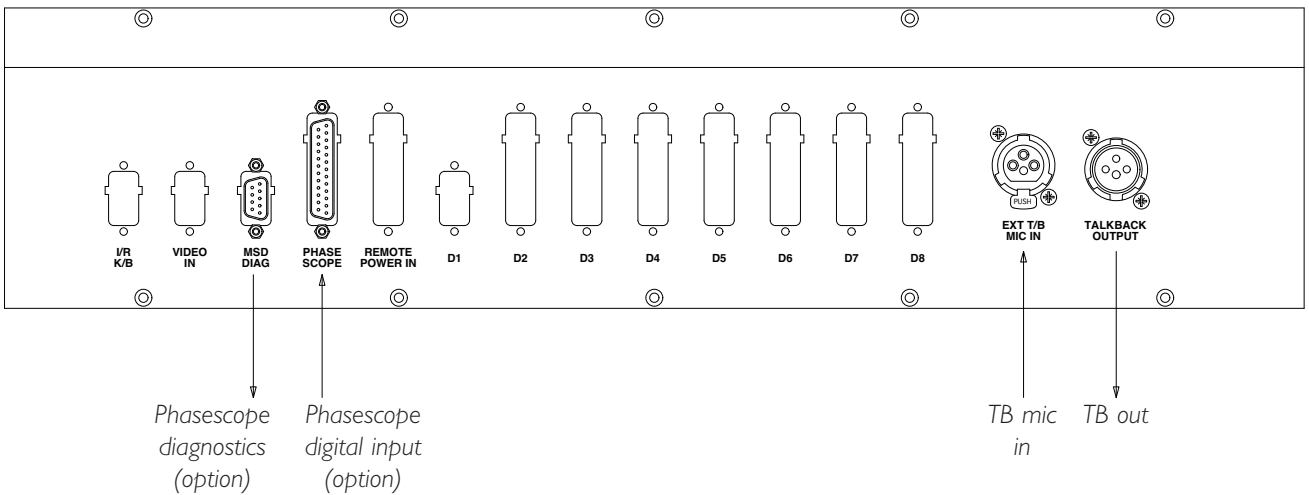

External Keyboard / KVM Switch

There is an inbuilt USB trackball and keyboard included with the C300HD system. These can be used for normal control of the console's mixing and naming functions.

The C300HD console also contains additional hardware that allows its trackball/keyboard to be used to control an external workstation and the console monitor may be used to display the workstation's video output. The switches that control the keyboard and video selection are located on the surround of the monitor section's LCD screen. The switches may be operated individually or can be electronically linked – by pressing both down together – to simplify operation.

'EXTVID' selects between the two SXGA inputs on the connector panel, 'VID 1' and 'VID 2'. 'VID 1' is normally connected to the Centuri Core. 'VID 2' is available for connection to an external SXGA input from a PC or Mac. Maximum supported resolution is 1280 x 1024.

'EXT K/B' routes the output from the USB connector mounted in the Keyboard drawer either to the console's processor or to the Type B USB connector on the connector panel marked 'K/BOARD'. This enables the keyboard and any connected pointing device (Mouse, Trackball etc.) to be routed to an external PC or MAC.

A further Type B USB connector marked 'CTRL' carries USB Keyboard data generated via Console Soft Keys. This can also be routed to a MAC or PC and used to control a DAW via its supported Keyboard short commands supplementing the existing MIDI DAW control offered on C300. The standard connector panel includes a two port USB hub to simplify installation by allowing the simulated USB keyboard data to be merged with the commands from the physical keyboard connected to the console with a single USB link to the PC or MAC running the DAW software.

Two USB A-B cables are supplied with the console to connect the 'CTRL' and 'K/BOARD' USB outputs to the hub inputs.

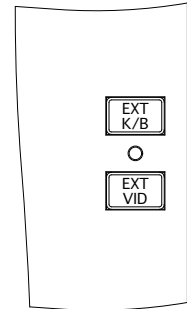

Script Tray (option)

The script tray is a movable transparent panel which fits over a channel bay. It is fitted with rollers to allow it to be moved along straight sections of the console.

A script tray can be added at any time as it does not require modifications to the console.

Loudspeaker Shelf (option)

A flat secure shelf is available for the positioning of loudspeakers, monitors etc. Each shelf is 400mm wide by 253mm deep. A supporting rail is fixed to the console back panel for each speaker shelf. Additional support rails can be fitted so that shelves may be moved to different positions along the console.

TFT External Input (option)

This option allows any of the channel bay TFT screens to be switched to show an external XGA (1024x768) video signal. The switchover may be effected either by a GPI closure triggered from a free button or by a dedicated switch which can be mounted on a custom panel. This option must be specified at time of order. The input will be via an HD15-pin female connector mounted into one of the blanks on the Audio connector panel.

Console Mains Inlet Panel

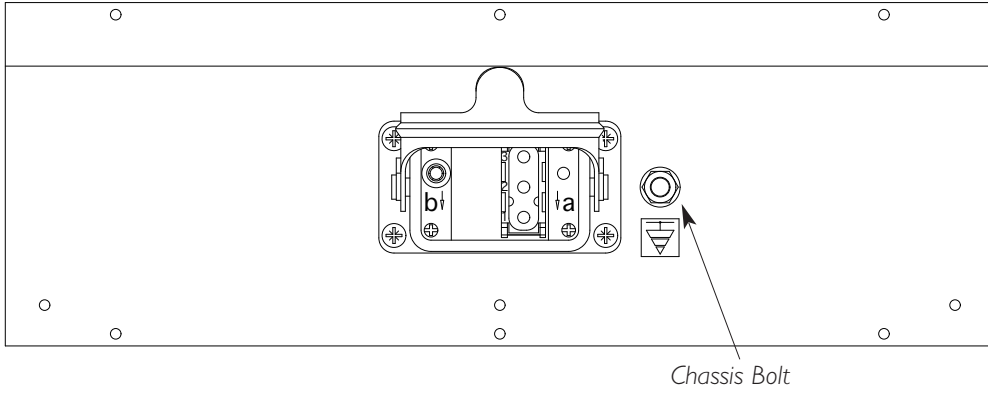

Centuri Mains Inlet Panel

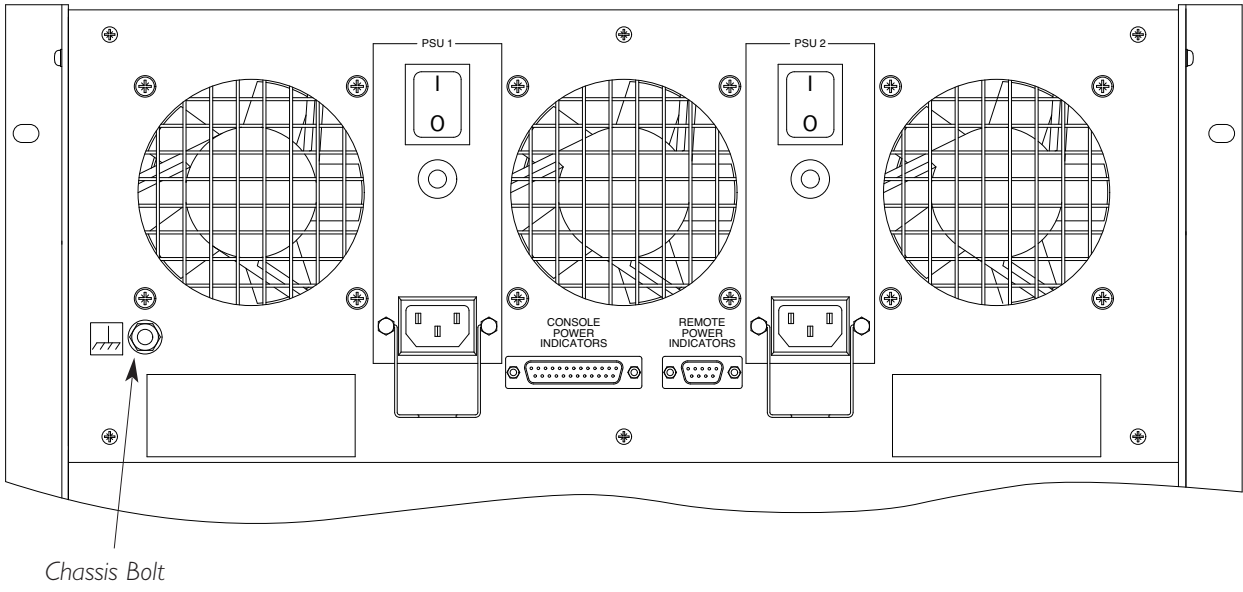

NetBridge Rear Panel

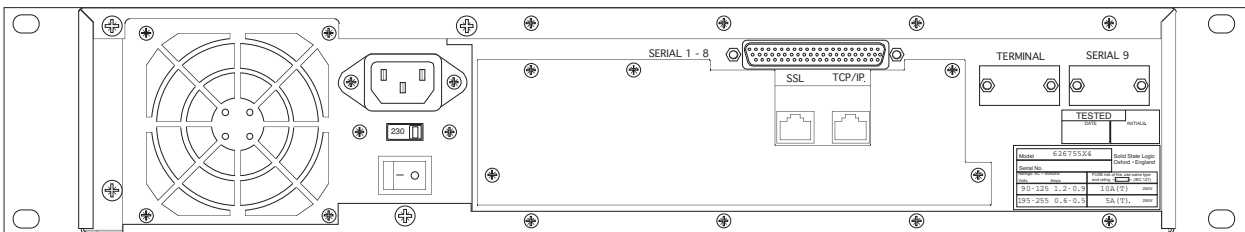

Section 5 – Installation Wiring

This section provides the details for connecting the system components together.

Power Supply Connections

This section refers to the following supplied cables :

Description	SSL Part No.	qty	Notes
Con IEC Free Socket 6A 2m	32VGL362	2	Centuri
Cable Power Digital 2m	32VALXVX	2	Main & Redundant Console power
Lead Chassis Earth 16m	66C93115	1	Console to Centuri

- a) Connect the mains input lead to a suitable supply outlet.

THE MAINS SAFETY EARTH MUST BE CONNECTED

For systems where PSU redundancy is specified – Connect both the console's Harting mains leads to independent mains supplies. For live transmission work it is recommended that one of the power sources be from an un-interruptable source. The console is fitted with auto-ranging power supplies which will accept mains voltages which range from 100 to 240V without adjustment.

THE TWO POWER SOURCES MUST NOT BE FROM DIFFERENT PHASES OF A 3-PHASE SUPPLY.

- b) Connect the Centuri's IEC lead(s) to appropriate mains supply outlet(s). If a redundant PSU module is specified refer to the notes above for suitable supply provision.

The Centuri crate is also fitted with auto-ranging power supplies which will accept mains voltages which range from 100 to 240V without adjustment.

- c) If specified, do not connect a source of power to the NetBridge until the voltage select switch position has been confirmed. The NetBridge operates at either 115V or 230V ranges and its power supply must be set to the appropriate range for the local supply.

Refer to the diagram on page 22 for the location of the voltage select switch.

- d) **Earth Wiring** – A chassis to chassis earth cable needs to be installed between the console and the processor. This keeps the two earths at the same potential thus preventing currents flowing along the signal cables.

Run the green chassis earth cable from the Console's chassis bolt to the similar earth bolt located on the Centuri backpanel.

Control Surface Wiring - Block Diagram

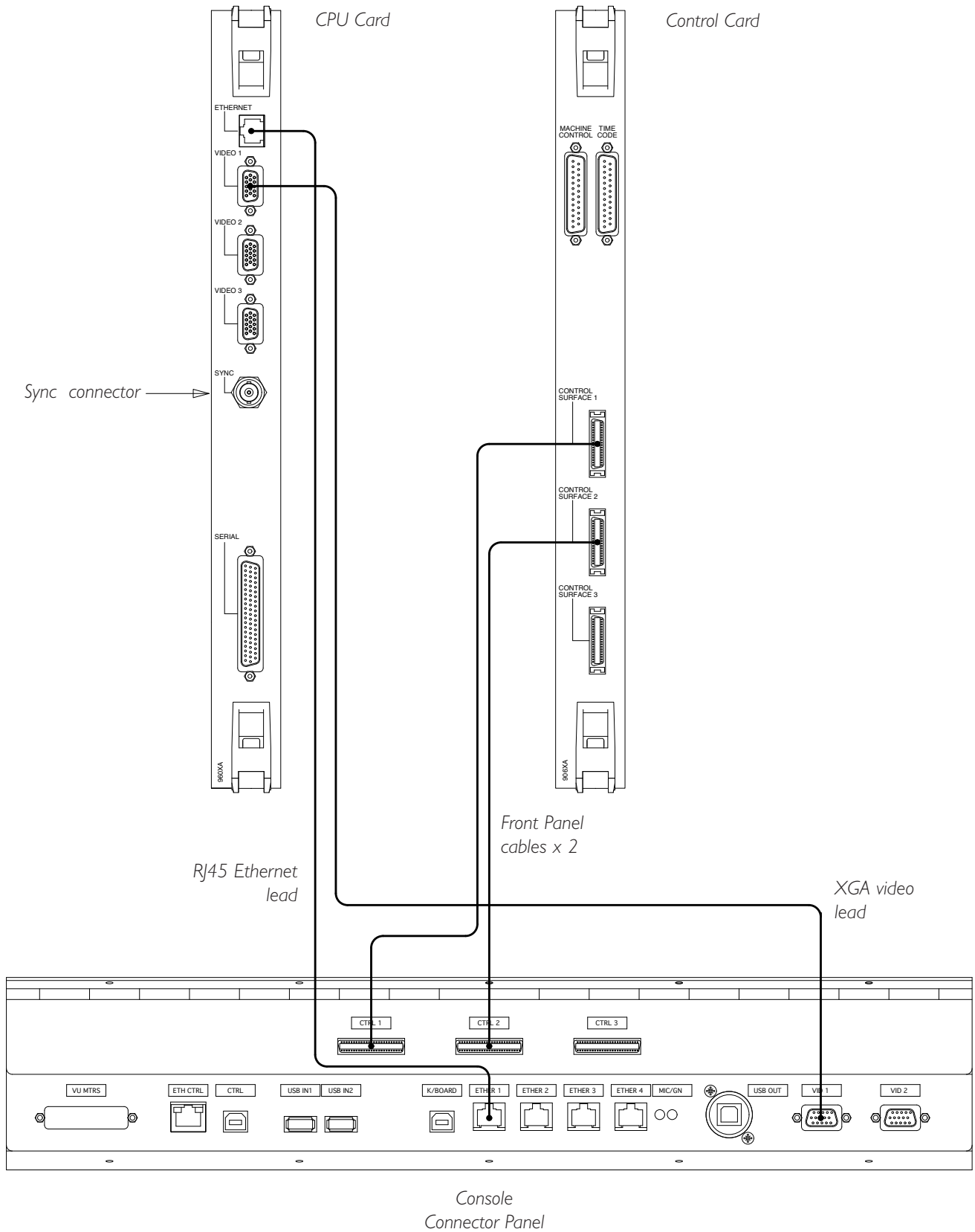

Centuri to Console Surface Connections

This section refers to the following supplied items:

Description	SSL Part No.	qty	Note
Lead RJ45 Shielded 15m	66C67316	1	
Lead Video HD15W D-Type 16m	66DN (16) V1	1	(20)=20m, (25)=25m, (48)=48m
Loom 36-way H/D Digital 14m	66CNA0 (14)	2	24, 44, 64 and 98m options only
Terminator plug 75	32TKB7TC	1	
BNC 75Ω TEE Adaptor	32TKU7CC	1	

a) Front Panel Cables

Locate the two MDR-MDR front panel cables and connect them between the Centuri Control card and the console interface panel as shown opposite. Although there are three connectors at both the Centuri and the console ends, only connectors 1 and 2 are used.

These cables are symmetrical, having the same connectors at each end.

The front panel cables are only supplied in 14, 24, 44, 64 or 98m lengths. This is due to a timing requirement for the high speed serial data. Do not attempt to shorten these cables. The connectors on these cables are not removable.

b) Network Cable

The Centuri processor uses an RJ45 Ethernet network to communicate with the C300HD console, Stageboxes and NetBridge. The console has a built-in 4-way Ethernet repeater.

Connect the Ethernet lead between the Centuri CPU card and any of the four 'Ether' sockets beneath the console.

If Netbridge is specified then a second RJ45 Ethernet lead will be supplied with the system. This lead is connected between the console and the 'SSL Network' connector on the NetBridge rear panel.

c) Video Cable

There are three video outputs available on the CPU card. Video 2 and Video 3 are static background displays. Video 1 is used for the Monitor section display. The video output is XGA standard – 1024 x 768 @ 60Hz. The connectors are high-density 15-pin D-type (HD15).

Connect the video cable as shown in the diagram opposite. The cable is male-male so does not have to be run in a particular direction.

It is not recommend that the supplied video cable be extended. Doing so may reduce the image quality as the cable is matched to function over long runs; the cables are of a high quality individually screened type. Longer cables are available to order.

d) Sync Cable

Connect the source of black-and-burst (or composite) or Tri-sync video to the SYNC IN connector on the processor crate using the T-adaptor and 75Ω terminator supplied to provide cable termination.

Micamp Input Card

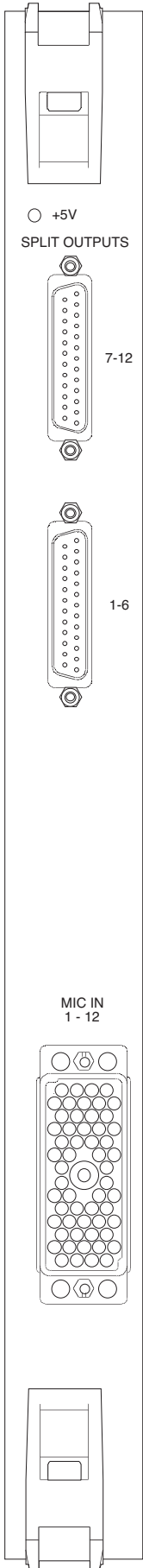

○ +5V
SPLIT OUTPUTS

7-12

1-6

MIC IN
1 - 12

*Split Output Connectors
25-pin D-type female*

*Microphone input Connector
Varicon 56-way female*

Analogue I/O Card



ANALOGUE IN
1 - 24

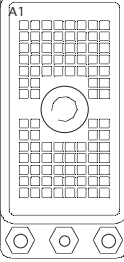

*Analogue Input Connector
DL96 female*

ANALOGUE OUT
1 - 24

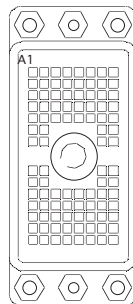

*Analogue Output Connector
DL96 female*

I/O – MicAmp Card (SSL ref. 908)

Each MicAmp Input Card contains 12 Microphone circuits. The inputs are accessed via a Varicon (aka. EDAC or Elco) 56-way female connector.

The split outputs are accessed via two 25-pin D-type female connectors.

Refer to Appendix C for the connector pinouts.

SSL is able to supply mating connectors if requested, (at additional cost).

If more than one micamp card is fitted then the card furthest to the right will have the lowest input number and the channel numbers will increment by 12 as each card is added. Any cards added subsequently, should be placed to the left of any existing cards otherwise the channel numbering will be altered.

I/O – Analogue input/output Card (SSL ref. 904)

The Analogue Card provides 24 circuits of electronically balanced input and output. These circuits are accessed via Canon DL 96 way female connectors; mating connectors are available to order

Refer to Appendix C for the connector pinouts.

As is the case for the MicAmp, cards added subsequently should be placed to the left of existing cards.

The default line-up level for analogue I/O is 0dBFS = +18dBu. This level may be globally altered and can range from +9dBu to +24dBu. The value can be adjusted from a setup screen to match the standard operating level for the facility.

When assigning analogue output channels as insert sends, the routing system will automatically assign the same input channel number as the corresponding return. It is therefore necessary to physically wire outboard equipment so that circuit allocation follows this arrangement.

Digital I/O Card

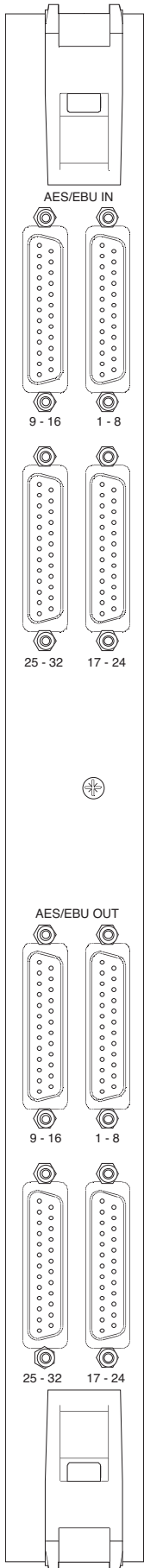

*AES/EBU Input Connectors
25-pin D-type female*

*AES/EBU Output Connectors
25-pin D-type female*

**MADI I/O Card
(Copper version)**

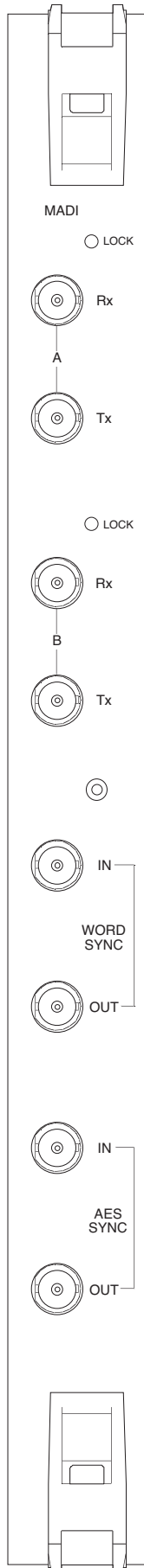

*MADI Link A
BNC 75Ω*

*MADI Link B
BNC 75Ω*

*MADI Word Sync
BNC 75Ω*

*AES Sync
BNC 75Ω*

I/O – Digital Input/Output Card 110Ω(SSL ref. 902XF)

The Digital Input Card provides 32 balanced AES/EBU signal pairs of input and output. All circuits are accessed via 25-pin D-type female connectors.

Refer to Appendix C for the connector pinout for this card. Mating connector kits can be ordered for the card.

As in the case of the Analogue I/O, cards added subsequently should be placed to the left of existing cards.

When assigning digital output channels as insert sends, the routing system will automatically assign the same input channel number as the corresponding return. It is therefore necessary to physically wire outboard equipment so that circuit allocation follows this arrangement.

I/O – Digital Input/Output Card 75Ω(SSL ref. 902XJ)

This version of the Digital I/O card is externally identical to the 110Ω version (apart from its designation number). The Impedance of each input and output circuit however, is now 75Ω and unbalanced for correct matching to installations using co-axial cabling.

A separate BNC interface panel is available as a cost option. This is 2U high and is fitted with 64 chassis mounted BNC plugs – 32 input and 32 output. 1 metre D25–D25 interconnecting looms are provided. These looms should not be extended beyond 1m as the signals are unbalanced and signal quality may be reduced.

As in the case of the Analogue I/O, cards added subsequently should be placed to the left of existing cards.

When assigning digital output channels as insert sends, the routing system will automatically assign the same input channel number as the corresponding return. It is therefore necessary to physically wire outboard equipment so that circuit allocation follows this arrangement.

I/O – MAD1 Card (SSL ref. 902XG copper version / 902XH/K fibre versions)

The MAD1 I/O Card can operate in 56 or 64 channel mode at Fs or in 28/32 channel modes at 2Fs. Both Word Clock and AES-3id (unbalanced) sync inputs and outputs are fitted.

If the incoming MAD1 signal is synchronous, no additional sync reference is required. However if a valid Word Clock or AES sync signal is connected, the card will automatically default to using the external sync reference to decode the MAD1 data stream. A Sync reference is always required if the incoming MAD1 stream is asynchronous or if varispeed and/or sample rate conversion is required.

The fibre optic versions of the card are available with singlemode or multimode connections. Ensure that the matching cable type is used. The recommended maximum cable length for the singlemode version is 2km and for the multimode version is 550m.

GPI I/O Card

*GPI input Connectors
25-way D-type Male*

*GPI output Connectors
25-way D-type Female*

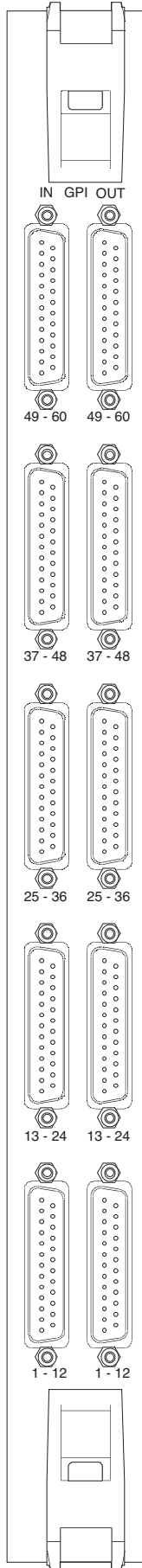

I/O – GPI I/O (SSL ref. 907XA)

The GPI I/O Card contains 60 circuits of opto-isolated input and 60 circuits of relay-closure output. Inputs are accessed by 25-pin D-type male connectors and outputs by 25-pin D-type female connectors; mating connector kits are available to order.

Both the input and output circuits are fully isolated from the processor electronics. On all output connectors, there is a protected source of +15V available and a 0V reference is available on each input connector.

The input and output signals can be either latching or momentary. This setting is individually assigned in software via the touch screen. When set to momentary the input signal duration must be greater than 50mS.

When used for track arming and tally, the tally must return to the same number input as the output signal, (ie. the tally for GPI Out 1 will be on GPI In 1).

GPI Outputs

The switch closure is by DIL relay. Contact rating is 100Vdc, 125Vac, 100mA max. Do not use the output contacts to directly switch capacitive or reactive loads, always use an external relay with a suitable contact rating.

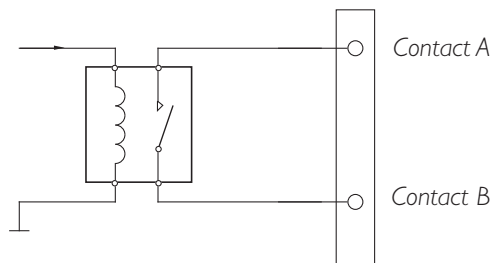

GPI Inputs

The signal input requires AC or DC voltage between 4V and 30V. The current drawn is approximately 10mA.

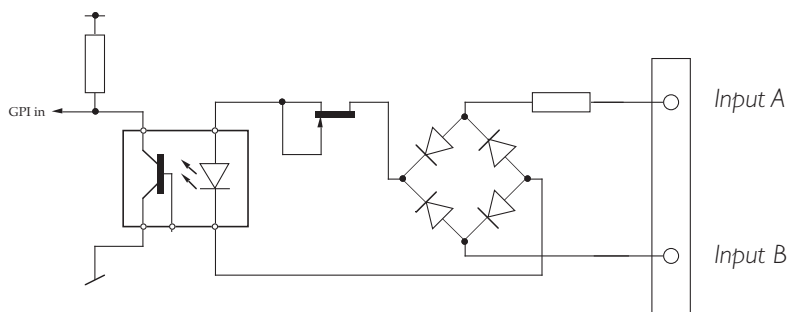

Stagebox Madi Fibre Connectors and Panels

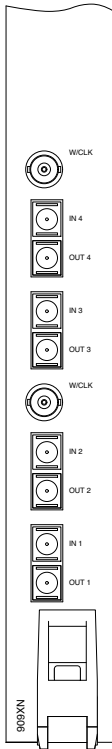

Centuri Link Card
Fitted with two redundant Madi interfaces

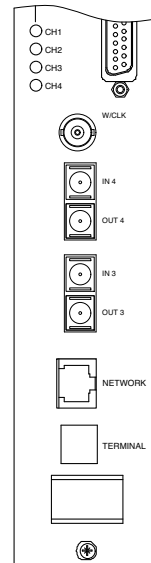

Stagebox CPU Card

C-SB Connection Diagrams

Connection with UTP control link (100m max)

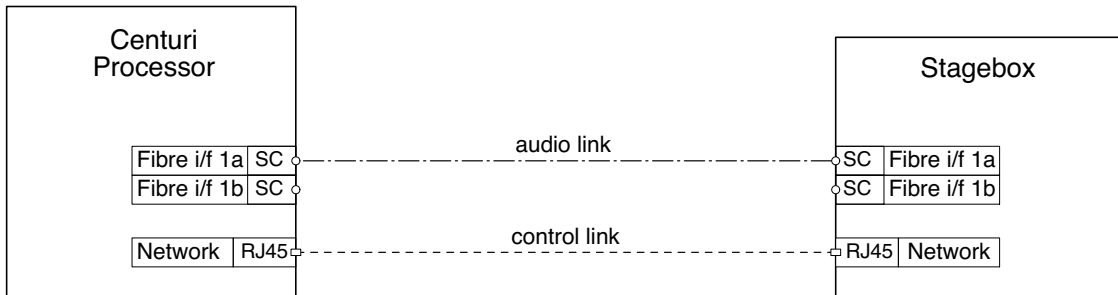

Duplex fibre (SC) - - - - -
Ethernet (RJ45) - - - - -

Redundant connection with fibre control link (>100m)

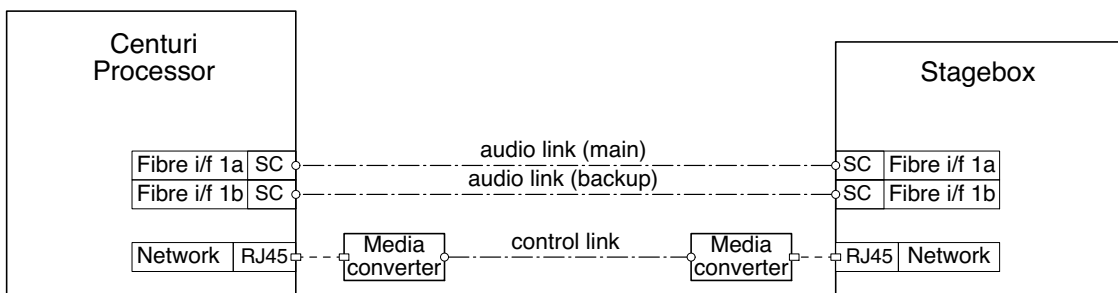

Stageboxes & Fibre Links

The C-SB Stagebox utilises fibre-optic Madi cable for audio connection between itself and the Centuri processor. This provides the advantages of noise immunity, reduced weight and bulk of wiring and the elimination of earth loops. A separate control signal (for gain, pad, filter switching etc.) is carried over the SSL Ethernet network – this control signal can be converted into fibre for runs longer than 100m.

The cables required for audio connection are duplex fibre with SC connectors (flat not APC type). A redundant connection will require a second cable. A 2m duplex lead is provided as standard with each stagebox. The interfaces may be specified as multimode or singlemode fibre types. The maximum cable length for a multimode Madi connection is 550m, and for singlemode is 2km.

Longer fibre cables and/or ruggedised OB cable using adaptor panels/patch panels may be available to order. SSL is able to suggest a range of fibre solutions although the facility may prefer to provide its own fibre installation. Details of fibre installation options should be discussed with SSL's Project Engineering Department prior to the time of order.

When Stageboxes are specified, it is recommended that a 10/100 Ethernet hub/switch is installed so as to provide isolation for the remote network connection(s). A 1U rack mounting 16-port switch is available to order.

When locating Stageboxes at distances greater than 100m from the Centuri rack the Ethernet control cable will have to be buffered – using an Ethernet repeater/switch – or, ideally, converted to fibre by using proprietary media converters.

Up to four Madi fibre interfaces. The Centuri Routing card can be fitted with

The BNC connector associated with each Madi port provides an output of system Wordclock.

NetBridge Installation

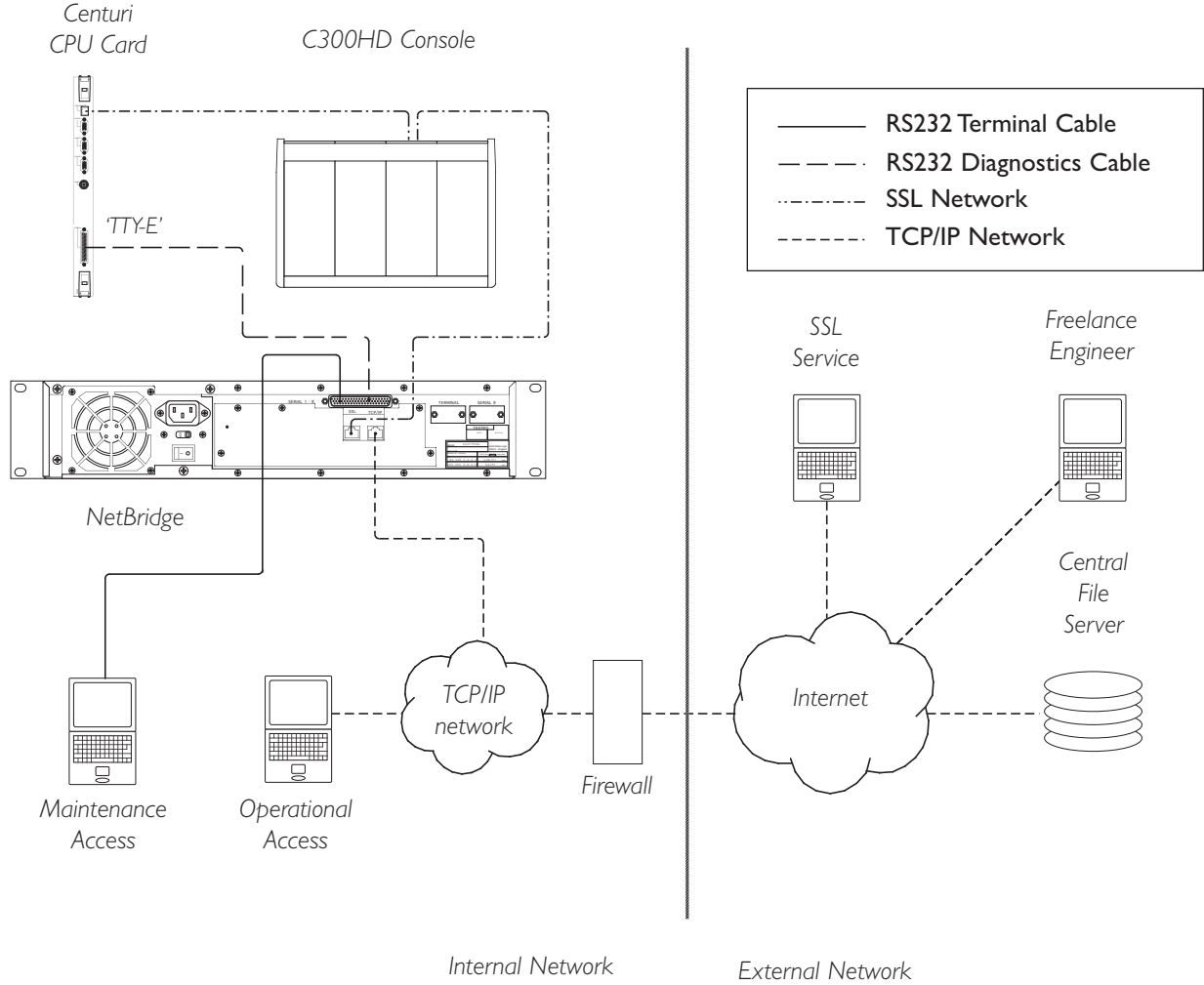

NetBridge Installation

NetBridge has eight serial ports plus two Ethernet ports. The first Ethernet port is connected to the C300's network. The second port is for connection to the Internet; this can be via DHCP server (for a dynamically assigned IP address), or a static IP address defined by the operator. The IP number (in 'dot' notation) will be shown on the front panel while the unit is powered.

In facilities with a firewall to the Internet, this address is likely to be for internal use within the installation and not visible to the outside world. For external diagnostic access, the firewall will have to be set to pass (and redirect) the appropriate incoming traffic to the NetBridge unit, which will have to be agreed with and configured by the facility's IT staff.

NetBridge operation is more fully described in a separate document which is supplied with the hardware.

Connection

The eight serial ports are all located on the single 62-pin connector (a breakout adaptor is provided). Serial ports 1 to 7 can be connected to the 'Console' port on the Centuri's CPU card (on port TTY-E), allowing one NetBridge to have terminal diagnostic access to up to seven C300HD processors.

Serial port 8 may be connected to a data terminal (or software terminal emulator) for permanent local diagnostic access without requiring login. (see Appendix C for cable details)

Access

For security purposes, the NetBridge file transfer functions can only be accessed by one registered user who must be logged into the Central File Server (CFS). This uses the secure HTTPS protocol, which must be passed through any firewall (and redirected as required), although this is unlikely to cause any security concerns as it has 128bit Secure Socket Layer encryption. For file transfer between the console and the CFS, the user must be logged in at the console itself. For file transfer between the CFS and another computer (eg. authorised freelance engineer or SSL support staff), the user may login from an Internet connection, with the same username and password security requirements.

Diagnostic access also uses 'Secure Socket Layer' encrypted login, and is available to multiple users simultaneously over the TCP/IP network link. They can log-in as terminal users and each run the terminal client application on the NetBridge to give them switched access to the seven serial ports.

File Transfer

If a console operator wishes to export a session template to the CFS so that others may create offline setups from it, secure login from the C300HD allows that file to be uploaded to the facility's private account on the CFS, so that registered users can download the template and upload their own setups. Any existing setups in that account can be downloaded from the CFS to the console's hard disk.

Remote Diagnostics

In order to access a C300's diagnostics through its NetBridge, first you need to know the IP address of that unit (on the front panel, or defined by a firewall/router), which can be determined by contacting the facility's IT staff or consulting the security arrangements agreed with them. Once a secure connection has been made, running the terminal server application on the NetBridge will allow you to connect from the Internet to any of the seven 'console diagnostic' ports on that NetBridge.

Talkback Block Diagram

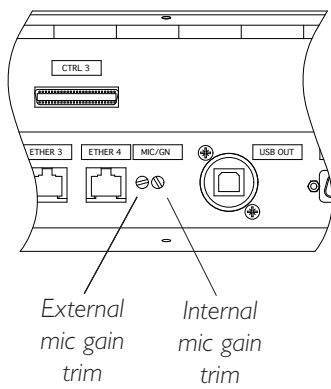
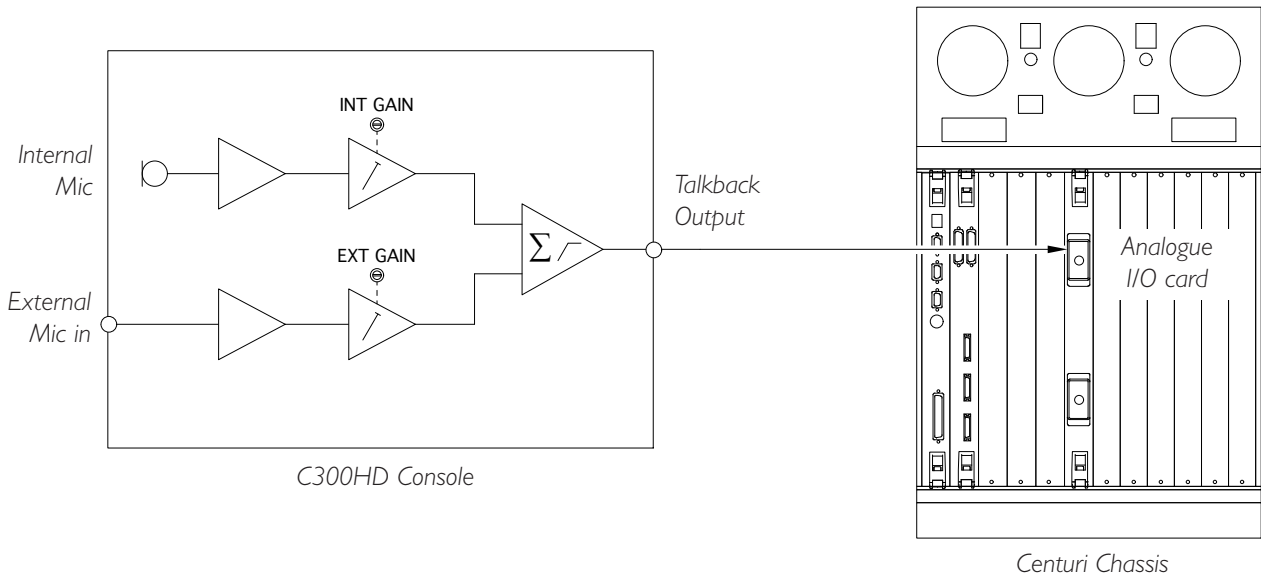

Connector Panels

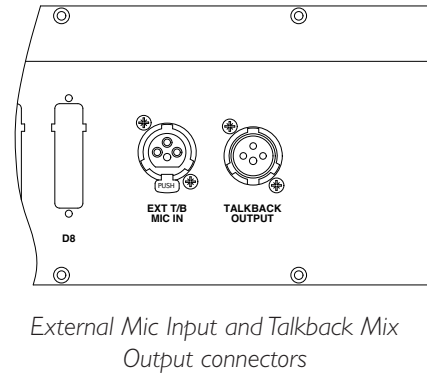

Talkback and Oscillator

Talkback Connections

The C300HD console contains a built-in talkback microphone and amplifier. In addition, a second input is available for connection to an external dynamic microphone. This input is mixed with the internal T/B mic and the combined signal is available via an XLR connector on the audio interface panel beneath the console. This output signal should be connected to an analogue input circuit in the Centuri processor. The circuit chosen can then be assigned as the talkback source via the console's routing.

The gain of each mic signal can be independently adjusted. Access to the trim controls is from beneath the console on the console interface panel.

The external mic input is via a 3-pin XLR female labelled 'Ext T/B Mic In'.

The mixed T/B output is via a 3-pin XLR Male labelled 'Talkback Output'.

Oscillator Connections

The C300HD includes an inbuilt software oscillator capable of generating a range of sinusoidal frequencies as well as pink noise. This signal can be assigned to any relevant output without additional cabling.

Alternatively, an external oscillator (either analogue or digital, mono or stereo) may be used. In this instance one or two circuits should be allocated on an input card, they can then be assigned as the oscillator source.

Refer to Appendix C for connector pinouts.

Meter and Phasescope Wiring

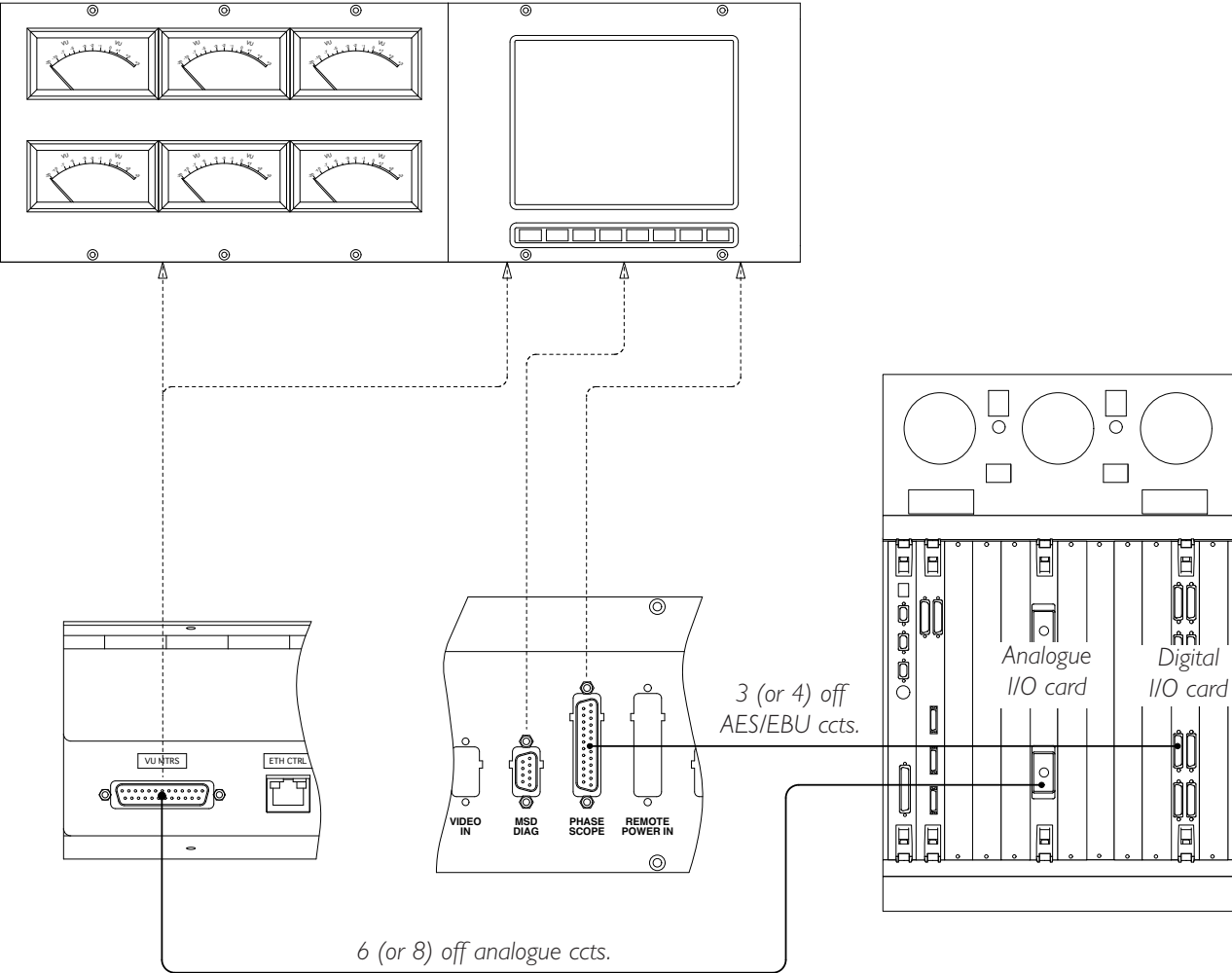

Meters and Phasescope

A Centre Section of the C300HD console can optionally be equipped with six off analogue VU meters with screening for 5.1 monitoring channels. In addition, each Centre Section may be fitted with an LCD phasescope. Two standard phasescope types are available, the MSD600C or the RTW 10830. Other custom meter solutions may be possible. Note that if the number of mechanical VU meters fitted is increased to eight, then there is no longer room for a phasescope.

Cable connections to the meters and phasescope will need to be run between the Centuri and the Console. Both balanced analogue and 110Ω digital cables may be necessary depending on configuration. These cables are not supplied by SSL.

The MSD600C 5.1 phasescope has inputs for 6 digital signals (3 AES/EBU pairs), plus a serial diagnostic port.

The RTW 10830 has eight digital input signals, eight digital output signals, eight analogue input signals plus a remote control port. Note that the analogue input signals would normally feed both the phasescope and the mechanical meters.

The signals for the Analogue meters could be paralleled from the console main output signals or, alternatively, independent feeds from the analogue output card.

Refer to page 53 for the analogue meter wiring pinout and page 54 for the digital wiring.

DAW MIDI Interface Panel

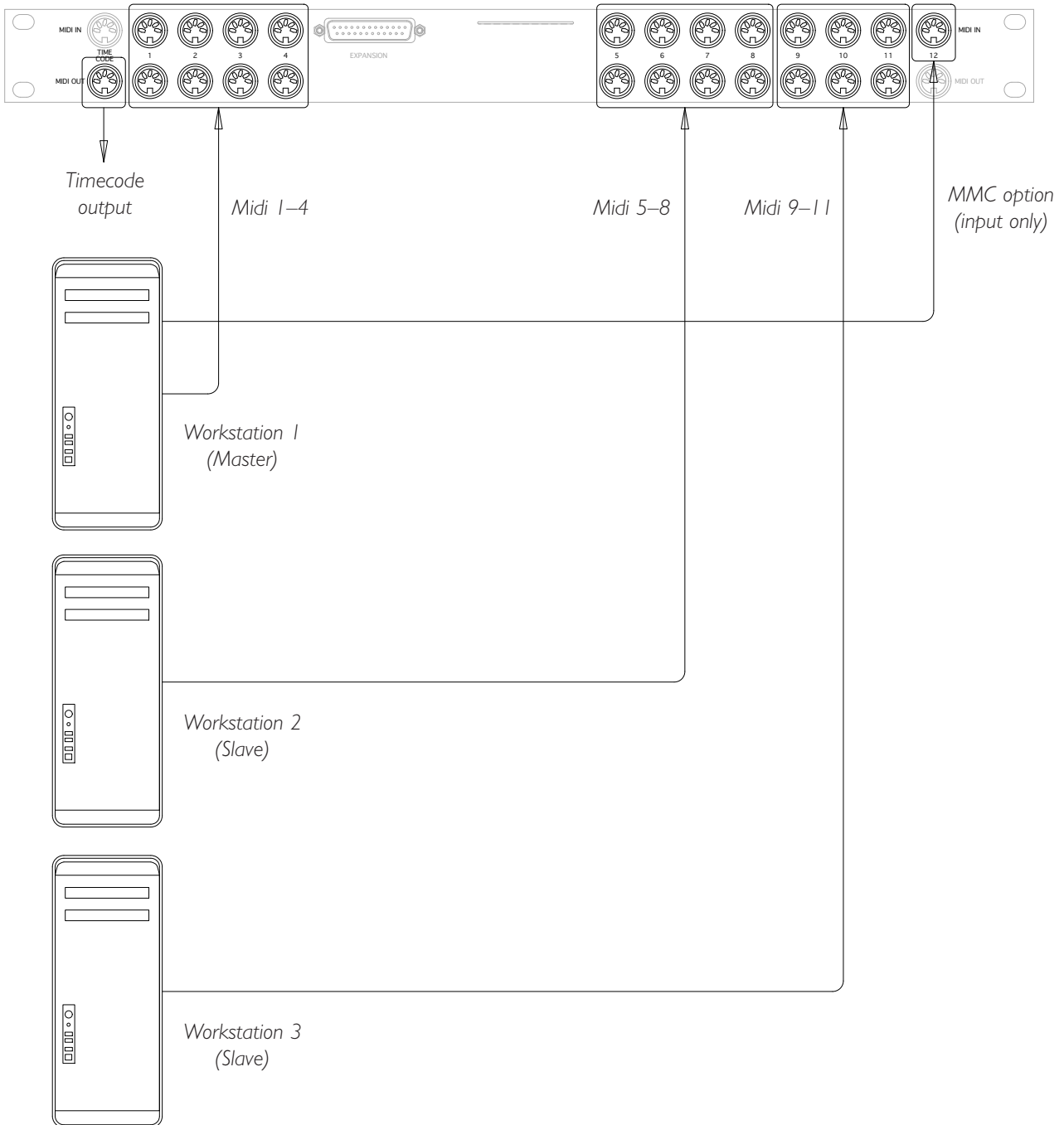

DAW MIDI Connection (Option)

The DAW interface is supplied as standard and a separate I/O breakout panel is provided for access to the system's MIDI circuits. This panel is connected to the lower rear of the Centuri chassis and should be mounted in a suitable position in the equipment rack. (See diagram below).

The panel provides access to 12 pairs of MIDI ports for workstation control using the 'HUI' protocol together with a MIDI timecode output from the console's internal timecode generator. The port marked 'IN Timecode' is currently not used.

Each pair of DAW ports supports 8 channels of workstation control. These ports can be distributed amongst four different workstations. The maximum number of ports that can be utilised for control is workstation specific – for example, the Digidesign Pro Tools is limited to a maximum of 4 ports. Please consult the DAW documentation to determine how many physical ports can be used. In most cases the DAW software supports banking so that the physical console control channels can be paged through all the available tracks in a workstation session.

Port 12 'IN' also accepts the MMC (Midi Machine Control) locate command. This is used in conjunction with timecode from the master DAW to update the desk timeline.

Standard MIDI 5-pin DIN cables should be used to connect the workstation.

The 'Expansion' connector has no function on C300.

Refer to Appendix G page 68 for additional information on machine control.

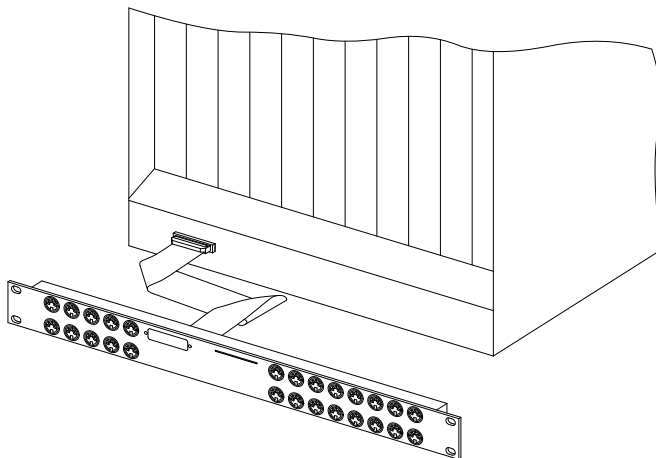

*Midi breakout panel connection
at the rear of the Centuri chassis*

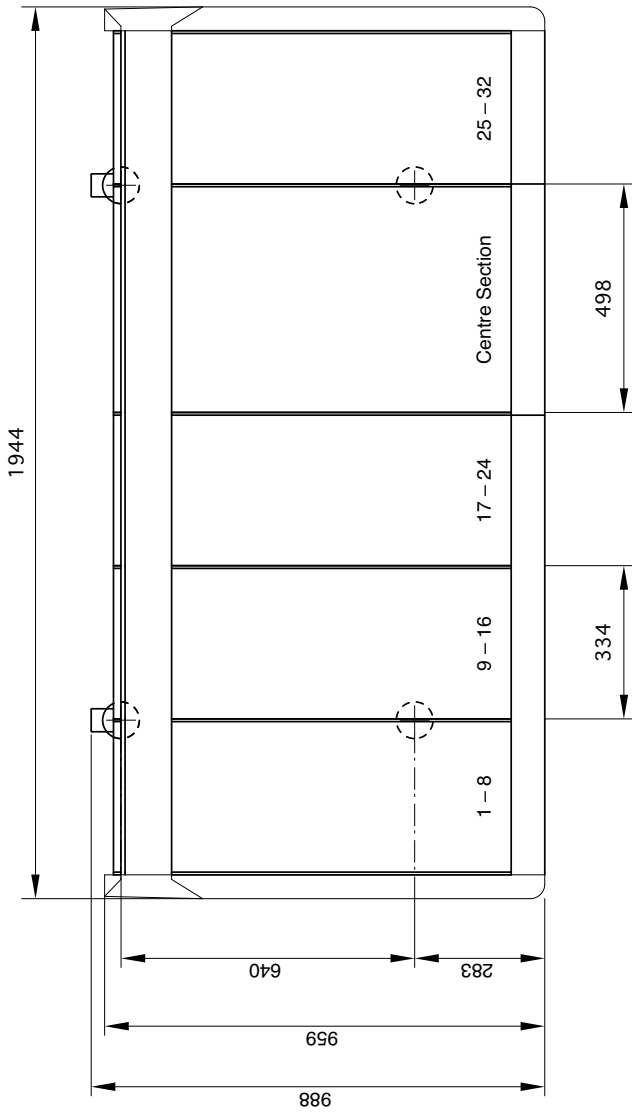
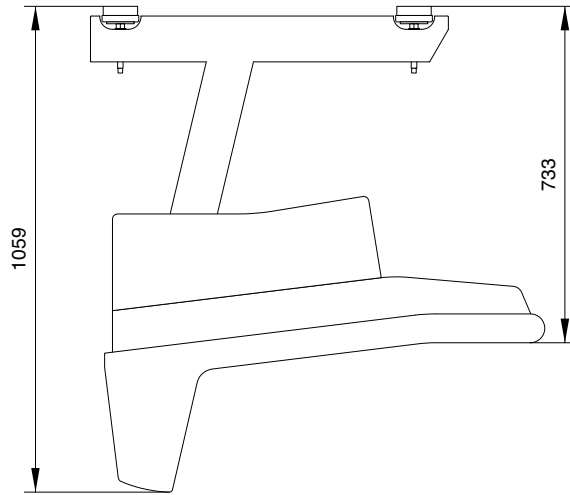

32 channel footprint drawing.

Refer to table opposite when calculating frame configurations. Alternatively, contact

SSL Project Engineering at: projeng@solidstatelogic.com

Solid State Logic	
S O U N D I I V I S I O N	
Title:	Footprint C300 – 32 Channels
Client:	Standard Configuration
Sheet:	Proposal
Drawn by:	GC
Revision:	0.1
Date:	21/02/08

Appendix A: Specifications

C300HD Console				
<i>Parameter</i>	<i>Condition</i>	<i>Value</i>	<i>Unit</i>	<i>Notes</i>
Height	To top of meter trim	1056	U	
Height adjustment		-0 +45	mm	
Width	Centre Section plus end trims	608	mm	
	8 fader channel bay	334	mm	
	Producer's table section	491	mm	
	Additional Master Section	498	mm	
Depth		988	mm	
Weight	24 channels with 2 legs	164	kg	
	8 fader bay (add/subtract)	35	kg	
	Additional leg	13	kg	
Heat Dissipation	24 channels, single Master section	270	W	<i>approximately</i>
	8 fader bay (add/subtract)	70	W	<i>approximately</i>
Voltage	Range	100 – 240	V	<i>AC only ± 10%</i>
Current	48ch. Maximum over voltage range	10.3 – 4.3	A	
Power Factor		0.95		<i>approximately</i>
Fusing	No user-accessible fuses			
Noise	Fanless			
Connectors	Power in main/backup	Harting™ Modular 3-pin		
	Network	RJ45 100 baseT		
	Control Surface	3M™ MDR high-density 50-way female		
	Video in 1 and 2	HD15 female		
	Trackball out	USB B female		
	External USB in	USB A female		
	Phasescope input – digital	25-way D-type female	<i>(where specified)</i>	
	Phasescope diagnostics/control	9-way D-type female	<i>(where specified)</i>	
	Meter inputs – analogue	25-way D-type male	<i>(where specified)</i>	
	Osc/Status Lock	25-way D-type female		
	External T/B mic input	XLR 3-way female		
T/B audio output	XLR 3-way male			

Centuri Processor Crate				
Parameter	Condition	Value	Unit	Notes
Height		15	U	
		665	mm	
Width		19	in	
	Case only without rack ears	449	mm	
Depth		592	mm	<i>excludes connectors/cables</i>
Weight (†)		35 – 45	kg	<i>depending on I/O fitted</i>
Heat Dissipation	32 DSP, no I/O	300	W	<i>minimum</i>
	64 DSP, 24 mics, 48 analogue	550	W	<i>typical</i>
	128 DSP, 48 mics, 96 analogue	910	W	<i>maximum</i>
Voltage	Range	100 – 240	V	<i>AC only</i>
Current	Maximum over voltage range	12.3 – 4.9	A	
Power Factor		0.95		<i>approximately</i>
Fusing	Thermal current trip. No fuses	16	A	<i>each input</i>
Noise		75	dB(A)	<i>approximately</i>
Connectors	Power in 1 and 2	IEC male		
	Network	RJ45 100 baseT		
	Sync in	BNC 75Ω analogue video		
	Video out 1, 2 and 3	HDI15 female		
	Serial	62-way HD D-type female		<i>9-way breakout lead supplied</i>
	Control Surface	3M™ MDR high-density 50-way female		
	Machine Control	25-way D-type male		
	Timecode	25-way D-type female		
	Control Power Indicators	25-way D-type female		
	Remote Power Indicators	9-way D-type male		<i>unused</i>
	Expansion	25-way D-type female		<i>unused</i>
	MIDI	5-pin 180° DIN female		

† Centuri must be supported on rack shelves. Do not rely on the rack ears alone.

Netbridge				
Parameter	Condition	Value	Unit	Notes
Height		2	U	
		89	mm	
Width	Case only without rack ears	19	in	
		432	mm	
Depth		360	mm	<i>excludes connectors/cables</i>
Weight (†)		11	kg	
Heat Dissipation	32 DSP, no I/O	45	W	<i>maximum</i>
Voltage	Switch selectable	115 or 230	V	<i>AC only</i>
Current	At 115V input	0.5	A	
	At 230V input	0.2	A	
Fusing	No external fuses			
Noise		50	dB(A)	<i>approximately</i>
Connectors	Power in	IEC male		
	Network – TCP/IP	RJ45		
	Network – SSL	RJ45		
	Terminal	9-way D-type male		
	Serial	62-way HD D-type female		<i>9-way breakout lead supplied</i>

† Netbridge must be supported on rack shelves. Do not rely on the rack ears alone.

C-SB Stagebox				
<i>Parameter</i>	<i>Condition</i>	<i>Value</i>	<i>Unit</i>	<i>Notes</i>
Height		14	U	
		620	mm	
Width		19	in	
	Case only without rack ears	432	mm	
Depth		462	mm	<i>excludes connectors/cables</i>
Weight	Rack with single PSU unit	19	kg	
	Each Mic input or Line output card	1.7	kg	
	Additional PSU module	5.8	kg	
Heat Dissipation (†)		380	W	<i>maximum with 48ch fitted</i>
Voltage	Range	100 – 240	V	<i>AC only</i>
Current	At voltage range	10.0 – 3.9	A	<i>maximum with 48ch fitted</i>
Fusing		6.3(T)	A	<i>1.25" time delay</i>
Noise	Fanless			
Connectors	Mains supply in	IEC male		
	Mains supply output (x2)	IEC female		<i>6A max total</i>
	Network – SSL	RJ45		
	Microphone input	XLR 3-pin female		<i>pin 2 hot</i>
	Insert send	25-pin D-type male		
	Audio interface (FibreLink)	Duplex SC fibre optic		

(†) Cooling is via vents at the top and bottom of the front panel. Do not obstruct these vents – refer to Appendix F for additional information.

Appendix B: Connector Details

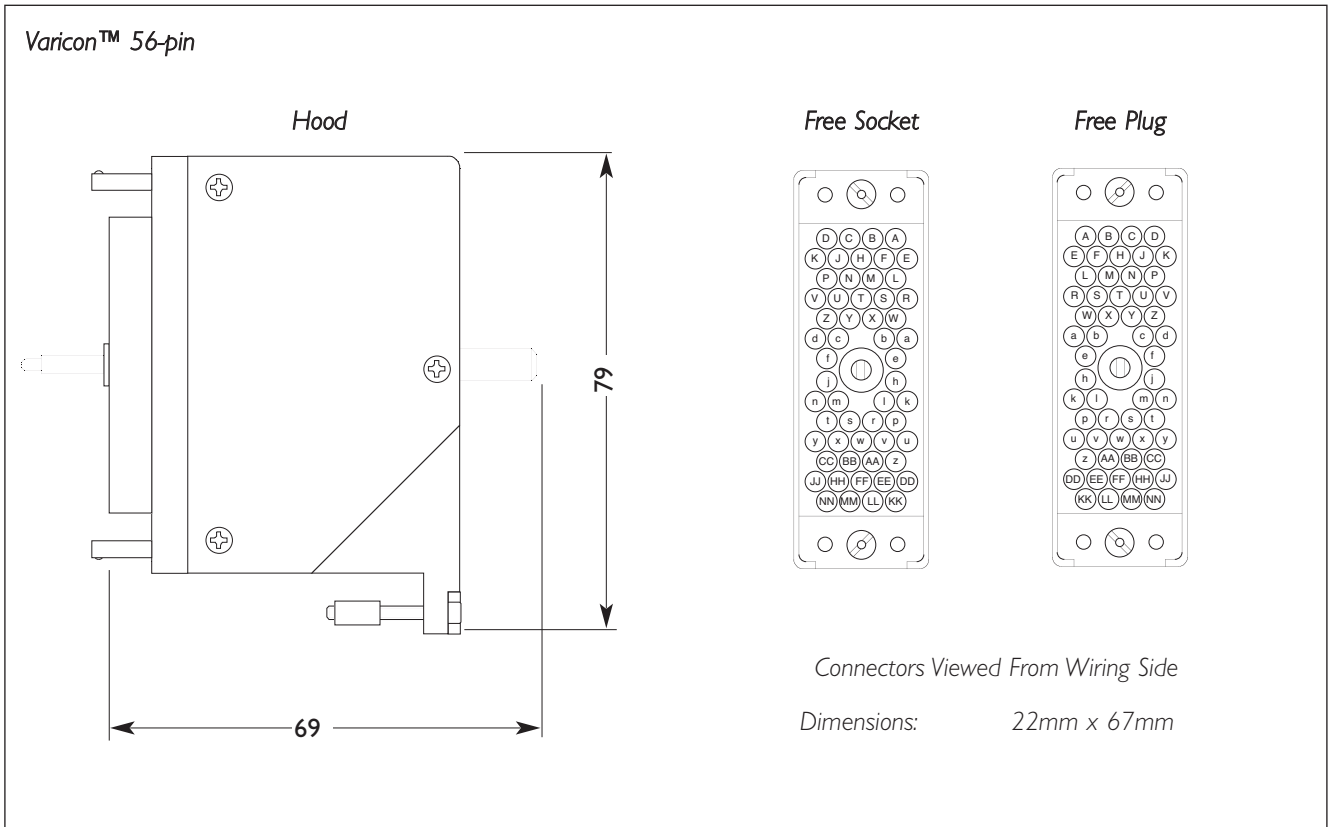
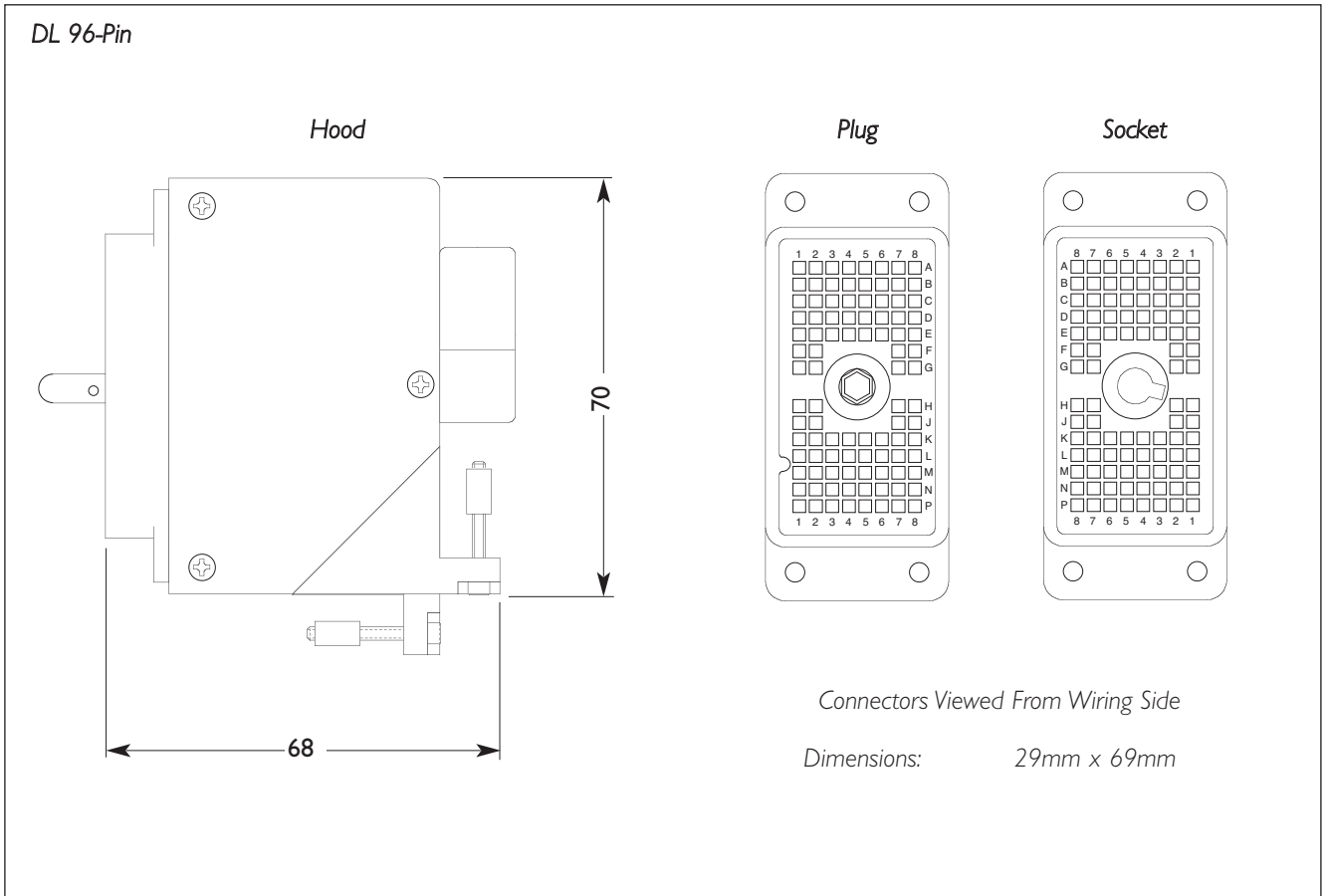

XLR 3-Pin

Dimensions: 19 x 60mm (approx.)
 Cable Dia: 8-12mm (typical)

Pinout for balanced audio:

- Pin 1 - Screen/Ground
- Pin 2 - Hot (+ve)
- Pin 3 - Cold (-ve)

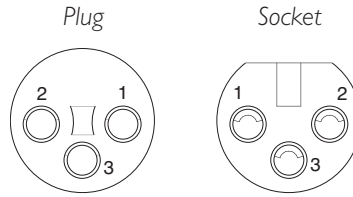

Connectors Viewed From Wiring Side

DIN 5-Pin 180°

Dimensions: 15mm dia.
 Cable Dia: 4mm - 7mm (typical)

Pinout for MIDI signals:

- Pin 1 - n/c
- Pin 2 - Screen
- Pin 3 - n/c
- Pin 4 - Midi +
- Pin 5 - Midi -

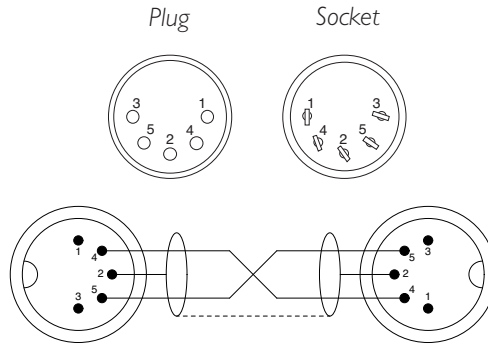

Connectors Viewed From Wiring Side

Midi lead construction

D-Type Multipin

25-way

Dimensions: 55 x 15mm (approx.)
 Cable Dia: 8mm (typical)

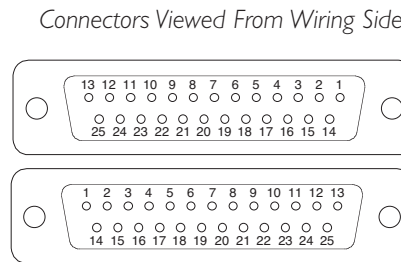

Plug

Socket

9-way

Dimensions: 35 x 15mm (approx.)
 Cable Dia: 7mm (typical)

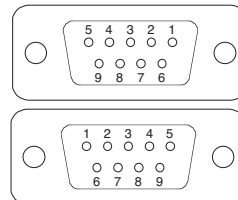

Plug

Socket

HD 15-way

Dimensions: 35 x 15mm (approx.)
 Cable Dia: 12mm

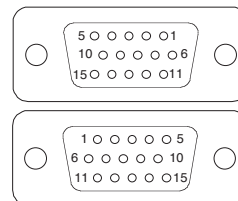

Plug

Socket

RGBHV (XGA) connector

Harting Mains Insert

- Pin 1 LIVE
 - Pin 2 n/c
 - Pin 3 NEUTRAL
- Earth contact is via Earth pin in the housing frame

Note: The inserts utilise crimped pins which are not removable.

- Part 3-way socket housing SSL Part Number 32VAK3DC
- 40A Contact 32VAQXEX

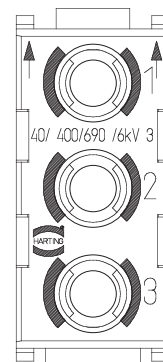

Socket Viewed from wiring side

Appendix C: Connector Pinouts – C300HD Console

Meter Inputs		(Analogue Circuits)		
Location:		Console Connector Panel		
Connector Type:		25-way D-type male		
<i>pin</i>	<i>Description</i>	<i>Notes: VU or PPM</i>	<i>Notes: RTW10830</i>	
1	Meter 1 input +	Left meter		Input 1
14	Meter 1 input -			
2	n/c	Centre meter		Input 2
15	Meter 2 input +			
3	Meter 2 input -			
16	n/c	Right meter		Input 3
4	Meter 3 input +			
17	Meter 3 input -			
5	n/c	LS meter		Input 4
18	Meter 4 input +			
6	Meter 4 input -			
19	n/c	SW meter		Input 5
7	Meter 5 input +			
20	Meter 5 input -			
8	n/c	RS meter		Input 6
21	Meter 6 input +			
9	Meter 6 input -			
22	n/c	unused		Input 7
10	Meter 7 input +			
23	Meter 7 input -			
11	n/c	unused		Input 8
24	Meter 8 input +			
12	Meter 8 input -			
25	n/c			
13	n/c			

Note. Connector only fitted if VU meter panel or RTW phasescope specified.

Phase Scope (Digital Circuits)				
Location:		Audio connector panel		
Connector Type:		25-way D-type female		
pin	Description		Notes: MSD600	Notes: RTW10830
1	Circuit 1	+	AES/EBU in 1/2	AES/EBU out 7/8*
14	Circuit 1	-		
2	n/c			
15	Circuit 2	+	AES/EBU in 3/4	AES/EBU out 5/6*
3	Circuit 2	-		
16	n/c			
4	Circuit 3	+	AES/EBU in 5/6	AES/EBU out 3/4*
17	Circuit 3	-		
5	n/c			
18	Circuit 4	+	unused	AES/EBU out 1/2*
6	Circuit 4	-		
19	n/c			
7	Circuit 5	+	unused	AES/EBU in 7/8
20	Circuit 5	-		
8	n/c			
21	Circuit 6	+	unused	AES/EBU in 5/6
9	Circuit 6	-		
22	n/c			
10	Circuit 7	+	unused	AES/EBU in 3/4
23	Circuit 7	-		
11	n/c			
24	Circuit 8	+	unused	AES/EBU in 1/2
12	Circuit 8	-		
25	n/c			
13	n/c			

* Output circuits are looped through from the corresponding input within the RTW meter.

Phase Scope (Diagnostics and Control)				
Location:		Audio connector panel		
Connector Type:		9-way D-type female		
pin			Notes: MSD600	Notes: RTW10830
1			Chassis	Switch common
6			n/c	Mode
2			Rx Data	Select
7			n/c	Memo
3			Tx Data	Gain
8			n/c	Reset
4			n/c	Shift
9			n/c	n/c
5			n/c	n/c

Note. Connectors only fitted if a phasescope is specified.
Refer to manufacturer's own manual for diagnostic information and operating instructions.

Connector Pinouts – Centuri Processor

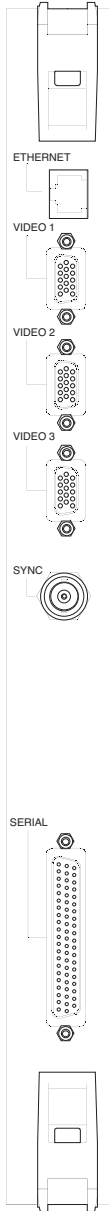

Video		
Location:		Centuri – CPU Card
Connector Type:		HDI5 female
pin	Description	Notes:
1	Red	
2	Green	
3	Blue	
4	ID bit	
5	n/c	
6	Red screen	
7	Green screen	
8	Blue screen	
9	n/c	
10	Ground	
11	ID bit	
12	ID bit	
13	H sync	
14	V sync	
15	n/c	

Serial (62pin to 8 off 9-pin breakout lead)									
Location:		Centuri – CPU card							
Connector Type:		62-way high-density D-type female							
D9-pin	Description	TTY-A	TTY-B	TTY-C	TTY-D	TTY-E	TTY-F	TTY-G	TTY-H
1	0V	7	28	14	52	21	42	35	59
6	0V	5	26	12	50	19	40	33	57
2	Rx Data L	2	23	9	47	16	37	30	54
7	Rx Data H	3	24	10	48	17	38	31	55
3	Tx Data H	2	22	8	46	15	36	29	53
8	Tx Data L	4	25	11	49	18	39	32	56
4	0V	6	27	13	51	20	41	34	58
9	n/c	-	-	-	-	-	-	-	-
5	0V	43	45	44	44	62	61	60	61

TTY A – H			
Location:		Centuri CPU serial breakout adapter lead	
Connector Type:		9-way D-type male (8 off)	
pin	Con. A–E, F–H (RS422)	Con. E (RS232)	Notes:
1	0V	0V	
6	0V	0V	
2	Rx Data L	Tx Data	
7	Rx Data H	0V	
3	Tx Data H	Rx Data	
8	Tx Data L	n/c	
4	0V	n/c	
9	n/c	n/c	
5	0V	0V	

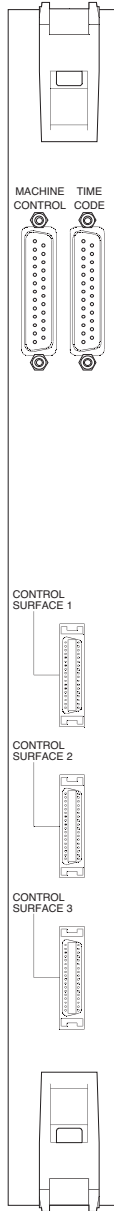

Timecode		
Location:		Centuri – Console interface card
Connector Type:		25-way D-type male
pin	Description	Notes:
1	in 1 +	
14	in 1 -	
2	in 1 gnd	
15	in 2 +	
3	in 2 -	
16	in 2 gnd	
4	in 3 +	
17	in 3 -	
5	in 3 gnd	
18	in 4 +	
6	in 4 -	
19	in 4 gnd	
7	unused	
20	out 1 +	
8	out 1 -	
21	out 1 gnd	
9	out 2 +	
22	out 2 -	
10	out 2 gnd	
23	out 3 +	
11	out 3 -	
24	out 3 gnd	
12	out 4 +	
25	out 4 -	
13	out 4 gnd	

Machine Control		
Location:		Centuri – Console interface card
Connector Type:		25-way D-type female
pin	Description	Notes:
1	n/c	
14	n/c	
2	Tally common	<i>Tally voltage can be AC or DC 4V to 30V.</i>
15	Switch common	
3	Rewind switch	
16	Rewind tally	
4	Forward switch	
17	Forward tally	
5	Stop switch	
18	Stop tally	
6	Play switch	
19	Play tally	
7	Skip back switch	
20	Skip back tally	
8	Record switch	
21	Record tally	
9	Tach 1	
22	Tach 2	
10	Dir 1	
23	Dir 2	
11	n/c	
24	n/c	
12	n/c	
25	n/c	
13	n/c	

Mic Input Card ('908)

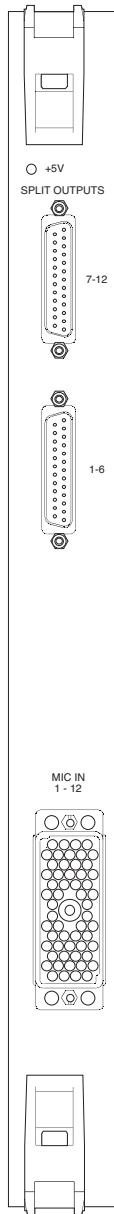

MIC In 1 – 12				
Location:		908 Micamp		
Connector Type:		Varicon 56-way female		
Cct	Hot	Cold	Screen	Notes
1	D	K	P	<i>All other pins unused</i>
2	C	J	N	
3	A	E	L	
4	B	F	M	
5	V	Z	d	
6	U	Y	c	
7	R	W	a	
8	S	X	b	
9	n	t	y	
10	m	s	x	
11	k	p	u	
12	l	r	v	

Split Outputs 1 – 6				
Location:		908 Micamp		
Connector Type:		25-way D-type female		
Cct	Hot	Cold	Screen	Notes
1	24	12	25	<i>Pin 13 unused</i>
2	10	23	11	
3	21	9	22	
4	7	20	8	
5	18	6	19	
6	4	17	5	

Split Outputs 7 – 12				
Location:		908 Micamp		
Connector Type:		25-way D-type female		
Cct	Hot	Cold	Screen	Notes
7	24	12	25	<i>Pin 13 unused</i>
8	10	23	11	
9	21	9	22	
10	7	20	8	
11	18	6	19	
12	4	17	5	

Analogue I/O Card ('904)



Analogue In / Out				
Location:		904 Analogue Card		
Connector Type:		DL96 female		
Cct	Hot	Cold	Screen	Notes
1	A1	B1	C1	<i>all other pins unused</i>
2	A2	B2	C2	
3	A3	B3	C3	
4	A4	B4	C4	
5	A5	B5	C5	
6	A6	B6	C6	
7	A7	B7	C7	
8	A8	B8	C8	
9	D1	E1	F1	
10	D2	E2	F2	
11	D3	E3	G1	
12	D4	E4	G2	
13	D5	E5	G7	
14	D6	E6	G8	
15	D7	E7	F7	
16	D8	E8	F8	
17	L1	K1	J1	
18	L2	K2	J2	
19	L3	K3	H1	
20	L4	K4	H2	
21	L5	K5	H7	
22	L6	K6	H8	
23	L7	K7	J7	
24	L8	K8	J8	

Digital I/O Card (*902)

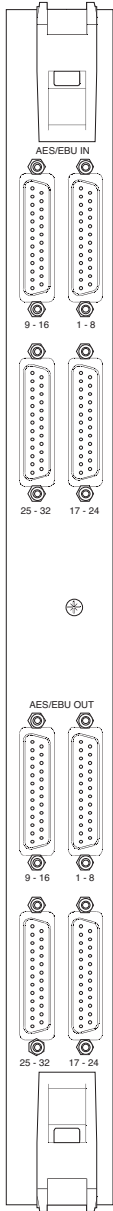

AES/EBU In 1-8 (9-16, 17-24, 25-32)				
Location:		902 DIO		
Connector Type: 25-way D-type female				
Cct	Hot	Cold	Screen	Notes
1	24	12	25	<i>Pin 13 unused</i>
2	10	23	11	
3	21	9	22	
4	7	20	8	
5	18	6	19	
6	4	17	5	
7	15	3	16	
8	1	14	2	

AES/EBU Out 1-8 (9-16, 17-24, 25-32)				
Location:		902 DIO		
Connector Type: 25-way D-type female				
Cct	Hot	Cold	Screen	Notes
1	24	12	25	<i>Pin 13 unused</i>
2	10	23	11	
3	21	9	22	
4	7	20	8	
5	18	6	19	
6	4	17	5	
7	15	3	16	
8	1	14	2	

BNC Breakout Panel

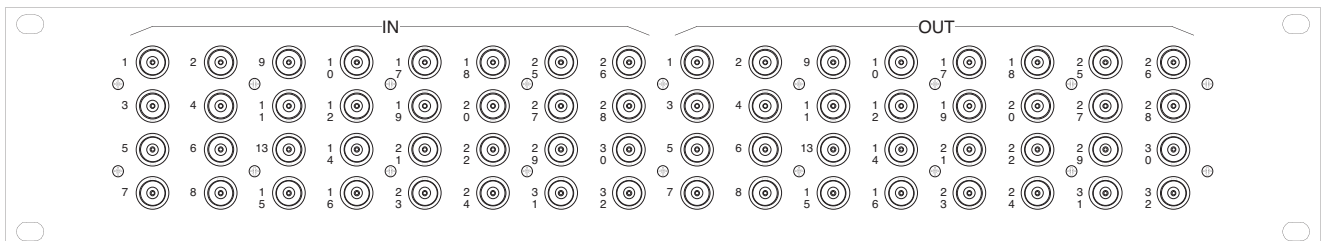

GPI I/O Card (‘907)

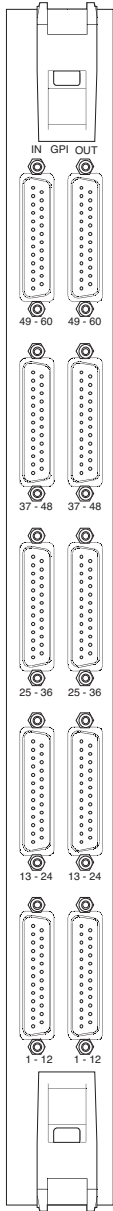

GPI Inputs 1–12 (13–24, 25–36, 37–48, 49–60)

Location: Centuri – Relay card

Connector Type: 25-way D-type male

pin	Description	Notes:
1	Input 1A	
14	Input 1B	
2	Input 2A	
15	Input 2B	
3	Input 3A	
16	Input 3B	
4	Input 4A	
17	Input 4B	
5	Input 5A	
18	Input 5B	
6	Input 6A	
19	Input 6B	
7	Input 7A	
20	Input 7B	
8	Input 8A	
21	Input 8B	
9	Input 9A	
22	Input 9B	
10	Input 10A	
23	Input 10B	
11	Input 11A	
24	Input 11B	
12	Input 12A	
25	Input 12B	
13	0V	

GPI Outputs 1–12 (13–24, 25–36, 37–48, 49–60)

Location: Centuri – Relay card

Connector Type: 25-way D-type female

pin	Description	Notes:
1	Output 1A	
14	Output 1B	
2	Output 2A	
15	Output 2B	
3	Output 3A	
16	Output 3B	
4	Output 4A	
17	Output 4B	
5	Output 5A	
18	Output 5B	
6	Output 6A	
19	Output 6B	
7	Output 7A	
20	Output 7B	
8	Output 8A	
21	Output 8B	
9	Output 9A	
22	Output 9B	
10	Output 10A	
23	Output 10B	
11	Output 11A	
24	Output 11B	
12	Output 12A	
25	Output 12B	
13	+15V	450mA across all connectors

Connector Pinouts – NetBridge

Serial 1–8 (RS232)		
Location:		Netbridge – Rear panel
Connector Type:		9-way D-type male
pin	Description	Notes:
1	Chassis	
6	n/c	
2	Rx Data	
7	n/c	
3	Tx Data	
8	n/c	
4	n/c	
9	n/c	
5	0V	

Terminal (RS232)		
Location:		Netbridge – Rear panel
Connector Type:		9-way D-type male
pin	Description	Notes:
1	DCD	Data Carrier Detect
6	DSR	Data Set Ready
2	Rx Data	
7	RTS	Request To Send
3	Tx Data	
8	CTS	Clear To Send
4	DTR	Data Terminal Ready
9	RI	Ring Indicator
5	Signal ground	

NetBridge Diagnostic Cable

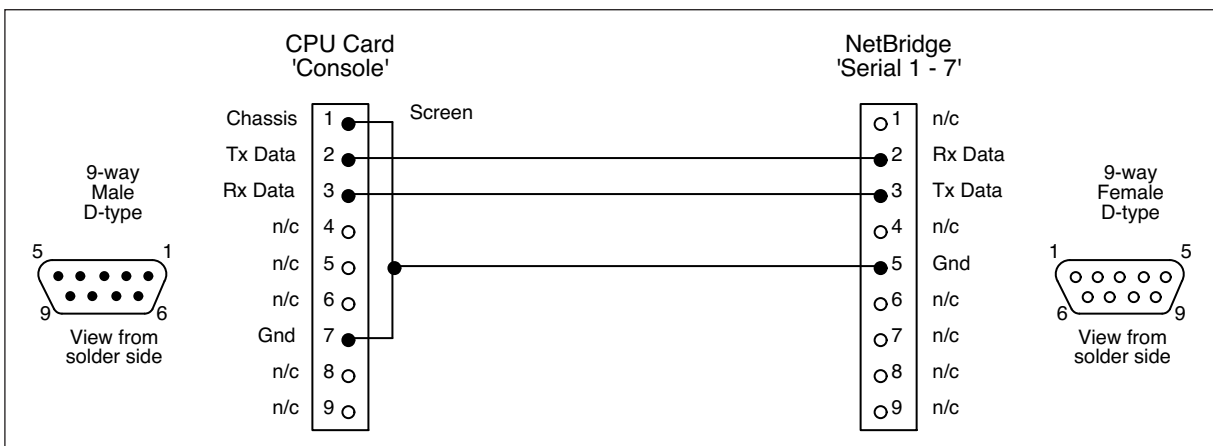

Resistor Colour Code:

<i>Black</i>	<i>0</i>
<i>Brown</i>	<i>1</i>
<i>Red</i>	<i>2</i>
<i>Orange</i>	<i>3</i>
<i>Yellow</i>	<i>4</i>
<i>Green</i>	<i>5</i>
<i>Blue</i>	<i>6</i>
<i>Violet</i>	<i>7</i>
<i>Grey</i>	<i>8</i>
<i>White</i>	<i>9</i>

Appendix D: Audio Interfacing

All analogue audio inputs and outputs are electronically balanced. The screen pins are all directly connected to the chassis at the point of entry to comply with AES/EBU grounding and EMC recommendations.

Balanced Circuits

It is strongly recommended that balanced connections are used wherever possible using high quality screened cable. The following diagram shows the recommended connection with both screens connected to the chassis:

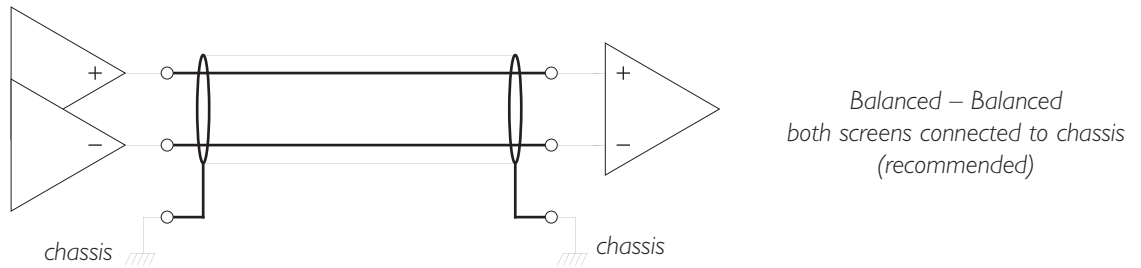

On some older items of equipment the screen connection may still be referenced to the circuit 0V rather than the chassis. In these cases it may be advantageous to disconnect the screen at this connection. Note however that this practice will degrade the EMC performance.

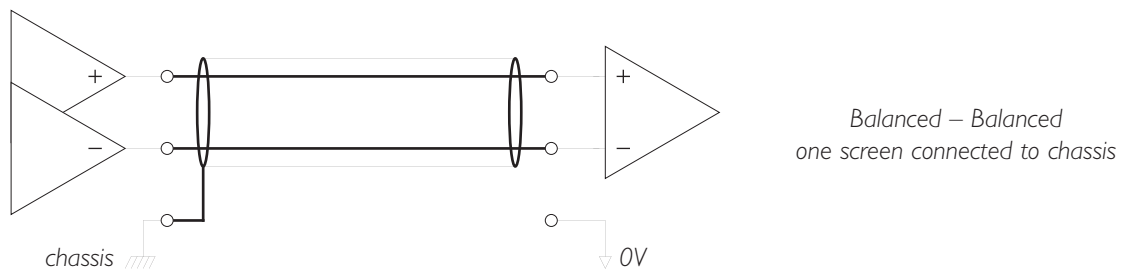

Connecting to Unbalanced Equipment

Connecting to unbalanced equipment can be much more problematic. It is much more likely that earth and induced RF currents will become referenced to the audio 0V which will give rise to audible hum and buzz.

The recommendation for connection of balanced to unbalanced equipment is to isolate unbalanced connections by using a balancing transformer.

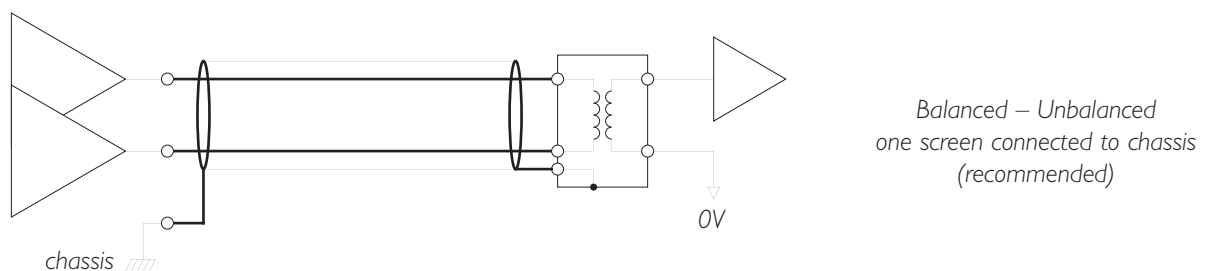

1 inch = 25.4mm (exactly)
1 m = 3' 3" (roughly)
1 mile = 1,600m (roughly)
1 Kg = 2.2 Pounds (roughly)

Appendix E: Environmental Specification

Temperature	Operating:	5 to 30 Deg. C
	Non-operating:	-20 to 50 Deg. C
	Max. Gradient:	15 Deg. C/Hour
Relative Humidity	Operating:	20 to 80 %
	Non-operating:	5 to 90 %
	Max. wet bulb:	29 Deg. C (non-condensing)
Vibration	Operating:	< 0.2 G (3 - 100Hz.)
	Non-operating, power off:	< 0.4 G (3 - 100Hz.)
Shock	Operating:	< 2 G (10mSec. Max.)
	Non-operating:	< 10 G (10mSec. Max.)
Altitude (above sea level)	Operating:	0 to 3000 m
	Non-operating:	0 to 12000 m

+4dBu = 1.229V rms.

0dBu = 0.775V rms.

-6dBu = 0.388V rms.

Appendix F: Additional Information for Installing Stageboxes

When positioning and installing a C-SB the following rules must be followed:

- Unobstructed airflow at front and rear.
- No obstruction to airflow, horizontally or vertically, within 300mm in front, above and below both the front and rear panels.
- Ambient temperature no more than 30°C measured at the air intake (lower front opening) or just below the rear heatsink.
- Microphone cables must not obstruct the air intake. To help ensure this, a cable guide is provided down the sides of the rack.

Design Requirements for a Flightcase

If a Stagebox is to be installed into a flight case the following requirements, in addition to those above, must be met to ensure adequate passive cooling – otherwise user must install a ‘forced-ventilation kit’ option.

- Both front and rear covers must be completely removed during operation.
- The front and rear covers must be deep enough to ensure that the front and rear faces of Stagebox are flush with front and rear of the open flight case.

Appendix G: C300HD Machine Control

Overview

C300HD features a comprehensive multi-port serial machine controller, a timecode reader and a virtual machine timecode generator locked to the system master timeline, running synchronously at the system reference frequency. Both the timecode reader and generator support 'stationary' timecode.

Two primary modes of operation are supported – multi machine synchronous control where each connected machine resolves to a common sync reference at play speed, and asynchronous single machine control where the controlled machine uses a local/internal reference for speed control with linear play speed timecode as the positional reference for the 'desk' timeline.

Machines can be addressed using serial (RS422) control, direct HUI (MIDI) control, or legacy style parallel control with a maximum of four devices online at any one time for synchronous operation, or a single device for asynchronous operation. The Centuri core features a timecode reader with four switchable inputs, and LTC and MTC timecode generators, which are locked to the designated 'desk' master position in all synchronous operating modes.

Asynchronous operation is supported in a timecode only chase system or via the DCTM (Direct Control of Tape Machine) port, and requires continuous LTC from the master device at play speed.

The primary interface for control of external machines is the set of transport control buttons on the Automation and Motion Control panel that allow any online machine (and the desk) to be put into play, record, fast-forward, rewind, etc. A rotary encoder 'wheel', located next to the transport controls, can send true jog and shuttle commands to 9-pin controlled devices, or can control the desk's built in 'virtual machine' in comparable modes.

Primary Machine Control Options

Sony 9-Pin

controls machines using the Sony 'P2' RS422 remote protocol, including track arming support. This can be used with video machines, DAT and MDM recorders which support 9-pin control, as well as disk-based workstations and recorders such as Pro Tools, Nuendo, Radar, Sadie, Pyramix and Fairlight, which all have 9-pin emulation. Up to four machines may be synchronised simultaneously using Sony 9-pin with either a nominated serial machine or the 'desk' as the system master.

On Slave devices selecting 'LTC Chase ON' from the port set up menu enables the controlled device's internal timecode synchroniser in Play and defeats slewing the device into lock via serial 'Varispeed' commands. This is normally the recommended approach to controlling DAWs as slaves whilst retaining control of Track arming and Master Record from the C300HD front panel.

It is mandatory that all controlled serial machines are set up for 'Ext Video Sync' operation using a video reference from a suitable house sync generator and with the 'SYNC PLAY' option enabled if applicable (which is the case for the majority of machines except VTRs). This rule is particularly important for digital audio recorders.

Indirect control of machines may also be achieved via third-party machine control systems such as units from Soundmaster, CB Electronics and Tamura; all have a control port, which emulates a single 9-pin machine.

LTC Slave

The desk follows play speed timecode from a locally controlled machine. Supports the MMC (Midi Machine Control) locate commands to follow positional changes from machines, primarily DAWs, which only output play speed timecode. MIDI Port 12 must be used to receive MMC locates.

Additional Machine Control options

Sony/LTC

Uses LTC as the positional reference for a Sony 9-pin controlled Master machine instead of the data reported via the 9-Pin link. Used primarily for the control of DAWs that have problems reporting position via a serial interface, or for setting up a system where all slave machines chase LTC from the designated master machine. Supports the same tracking arming and record capabilities as Sony 9-Pin and the same MMC option as the LTC Slave option.

Sony Slave

The port emulates a device operating under Sony 9-pin control. Two modes of operation are possible:

- The controlling device outputs basic transport commands and locks to the desk position returned from the Sony Slave port.
- The controlling device synchronises the desk position to its own internal timeline.

The first mode is suitable for DAWs that have a 9-pin port capable of controlling a machine (as opposed to emulating a 9-pin machine) and provides advantages in parallel control but loses the ability to track arm the DAW. This mode supports additional Sony 9-pin machines on the remaining serial ports as well as a DCTM or a Sony/LTC master, as long as all the machines are set for synchronous operation.

Serial slave machines will not follow transport commands originated on the Master machine in this mode.

The second mode can be used to interface the desk to an external machine controller.

VPR3

Alternative RS422 9-pin control protocol used primarily with the legacy Timeline Lynx I/II synchronisers for parallel and bi-phase machine control. Also supports the JSK bi-phase controller. Only serial Port 4 supports VPR3 control of a single device. The connected device can be a master or slave.

DCTM

Parallel control of a tape machine or flim dubber using the five basic transport commands. Position is derived from timecode at play speed and via a tach pulse and direction tally in wind.

Timecode Generator

The C300 can generate video-referenced longitudinal (LTC), and MIDI (MTC) timecode, locked to the desk position in all synchronous serial machine control modes and when receiving video-locked timecode from a controlled device. The timecode output is not video referenced when regenerating code received from machines under asynchronous control, or not locked to the same reference as the C300 processor. With a synchronous master, the desk timecode output can be used as a master reference for external machines with built-in timecode chase synchronisers. All common timecode frame rates are supported (23.976, 24, 25, 29.97 DF and NDF, 30) provided the system is locked to the correct SD or HD video reference.

$$\text{volume of a sphere} = \frac{4 \pi r^3}{3}$$

Appendix H – Cables and Accessories - by Part Description

Description	SSL Part No.
Audio Cables and Accessories	
DL Connector Crimp Contacts .32MM LOOSE	32QFXXQ1
DL Connector Free Hood 96-way	32QF96FH
DL Connector Free Plug 96-way	32QF96KC
DL Connector Handle	32QFXXKM
DL Connector 96W Chassis Socket	32QF96GC
DL Connector Crimp Contact Removal Tool	80CLAGDC
DL Connector Crimp Tool	80CLAG1C
Lead DL - DL 24cct 10m	92DL1024
Lead DL - DL 24cct 15m	92DL1524
Lead DL - DL 24cct 20m	92DL2024
Lead DL - DL 24cct 25m	92DL2524
Lead DL - DL 32cct 10m	92DL1032
Lead DL - DL 32cct 15m	92DL1532
Lead DL - DL 32cct 20m	92DL2032
Lead DL - DL 32cct 25m	92DL2532
Processor & Machine cables	
25-way D-type to 9-way D-type RS232 10m	66C60002
RJ45 to 25-way D-type RS232 10m	66C67206
9-way D-type to 9-way D-type RS422 10m	66C60007
Network Cables	
Ethernet: RJ45 to RJ45 10baseT 0.5m (pin-pin)	66C67207
Ethernet: RJ45 to RJ45 10baseT 1m (pin-pin)	66C67210
Ethernet: RJ45 to RJ45 10baseT 2m (pin-pin)	66C67220
Ethernet: RJ45 to RJ45 10baseT 5m (pin-pin)	66C67250
Ethernet: RJ45 to RJ45 10baseT 10m (pin-pin)	66C67310
Ethernet: RJ45 to RJ45 10baseT 16m (pin-pin)	66C67316
Ethernet: RJ45 to RJ45 10baseT 20m (pin-pin)	66C67320
Ethernet: RJ45 to RJ45 10baseT 25m (pin-pin)	66C67325
Video & Sync	
Lead Video HD15 XGA 16m	66DN16V1
Lead Video HD15 XGA 20m	66DN20V1
Lead Video HD15 XGA 25m	66DN25V1
Lead Video HD15 XGA 48m	66DN48V1
BNC 75 'Y' piece	32TKU5DC
BNC 75 Terminator	32TKB7TC
Miscellaneous/Hardware	
25-way D-type Male-to-Female Cable 15m (audio)	66C90014
IEC Mains Lead	32VGL372
IEC Mains Lead (US)	32VGL3BN

Notes