



DOC NO : Preliminary 1.0

User Manual

CUSTOMER _____
PRODUCT 2.4GHz Wireless Digital Transceiver Module
MODEL NO. DRF-TR001(LW2110, LW2110PK2B)
DATE July. 2011

義聯科技股份有限公司
ELANsat Technologies Inc.
5F, No.12, Innovation Road I ,
Science-Based Industrial Park,
Hsin-chu, Taiwan, R.O.C.
TEL : +886-3-563-5105
FAX : +886-3-563-5107
[http : //www.elansat.com](http://www.elansat.com)
E-mail : sales@elansat.com
新竹科學園區創新一路12號5F

Features

- Auto ACK & retransmit
- On the air max. data rate 2Mbps
- Digital interface (SPI) speed 0~8 Mbps
- Software selectable channel from 2402MHz to 2478MHz (40 Selectable channels)
- Short switching time enable frequency hopping
- Power supply range: 3 V to 3.6 V
- Minimum number of external component
- Low power consumption: 3.3V, 30mA
- Transmission distance: 100 m (Line of sight)
- Outline: 23.2 x 20.8 x 4.3 mm
- 47 CFR Part 15 Subpart A Section 15.21

Applications

- Keyless Entry
- Wireless data communication
- Alarm and security systems – Wireless home security, Video Door Bell, Video door phone
- Home automation
- Surveillance – Wireless P-CAM, Video Baby Monitor
- Automotive – Wireless Vision-Based Robotic System, Automotive Accessory
- Telemetry
- Intelligent sports equipment, Video Rockie-Talkie
- Industrial sensors
- Toys – Camera Radio Controlled Toy
- Wireless Photo Frame

Benefits

- Ready for production
- Reduce time to market
- Remove complicity of RF design
- No RF experience require
- No expensive RF equipment require
- Plug and play
- No fuse on turning and trimming
- No need for expensive external antenna

Specification

Parameter	Limits			Unit
	MIN	TYP	MAX	
Power Section				
Supply Voltage	3	3.3	3.6	V
Supply Current in Tx mode	23	30	33	mA
Supply Current in Rx mode	17	18	19	mA
Digital Input Section				
High level input voltage	2.1		2.25	Vpp
Low level input voltage	0		1.08	Vpp
Digital Output Section				
High level output voltage	2.7		3.6	Vpp
Low level output voltage	0		0.3	Vpp
RF Section				
Frequency Range	2402	-	2478	MHz
Channel Bandwidth	1.8		2	MHz
TX Power	7.5	8.5	9.5	dBm
RX Sensitivity		-81		dBm
Operation				
Operating Temperature	-10	-	+60	°C

Pin Configuration and Mechanical Information

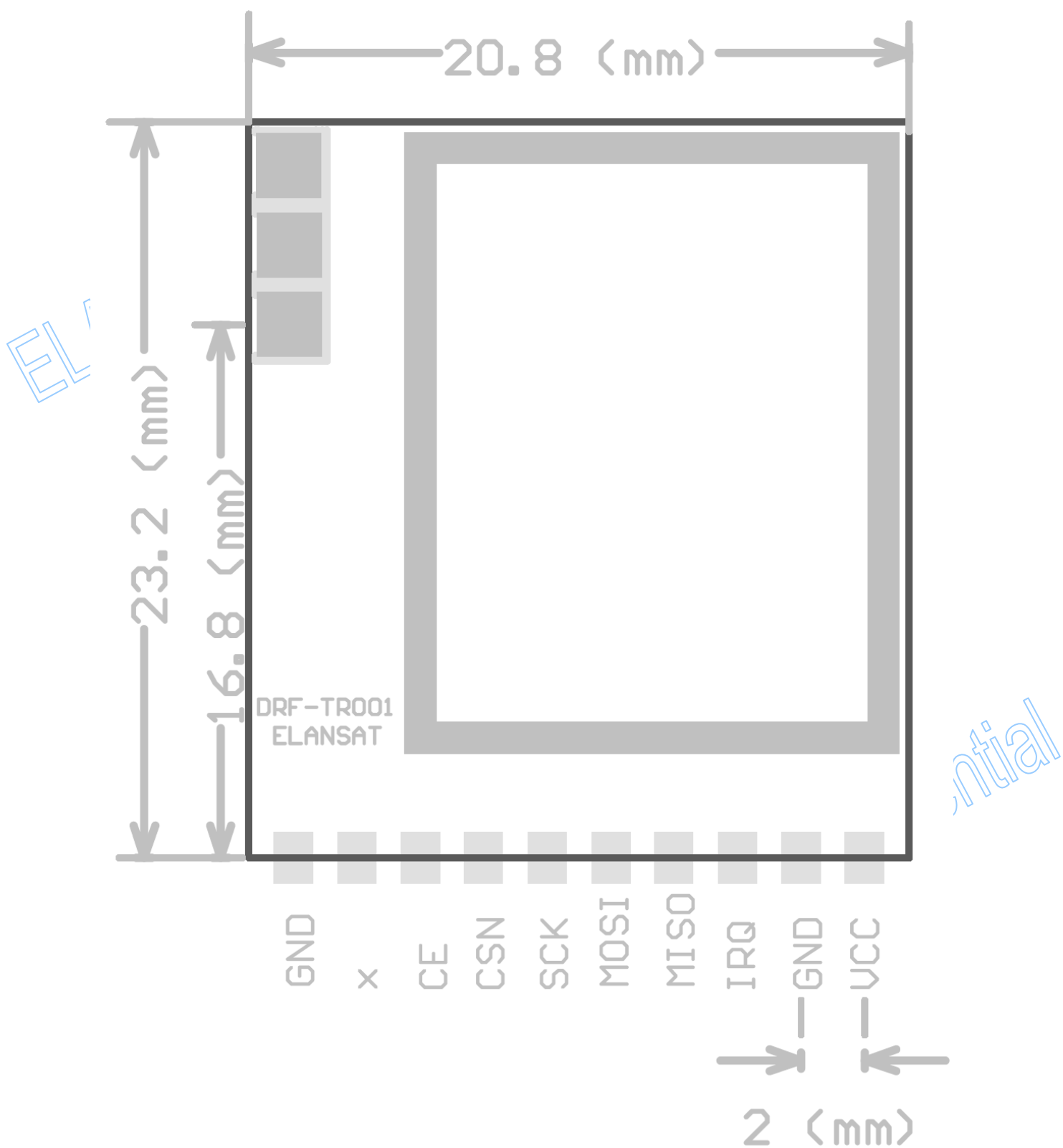

Pin Description

No.	Symbol	Function
1	VCC	Power Supply
2	GND	Ground
3	IRQ	Maskable interrupt pin
4	MISO	Master Input, Slave Output (output from slave)
5	MOSI	Master Output, Slave Input (output from master)
6	SCK	Serial Clock (output from master)
7	CSN	Chip Select
8	CE	Chip Enable Activates RX or TX mode
9	X	
10	GND	Ground

PCB layout guideline

Any metal (including PCB track and holding screw) around the antenna will result in changing impedance and radiation pattern of the antenna. These two parameters are the most important for antenna performance. Reserve space around the antenna as much as possible.

Connect all parts as close as possible to the pins of module and reduce the length of routing traces, to help on good audio performance, proper antenna pattern and EMC.

When designing the receiver module in wireless speakers and headphones, the important design considerations are as follows:

1. Keep metal objects away from the antenna by 3 cm distance at least to avoid degradation on the antenna. For example, speaker unit, transformer, adaptor, wire, cable and other big metal object beside antenna will degrade the antenna performance.
2. Use regulated DC-power-supply to the modules, and separate the DC-power-supply of module with the other circuits.

Antenna

1. Wire Antenna: A 27~31mm plastic-covered wire can be used as antenna. In principle, 31mm length is for a wire without any cover or very thin cover. The thicker of the cover, the shorter of the antenna length. Try various length for a certain wire to optimize the transmission distance.
2. Antenna Soldering:

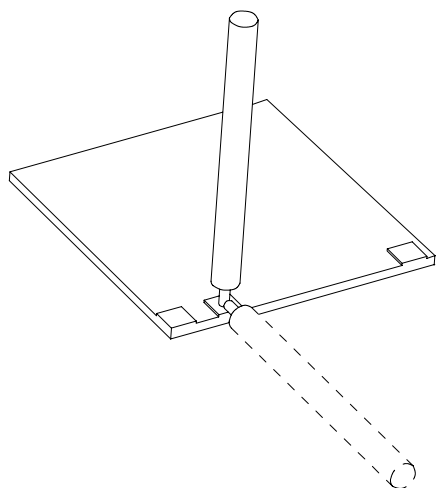

standrd equipment

Max. output of the antenna is 1.8 dBi

TYPE:C1073-510001-A(SSR-80521)

Operation

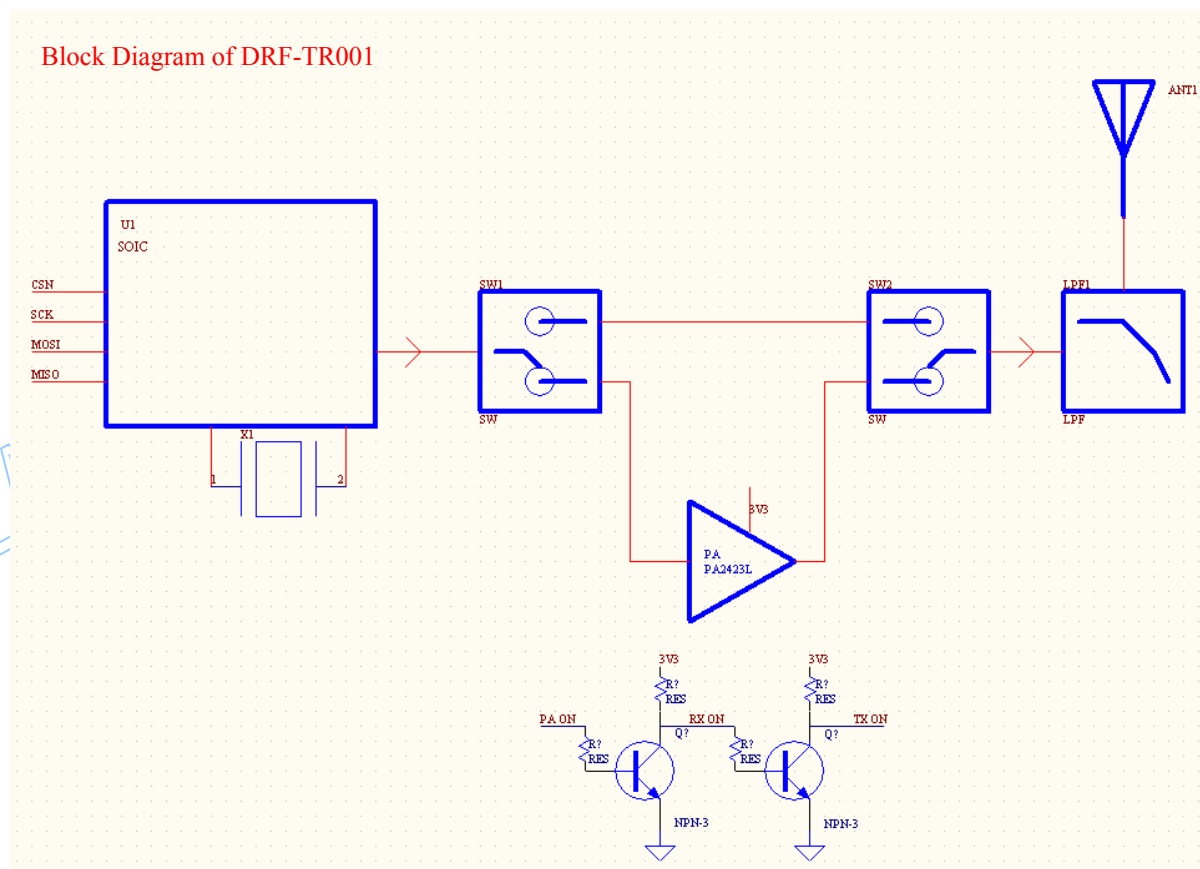

The SPI data then is fed to SOIC for encoding, FSK-modulation, frequency conversion, and amplification.

RF signal between SOIC and antenna is separated to two paths: transmission and receiving (by two RF switches). Transmitted RF Signal from SOIC is following by a power amplifier to increase output power and transmission distance.

RF signal between SOIC and antenna is separated to two paths: transmission and receiving (by two RF switches). Transmitted RF Signal from SOIC is following by a power amplifier to increase output power and transmission distance.

FCC Transmitter Notice:

This equipment has been certified and found to comply with the limits regulated by the FCC 47 CFR part15, subpart A Section 15.21.

You are cautioned that changes or modifications not expressly approved by the part responsible for compliance could void the user's authority to operate the equipment.

This device complies with Part 15 of FCC Rules and RSS-Gen of IC Rules.

Operation is subject to the following two conditions:

- 1) This device may not cause harmful interference, and
- 2) This device must accept any interference received, including interference that may cause undesired operation.

Note: This equipment contains module, FCC ID: UCZM2110 and IC: 8575A-LW2110 which qualifies as an UNLICENSED MODULAR TRANSMITTER per FCC Public Notice DA 00-1407 and RSS-Gen Section: 7.1.1. It has been tested and found to comply with Part 15.247 of the FCC Rules and RSS-210 issue 8 : 2010 Annex 8

Required labeling.

Any device incorporating this module must include an external, visible, permanent marking or label which states:

*Contains FCC ID: UCZM2110

*Contains IC: 8575A-LW2110

Failure to comply with this requirement will void the user's authority to operate any device that incorporates this module.

This equipment complies with FCC/IC radiation exposure limits set forth for uncontrolled equipment and meets the FCC radio frequency (RF) Exposure Guidelines in Supplement C to OET65 and RSS-102 of the IC radio frequency (RF) Exposure rules. This equipment has very low levels of RF energy that it is deemed to comply without testing of specific absorption ratio (SAR).

To reduce potential radio interference to other users, the antenna type and its gain should be so chosen that the equivalent isotropically radiated power (e.i.r.p.) is not more than that permitted for successful communication.

Under Industry Canada regulations, this radio transmitter may only operate using an antenna of a type and maximum (or lesser) gain approved for the transmitter by Industry Canada. To reduce potential radio interference to other users, the antenna type and its gain should be so chosen that the equivalent isotropically radiated power (e.i.r.p.) is not more than that necessary for successful communication.

This radio transmitter (identify the device by certification number, or model number if Category II) has been approved by Industry Canada to operate with the antenna types listed below with the maximum permissible gain and required antenna impedance for each antenna type indicated. Antenna types not included in this list, having a gain greater than the maximum gain indicated for that type, are strictly prohibited for use with this device.

This device complies with Industry Canada licence-exempt RSS standard(s). Operation is subject to the following two conditions: (1) this device may not cause interference, and (2) this device must accept any interference, including interference that may cause undesired operation of the device.