



**LOREX**<sup>®</sup>  
VIEW YOUR WORLD<sup>®</sup>

# 10X PAN-TILT-ZOOM CAMERA

## Instruction Manual

English Version 4.0



**RETAIL**



**INDUSTRY**



**BUSINESS**



**HOME**



**OUTDOOR**

[www.lorextechnology.com](http://www.lorextechnology.com)

Copyright © 2013 Lorex Technology Inc.

**VANTAGE**

**LZC7091**



Thank you for purchasing the LOREX Super+ Resolution 10X PTZ Speed-Dome Camera.

This manual refers to the following models:

- LZC7091

For the latest online manual and to learn about our complete range of accessory products, please visit our website at:

[www.lorextchnology.com](http://www.lorextchnology.com)

	<b>CAUTION</b> RISK OF ELECTRIC SHOCK DO NOT OPEN DURING OPERATION	
CAUTION: NO USER SERVICABLE PARTS INSIDE. REFER SERVICING TO QUALIFIED SERVICE PERSONNEL.		



The lightning flash with arrowhead symbol, within an equilateral triangle, is intended to alert the user to the presence of uninsulated "dangerous voltage" within the products' enclosure that may be of sufficient magnitude to constitute a risk of electric shock.



The exclamation point within an equilateral triangle is intended to alert the user to the presence of important operating and maintenance (servicing) instructions in the literature accompanying the appliance.

**CAUTION: TO PREVENT ELECTRIC SHOCK, MATCH WIDE BLADE OF THE PLUG TO THE WIDE SLOT AND FULLY INSERT.**



**NEED HELP?**

**CONTACT US FIRST**

**DO NOT RETURN THIS PRODUCT TO THE STORE**

Please make sure to register your product at [www.lorextechnology.com](http://www.lorextechnology.com) to receive product updates and technical support.

## 2 Easy Ways to Contact Us



### Online:

Product Support is available 24/7 including product information, user manuals, quick start up guides and FAQ's at [www.lorextechnology.com/support](http://www.lorextechnology.com/support)

For all other matters, visit [www.lorextechnology.com](http://www.lorextechnology.com)



### By Phone:

North America:

Customer Service (for warranty matters): **1-888-425-6739** (1-888-42-LOREX)

Tech Support (for technical/installation issues): **1-877-755-6739** (1-877-75-LOREX)

Mexico: **001-800-681-9263, 001-800-514-6739**

International: **+800-425-6739-0** (Example: From the UK, dial 00 instead of +)



VIEW YOUR WORLD™  
VOIR VOTRE MONDE™  
VEA SU MUNDO™

LIVE VANTAGE



## ¿NECESITA AYUDA?

COMUNÍQUESE PRIMERO  
CON NOSOTROS

## BESOIN D'ASSISTANCE?

COMMUNIQUEZ D'ABORD  
AVEC NOUS

**NO DEVUELVA ESTE PRODUCTO A LA TIENDA**

Por favor, registre su producto en [www.lorextechnology.com](http://www.lorextechnology.com) para recibir actualizaciones del producto y asistencia técnica.

Hay 2 maneras fáciles de comunicarse con nosotros:

### En línea:

Apoyo al cliente está disponible 24/7, incluyendo información del producto, manuales para el usuario, guías de inicio rápido y preguntas más frecuentes en:

[www.lorextechnology.com/support](http://www.lorextechnology.com/support)

Para todo lo demás, visite

[www.lorextechnology.com](http://www.lorextechnology.com)

### Por teléfono:

Norte América:

Atención al cliente (para asuntos de la garantía - garantía válida sólo en E.U.A., vea la garantía ofrecida por el importador):

**1-888-425-6739** (1-888-42-LOREX)

Asistencia técnica (para asuntos técnicos o de instalación):

**1-877-755-6739** (1-877-75-LOREX)

Teléfono y Servicios Válidos Sólo en E.U.A.:

**001-800-681-9263, 001-800-514-6739**

Internacional: **+800-425-6739-0**

**NE RETOURNEZ PAS CE PRODUIT AU MAGASIN**

Veuillez enregistrer votre produit sur le site [www.lorextechnology.com](http://www.lorextechnology.com) afin de recevoir des mises à jour et le soutien technique pour votre produit.

2 façons simples de communiquer avec nous :

### En ligne :

À votre disposition 24/7, le soutien pour les produits comprend les renseignements sur les produits, guides d'utilisation, guides de départ rapide et FAQ :

[www.lorextechnology.com/support](http://www.lorextechnology.com/support)

Pour toutes les autres questions,

visitez [www.lorextechnology.com](http://www.lorextechnology.com)

### Par téléphone :

En Amérique du Nord :

Service à la clientèle (pour tout ce qui concerne la garantie) :

**1-888-425-6739** (1-888-42-LOREX)

Soutien technique (pour les questions d'ordre technique ou relatives à l'installation) : **1-877-755-6739** (1-877-75-LOREX)

Mexique : **001-800-681-9263, 001-800-514-6739**

International : **+800-425-6739-0**

(par exemple : à partir du Royaume-Uni, composez le 00 au lieu de +)

# BEFORE YOU START

Please make sure to register your product at [www.lorextechnology.com](http://www.lorextechnology.com) to receive product updates and technical support

THIS PRODUCT MAY REQUIRE PROFESSIONAL INSTALLATION

**LOREX IS COMMITTED TO FULFILLING YOUR SECURITY NEEDS**



- We have developed user friendly products and documentation. Please read the Quick Start Guide and User Manual before you install this product.

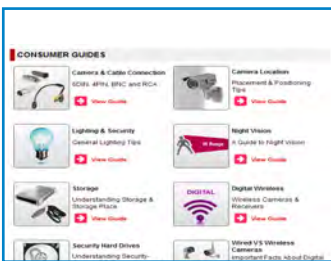

- Consumer Guides and Video Tutorials are available on our web site at [www.lorextechnology.com/support](http://www.lorextechnology.com/support)



- If you require further installation assistance, please visit [www.lorextechnology.com/installation](http://www.lorextechnology.com/installation) or contact a professional installer.



- Please note that once the components of this product have been unsealed, you cannot return this product directly to the store without the original packaging.



# AVANT DE COMMENCER

Veillez enregistrer votre produit sur le site [www.lorextechnology.com](http://www.lorextechnology.com) afin de recevoir des mises à jour et le soutien technique pour votre produit.

CE PRODUIT PEUT NÉCESSITER UNE INSTALLATION PROFESSIONNELLE

LOREX S'ENGAGE À RÉPONDRE À VOS BESOINS EN MATIÈRE DE SÉCURITÉ

- Nous avons conçu et développé une documentation et des produits extrêmement conviviaux. Veillez lire le Guide de départ rapide et le Guide d'utilisation avant d'installer ce produit.
- Des guides pour consommateurs et des tutoriels vidéo vous sont offerts sur notre site Web : [www.lorextechnology.com/support](http://www.lorextechnology.com/support)
- Si vous avez besoin de plus d'assistance pour l'installation de ce produit, veuillez visiter le site [www.lorextechnology.com/installation](http://www.lorextechnology.com/installation) ou communiquez avec un installateur professionnel.
- Veillez prendre note que lorsque vous avez déballé les pièces et composantes de ce produit, vous ne pouvez pas retourner celui-ci directement au magasin sans son emballage original.

# ANTES DE EMPEZAR

Cerciórese de por favor colocar su producto en [www.lorextechnology.com](http://www.lorextechnology.com) para recibir actualizaciones y la información del producto y soporte técnico.

ESTE PRODUCTO PUEDE EXIGIR UNA INSTALACIÓN PROFESIONAL

LOREX SE COMPROMETE A SATISFACER SUS NECESIDADES EN SEGURIDAD

- Favor de leer la guía de instalación rápida y la guía del usuario antes de instalar este producto.
- Puede conseguir las guías del consumidor y los cursos en enseñanza video sobre el Internet visitando [www.lorextechnology.com/support](http://www.lorextechnology.com/support)
- Si necesita ayuda para la instalación, visite [www.lorextechnology.com/installation](http://www.lorextechnology.com/installation) o contacte un especialista en instalaciones.
- Favor de notar que una vez que los componentes de este producto han sido removidos del embalaje, no podrá devolver este producto directamente a la tienda.



[www.lorextechnology.com](http://www.lorextechnology.com)



**LOREX**<sup>®</sup>

VIEW YOUR WORLD™  
VOIR VOTRE MONDE™  
VEA SU MUNDO™

**VANTAGE**

---

# Features

- Latest Sony EXview™ II image sensor for best-in-class low light performance<sup>1</sup>
- Sony Effio™ video image processor delivers up to 700TV lines of resolution
- 10X Optical Zoom and 10X Digital Zoom to focus in on even the finest details
- Complete area coverage with 360 degrees per second panning speed
- Program preset viewing points when connected to a DVR
- ClearNight technology with Digital Noise Reduction improves low light performance and recording efficiency by up to 30%
- Accurate colors with Lorex's automatic light filtering technology
- Weatherproof (IP66) rated using included wall mount<sup>2</sup>
- Connects to any Lorex Eco™ or Edge™ series DVR for local or remote operation
- Removable camera base for easier and safer installation
- 100ft all-in-one extension cable included for installation location flexibility

As our products are subject to continuous improvement, Lorex reserves the right to modify product design, specifications and prices, without notice and without incurring any obligation. E&OE

<sup>1</sup> This camera features an ultra-low light sensitive image sensor and therefore does not feature Infra-Red LEDs. The camera requires ambient lighting (for example, street/building lighting, star or moon light) to render a night time image. In total darkness (zero Lux) the camera will not produce a night time image and therefore the camera should not be installed in completely dark areas.

<sup>2</sup> Wall mount required for outdoor installation. Not intended for submersion in water. Installation in a sheltered location recommended.

---

# Safety Instructions

- Read this guide carefully and keep it for future reference.
- Follow all instructions for safe use of the product and handle with care.
- Use the camera within given temperature, humidity, and voltage levels noted in the Technical Specifications.
- Camera is rated for outdoor use and is weatherproof using included wall mount only. For indoor installations, camera may be directly attached to a ceiling.
- Camera is not intended for submersion in water. Installation under a sheltered environment is recommended.
- Do not disassemble the camera.
- Do not point the camera directly towards the sun or a source of intense light.
- Use only the supplied regulated power supply. Use of a non-regulated, non-conforming power supply can damage this product and voids the warranty.
- Make sure to install the camera in a location that can support the camera weight.
- Make sure there are no live electrical cables in the area where you plan to mount the camera.
- Periodic cleaning may be required. Use a damp cloth only. Do not use anything other than water to clean the dome cover, as chemicals such as acetone can permanently damage the plastic.



---

# TABLE OF CONTENTS

<b>1. Getting Started</b> .....	<b>1</b>
<b>2. Connecting the Camera</b> .....	<b>2</b>
2.1 Default Protocol Information .....	6
<b>3. Installation</b> .....	<b>7</b>
3.1 Installation Tips and Warnings .....	7
3.2 Extension Cables .....	8
3.3 Wall Mount Installation (Indoor/Outdoor) .....	9
3.4 Ceiling Install (Indoor Only) .....	12
<b>4. Controlling the PTZ Camera with your DVR</b> .....	<b>16</b>
4.1 Initial Setup .....	16
4.2 Controlling the Camera .....	17
4.3 PTZ Presets and PTZ Cruise .....	19
4.4 Setting PTZ Presets on the ECO2 DVR .....	19
4.5 Selecting PTZ Presets on the ECO2 DVR .....	20
4.6 Deleting PTZ Presets on the ECO2 DVR .....	20
4.7 Starting / Stopping PTZ Cruise on the ECO2 DVR .....	20
<b>5. Changing Protocol Information</b> .....	<b>21</b>
5.1 Accessing the DIP Switches .....	22
5.2 Setting the Camera ID .....	22
5.3 Setting the Camera Protocol and Baud Rate .....	24
<b>6. Technical Specifications</b> .....	<b>25</b>
<b>7. Dimensions</b> .....	<b>26</b>
<b>8. Troubleshooting</b> .....	<b>27</b>

---

# 1. GETTING STARTED

Before you start, ensure you have received all the items listed below:



**Camera**



**3ft BNC/Power/RS485 Cable**



**100ft BNC/Power/RS485  
Extension Cable**

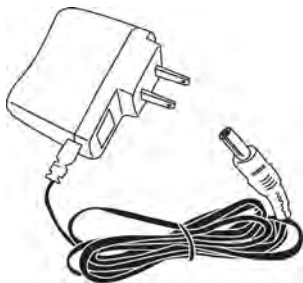

**13V DC Power Adapter**



**Mounting Screw Kit**



**Instruction Manual**

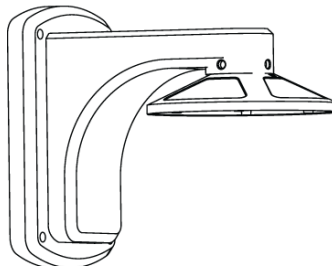

**Wall Mount Kit**

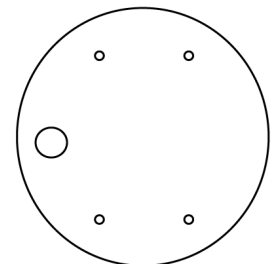

**Foam Pad**

## 2. CONNECTING THE CAMERA



It is recommended to connect the camera to your DVR and test the PTZ controls before permanent installation.

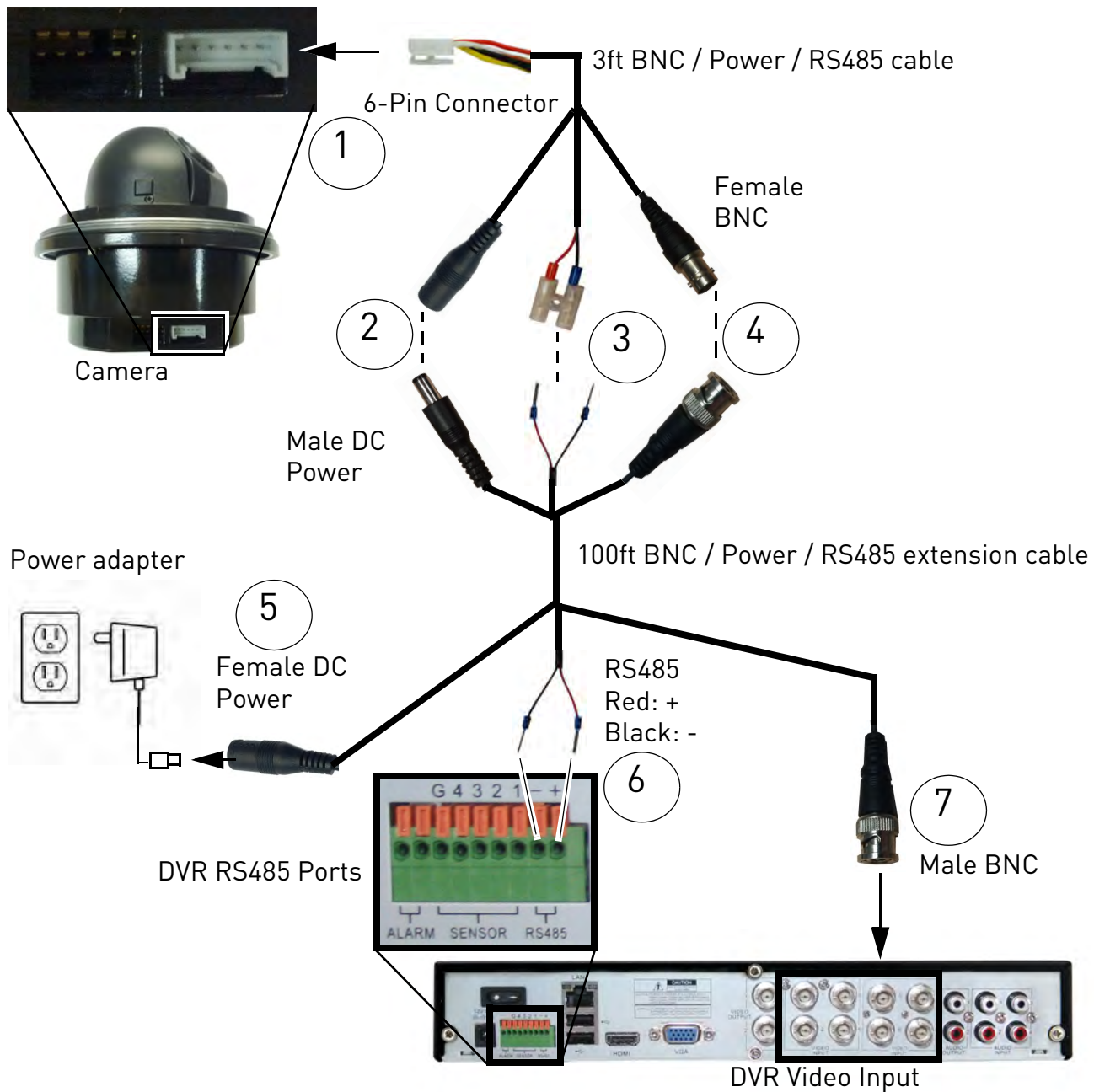

1. Connect the 6-pin connector on the 3ft cable to the camera.
  - To do this, you must remove the camera from the case. Rotate the dome cover counterclockwise to remove. Remove the base attachment screws (3x) and remove the camera base. See illustration below.

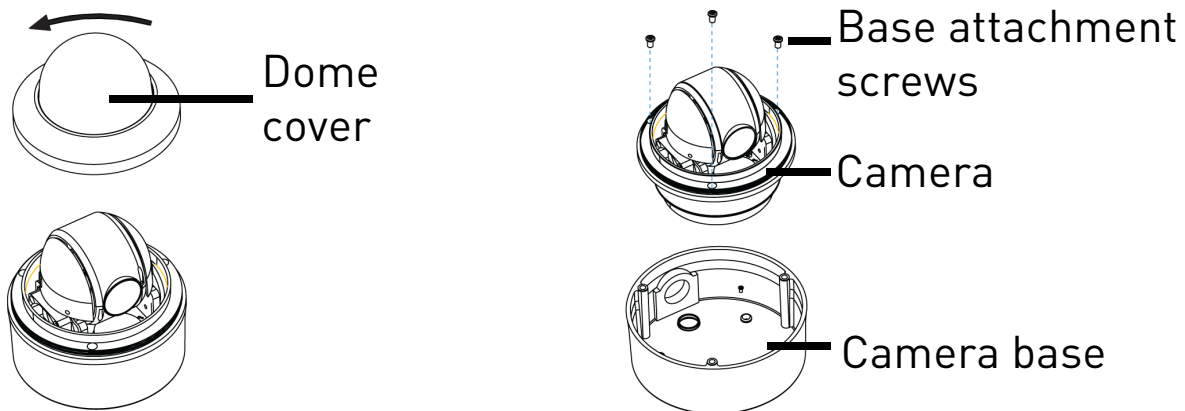

### Removing the camera from the case

**NOTE:** Do not use force when pulling out the 6-pin connector. The 6-pin connector has a release latch under the connector. Press the latch when disconnecting it from the camera.

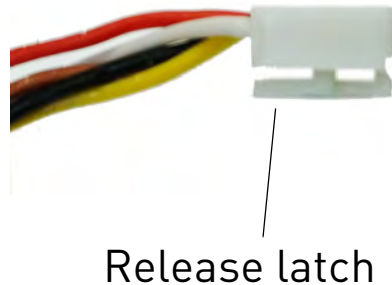

2. Connect the female power connector on the 3ft cable to the male power connector on the 100ft extension cable.
 

**OR**

 Connect the power adapter directly to the camera and to a local power outlet.

3. Use a Philips screwdriver (not included) to loosen the 2 screws on the RS485 connection block furthest from the pre-attached wires. Insert the RS485 wires into the RS485 connection block (red to red, black to black). Tighten the screws on the RS485 connection block to secure the wires in place.

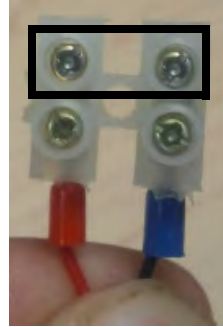

Loosen screws

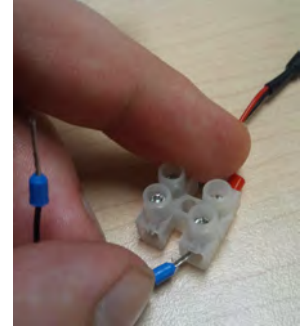

Insert wires

4. Connect the BNC female connector on the 3ft cable to the BNC male connector on the 100ft extension cable.
5. Connect the power connector on the 100ft extension cable to the included power adapter. Plug the power adapter into a power outlet.
6. Connect the RS485 connectors to the RS485 ports on the alarm block on your DVR. The layout of the alarm block may differ depending on your DVR model (common terms include RS485, RS422, or PTZ).

- The RS485 connectors are a pair of bare 24-gauge wires. The red wire is positive (+) and is connected to the + port on the RS485 section of the alarm block, and the black wire is negative (-) and is connected to the - port.

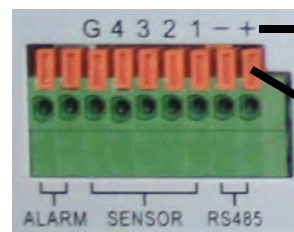

+ / - RS485 Ports

Insert a screwdriver and then insert wires

### Spring loaded lock alarm block

- Most DVR's either use screws or a spring loaded lock to hold the RS485 wires in place. For a spring loaded lock, insert a screwdriver or small object into the lock, insert the wires, and then remove the screwdriver to lock the wires in place.



+ / - RS485 Ports

Tighten screws above ports to secure wires

### Screw lock alarm block

- If the wires can be easily removed, they may become disconnected and affect control of the camera. Use wire strippers (not included) to expose more of the wires if needed.
7. Connect the male BNC connector on the 100ft extension cable to an available **Video IN** port on the DVR.

## 2.1 DEFAULT PROTOCOL INFORMATION

Unlike standard security cameras, PTZ (pan-tilt-zoom) cameras require special protocol information to enable a Security DVR to control the camera movement.

**Input the following information into your DVR to enable PTZ controls.**

- **Default ID:** 1
- **Default Baud Rate:** 2400
- **Default Protocol:** Pelco-D

For details on setting up your DVR with the PTZ camera, see “Controlling the PTZ Camera with your DVR” on page 16.

**You will not need to change the default protocol information on your camera unless you are using multiple PTZ cameras or if your DVR does not support the default settings** (see your DVR’s instruction manual for details). If you need to change the PTZ protocol information, see “Changing Protocol Information” on page 21.



## 3. INSTALLATION

### 3.1 INSTALLATION TIPS AND WARNINGS



**Make sure** to install the camera in a location that can support the camera weight.

**Make sure** there are no live electrical cables in the area where you plan to mount the camera.

- **Camera is rated for outdoor use and is weatherproof using included wall mount only.** For indoor installations, camera may be directly attached to a ceiling.
- Before installing, connect the camera to the DVR and configure the PTZ protocol information as needed to ensure that you can control the camera once installed. It is very difficult to change the protocol information once the camera is installed.
- Camera is capable of seeing in extremely low light conditions (0.02 Lux), but it cannot see in total darkness. It is recommended to install the camera where there is some ambient light (e.g. street lighting or starlight, moonlight, etc.) or leave some lighting on in the area where the camera is installed.
- To extend the length of the cable, see “Extension Cables” on page 8.
- Mount the camera where the lens is away from direct and intense sunlight.
- Plan your cable wiring so that it does not interfere with power lines or telephone lines.
- Ensure that the camera wiring is not exposed or easily cut.
- Mount the camera in an area that is visible but out of reach.

## 3.2 EXTENSION CABLES

- Included extension cable is 100ft / 30m long.
- Because this is a high-powered PTZ camera, **the power cable cannot be extended beyond 100ft.**
  - Alternatively, you may connect the included power adapter directly to the camera's power connector and plug the adapter into a power outlet near the camera. Use the included 100ft extension cable to connect RS485 and BNC cables to your DVR or use the guidelines below to extend the RS485 signal.
- BNC video and PTZ control (RS485) wires can be extended an additional 250ft / 76m up to a maximum length of 350ft / 106m. Video quality may decrease if your extension cables are too long.
- To extend BNC video cable beyond 100ft, purchase RG59 coaxial extension cables. It is recommended to use video cables with the following specification: RG59U 95% Braid 20AWG or better.
- To extend the PTZ control (RS485) wires beyond 100ft, purchase a pair of 24-gauge wires.
- Both RG59 coaxial cable and 24-gauge wires should be available from your local building supply store.

### 3.3 WALL MOUNT INSTALLATION (INDOOR/OUTDOOR)



**Make sure** to disconnect the power adapter before installing the camera. Camera will begin moving immediately when power adapter is connected.

Camera can be installed to a wall using the included wall mount. This method is suitable for indoor or outdoor installations.

#### To install the camera:

1. Make sure the O-rings (3x) are attached to the top of the pendant cap (spares are included). Firmly insert the pendant cap on to the wall mount bracket and twist to tighten all the way. Insert the bracket screws (3x) to secure pendant cap to wall mount bracket.
2. Use the back of the wall mount to drill holes for the mounting screws. If you are running cables through the wall, also drill a hole for the cables. Run the single end of the cable through the wall mount and attach the wall mount to the wall using the wall mounting screws (4x) supplied with the wall mount.

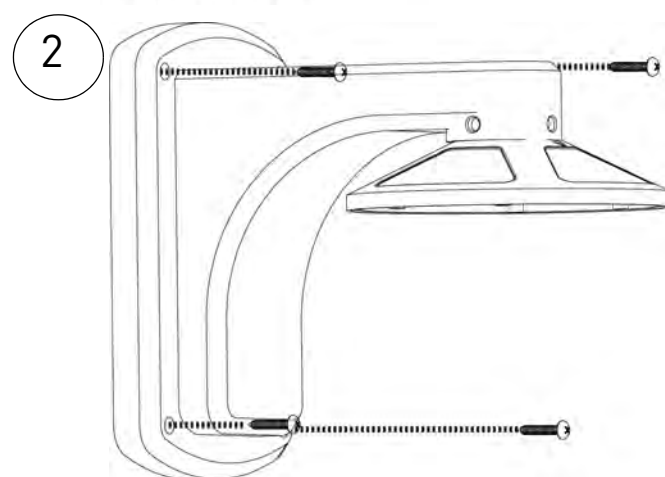
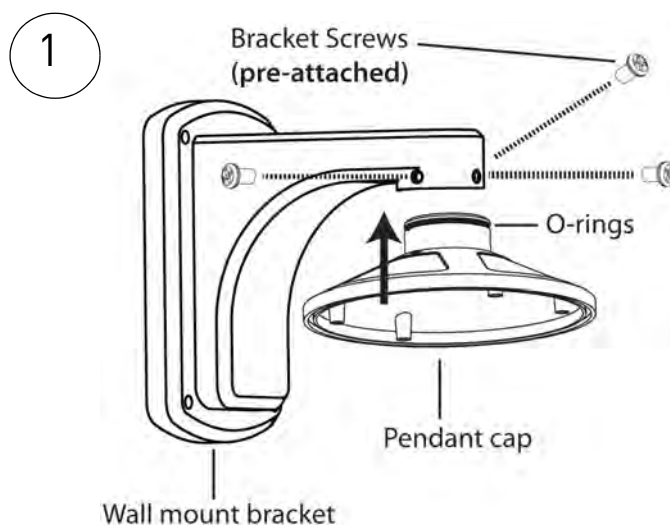

**NOTE:** Use the included drywall anchors if installing in drywall.

3. Rotate the camera dome cover counterclockwise to remove.

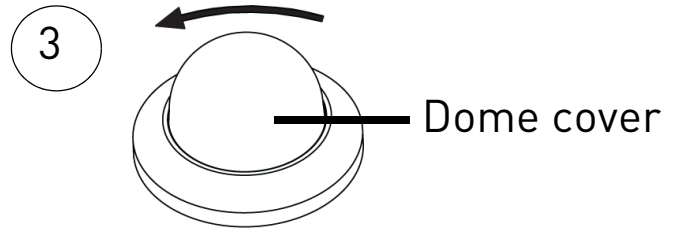

4. Remove the base attachment screws (3x) and remove the camera from the camera base.

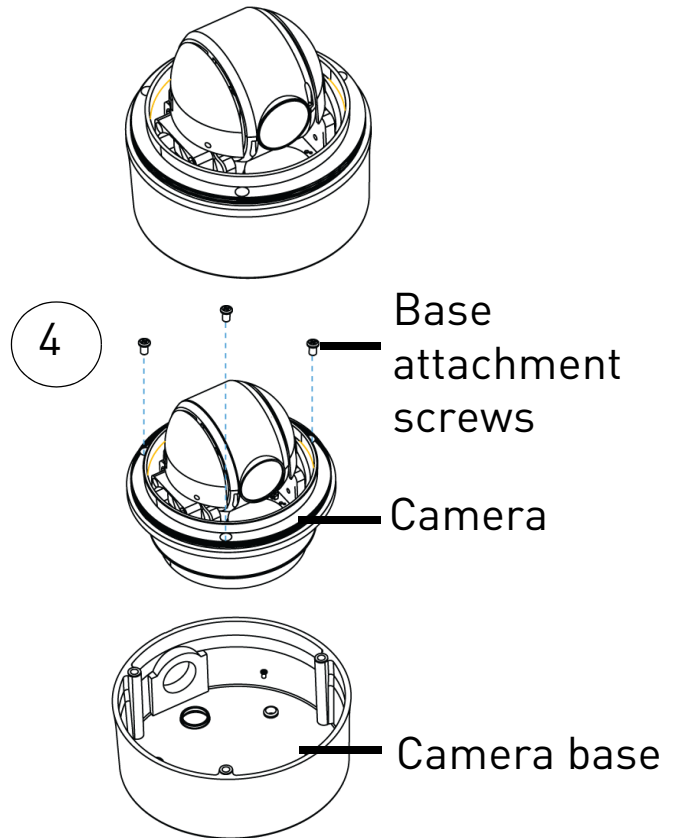

5. Remove the rubber plug on the bottom of the camera base and run the single end of the cable through the bottom of the camera base. Attach the camera base to the pendant cap using the camera attachment screws (4x).

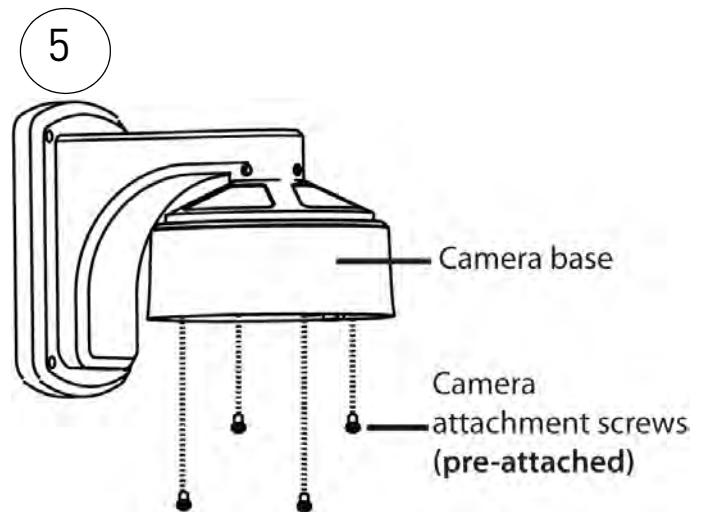

6. Connect the cable to the camera (see “Connecting the Camera” on page 2). Attach the camera to the base using the base attachment screws (3x) then reattach the dome cover by rotating it clockwise.

**NOTE:** Make sure power adapter is disconnected before connecting the 6-pin connector. Camera will begin moving immediately when power adapter is connected.

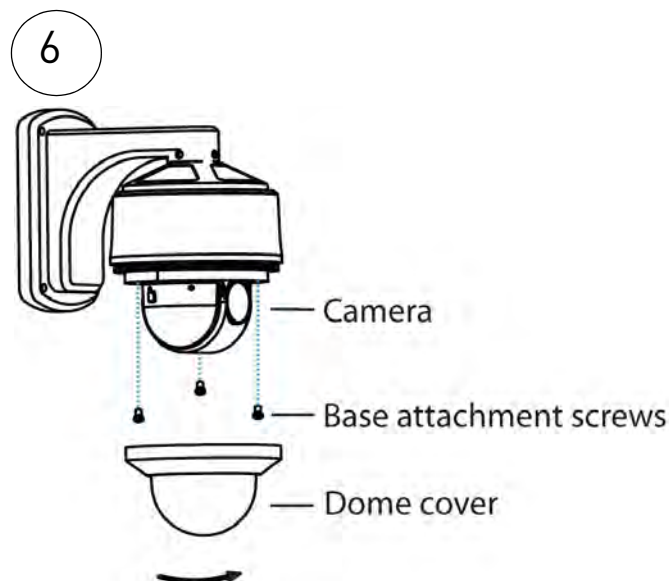

7. Remove the protective vinyl sheet from the dome cover.

- For details on DVR setup, see “Controlling the PTZ Camera with your DVR” on page 16.

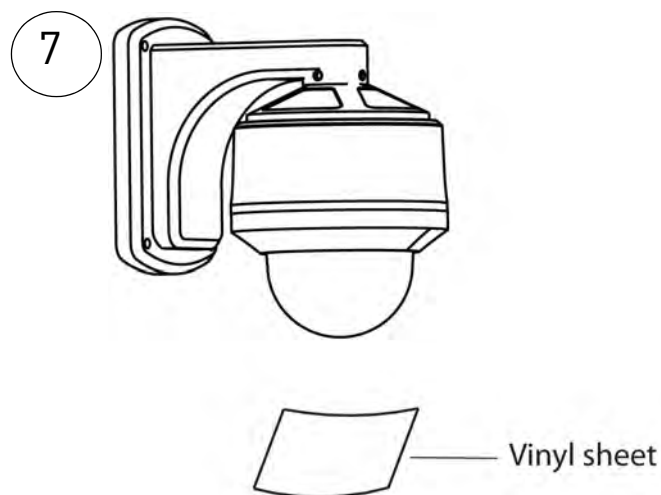

### 3.4 CEILING INSTALL (INDOOR ONLY)



**Make sure** to disconnect the power adapter before installing the camera. Camera will begin moving immediately when power adapter is connected.



**Camera is not weatherproof if installed using this method.** Use the included wall mount for outdoor installations.

Camera can be installed directly to a ceiling.

#### To install the camera:

1. Remove the cutouts for the cable and mounting screw holes and place the foam pad onto the bottom of the camera base with the cutouts aligned with the holes on the bottom of the camera.



Cable and mounting screw cutouts

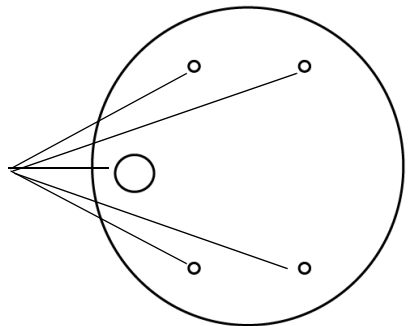

Foam Pad

2. Rotate the dome cover counterclockwise to remove.

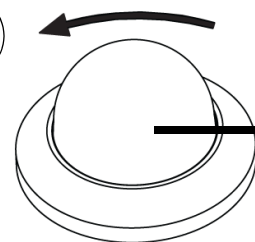

Dome cover

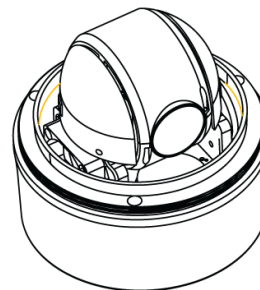

3. Remove the base attachment screws (3x) and remove the camera from the camera base.

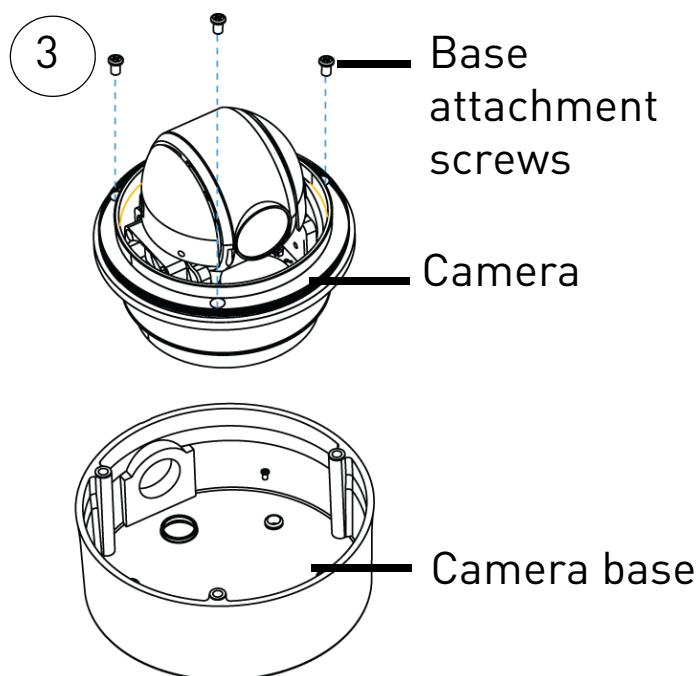

4. Remove the rubber plug on the bottom of the camera base and run the 6-pin connector through the cable hole.
5. Drill holes for the mounting screws (x4) and the cable and run the cable through the hole.

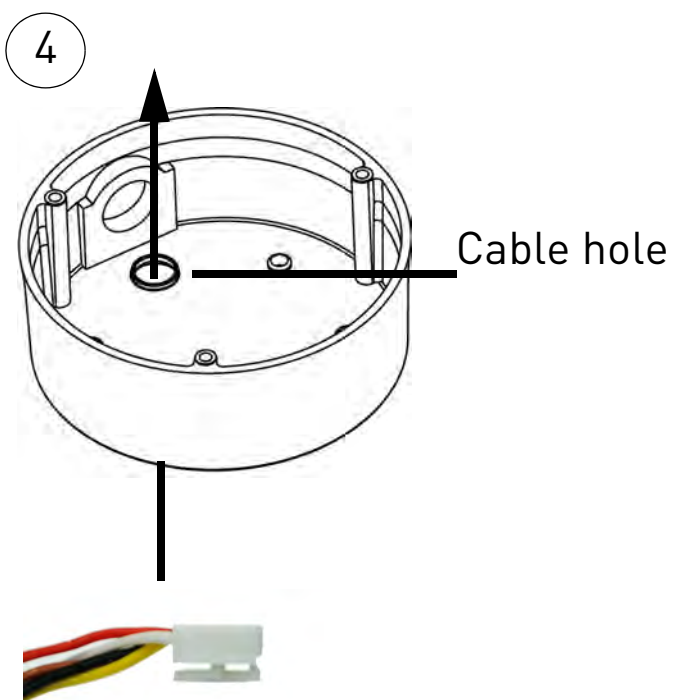

6-Pin Connector

6. Attach the camera base to the ceiling using the included mounting screws (x4).

**NOTE:** Use the included drywall anchors if installing the camera in drywall.

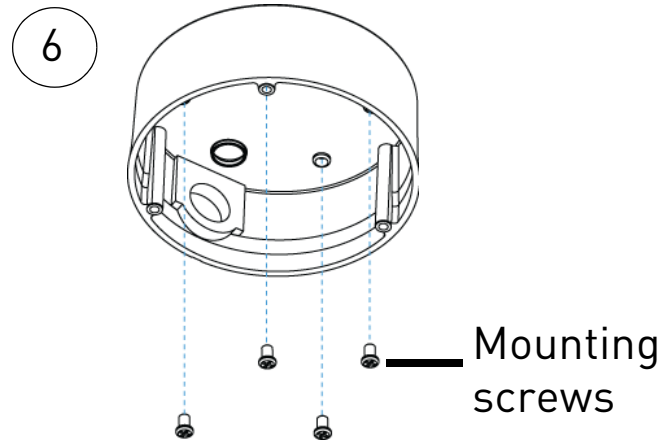

7. Connect the 6-pin connector to the camera.

**NOTE:** Make sure power adapter is disconnected before connecting the 6-pin connector. Camera will begin moving immediately when power adapter is connected.

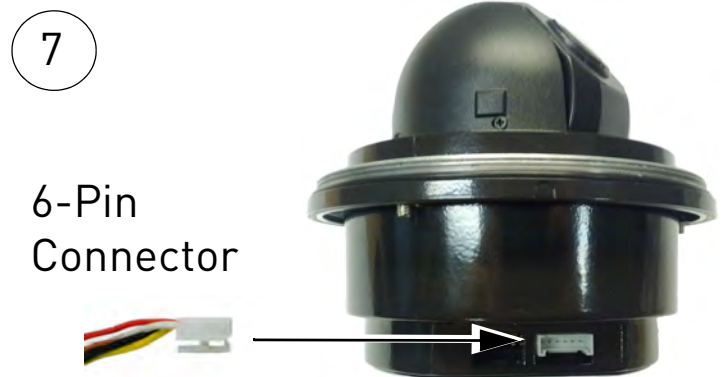

8. Attach the camera to the base using the base attachment screws (3x).

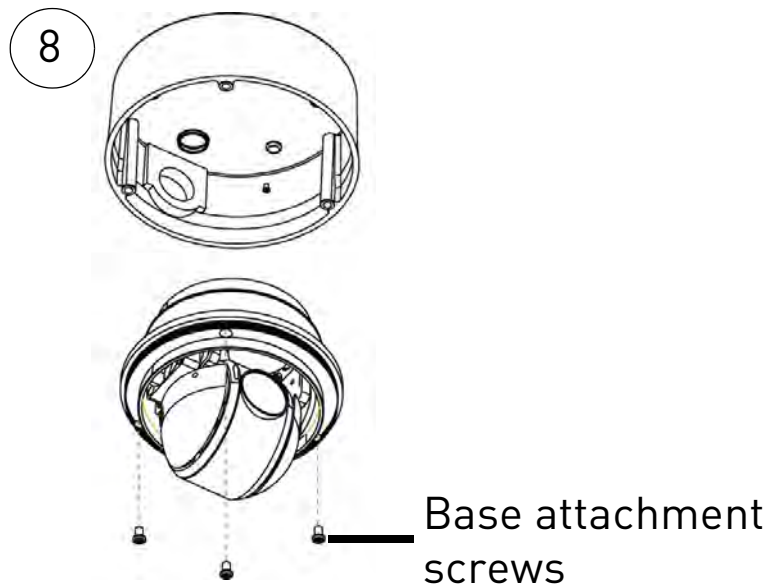



9. Reattach the dome cover by rotating it clockwise.  
Remove protective vinyl from dome cover.

10. Connect the cables. For details, see "Connecting the Camera" on page 2.

- For details on DVR setup, see "Controlling the PTZ Camera with your DVR" on page 16.

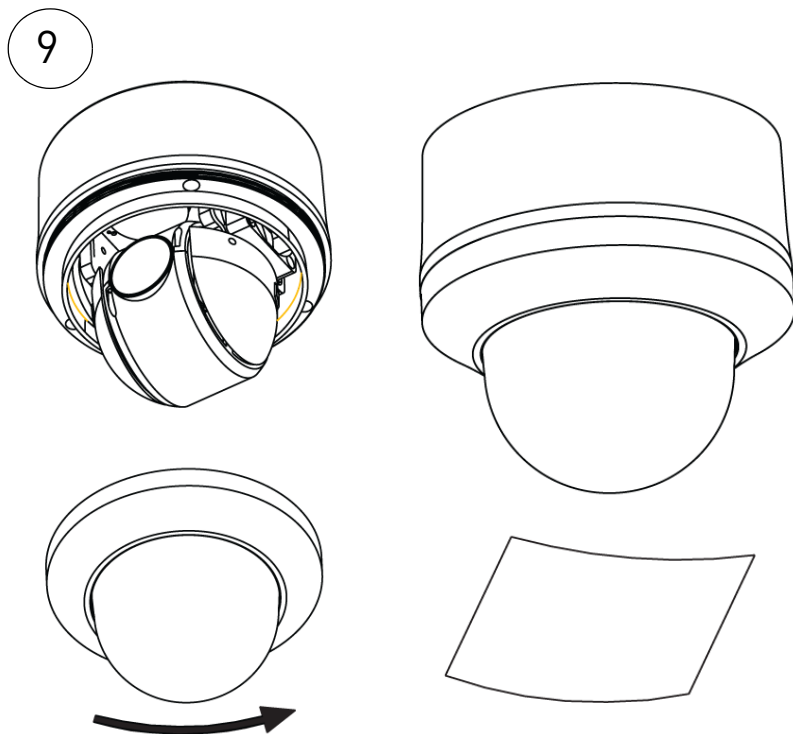

## 4. CONTROLLING THE PTZ CAMERA WITH YOUR DVR

Once your camera is connected to the DVR, you must perform initial setup to control the camera using the DVR. Once this setup is complete, you will be able to move the camera, configure preset positions, and use other advanced controls.

PTZ features that are available to you will depend on the model of DVR that you have. The following instructions are based on the Lorex ECO2 DVR's (LH130 Series). For other DVR models, check your instruction manual for details.

### 4.1 INITIAL SETUP

In the initial setup process, you will input the camera's protocol information into your DVR. This enables PTZ functionality.

**TIP:** The camera will display the configured PTZ protocol information when it starts up. To quickly display this information, disconnect and reconnect the power adapter.

#### **To perform initial setup using a Lorex ECO2 DVR:**

1. Ensure the cables are connected correctly to the DVR according to "Connecting the Camera" on page 2.
2. On the DVR, Right-click with the mouse to open the Menu Bar and click the Main Menu button (.
3. Click **Device** and select the **PTZ** tab.

## 4. Configure the following:

- **Channel:** Select the channel the camera is connected to.
- **Protocol:** Select the protocol (default: **Pelco-D**).
- **Baud rate:** Select the camera's baud rate (default: **2400**).
- **Data Bit:** Select **8**.
- **Stop Bit:** Select **1**.
- **Parity:** Select **None**.
- **Cruise:** Select **Enable** to enable PTZ cruise.
- **Address:** Enter the camera's ID (default: **001**).

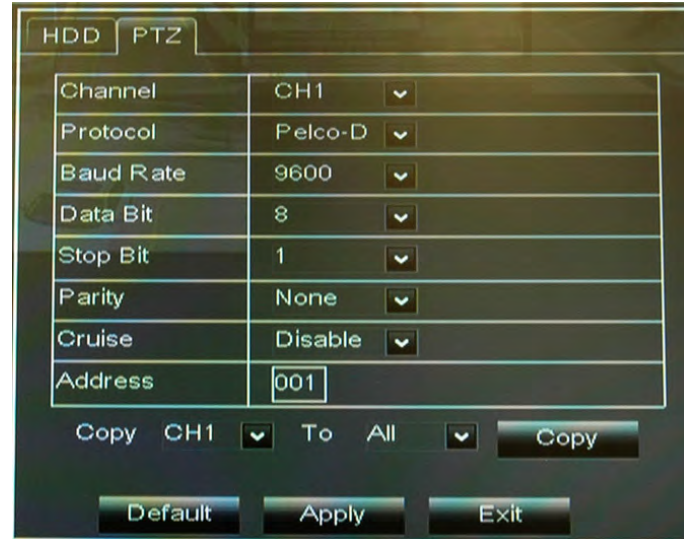
5. Click **Apply** to save your settings.

## 4.2 CONTROLLING THE CAMERA

**TIP:** Turn off motion detection on your DVR for the channel with the PTZ camera connected. Otherwise, the DVR will detect the PTZ movement as motion. See your DVR's instruction manual for details.

### To control the PTZ camera locally on the EC02 DVR:

1. Select the channel that the PTZ camera is connected to.
2. Press and hold the **PTZ** button on the front panel of the system for 6 seconds.

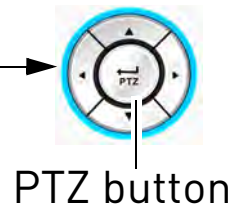

**Press & hold  
6 seconds**

- **OR,** Right-click with the mouse to open the Menu Bar and click the PTZ button (☐).
- Enter the DVR password (default: **000000**) and click **Apply**.

3. Use the on-screen PTZ controls to control the camera.

**Channel:**

Select the channel with the PTZ camera

**Speed Slider:**

Increase or decrease the pan and tilt speed

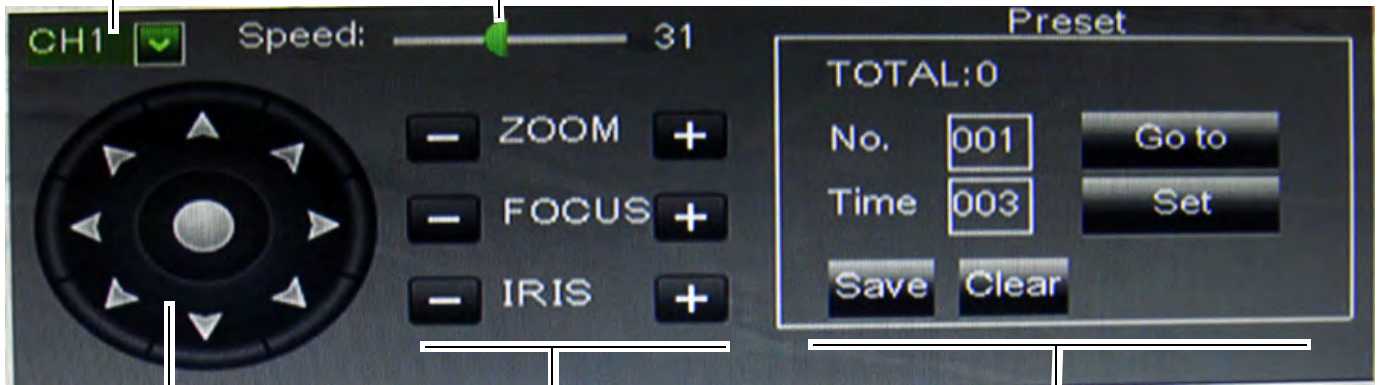

**Direction keys:**

Click to pan and tilt the camera

Click + / - to adjust the camera Zoom, Focus, and Iris settings

**Camera Pre-set controls (see page 19)**

**ATTENTION:** This PTZ camera is designed tilt up and down within a range of 155°. Tilting less than 10° or greater than 165° away from the camera base may cause the image to become slightly unclear.

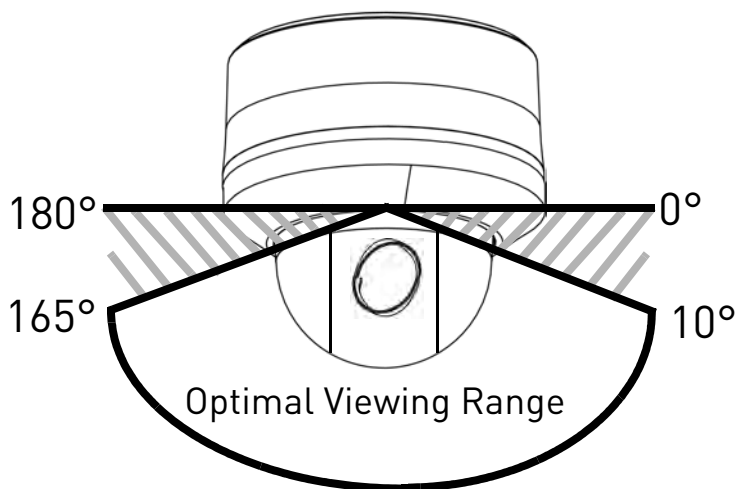

If this happens, use the DVR controls to tilt the camera between 10° and 165°. The camera's tilt angle appears on the monitor when it moves.

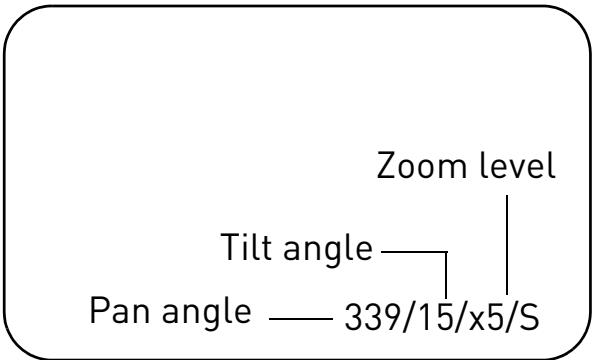

## 4.3 PTZ PRESETS AND PTZ CRUISE

Using the DVR, you can create presets. Presets allow you to save different positions of the camera, so you can return the camera to these positions without using the manual controls.

A PTZ cruise (referred to on some DVR's as a tour or scan), allows you to configure a sequence of presets that the camera will automatically cycle through. This is useful if you want the camera to monitor a large area, without manually having to control the camera.

**NOTE:** These features may not be available on all DVR's. Check your DVR instruction manual for details.

## 4.4 SETTING PTZ PRESETS ON THE ECO2 DVR

1. Using the direction keys, zoom, focus, and iris settings, move the camera into position.
2. (Optional) In the **Time** field, select the number of seconds the camera will remain in that position during PTZ cruise before going to the next position.
3. Click **Set** to set the preset. The Total and No. field will automatically increase. The Total field shows you the total number of created presets, and the No. field shows you the number of the preset you are currently creating.

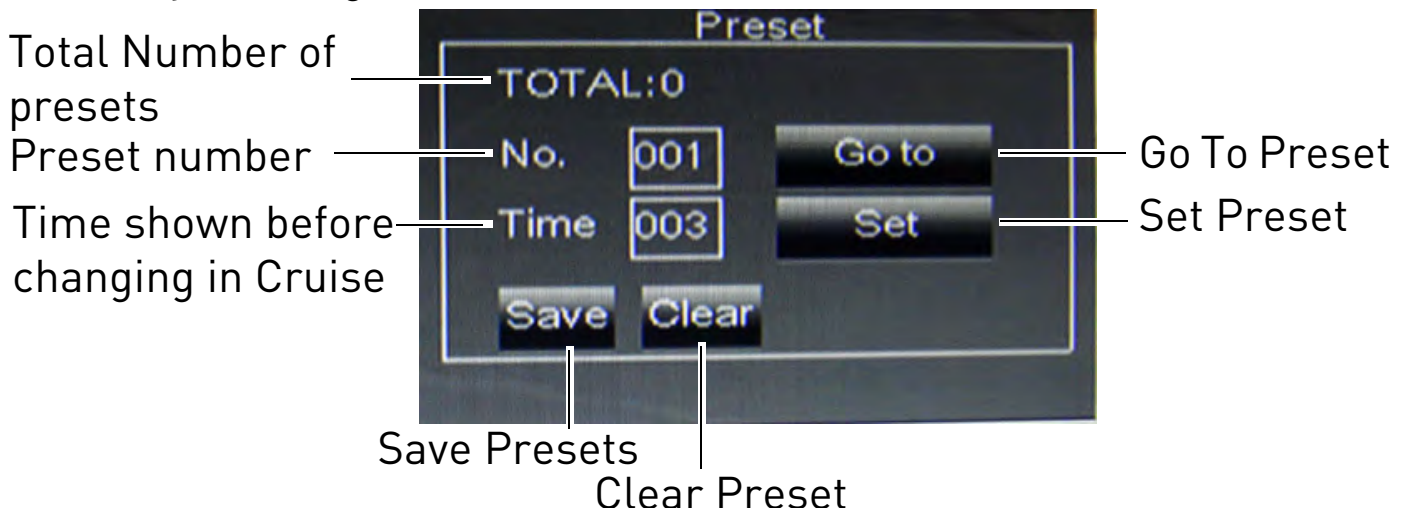

4. Complete the steps above to create additional presets as needed. Press **Save** when you are finished to save all created presets.

## 4.5 SELECTING PTZ PRESETS ON THE ECO2 DVR

1. In the **No.** field, select the number of the preset you would like to select.
2. Click **Go to** to go to the preset.



## 4.6 DELETING PTZ PRESETS ON THE ECO2 DVR

1. In the **No.** field, select the number of the preset you would like to delete.
2. Click **Clear** to delete the preset and click **Save** to save your changes.

## 4.7 STARTING / STOPPING PTZ CRUISE ON THE ECO2 DVR

When PTZ cruise is enabled, the camera will cycle through saved presets. You must set and save presets to use PTZ cruise. For details on setting presets, see “Setting PTZ Presets on the ECO2 DVR” on page 19.

### To start / stop PTZ cruise on the ECO2 DVR:

1. Right-click to exit PTZ menu.
2. Right-click to open the Menu Bar and click the Start Cruise button (). Enter the DVR password (default: **000000**). The camera will cycle through PTZ presets.
3. To stop the PTZ cruise, right-click to open the Menu Bar and click the Stop Cruise button (). Enter the DVR password (default: **000000**).

## 5. CHANGING PROTOCOL INFORMATION

The camera's PTZ protocol information allows a DVR to communicate with it and control the camera's movement. **You will not need to change the default protocol information on your camera unless you are using multiple PTZ cameras or if your DVR does not support the default settings** (see your DVR's instruction manual for details).

PTZ protocol information on this camera is set using DIP switches on the bottom of the camera. DIP switches represent binary values. This means that they are either On (1) or Off (0).

The DIP switches control 3 values:

1. The **ID** of the camera, which allows the DVR to identify different PTZ cameras.
2. The **protocol**, which is the language that allows the camera and DVR to speak to each other (e.g. Pelco D).
3. The **baud rate**, which is the frequency of communications.

The illustration below shows the default values of the DIP switches.

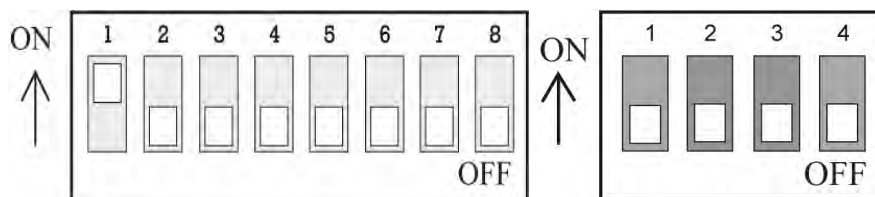

**Default ID: 1**

**Default Baud Rate: 2400**

**Default Protocol: Pelco-D**

## 5.1 ACCESSING THE DIP SWITCHES

To access the DIP switches, you must remove the camera from the case. To do this, you must remove the camera from the case. Rotate the dome cover counterclockwise to remove. Remove the base attachment screws (3x) and remove the camera base. See illustration below.

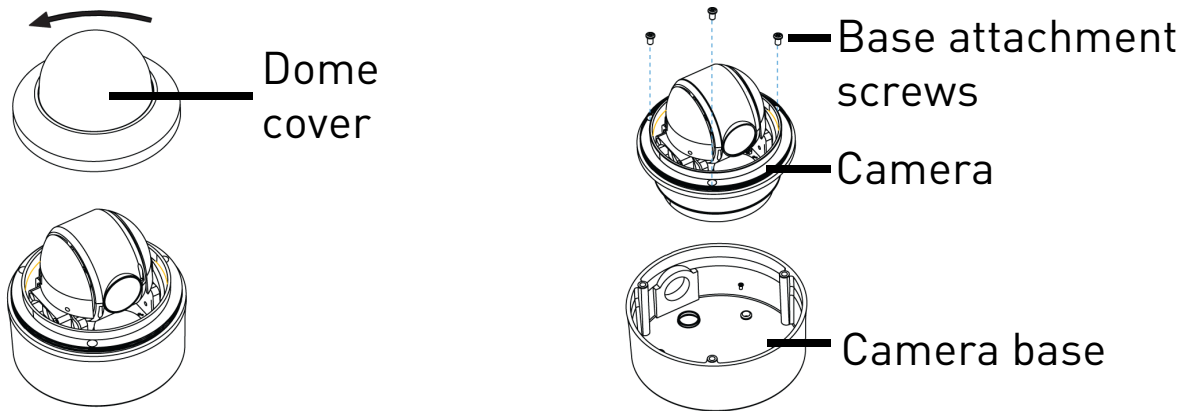

**Removing the camera from the case**

## 5.2 SETTING THE CAMERA ID

The camera ID is how the DVR identifies PTZ cameras.

Camera ID is set using the larger DIP switch panel with 8 switches. Each switch represents a binary digit (i.e. switch #1=1, #2=2, #3=4, etc.). Camera ID can be anything between 1-255. See the address example table on the next page.

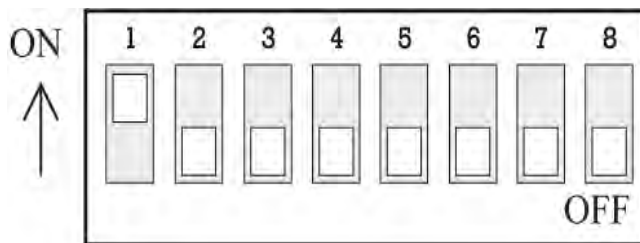

**Camera ID DIP Switches**



**IMPORTANT**

You cannot use the same ID for more than 1 PTZ camera.

You cannot set an ID with a value of 0.

ID	Switch is ON or OFF							
	1	2	3	4	5	6	7	8
<b>1</b>	ON	OFF	OFF	OFF	OFF	OFF	OFF	OFF
<b>2</b>	OFF	ON	OFF	OFF	OFF	OFF	OFF	OFF
<b>3</b>	ON	ON	OFF	OFF	OFF	OFF	OFF	OFF
<b>4</b>	OFF	OFF	ON	OFF	OFF	OFF	OFF	OFF
<b>5</b>	ON	OFF	ON	OFF	OFF	OFF	OFF	OFF
<b>6</b>	OFF	ON	ON	OFF	OFF	OFF	OFF	OFF
<b>7</b>	ON	ON	ON	OFF	OFF	OFF	OFF	OFF
<b>8</b>	OFF	OFF	OFF	ON	OFF	OFF	OFF	OFF
<b>9</b>	ON	OFF	OFF	ON	OFF	OFF	OFF	OFF
<b>10</b>	OFF	ON	OFF	ON	OFF	OFF	OFF	OFF
<b>11</b>	ON	ON	OFF	ON	OFF	OFF	OFF	OFF
<b>12</b>	OFF	OFF	ON	ON	OFF	OFF	OFF	OFF
<b>13</b>	ON	OFF	ON	ON	OFF	OFF	OFF	OFF
<b>14</b>	OFF	ON	ON	ON	OFF	OFF	OFF	OFF
<b>15</b>	ON	ON	ON	ON	OFF	OFF	OFF	OFF
<b>16</b>	OFF	OFF	OFF	OFF	ON	OFF	OFF	OFF

## 5.3 SETTING THE CAMERA PROTOCOL AND BAUD RATE

The protocol is the language that allows the camera and DVR to communicate, and the baud rate is the frequency of signal sent to the camera. The camera supports Pelco-D and Pelco-P protocols.

Protocol and baud rate are set using switches 1&2 on the smaller DIP switch panel. See the table below.

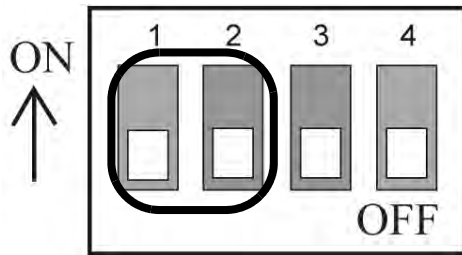

**Protocol and Baud Rate Switches**

<b>1</b>	<b>2</b>	<b>Protocol/Baud Rate</b>
OFF	OFF	Pelco-D 2400
ON	OFF	Pelco-D 9600
OFF	ON	Pelco-P 4800
ON	ON	Pelco-P 9600

**IMPORTANT**

Switches 3& 4 are for manufacturer use only and should always be set to OFF.

## 6. TECHNICAL SPECIFICATIONS

Image Sensor	1/3" Sony Ex-View HAD CCD II
Video Format	NTSC
Effective Pixels	976(H) x 494 (V)
Resolution	up to 700 TVL
Range	360° Pan (Endless) 155° Tilt (Auto-Flip)
Pan/Tilt Speed	Max 360°/Sec.
Zoom	10x Optical Zoom & 10x Digital Zoom
Protocol	Pelco-D, Pelco-P
Min. Illumination	0.7 Lux in Color 0.02 Lux in Black and White
Lens / Lens Type	Auto Focus / 3.8-38mm F 1.8
S / N Ratio	50db (AGC Off)
Iris	Auto Iris
Termination	BNC Video / RS485 / DC Power
Video Output	Composite 1.0Vpp @ 75ohm
Power Requirement	12V DC ±10%
Power Consumption	Max. 850mA
Operating Temperature Range	-4°F ~ 122°F / -20°C ~ 50°C
Operating Humidity Range	within 90%RH
Indoor/Outdoor	Both(IP66 <sup>1</sup> )
Weight (camera)	2.15lbs / 0.96kg
Weight (Camera & Wall Mount)	3.0lbs / 1.4kg

1. Wall mount required for outdoor installation. Not intended for submersion in water. Installation in a sheltered location recommended.

# 7. DIMENSIONS

Units: mm

Camera

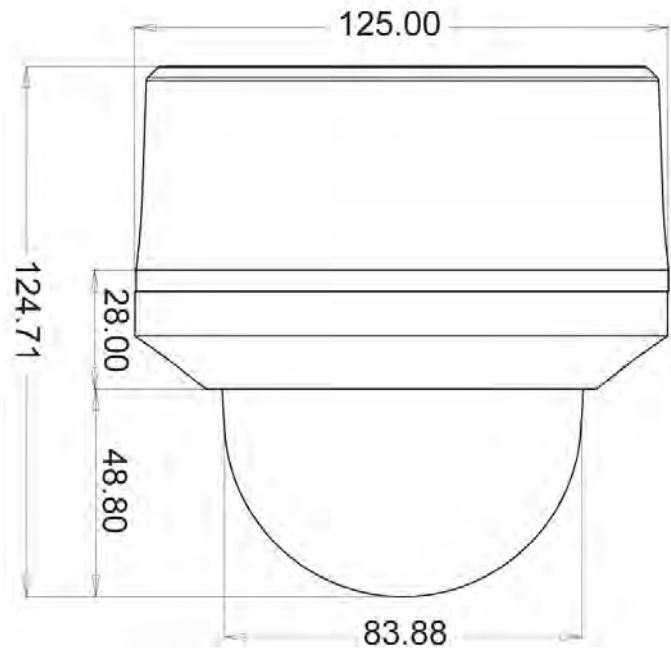

Camera and Wall Mount

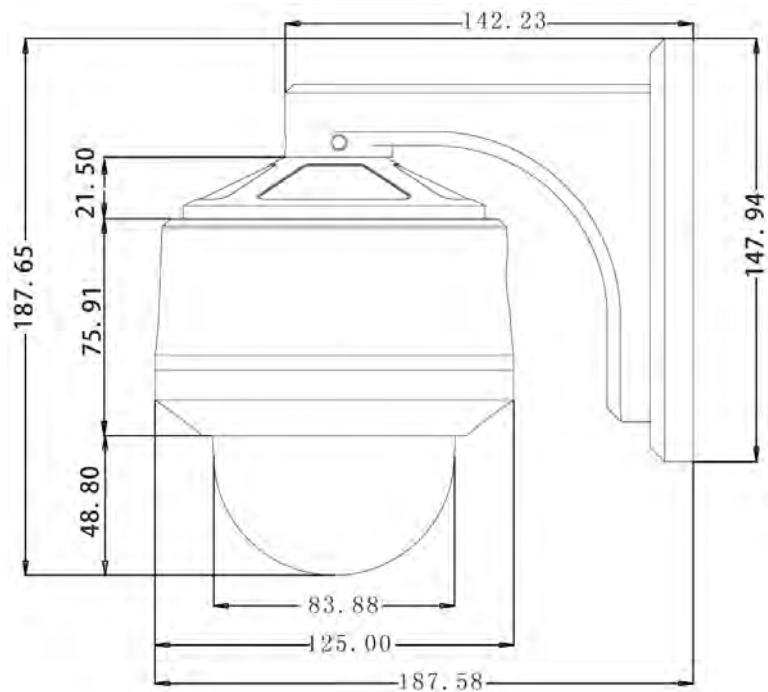

## 8. TROUBLESHOOTING

### There is no picture at night

- Camera is capable of seeing in extremely low light conditions (0.02 Lux), but it cannot see in total darkness. It is recommended to install the camera where there is some ambient light (e.g. street lighting or starlight, moonlight, etc.) or leave a light on in the area where the camera is installed.

### No image at startup

- Check to ensure your camera is properly connected (see “Connecting the Camera” on page 2) and the power adapter is plugged in.
- Connect the power adapter to a different outlet.
- Make sure power adapter is the original one provided. Do not use other power adapters with this product, as this will void the warranty.

### No image or camera image is unclear

- Dome cover is dirty. Clean the dome cover with a soft, slightly damp cloth. Do not use anything other than water to clean the dome cover, as chemicals such as acetone can permanently damage the plastic.
- Extension cable run may be too long (see “Extension Cables” on page 8 for details).
- Voltage may drop over distance and affect image quality. The power adapter must be connected at either the end of the provided 100ft cable or directly to the 3ft cable.

### Image is distorted

- Image may become unclear when camera is tilted too close to the camera base (e.g. pointed parallel to the ceiling). Tilt the camera using DVR PTZ controls.

## **PTZ controls are not working or are not working properly**

- RS485 wires not connected or connected using wrong polarity. Ensure the red wire is connected to the + RS485 port and the black wire is connected to the - RS485 port.
- Not enough of RS485 wire is exposed to make proper connection. Use a wire stripper (not included) to strip off some of the wire insulation.
- Extension cables may be damaged or are not connected properly. Check your extension cable run.
- PTZ protocol details are not configured in DVR. See your DVR instruction manual for details.
- Multiple PTZ cameras are using the same camera ID. This will either disable or affect PTZ controls. Configure a separate camera ID for each camera (see “Setting the Camera ID” on page 22 for details).

## **DVR motion detection is constantly triggering**

- Turn off motion detection on the channel the PTZ camera is connected to. DVR's use video motion detection, which means they detect motion by looking for changes between frames (images) in the video. If the camera is moving, the DVR will detect this as motion.



# EXPAND AND CUSTOMIZE YOUR SYSTEM WITH A FULL RANGE OF CAMERAS & ACCESSORIES



**Specialty Cameras**



**Wireless Cameras**



**Dome Cameras**



**Digital Video Recorders**



**Monitors**



**Simulated Cameras**



**Security Hard Disc Drives**



**Extension Cables**



**Accessories**

[www.lorextechnology.com](http://www.lorextechnology.com)

1-888-42-LOREX (1-888-425-6739)