

Wireless Ceiling Mount Sensor

Lutron’s ceiling-mounted occupancy/vacancy sensors are wireless, battery-powered passive infrared (PIR) sensors that automatically control lights via RF communication to compatible dimming and switching devices. These sensors detect the heat from people moving within an area to determine when the space is occupied. The sensors then wirelessly transmit the appropriate commands to the associated dimming and switching devices to turn the lights on or off automatically. They combine both convenience and exceptional energy savings along with ease of installation.

Features

- Wireless occupancy sensor has 3 settings available: Auto-On/Auto-Off, Auto-On Low-Light/Auto-Off, and Manual-On/Auto-Off
- Auto-On Low-Light feature will only turn lights on automatically if there is less than approximately 1 fc (10 lux) of ambient light
- Vacancy model available to meet CA Title 24 requirements
- 10-year battery life design
- Passive infrared motion detection with exclusive Lutron XCT™ Technology for fine motion detection
- 360° coverage ranges from 324 sq ft (98 m²) to 676 sq ft (206 m²) (depending on mounting height)
- Multiple ceiling-mount methods available for different ceiling materials
- RoHS compliant
- Simple and intuitive adjustments available for Timeout, Auto-On, and Activity settings
- Front accessible test buttons make setup easy
- Lens illuminates during test mode to verify ideal locations
- Multiple sensors can be added for extended coverage—refer to product specification submittal of receiving device to determine system limits

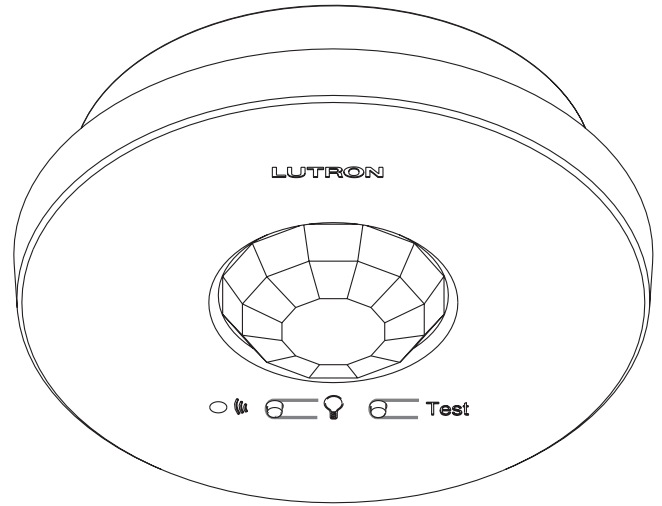

Models Available:

- LRF2-OCR2B-P-WH*
434 MHz Occupancy/Vacancy Sensor
 - LRF2-VCR2B-P-WH*
434 MHz Vacancy Sensor
- *WH (white)

Compatible RF Devices:

- For use with Lutron® products only
- Communicates to the following wireless *Lutron* systems:
 - Maestro® Wireless® (MRF2)
 - GRAFIK Eye® QS Wireless
 - Energi Savr Node™ QS (with QS Sensor Module on QS Link)
 - Quantum® (with QS Sensor Module on QS Link)
 - RadioRA® 2
 - HomeWorks® QS

<p>Job Name:</p> <p>Job Number:</p>	<p>Model Numbers:</p>
--	------------------------------

Specifications

Standards

- FCC certified
- IC certified
- COFETEL certified
- RoHS compliant

Environment

- Temperature: 32 °F to 104 °F (0 °C to 40 °C)
- For indoor use only

Power

- Operating voltage: 3 V_{DC}
- Operating current: 14 µA nominal
- Requires one CR 123 lithium battery
- 10-year battery life design
- Non-volatile memory (saved changes are stored during power loss)

Sensor Coverage Test

- Front accessible test button
- Lens illuminates orange in response to motion during test mode and is visible from 60 ft (18 m)

Wireless Communication Test

- Front accessible test button
- Turn loads on and off

Dimensions

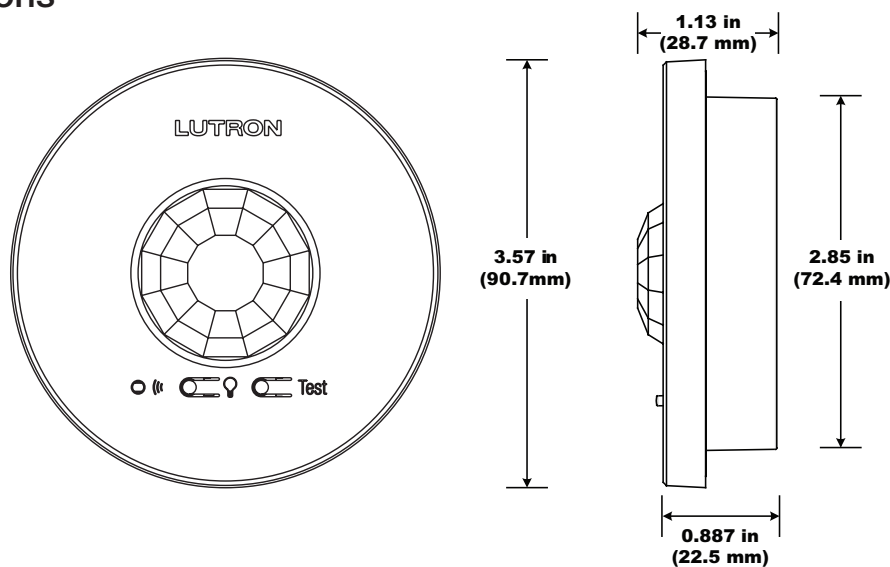

Timeout Options

- 1 minute *
- 5 minutes
- 15 minutes **
- 30 minutes

Auto-On Options (Occupancy Version Only)

- “Always” ** - Sensor turns lights ON and OFF automatically.
- “Low light” - Sensor turns lights ON automatically only in low ambient light conditions. Sensor turns lights OFF automatically.
- “Disable” - Lights must be turned ON manually from dimming or switching device. Sensor turns lights OFF automatically.

Activity Options

- Low Activity ** (Ⓕ)
- Medium Activity (Ⓖ)
- High Activity (Ⓗ)

** - intended for use in high-activity, briefly occupied areas only

* - default settings

Job Name:	Model Numbers:
Job Number:	

Range Diagrams

Sensor Coverage with an 8 ft (2.4 m) Ceiling

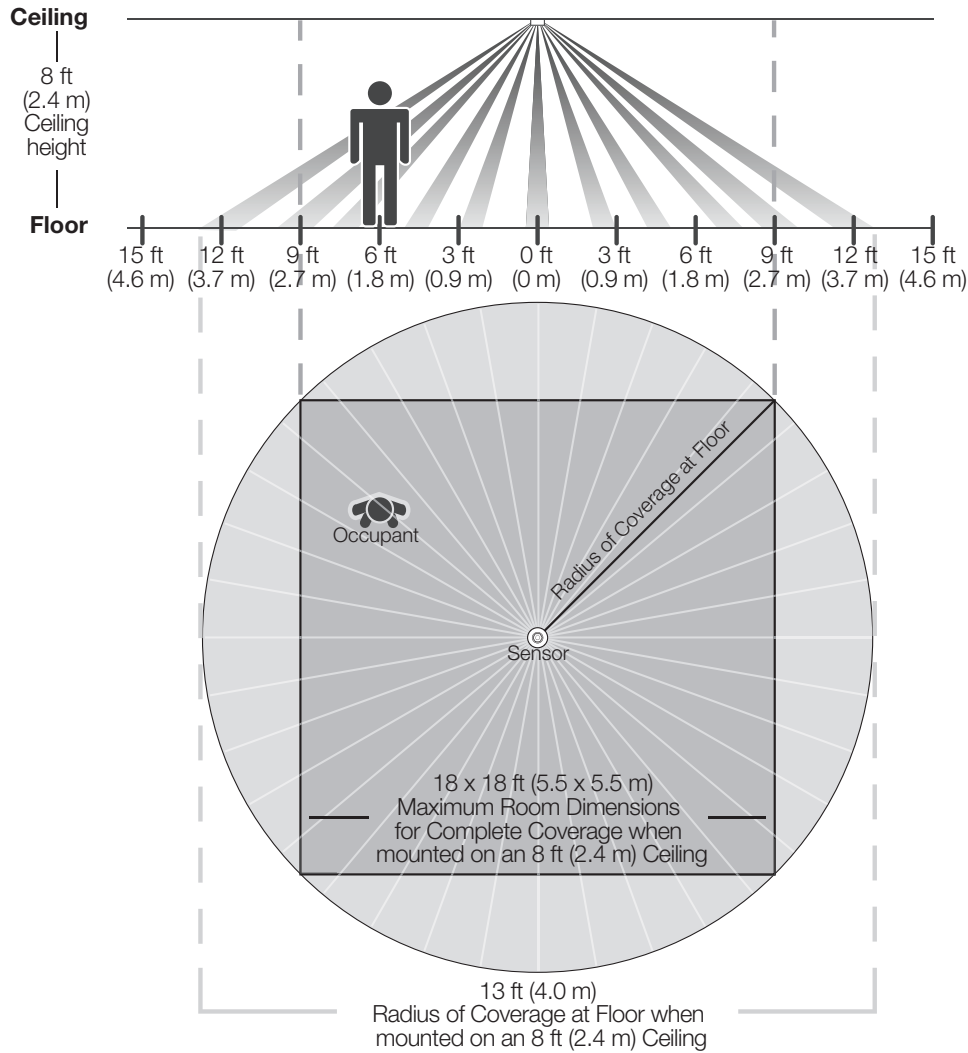

Sensor Coverage Chart (for sensor mounted in center of room)

Ceiling height	Maximum room dimensions for complete floor coverage	Square feet
8 ft (2.4 m)	18 × 18 ft (5.5 × 5.5 m)	324 ft ² (30.2 m ²)
9 ft (2.7 m)	20 × 20 ft (6.1 × 6.1 m)	400 ft ² (37.2 m ²)
10 ft (3.0 m)	22 × 22 ft (6.7 × 6.7 m)	484 ft ² (44.9 m ²)
12 ft (3.7 m)	26 × 26 ft (7.9 × 7.9 m)	676 ft ² (62.4 m ²)

* Multiple sensors can be added for extended coverage—refer to product specification submittal of receiving device to determine system limits.

Job Name:	Model Numbers:
Job Number:	

Installation Overview

Sensor Placement

- The sensor's ability to detect motion requires line of sight of room occupants. The sensor must have an unobstructed view of the room. **DO NOT** mount behind or near tall cabinets, shelves, hanging fixtures, ceiling fans, etc. The sensor cannot see through glass objects such as patio or shower doors.
- Hot objects and moving air currents can affect the sensor's performance. To ensure proper operation, the sensor should be mounted at least 4 ft (1.2 m) away from light bulbs below the ceiling line and HVAC vents.
- The sensor's performance depends on a temperature differential between the ambient room temperature and that of room occupants. Warmer rooms may reduce the sensor's ability to detect occupants.
- The sensor should be mounted within 60 ft (18 m) line of sight or 30 ft (9.1 m) through walls, of the associated dimming and switching receiving devices.

Mounting

- Mounting of any RF devices on or in close proximity to a metal surface (e.g. directly on fixture with metal housing, metal-backed ceiling tile) will drastically reduce the effective range of radio signal transmission or reception.
- All RF devices must be mounted on non-conductive materials to ensure proper performance.

Temporary mounting is recommended to test sensor coverage and wireless communication before permanently installing the sensor.

Drop Ceiling (Compressed Fiber Ceiling Tile)

- The ceiling tile mounting wire is provided for both temporary and permanent mounting of the sensor to ceiling tiles. It is designed to allow temporary mounting, testing, and repositioning (if necessary) of the sensor without damaging a ceiling tile. Once the sensor's final position has been chosen, the mounting wire should be twisted to lock the sensor in place permanently.

Solid Ceiling (Drywall, Plaster, Concrete, or Wood)

- Temporary mounting: One double-sided adhesive strip is provided for temporarily mounting and testing the sensor.
- Permanent mounting: Screws and anchors (for drywall or plaster) provided to mount sensor.

Recess Mount

- Ceiling mount clamps internally to ceiling tile. Sensor twist-locks into mount, sits flush with ceiling (as shown below)
- Opening is 3" in diameter
- Purchased as a separate kit: LRF-CRMK-WH

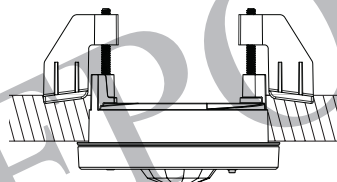
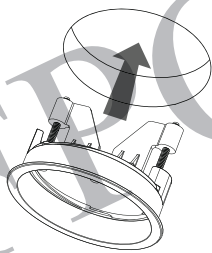

Job Name: Job Number:	Model Numbers:
------------------------------	----------------

Lens Masking

Whenever possible, the sensor should be installed in a location where it cannot easily see into areas outside the intended space, such as hallways or adjacent rooms. If this situation cannot be avoided, portions of the lens are masked with the provided labels to block the sensor's view of the undesired areas.

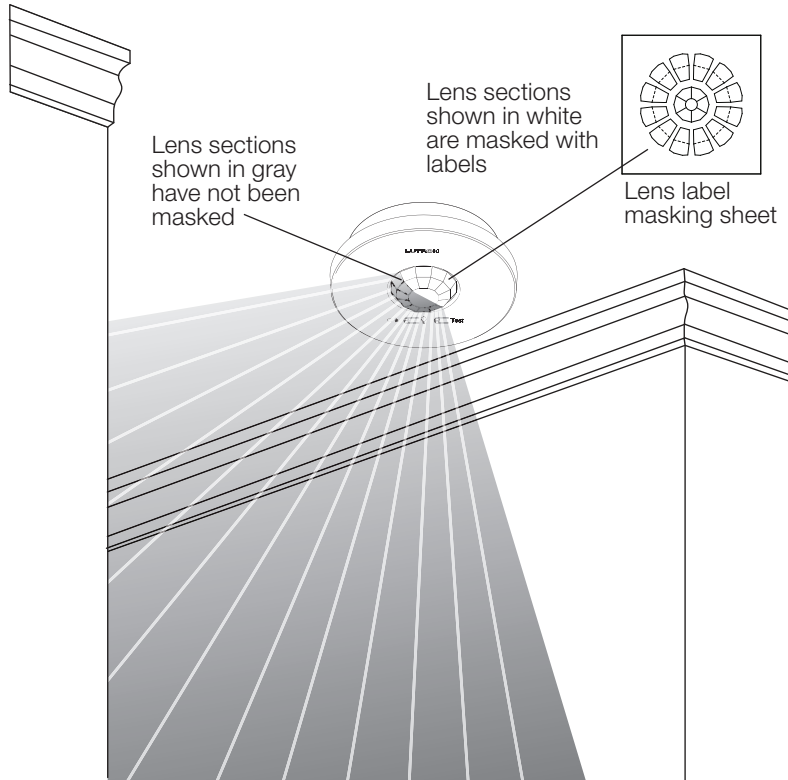

Job Name:	Model Numbers:
Job Number:	