



**Clear Connect™ Translator**  
 NXB-CCG  
 5 V $\overline{=}$  2 A  
**DC Adapter: PS-5DC-20-BL**  
 Output: 5 V $\overline{=}$  2 A  
 Typical Power Consumption\*: 5 W

**Installation Instructions**

*Please Read Before Installing*

**Features**

- Supports system setup and ensures error-free communication between system components.
- Reset button returns the Clear Connect™ Translator to factory settings.
- Ethernet port for integration and PC connectivity.
- LED feedback for RF and Ethernet communication.
- LED feedback for Power status.

**Important Notes**

**Environment**

Ambient operating temperature: 32 °F to 104 °F (0 °C to 40 °C), 0% to 90% humidity, non-condensing. Indoor use only.

**Codes**

Install in accordance with all local and national electrical codes.

**Cleaning**

To clean, wipe with a clean damp cloth. DO NOT use any chemical cleaning solutions.

**DC Adapter Power**

**NOTICE** - Using a DC adapter not rated at the proper specifications could damage the Clear Connect™ Translator and possibly overheat the DC adapter. Use only the Lutron® DC adapter listed above.

**RF Device Placement**

All dimmers, switches, keypads and shades/ draperies must be located within 30 ft (9 m) of a Clear Connect™ Translator.

**Installation**

1. Find a suitable location for the Clear Connect™ Translator.
2. Mount vertically or horizontally, as shown in the **Mounting Diagram**, using two #6 (M3) screws. When mounting, allow 7 in (177.8 mm) clearance for the antenna and ensure convenient access to the power plug. In order to achieve proper RF performance, do not mount unit in a metal enclosure.
3. Attach the DC adapter cord to the power jack on the Clear Connect™ Translator and insert the DC adapter plug into a receptacle.

**FCC/ IC Information**

This device complies with part 15 of the FCC Rules and Industry Canada license-exempt RSS standard(s). Operation is subject to the following two conditions: (1) This device may not cause interference, and (2) this device must accept any interference, including interference that may cause undesired operation. Modifications not expressly approved by Lutron Electronics Co., Inc. could void the user's authority to operate this equipment.

Note: This equipment has been tested and found to comply with the limits for a Class B digital device, pursuant to part 15 of the FCC Rules. These limits are designed to provide reasonable protection against harmful interference in a residential installation. This equipment generates, uses and can radiate radio frequency energy and, if not installed and used in accordance with the instructions, may cause harmful interference to radio communications. However, there is no guarantee that interference will not occur in a particular installation. If this equipment does cause harmful interference to radio or television reception, which can be determined by turning the equipment off and on, the user is encouraged to try to correct the interference by one or more of the following measures:

- Reorient or relocate the receiving antenna.
- Increase the separation between the equipment and receiver.
- Connect the equipment into an outlet on a circuit different from that to which the receiver is connected.
- Consult the dealer or an experienced radio/TV technician for help.

\*Typical Power Consumption test conditions: one LED on, Ethernet cable plugged in, Clear Connect™ Translator powered by the 5 V $\overline{=}$  adapter supplied.

**Dimensions**

Measurements are in inches (mm).

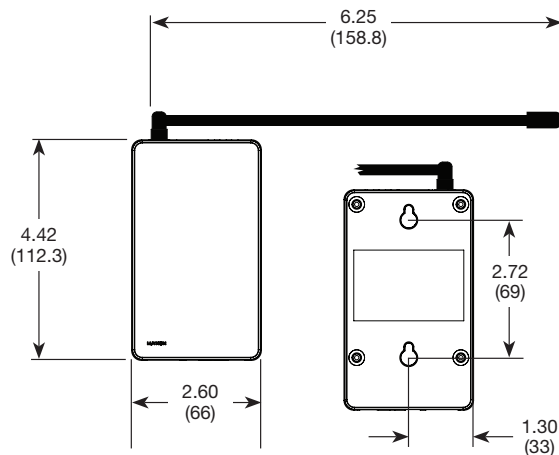

**Mounting Diagram (side view)**

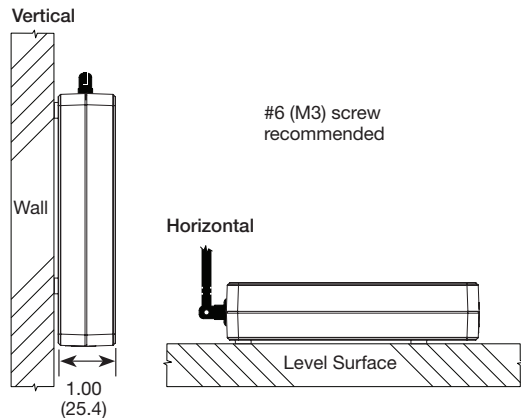

**RF Configuration**

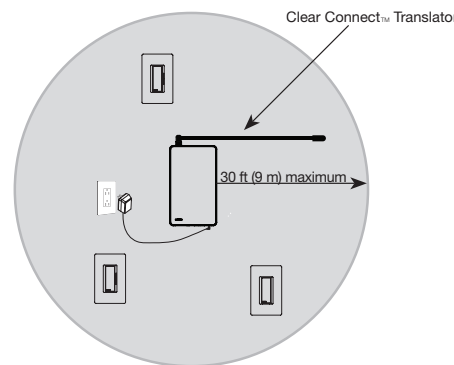

**Connection**

(top view)

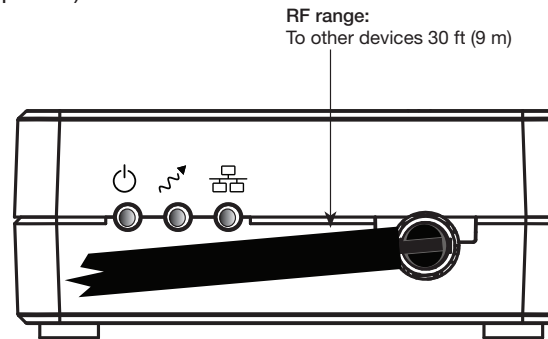

(bottom view)

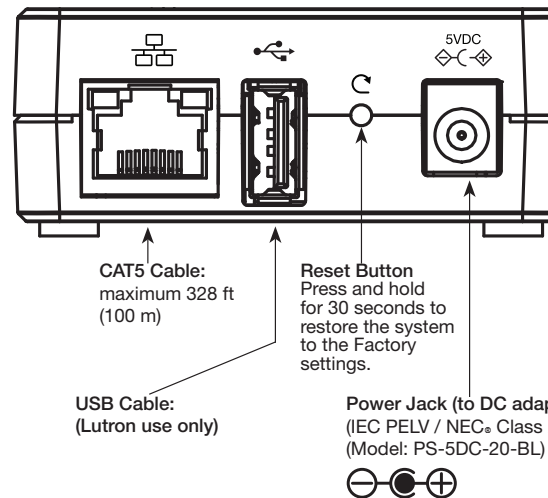

**Ethernet Pin Numbering**



Ethernet	Pin #
T+Ve	1
T-Ve	2
R+Ve	3
R-Ve	6

**Operation**

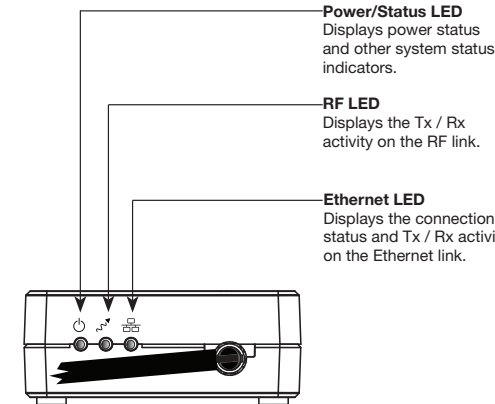

**Returning a Clear Connect™ Translator to Factory Settings**

Note: Returning a Clear Connect™ Translator to factory settings will erase all programming from it and all system devices and will require the Clear Connect™ Translator to be reprogrammed into the system.

1. Press and hold the Reset button on the Clear Connect™ Translator for 30 seconds.
2. The Power/Status LED will start flashing slowly for approximately 10 seconds after which it will start rapidly flashing for approximately 20 seconds and then remain on.
3. The Clear Connect™ Translator has been returned to factory settings.

**Warranty:** For warranty information, please see the Warranty enclosed with the product, or visit [www.lutron.com/resinfo](http://www.lutron.com/resinfo)

