

CORE

DEVELOPMENT KIT

V1.0

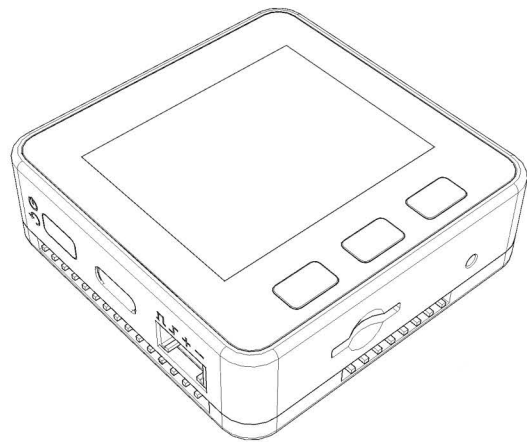

M5STACK

- ESP32
- Wi-Fi
- BLE
- 3D-Antenna
- 2 inch LCD@320X240
- 1W Speaker
- TYPE-C USB
- 2A Battery Management
- TF-Reader
- GROVE I2C
- Plastic C.A.S.E
- 3 Buttons

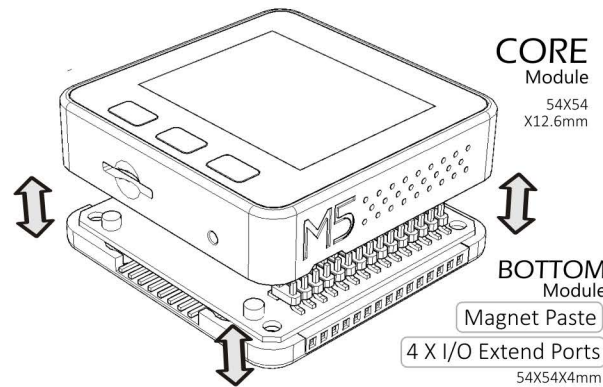

Operation

- single press **POWER ON** when using battery, and **RESET**.
- double press **POWER OFF** when using battery.

- TYPE C**
- Power Supply Charge
 - UART/Upload

- GROVE PH2.0-4
- | | | | |
|-----|-----|----|-----|
| SCL | SDA | 5V | GND |
|-----|-----|----|-----|

- MicroSD Card (TF-Card)
- ≤16GB

Bottom View

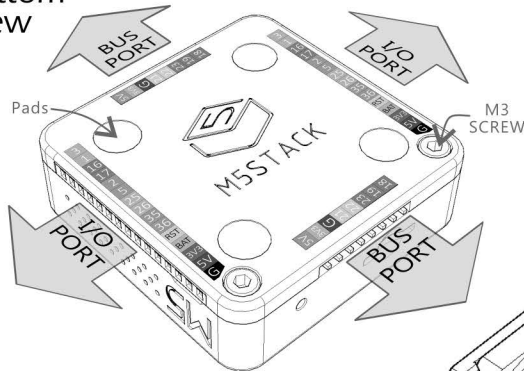

Side View

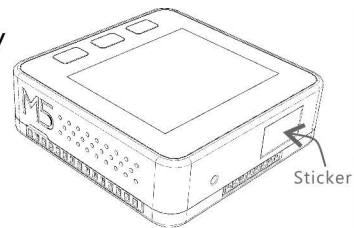

Assembly

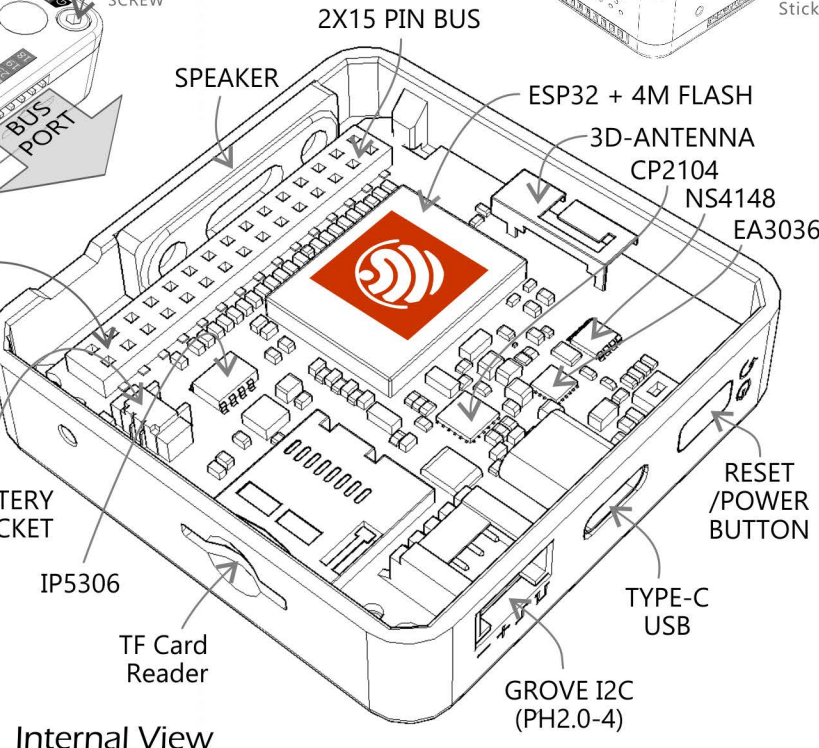
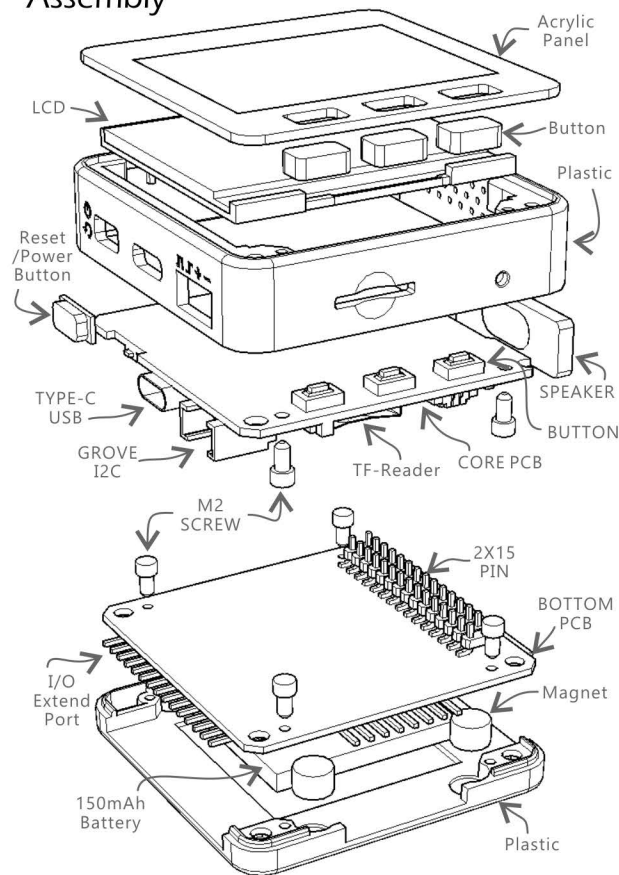

M BUS

GND	ADC	G35
GND	ADC	G36
GND	RST	EN
G23	MOSI	DAC/SPK G25
G19	MISO	DAC G26
G18	SCK	3.3V
G3	RXD0	TXD0 G1
G16	RXD2	TXD2 G17
G21	SDA	SCL G22
G2	GPIO	GPIO G5
G12	IIS_SK	IIS_WS G13
G15	IISOUT	IIS_MK G0
HPWR	IIS_IN	G34
HPWR	5V	
HPWR	BATTERY	

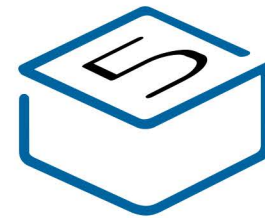

M5STACK



www.M5Stack.com

Extension

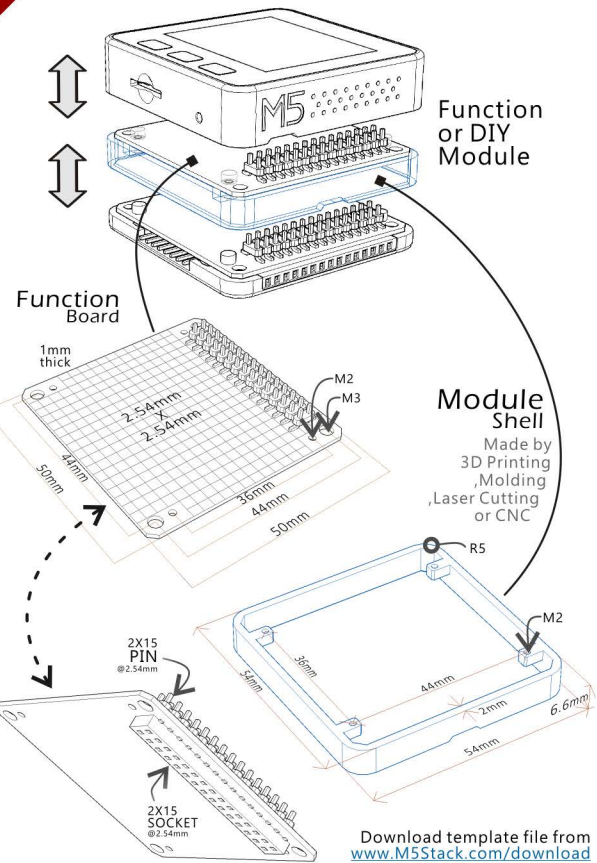

Download template file from www.M5Stack.com/download

Software Installation

1. Install Arduino IDE.
From: <https://www.arduino.cc/en/Main/Software>
2. Install M5Stack.
 - Run **Arduino IDE**, and click: **File -> Preferences**,
 - Run **Arduino IDE**, and click: **File -> Preferences**,
 - Click the button like this:

- Add the following URL into the box, and Click **OK**.
http://www.M5Stack.com/download/package_m5stack_index.json
- Click: **Tools -> Board: -> Boards Manager...**
- And Select **M5Stack-Core-ESP32**, Click **Install**.
- Done!

Hello World!

1. Select: **Tools -> Board: -> M5Stack -> Basics->Hello**
2. Click: **Files->Examples->M5Stack ->Basics->Hello**
3. Connect to PC or MAC with a usb cable.
4. Select: **Tools->Port->ComX**.
5. Click: **Sketch->Upload**.
6. Running.

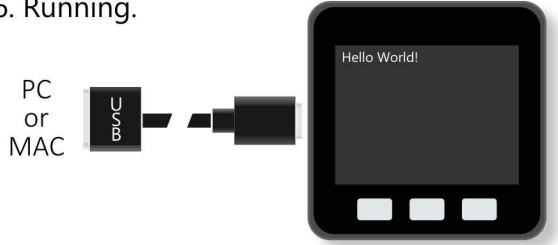

fx Function List

- SYS TEM**
 - M5.begin();
 - M5.update();
- LCD**
 - M5.Lcd.setLight(int light);
 - M5.Lcd.setCursor(int x, int y);
 - M5.Lcd.putChar(int x, int y, char ch);
 - M5.Lcd.putStr(int x, int y, string str);
 - M5.Lcd.printf(char* str,...);
 - M5.Lcd.fillScreen(uint16 color);
 - M5.Lcd.pixel(int x, int y, uint16 color);
 - M5.Lcd.line(int x1,y1,x2,y2,uint16 color);
 - M5.Lcd.drawRect(int x1,y1,x2,y2,uint16 color);
 - M5.Lcd.fillRect(int x1,y1,x2,y2,uint16 color);
- BUT TON**
 - M5.BtnA/B/C.pressed();
 - M5.BtnA/B/C.released();
 - M5.BtnA/B/C.held();
 - M5.BtnA/B/C.repeated();
- SPEA KER**
 - M5.Speaker.tone(int freq);
 - M5.Speaker.mute();
 - M5.Speaker.setBeep(int freq,int time);
 - M5.Speaker.beep();
- SER IAL**
 - M5.Serial0/2.begin(int bps);
 - M5.Serial0/2.print(char* str);
 - M5.Serial0/2.println(char* str);
 - M5.Serial0/2.read();

FCC Caution:
Any Changes or modifications not expressly approved by the party responsible for compliance could void the user's authority to operate the equipment.
This device complies with part 15 of the FCC Rules. Operation is subject to the following two conditions: (1) This device may not cause harmful interference, and (2) this device must accept any interference received, including interference that may cause undesired operation.

FCC Radiation Exposure Statement:
This equipment complies with FCC radiation exposure limits set forth for an uncontrolled environment. This equipment should be installed and operated with minimum distance 20cm between the radiator& your body.
Note: This equipment has been tested and found to comply with the limits for a Class B digital device, pursuant to part 15 of the FCC Rules. These limits are designed to provide reasonable protection against harmful interference in a residential installation. This equipment generates, uses and can radiate radio frequency energy and, if not installed and used in accordance with the instructions, may cause harmful interference to radio communications. However, there is no guarantee that interference will not occur in a particular installation. If this equipment does cause harmful interference to radio or television reception, which can be determined by turning the equipment off and on, the user is encouraged to try to correct the interference by one or more of the following measures:
—Reorient or relocate the receiving antenna.
—Increase the separation between the equipment and receiver.
—Connect the equipment into an outlet on a circuit different from that to which the receiver is connected.
—Consult the dealer or an experienced radio/TV technician for help.

Specifications

Model	CORE Kit
ESP32	240 MHz dual core Tensilica LX6 microcontroller with 600 DMIPS, Integrated 520 KB SRAM, Integrated 802.11 b/g/n-HT20 n-HT40 Wi-Fi transceiver, baseband, stack and LWIP, Integrated dual mode Bluetooth.
Input	5V @ 500mA
Interface	SPIx1, I2C(GROVE)x1, Uartx2,IISx1, TFX1
LCD	320x240 Colorful TFT LCD, ILI9341
Speaker	1W-0928
Battery	150mAh@3.7V, Bottom module-inside.
Op.Temp.	32°F to 104°F (0°C to 40°C)
Size	54x54x17mm with Bottom, 54x54x12.6mm only CORE.
C.A.S.E	Plastic(PC)
Weight	120g with Bottom, 100g only CORE.