

INSTALLATION INSTRUCTIONS

MGE Series Magic-Pak[®]

Gas Heating with Electric Cooling Unit

WARNING

Improper installation, adjustment, alteration, service, or maintenance can cause injury or property damage. Refer to this manual. For assistance or additional information, consult a qualified installer, service agency, or the gas supplier.

WARNING

For your safety, do not store or use gasoline or other flammable vapors and liquids in the vicinity of this or any other appliance. Such actions could result in property damage, personal injury, or death.

WARNING

Installation and servicing of air conditioning equipment can be hazardous due to internal refrigerant pressure and live electrical components. Only trained and qualified service personnel should install or service this equipment. Installation and service performed by unqualified persons can result in property damage, personal injury, or death.

WARNING

The unit must be installed with approved wall sleeve and grille accessories for safe operation. Improper installations could result in property damage, personal injury, or death.

CAUTION

The installation of this appliance must conform to the requirements of the National Fire Protection Association; the National Electrical Code, ANSI/NFPA No. 70 (latest edition) in the United States; the Canadian Electrical Code Part 1, CSA 22.1 (latest edition) in Canada; and any state or provincial laws or local ordinances. Local authorities having jurisdiction should be consulted before installation is made. Such applicable regulations or requirements take precedence over the general instructions in this manual.

TABLE OF CONTENTS

INSTALLATION.....	2
START-UP	12
OPERATION	13
MAINTENANCE	16
ACCESSORIES	17
WIRING DIAGRAMS	19

Manufactured By
A.A.C.
A Lennox International Inc. Company
421 Monroe Street
Bellevue, OH 44811

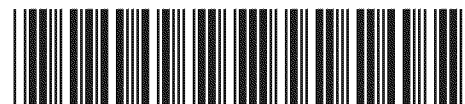

LISTED



LISTED



Certified for Canada

INSTALLATION

General

These instructions explain the recommended method of installation of the MGE gas heating with electric cooling unit and associated electrical wiring.

The MGE series are self-contained, gas-fired heating with electric cooling models. The unit design has been certified by Intertek Testing Services for compliance with the latest edition of the American National Standard – ANSI Z21.47/ National Standard of Canada – CAN/CGA-2.3 for direct vent central furnaces. The MGE models are certified to be in compliance with the latest edition of A.R.I. Standard 210. All models are design certified for heating operation when fired with natural or propane gas.

These units are not approved for mobile home applications.

These instructions, and any instructions packaged with mating components and/or accessories, should be carefully read prior to beginning installation. Note particularly any **CAUTIONS** or **WARNINGS** in these instructions and all labels on the units.

These instructions are intended as a general guide only, for use by qualified personnel and do not supersede any national or local codes in any way. Compliance with all local, state, provincial, or national codes pertaining to this type of equipment should be determined prior to installation.

⚠ WARNING

In the State of Massachusetts:

This product must be installed by a licensed Plumber or Gas Fitter. When flexible connectors are used, the maximum length shall not exceed 36". When lever-type gas shutoffs are used, they shall be T-handle type.

Inspection

Upon receipt of equipment, carefully inspect it for possible shipping damage. If damage is found, it should be noted on the carrier's freight bill. Take special care to examine the unit inside the carton if the carton is damaged. File a claim with the transportation company. If any damages are discovered and reported to the carrier do not install the unit, **as claim may be denied.**

Check the unit rating plate to confirm specifications are as ordered.

Limitations

The unit should be installed in accordance with all national and local safety codes. Limitations of the unit and appropriate accessories must also be observed.

The outdoor fan is designed to operate against no more than .10" W.C. static pressure.

Minimum and maximum operation conditions must be observed to assure maximum system performance with minimum service required. Refer to Table 1 for the application limitations of the unit.

Application Limitations			
Outdoor Ambient Air Temperature °F			
Minimum DB		Maximum DB	
Cool		Cool	Heat
65		115	75
Indoor Ambient Air Temperature °F			
Minimum		Maximum	
DB/WB	DB	DB/WB	DB
Cool	Heat	Cool	Heat
62/57	50	90/72	80

Table 1

Location

⚠ WARNING

The unit must be installed with approved wall sleeve and grille accessories for safe operation. Improper installations could result in property damage, personal injury, or death.

For information on wall sleeves and grille accessories, see **ACCESSORIES** on page 17.

The design is certified for thru-the-wall installation only. The interior portions of the unit may be surrounded by a closet with clearances to combustible material held to 0" at the sides, top, and front of the plenum. All servicing and cleaning of the unit can be performed from the front. If installed in a closet or utility room, provide 25" clearance in front for service if the door to the room is not in line with the front of the unit (see Figure 1). **Accessibility clear-**

Minimum Clearances

Clearance to combustibles is 0" at the side, top, and front of plenum. If accessibility clearances are greater than clearances to combustibles, accessibility clearances take precedence.

The front of the unit must be accessible for service. If the unit is enclosed, providing a door or access panel opposite the front of the unit is the preferred method of providing access. The door or access panel must be at least 30" wide (centered on the unit) and as tall as the unit.

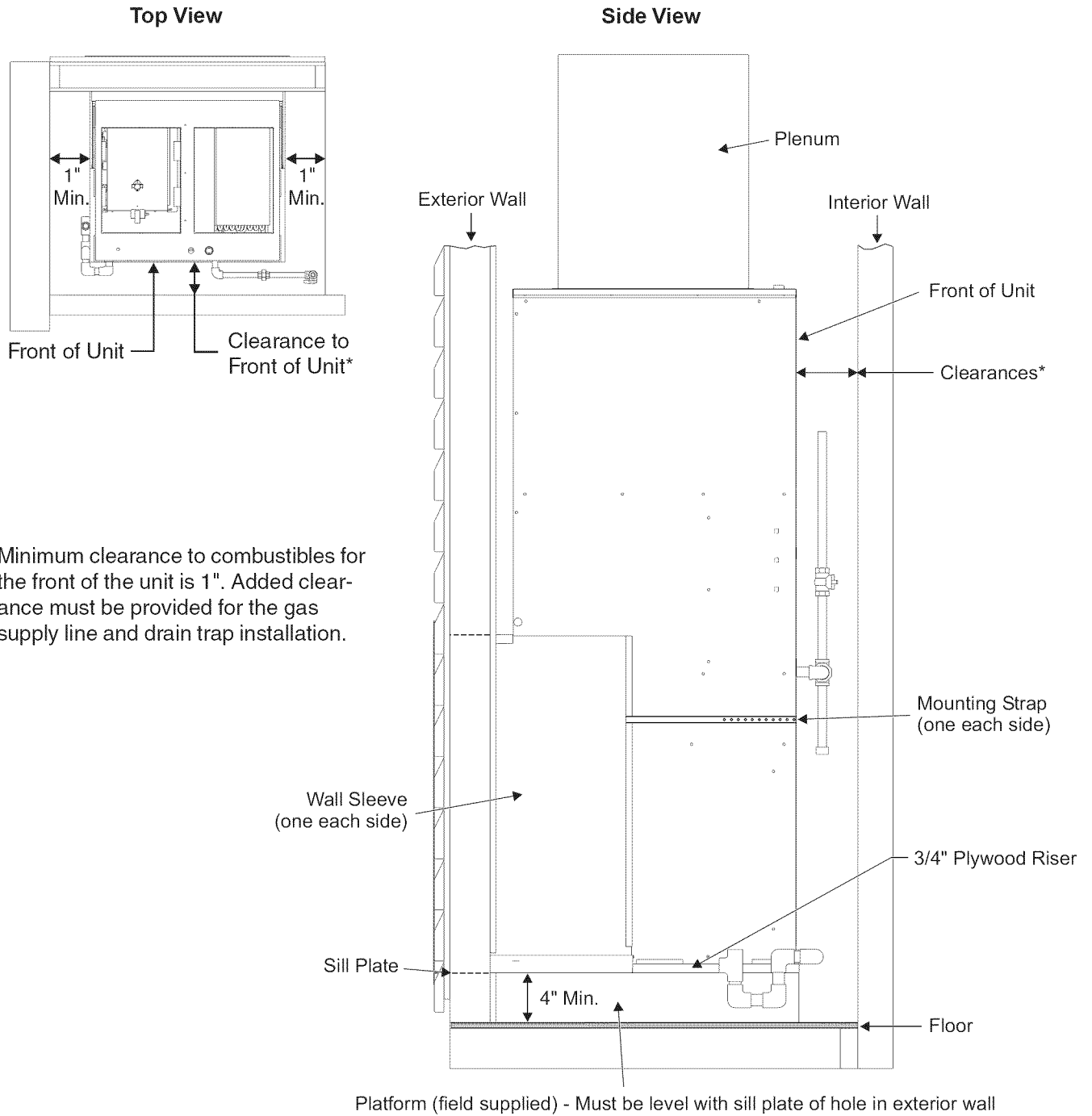

* Minimum clearance to combustibles for the front of the unit is 1". Added clearance must be provided for the gas supply line and drain trap installation.

IMPORTANT

The unit must be installed with approved wall sleeve and grille accessories for safe operation. Improper installations could result in property damage, personal injury, or death.

Wall Sleeve and Louver Kit Installed

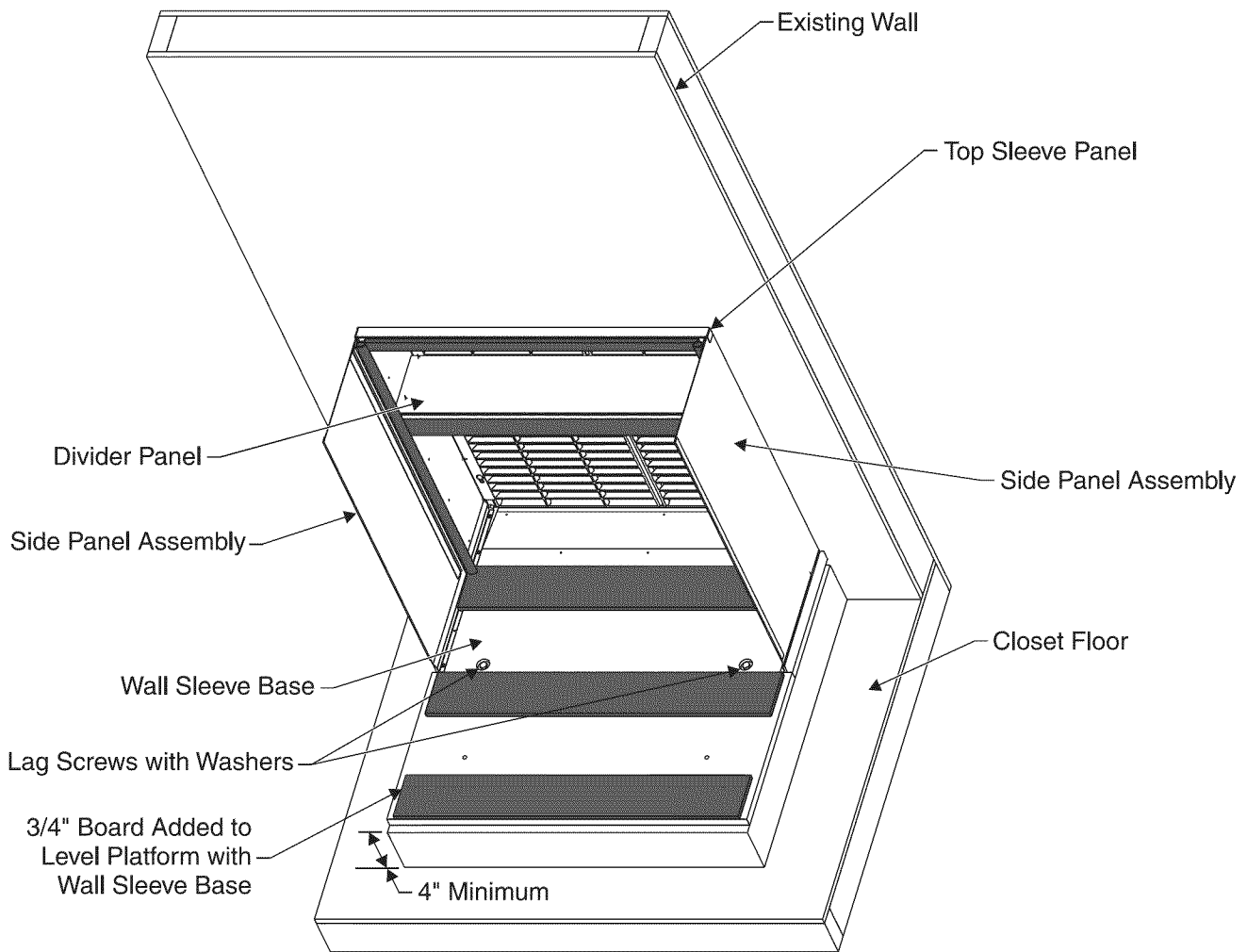

NOTE: Platform must be constructed so that it is level with sill plate of wall opening.

Figure 2

ances must take precedence over fire protection clearances.

The outside of the unit may be flush with the face of the exterior wall, and it should not be obstructed with trees, landscape materials, or building structure. Unit can be installed recessed with appropriate wall sleeve accessories. There is no minimum clearance required on locating the unit to an interior corner of a building.

If the unit is installed in a residential garage, it must be located or protected to avoid physical damage by vehicles. The unit must be installed so that no electrical components are exposed to water.

CAUTION

This unit must be installed level to allow for proper drainage of the unit base pan and indoor drain pan.

Wall Sleeve and Louver Grille Installation

Refer to installation instructions included with the wall sleeve kit and the louver grille kit along with Figure 2 for guidance in assembling and installing the wall sleeve and louver grille.

⚠ CAUTION

The sleeve is not intended as the sole support for the unit. An additional support must be provided for adequate support (see Figure 2).

Venting

The venting system is an integral part of the appliance. The venting system must not be modified in any matter other than what is specified in these instructions.

This appliance should be installed in a location such that the vent outlet is located in the following manner:

1. Distances to windows that open, building openings, or public walkways should be consistent with the National Fuel Gas Code Z223.1 or CAN/CGA-B149.1 & .2.
2. For U.S. installations, the vent system shall terminate a minimum horizontal clearance of 4' from electric meters, regulators, and relief equipment. For installations in Canada, refer to the current CAN/CGA-B149.1 & .2 or with the authorities having local jurisdiction.
3. Flue products will not cause degradation to building materials.

The unit contains an exhaust blower. The blower draws the combustion products out of the heat exchanger together with dilution air and forces the mixture from the unit to the outside. No special provisions are required for supplying air for combustion, nor is a chimney required.

The vent outlet must be extended (see **Vent Pipe Installation** on page 6).

The venting system is designed for proper operation under all weather conditions and for winds up to 40 miles per hour.

Existing Venting Systems

When an existing furnace is removed or replaced, the original venting system may no longer be sized to properly vent the attached appliances. An improperly sized venting system can result in spillage of flue products into the living space, the formation of condensate, leakage, etc. Refer to the **WARNING** box in the next column for proper test procedure.

⚠ WARNING

CARBON MONOXIDE POISONING HAZARD

Failure to follow the steps outlined below for each appliance connected to the venting system being placed into operation could result in carbon monoxide poisoning or death.

The following steps shall be followed for each appliance connected to the venting system being placed into operation, while all other appliances connected to the common venting system are not in operation:

1. Seal any unused openings in the common venting system.
2. Visually inspect the venting system for proper size and horizontal pitch, as required in the National Fuel Gas Code, ANSI Z223.1/NFPA 54 (latest edition) or the CSA B149.1, Natural Gas and Propane Installation Codes and these instructions. Determine that there is no blockage or restriction, leakage, corrosion, or other deficiencies which could cause an unsafe condition.
3. As far as practical, close all building doors and windows between the space in which the appliance(s) connected to the venting system are located and other spaces in the building.
4. Close fireplace dampers.
5. Turn on clothes dryers and any appliance not connected to the venting system. Turn on any exhaust fans, such as range hoods and bathroom exhausts, so they are operating at maximum speed. Do not operate a summer exhaust fan.
6. Follow the lighting instructions. Place the unit being inspected in operation. Adjust the thermostat so appliance is operating continuously.
7. Test for spillage from draft hood equipped appliances at the draft hood relief opening after 5 minutes of main burner operation. Use the flame of a match or candle.
8. If improper venting is observed during any of the above tests, the venting system must be corrected in accordance with the National Fuel Gas Code, ANSI Z223.1/NFPA 54 (latest edition) and/or the CSA B149.1, Natural Gas and Propane Installation Codes.
9. After it has been determined that each appliance remaining connected to the venting system properly vents when tested as outlined above, return doors, windows, exhaust fans, fireplace dampers, and any other gas-fired burning appliance to their previous conditions of use.

Vent Pipe Installation

Determining the length of the vent pipe extension is dependent upon which wall sleeve accessory is installed at the job site for each particular installation.

CAUTION

For proper operation, the vent length must be correct for the installation. The unit may not operate correctly with inadequate vent length.

1. Access vent pipe at the side of the unit that will face the outdoors.
2. The vent pipe and vent pipe extension is located to the right of the outdoor fan (see Figure 3).

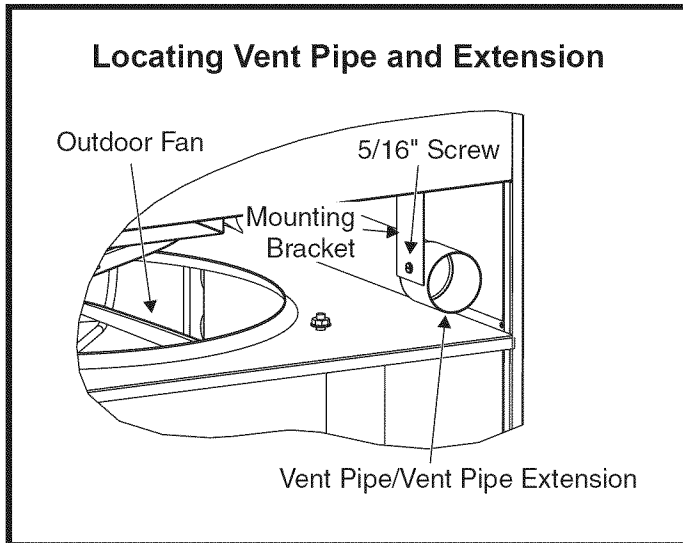

Figure 3

3. Remove the 5/16" screw used to mount the vent pipe assembly to the mounting bracket. Keep this screw.
4. Five holes have been drilled into the vent extension (see Figure 4). Four of those holes are provided so that the vent can be extended the necessary length required for the installation. The wall sleeve that is installed determines which of these clearance holes should be used. Using Table 2 and Figure 4, determine which clearance hole should be used to position the vent extension properly. Slide the vent extension outward and line up the correct clearance hole on the vent extension with the hole in the vent pipe and the hole in the mounting bracket.
5. Re-install the 5/16" screw that was removed in Step 3. Thread the screw first through the clearance hole in the mounting bracket, the proper clearance hole in the vent extension, and into the engagement hole in the vent pipe. The length of the vent pipe extension that

Determining Hole Setting

Wall Sleeve Used	Hole #	Approximate Length the Vent Extends from the Cabinet
ASLEEVE6-1, 2, 3, 4	4	5.5 inches
ASLEEVE8-1, 2, 3, 4	3	7.5 inches
ASLEEVE10-1, 2, 3, 4	2	9.5 inches
ASLEEVE12-1, 2, 3, 4	1	11.5 inches
ASLEEVE2-1, 2	0	0 inches

Table 2

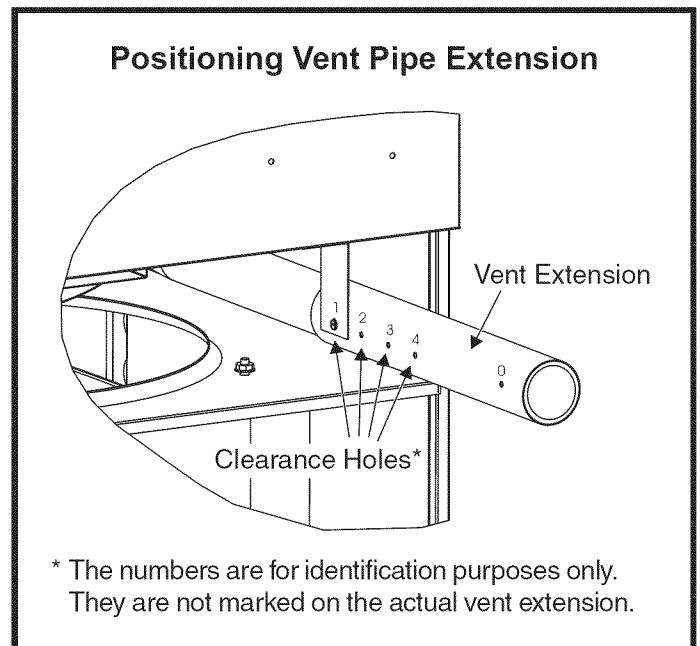

Figure 4

extends out of the cabinet should be as shown in Table 2.

Installing and Securing Unit to Wall Sleeve

Before installing and securing the unit to the wall sleeve, make sure that the proper louver kit is installed. Due to the high temperatures of the combustion products released from the gas vent, MGE gas package units require the use of either an aluminum louver kit or special MGE polypropylene louver kit (see **ACCESSORIES** on page 17).

1. Make sure the gaskets attached to the sleeve are not damaged.
2. Verify divider panel is positioned properly. Figure 5 shows the correct position for 60" and 64" tall units (flange pointing up). For 58" tall units, the divider panel should be positioned so the flange points down.

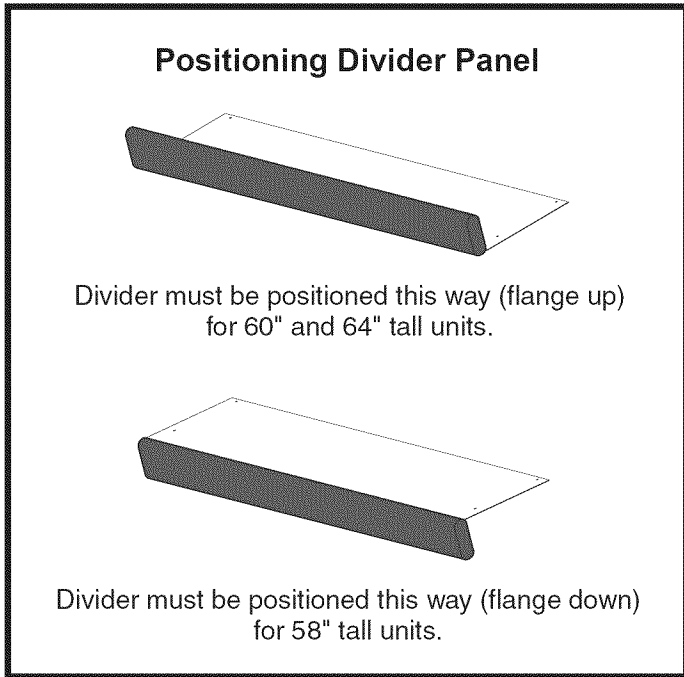

Figure 5

3. Place MGE unit into the wall sleeve. **Lift leading end of unit and walk unit onto the sleeve.** Once in the

sleeve, lower unit into position. This prevents damage to the base pads. Assume that unit is level and completely seated against the gaskets on the wall sleeve.

4. Use the two installation brackets to secure the unit to the wall sleeve (see Figure 6). The units are shipped with the brackets placed loose on the unit top panel, beneath packaging. Hook each bracket into the front edge of the wall sleeve side. Position the bracket so it can be bent around the front corner of the unit. Remove one of the two screws in that position on the unit. Line up one of the holes in the installation bracket with the screw hole and attach the bracket to the unit with that screw. Make sure to fasten tight enough that the seal is maintained. Trim off excess bracket if applicable.

Inspect the fit up of the unit to the wall sleeve. Verify that the gaskets of the wall sleeve make a complete seal to the unit paying particular attention to top and bottom corners of unit to sleeve seal. Caulk if needed.

Ductwork

Ductwork should be designed and sized according to the methods in Manual Q of the Air Conditioning Contractors of America (ACCA).

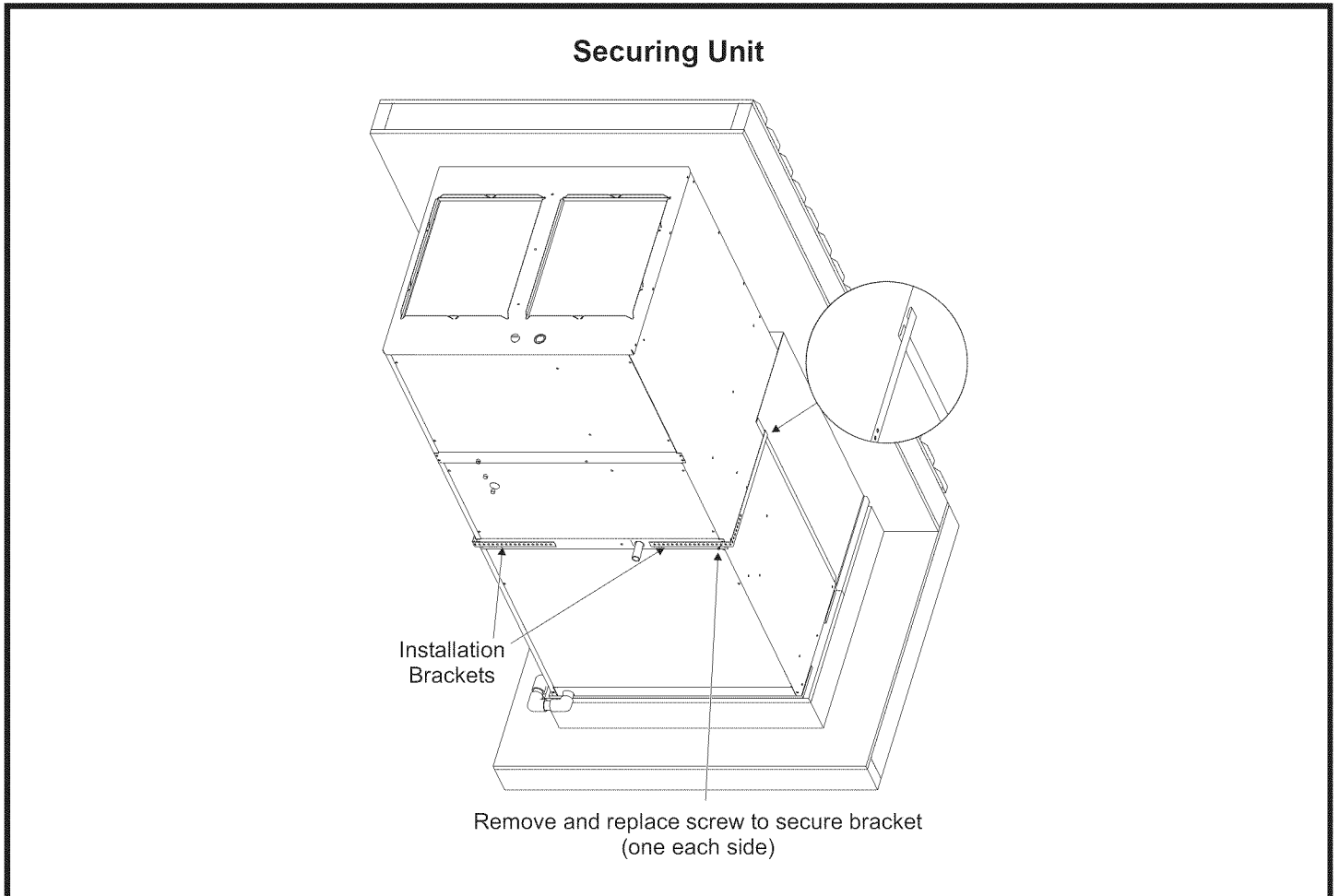

Figure 6

Check unit air supply outlet for debris before making ductwork connections.

It is recommended that supply and return duct connections at the unit be made with flexible joints. If flexible ducts are used, a 6" sheet metal starter collar is required.

The supply and return air duct systems should be designed for the CFM and static requirements of the job (see Table 3). **They should not be sized to match the dimensions of the duct connections on the unit.** The return duct should be sealed to the unit casing and terminate outside the space containing the unit.

Blower Performance

Model	Blower Speed	External Static Pressure (in. W.C. w/filter)				
		0.1	0.2	0.3	0.4	0.5
MGE10-12	Low	520	495	470	430	370
	Medium/Low	685	655	600	540	490
	Medium/High	755	715	660	595	610
	High	815	770	710	640	575
MGE10-18	Low	500	470	435	390	370
	Medium/Low	670	640	575	520	460
	Medium/High	750	690	645	575	490
	High	795	740	680	616	535
MGE10-24	Low	650	630	610	580	550
	Medium/Low	945	900	860	810	775
	Medium/High	1010	960	910	870	800
	High	1090	1030	980	930	880
MGE10-30	Low	640	620	600	575	540
	Medium/Low	940	890	860	820	785
	Medium/High	1000	960	910	875	820
	High	1110	1060	1010	960	915
MGE12-18	Low	600	580	550	515	450
	Medium/Low	820	765	720	660	595
	Medium/High	880	825	790	720	645
	High	945	885	825	760	690
MCE12-24	Low	630	610	590	560	520
	Medium/Low	905	870	830	780	735
	Medium/High	955	905	860	815	770
	High	1040	990	935	890	835
MGE12-30	Low	640	620	600	575	540
	Medium/Low	940	890	860	820	785
	Medium/High	1000	960	910	875	820
	High	1110	1060	1010	960	915

Table 3

Do not screw into the side of the drain pan, or into the indoor coil.

Air Filter

All indoor return air must be filtered. A washable filter is furnished with the unit, located in the return air opening. If return duct is installed, provisions must be made to accommodate filter servicing.

The filter should be cleaned at least three times during each of the heating and cooling seasons, or more frequently if unusual conditions are encountered. To clean the washable filter, shake filter to remove excess dirt and/or use a vacuum cleaner. Wash filter in soap or detergent water and replace after filter is dry. It is not necessary to oil the filter after washing.

If an installation is made in which it is more desirable to mount the filter exterior to the unit, in the return duct work or elsewhere, the washable filter can be used or replaced with a disposable filter. If a disposable filter is used, use the information provided in Table 4 when sizing the disposable filter.

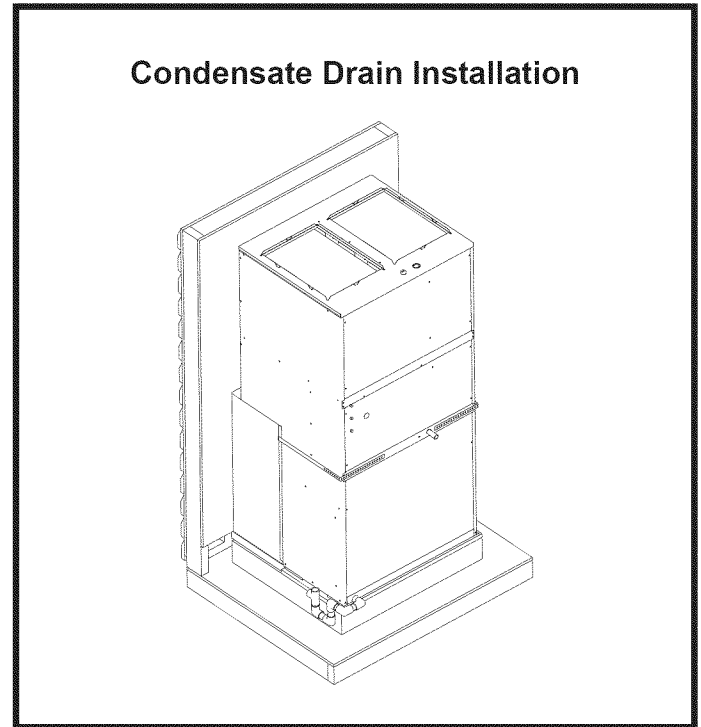

Figure 7

Minimum Required Surface Area for Disposable Filters

Model Number	Filter Area
MGE*12	192 square inches
MGE*18	288 square inches
MGE*24	384 square inches
MGE*30	480 square inches

* 10 and 12 SEER models

Table 4

Condensate Drain

Provisions must be made to properly drain the indoor and outdoor drain pans of this appliance.

The indoor drain pan drains internally into the outdoor drain. The outdoor drain connection is a 3/4" NPT to 3/4" PVC fitting (schedule 40). The drain must be trapped as shown in Figure 7. The drain line should pitch gradually downward at least 1" per 10' of horizontal run to open drain.

CAUTION

Use thread sealant on the threaded fittings. Install threaded fittings by hand only. **Do not overtorque the fittings.**

Electrical Connections

All wiring must be done in accordance with the National Electrical Code (NEC), ANSI/NFPA No. 70 (latest edition); Canadian Electrical Code CSA C22.2 Part 1 (latest edition); or local codes, where they prevail. Any alteration of internal wiring will void certification and warranty. Units are factory wired for a 230 volt power supply. If power supply is 208 volts, it will be necessary to change a wire connection on unit transformer from 240 volt terminal to 208 volt terminal as shown on the wiring diagram.

Use wiring with a temperature limitation of 75°C minimum. Run the 208 or 230 volt, 60 hertz electric power supply through a fused disconnect switch to the control box of the unit and connect as shown in the wiring diagram located on the inside of the control access panel.

The unit must be electrically grounded in accordance with local codes or, in the absence of local codes, with the National Electrical Code ANSI/NFPA No. 70 (latest edition) or CSA C22.2 Part 1 (latest edition).

Power supply to the unit must be NEC Class 1 and must comply with all applicable codes. A fused disconnect switch should be field provided for the unit. The switch must be separate from all other circuits. If any of the wire supplied with the unit must be replaced, replacement wire must be of the type shown on the wiring diagram.

Electrical wiring must be sized to minimum circuit ampacity marked on the unit. **Use copper conductors only.** Each unit must be wired with a separate branch circuit and be properly fused.

Gas Supply and Piping

Refer to unit rating plate to make sure the furnace is equipped to burn the gas supplied (natural or propane).

⚠ WARNING

Any conversion of a natural gas unit to propane gas must be done by qualified personnel using a conversion kit available from the manufacturer, following the instructions in the conversion kit. If done improperly, overfiring of the burners and improper burner operation can result. This can create carbon monoxide which could cause asphyxiation.

Gas supply piping should be installed in accordance with local codes and the regulations of the utility. Piping must be of adequate size to prevent undue pressure drop. Consult the local utility or gas supplier for complete details on special requirements for sizing gas piping.

If local codes allow the use of a flexible gas appliance connector, always use a new listed connector. Do not use a connector which has previously serviced another gas appliance.

Pipe connections must be tight, and a non-hardening pipe compound resistant to liquefied petroleum gases should be used.

Connect the gas pipe to the furnace controls providing a ground joint union as close to the controls as is possible to facilitate removal of controls and manifold. Provide a drip leg on the outside of the furnace. A manual shutoff valve shall be installed in the gas line, outside the unit, 5' above the floor, or in accordance with any local codes. A test gauge connection must be installed with a 1/8" NPT plugged tapping immediately upstream of the shutoff valve (refer to Figure 8).

The furnace must be isolated from the gas supply piping system by closing the individual manual shutoff valve during any pressure testing of the gas supply piping system at test pressure equal to or less than 1/2 psig (3.5 kPa) or 14" W.C. If the piping system is to be tested at

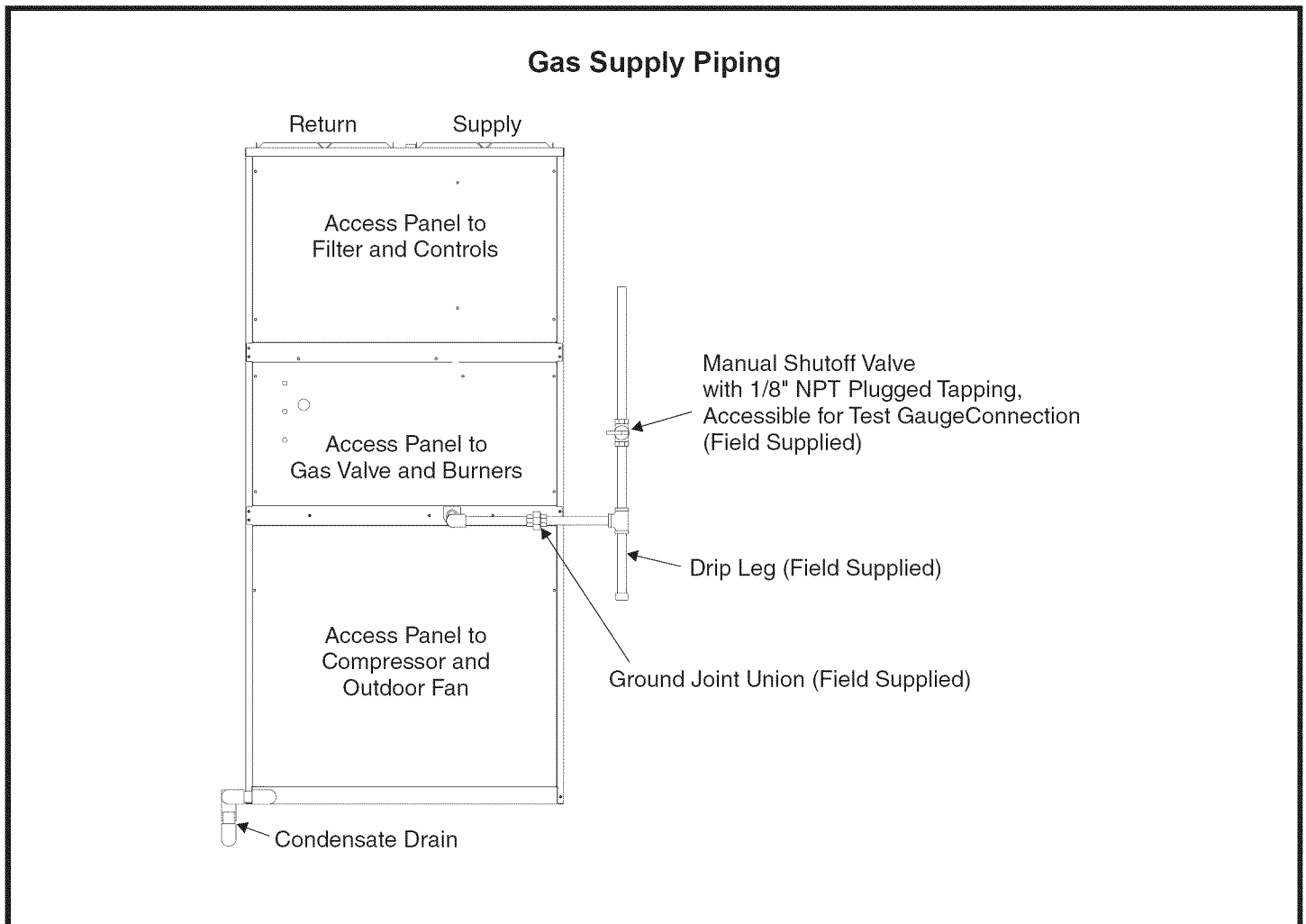

Figure 8

pressures in excess of 1/2 psig (3.5 kPa), the furnace and its appliance main gas valve must be disconnected from the gas supply piping system.

⚠ WARNING

The gas valve supplied with this furnace is rated at 1/2 psig maximum. Any higher pressure may rupture the pressure regulator diaphragm and may cause overfiring of the burners and improper burner operation. The overfiring may result in the creation of carbon monoxide which could cause asphyxiation.

After gas piping is complete, carefully check all piping connections (factory and field) for gas leaks. Use a leak detecting solution or other preferred means. Some soaps used for leak detection are corrosive to certain metals. Carefully rinse piping thoroughly after leak detection has been completed.

⚠ WARNING

FIRE OR EXPLOSION HAZARD

Failure to follow the safety warnings exactly could result in serious injury, death, or property damage.

Never test for gas leaks with an open flame. Use a commercially available soap solution made specifically for the detection of leaks to check all connections. A fire or explosion may result causing property damage, personal injury, or loss of life.

Thermostat

The room thermostat should be located on an inside wall where it will not be subject to drafts, sun exposure, or heat from electrical fixtures or appliances. Follow manufacturer's instructions enclosed with the thermostat for general installation procedures. Color-coded insulated wires (#18 AWG) should be used to connect the thermostat to the unit.

START-UP

For Your Safety Read Before Lighting

⚠ WARNING

If you do not follow these instructions exactly, a fire or explosion may result causing property damage, personal injury, or loss of life.

⚠ CAUTION

This furnace is equipped with a direct ignition control. Do not attempt to manually light the burners.

To Shut Down Unit:

1. Turn off electrical power to unit.
2. Depress and turn the gas valve knob to the "OFF" position (see Figure 9).

To Light Burners:

1. Turn off electrical power to unit.
2. Turn the thermostat to lowest setting.
3. Turn the gas valve knob to the "ON" position (see Figure 9).
4. Turn on electrical power to the unit.
5. Set the room thermostat to the desired temperature. If the thermostat "set" temperature is above room temperature after the pre-purge time expires, burners will light.

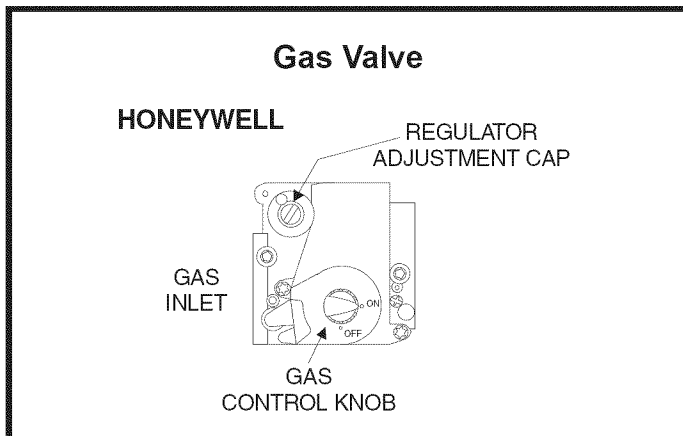

Figure 9

OPERATION

Operation of the unit is automatic and will provide heating and cooling depending on the setting of the thermostat.

Heating

1. Turn on main power supply.
2. Open manual gas shutoff valve.
3. Set thermostat system to "HEAT".
4. Set thermostat to temperature desired.

Sequence of Operation

1. Thermostat calls for heat.
2. Combustion blower starts and proper air flow is proven by the pressure switch closing.
3. Blower continues to operate for 30 seconds prior to the burners lighting.
4. Ignition control begins spark and opens gas valve. The burners are lit. Ignition is proved through flame sensor.
5. Circulating air blower starts 30 seconds after the burners light.
6. When the thermostat is satisfied, the burners and combustion blower shut off.
7. Circulating air blower will shut off 120 seconds later.

If the burners should fail to ignite, the ignition control will try to ignite the burners a total of three times. Should the burners fail to ignite within the three trials for ignition, the ignition control will lock out for 1 hour before beginning another ignition cycle. To reset the control, turn the thermostat down or off for 10 seconds and then set to desired setting. At this time, the ignition sequence will try again.

Cooling

1. Set thermostat system switch to "COOL".
2. Set thermostat to temperature desired.

NOTE: When Y is energized, the combustion blower will operate for 10 seconds. The purpose of this action is to deter insect nesting in the flue pipe.

To Shut Down Unit

For temporary or short periods of shutdown, set the thermostat system switch to "OFF". For a prolonged period of shutdown, set the thermostat system switch to

"OFF" and turn off the electrical power supply and the gas supply to the unit.

Adjustments – Heating Section

Temperature Rise

At time of installation, the temperature rise must be adjusted to be within the range specified on the unit rating plate.

Checking and Adjusting Gas Input

The gas input must not exceed the figures shown on the rating plate. The unit is equipped for rated inputs with manifold pressures of: 3.5" W.C. for natural gas and 10.0" W.C. for propane. The furnace requires conversion for use with propane (a propane conversion kit is available from the manufacturer).

The manifold pressure can be measured by removing the pipe plug in the downstream side of the gas valve and connecting a water manometer or gauge.

Only small variations in gas input may be made by adjusting the regulator. **In no case should the final manifold pressure vary more than 0.3" W.C. for natural gas or 0.7" W.C. for propane.**

To adjust the regulator, turn the adjusting screw on the regulator clockwise to increase pressure and input or counterclockwise to decrease pressure and input.

CAUTION

The furnace rate must be within +/- 2% of the appliance rating input.

For Natural Gas: Check the furnace rate by observing the gas meter, when available, making sure all other gas appliances are turned off. The test hand on the meter should be timed for at least one revolution. Note the number of seconds for one revolution.

$$\text{BTU/HR INPUT} = \frac{\text{Cubic Feet Per Revolution}}{\text{\# Seconds Per Revolution}} \times 3600 \times \text{Heating Value}$$

The heating value of the gas can be obtained from the local utility company.

For Propane Gas: The only check for the furnace rate is to properly adjust the manifold pressure using a manometer and the information found in Table 5 on page 14. Typical manifold set point for installations at altitudes from 0 to 4500' above sea level is 10.0" W.C.

Adjustments – Cooling Section

No adjustments are required or should be attempted regarding any of the components of the cooling system.

Manifold Pressure vs. Altitude

Altitude (ft.)	Heating Value* (BTU/ft ³)	Manifold Pressure (in. W.C.)	Input Factor
2000	948	3.50	0.9666
3000	914	3.50	0.9499
4000	881	3.50	0.9332
4500	865	3.50	0.9249
5000	849	3.29	0.8900
5500	833	3.27	0.8790
6000	818	3.25	0.8680
6500	802	3.23	0.8570
7000	787	3.21	0.8460
7500	771	3.19	0.8350

* Consult local utility for actual heating value.

Furnace Input = Input Factor x Nameplate Input

Above 7500 feet, call Technical Services at 1-800-448-5872 ext. 2610.

Table 5

The system should be checked to see that none of the wiring is loose or missing.

System Performance

For maximum performance of the cooling system, the operating temperatures and pressures should be checked and superheat determined at Standard ARI test conditions of 82°F outdoor – 80°F indoor dry bulb/67°F wet bulb. If superheat measured deviates from the values given in Table 6, refrigerant charge should be adjusted accordingly for maximum performance.

Blower

The unit contains a direct-drive, multispeed blower. The proper speeds have been preset at the factory for heating and cooling. Refer to the wiring diagram for recommended heating/cooling speeds for specific models. Direct-drive blower motors are permanently lubricated and do not require oiling.

Blower Operation

Continuous operation of the air handling blower will be obtained if the thermostat fan switch is set to "ON". With the thermostat fan switch set to "AUTO", the air handling blower will cycle corresponding with the thermostat cycling.

Suction Superheat

Magic-Pak® Model	Suction Superheat @ ARI Conditions 82° OD 80° IDDB/67° IDWB
MGE10-12	18° - 20°F
MGE10-18	16° - 18°F
MGE10-24	18° - 20°F
MGE10-30	16° - 18°F
MGE12-18	10° - 12°F
MGE12-24	12° - 14°F
MGE12-30	10° - 12°F

Table 6

Fan Control

The blower will start approximately 30 seconds after the burners ignite and will stop approximately 120 seconds after the thermostat is satisfied. The time delay is preset at the factory and timing cannot be adjusted.

When the thermostat system switch is set for "COOL", the blower will start 5 seconds after the thermostat calls for cooling and will stop 90 seconds after the thermostat is satisfied.

A fan switch is provided on the thermostat which will bring the blower on for continuous operation when the switch is set for "ON".

Limit Control

A fixed temperature limit control is provided which will shut off the gas to the burners if the unit is overheated for any reason. The control must not be adjusted or relocated.

Rollout Switch

If for any reason the exchanger were to become blocked, there is a temperature sensitive switch located above the burners that will turn off the burners. After correcting the problem, this switch must be manually reset by pressing the button on top of it.

High Altitude

In both the United States and Canada, this unit is approved for operation at altitudes from 0 to 4500 feet above sea level without any required modifications. From 4500 to 7500 feet, the gas manifold pressure needs to be adjusted according to the information shown in Table 5. To adjust the

manifold pressure, refer to previous section **Checking and Adjusting Gas Input** on page 13. For installations above 7500 feet, call Technical Service at 1-800-448-5872 ext. 2610 for assistance.

Installation and Operation in Extremely Cold Weather Areas

In areas where extremely cold outdoor temperatures (below – 20°F) can be expected, some additional installation and operating precautions should be taken. The following precautions are designed to prevent possible vent system ice blockage that could result in safety shutdown of the burners:

1. Adjust to the highest achievable temperature rise within the rise and static pressure ranges specified on the rating plate. Depending on specific model, it may be possible to change to a lower heating blower speed tap to get a higher temperature rise. This also increases comfort.
2. Make sure there are no leaks of outside air into the return air system.
3. Keep the outside louver grille as free as possible of any ice that may form and obstruct the flue outlet.

MAINTENANCE

⚠ WARNING

Disconnect all electrical power to the unit before conducting any maintenance procedures. Failure to disconnect the power could result in personal injury or death.

Burners

The burners can be removed for cleaning or changing orifices. To remove the burners:

1. Disconnect electrical service and turn off gas to the appliance.
2. Disconnect the high voltage (spark plug) wire and the flame sensor wire (S1) from the ignition control.
3. Remove spark and sense rods.
4. Remove the four screws that mount the burner right side plate (houses the spark/sense probes).
5. Carefully remove the burner right side plate.
6. Burners are now exposed and can be individually removed from assembly by removing the two screws that hold each burner in the burner rack.

Burners can be cleaned using a bottle brush.

Orifices are threaded into the gas manifold and can be removed by unscrewing.

When replacing the burner tray assembly, take care in installing the sense and spark rods back into the burner plate. Reconnect the spark and sense wires.

Heat Exchanger

The heat exchanger should be inspected periodically and cleaned if necessary. If cleaning is necessary, use a stiff brush with a wire handle to remove scale and soot. While cleaning the heat exchanger, the vent extension tube should also be cleaned. Remove the four screws on the combustion blower mounting plate and take out the blower. Use a brush to clean the vent extension tube.

Cooling System

The refrigeration system normally requires no maintenance since it is a closed, self-contained system. Periodic maintenance is limited to:

- Cleaning the air filter. Follow directions noted on the filter and label attached to the access panel.
- Cleaning the condenser coil if covered with any foreign material, lint, leaves, or other obstructions.

ACCESSORIES

Kit No.	Description	Used With
ALVRPWHTMGE-1	Polypropylene Louver Kit (White)	MGE10-12, 18, 24, & 30/MGE12-18 & 24
ALVRPWHTMGE-2	Polypropylene Louver Kit (White)	MGE12-30
ALVRPSANMGE-1	Polypropylene Louver Kit (Sandstone)	MGE10-12, 18, 24, & 30/MGE12-18 & 24
ALVRPSANMGE-2	Polypropylene Louver Kit (Sandstone)	MGE12-30
ALVRPBGEMGE-1	Polypropylene Louver Kit (Beige)	MGE10-12, 18, 24, & 30/MGE12-18 & 24
ALVRPBGEMGE-2	Polypropylene Louver Kit (Beige)	MGE12-30
ALVRPTPSTMGE-1	Polypropylene Louver Kit (Taupestone)	MGE10-12, 18, 24, & 30/MGE12-18 & 24
ALVRPTPSTMGE-2	Polypropylene Louver Kit (Taupestone)	MGE12-30
ALVRPCSTMMGE-1	Polypropylene Louver Kit (Custom Color*)	MGE10-12, 18, 24, & 30/MGE12-18 & 24
ALVRPCSTMMGE-2	Polypropylene Louver Kit (Custom Color*)	MGE12-30
ALVRAL-1	Extruded Aluminum Louver Kit	MGE10-12, 18, 24, & 30/MGE12-18 & 24
ALVRAL-2	Extruded Aluminum Louver Kit	MGE12-30
ALVRAL-3	Extruded Aluminum Louver Kit (45" Height)	MGE10-12, 18, 24, & 30/MGE12-18 & 24
ALVRAL-4	Extruded Aluminum Louver Kit (45" Height)	MGE12-30
ALVRAL-5	Extruded Aluminum Louver Kit (50" Height)	MGE10-12, 18, 24, & 30/MGE12-18 & 24
ALVRAL-6	Extruded Aluminum Louver Kit (50" Height)	MGE12-30
ASLEEVE2-1	2" Wall Sleeve Kit	MGE10-12, 18, 24, & 30/MGE12-18 & 24
ASLEEVE2-2	2" Wall Sleeve Kit	MGE12-30
ASLEEVE6-1	6" Wall Sleeve Kit	MGE10-12, 18, 24, & 30/MGE12-18 & 24
ASLEEVE6-2	6" Wall Sleeve Kit	MGE12-30
ASLEEVE8-1	8" Wall Sleeve Kit	MGE10-12, 18, 24, & 30/MGE12-18 & 24
ASLEEVE8-2	8" Wall Sleeve Kit	MGE12-30
ASLEEVE10-1	10" Wall Sleeve Kit	MGE10-12, 18, 24, & 30/MGE12-18 & 24
ASLEEVE10-2	10" Wall Sleeve Kit	MGE12-30
ASLEEVE12-1	12" Wall Sleeve Kit	MGE10-12, 18, 24, & 30/MGE12-18 & 24
ASLEEVE12-2	12" Wall Sleeve Kit	MGE12-30
ASLEEVE6-3	6" Wall Sleeve for 45" Louver	MGE10-12, 18, 24, & 30/MGE12-18 & 24
ASLEEVE8-3	8" Wall Sleeve for 45" Louver	MGE10-12, 18, 24, & 30/MGE12-18 & 24
ASLEEVE10-3	10" Wall Sleeve for 45" Louver	MGE10-12, 18, 24, & 30/MGE12-18 & 24
ASLEEVE12-3	12" Wall Sleeve for 45" Louver	MGE10-12, 18, 24, & 30/MGE12-18 & 24
ASLEEVE6-4	6" Wall Sleeve for 45" Louver	MGE12-30
ASLEEVE8-4	8" Wall Sleeve for 45" Louver	MGE12-30
ASLEEVE10-4	10" Wall Sleeve for 45" Louver	MGE12-30
ASLEEVE12-4	12" Wall Sleeve for 45" Louver	MGE12-30
AFILTMP-1	Outdoor Coil Filter Kit	All Models
ALPKT612-1	Propane Conversion Kit	All Models

* Customer specified color

Wall Sleeve Dimensions (in.)

Kit No.	A	B	C	D
ASLEEVE2-1	2	29	29-1/8	29-1/8
ASLEEVE2-2	2	32-3/4	32-7/8	29-1/8
ASLEEVE6-1	6	29	29-1/8	29-1/8
ASLEEVE6-2	6	32-3/4	32-7/8	29-1/8
ASLEEVE6-3	6	45	45-1/8	29-1/8
ASLEEVE6-4				
ASLEEVE8-1	8	29	29-1/8	29-1/8
ASLEEVE8-2	8	32-3/4	32-7/8	29-1/8
ASLEEVE8-3	8	45	45-1/8	29-1/8
ASLEEVE8-4				
ASLEEVE10-1	10	29	29-1/8	29-1/8
ASLEEVE10-2	10	32-3/4	32-7/8	29-1/8
ASLEEVE10-3	10	45	45-1/8	29-1/8
ASLEEVE10-4				
ASLEEVE12-1	12	29	29-1/8	29-1/8
ASLEEVE12-2	12	32-3/4	32-7/8	29-1/8
ASLEEVE12-3	12	45	45-1/8	29-1/8
ASLEEVE12-4				

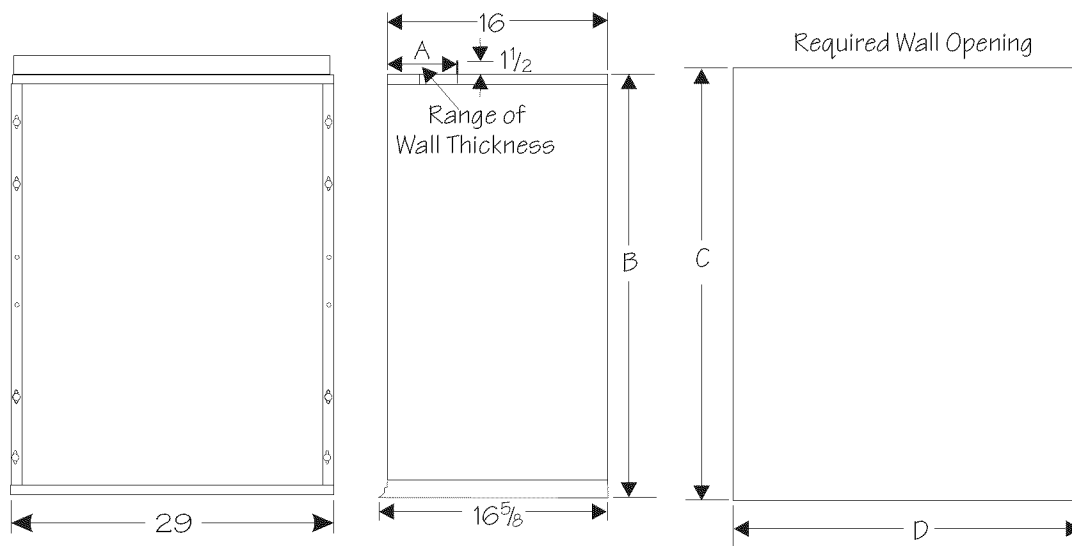

NOTE: Bottom surface of wall opening must be at least 4" off the floor.

⚠ WARNING

The unit must be installed with approved wall sleeve and grille accessories for safe operation. Improper installations could result in property damage, personal injury, or death.

Figure 10

- LINE VOLTAGE - FACTORY
- - - LINE VOLTAGE - FIELD
- LOW VOLTAGE - FACTORY
- - - LOW VOLTAGE - FIELD

NOTE:
IF ANY OF THE ORIGINAL WIRE IS REPLACED THE SAME SIZE AND TYPE WIRE MUST BE USED.

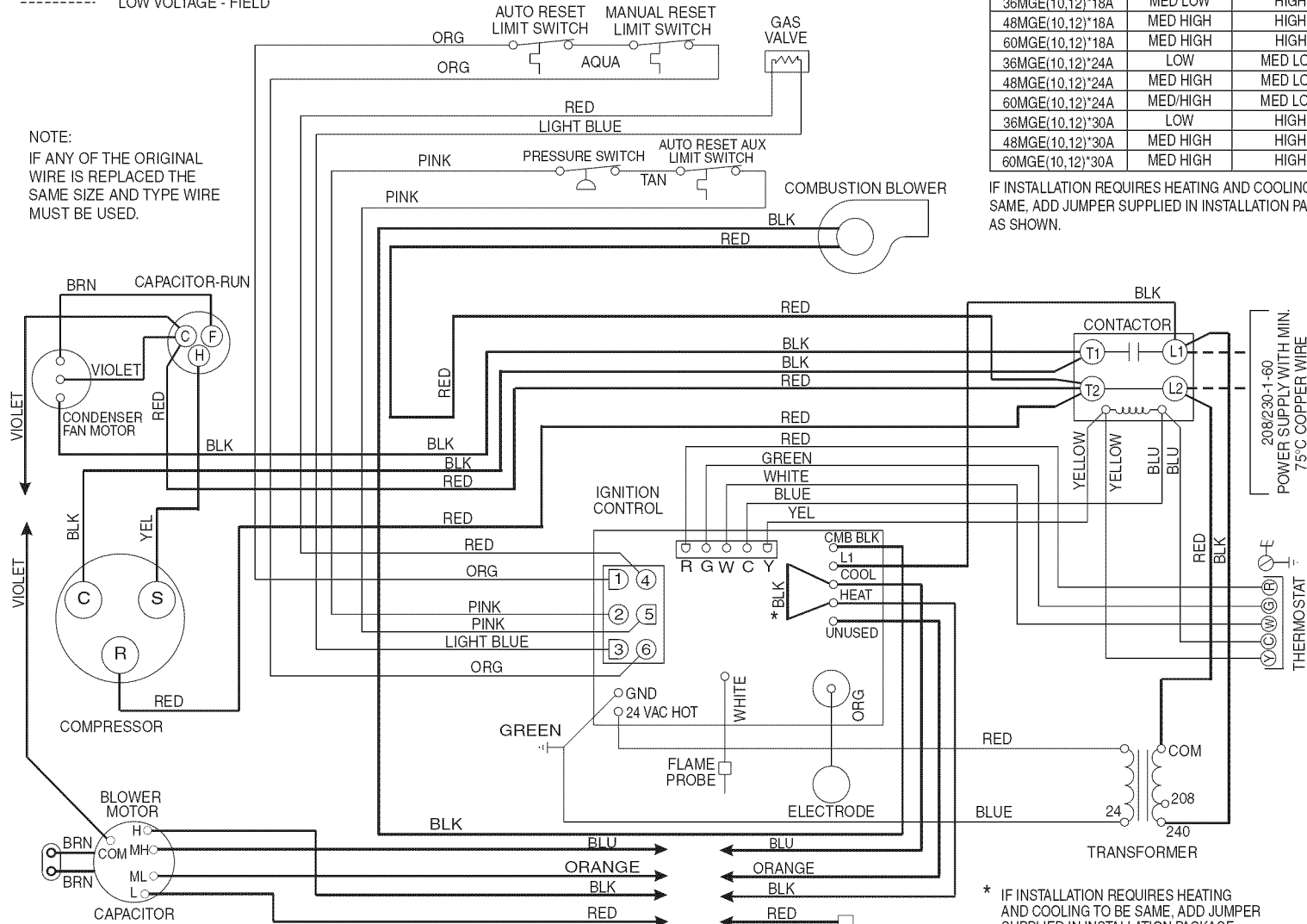

MODEL NO.	HTG SPD	CLG SPD
36MGE(10.12)*12A	MED LOW	LOW
36MGE(10.12)*18A	MED LOW	HIGH
48MGE(10.12)*18A	MED HIGH	HIGH
60MGE(10.12)*18A	MED HIGH	HIGH
36MGE(10.12)*24A	LOW	MED LOW
48MGE(10.12)*24A	MED HIGH	MED LOW
60MGE(10.12)*24A	MED/HIGH	MED LOW
36MGE(10.12)*30A	LOW	HIGH
48MGE(10.12)*30A	MED HIGH	HIGH
60MGE(10.12)*30A	MED HIGH	HIGH

IF INSTALLATION REQUIRES HEATING AND COOLING TO BE SAME, ADD JUMPER SUPPLIED IN INSTALLATION PACKAGE AS SHOWN.

208/230-1-60
POWER SUPPLY WITH MIN.
75°C COPPER WIRE

LED DIAGNOSTIC CONDITIONS:
SLOW FLASH = NORMAL OPERATION, NO CALL FOR HEAT
FAST FLASH = NORMAL OPERATION, CALL FOR HEAT
2 FLASH = SYSTEM LOCKOUT - FAILED TO DETECT OR SUSTAIN FLAME
3 FLASH = PRESSURE SWITCH OPEN OR CLOSED

4 FLASH = HIGH LIMIT OR ROLLOUT SWITCH OPEN
5 FLASH = FLAME SENSED AND GAS VALVE NOT ENERGIZED
STEADY = INTERNAL FAILURE (MICRO-CONTROLLER FAILURE; SELF-CHECK)

* IF INSTALLATION REQUIRES HEATING AND COOLING TO BE SAME, ADD JUMPER SUPPLIED IN INSTALLATION PACKAGE AS SHOWN.

SEE CHART FOR WIRING

**Connection Diagram
Part #46976-005**

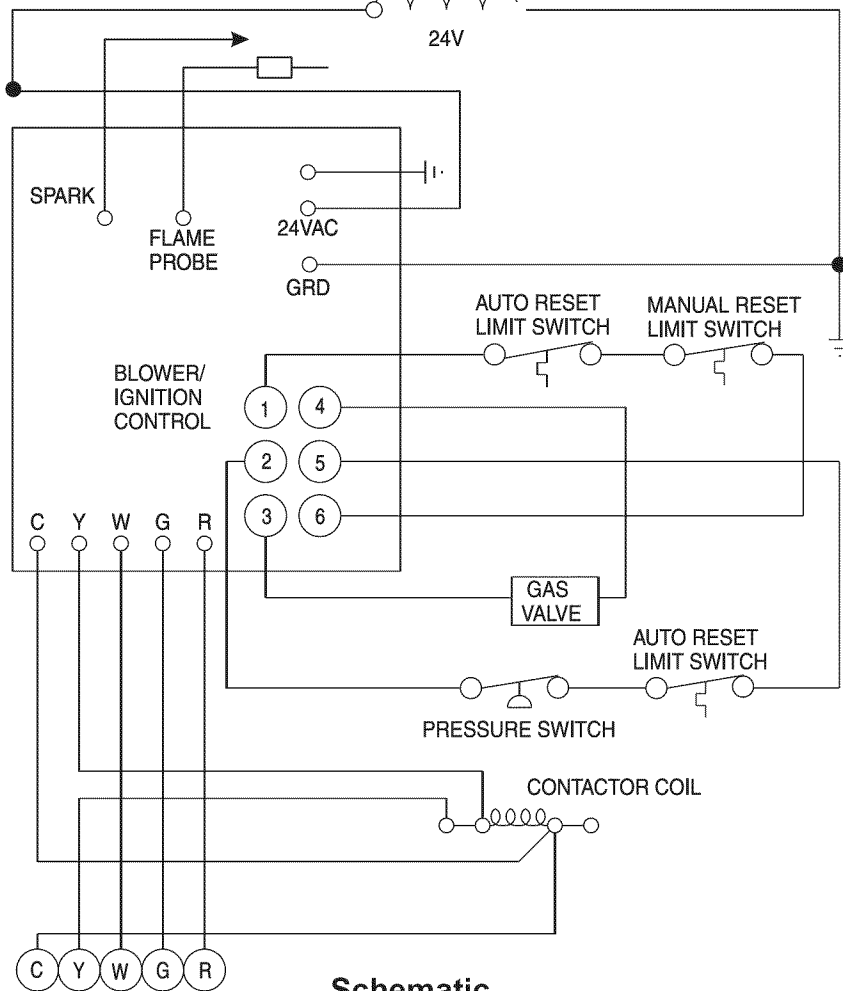
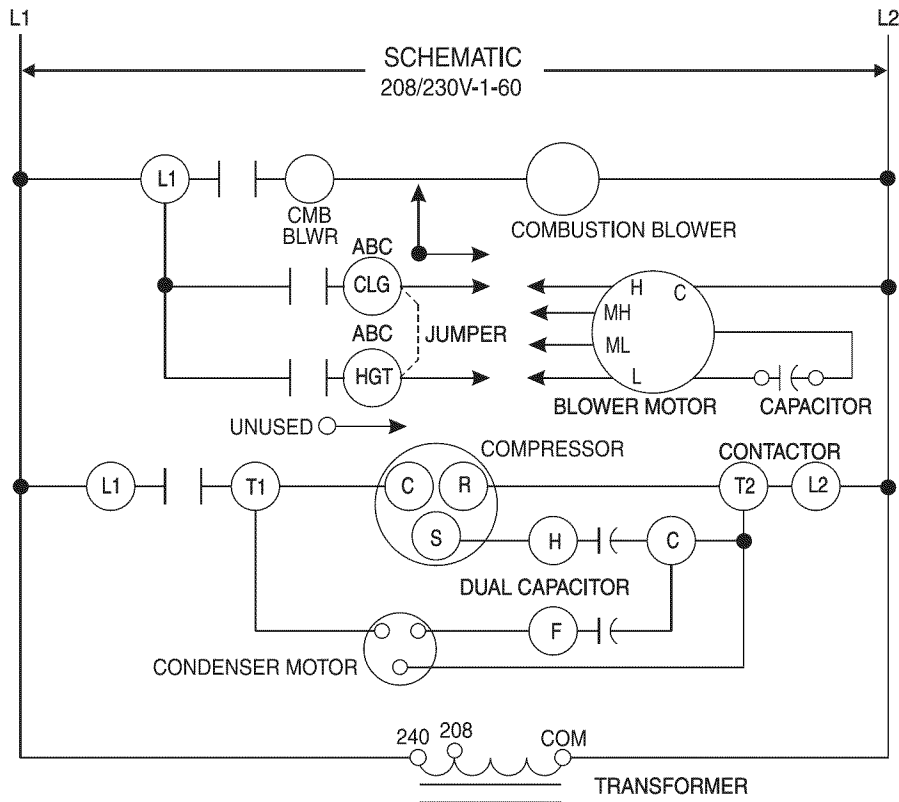

Schematic
Part #46976-005