

Instruction

16021977

6 2727490

Sheet

Description: Lip Seal Kit

Repair Part Number: 12002022

Kit includes:

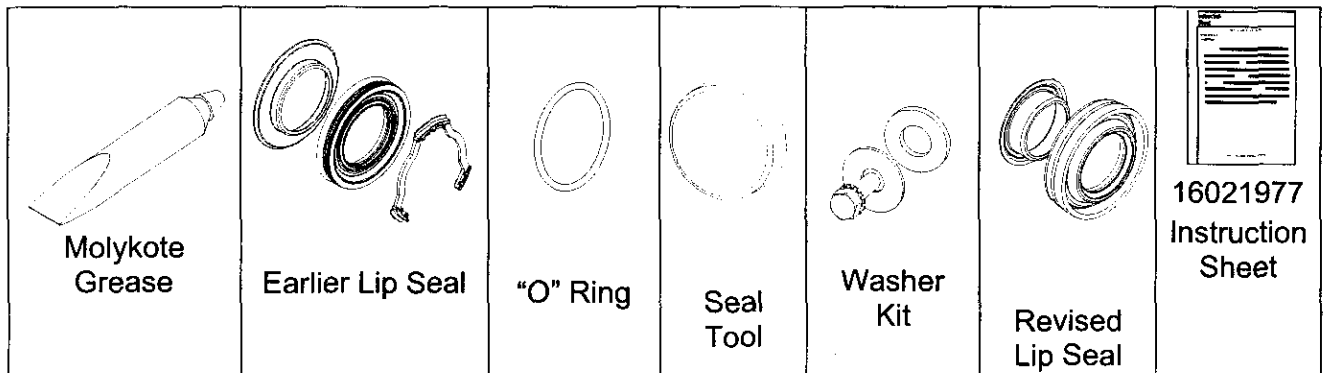

WARNING

To avoid risk of electrical shock, personal injury or death; disconnect electrical power before servicing.

Tools:

1. 5/16" Nut Driver
2. 9/16", 1/2" Socket and Ratchet
3. Phillips Screwdriver
4. Flat Blade Screwdriver
5. 35-2968 Spanner (Used for leverage to remove rear pulley).
6. Torque Wrench

Explanation:

A multi-lipped water seal is positioned on the Spinner Support Shaft leading to the Outer Tub Bearings. This prevents water from inside the tub from reaching the bearings. Removing the Spin Basket and Spinner Support Shaft assembly will allow access to the water seal. There are 2 different style spinner shafts each requiring different seals.

Seal Identification:

Examine the existing seal system in the washer and look for the following.

EARLIER SEAL AND SHAFT:

1. Steel washer seal has rubber molded on the bottom side.
2. No "O"-Ring present on support shaft.
3. A-frame plastic spacer behind seal.

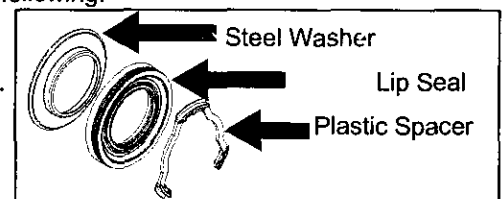

REVISED SEAL AND SHAFT:

1. "O"-Ring present on support shaft.
2. No A-frame plastic spacer present.
3. No rubber on the bottom side of steel washer.

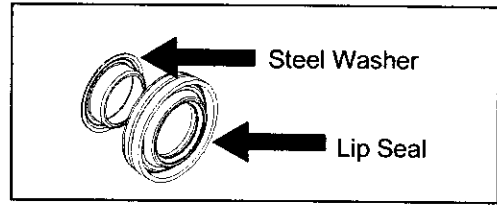

Procedure:

1. Disconnect power to the machine.
2. Remove the front panel, top cover and front shroud.

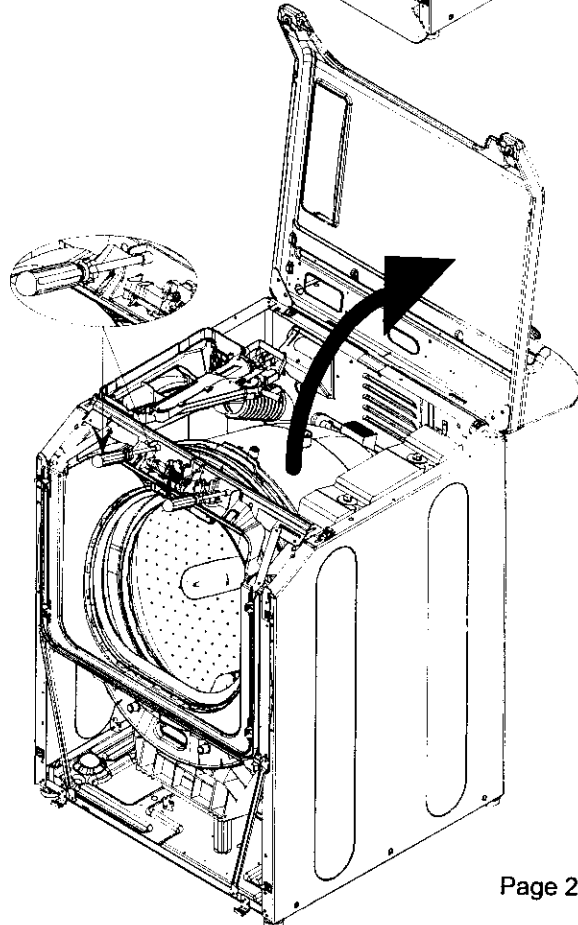
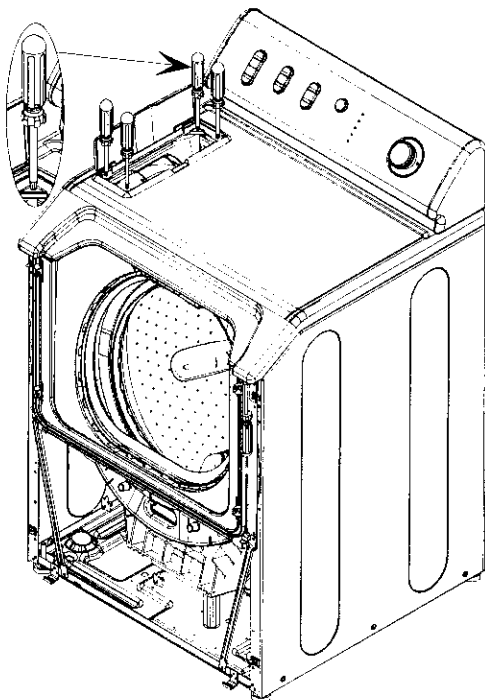
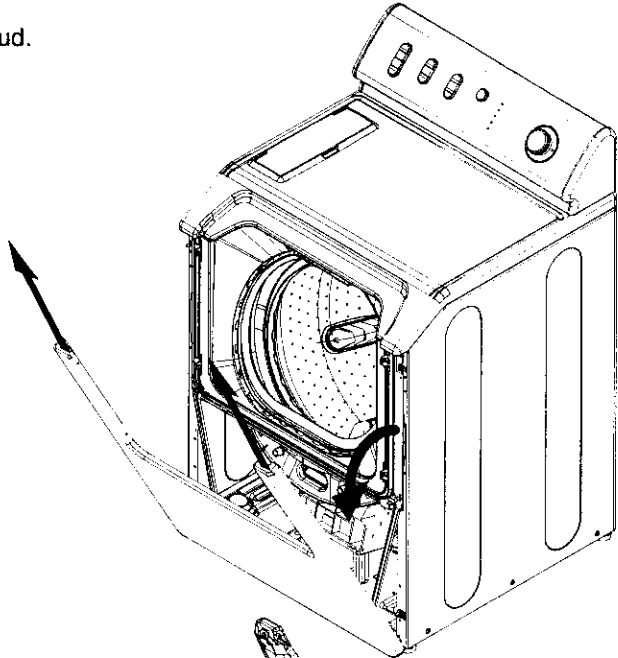
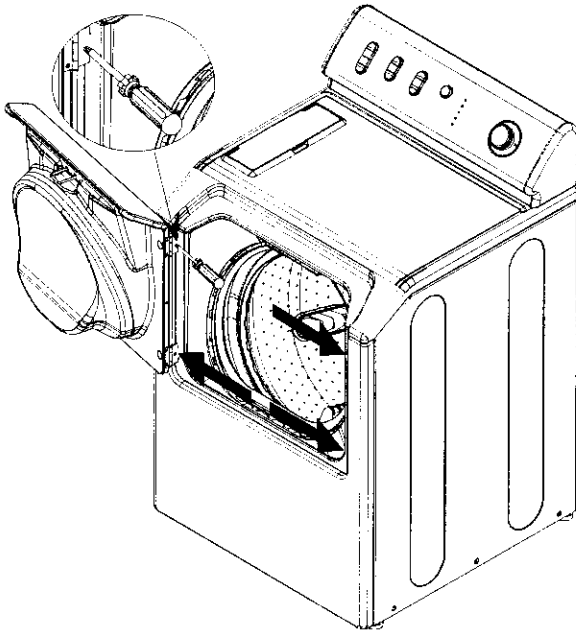

3. Remove Shroud Support Brackets.

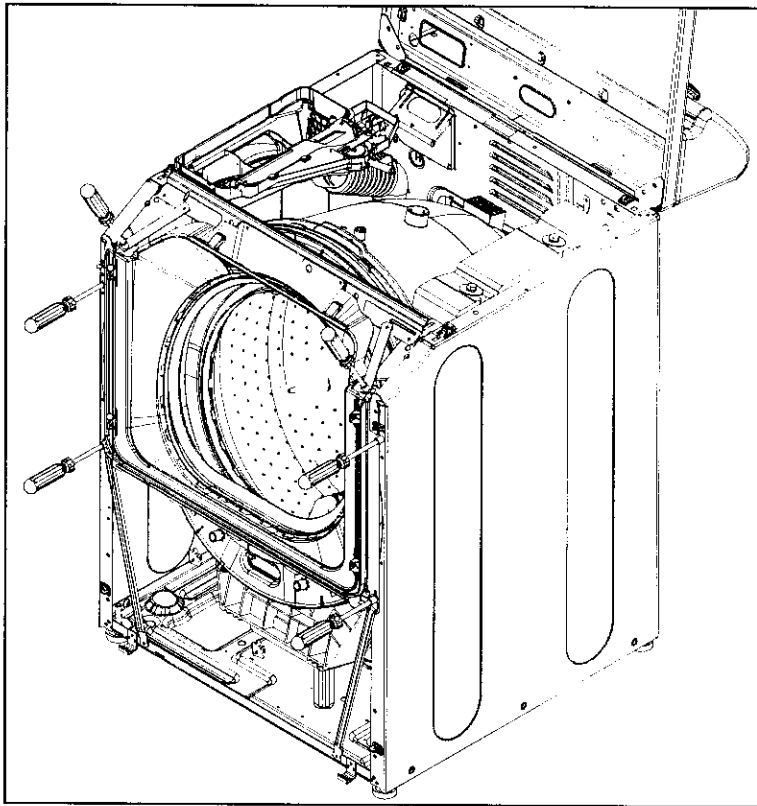

4. Remove the Outer Tub Cover.

- a. If the washer has a heater installed into the tub cover, remove the wires from the tub cover and the wire retainer screws.
- b. Using a flat bladed screwdriver, slide the screwdriver under the clip and pry to remove the clip. Remove the remaining clips from the outer tub cover.
- c. Carefully remove the cover from the outer tub.

5. Remove Drive Pulley by standing over top of washer, while leaning the Outer Tub forward. Roll the drive belt off the pulley.

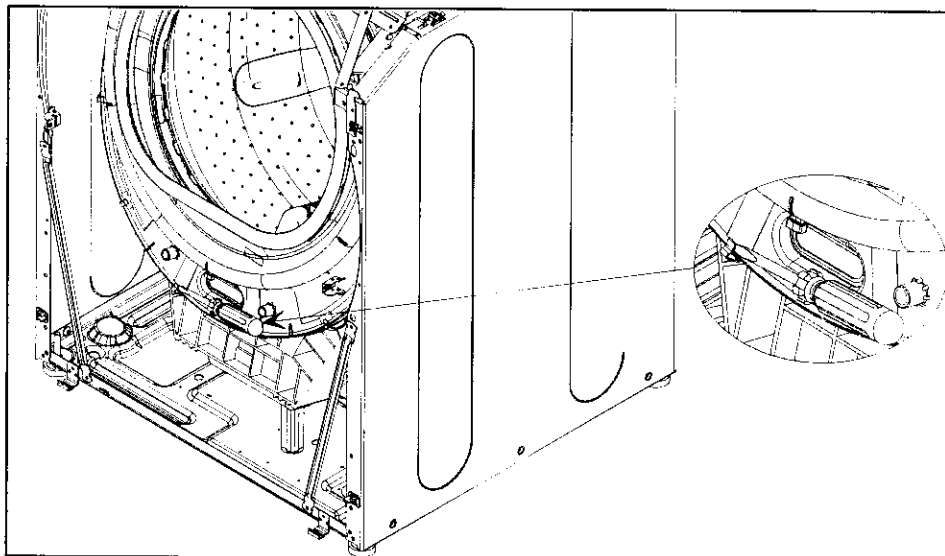

6. Remove the bolt (9/16" socket) in the center of the Drive Pulley. Slide Pulley off of Spinner Support Shaft. If necessary use Spanner Wrench to apply leverage to loosen Pulley.

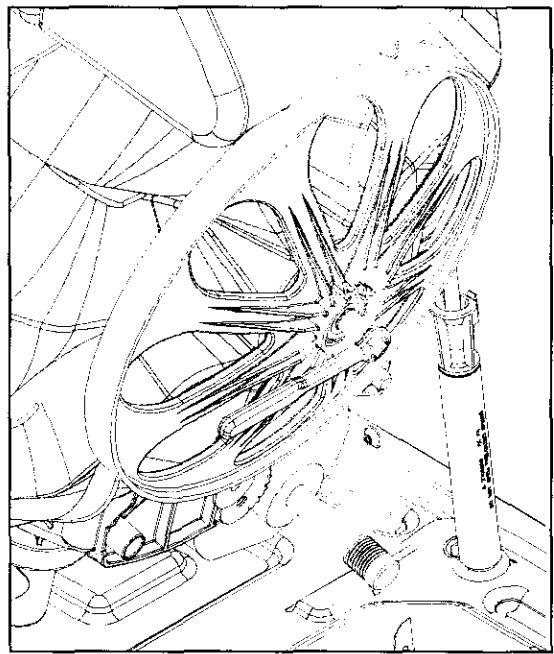
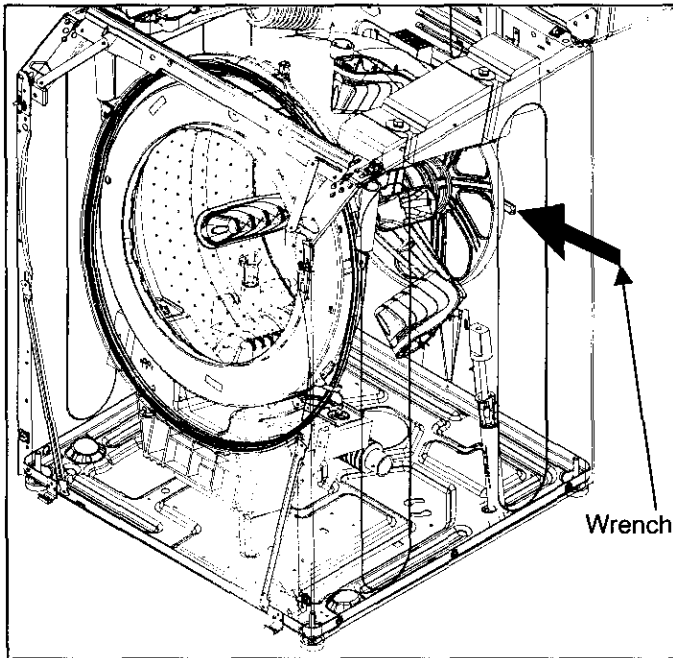

7. Remove Spin Basket by lifting out of Outer Tub.
8. Remove the rubber seal carefully from inside the Outer Tub. Remove the plastic spacer, if so equipped. Once removed, clean the surface exposed under the seal. Discard the rubber seal and plastic spacer.

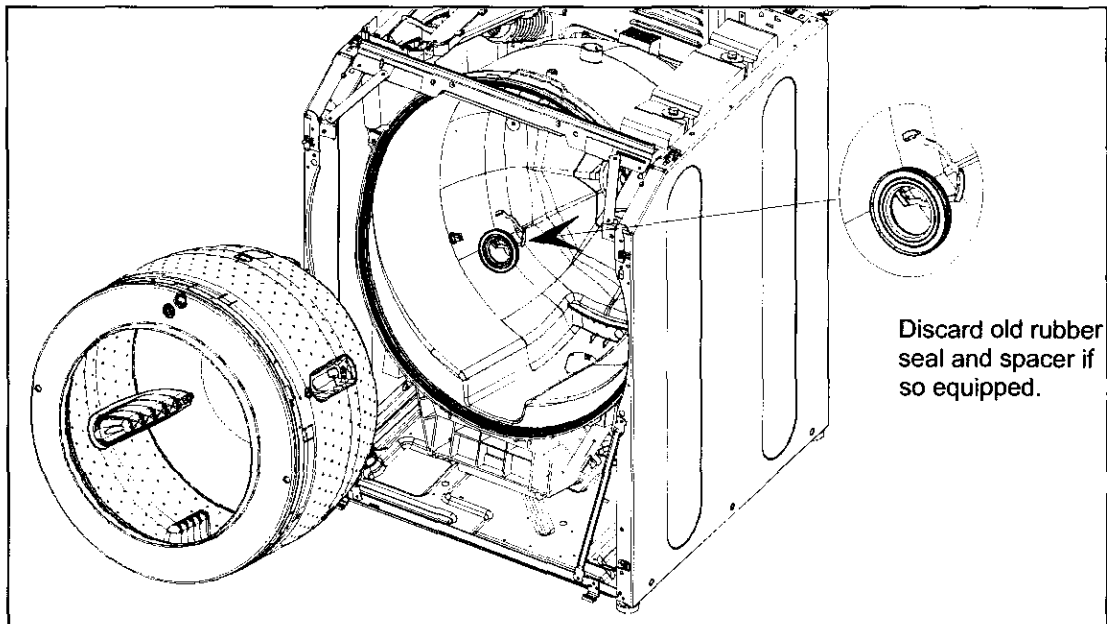

9. Using a flat blade screwdriver, carefully pry the steel washer from the Spinner Support. Remove the "O"-Ring, if so equipped. Discard the "O"-Ring and steel washer.

- Identify correct seal for replacement. Place new plastic spacer into bearing housing area (Earlier Seal Only). Place the new seal onto the insertion tool (Revised Seal). Wipe the outside diameter of the seal with a soap solution to help installation. Line the seal up to the bearing housing and press firmly into the housing until the seal is fully seated.

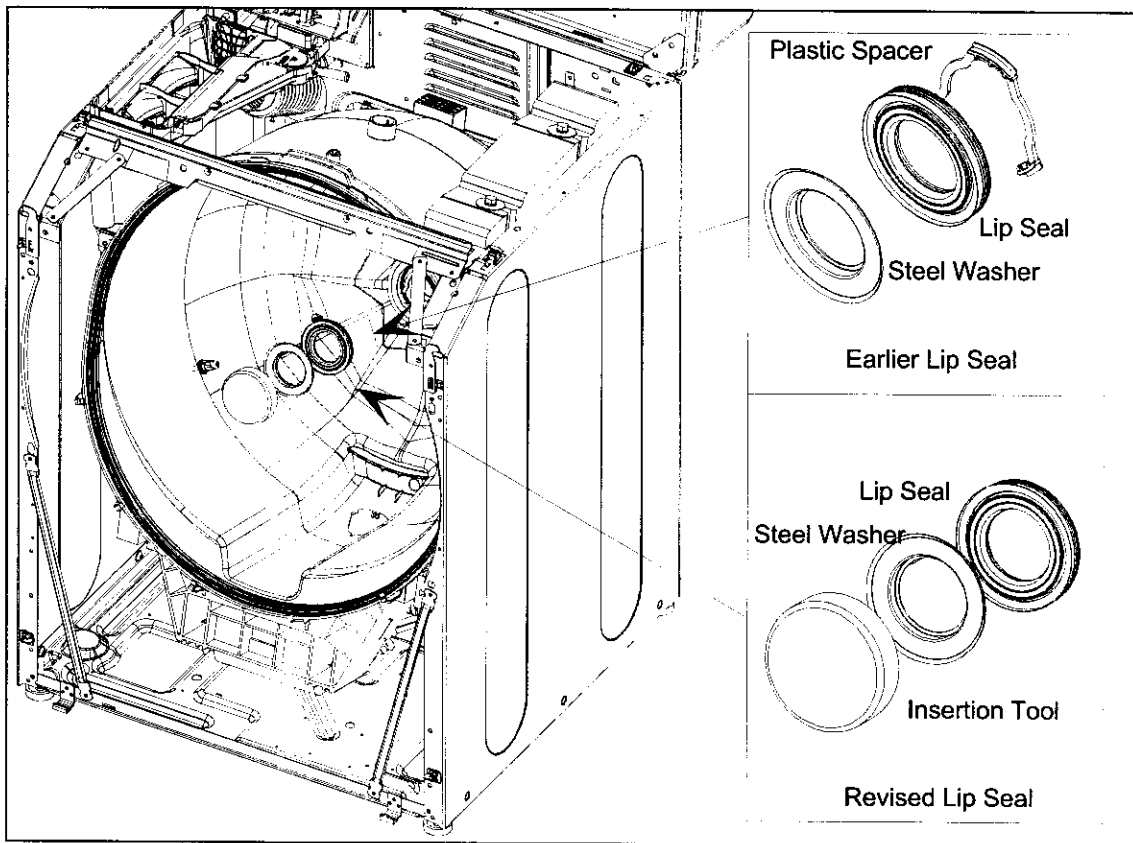

- Slide "O"-Ring (Revised Seal Only) onto the shaft and fully seat onto the base of the Spinner Support. Apply thin film of Molykote grease on spinner shaft. Spread grease thin on shaft to avoid excess from getting into next wash load. Do not use entire tube of grease.

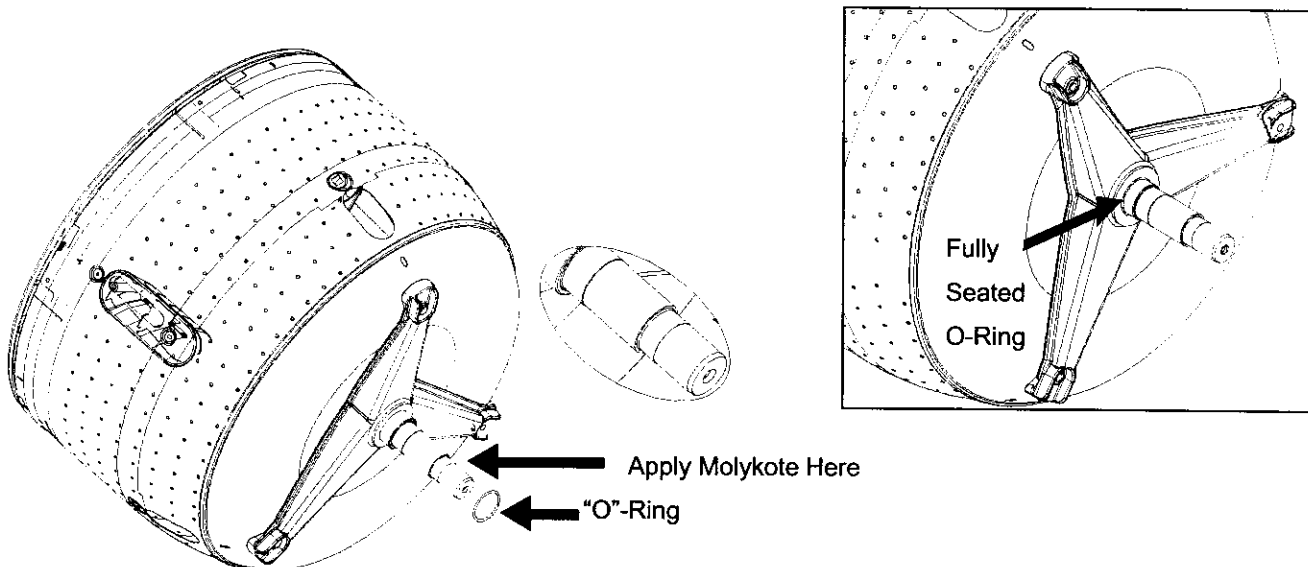

- Assemble the Spinner and Spinner Support Shaft. Position the Spinner with Spinner Support shaft into the Outer Tub.

13. Install the Drive Pulley onto the Spinner Support Shaft. Replace the tabbed pulley washer with new 1-1/4" and 1-11/16" washer along with the new retaining bolt. Tighten retaining bolt to 33 ft. lbs. Torque, drawing the shaft and seals into proper alignment.

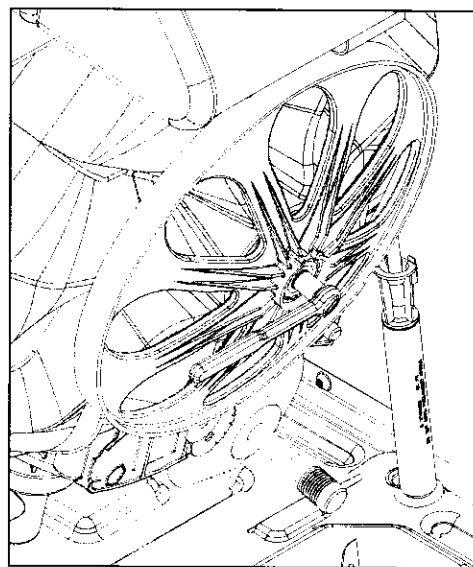
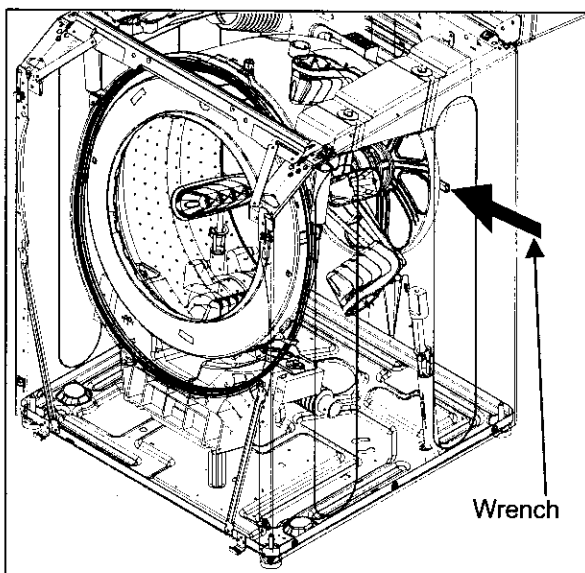
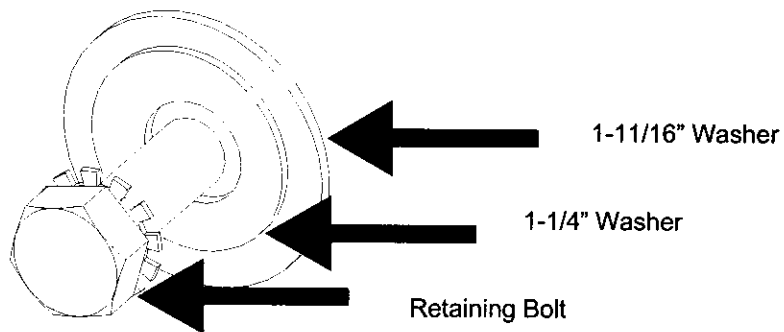

14. Run the Drive Belt over Motor Pulley and roll onto Drive Pulley.
15. Install Front Shroud Front Panel and Top Cover.
16. Test washer for proper operation. Cycle washer through a fill and drain cycle to check for leaks.