

JBL

ON AIR™

CONTROL 2.4G

OWNER'S GUIDE

THANK YOU FOR CHOOSING JBL

For more than 60 years, JBL has been involved in every aspect of music and film recording and reproduction, from live performances to the recordings you play in your home, car or office.

We're confident that the JBL system you have chosen will provide every note of enjoyment that you expected – and that when you think about purchasing additional audio equipment for your home, car or office, you will once again choose JBL.

Please take a moment to register your product on our Web site at www.jbl.com. It enables us to keep you posted on our latest advancements, and helps us to better understand our customers and build products that meet their needs and expectations.

The JBL OnAir™ Control 2.4G is an advanced wireless loudspeaker system that allows you to enjoy your favorite music in remote locations around your home or add surround speakers to your home theater system without running wires to the back of the room. To ensure trouble-free performance, please carefully read these instructions completely before connecting or using the system.

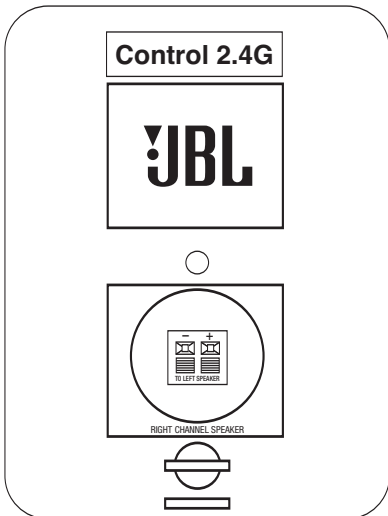
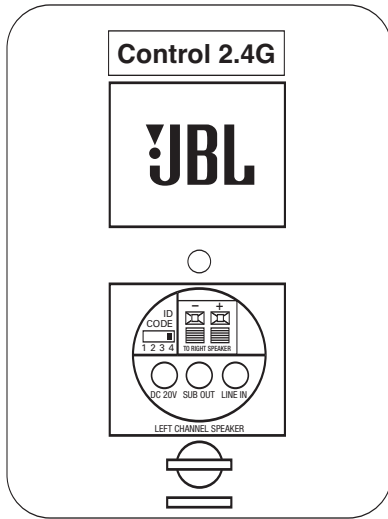
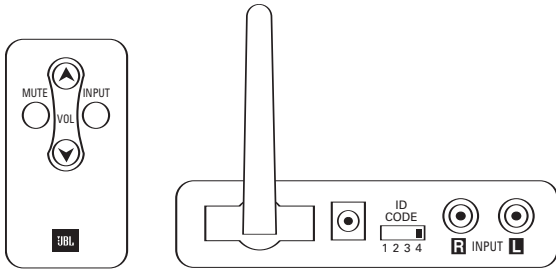

UNPACKING THE SYSTEM

Carefully unpack the system. If you suspect damage from transit, report it immediately to your dealer and/or delivery service. Keep the shipping carton and packing materials for future use. Open the package and verify the following contents:

Included

- 1 x Transmitter Module
 - 1 x Universal Power Supply for Transmitter
 - 1 x 120V 2-prong AC power cord for Transmitter Power Supply
 - 1 x 230V 2-prong AC power cord for Transmitter Power Supply
 - 1 x Wallmount bracket for Transmitter with 2 x Pan head M3x4 machine screws for attaching wallmount bracket to transmitter
 - 4 x small round self-adhesive feet – to be attached on Transmitter left side panel if Transmitter to be used vertically
- 1 x Active Speaker/Receiver (Left channel speaker)
 - 1 x Universal Power Supply for Active Speaker/Receiver
 - 1 x 120V 3-prong AC power cord for Active Speaker/Receiver Power Supply
 - 1 x 230V 3-prong AC power cord for Active Speaker/Receiver Power Supply
 - 2 x Wallmount rotatable brackets for active speaker (Includes bar wrench and back-up cords)
 - 1 x Wallmount holder for Active Speaker/Receiver Universal Power Supply
- 1 x Passive Speaker (Right channel speaker)
 - 2 x Wallmount rotatable brackets for active speaker (Includes bar wrench and back-up cords)
- 1 x Remote Control
- 1 x Interconnect cable (1m/3.3ft RCA – RCA)
- 1 x Interconnect cable (1m/3.3ft RCA – 1/8" mini plug)
- 10m/33ft. x Speaker Wire
- 1 x Owner's Manual (Multilanguage)
- 1 x USA Warranty Sheet

CONNECTIONS

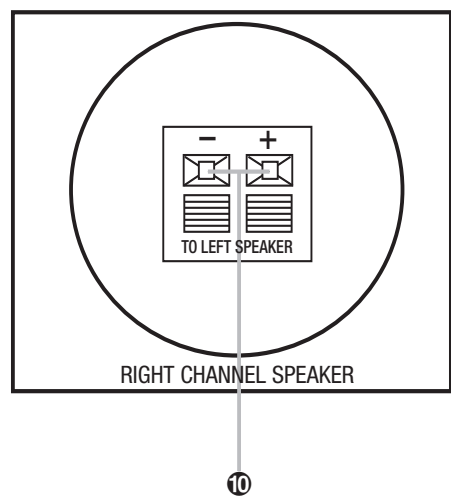
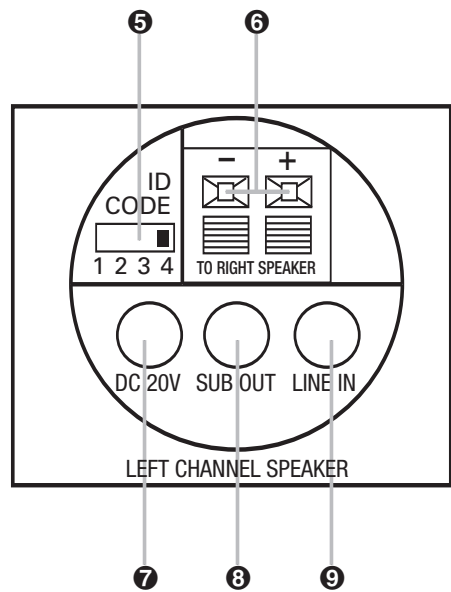
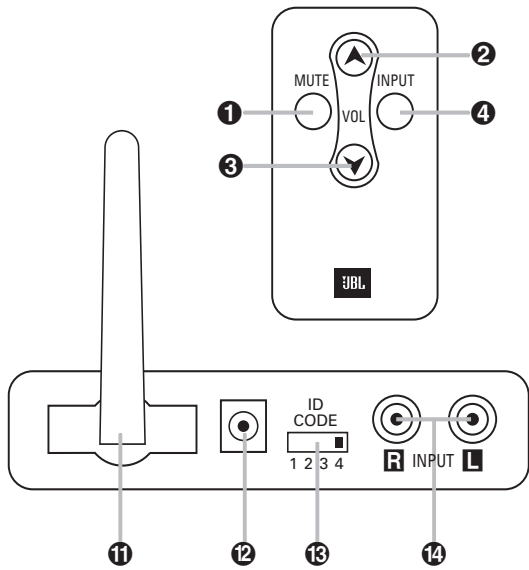

NOTES:

For the sake of simplicity, we have used the terms “receiver” and “A/V receiver” when describing the connections and operation, throughout the manual. We feel that the majority of customers purchasing this system will connect it to a receiver of some type. In the event that you are using an integrated amplifier, separate surround processor or computer sound card, the instructions would be applicable to your unit.

The JBL OnAir Control 2.4G is designed for use worldwide and includes universal power supplies for the Transmitter Module and Active Speaker. Please be sure to select and use the correct AC power cords (included) for your location. The JBL OnAir may be connected to your existing audio system in several ways. First, determine how you would like to use the JBL OnAir Control 2.4G, then follow the set-up instructions for that application.

Application 1

Adding Surround Speakers to a home theater system. Continue reading the instructions for Application 1 below.

Application 2

Adding speakers to remote locations around your home. Go directly to page xx.

Application 1

Adding Surround Speakers to a home theater system.

Determine if your receiver contains pre-amp outputs for rear-/surround-channels, usually indicated by RCA type jacks on the back of the receiver labeled as surround pre-out. (Please refer to your AV receiver’s owner’s manual to confirm whether it includes the pre-amp outputs.) If your receiver includes these outputs, follow the steps below. If not, connection is not recommended.

NOTE: Make sure power is turned off on all components.

Step 1

Connect the interconnect cable (included) to the left and right surround/rear pre-amp outputs on the back of your receiver and the input on the Transmitter Module (14) as shown in Figure 1.

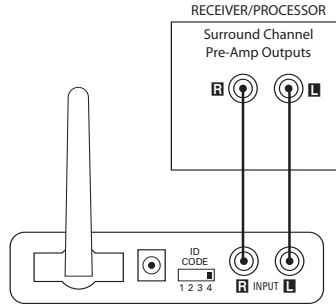

Step 2

Determine location of surround speakers.

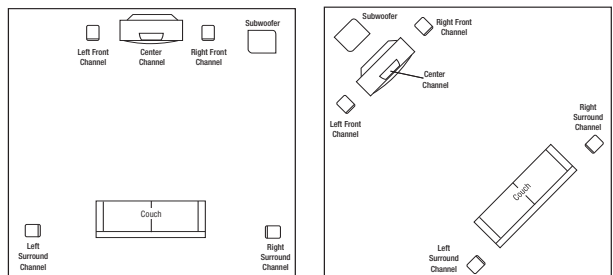

Place the active (left) speaker in the recommended location for the left surround speaker.

CONNECTIONS

Step 3

Connect the speaker wire (included) to the push terminals on the Active Speaker ⑥ and the push terminals on the rear of the Passive Speaker. See figure 4.

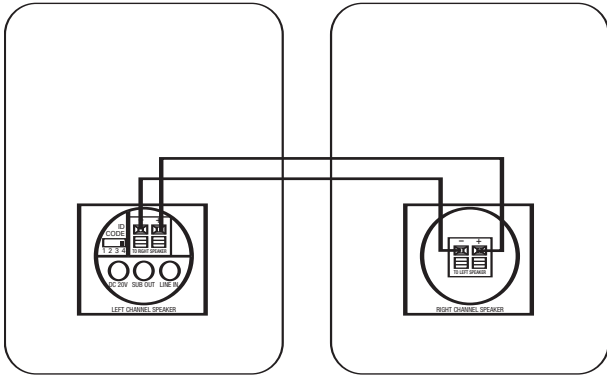

Step 4

Plug the Transmitter Module and Active Speaker into the wall outlet. Make sure the transmitter's antenna ⑪ is extended upwards.

Step 5

If necessary, configure your A/V receiver to activate the pre-amp level outputs for the surround/rear channels. (Consult your receiver's owner's manual for specific instructions.)

When connected properly, the top LED on the front of the Active Speaker should be green. The bottom LED should flash green until the Transmitter and Active Speaker "lock in". It will then illuminate solid green also.

Application 2

Adding speakers to remote locations around your home

Determine if your receiver contains pre-amp outputs for front/main channels, usually indicated by RCA type jacks on the back of the receiver labeled as pre-out. (Please refer to your receiver's owner's manual to confirm whether it includes pre-amp outputs.) If your receiver includes these outputs, follow the steps in CONNECTION OPTION A. If not, then you may hook the JBL OnAir Control 2.4G to your portable audio player or computer through their headphone jacks as described in CONNECTION OPTION B.

NOTES:

Make sure power is turned off on all components.

Some computer sound cards also contain pre-amp outputs, if you would like to connect the computer to the JBL OnAir Control 2.4G using pre-amp outputs on you computer, follow the steps in CONNECTION A.

CONNECTION OPTION A

Connecting using the pre-amp outputs on your receiver

Step 1

Connect the interconnect cable (included) to the left and right front/main pre-amp outputs or zone 2 outputs or REC Outputs and the inputs on the Transmitter Module ⑭ as shown in figure 5.

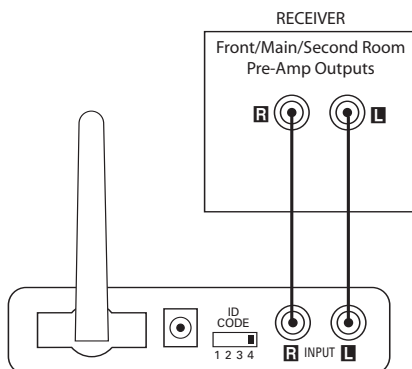

Step 2

Place the Active Speaker in the desired location in your home near an AC outlet, as it needs to plug in to the wall.

Step 3

Connect the speaker wire (included) to the push terminals on the Active Speaker ⑥ and the push terminals on the rear of the Passive Speaker ⑩ as shown in figure 4.

Step 4

Plug the Transmitter Module and Active Speaker into the wall outlet. Make sure the transmitter's antenna ⑪ is extended upwards.

Step 5

If necessary, configure your receiver to activate the pre-amp level outputs for the main/front channels. (Consult your receiver's owner's manual for specific instructions.)

When connected properly, the top LED on the front of the Active Speaker should be green. The bottom LED should flash green until the Transmitter and Active Speaker "lock in". It will then illuminate solid green also.

CONNECTION OPTION B

Connecting using the headphone jack on your portable audio player or computer

NOTES:

Make sure power is turned off on all components.

Some computer sound cards also have external speaker outputs, this connection may be used instead of the headphone jack if desired.

Step 1

Connect the RCA – 1/8" mini jack cable (included) to the headphone output of your portable audio player and the inputs on the Transmitter Module ⑭ as shown in figure 6.

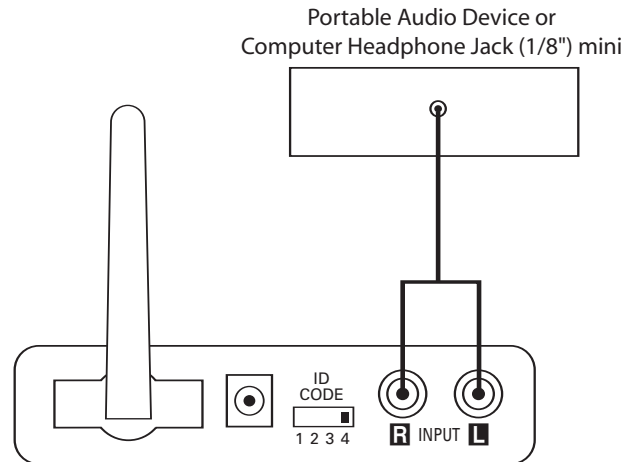

Step 2

Place the Active Speaker in the desired location in your home near an AC outlet, as it needs to plug in to the wall.

Step 3

Connect the speaker wire (included) to the push terminals on the Active Speaker ⑥ and the push terminals on the rear of the Passive Speaker as shown in figure 4.

Step 4

Plug the Transmitter Module and Active Speaker into the wall outlet. Make sure the transmitter's antenna ⑪ is extended upwards.

When connected properly, the top LED on the front of the Active Speaker should be green. The bottom LED should flash green until the Transmitter and Active Speaker "lock in". It will then illuminate solid green also.

Subwoofer Output

The JBL OnAir Control 2.4G wireless speaker system includes a subwoofer output **3** on the rear of the Active Speaker. This output allows you to feed the low-frequency sounds to a separate powered subwoofer. A powered subwoofer will deliver deeper bass response than is possible with the speakers alone.

To connect powered subwoofer to the Active Speaker, simply connect the SUB OUT **3** on the Active Speaker to the Line-In on the rear of the powered subwoofer using a 1/8" stereo mini-jack – dual-RCA cable* (Not included).

* One mini-jack – dual RCA cable is included with the system. If you are following application or connection option B above, you will need to purchase this cable.

OPERATION

Adjusting the Volume

When using the JBL OnAir Control 2.4G wireless speaker system, turn the volume level on your receiver to approximately half-way. If using with a portable audio device, turn its volume control to the maximum output. From this point on, you will use the remote control included with the JBL OnAir Control 2.4G wireless speaker system to adjust the volume.

To raise the volume, simply push up **2** on the remote control

To lower the volume, simply push down **3** on the remote control

Local Input

The JBL OnAir Control 2.4G wireless speaker system also includes a local input **9** on the rear of the Active Speaker. This input allows you to hook up a portable audio player directly to the speaker wherever you may happen to be. For example, you could have the system connected to your receiver as described in Application 2, listening to a local FM station and then hook up your portable music player to the local input and switch between the two different sources.

To connect portable audio player to the Active Speaker, simply connect the headphone jack to the Line-In **9** on the rear of the Active Speaker using a 1/8" mini-jack – 1/8" mini-jack cable (Not included).

To switch between the two sources, push the Input button (*show button or #*) on the remote control.

Indicator Light Information

	Power Indicator LED (Top)	Input LED (Bottom)
Green	System is on	Transmitter and speaker are communicating (RF lock)
Blinking Green	Receiving IR command from remote control	Transmitter and speaker are not communicating (No RF lock)
Red	Standby (no signal being received)	
Orange		Local input is selected

A Word About Wireless Products

The JBL OnAir Control 2.4G wireless speaker system utilizes an advanced wireless transceiver operating in the 2.4GHz frequency band. This is the same frequency band that is used for wireless home networks and high-quality cordless phones. It also allows for the transmission of high-performance, full-spectrum sound to remote locations, wirelessly.

Interference

In the unlikely event that you experience interference when operating the system you may change the channel in which the system operates. On the Transmitter Module and the Active Speaker, there is a four-position "ID Code" selector. Simply set the selectors to one of the other positions. The Transmitter and Active Speaker must be set to the same position in order for the system to function correctly.

Range

Like all wireless devices, the JBL OnAir Control 2.4G wireless speaker's operating range may vary depending upon variables such as building construction methods and materials, atmospheric conditions and other sources of interference. Please consult your JBL dealer or distributor or visit us at www.jbl.com for further information or assistance.

Wall and Stand Placement

Adjustable wall brackets are included for the two speakers and transmitter module. The included bracket is for wall mounting only. It is not to be used for ceiling mount.

Wall Mounting the Speakers

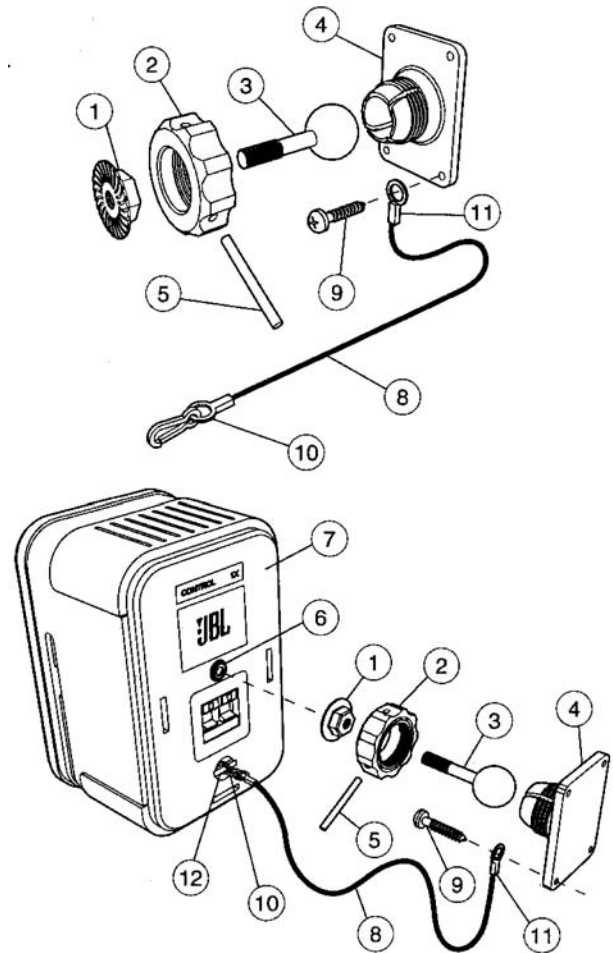

Important safety note: Proper selection of mounting hardware not included herein and proper assembly and installation of brackets, including but not limited to selection of appropriate weight bearing support and bracket use with the specified speaker only is the exclusive responsibility of the customer. Manufacturer disclaims any liability for the selection of mounting hardware and or bracket installation.

- Loosen and remove the molded nut™ by turning it counter clockwise. Use the supplied metal bar ∞ if necessary by inserting it in one of the holes on the molded nut™.
- Pull the ball/shaft £ out of the wall bracket c.
- Slide on the molded nut™ onto the ball/shaft £ with threaded opening facing the ball, and thread on the metal nut j all the way onto the ball/shaft £, with the nut j's "knurled" surface facing away from the ball.
- Screw on the ball/shaft £ into the threaded insert on the back of the speaker cabinet § until it is fully seated against the bottom of the insert.
- Tighten the "knurled" nut j using a crescent wrench until it is firmly seated against the back of the speaker and has fully locked the ball/shaft £ and the speaker cabinet together. Please note that once this nut is tightened, it may embed some marks on the back of the speaker where the attachment is made. However, these marks will be covered by the nut j.
- The back-up cord • provided as an additional measure to prevent the fall of the speaker in case the speaker becomes detached from the wall bracket. One of the two lower screws a that attach the wall bracket c to the wall, will need to go through the eyelet/ at the end of the cord before going through the wall bracket hole. Mount the wall bracket c onto a wood stud on the wall, using #10, minimum 1 inch long, pan head wood screws. Make sure that all 4 screws are driven into the stud and not in drywall. If the bracket needs to be

mounted on drywall, the use of properly selected and installed wall-anchors and screws is essential. Make sure that the screw head is at least 0.36 inches (approximately 3/8 inches) or larger in diameter so that it can properly hold the backup cord eyelet/.

- g. Holding the speaker cabinet ¶ with both hands, reinsert the ball portion of the ball/shaft £ into the wall bracket ¢.
- h. Hand tighten the molded nut ™ while positioning the speaker for the intended orientation.
- i. Once the orientation of the speaker is finalized, use the metal bar ∞ in one of the holes on the molded nut ™ and tighten securely.
- j. Securely attach the other end , of the backup cord • to the Control ONE, by engaging it through the bar ◊ on the back speaker.

Also included with the system is a wall-mount holder for the Active Speaker's power supply. If desired, you may attach this holder to the wall and insert the speaker's power supply.

Specifications

Insert Specs (Mike)

Wall Mounting the Transmitter Module

Step 1

Insert the two M3x6 machine screws through the wall bracket and into the rear of the Transmitter module as shown in figure xx.

Step 2

Attach Transmitter module with wall bracket to the wall using suitable hardware and wall anchors if necessary.

The JBL OnAir Control 2.4G wireless speakers each contain a 1/2"-20 threaded insert on the bottom (to facilitate the use of third-party floor stands) and rear (to facilitate the use of third-party wall brackets). Please consult your JBL dealers for recommendations.

NOTE: Customer is responsible for proper selection and installation of appropriate 3rd-party wall brackets and/or floor stands.

Maintenance and Service

The satellite and subwoofer enclosures may be cleaned using a soft cloth to remove fingerprints or to wipe off dust.

All wiring connections should be inspected and cleaned or remade periodically. The frequency of maintenance depends on the metals involved in the connections, atmospheric conditions and other factors, but once per year is the minimum.

In the event that your system ever needs service, contact your local JBL dealer or distributor, or visit www.jbl.com for a service center near you.

Declaration of Conformity



We, Harman Consumer Group International
2, route de Tours
72500 Château du Loir
France

declare in own responsibility that the products described in this
owner's manual are in compliance with technical standards:

EN 61000-6-3:2001
EN 61000-6-1:2001

Laurent Rault
Harman Consumer Group International
Château du Loir, France 9/06

JBL is a trademark of Harman International Industries, Incorporated, registered in the United States and/or other countries. Pro Sound Comes Home and Studio Series are trademarks of Harman International Industries, Incorporated.

Dolby and Pro Logic are registered trademarks of Dolby Laboratories.

DTS is a registered trademark of DTS, Inc.

JBL

PRO SOUND COMES HOME™

Harman Consumer Group, Inc., 250 Crossways Park Drive, Woodbury, NY 11797 USA
8500 Balboa Boulevard, Northridge, CA 91329 USA
516.255.4JBL (4525) (USA only) www.jbl.com
© 2006 Harman International Industries, Incorporated. All rights reserved.
Part No. 406-000-05529-E

H A Harman International Company

Federal Communication Commission Interference Statement

This equipment has been tested and found to comply with the limits for a Class B digital device, pursuant to Part 15 of the FCC Rules. These limits are designed to provide reasonable protection against harmful interference in a residential installation.

This equipment generates, uses and can radiate radio frequency energy and, if not installed and used in accordance with the instructions, may cause harmful interference to radio communications. However, there is no guarantee that interference will not occur in a particular installation. If this equipment does cause harmful interference to radio or television reception, which can be determined by turning the equipment off and on, the user is encouraged to try to correct the interference by one of the following measures:

- Reorient or relocate the receiving antenna.
- Increase the separation between the equipment and receiver.
- Connect the equipment into an outlet on a circuit different from that to which the receiver is connected.
- Consult the dealer or an experienced radio/TV technician for help.

FCC Caution :To assure continued compliance, any changes or modifications not expressly approved by the party responsible for compliance could void the user's authority to operate this equipment. (Example - use only shielded interface cables when connecting to computer or peripheral devices).

FCC Radiation Exposure Statement

This equipment complies with FCC RF radiation exposure limits set forth for an uncontrolled environment. This equipment should be installed and operated with a minimum distance of 20 centimeters between the radiator and your body.

This device complies with Part 15 of the FCC Rules. Operation is subject to the following two conditions:
(1) This device may not cause harmful interference, and (2) This device must accept any interference received, including interference that may cause undesired operation.