

T6HF & R601SF

2.4GHz FHSS
radio system
instruction manual



This equipment has been tested. And it found to comply with the limits for a Class B digital device pursuant to Part 15 of the FCC Rules. These limits are designed to provide reasonable protection against harmful interference in a residential installation. This equipment generates and uses and radiates radio frequency energy and, if not installed and used in accordance with the instruction, may cause harmful interference to radio communications. However, there is no guarantee that interference will not occur in a particular installation. If this equipment does cause harmful interference to radio or television reception, which can be determined by turning the equipment off and on, the user is encouraged to try to correct the interference by one or more of the following measures:

- Reorient or relocate the receiving antenna.
- Increase the separation between the equipment and receiver.
- Connect the equipment into an outlet on a circuit different from that to which the receiver is connected
- Consult the dealer or an experienced radio /TV technician for help.

Warning: A shielded-type power cord is required in order to meet FCC emission limits and also to prevent interference to the nearby radio and television reception. It is essential that only the supplied power cord be used.

1. This device complies with Part 15 of the FCC Rules. Operation is subject to the following two conditions: (1) This device may not cause harmful interference, and (2) This device must accept any interference received, including interference that may cause undesired operation.
2. Changes or modifications not expressly approved by the party responsible for compliance could void the user's authority to operate the equipment.

Name and Handling of Each Part

TRANSMITTER *T6HF* (Front Panel)

Trainer Switch

Operates the instructor transmitter when using the trainer function.

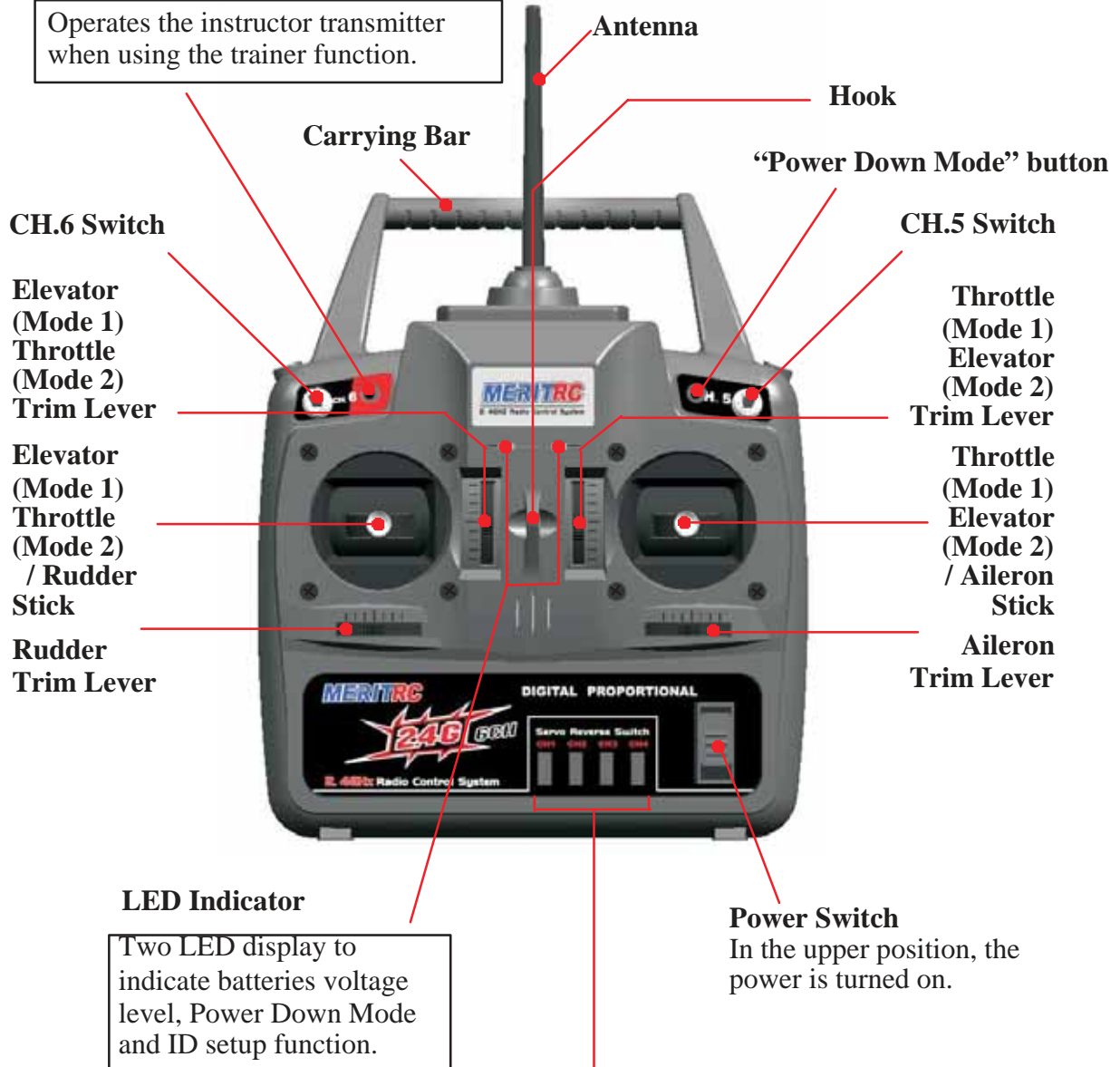

LED Indicator

Two LED display to indicate batteries voltage level, Power Down Mode and ID setup function.

Power Switch

In the upper position, the power is turned on.

Servo Reversing Switch

Switches that reverse the direction of operation of the servos. The lower position is the normal side and the upper position is the reverse side.

Channel display

AIL. : Aileron (CH1)
 ELE. : Elevator (CH2)
 THR. : Throttle (CH3)
 RUD. : Rudder (Ch4)

Operating direction display

REV. : Reverse side
 NOR.: Normal side

TRANSMITTER T6HF (Rear and Side Panel)



Trainer jack

Connects the trainer cord when using the trainer function.
(The trainer cord is sold separately.)

Charging jack



Battery cover

Use when replacing the battery .
Slide the cover downward while pressing the part marked "  ".

RECEIVER

R601SF

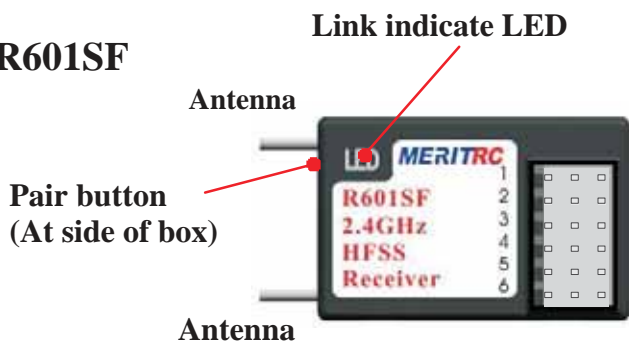

Channel Output

"1": Aileron servo (CH1)
 "2": Elevator servo (CH2)
 "3": Throttle servo (CH3)
 "4": Rudder servo (CH4)
 "5": (Not used) (Ch5)
 "6": (Not used) (CH6)

Special note for 2.4GHz FHSS radio system setup

Since the 2.4GHz have different characteristics than that of the conventional frequencies, please read this section carefully to enjoy safe flight with the 2.4GHz system.

Receiver's Antenna installation

The R601FS has two antennas. These antennas have a diversity function to decrease the chance of a receiving error.

The wavelength of the 2.4GHz is much shorter than that of the conventional frequencies, it is very susceptible to loss of signal which results in a receiving error. In order to avoid this phenomenon, the R601FS adopted a diversity antenna system.

To obtain the best results of the diversity function, please refer to the following instructions;

1. The two antennas must be kept as straight as possible. Otherwise it will reduce the effective range.
2. The two antennas should be placed at 90 degrees to each other. This is not a critical figure, but the most important thing is to keep the antennas away from each other as much as possible. Larger models can have large metal objects that can attenuate the RF signal. In this case the antennas should be placed at both sides of the model. Then the best RF signal condition is obtained at any flying attitude.
3. The antennas must be kept away from conductive materials, such as metal and carbon by at least a half inch. The coaxial part of the antennas does not need to follow these guidelines, but do not bend it in a small radius.
4. Keep the antennas away from the motor, ESC, and other noise sources as much as possible.

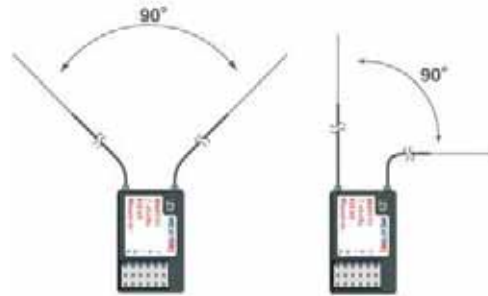

- * The two antennas should be placed at 90 degrees to each other.
- * The main purpose of the photo demonstrates how the antenna should be placed. For actual installation the receiver must be wrapped with a sponge or placed with floating material to protect it from vibration.

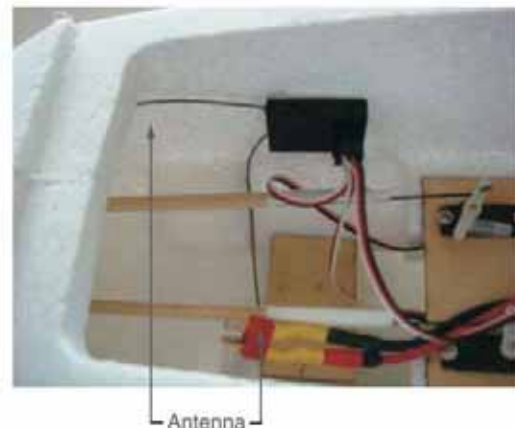

The receiver contains precision electronic parts. It is the most delicate radio component on-board the model and should be protected from vibration, shock and temperature extremes. To protect the receiver, wrap it in R/C foam rubber or other vibration-absorbing material. If appropriate, waterproof the receiver by placing it in a plastic bag and closing the open end with a rubber band before wrapping it in foam. If moisture enters the receiver, intermittent operation or a failure may result. Wrapping the receiver in a plastic bag also protects it from fuel and exhaust residue which, in some models, can work its way into the fuselage.

Transmitter antenna

1. The transmitter antenna is adjustable so please make sure that the antenna is never pointed directly at the model when flying as this creates a weak signal for the receiver.
2. Keep the antenna perpendicular to the transmitter's face to create a better RF condition for the receiver. Of course this depends on how you hold the transmitter, but in most cases, adjusting the transmitter antenna so that it is perpendicular to the face will give the best results. Please adjust the transmitter antenna to the way you hold the transmitter.
3. NEVER grip the antenna when flying as this degrades RF quality.



Pair Procedure

The transmitter has a individual randomize ID that is created in the factory, In order to start operation, the receiver must be linked with the ID code of the transmitter with which it is being paired. Once the link is made, the ID code is stored in the receiver and no further linking is necessary unless the receiver is to be used with another transmitter. When you purchased another R601FS, this procedure is necessary; otherwise the receiver will not work.

1. Place the transmitter and the receiver close to each other within 1 meter.
2. Turn on the transmitter then the receiver. If they are not paired, the receiver red LED will blink per second or off, follow the next steps to link and pair the receiver and the transmitter:
3. Press down the receiver "pair button" switch for more than two seconds, once the receiver LED start to blink quickly, it shows they are paired, release the switch.

4. When the linking is complete, the receiver LED will change to solid red and receiver will start to respond to the transmitter after 2 seconds. Please refer to the table below for the LED status of the receiver's condition.

Receiving signals and ID is matched. : On
Receiving signals, but ID is matched. : Off
No signal reception. : Off
Receiver ID memory is empty. : Blink per second

Change the transmitter ID

The transmitter has a individual randomize ID that is created in the factory, Even it is almost have no chance to meet the same ID transmitter in the same fly field, in case it does happen. The transmitter has an ID set up function.

By holding the "PDM" button to turn on the transmitter, the two LED will blink. Press the "PDM" button to random change a new ID, the new ID will active when the transmitter turn on next time, Once you have set up a new ID for your transmitter, please must remember to re-Link your receiver with your transmitter before flight.

You can go back to the original factory set ID by holding the "PDM" when turn on the transmitter, without press the "PDM" button, turn it off and on again to get back the original ID.

Range check the radio

A range check must be performed before the first flight of a new model. It is not necessary to do a range check before every flight (but is not a bad idea to perform a range check before the first flight of each day). A range check is the final opportunity to reveal any radio malfunctions, and to be certain the system has adequate operational range.

1. There is "Power Down Mode" build in for doing a ground range check
To activate the "Power Down Mode" by pressing the "PDM" button on the right upper panel of the transmitter. The Green LED will turn off to indicate the PDM is working. During this mode, the RF power is reduced so the range test can be performed.
2. Walk away from the model while simultaneously operating the controls. Have an assistant stand by the model and signal what the controls are doing to confirm that they operate correctly. You should be able to walk 30 - 50 paces approximately from the model without losing control.
3. If everything operates correctly, return to the model. The "Power Down Mode" continues for 60 seconds and after that the power will go back to the normal level. To exit the "Power Down Mode" before the 60 seconds, press the "PDM" key again.
4. NEVER start flying when the "Power Down Mode" is active.

Transmitter Operation and Movement of Each Servo

Before making any adjustments, learn the operation of the transmitter and the movement of each servo. (In the following descriptions, the transmitter is assumed to be in the standby state.)

AILERON OPERATION

When the aileron stick is moved to the right, the right aileron is raised and the left aileron is lowered, relative to the direction of flight, and the plane turns to the right. When the aileron stick is moved to the left, the ailerons move in the opposite direction. To level the plane, the aileron stick must be moved in the opposite direction. When the aileron stick is tilted and held, the plane will roll.

Aileron(ch1)

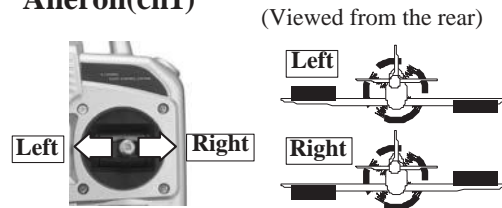

ELEVATOR OPERATION

When the elevator stick is pulled back, the tail elevator is raised and the tail of the plane is forced down, the air flow applied to the wings is changed, the lifting force is increased, and the plane climbs (UP operation). When the elevator stick is pushed forward, the elevator is lowered, the tail of the plane is forced up, the air flow applied to the wings is changed, the lifting force is decreased, and the plane dives (DOWN operation).

Elevator(ch2)

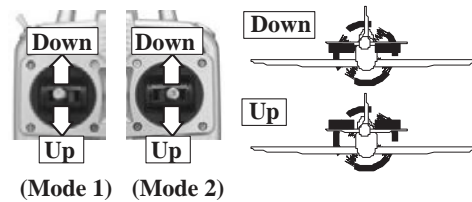

THROTTLE OPERATION

When the throttle stick is pulled back, the engine throttle lever arm moves to the SLOW (low speed) side. When the throttle stick is pushed forward, the throttle lever arm moves to the HIGH (high speed) side.

Throttle(ch3)

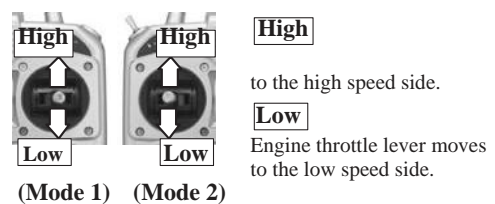

RUDDER OPERATION

When the rudder stick is moved to the right, the rudder moves to the right and the nose points to the right, relative to the direction of flight. When the rudder stick is moved to the left, the rudder moves to the left and the nose points to the left and the direction of travel of the plane changes.

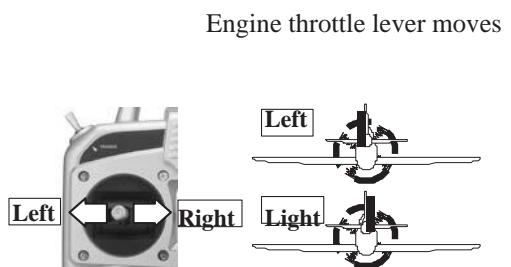

ADJUSTMENT AND INSTALLATION

This section describes the installation method and adjustment method after installation when installing the receiver, servos, etc. to the plane.

Connections

Connection example is shown below.

Connection Example

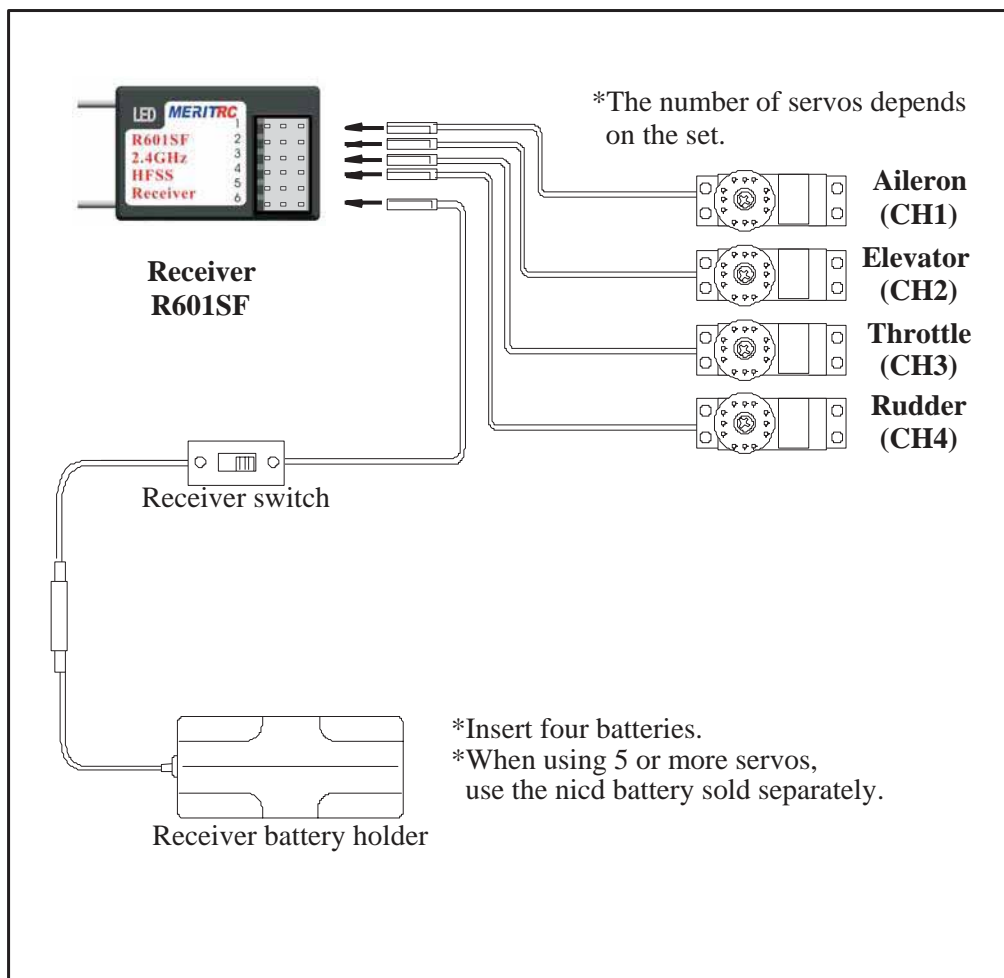

⚠ WARNING

Connector Connection

- ❗ Insert the receiver, servo, and battery connectors fully and firmly.

If vibration, etc. causes a connector to work loose during flight, the plane may crash.

Receiver Vibrationproofing / Waterproofing

- ❗ Vibrationproof the receiver by wrapping it in sponge rubber or some such material. If the receiver may get wet, waterproof it by placing it in a plastic bag.

If the receiver is subjected to strong vibration and shock, or gets wet, it may operate erroneously and cause a crash.

Receiver Antenna

- ⊘ Do not cut or bundle the receiver antenna. Also, do not bundle the antenna together with the servo lead wires.

Cutting or bundling the receiver antenna will lower the receiver sensitivity and shorten the flight range and cause a crash.

<Antenna installation>

For aircraft, attach the antenna to the top of the tail.

Attach the antenna with a rubber band, etc.

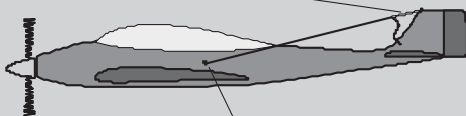

Use a rubber grommet, etc. at the part at which the antenna comes out of the fuselage so that it will not break. Also tie a knot in the antenna wire inside the fuselage so that the antenna cannot be pulled out.

Servo Throw

- ❗ Operate each servo horn over its full stroke and adjust so that the pushrod does not bind or is not too loose.

Unreasonable force applied to the servo horn will adversely affect the servo and drain the battery quickly.

Servo Installation

- ❗ Install the servos to the servo mount, etc. through a rubber grommet. Also install the servos so that the servo case does not directly touch the servo mount or other parts of the fuselage.

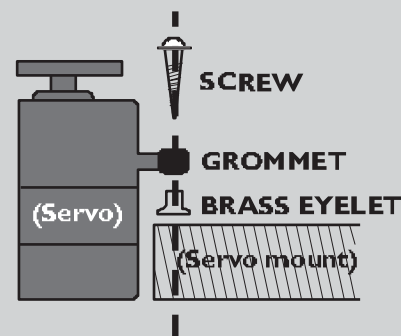

Power Switch Installation

When installing a receiver power switch to the fuselage, cut a rectangular hole somewhat larger than the full stroke of the switch knob and install the switch so it moves smoothly from ON to OFF.

Also install the switch where it will not come into direct contact with engine oil, dust, etc. Generally, install the switch to the fuselage at the side opposite the muffler exhaust.

Adjustments

The operating direction, neutral position, and steering angle of each servo are adjusted.

⚠ CAUTION

!

Adjustment Procedure

Before making any adjustments, set all the SERVO REVERSE switches on the front of the transmitter to the lower (NOR) position. (Switch the switches with a small screwdriver, etc.)

Turn on the transmitter and receiver power switches and make the following adjustments:

1 Check the direction of operation of each servo.

If a servo operates in the wrong direction, switch its SERVO REVERSE switch. (The direction of operation can be changed without changing the linkage.)

*Note that the direction of the aileron servo is easily mistaken. (Page 10)



2 Check the aileron, elevator, and rudder neutral adjustment and left-right (up-down) throw.

Check that when trimmed to the center, the servo horn is perpendicular to the servo and check the neutral position of the fuselage control surfaces (aileron, elevator, rudder,

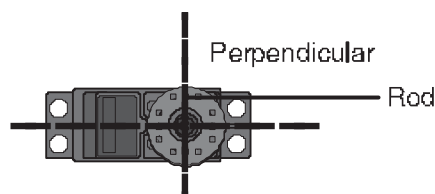

etc.). If the neutral position has changed, reset it by adjusting the length of the rod with the linkage rod adjuster.

When the throw is unsuitable (different from steering angle specified by the kit instruction manual), adjust it by changing the servo horn and each control surface horn rod .

3 Check the engine throttle (speed adjustment) linkage.

Change the servo horn installation position and hole position so that the throttle is opened fully when the throttle stick is set to HIGH (forward) and is closed fully when the throttle stick and throttle trim are set for maximum slow (backward position and lower position, respectively).

4 After all the linkages have been connected, recheck the operating direction, throw, etc.

*Before flight, adjust the aircraft in accordance with the kit and engine instruction manuals.

5 Fly the plane and trim each servo.