



# Adventure Kids Walkie Talkies

Ages 3+

Item no.: 613241

ADULT BATTERY INSTALLATION REQUIRED

## INTRODUCTION

Adventures await you and a friend! With your Little Tikes™ Adventure Kids Walkie Talkies, you don't even have to be near to talk to each other. Have a fun time pretending to be secret agents, emergency personnel, or just sharing secrets!

## CONTENTS

- 1 Little Tikes™ Adventure Kids Walkie Talkies

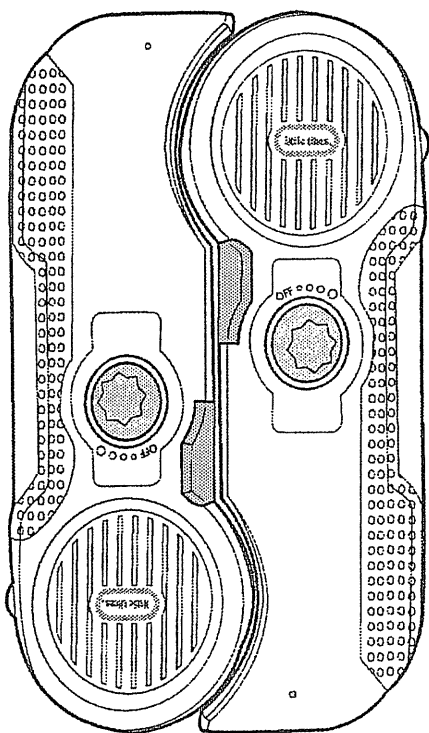

Units lock together for easy handling

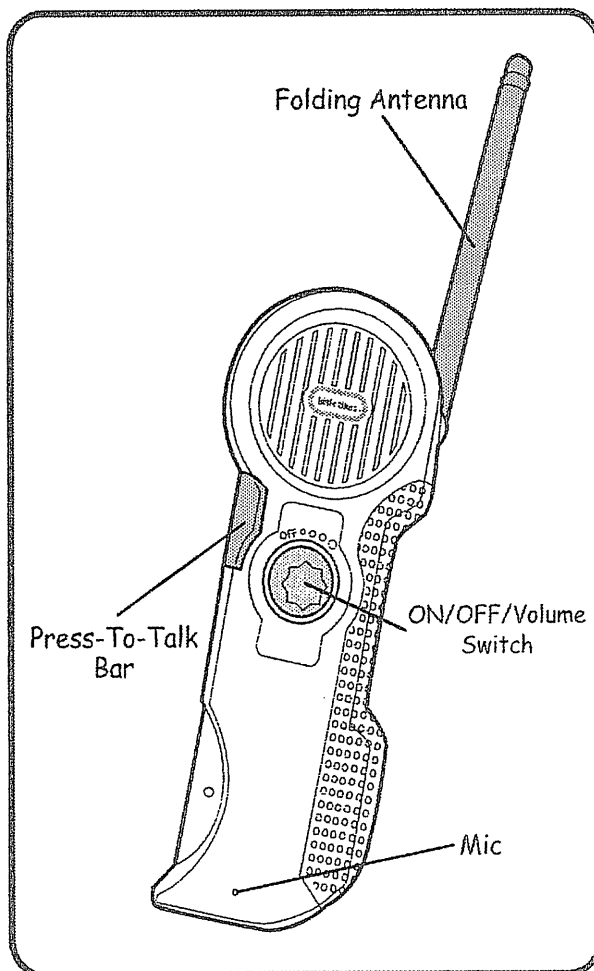

Illustrations may vary from actual contents.

## BEFORE YOU BEGIN

Prior to playing an adult must install batteries (not included). Here's how:

1. Switch the ON/OFF switch to the OFF position.
2. Using a Phillips screwdriver (not included) remove the screws and battery compartment covers from the back of the Walkie Talkies. (Fig. 1)
3. Install one (1) 9V alkaline battery in each unit making sure the (+) and (-) ends face the proper direction as indicated inside the battery compartment. (Fig. 2)
4. Replace the compartment covers and tighten the screws.

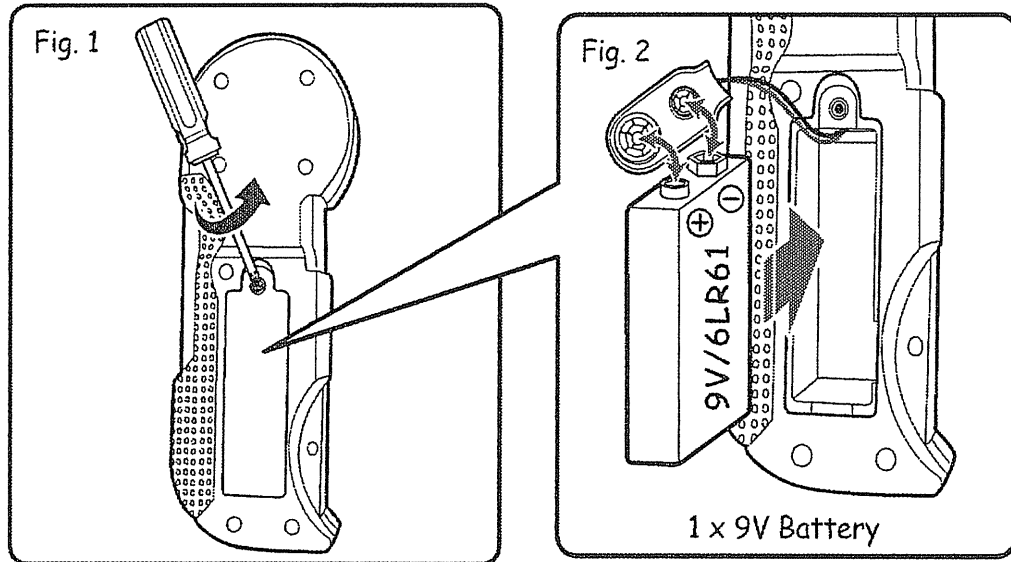

## SNAP-FIT LOCKING DESIGN

Your Walkie Talkies have a special Snap-Fit Locking Design to keep the set together for ease of handling and travel.

1. To separate the Walkie Talkies, grasp them by the handles and pull apart.
2. To lock the Walkie Talkies together fit the blade of one Walkie Talkie into the groove in the other and press them together firmly until they click into place.

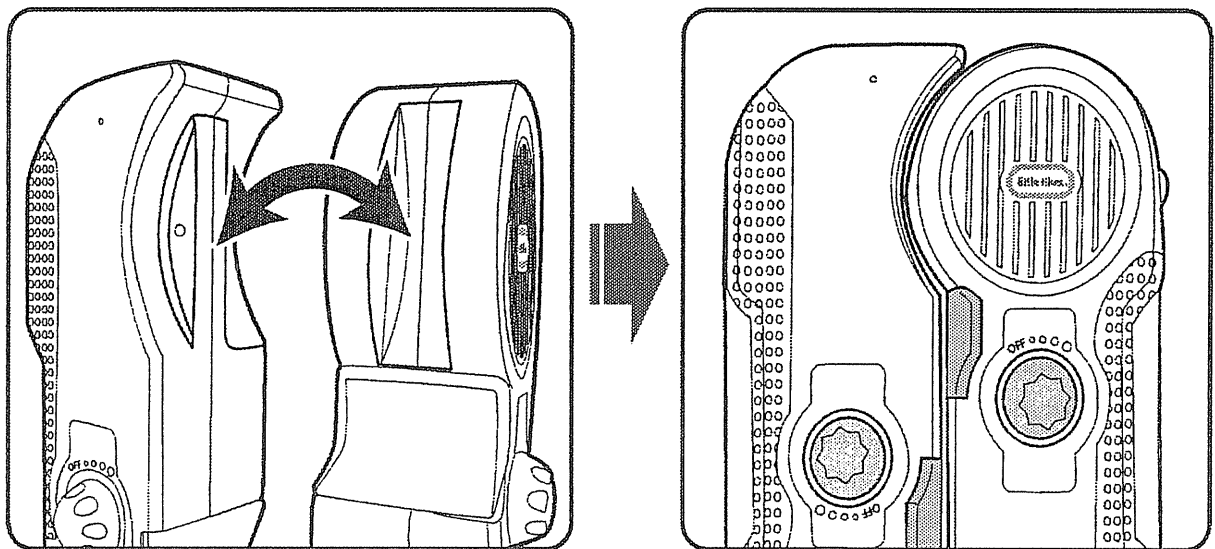

## QUICK START

You and your friend will be the coolest with your Little Tikes™ Adventure Kids Walkie Talkies.

1. Unfold the antenna by lifting it out of the antenna groove and flipping it upward. (Fig. 3)
2. Turn the ON/OFF/Volume Switch just enough to turn the Walkie Talkies on. (Fig. 3)
3. As you speak and listen, slowly adjust the Volume to a comfortable level.
4. Press and hold the Press-to-Talk Bar to talk to your friend. (Fig. 4)
5. Release the Press-to-Talk Bar to hear your friend talk to you. (Fig. 5)

NOTE: When transmitting, speak clearly in a normal voice and talk directly into the microphone.

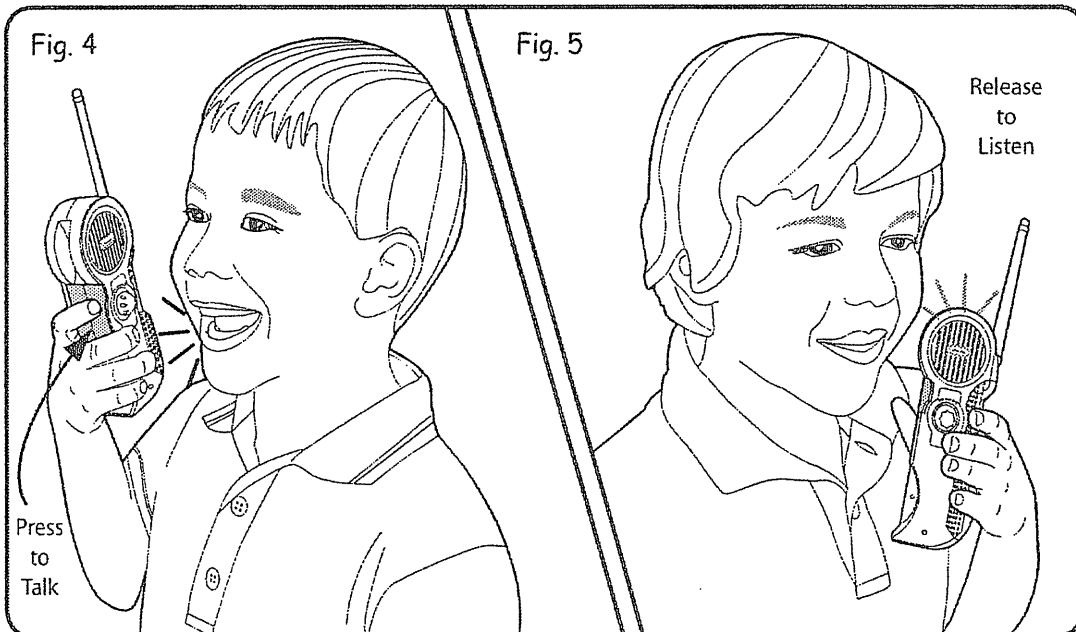
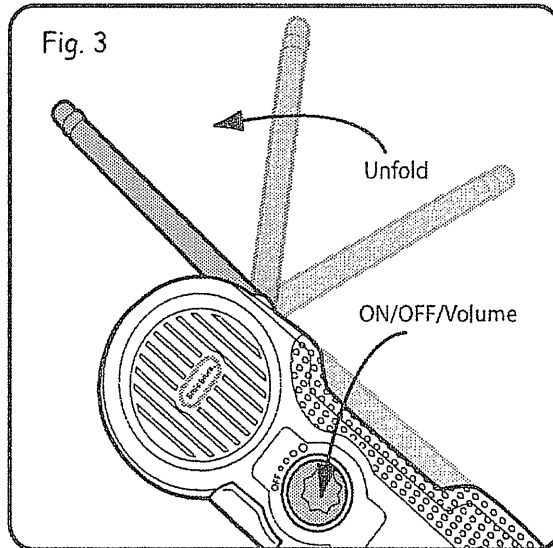

## TROUBLESHOOTING

- For best reception use Walkie Talkies in an area away from buildings or other obstacles.
- If reception becomes weak install fresh alkaline batteries.
- All Walkie Talkies are subject to electronic interference, stay away from or turn off nearby electronic devices such as cordless phones, baby monitors, intercoms or any other "broadcast" devices.
- Your Walkie Talkies have been fully adjusted prior to shipment from the factory. DO NOT touch any internal parts when replacing the battery.
- After use, always turn ON/OFF switch to the OFF position to save battery power.
- Keep your Walkie Talkies in a clean, dry place.
- DO NOT expose your Walkie Talkies to water or moisture of any kind.

## SAFE BATTERY USAGE

- Use alkaline batteries for best performance and longer life.
- Use only the type battery recommended for the unit.
- Batteries should be replaced only by an adult.
- Insert batteries with the correct polarity (+ and -).
- Do not mix old and new batteries.
- Do not mix alkaline, standard (carbon-zinc), or rechargeable (nickel-cadmium) batteries.
- Do not short-circuit batteries.
- When not used for an extended time, remove batteries to prevent possible leakage and damage to the unit.
- Do not mix rechargeable and non-rechargeable batteries.
- Rechargeable batteries are to be removed from the toy before charging.
- Rechargeable batteries are to be recharged only under adult supervision.
- Do not recharge non-rechargeable batteries.
- Exhausted batteries are to be removed from the toy.
- Do not dispose of batteries in fire as they may leak or explode.

NOTE: The voltage of a fully-charged, rechargeable battery is often lower than that of a fresh alkaline battery. Therefore, it is recommended that alkaline batteries be used instead of rechargeable batteries for best performance and for longest play time.

## FCC COMPLIANCE

NOTE: This equipment has been tested and found to comply with the limits for Class B digital device, pursuant to Part 15 of FCC Rules. These limits are designed to provide reasonable protection against harmful interference in a residential installation. This equipment generates, uses and can radiate radio frequency energy and, if not installed and used in accordance with the instructions, may cause harmful interference to radio communications. However, there is no guarantee that interference will not occur in a particular installation. If this equipment does cause harmful interference to radio or television reception, which can be determined by turning the equipment off and on, the user is encouraged to try to correct the interference by one or more of the following measures:

- Reorient or relocate the receiving antenna.
- Increase the separation between the equipment and receiver.
- Connect the equipment into an outlet on a circuit different from that to which the receiver is connected.
- Consult the dealer or an experienced radio/TV technician for help.

This device complies with Part 15 of the FCC Rules. Operation is subject to the following two conditions: (1) This device may not cause harmful interference, and (2) this device must accept any interference received, including interference that may cause undesired operation.

Warning: Changes or modifications to this unit not expressly approved by the party responsible for compliance could void the user's authority to operate the equipment.



Let's care for the environment!

The wheelie bin symbol indicates that the product must not be disposed of with other household waste. Please use designated collection points or recycling facilities when disposing of the item.

Do not treat old batteries as household waste. Take them to a designated recycling facility.

Please keep this manual as it contains important information.



0908-0-E

TM & © The Little Tikes Company,  
an MGA Entertainment company.  
LITTLE TIKES™ and all related logos, names, characters,  
distinctive likenesses and slogans, as well as the packaging  
and images appearing thereon, are the exclusive property of  
The Little Tikes Company.  
Little Tikes Consumer Services  
2180 Barlow Road  
Hudson, Ohio 44236 USA  
(800) 321-0183  
Printed in China



[www.littletikes.com](http://www.littletikes.com)