

 MITSUBISHI

**HS-U270**

Video  
Cassette  
Recorder  
Owner's  
Guide

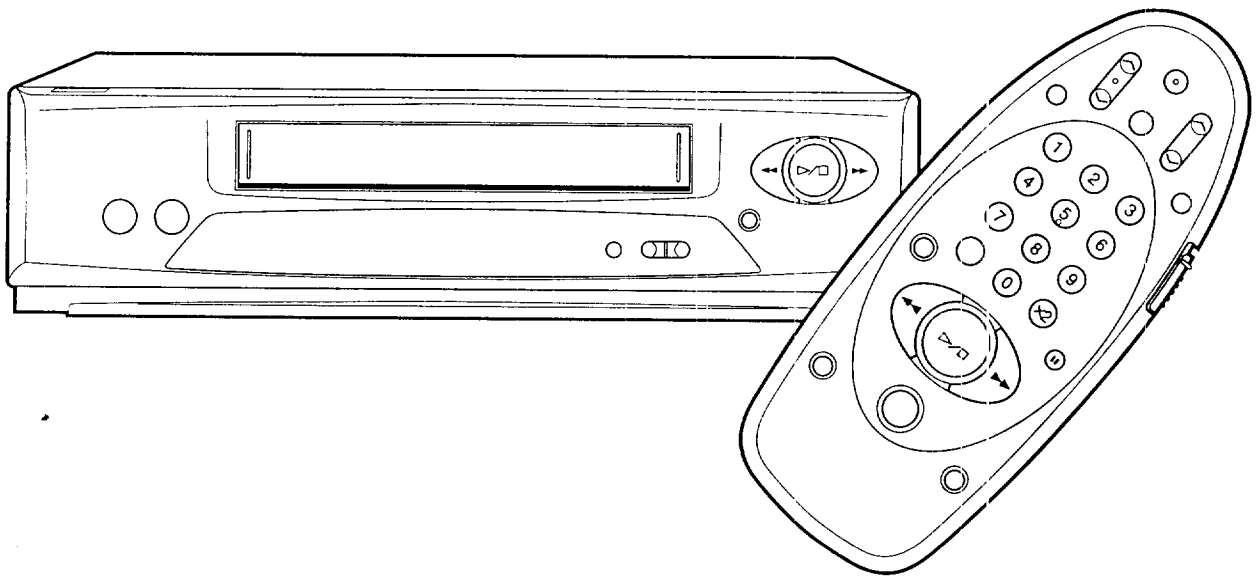



**VCR Plus+<sup>C3</sup>**  
w/Cable Channel  
Changer

VCR Plus+ and PlusCode are trademarks of Gemstar Development Corporation. The VCR Plus+ system is manufactured under license from Gemstar Development Corporation.

With VCR Plus+C<sup>3</sup> system, this video cassette recorder can automatically select the appropriate channel on your compatible cable box or satellite receiver. C<sup>3</sup> and VCR Plus+C<sup>3</sup> are trademarks of Gemstar Development Corporation.

**VHS**

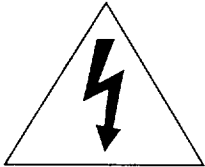
This Video Cassette Recorder is based on the VHS format. Only video cassette tapes with the **VHS** mark may be used with this model.

	<b>CAUTION</b> RISK OF ELECTRIC SHOCK DO NOT OPEN	
<p><b>CAUTION:</b> TO REDUCE THE RISK OF ELECTRIC SHOCK, DO NOT REMOVE COVER (OR BACK). NO USER-SERVICEABLE PARTS INSIDE. REFER SERVICING TO QUALIFIED SERVICE PERSONNEL..</p>		

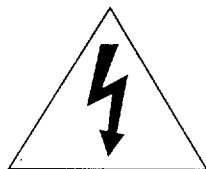

The lightning flash with arrowhead symbol, within an equilateral triangle, is intended to alert the user to the presence of uninsulated "dangerous voltage" within the product's enclosure that may be of sufficient magnitude to constitute a risk of electric shock to persons.



The exclamation point within an equilateral triangle is intended to alert the user to the presence of important operating and maintenance (servicing) instructions in the literature accompanying the product.

**IMPORTANT:**

RECORDING OF COPYRIGHTED TELEVISION PROGRAMS MAY VIOLATE COPYRIGHT LAW.

**WARNING:**

TO REDUCE THE RISK OF FIRE OR ELECTRIC SHOCK, DO NOT EXPOSE THIS PRODUCT TO RAIN OR MOISTURE.

**CAUTION:**

TO PREVENT ELECTRIC SHOCK HAZARD, DO NOT USE THIS (POLARIZED) PLUG WITH AN EXTENSION CORD, RECEPTACLE OR OTHER OUTLET UNLESS THE BLADES CAN BE FULLY INSERTED TO PREVENT BLADE EXPOSURE.

**NOTE TO CATV SYSTEM INSTALLER:**

THIS REMINDER IS PROVIDED TO CALL THE CATV SYSTEM INSTALLER'S ATTENTION TO SECTION 820-40 OF THE NEC WHICH PROVIDES GUIDELINES FOR PROPER GROUNDING AND, IN PARTICULAR, SPECIFIES THAT THE CABLE GROUND SHALL BE CONNECTED TO THE GROUNDING SYSTEM OF THE BUILDING, AS CLOSE TO THE POINT OF CABLE ENTRY AS PRACTICAL.



# Table of Contents

<b>Important Safeguards .....</b>	<b>2</b>	<b>Programming the VCR to Receive TV</b>	
<b>Preface</b>		Channels .....	29
<b>Welcome to Mitsubishi .....</b>	<b>5</b>	Programming channels automatically ..	29
Unpacking Your VCR .....	5	Using video mute .....	32
<b>Chapter One</b>		Adding and deleting channels .....	32
<b>Getting to Know Your VCR .....</b>	<b>6</b>	Selecting a channel .....	33
Front Panel Buttons and Functions .....	6	Using the Audio and Video Functions .....	34
Fluorescent Display .....	7	Descriptions of audio and video	
Overview of the Remote Control .....	8	functions .....	34
Rear Panel Terminals .....	10	Selecting and adjusting the audio and	
<b>Chapter Two</b>		video functions .....	35
<b>Connecting Your VCR .....</b>	<b>11</b>	Setting the VCR Plus+ Guide Channel	
Connecting the Antenna or Cable		Numbers .....	36
to the VCR .....	11	Recording .....	38
Connecting cable antennas .....	11	Recording a current broadcast .....	39
Connecting other antennas .....	12	Programming your VCR to record .....	39
Connecting separate UHF/VHF		Cancelling a recording in progress .....	42
antennas .....	13	Programming with the VCR Plus+ system	42
Connecting the Television .....	14	Using One-Touch Recording (OTR) .....	43
Determining if you need a splitter .....	14	Using One Key Programming .....	45
Connecting an older TV without audio and		Using Quick Program .....	47
video inputs to the VCR .....	15	Notes about programmed recording .....	47
Connecting a modern TV with audio and		<b>Chapter Four</b>	
video inputs .....	16	<b>Using the Advanced Features .....</b>	<b>51</b>
Connecting a DSS® or PRIMESTAR®		Using the Advanced Playback Controls .....	51
Receiver (optional) .....	16	Using special effects .....	51
Connecting the A/V Network (optional) .....	18	Adjusting the tracking .....	52
<b>Chapter Three</b>		Using the time counter .....	53
<b>Operating Your VCR .....</b>	<b>19</b>	Displaying the Remaining Time and the	
Setting Up Your VCR for the First Time ..	19	Present Time .....	53
Setting up your VCR if you are using a TV		Displaying the time gauge and the	
without Audio and Video Inputs (Older		remaining time .....	53
TV) .....	19	Displaying the present time .....	54
Setting up your VCR if you are using a TV		Searching Techniques .....	54
equipped with Audio and Video Inputs		Quick searching .....	54
(Modern TV) .....	20	Speed searching .....	55
Using the Remote Control .....	20	Using counter zero stop .....	55
Using the remote control to operate		Index search techniques .....	56
the VCR .....	20	Using the Advanced Options .....	56
Using the remote control to operate		Using the auto daylight saving time .....	57
the TV .....	21	Using the auto power saving (auto-off) ..	57
Viewing the Picture Coming from		Setting the RF converter .....	58
Your VCR .....	23	Making a Copy of a Tape .....	58
Loading and Unloading Tapes .....	24	Using your HS-U270 to record from	
Playing a Tape .....	25	another VCR .....	59
Playing back a tape .....	25	Using your HS-U270 to play back to	
Using basic playback controls .....	25	another VCR .....	60
Using the On-screen Menu's .....	26	Using Child Lock .....	60
Selecting the On-screen Language .....	26	<b>Chapter Five</b>	
Using the Menus to Set the Time .....	27	<b>Troubleshooting .....</b>	<b>61</b>
		<b>Index .....</b>	<b>63</b>

---

# IMPORTANT SAFEGUARDS

PLEASE READ ALL THESE INSTRUCTIONS REGARDING YOUR VCR AND RETAIN FOR FUTURE REFERENCE. FOLLOW ALL WARNINGS AND INSTRUCTIONS MARKED ON THE VCR.

1. **Read Instructions**  
All the safety and operating instructions should be read before the product is operated.
2. **Retain Instructions**  
The safety and operating instructions should be retained for future reference.
3. **Heed Warnings**  
All warnings on the product and in the operating instructions should be adhered to.
4. **Follow Instructions**  
All operating and use instructions should be followed.
5. **Cleaning**  
Unplug this product from the wall outlet before cleaning. Do not use liquid cleaners or aerosol cleaners. Use a damp cloth for cleaning.
6. **Attachments**  
Do not use attachments not recommended by the product manufacturer as they may cause hazards.
7. **Water and Moisture**  
Do not use this product near water — for example, near a bath tub, wash bowl, kitchen sink, or laundry tub, in a wet basement, or near a swimming pool, and the like.
8. **Accessories**  
Do not place this product on an unstable cart, stand, tripod, bracket, or table. The product may fall, causing serious injury to a child or adult, and serious damage to the product. Use only with a cart, stand, tripod, bracket, or table recommended by the manufacturer, or sold with the product. Any mounting of the product should follow the manufacturer's instructions, and should use a mounting accessory recommended by the manufacturer.
9. **A product and cart combination should be moved with care.** Quick stops, excessive force, and uneven surfaces may cause the product and cart combination to overturn.



10. **Ventilation**  
Slots and openings in the cabinet are provided for ventilation and to ensure reliable operation of the product and to protect it from overheating, and these openings must not be blocked or covered. The openings should never be blocked by placing the product on a bed, sofa, rug, or other similar surface. This product should not be placed in a built-in installation such as a bookcase or rack unless proper ventilation is provided or the manufacturer's instructions have been adhered to.
11. **Power Sources**  
This product should be operated only from the type of power source indicated on the marking label. If you are not sure of the type of power supply to your home, consult your product dealer or local power company. For products intended to operate from battery power or other sources, refer to the operating instructions.
12. **Grounding or Polarization**  
This product may be equipped with a polarized alternating-current line plug (a plug having one blade wider than the other). This plug will fit into the power outlet only one way. This is a safety feature. If you are unable to insert the plug fully into the outlet, try reversing the plug. If the plug should still fail to fit, contact your electrician to replace your obsolete outlet. Do not defeat the safety purpose of the polarized plug.

13. Power-Cord Protection

Power-supply cords should be routed so that they are not likely to be walked on or pinched by items placed upon or against them, paying particular attention to cords at plugs, convenience receptacles, and the point where they exit from the product.

14. Outdoor Antenna Grounding

If an outside antenna or cable system is connected to the product, be sure the antenna or cable system is grounded so as to provide some protection against voltage surges and built-up static charges.

Article 810 of the National Electrical Code, ANSI/NFPA 70, provides information with regard to proper grounding of the mast and supporting structure, grounding of the lead-in wire to an antenna discharge unit, size of grounding conductors, location of antenna-discharge unit, connection to grounding electrodes, and requirements for the grounding electrode.

EXAMPLE OF ANTENNA GROUNDING

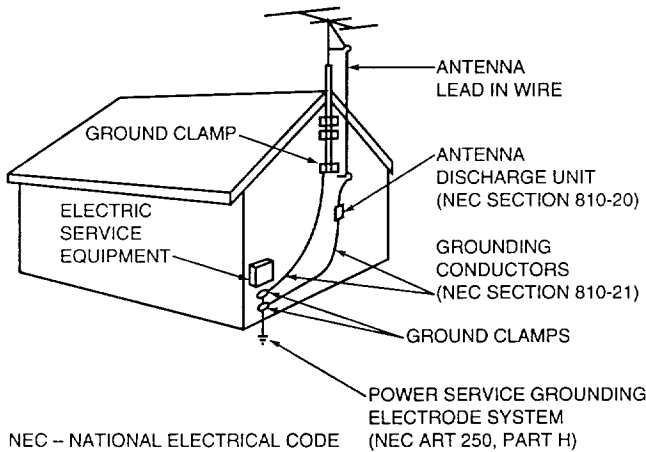

15. Lightning

For added protection for this product during a lightning storm, or when it is left unattended and unused for long periods of time, unplug it from the wall outlet and disconnect the antenna or cable system. This will prevent damage to the product due to lightning and power-line surges.

16. Power Lines

An outside antenna system should not be located in the vicinity of overhead power lines or other electric light or power circuits, or where it can fall into such power lines or circuits. When installing an outside antenna system, extreme care should be taken to keep from touching such power lines or circuits as contact with them might be fatal.

17. Overloading

Do not overload wall outlets, extension cords, and integral convenience receptacles as this can result in a risk of fire or electric shock.

18. Object and Liquid Entry

Never push objects of any kind into this product through openings as they may touch dangerous voltage points or short-out parts that could result in a fire or electric shock. Never spill liquid of any kind on the product.

19. Servicing

Do not attempt to service this product yourself as opening or removing covers may expose you to dangerous voltage or other hazards. Refer all servicing to qualified service personnel.

20. Damage Requiring Service

Unplug this product from the wall outlet and refer servicing to qualified service personnel under the following conditions:

- (a) When the power-supply cord or plug is damaged.
- (b) If liquid has been spilled, or objects have fallen into the product.
- (c) If the product has been exposed to rain or water.
- (d) If the product does not operate normally by following the operating instructions. Adjust only those controls that are covered by the operating instructions as an improper adjustment of other controls may result in damage and will often require extensive work by a qualified technician to restore the product to its normal operation.
- (e) If the product has been dropped or damaged in any way.
- (f) When the product exhibits a distinct change in performance — this indicates a need for service.

## Important Safeguards

---

### 21. Replacement Parts

When replacement parts are required, be sure the service technician has used replacement parts specified by the manufacturer or have the same characteristics as the original part. Unauthorized substitutions may result in fire, electric shock or other hazards.

### 22. Safety Check

Upon completion of any service or repairs to this product, ask the service technician to perform safety checks to determine that the product is in proper operating condition.

### 23. Heat

The product should be situated away from heat sources such as radiators, heat registers, stoves, or other products (including amplifiers) that produce heat.

## CONDENSATION

Leave the VCR on, without a tape in it, for 2 hours if the VCR has been exposed to sudden changes in temperature. Sudden temperature changes cause moisture to form on the metal parts inside the VCR. This moisture can cause the tape to stick and damage the head. Leaving the VCR on for a 2 hour period will dry the inside of the VCR.

## PROTECT THE POWER CORD

Do not damage the power cord. Damage to the power cord may cause a fire or shock hazard. When unplugging the power cord, please hold it by the plug and remove it carefully.

## DO NOT PLACE HEAVY OBJECTS ON THE RECORDER

Heavy objects placed on the recorder will cause damage. (This does not include your cable box.) The top of the recorder is also slotted to provide ventilation. Do not obstruct these ventilation slots.

## WHEN NOT IN USE

When you finish operating the recorder, always unload the cassette and turn OFF the VCR POWER.

## CARE OF THE VIDEO CASSETTE TAPES

- Avoid violent vibration or shock.
- Do not place in a location where strong magnetic fields exist (near a motor, transformer or magnet).
- Never place or store in direct sunlight.
- Avoid dusty places.
- Place the cassette in the cassette case and store vertically.
- Never store tape in a high humidity location.

## INFORMATION

This equipment has been tested and found to comply with the limits for a Class B digital device, pursuant to Part 15 of the FCC Rules. These limits are designed to provide reasonable protection against harmful interference in a residential installation. This equipment generates, uses, and can radiate radio frequency energy and, if not installed and used in accordance with the instructions, may cause harmful interference to radio communications. However, there is no guarantee that interference will not occur in a particular installation. If this equipment does cause harmful interference to radio or television reception, which can be determined by turning the equipment off and on, the user is encouraged to try to correct the interference by one or more of the following measures:

- Reorient or relocate the receiving antenna;
- Increase the separation between the equipment and receiver;
- Connect the equipment into an outlet on a circuit different from that to which the receiver is connected;
- Consult the dealer or an experienced radio/TV technician for help.

Changes or modifications not expressly approved by the party responsible for compliance could void the user's authority to operate the equipment.

If necessary, the user should consult the dealer or an experienced radio/television technician for additional suggestions. The user may find the following booklet prepared by the Federal Communications Commission helpful:

"How to Identify and Resolve Radio-TV Interference Problems."

This booklet is available from the US Government Printing Office, Washington, D.C., 20402, Stock No. 004-000-00345-4.



Congratulations on your purchase of this Mitsubishi Video Cassette Recorder. Your new VCR produces a high resolution VHS picture and is designed for easy operation. Your VCR also includes the VCR Plus+ system and converter box control for simplified programming.

Your owner's guide has been designed with easy-to-follow explanations and directions. In addition, your VCR comes with Mitsubishi's exclusive ▶ViewPoint® on-screen operating system. This system has been developed to simplify the operation of your VCR with clear, understandable language and design.

Thank you for selecting our product and welcome to Mitsubishi.

## ◆ Unpacking Your VCR

As you unpack your new VCR, please make sure the following items are included:

- Remote control

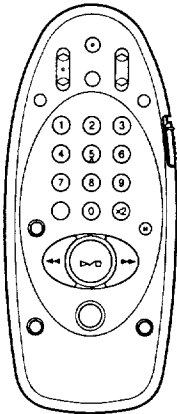

- 2 "AAA" size batteries



- 1 Coaxial cable

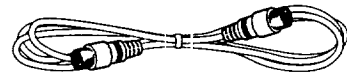

- Registration card

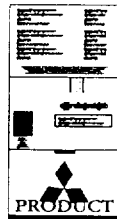

If any of these items are missing, please contact your dealer.

A few suggestions:

- ① Be sure to save the box and packing material your VCR came in. Your VCR should always be transported in this box.
- ② Before you hook up your VCR, please take a few minutes to:
  - complete the registration card and send it back to us immediately,
  - file your sales receipt in a safe place, and
  - place the VCR on a stable surface with sufficient lighting to do the hook-up.

▷ **Important:** Never place any heavy objects on top of the VCR. Do not place the VCR on top of the television.



Now that you have unpacked your player and read through the safety information, it's time to become familiar with the buttons and controls.

If you are experienced with using VCRs, you may just want to glance at this section and refer to it later. If VCRs are new to you, you may want to take your time and become familiar with the locations of all the controls.

On the following pages, you'll find information on:

- ◆ **Front Panel Buttons and Functions**
- ◆ **Fluorescent Display**
- ◆ **Overview of the Remote Control**
- ◆ **Rear Panel Terminals**

### ◆ **Front Panel Buttons and Functions**

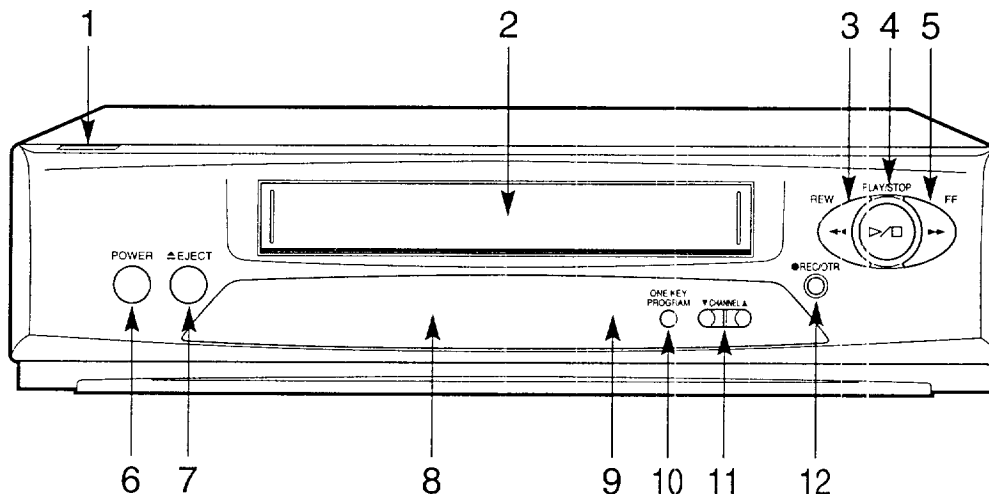

- ① **converter box control transmitter**  
This window (on top of the VCR) transmits signals from your VCR to your cable box or satellite receiver.
- ② **cassette slot**  
This is where you put the video cassette.
- ③ **rewind and reverse search button (REW)**  
Press to rewind a tape or to reverse search. You can also use this button to control the playback speed of a tape.
- ④ **play and stop button (PLAY/STOP)**  
Press this button to play a tape and press again to stop the tape. Also press to stop tape related functions or to resume normal playback from special effects.
- ⑤ **fast forward and fast forward search button (FF)**  
Press this button to fast forward a tape or to fast forward search. You can also use to control the playback speed of a tape.



⑥ **power button (POWER)**  
Press this button to turn the VCR on or off. You must turn the VCR off after you have programmed it to record.

⑦ **eject button (EJECT)**  
Press this button to eject the cassette.

⑧ **fluorescent display**  
See the next section.

⑨ **remote control sensor**  
This receives signals from the remote control. Do not block it.

⑩ **one key program button (ONE KEY PROGRAM)**  
Press to program the VCR to record.

⑪ **channel buttons (CHANNEL)**  
Press these buttons to change channels. Also use these buttons to adjust tracking and picture vibration.

⑫ **record button (REC/OTR)**  
Press this button once to record until the end of the tape. Press repeatedly to set the time for One-Touch Recording (OTR).

### ◆ Fluorescent Display

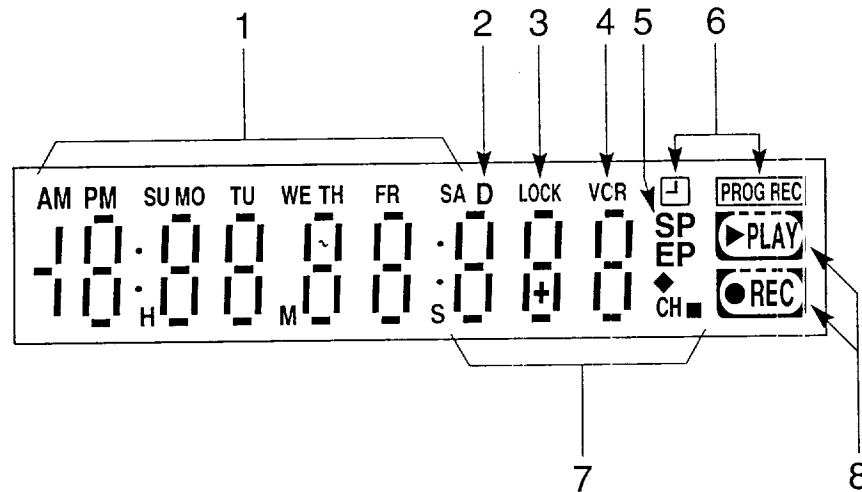

① **counter/present time/remaining display**  
This area displays: the current time; a time counter showing how long the tape has run; the amount of time remaining on the tape; or the contents of a programmed recording when you are programming your VCR.

The current time is displayed when the VCR is turned off or when you press the DISPLAY button. The counter is automatically set to "0H00M00s" when a new tape is loaded. The counter will display "- H - - M - - S" when no tape is in the VCR.

② **digital tracking light (D)**  
This will flash when you first play a new cassette, indicating that the VCR is adjusting the tracking. When tracking is finished, it will glow steadily. If you adjust the tracking manually, it will turn off.

③ **lock light (LOCK)**  
This lights up when the "Child Lock" feature is in use.

④ **VCR light (VCR)**  
This will light up when the VCR/TV button is set to "VCR." It indicates that the antenna signal is being routed through the VCR's tuner.

- ⑤ **tape speed lights (SP, EP)**  
This will light to indicate the tape speed you are using when playing or recording. "SP" indicates standard play; "EP" indicates extended play.
- ⑥ **programmed recording light**  
This lights up when the VCR is off and you have programmed the VCR to record.
- ⑦ **channel display**  
This displays the cable channel, broadcast channel, or input you have selected. If you set up your VCR to receive signals from a satellite receiver, this area can display the

satellite channel you are receiving. The cable tuning light (■) will light up when your VCR is receiving cable broadcasts; the PRIMESTAR® light (◆) will light up when your VCR is receiving signals from a Primestar receiver.

- ⑧ **play and record light and cassette status symbol**  
These light up when the VCR is playing a tape or recording. The symbol (□) will light up when a tape is in the VCR. The dashes in the center of the symbol simulate the movement of the tape when playing and recording.

### ◆ Overview of the Remote Control

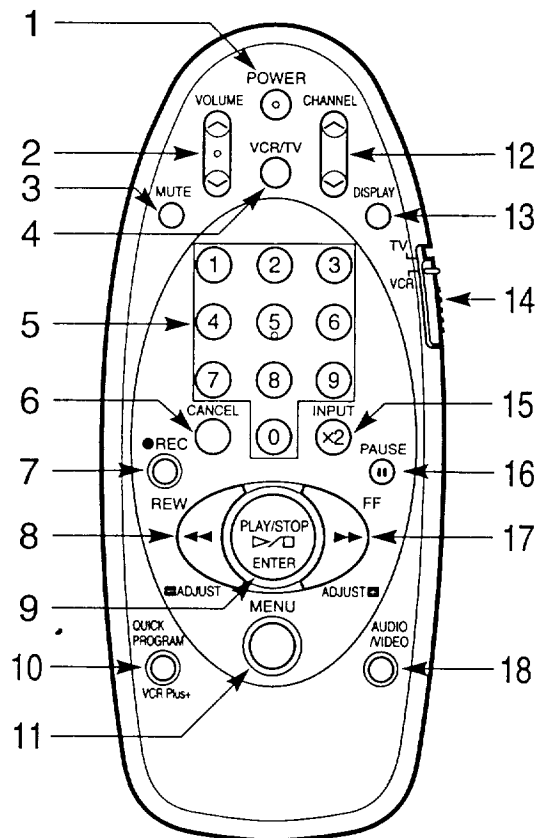

- ① **power button (POWER)**  
Press this button to turn the VCR on or off. If you have programmed the VCR to record, you need to turn the VCR off.

- ② **volume controls (VOLUME)**  
Press the bottom half of this button (indicated by the down arrow) to lower the volume of the TV; press the top half (indicated by the up arrow) to raise the volume of the TV.

- ③ **mute button (MUTE)**  
Press this button to turn off the sound completely or to restore it to its previous volume.

- ④ **VCR/TV button (VCR/TV)**  
Press this button to switch between the VCR's tuner and the TV's tuner. When you select "VCR," you change channels on the VCR; when you select "TV," you change channels on the TV.

- ⑤ **number buttons**  
Use these buttons to select TV stations and to enter PlusCode numbers. Also, use these buttons to set quick searching time.

- ⑥ **cancel button (CANCEL)**  
Use this button to cancel selections on the on-screen menus or to reset the counter display to "0H00M00S."

- ⑦ **record button (REC)**  
Press this button to start recording. When recording, you can use the button to add a manual index mark.

- 
- ⑧ **rewind, reverse search and adjust – button (REW, ADJUST)**  
Press this button to rewind a tape or to reverse search. You can also use this button to control the playback speed of a tape. When using the on-screen menus, use this button to select or adjust items.
- ⑨ **play, stop and enter button (PLAY/STOP, ENTER)**  
Press this button to play a tape and press again to stop the tape. Also press to stop tape related functions or to resume normal playback from special effects. When using the on-screen menus, use this button enter selections.
- ⑩ **quick program and VCR Plus+ button (QUICK PROGRAM/VCR Plus+)**  
This button allows you to program your VCR more quickly and easily. When you press this button, you will immediately see the “Program to record” screen, where you can enter a PlusCode programming number or begin programming your VCR to record.
- ⑪ **menu button (MENU)**  
Press this button to display the menus, which are lists of features and instructions, on your television screen. Also press the button to exit the menus.
- ⑫ **channel buttons (CHANNEL)**  
Press these buttons to change channels.
- ⑬ **display button (DISPLAY)**  
Press this button to display the following information on the television:
- how much time has elapsed on the current tape,
  - the channel number you are watching,
  - the source that is supplying the VCR with a signal,
  - the present time,
  - whether the VCR is stopped, playing, or recording, and
  - how much time is left on the tape.
- This button can also be used to turn on and off the “Child Lock” feature.
- ⑭ **TV/VCR slide switch**  
In addition to operating your VCR, your VCR remote control can be used to operate most of the functions of many brands of televisions. Set to the VCR position to use the remote to operate the VCR. After setting up your remote for your particular brand of television, set to the TV position to use the remote to operate your television. See your TV owner’s guide for more information about operating your TV.
- ⑮ **input button (INPUT)**  
Press this button to select between the antenna and any other video equipment that may be connected. Also, press to begin two times fast playback.
- ⑯ **pause button (PAUSE)**  
Press this button to pause a tape when recording or to freeze a frame when viewing a tape.
- ⑰ **fast forward, fast forward search and adjust + button (FF, ADJUST)**  
Press this button to fast forward a tape or to fast forward search. You can also use this button to control the playback speed of a tape. When using the on-screen menus, use these buttons to select or adjust items.
- ⑱ **function button (AUDIO/VIDEO)**  
Press this button to adjust the VCR’s audio and video functions.

◆ Rear Panel Terminals

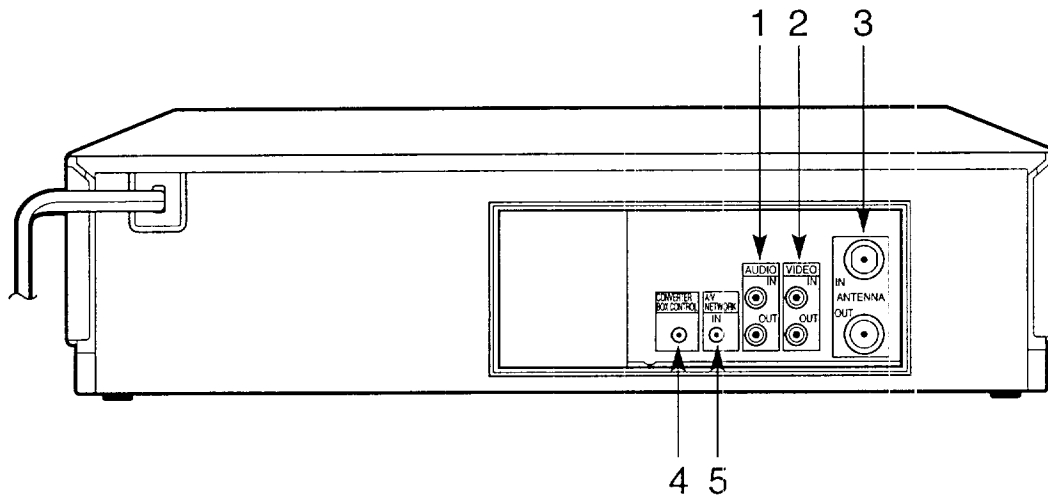

① **audio input and output terminals**

These terminals are called audio inputs and outputs. They enable sound to flow into the VCR (through the audio input) and out to the TV (through the audio output.) You may not need to use these terminals if you have an older TV.

② **video input and output terminals**

These yellow terminals are for sending (OUT) and receiving (IN) video signals. You will only need to use these if you have a monitor television, or for making copies of tapes.

③ **antenna terminals**

• **antenna in (ANTENNA IN)**

Use this terminal to attach an external antenna or cable. This “brings in” an outside signal.

• **antenna out (ANTENNA OUT)**

Use this terminal to attach the VCR to your TV. This terminal “sends out” the signal to your TV.

④ **converter box control terminal (CONVERTER BOX CONTROL)**

Use this terminal to connect a cable that sends signals to a cable box or satellite receiver. (The cable is available from your Mitsubishi dealer, part name, “IR EMITTER.”)

Use this cable if:

- your cable box or satellite receiver cannot receive a signal from the Converter Box Control Transmitter, or
- you would like to place your cable box or satellite receiver away from the VCR.

⑤ **A/V Network input terminal**

Use this terminal to connect the VCR to a Mitsubishi TV that has Active A/V Network terminal or A/V Network terminal.



Now that you're familiar with some of your VCR's features, you're ready to connect the antenna and the television. You won't have to complete all of the connections you see in this chapter — make only those connections that apply to your equipment.

You should keep in mind that there are two steps you need to take to connect your VCR: first, connect the antenna or cable to the VCR, then connect the VCR to the television.

- ◆ Connecting the Antenna or Cable to the VCR
- ◆ Connecting the Television
- ◆ Connecting a DSS® or PRIMESTAR® Receiver (optional)
- ◆ Connecting the A/V Network (optional)

---

## ◆ Connecting the Antenna or Cable to the VCR

The first thing you need to do is connect the antenna or cable. Because there are at least three different types of antennas, this chapter will show how to connect all of them. You don't need to make all the connections. First, find out what kind of antenna you have. Then, make the connection for that type of antenna. You can then go to the next section, "Connecting the Television."

This section shows you:

- Connecting cable antennas,
- Connecting other antennas, and
- Connecting separate UHF/VHF antennas.

### Connecting cable antennas

If you have cable TV, this is the only antenna you need to hook up. Because some cable companies require a cable box (for unscrambling cable signals), there are two kinds of cable connections shown: with and without a cable box.

#### connecting cable without a cable box

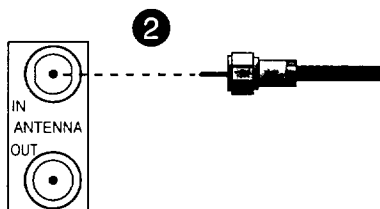

- ❶ Find the "source" cable. It usually comes out of the floor or out of a wall. If it is connected to your TV, disconnect it.
- ❷ Connect the cable to the ANTENNA IN terminal on the back of your VCR. Screw or push the cable onto the terminal until it is tight.
- ❸ When you are finished, go to page 14, "Connecting the Television."

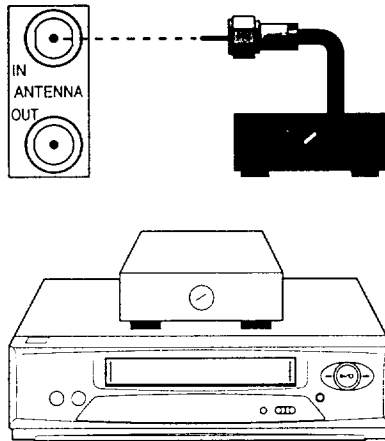

### connecting cable with a cable box

If your cable system requires you to use a cable box, follow the directions below to connect your cable box to your VCR:

- ❶ Disconnect the cable box from the TV.
- ❷ Connect the cable coming from the cable box to the ANTENNA IN terminal on the back of your VCR. Screw or push the cable onto the terminal until it is tight.
- ❸ Place the cable box on the center of the top of the VCR. Place the rear of the cable box flush with the rear of the VCR. Make sure the cable box doesn't obstruct the VCR's ventilation slots.
- ❹ When finished, go to page 14, "Connecting the Television."

If your cable box has audio and video outputs, follow the additional directions below.

- ❺ Connect one audio cable to the left audio output terminal on the cable box. Connect the other end of this cable to the AUDIO INPUT terminal on the VCR.
- ❻ Connect one video cable to the video output terminal on the cable box. Connect the other end of this cable to the VIDEO INPUT terminal on the VCR.

Audio and video cables are available at your local electronics store.

▷ **Important:** If you plan to connect a satellite receiver to your VCR, you cannot connect a cable box using audio and video cable. In this case, connect the cable box using only antenna cable. (You only follow the instructions ❶ through ❹ above.)

▷ **Important:** If you need a cable box to descramble all cable channels, you can't record one channel while watching another. If you have questions concerning your cable system, please contact your cable company.

### Connecting other antennas

If you don't have cable TV, you'll need to connect a regular antenna. Your antenna may have one of two different kind of ends (called "leads") on it. The two kinds of leads are:

300-ohm flat twin leads  
that look like this ... :



... or a 75-ohm round lead  
that looks like this:



Follow the procedures for connecting the kind of leads your antenna has, then go to page 14, "Connecting the Television."

### connecting an antenna with a 300-ohm flat twin lead

(If you have a 300-ohm flat twin lead, you will need to purchase a 300-75 ohm adapter at your local hardware or electronics store.)

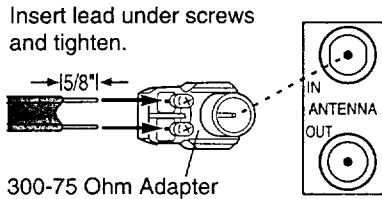

- ❶ Disconnect the antenna from the back of the TV.
- ❷ Before you can attach the antenna leads to the adapter, you need to expose a 5/8 inch segment of each lead by scraping off the brown plastic covering. Sometimes these leads have "U" shaped clips that fit around the screw, in which case you will not need to peel back the plastic.

Wrap each exposed end of wire once or twice around the screw shanks of the adapter (or insert the clips under the screw heads). Tighten the screws.

- ❸ Push the adapter firmly onto the antenna terminal on the VCR labeled ANTENNA IN.
- ❹ Go to page 14, "Connecting the Television"

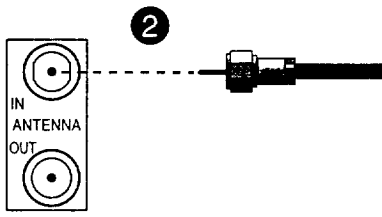

### connecting an antenna with a 75-ohm round lead

- ❶ Disconnect the antenna from the back of the TV.
- ❷ Connect the antenna to the ANTENNA IN terminal on the back of the VCR. Screw or push the cable until it is tight.
- ❸ Go to page 14, "Connecting the Television."

### Connecting separate UHF/VHF antennas

You may have two separate antennas (one UHF, one VHF) that bring TV signals into your home. If you do, you'll need to combine the two antennas before connecting them to the VCR. To do this, you'll need an attachment called a combiner (which is available at your electronics store). This chart below will help you determine the kind of combiner you need.

if your UHF antenna wire looks like this...	... and your VHF antenna wire looks like this ...	... then you need a combiner like this.

To connect your antennas:

- ❶ Disconnect the antennas from the back of the TV.
- ❷ Connect the antenna leads onto the combiner.
- ❸ Screw or push the combiner onto the ANTENNA IN terminal on the VCR.
- ❹ See “Connecting the Television,” below.

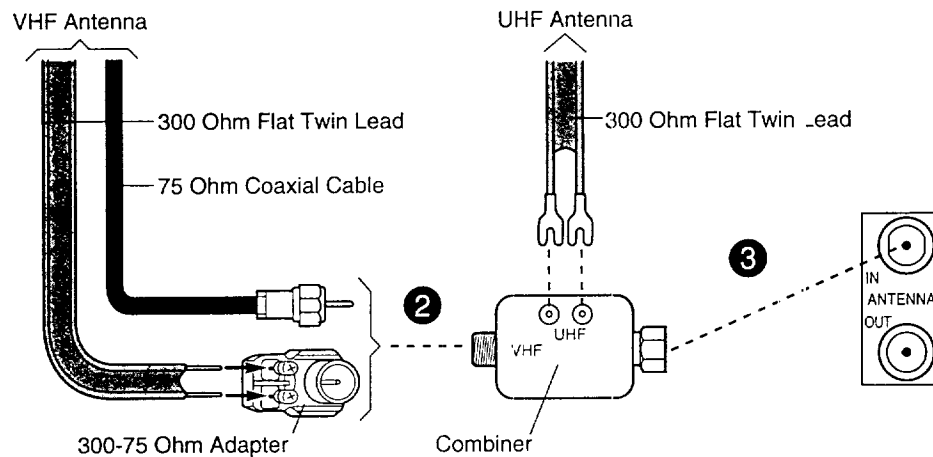

## ◆ Connecting the Television

Now that you have completed the antenna connections to your VCR, you're ready to connect the VCR to the TV. (If you haven't connected the antenna to the VCR, go to page 11, "Connecting the Antenna or Cable to the VCR.") Because every television is different (especially older model TVs), your VCR may need to be connected in one of a variety of ways. This section shows you:

- Determining if you need a splitter,
- Connecting an older TV without audio and video inputs to the VCR, and
- Connecting a modern TV with audio and video inputs.

### Determining if you need a splitter

You should look at the back panel of your TV to see if you need any special equipment to connect the TV to the VCR. You may need an attachment called a UHF/VHF splitter (which is available at your local electronics store).

The chart on the next page will tell you if you need a splitter, and what the splitter will look like.

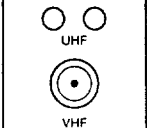
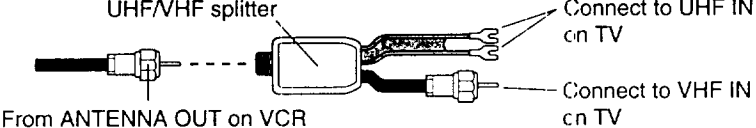
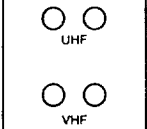
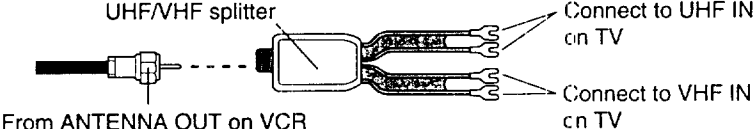

If the TV's antenna terminal looks like this...	... then you will need splitter that looks like this.
	<p style="text-align: center;">No splitter needed</p>
	
	

### Connecting an older TV without audio and video inputs to the VCR

- ❶ Take the black cable (called a coaxial cable) that is supplied with your VCR and attach it to the terminal labeled ANTENNA OUT on the back of your VCR.
- ❷ Connect the other end of this cable to the terminal on your TV labeled ANTENNA IN. This terminal is sometimes also called "ANT-IN" or "VHF IN." If you have an older TV without this kind of terminal, you will have to use a splitter and then connect the splitter to the television.
- ❸ If you have a TV with audio and video inputs, you should proceed to the next section, "Connecting a modern TV with audio and video inputs." Otherwise, your connections are complete.

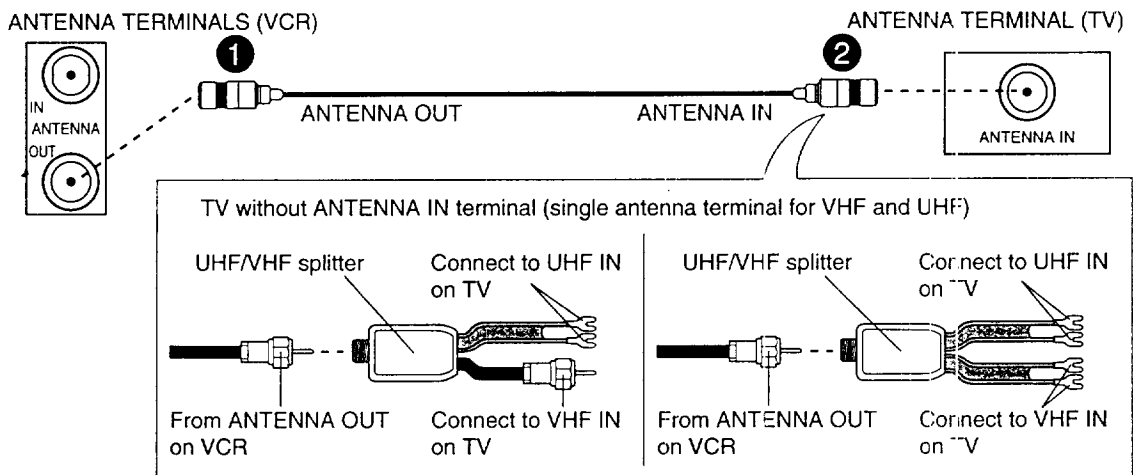

### Connecting a modern TV with audio and video inputs

Your new VCR can be connected to many different types of televisions. If your TV has audio and video inputs, you will want to connect your VCR to these inputs to take advantage of your VCR's superior picture and sound. (To make these connections you will need to purchase audio and video cables from your local electronics dealer. The cables are also known as RCA type cables.)

Before you begin this section:

- You should have already completed the section "Connecting an older TV without audio and video inputs to the VCR."
- ❶ Connect an audio cable to the AUDIO OUTPUT terminal on the VCR labeled AUDIO OUT.
  - ❷ Connect the other end of this cable to the AUDIO INPUT terminal on your TV labeled AUDIO IN.
  - ❸ Connect a yellow video cable to the VIDEO OUTPUT terminal labeled VIDEO OUT on the VCR.
  - ❹ Connect the other end of the video cable to the yellow VIDEO INPUT terminal labeled VIDEO IN on the TV.

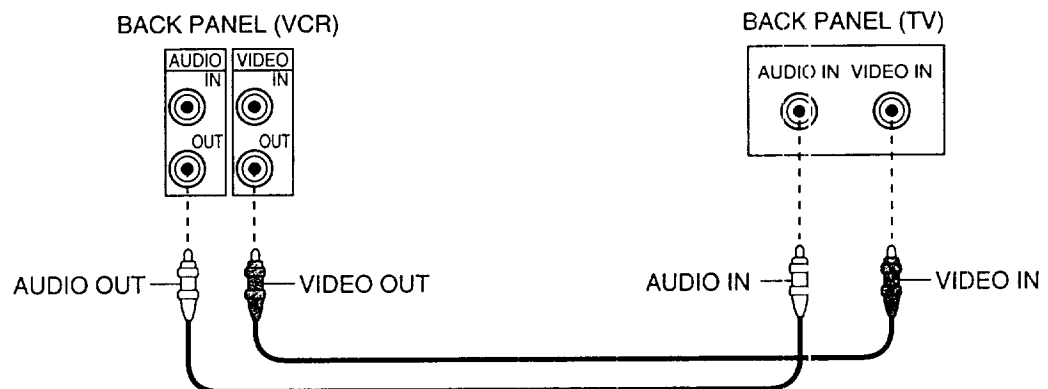

### ◆ Connecting a DSS® or PRIMESTAR® Receiver (optional)

If you have an RCA, Sony, or PRIMESTAR Satellite Receiver, you can connect the receiver to your VCR. This will not only allow you to record TV programs coming from the receiver, but it will allow you to control the receiver through the VCR.

#### connecting a DSS or PRIMESTAR receiver

To connect the satellite receiver, you should use a video cable and an audio cable to preserve the maximum signal quality. You can purchase these cables at your Mitsubishi dealer or at your local electronics store.

**before you begin, you should:**

- have completed all connections between your VCR, TV, and cable or antenna; (see pages 11-16) and
- make sure that your satellite receiver has been installed correctly. (See your satellite receiver's manual for more information.)

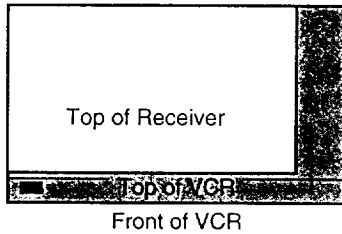

- 1 Place the satellite receiver on top of your VCR. Align the rear of the receiver with the rear of the VCR and align the left side of the receiver with the left side of the VCR. If your VCR is smaller than your satellite receiver you will need to purchase an IR emitter (part name:IR EMITTER) from your Mitsubishi dealer.
- 2 Connect an audio cable to the left audio output terminal on the receiver; connect the other end of the cable to the terminal on the rear panel of the VCR labeled AUDIO IN .
- 3 Connect a video cable to the video output terminal on the receiver; connect the other end of the cable to the terminal on the rear of the VCR labeled VIDEO IN.

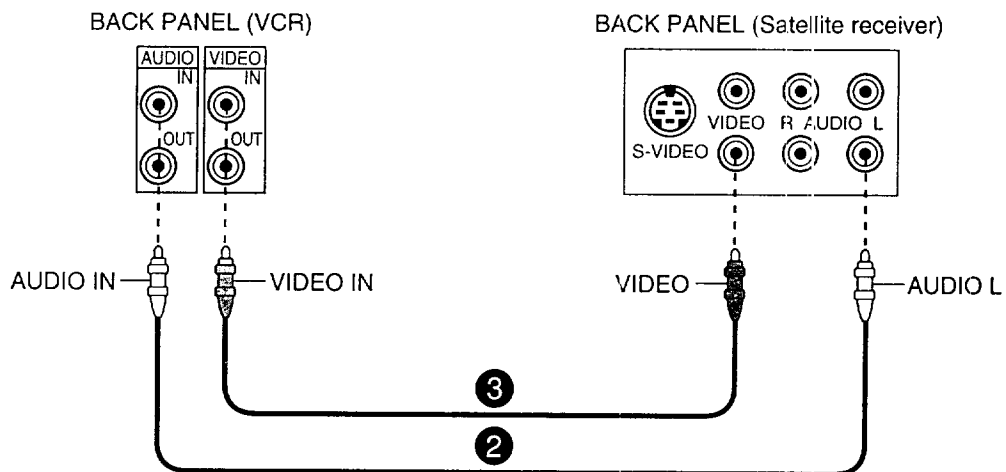

- ▷ **Important:** You will have to turn your VCR on to watch the video signal or to hear the audio signal from the satellite receiver.
- ▷ **Important:** After you have connected the satellite receiver and completed the "Memorize Channels" procedure (on pages 29-32), you need to see if your VCR can control your receiver. To do this, use the CHANNEL buttons or number buttons on the VCR remote to tune to a satellite channel. If the satellite channels appear on your TV, then your VCR can control your receiver. If they don't appear, you will need to purchase an IR emitter (part name: IR EMITTER) from your Mitsubishi dealer.
- ▷ **Important:** If you use a cable box and a satellite receiver, be sure to connect the IR emitter described below.

**connecting an IR emitter**

Connect the IR emitter to the CONVERTER BOX CONTROL terminal on the back of the VCR. Run the emitter to the satellite receiver. Place the emitter so that the bulb faces the IR window on the receiver. Finally, follow the instructions in the paragraph above to test your VCR's ability to control your satellite receiver. You can use the other emitter for the cable box, otherwise, store it out of the way.

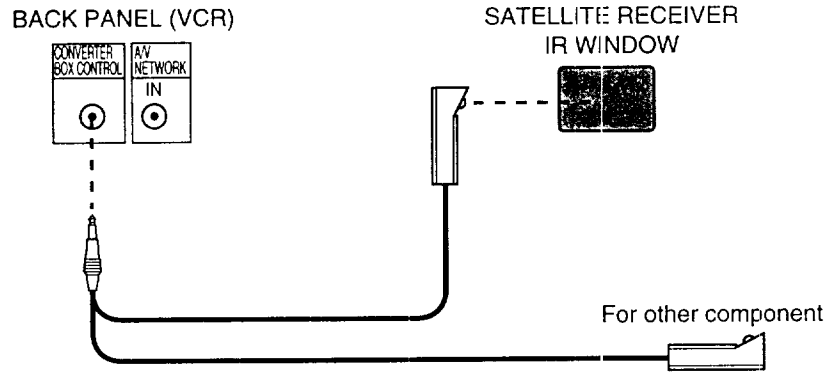

◆ **Connecting the A/V Network (optional)**

Some Mitsubishi TVs and VCRs have special terminals called the "A/V Network." The primary purpose of the A/V Network is to "pass" remote control codes between Mitsubishi components. That is, when the A/V Network is connected, you can point your VCR remote control at the TV, and the TV will "pass" the commands on to the VCR.

To connect the A/V Network, you will need a cable with a "mini" jack at both ends. (A mini jack is the kind you find on headphones for personal stereos.) A cable may be included with your Mitsubishi TV. If not, you can purchase a cable with mini jacks at your Mitsubishi dealer or an electronics store.

To connect the A/V Network:

Connect a cable to the terminal on the TV labeled A/V NETWORK OUT or ACTIVE A/V NETWORK. Connect the other end of the cable to the terminal on the VCR labeled A/V NETWORK IN.





Now that you've completed your antenna, VCR, and TV connections, you're ready to start enjoying your equipment. To get the most satisfaction out of your VCR, you should carefully read the two sections, "Setting Up Your VCR for the First Time" and "Viewing the Picture Coming from Your VCR." Then you can start exploring what your new VCR can do.

In this chapter, you'll learn:

- ◆ **Setting Up Your VCR for the First Time**
- ◆ **Using the Remote Control**
- ◆ **Viewing the Picture Coming from Your VCR**
- ◆ **Loading and Unloading Tapes**
- ◆ **Playing a Tape**
- ◆ **Using the On-screen Menu's**
- ◆ **Selecting the On-screen Language**
- ◆ **Using the Menus to Set the Time**
- ◆ **Programming the VCR to Receive TV Channels**
- ◆ **Using the Audio and Video Functions**
- ◆ **Setting the VCR Plus+ Guide Channel Numbers**
- ◆ **Recording**

---

## ◆ **Setting Up Your VCR for the First Time**

It's important that your VCR is set up correctly before you try to use it. If you carefully read this section, you will avoid confusion later and get the most out of operating your system.

This section teaches you about:

- Setting up your VCR if you are using a TV without Audio and Video Inputs (Older TV),
- Setting up your VCR if you are using a TV equipped with Audio and Video Inputs (Modern TV).

Before you begin, you should:

- have completed your antenna, VCR, and TV connections.

### **Setting up your VCR if you are using a TV without Audio and Video Inputs (Older TV)**

- ❶ Turn on your TV and tune it to channel 3 or 4, whichever is NOT used for broadcast in your area.

- ② If you tuned the TV to channel 4 in step ①, press the CHANNEL ▲ button and the ONE KEY PROGRAM button on the front panel at the same time with the VCR tuned off. The word “Ant ch4” will display on the front panel display and the VCR will send signals on channel 4. (If you tuned the TV to channel 3, you don’t need to do this.)
- ③ Turn the VCR on by pressing the POWER button.

▷ **Important:** The VCR will return to its initial setting (channel 3) if you press the CHANNEL ▼ button and the ONE KEY PROGRAM button on the front panel at the same time with the VCR turned off.

### Setting up your VCR if you are using a TV equipped with Audio and Video Inputs (Moden TV)

- ① Turn on your TV and switch it to the correct external input. (For most Mitsubishi TVs, this means pressing the TV’s INPUT button until you see the words “Ext-1” on the screen.)
- ② Turn the VCR on by pressing the POWER button.

## ◆ Using the Remote Control

In this section, you’ll learn how to set up and use your remote control. This section includes:

- Using the remote control to operate the VCR, and
- Using the remote control to operate the TV.

### Using the remote control to operate the VCR

#### installing the batteries

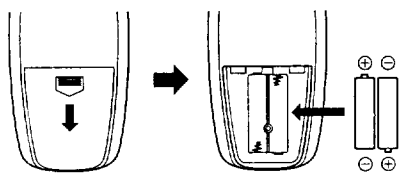

- ① Unpack two AAA size batteries.
- ② To remove the back cover, press the ridged area gently, then push the cover in the direction of the arrow and lift.
- ③ Load the batteries, making sure the polarities (+) and (–) are correct.

#### operating the remote control

The HS-U270 has two VCR operation modes: VCR-A mode and VCR-B mode. The HS-U270 is pre-set to VCR-A operation mode.

- ① Set the TV/VCR slide switch on the remote control to VCR position. This “tells” the remote that you want to control the VCR.
- ② Press the DISPLAY button and the number button “1” on the remote control at the same time. Now your remote is ready to operate your HS-U270.

- 
- 3 While within 23 feet of the VCR, point the remote control toward the VCR and press the buttons you desire.

#### using one remote to operate two Mitsubishi VCRs

If you have another Mitsubishi VCR in addition to your HS-U270, you can use the HS-U270 remote control to operate both. You will need to do some preparation to operate the two VCRs separately with one remote.

- 1 Set the remote mode on the HS-U270 to "VCR-B" operation mode. With the VCR turned off, press the ONE KEY PROGRAM button and REW button on the front panel at the same time. (The letter "b" will appear on the front panel display to indicate that the HS-U270 becomes the VCR-B mode.)
- 2 Set the remote mode on the other Mitsubishi VCR to "VCR-A" operation mode. With the VCR turned off, press the ONE KEY PROGRAM button and FF button on the front panel at the same time. (The letter "A" will appear on the front panel display to indicate that the other Mitsubishi VCR becomes VCR-A mode.)

OR:

If the other Mitsubishi VCR has a REMOTE switch, you only set the switch to "VCR-A" or "ON" position. If it does not have a REMOTE switch, do not change any settings. (VCR's without a remote switch are already set to VCR A.)

- 3 To operate the HS-U270, set the TV/VCR slide switch to VCR position on the remote control and then press the DISPLAY button and the number button "2" at the same time. The remote will be set to control the HS-U270.
- 4 To operate the other VCR, set the TV/VCR slide switch to VCR position on the remote control and then press the DISPLAY button and the number button "1" at the same time. The remote will be set to control the other VCR.

If the other Mitsubishi VCR has a VCR button, you can use the VCR button instead of using the TV/VCR slide switch.

#### Using the remote control to operate the TV

The HS-U270 remote control can operate many of the frequently-used functions of your TV. This way, you need to use only one remote to operate both your VCR and TV.

The HS-U270 remote control is pre-set to operate Mitsubishi televisions, but it can also operate TVs from other manufacturers. If you need to set your remote control for your particular brand of television, follow the instructions below.

Brand of TV	Brand code buttons
Mitsubishi	1, 2, 3
Fisher	0
G.E.	CANCEL
Goldstar	2, 9
Hitachi	8
JVC	VOLUME √
Magnavox	4
NEC	2, 9
Panasonic	6, MUTE
Pioneer	CHANNEL √
Philips	4
Proscan	CANCEL
Quasar	6
RCA	CANCEL
Sanyo	0
Sharp	3, 5
Sony	DISPLAY
Toshiba	7
Zenith	INPUT

#### setting up your remote control to operate your TV

- ❶ Turn off your TV.
- ❷ On the HS-U270 remote control, set the TV/VCR slide switch to TV position.
- ❸ While holding in the POWER button, press the code button listed to the left that corresponds to the brand of your TV.
- ❹ Once your TV has turned on, your remote is set up to operate your brand of TV.

You do not need to perform this set-up again unless you change the batteries, set up your remote for another brand of television, or you get a new TV.

Once you have correctly set your remote control to operate your TV, you will be able to use the POWER, CHANNEL, VOLUME, MUTE and number buttons to operate your TV.

- ▷ **Important:** Depending on the model TV you have, all or some of the buttons may not function, or they may operate different features than indicated above. You may need to use the TV's remote control.
- ▷ **Important:** Sometimes manufacturers will change the remote control codes for their products, or they will use more than one code. If this is the case, your remote may not be able to control your TV.
- ▷ **Important:** When you replace the batteries in your remote, the remote will return to its initial setting (code button "1"). Repeat the steps above to reset your remote control. If you enter a new code, the previous code will be erased.

#### operating your TV with the HS-U270 remote control

- ❶ Set the TV/VCR slide switch to TV position on the HS-U270 remote control.
  - ❷ Point the remote control towards the remote sensor on the TV and press the desired buttons.
  - ❸ To once again control the VCR, set the TV/VCR slide switch to VCR position.
- ▷ **Important:** Because of variations among models, some or all buttons may not work, or they may operate different functions than listed above, for your particular TV. If this occurs, you may need to use your TV remote control.



## ◆ Viewing the Picture Coming from Your VCR

This is the most important part of using your VCR, but often the most confusing: how do you view a picture coming from the VCR?

Before you begin, you should know:

- whether you are viewing an “Older TV” or a “Modern TV”.

### Viewing the picture coming from your VCR if you are using an older TV

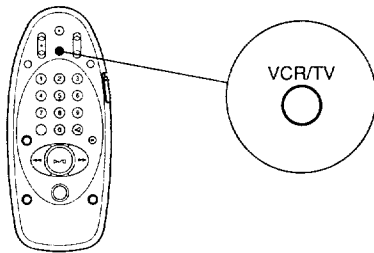

- ❶ Turn on your TV and tune it to channel 3 or 4.
- ❷ Turn on the VCR by pressing the POWER button.
- ❸ Check to see if the “VCR” light on the front panel display is lit. If it is not lit, press the VCR/TV button until it is lit. You are viewing the picture from your VCR!

With this set-up, you will use the VCR/TV button when recording, when viewing tapes or broadcast stations through your VCR, or before using the VCR’s menus. You also use the VCR/TV button to switch back to normal TV viewing.

▷ **Important:** If you set the “RF converter” setting of the “Customize choices” menu to ON, you don’t need to use the VCR/TV button when viewing tapes.

### Viewing the picture coming from your VCR if you are using a modern TV

- ❶ Turn on your TV and switch it to the correct external input. (For most Mitsubishi TVs, this means pressing the TV’s INPUT button until you see the words “Ext”, “Input”, or “Video” on the screen.)
- ❷ Turn the VCR on by pressing the POWER button.

You are viewing the picture from your VCR!

If you wish to return to normal TV viewing, switch your TV’s input back to its previous position.

▷ **Important:** If you are using a modern TV, be sure to set the “RF converter” of the “Customize choices” menu to OFF to prevent noise in the picture.

▷ **Important:** If your system includes a home theater receiver or an A/V receiver, refer to your home theater receiver’s owner’s guide.

## ◆ Loading and Unloading Tapes

### Loading a tape

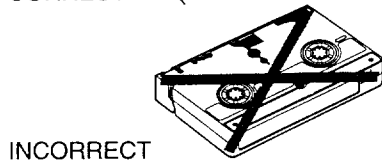
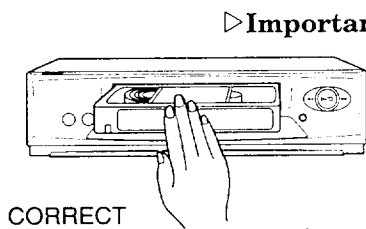

► **Important:** Tapes can be loaded into your VCR as long as the VCR is plugged in. Even when the VCR POWER is off, loading a tape will automatically turn the VCR on. Use only tapes that have a **VHS** label.

- 1 Hold the tape so that the long narrow edge with the contents label faces towards you. The other edge is hinged and should face towards the VCR. The plastic window that shows the videotape should face up.
- 2 Gently insert the tape into the cassette slot until the VCR automatically takes it in.

► **Important:** Your VCR will eject the tape if you improperly load it. If the VCR ejects the tape, remove the tape, check to see that the contents label is facing you, that the geared tape reels are facing downwards, wait a few seconds, and try again.

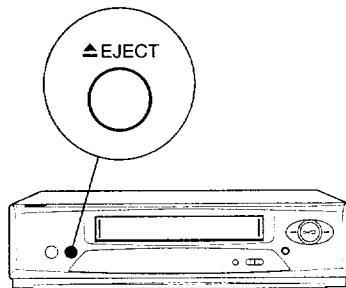

### Unloading a tape

- 1 Press the EJECT button on the front of the VCR. If the VCR POWER is off, the VCR will turn on, eject the tape, then turn off.
- 2 Remove the tape.

► **Important:** You cannot eject a tape while it is recording. You must first stop the recording.

### Preventing accidental erasure

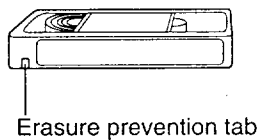

Tapes come with a tab that, when removed, prevents you from recording on the tape. If you attempt to record over a tape that has had this tab removed, the VCR will eject the tape. To record over such a tape, simply place a piece of vinyl tape over the opening.

### Using repaired tapes

► **Warning:** We recommend that you take any broken or torn tapes to a professional for repair. If you repair a torn tape with improper materials, you could damage your VCR when you play the tape.

### Head cleaning

Your VCR automatically cleans the head and the drum of the VCR whenever you load a tape. If you see “noise” or snow when playing a tape, eject the tape, re-load the tape, then wait 3 or 4 seconds. Repeat this process several times to improve the picture.

## ◆ Playing a Tape

Now that your VCR is connected and properly set up, and you know how to view a picture coming from your VCR, it's time to play a tape. This section describes:

- Playing back a tape, and
- Using basic playback controls.

### Playing back a tape

Before you begin, you need to know:

- how to view the picture coming from your VCR (page 23).

- ❶ To play a tape, load a pre-recorded cassette.
- ❷ Press the PLAY/STOP button on the front panel or on the remote control.

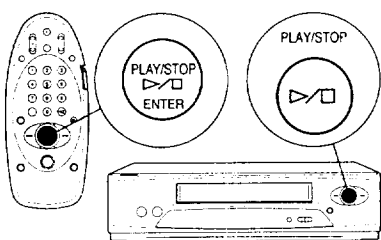

The VCR will automatically play the tape at the correct speed. When the VCR reaches the end of the tape, it will automatically rewind the tape and stop. You can stop playing by pressing PLAY/STOP.

▷ **Important:** If you are playing a tape on a TV using Active AV Network, your TV screen may blank out for a fraction of a second when you press PLAY/STOP. This is normal and will not harm either the TV or VCR.

### Using basic playback controls

#### rewinding a tape

Press the REW button on the remote control or on the front panel.

If the tape is stopped, you will begin rewinding. If the tape is playing, you will begin "reverse speed search."

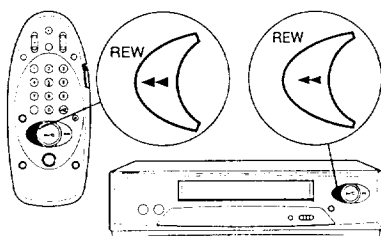

#### fast forwarding a tape

Press the FF button on the remote control or on the front panel.

If the tape is stopped, you will begin fast forwarding. If the tape is playing, you will begin "forward speed search."

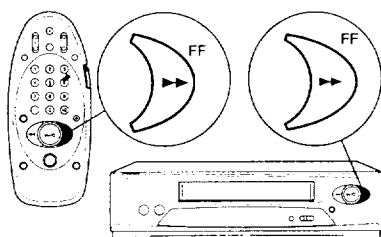

#### pausing a tape

Press the PAUSE button on the remote control to freeze the picture on the screen.

▷ **Important:** If you leave the VCR in pause for 5 minutes, the VCR will automatically stop to prevent damage to the tape.

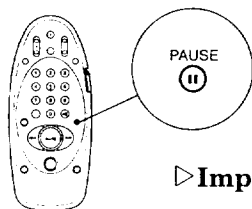

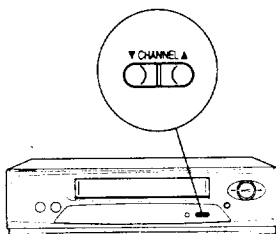

#### controlling vibration during still frame

If the picture vibrates during still frame, press the CHANNEL buttons on the front panel until the picture is steady.

### ◆ Using the On-screen Menu's

When using the on-screen menu with your remote control, you will use the FF and REW buttons as your ADJUST buttons and you will use the PLAY/STOP button as your ENTER button.

- ▷ **Important:** If you are seeing the on-screen menu on your TV using Active A/V Network, your TV screen may flash momentarily when using the PLAY/STOP (ENTER) button. This is normal and will not harm either the TV and VCR.

### ◆ Selecting the On-screen Language

You can set your VCR to display on-screen messages, menus, and functions in English, Spanish or French. You should do this before you use the menus or set any audio/video functions.

Before you begin, you need to know:

- how to view the picture coming from your VCR. (See page 23.)
- 1 Make sure you are viewing the picture coming from your VCR. Then, press the MENU button on the remote control. If this is the first time the menus have been used, you will see the menu for selecting an on-screen language.
  - 2 Press the ADJUST buttons on the remote control to highlighted the desired language. The ADJUST + button moves upward; the ADJUST - button moves downward.
  - 3 Press the ENTER button on the remote control. The menu will change to the "VCR Main Menu."
  - 4 Press the MENU button to exit the menus.

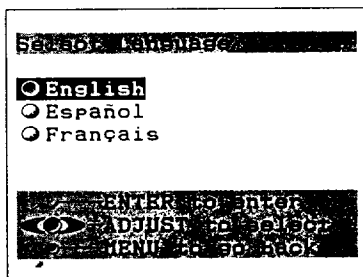

- ▷ **Important:** The "Select Language" menu is unique. While all other menus can be accessed at almost any time, the "Select Language" menu will not automatically appear again after it is first set. To see the "Select Language" menu, turn off the VCR and unplug the power cord. Leave it unplugged for about two minutes, then follow the procedure on this page.

## ◆ Using the Menus to Set the Time

This section will show you how to use the on-screen menus. You will use the menus to operate many features, such as setting the time, programming to record, and memorizing channels. On the on-screen menus, the selected item is indicated in white.

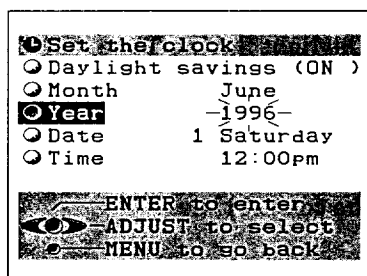
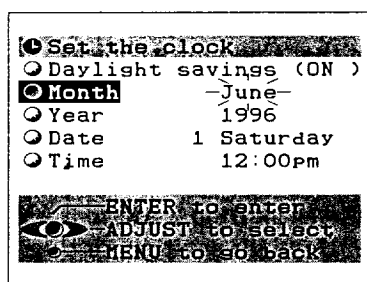
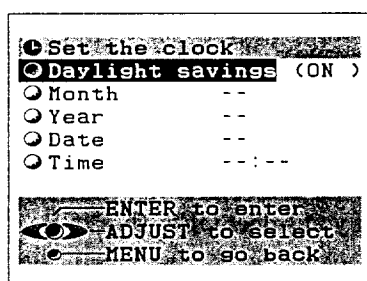
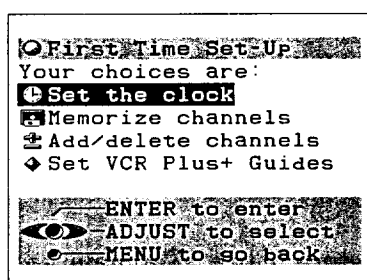
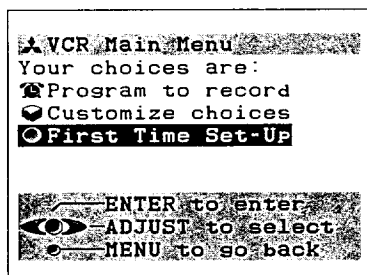

Before you begin, you need to know:

- how to view the picture coming from your VCR (page 23).
- 1 Make sure you are viewing the picture coming from your VCR. Then, press the MENU button on the remote control. You will see the "VCR Main Menu." Make sure the words "First Time Set-Up" are highlighted. If it is not, use the ADJUST buttons to highlight it.
  - 2 Press the ENTER button. The "First Time Set-Up" menu will appear. The word "Set the clock" are highlighted. Press the ENTER button.
  - 3 You will see the "Set the clock" menu. The words "Daylight savings" will be highlighted. Press the ADJUST buttons to select the daylight savings setting ON or OFF. IF you are currently following daylight savings, select ON. Otherwise, select OFF. Press the ENTER button.
  - 4 Press the ADJUST buttons until the correct month appears on screen. Press the ENTER button.
  - 5 Press the ADJUST buttons to set the year. Press the ENTER button.

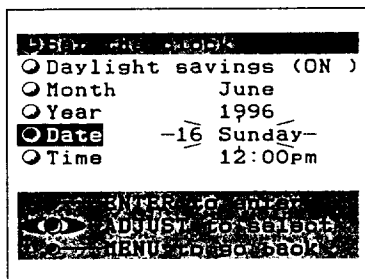

- 6 Press the ADJUST buttons to set the date. Press the ENTER button.

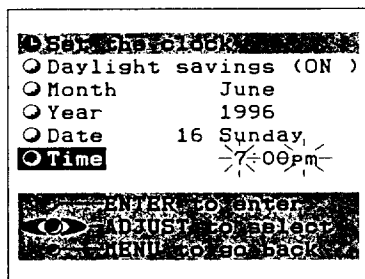

- 7 The hour numbers and the am/pm indicator will be blinking. Press the ADJUST buttons to set the hour and am/pm at the same time. The ADJUST + button moves the clock forward; the ADJUST - moves the clock backwards. Press the ENTER button.

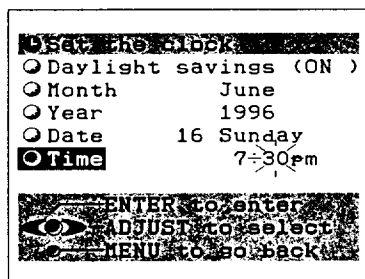

- 8 The minutes numbers will now be blinking. Press the ADJUST buttons to set the minutes. When you have set the correct time, press the ENTER button. The display will return to the “First Time Set-Up” menu and the clock will start running.
- 9 Press the MENU button once to return to the “VCR Main Menu”; press the MENU button again to turn off the menus.

#### If you want to adjust the clock manually for Daylight Saving Time

After you have displayed the “Set the Clock” menu, make sure that the words “Daylight savings” is highlighted. Then press the ADJUST buttons to select ON or OFF. If you select ON, the VCR will set the clock forward one hour. If you select OFF, the VCR will set the clock back one hour.

- ▷ **Important:** If you want the VCR to adjust the clock automatically for Daylight Saving Time, set “Auto D.S.T.” of the “Customize choices” menu to ON.

If you set the “Auto D.S.T.” of the “Customize choices” menu to ON,

Your VCR will change automatically the clock from 2 AM to 3 AM on First Sunday in April and turn the “Daylight savings” setting to ON; your VCR will change the clock from 3 AM back to 2 AM on Last Sunday in October and turn the setting to OFF. This means if you are currently following Daylight Saving Time, “ON” will be displayed; otherwise, “OFF” will be displayed. (You cannot change the “Daylight savings” setting manually.)

- ▷ **Important:** If any time you adjust this setting, check your programmed recordings to be sure they are set to the correct time.

## ◆ Programming the VCR to Receive TV Channels

Before your VCR can receive television channels, you need to program all of the local channels you can receive into your VCR. Fortunately, our menu system makes this an easy process. This section will also explain some other channel-related functions.

This section explains:

- Programming channels automatically,
- Using video mute,
- Adding and deleting channels, and
- Selecting a channel.

### Programming channels automatically

Using this process, your VCR will automatically tune in all of the television stations you can receive. You can later get rid of unwanted or unused stations.

*If your local cable box company scrambles some or all stations, and/or requires you to use a cable box, then your ability to program channels will be limited. The cable box receives all of your channels and then sends only one to your TV (and your VCR), usually on channel 3 or 4.*

*If you are required to use a cable box, you should choose “Cable box only” option in step 5 on the next page. Your HS-U270 will use its special Converter Box Control technology to change the channels on the cable box.*

*If your cable box or cable system seems incompatible with your new VCR, call your cable company. They may be able to provide solutions to your problems.*

Before you begin, you should:

- have completed all connections between your VCR, TV, cable, antenna, cable box, and satellite receiver (if any); (pages 11-18)
- know how to view the picture coming from your VCR; (page 23)
- know how to use the menus. (See page 26.)

To program channels automatically:

- 1 Press the MENU button on the remote control. You will see the “VCR Main Menu” on the TV screen.
- 2 Use the ADJUST buttons on the remote to select “First Time Set-Up.” Press the ENTER button.
- 3 The “First Time Set-Up” menu appears on your screen. Press the ADJUST buttons to select “Memorize channels.” Press the ENTER button.

### A special note to cable box subscribers

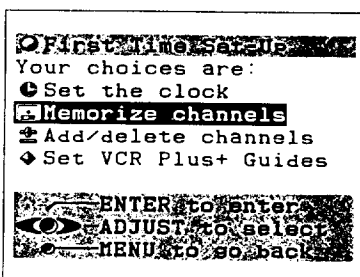
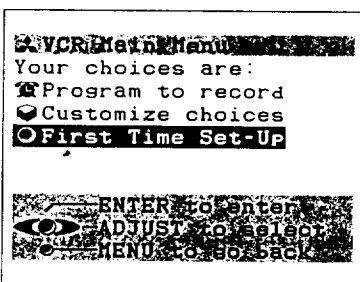

▷ **Important:** If you are recording or playing back a tape, the words “Not available” will flash. To correct this, stop the tape.

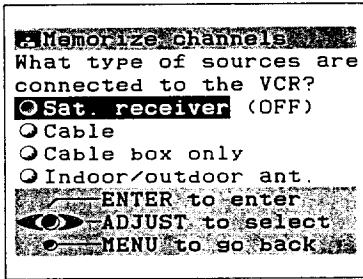

- 4 You will see the menu for automatically memorizing channels. If you are using a satellite receiver, press the ADJUST buttons to select “Sat. receiver.” Then use ENTER button to select correct code for your satellite receiver. Select “1” if you are using an RCA satellite receiver; select “2” if you are using a Primestar satellite receiver; and select “3” if you are using a Sony satellite receiver. Now you can select all of the channels coming from your satellite receiver.

If you are not using a satellite receiver, make sure “Sat. receiver” is set to “OFF.”

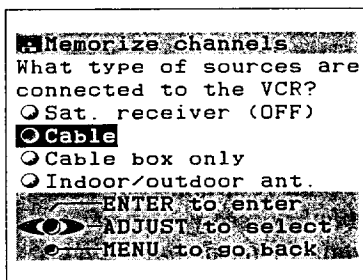

- 5 Using the list below as a reference, press the ADJUST buttons to select the kind of antenna you connected.
  - If you are using a cable box that sends signals to your VCR on only one channel and can be operated by a remote control, choose “Cable box only,” and skip to step 7, below.
  - If you are using any other cable combination, including a cable box with an A/B switch, choose “Cable.”
  - If you are using an antenna that receives only over-the-air broadcasts, such as “rabbit ears” or a roof-mounted antenna, choose “Indoor/outdoor ant.”

After you have selected, press the ENTER button.

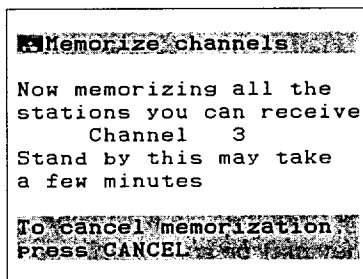

- 6 If you choose “Cable” or “Indoor/outdoor,” an on-screen message and the display on the front of your VCR will show you that the VCR is memorizing the stations you can receive. You can cancel the memorization at any time by pressing CANCEL on the remote control. After the VCR has programmed all the channels, the screen will return the VCR’s picture.

▷ **Important:** Automatic programming may include vacant channels if there are stray signals or noise on those channels. If this occurs, you can manually delete the channels using the procedure in the section “Adding and deleting channels.”

**If you choose “Cable box only,”**

You need to tell the VCR which manufacturer makes your cable box, and on which channel the cable box sends a signal.

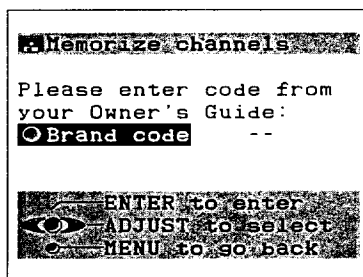

- 7 You will see the screen as shown to the left. The word “Brand code” will be highlighted. Press the ADJUST buttons or the number buttons to select the manufacturer’s code number for your cable box. The codes are listed on the next page:



Manufacturer	Code Number	Manufacturer	Code Number	Manufacturer	Code Number
ABC	1, 2, 11	Magnavox	59, 61, 67	Sheritech	57
Archer	29, 58, 65	Movietime	30, 31, 51, 54	SL Marx	5, 14, 29
Century	29, 65	NSC	20, 51, 52	Sprucer	14, 21, 25
Citizen	29, 65	OAK	27, 39, 40, 49, 50, 61	Stargate	5, 14, 29, 65
Diamond	54, 58	Panasonic	14, 21, 25	Sylvania	66
Eagle	17, 18, 19, 61, 62, 63	Paragon	6, 7	Teknika	36
Eastern	68	Pioneer	14, 15, 16, 92, 93, 94	Texscan	53, 66
G C Electronic	29, 65	Philips	26, 61, 62, 63, 64	Tocom	1,2,3,4,5,41,42,43,44,69,91
Gemini	5, 60	RCA	14, 21, 25	Toshiba	32, 33, 34
General Electric	35	Realistic	37, 38	Unika	48
General Instrument	1,2,3,4,5,41,42,43,44,69,91	Regal	45, 48	United Cable	2
Hamlin	22, 23, 45, 46, 47	Regency	68	Universal	30, 31, 54, 65
Hitachi	24	Rembrandt	55, 56	Videoway	6, 7
Jerrold	1,2,3,4,5,41,42,43,44,69,91	Samsung	5, 14, 21, 25, 29	Viewstar	17, 18, 19, 61, 62, 63
Macom	28	Scientific Atlanta	10, 11, 12, 13	Zenith	6, 7, 8, 9

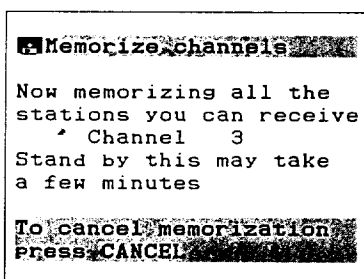
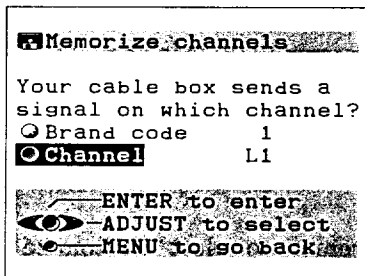
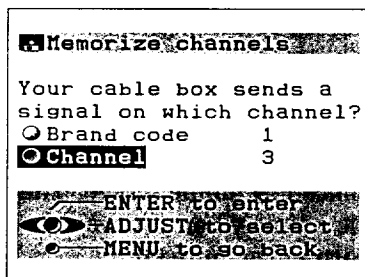

- 8 After you have selected the manufacturer's code, press the ENTER button. The word "Channel" will be highlighted.
- 9 Use the ADJUST buttons to select the channel on which your cable box sends a signal to the VCR. If you connected your cable box with audio/video cables, use the INPUT button to select "L1."
- 10 You need to determine whether or not you have selected the correct "Brand code." To do this, press the CHANNEL buttons on the remote control. As you press the buttons, the channel number on the front of your VCR should change. Watch your cable box. Your cable box should show the exact same number a moment after it appears on your VCR.
  - If your cable box does not change channels at all, or does not show the exact same number, do one of the following:
    - Try moving the cable box on top of the VCR.
    - If more than one "Brand code" is listed for your type of cable box, try a different one. (You can use the CANCEL button to move back to the "Brand code" option.)
- 11 After you have determined that you are using the correct Brand code, press the ENTER button to begin memorizing channels. The TV screen will show you a message that the VCR is memorizing the channels coming from your cable box. Your TV screen, the front of your VCR, and your cable box should all display each channel number, one by one.

When the VCR is finished memorizing, it will return to the VCR's picture.

► **Important:** If no code number is listed for your cable box, or if none of the numbers listed will work, try each code, from 01 to 94.

If your cable box cannot be operated by a remote control (i.e., if it is operated with a mechanical dial or slide), then your VCR will not be able to change channels on the cable box.

If your cable box will not respond to any of the codes, your VCR

cannot change channels on the cable box. You will need to change channels yourself, using the cable box's remote control. You should re-program your VCR, choosing "Cable" in step 5 on page 30. When programming to record, you will need to leave your cable box ON and tuned to the channel you wish to record.

If you connected a satellite receiver, press the CHANNEL Number buttons to see that the TV shows the channels coming from the receiver. If it does not, try repositioning or moving the satellite receiver.

- ▷ **Important:** Automatic programming may include vacant channels if there are stray signals or noise on those channels. If this occurs, you can manually delete the channels using the procedure in the section "Adding and deleting channels."

### Using video mute

When you turn video mute ON, any blank section of tape, or any station with a weak signal, will be replaced by a blue screen. The sound will also be turned off. If there is a time when you would like to try to tune in a weak station, turn video mute OFF.

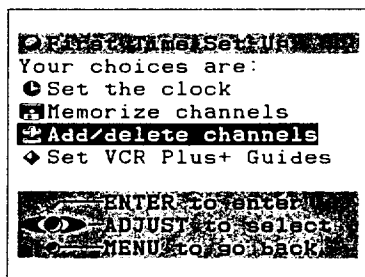
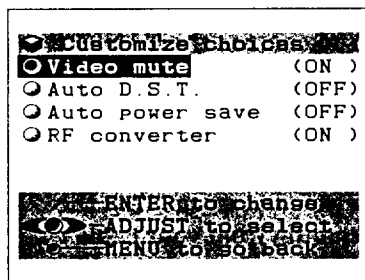
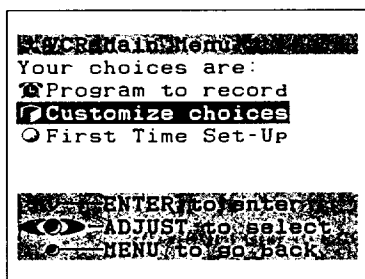

Before you begin, you should know how:

- to view the picture coming from your VCR; (see page 23)
- to use the menus. (See page 26.)

- 1 Press the MENU button on the remote control. The "VCR Main Menu" appears on your TV.
- 2 Use the ADJUST buttons on the remote to select "Customize choices." Press the ENTER button.
- 3 The "Customize choices" menu appears on your screen. Use the ADJUST buttons to select "Video mute." Then, press the ENTER button to set video mute to ON or OFF.
- 4 Press the MENU button once to return to the "VCR Main Menu" menu; press the MENU button a second time to turn off the menus.

### Adding and deleting channels

If necessary, you can manually add or delete channels after you have completed the automatic channel programming. (You cannot do this for channels coming from a satellite receiver.)

Before you begin, you should know how:

- to view the picture coming from your VCR; (see page 23)
- to use the menus. (See page 26.)

- 1 Make sure that video mute is ON. (See above.)
- 2 Press the MENU button on the remote control. The "VCR

Main Menu” appears on your TV.

- ③ Press the ADJUST buttons on the remote control to select “First Time Set-Up.” Press the ENTER button.
- ④ You will see the “First Time Set-Up” menu. Press the ADJUST buttons to select “Add/delete channels.” Press the ENTER button.

▷ **Important:** If you are recording or playing back a tape, or if you are watching a channel from a satellite receiver, then the words “Not available” will flash.

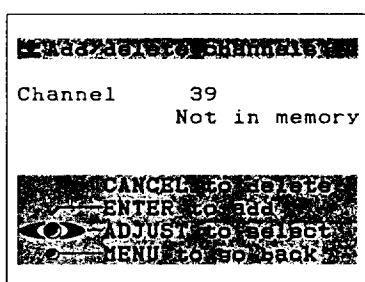

- ⑤ You will see the screen for adding or deleting channels. Use the ADJUST buttons to select the channel that you want to add or delete. Press the ENTER button to add the channel; press the CANCEL button to delete it.
- ⑥ When you are finished adding or deleting channels, press the MENU button once to return to the “First Time Set-Up” menu; press the MENU button a second time to return to the “VCR Main Menu”; press the MENU button a third time to turn off the menu.

▷ **Important:** If you use automatic programming again, you will lose all of the manual changes you made. All of the channels you deleted will be added; all of the channels you added will be deleted. If you are using a cable box that receives only one or two digit channels, you cannot add a three-digit channel.

### Selecting a channel

Now that you have programmed your channels, and added or deleted some, you will want to be able to select channels. (If you have not yet programmed your channels, see page 29.)

▷ **Important:** The VCR can receive Antenna channels 2–69, cable box channels 0–99, or cable channels 1–125. If you try to select a channel number that the VCR cannot receive, the VCR will not change channels. If you are using a satellite receiver, you cannot select cable channels 100–125.

Also, your VCR can receive satellite channels. If you are using an RCA or a Sony receiver, you can select channels 100–999. If you are using a Primestar receiver, you can select 1–999 channels. If you select a channel coming from RCA or Sony receiver, your receiver will automatically turn on.

There are two ways to select channels: sequentially or directly.

#### selecting channels sequentially

Press the CHANNEL buttons on the remote control or on the VCR front panel. This will cycle through the channels in sequential numerical order. (If you have connected your VCR to a satel-

lite receiver, the lowest numbered satellite channel comes after the highest numbered cable or antenna channel.) You can change channels in 10-digit increments by holding down the CHANNEL button for one second when you are using a satellite receiver.

#### **selecting channels directly**

Use the number buttons on the remote control. For example, to choose channel 23, press the “2” button, then the “3” button.

To select a single digit channel, such as channel 5, press the “0” button, then the number button, “5.” You can also press the number button “5,” then press the ENTER button.

To select Primestar channels, such as channel 150, press the INPUT button until the channel number with the Primestar light (◆) appears on the fluorescent display and then press the number button “1”, “5”, “0”.

---

## ◆ Using the Audio and Video Functions

You can select many of the VCR’s audio and video functions and adjust their settings with function menus. You can also choose some advanced features. The VCR will display the functions and settings on the television’s screen. This section will teach you about:

- Descriptions of audio and video functions, and
- Selecting and adjusting the audio and video functions.

The audio and video functions you can select are:

- record speed,
- tape,
- index search, and
- counter zero stop.

### **Descriptions of audio and video functions**

Below are descriptions of the audio and video functions, their uses and their settings. To select these functions and adjust their settings, refer to the section “Selecting and adjusting the audio and video functions.”

#### **recording speed (REC speed)**

The recording speed has an effect on picture quality. SP produces the best picture quality and records up to two hours of video on a T-120 tape. Mitsubishi’s EP speed has only slightly poorer quality, and records up to six hours on a T-120.

The picture may vibrate or the sound may be muted if the recording speed switches when recording.

### tape (Tape)

Adjust this function to ensure the accuracy of the Tape Remaining display. If you are using a tape that is two hours long or less (labeled T-30 through T-120), set this function to "T-120." If you are using a tape labeled T-160, set the function to "T-160." If you are using a tape labeled T-180, set the function to "T-180." If you are using a tape labeled T-210, set the function to "T-210." You cannot use this function with a tape that is less than 30 minutes long.

### index search (Index search)

Index search is a very useful way to find specific points on a tape. (For more information on this feature, please see page 56.)

### counter zero stop (Counter zero stop)

This function is used to automatically fast forward or rewind to "0H00M00s" and stop the tape. (For more information on this feature, please see page 55.)

## Selecting and adjusting the audio and video functions

Below are instructions on how to select and adjust the audio and video functions.

### Before you begin, you need to know:

- how to view the picture coming from your VCR (page 23).

- 1 Press the AUDIO/VIDEO button on the remote control to see the function menu.

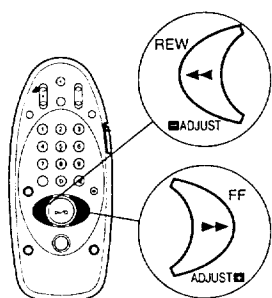
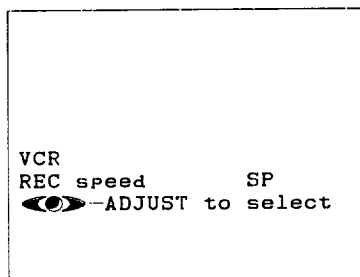
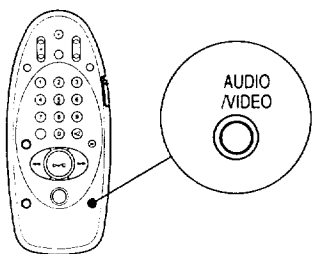

- 2 Press the AUDIO/VIDEO button until the function you want to adjust appears.
- 3 Press the ADJUST buttons on the remote to adjust the setting. The functions will disappear if you do not press any buttons for 5 seconds.

▷ **Important:** The function menu does not appear when the VCR menu is displayed; or during special effects playback. The recording speed (REC speed) and tape functions do not appear during playback.

## ◆ Setting the VCR Plus+ Guide Channel Numbers

The VCR Plus+ system allows you to program your VCR to record television shows by simply entering a PlusCode programming number found after each program in your TV listings.

The VCR Plus+ system assigns a unique number to each channel in your area. You must do a one-time set-up of your VCR using these assigned guide channel numbers in order to record correctly when using the PlusCode numbers. This set-up is required because not everyone receives their channels on the same channel numbers. You simply tell your VCR on which channel number you receive stations.

### A special note to cable box subscribers

*If your local cable company scrambles some or all stations, and/or requires you to use a cable box, then you may need to take an extra step when using the VCR Plus+ system to program your VCR.*

- *If the HS-U270 is able to control your cable box (and you have chosen “Cable box only” when you memorized channels), simply follow the instructions below.*
- *If the HS-U270 is unable to control your cable box (or you have chosen “Cable” when you memorized channels), you will need to set all of the VCR Plus+ Channel Guides to the channel on which your cable box sends a signal (usually channel 3 or 4). Then, when you program, leave your cable box turned ON, tuned to the channel you wish to record.*

*If you have difficulty recording, your cable company may be able to suggest an alternative hook-up method that will allow you to use the VCR Plus+ system without leaving the cable box on, or they may be able to provide additional solutions. Contact them for more help.*

#### Before you begin, you need:

- to know how to view the picture coming from your VCR; (See page 23)
- to know how to use the menus; (See page 26)
- to have completed the “Programming channels automatically” procedure; (See page 29) and
- to correctly set the VCR for your satellite receiver in the “Memorize channels” menu, if you are using. (See page 29)

▷ **Important:** Most importantly, you need to have a list of the VCR Plus+ Channel Guides for your area. This list can be found in *TV Guide*. Your local newspaper or your cable company may also be able to provide you with this list.

#### To set the VCR Plus+ Channel Guides:

Complete the following set-up procedure only for each station whose assigned guide channel number is different from the channel number that you receive it on. For example, if the guide

channel number for NBC is 2, and your VCR receives NBC on 23, you need to “set up” these numbers using the procedure described below.

If all the channels whose numbers are the same (for example, if the guide number for NBC is 2, and your VCR also receives NBC on 2), you can skip this set-up procedure.

Col.1	Channel	Col.2

Col.1	Channel	Col.2
	NBC	23
	ESPN	32
	WPGH	4

Col.1	Channel	Col.2
2	NBC	23
32 ✓	ESPN	32
4 ✓	WPGH	4
33	HBO	112
3	ESPN2	150

Col.1	Channel	Col.2
33	HBO1	112
<del> </del>	<del>HBO2</del>	<del>113</del>
<del> </del>	<del>HBO3</del>	<del>114</del>

- ❶ Locate a list of the VCR Plus+ Channel Guides for your area. This list can be found in *TV Guide*. Your local newspaper or cable company may also be able to provide you with this list.
- ❷ On a piece of paper, prepare a three-column list. Place the headings “Col.1,” and “Col.2” at the top of the list.
- ❸ In the center column, write the name of each channel that you can receive through your antenna or cable system. In the right column, write down the number on which your VCR receives that channel.
- ❹ Using the VCR Plus+ Channel Guide List you obtained in step ❶, write the VCR Plus+ Channel Guide for each channel in the left column. When the numbers in both columns are the same, mark them with a check mark. (Note: the numbers in the illustration are examples only. Refer to your list for the correct numbers.)

If you are using a satellite receiver, write the name of each channel that you can receive through your receiver. In column 2, write down the number on which your receiver receives the channel. If your satellite system receives more than one version of the same channel (for example, HBO1, HBO2, etc.), check the time schedules in your local listings to see which version being listed. You can only set up the particular version that is listed. In your chart, draw a line through the other versions.

- ❺ Press the MENU button on the remote control. Press the ADJUST buttons to select “First Time Set-Up.” Press the ENTER button.
- ❻ The “First Time Set-Up” menu appears on your screen. Press the ADJUST buttons to select “Set VCR Plus+ Guides.” Press the ENTER button.
- ❼ You will see the “Set VCR Plus+ Guides” menu on your screen. In the “Plus Guide” column on the left is a list of the VCR Plus+ guide channel numbers (from column 1 of your worksheet), and in the “BOX Channel” or “VCR Channel” column on the right is a list of the actual channels your VCR receives in your home (from column 2 of your worksheet). Beginning with number 001, check the number in the left column of the VCR menu against the left column of your list.

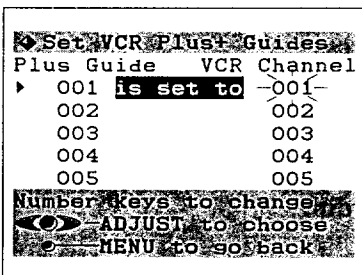
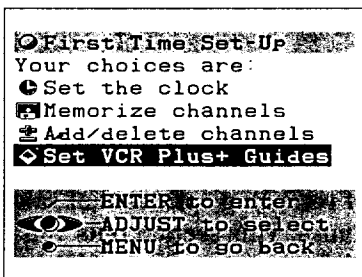

VCR Plus+ Guide	
Plus Guide	VCR Channel
001	001
▶ 002	is set to 002
003	003
004	004
005	005
006	006

VCR Plus+ Guide	
Plus Guide	VCR Channel
001	001
▶ 002	is set to 023
003	003
004	004
005	005
006	006

VCR Plus+ Guide	
Plus Guide	VCR Channel
031	031
032	032
▶ 033	is set to 036
034	034
035	035
036	036

- 8 If the number does not appear in the left column of your list, press the ADJUST buttons to move the cursor to the next number.
- 9 If you find the number in the left column of your list, press the ADJUST buttons to place the cursor next to a VCR Plus+ guide number for the channel. For example, if you want to set NBC, and if the VCR Plus+ guide channel number for NBC is "2," move the cursor next to "2." You may have to cycle through a number of "screens" before the higher number guide channels are displayed on the screen.
- 10 Use the number buttons to enter the actual VCR channel on which you receive the station. For example, if your VCR receives NBC on channel 23, enter the number "23" next to the VCR Plus+ guide channel for NBC.
  - For DSS® channels simply enter the three digit number. (The letter "S" will display next to the channel number.)
  - If you are using a PRIMESTAR® receiver, press the INPUT button and then press the number buttons to select PRIMESTAR channels. (The letter "S" will display next to the channel number.)
  - If you are using a cable box that the VCR cannot control, enter the channel on which your cable box sends signals to your VCR (usually channel 3 or 4).
- 11 Repeat steps above for all numbers in the left column of the VCR menu. If the numbers in the left and right columns of your chart are the same (indicated by a check mark), leave them the same in the VCR menu.
- 12 When you are finished, press the MENU button three times to exit the menus. Your VCR can now use the PlusCode numbers in your local listings to record shows from an antenna, a cable system, or a satellite receiver.

## ◆ Recording

Your new VCR offers a wide variety of recording options that take full advantage of our advanced electronics. This section tells you about the following recording procedures:

- Recording a current broadcast,
- Programming your VCR to record,
- Cancelling a recording in progress,
- Programming with the VCR Plus+ system,
- Using One-Touch Recording (OTR),
- Using One Key Programming,
- Using Quick Program, and
- Notes about programmed recording.



## Recording a current broadcast

### Before you begin, you need to know how:

- to view the picture coming from your VCR. (See page 23.)

To record a TV program that is currently playing:

- ❶ Load a tape with its erasure tab intact into the VCR.
- ❷ If you have not already done so, set the speed at which you would like to record. (See “Selecting and adjusting the audio and video functions” on page 35.)
- ❸ Set the VCR’s input to tuner. To do this, press the INPUT button on the remote until the channel number shows on-screen or on the front panel display. (If you would like to record channels from a Primestar receiver, press the INPUT button until the channel number with the Primestar light appears on the front panel display.)
- ❹ Select the channel you would like to record by using the CHANNEL button or the number buttons. (If you are using a cable box that the VCR cannot control, select channel 3 or 4 on the VCR, and change the channel on the cable box, not on the VCR.)
- ❺ Press the record button (REC) on the remote control or the record button (REC/OTR) on the front panel of the VCR.

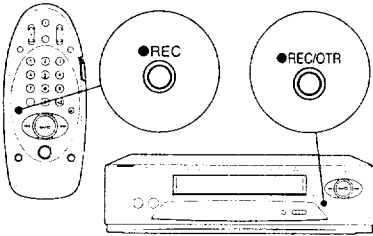

Recording will start. When you reach the end of the tape, the VCR will automatically rewind. You can stop recording at any time by pressing the PLAY/STOP or PAUSE button on the remote or the PLAY/STOP button on the front panel. To resume recording from STOP, press the REC or REC/OTR button. To resume recording from PAUSE, press the PAUSE button. (You cannot use the REC/OTR button to resume recording from PAUSE.)

▷ **Important:** If you pause the VCR for five minutes, recording will stop automatically to protect the tape. If you record in extended play (EP), you will only be able to play the tape on a VCR equipped for EP play, such as this one. If you attempt to record on a tape that has had its erasure prevention tab removed, the VCR will eject the tape.

## Programming your VCR to record

You can program your VCR to record with the help of Mitsubishi’s on-screen operating system. You can schedule up to eight recording “events” within a one month period.

### Before you begin, you must:

- know how to view the picture coming from your VCR; (See page 23) and
- have set the clock. (See page 27)

To program your VCR to record:

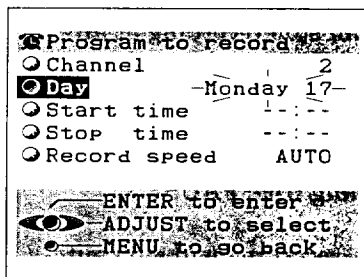
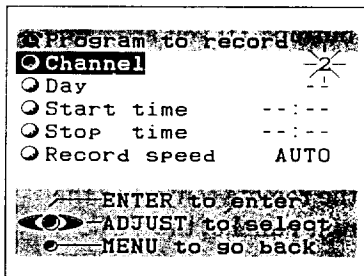
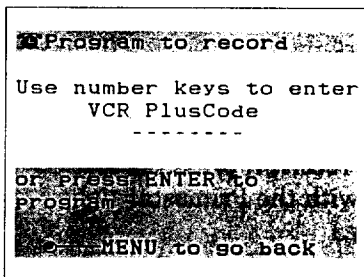
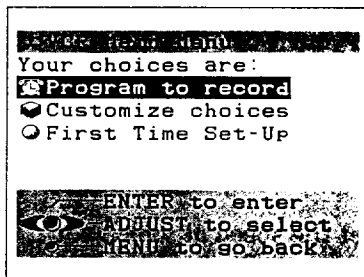

► **Important:** When selecting a day, your choices are: a single day up to one month away, every day from Monday through Friday, or the same day every week. To program for every day from Monday through Friday (to tape a soap opera, for example), press the ADJUST buttons until “Monday-Friday” appears. To program the same day every week (to tape your favorite weekly sitcom, for example), press the ADJUST buttons until “Every” and the desired day of the week appear.

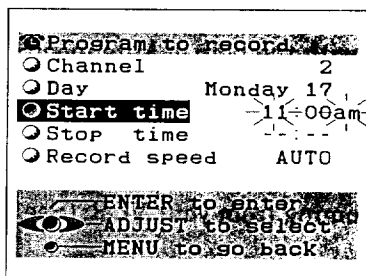

- 1 Load a tape with its erasure tab intact into the VCR.
- 2 Press the MENU button on the remote control. The “VCR Main Menu” appears on your screen. Use the ADJUST buttons on the remote control to select “Program to record.” Press the ENTER button.

If there is at least one programmed recording already entered, you will see the “recap” screen. You can choose an empty recording slot, or wait four seconds and the VCR will automatically choose the first empty slot.

- 3 You will see the VCR Plus+ “Program to record” menu. (For more information on using the VCR Plus+ system to program your VCR, see page 42.) Press the ENTER button to skip this screen.
- 4 You will see the “Program to record” menu. Press the ADJUST buttons to choose the channel you would like to record (for example, channel 2). Press the ENTER button.
  - If you are using a cable box that the VCR cannot control, enter the channel number on which the cable box sends a signal to your VCR (usually channel 3 or 4).
  - If you wish to record from an external source, press the INPUT button or the ADJUST buttons until “External” appears.
  - If you are recording from a satellite receiver, you do not need to select “L.” Simply choose the channel you would like to record (for example, channel 245.) The word “SAT” will display next to the channel number.
- 5 The “Day” will flash. Press the ADJUST buttons to choose the day on which you want to record (for example, Monday the seventeenth). Press the ENTER button.

- 6 The hour numbers of the starting time, along with the am/pm indicator, will flash. Press the ADJUST buttons to set the hour when you wish recording to start. Press the ENTER button.

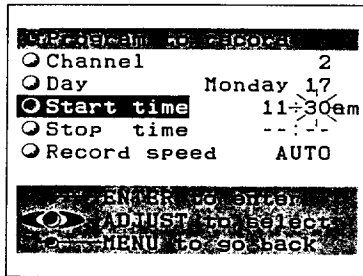

- 7 The minute numbers of the start time will flash. Press the ADJUST buttons to set the minutes when you wish recording to start. Press the ENTER button.

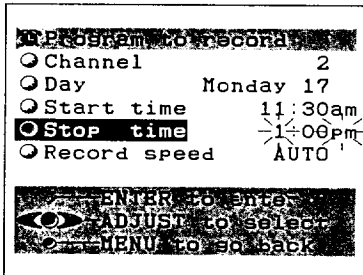

- 8 The hour numbers of the stop time, along with the am/pm indicator, will flash. Press the ADJUST buttons to set the hour when you wish recording to stop. Press the ENTER button.

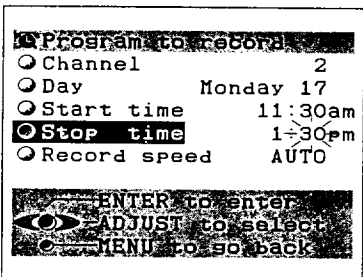

- 9 The minute numbers of the stop time will flash. Press the ADJUST buttons to set the minutes when you wish recording to stop. Press the ENTER button.

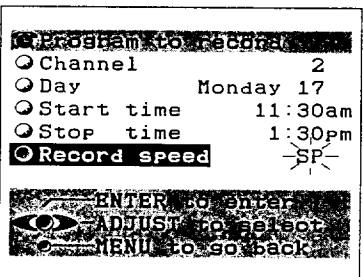

- 10 Press the ADJUST buttons to set the recording speed (SP, EP, or auto recording speed (AUTO)). (See "auto speed programming" on page 48 for an explanation of the auto speed recording feature.) Press the ENTER button.

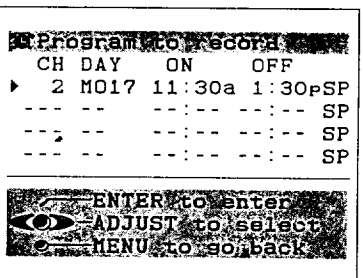

- 11 The contents of the programmed memory will appear on the "recap" screen. The letter "S" will be displayed next to the satellite channel.

- 12 To program additional recording times, select an empty program line by pressing the ADJUST buttons. Then, press the ENTER button. You will return to the VCR Plus+ "Program to record" screen. Continue the programming procedure from step 3.

▷ **Important:** Only four of the eight program lines appear on-screen at any one time. To see additional program lines, press the ADJUST buttons to scroll the lines on the screen.

- 13 When you are finished with all programming, turn the VCR power OFF and make sure the programmed recording light is lit. However, if you have a cable box or a PRIMESTAR® receiver, leave it turned ON. Additionally, if the HS-U270 does not control your cable box, leave the box tuned to the station you wish to record.

### changing settings while programming

If you wish to change one of your settings (such as start time) while you are programming, press the ENTER and CANCEL button on the remote to select the setting you wish to change. ENTER will move you forward through the list, while CANCEL will move you backwards. Then, use the ADJUST buttons to change the setting.

▷ **Important:** If you press the CANCEL button while the channel number is flashing, you will cancel the entire program.

### Cancelling a recording in progress

There are two ways to cancel a recording in progress.

1. Press the PLAY/STOP button. The recording is stopped, but the program is not cancelled. Therefore, if you press the REC or REC/OTR button, the recording will start again.
2. Press the POWER button on the front panel. The recording is stopped and the program is cancelled.

### Programming with the VCR Plus+ system

The VCR Plus+ system allows you to program your VCR to record by simply entering a PlusCode programming number. You can find this number in *TV Guide* or (possibly) your local TV listings.

#### Before you begin,

- you need to know how to view the picture coming from your VCR; (see page 23)
- you must have set the clock; (see page 27) and
- you must have set your VCR Plus+ Channel Guides. (See page 36.)

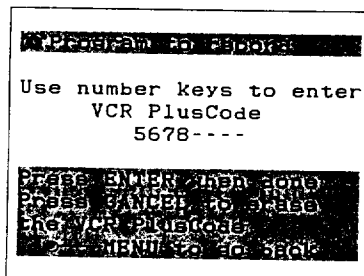
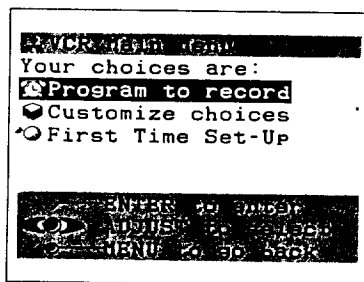

- 1 Load a tape with its erasure tab intact into the VCR.
- 2 Press the MENU button on the remote control. The “VCR Main Menu” appears on your screen. Use the ADJUST buttons on the remote control to select “Program to record.” Press the ENTER button.

If there is at least one programmed recording already entered, you will see the “recap” screen. You can choose an empty recording slot, or wait four seconds and the VCR will automatically choose the first empty slot.

- 3 You will see the VCR Plus+ “Program to record” screen. Use the number buttons on the remote control to enter the PlusCode number for the television show you want to record. For example, if the PlusCode number for the program you want to record is 5678, simply enter “5678.”

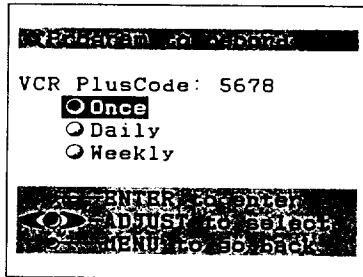

- 4 If you enter a number incorrectly, press the CANCEL button on the remote control. When you have finished entering the PlusCode number, press the ENTER button.
- 5 Use the ADJUST buttons to select whether you want to record your program once, daily, or weekly.
  - If you choose “Once,” your VCR will only record the show once.
  - If you choose “Daily,” your VCR will record the same channel at the same time, Monday through Friday.
  - If you choose “Weekly,” your VCR will record the same channel at the same time, on the same day, each week.

After you have made your choice, press the ENTER button.

▷ **Important:** If two programmed recording times overlap, the message, “VCR is already programmed for that time” will display on the screen. You will need to erase the previous program before you can enter the new one. If the code number you entered is wrong, the message, “VCR PlusCode, Not a valid code” will display on the screen.

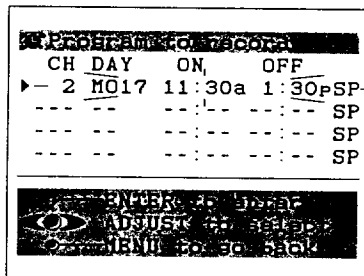

- 6 The program you have chosen to record will appear in the “recap” format, and will flash for three seconds.
- 7 If you wish to change the record speed, press the ENTER button repeatedly until the record speed is flashing. Change the recording speed by pressing the ADJUST buttons. When finished, press the ENTER button once more.
- 8 To program additional recording times, select an empty program line by pressing the ADJUST buttons. Then, press the ENTER button. You will return to the VCR Plus+ “Program to record” screen. Continue the VCR Plus+ programming procedure from step 3.
- 9 When you are finished with all programming, turn the VCR power OFF and make sure the programmed recording light is lit. However, if you have a cable box or a PRIMESTAR® receiver, leave it turned ON. Additionally, if the HS-U270 does not control your cable box, leave the box tuned to the station you wish to record. If you want to cancel the programmed recording after it started, press the POWER button on the front panel.

### Using One-Touch Recording (OTR)

One-Touch Recording (also called OTR) is a way to begin recording immediately, but have your VCR stop recording and turn off automatically after your show is over.

Before you begin, you need to know how:

- to view the picture coming from your VCR. (See page 23.)
- 1 Load a tape with its erasure tab intact into the VCR.

- 2 If you have not already done so, set the speed at which you would like to record. (See “Selecting and adjusting the audio and video functions” on page 35.)
- 3 Set the VCR’s input to tuner. To do this, press the INPUT button on the remote until the channel number shows on-screen or on the front panel display. (If you would like to record channels from a Primestar receiver, press the INPUT button until the channel number with the Primestar light appears on the front panel display.)
- 4 Use the CHANNEL buttons or the number buttons to select the channel you would like to record.

If you are using a cable box that the VCR does not control, select channel 3 or 4 on the VCR, and change the channel on the cable box.

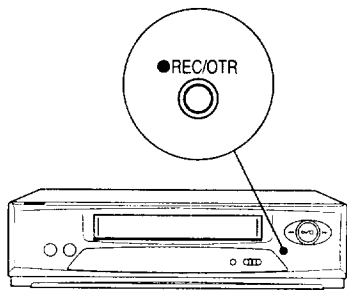

- 5 Press the REC/OTR button on the front panel twice. The first time you press the button, recording will begin. The second time you press the button, 30 minutes is added to the OTR timer, which is displayed on the front panel.
- 6 Press the REC/OTR button for each 30 minutes you want to add to the OTR timer, up to 4 hours. If you press the button 10 times, you will see the word “End” on the front panel display. The VCR will record until the end of the tape. If you press the button an eleventh time, the VCR will resume normal recording.

The OTR timer will begin to count down. When it reaches zero, the VCR will stop recording and turn off. If you have previously programmed your VCR to record, the VCR will be ready to record what you’ve programmed. If the end of the tape is reached before OTR is finished, the VCR will stop and the power will turn off.

▷ **Important:** If you attempt to record on a tape that has had its erasure prevention tab removed, the VCR will eject the tape.

**If you program too much time into the OTR timer,** continue pressing the REC/OTR button. You will “cycle” around once you have reached the 4-hour point. You can start over, adding time in 30 minute intervals.

#### how OTR affects other controls

If you press the PAUSE button during OTR, the VCR will pause recording, but the OTR timer continues to count down.

If you press the PLAY/STOP button during OTR, you erase the OTR programming.

You cannot use the REC/OTR button on the front panel to resume recording from the record-pause mode.

## Using One Key Programming

One Key Programming is a programming method that is simple to use and easy to learn, without using the remote control.

Before you begin,

- you need to know how to view the picture coming from your VCR; (see page 23) and
- you must have set the clock. (See page 27.)

To use One-Key Programming:

- 1 Load a tape with its erasure tab intact into the VCR.
- 2 Press the ONE KEY PROGRAM button. (If you have not set the time, the "Set the clock" menu will appear. Set the clock, and then proceed.) If there is already a program in the VCR's memory, you will see the "recap" screen. You can use the ONE KEY PROGRAM button to select an empty programming slot, or you can wait 4 seconds for the VCR to automatically select an empty slot.
- 3 You will see the "Program to record" screen. Press the ONE KEY PROGRAM button until the channel you would like to record (for example, channel 2) appears. Then, wait for 4 seconds. The "Day" will be highlighted. (If you are recording from a cable box that the VCR cannot control, set the channel to 3 or 4, whichever the cable box sends signals on.)

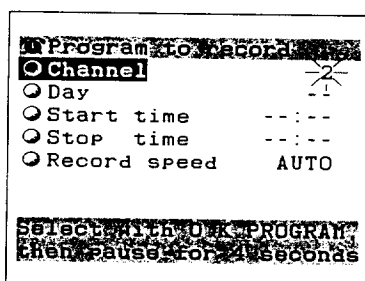

▷ **Important:** If you wish to record from an external source, press the ONE KEY PROGRAM button until "External" appears.

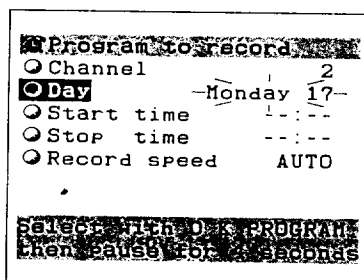

- 4 Press the ONE KEY PROGRAM button to choose the day you would like to record (for example, Monday the seventeenth). Then, wait for 4 seconds. The hours of the starting time will flash.

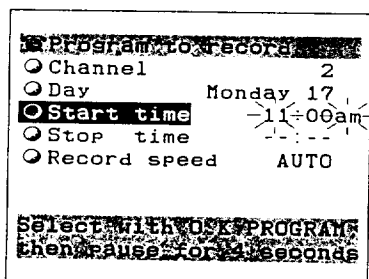

- 5 Press the ONE KEY PROGRAM button to choose the hour when you wish recording to start. Then, wait for 4 seconds. The minute numbers will begin to flash.

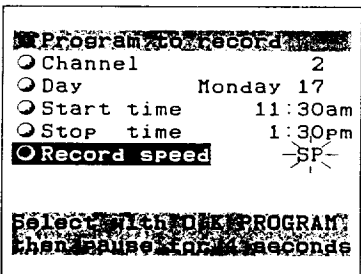
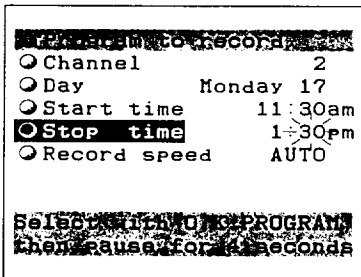
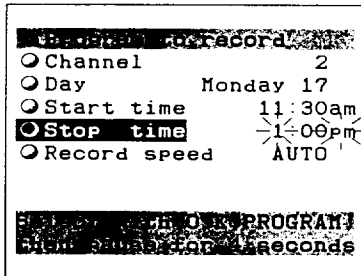
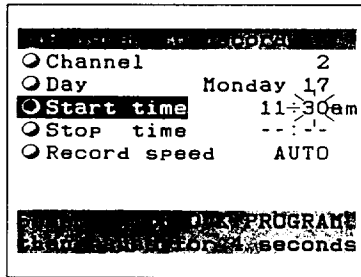

- 6 Press the ONE KEY PROGRAM button to choose the minute when you wish recording to start. Then, wait for 4 seconds. The word "Stop time" is highlighted.
- 7 Press the ONE KEY PROGRAM button to choose the hour when you wish recording to stop. Then, wait for 4 seconds. The minute numbers will begin to flash.
- 8 Press the ONE KEY PROGRAM button to choose the minute when you wish recording to stop. Then, wait for 4 seconds. The record speed will flash.
- 9 Press the ONE KEY PROGRAM button to set the recording speed. After 4 seconds, the menus will turn off.
- 10 When you are finished with all programming, turn the VCR power OFF and make sure the programmed recording light is lit. However, if you have a cable box, or a PRIMESTAR® receiver leave it turned ON. Additionally, if the HS-U270 does not control your cable box, leave the box tuned to the station you wish to record.

The VCR is ready to record what you've programmed.

#### changing settings while programming

If you make a mistake when using One Key Program:

- 1 Press the FF or REW buttons on the front panel to select the setting you wish to change. Pressing the FF button will move you forward, while pressing the REW button will move you backward. If you wish to use the remote control, you can use ENTER to move forward or CANCEL to move backward.
- 2 Once you have chosen a setting, you can change it by using the PLAY/STOP button on the front panel or the ADJUST buttons on the remote control.
- 3 Once you have corrected the setting, press the FF button or press the ENTER button to resume your place.

▷ **Important:** If you press CANCEL or REW while the channel number is flashing, you will cancel the entire program. If you want to stop using One Key Programming before completing the programming, press the MENU button on the remote control.



## Using Quick Program

Quick Program is an exclusive Mitsubishi feature that simplifies the process of programming your VCR to record. When you press the QUICK PROGRAM/VCR Plus+ button on the remote control, you will immediately see the VCR Plus+ "Program to record" menu and can begin programming right away.

You can use this feature even when the VCR is stopped, playing, recording, fast forwarding, rewinding, or off. However, the QUICK PROGRAM/VCR Plus+ button does not function during One Key Programming.

To use quick program:

- 1 Press the QUICK PROGRAM/VCR Plus+ button on the remote control. If the VCR is off, it will turn on. After tuning your TV to the correct channel or input, you will see the VCR Plus+ "Program to record" screen.

If the VCR's memory is full, you will see the recap screen (left) instead of the VCR Plus+ "Program to record" screen. You will need to use the CANCEL button to erase an entry before you can add another one.

- 2 Complete programming as described in "Programming your VCR to record," or "Programming with the VCR Plus+ system." When you are finished, press the QUICK PROGRAM/VCR Plus+ button again. If the VCR is stopped, it will turn off and be ready to record your program at a later time. If the VCR is playing, recording, fast forwarding or rewinding, the menus will turn off, but the VCR power will remain on.

When you are finished with all programming, be sure the VCR power is OFF and the programmed recording light is lit. However, if you have a cable box or a PRIMESTAR® receiver, leave it turned ON. Additionally, if the HS-U270 does not control your cable box, leave the box tuned to the station you wish to record.

- ▷ **Important:** If you press the QUICK PROGRAM/VCR Plus+ button, but the clock is not set, you will see the "Set the clock" menu.

### Notes about programmed recording

- ▷ **Important:** You cannot use the VCR when the programmed recording light is lit. If you want to use the VCR before programmed recording begins, press the POWER button on the remote once. This turns the programmed recording light off and the VCR on.

If you use the POWER button on the front panel for this purpose, you will have to press it twice. Pressing it once turns off the programmed recording light; pressing it a second time turns the VCR on.

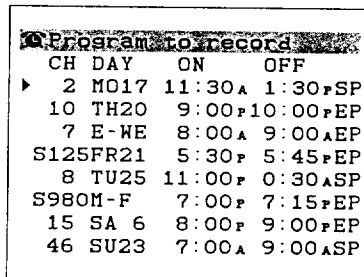
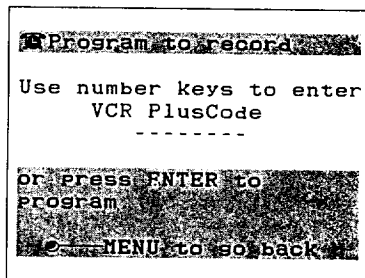

CH	DAY	ON	OFF
▶ 2	MO17	11:30A	1:30P SP
10	TH20	9:00P	10:00P EP
7	E-WE	8:00A	9:00A EP
S125FR21		5:30P	5:45P EP
8	TU25	11:00P	0:30A SP
S980M-F		7:00P	7:15P EP
15	SA 6	8:00P	9:00P EP
46	SU23	7:00A	9:00A SP

When you are finished using the VCR, turn the VCR power off again, either with the POWER button on the remote or the POWER button on the front panel. Make sure the programmed recording light is back on.

After a program has been recorded, the VCR memory is cleared (unless you have scheduled the VCR to record the program every day or every week).

If there is already a program in the VCR's memory, you will see the "recap" screen when you bring up the menus for programming to record (unless you are programming with the QUICK PROGRAM/VCR Plus+ button). If the VCR's memory is full, you must erase a program before you can enter a new one.

If a tape runs out during programmed recording, the VCR ejects the tape and the programmed recording light and the tape status symbol will flash. Load a new tape and press the REC button. The VCR will resume recording. Do not overlap the recording times you program.

▷ **Important:** Remember that when your VCR is off, it may also be in stand-by for programmed recording. Also remember that the VCR, when programmed, will record over the next section of tape. So, to avoid recording over tapes you want to save, remember that the VCR automatically shuts off during OTR recording and auto power saving.

Your VCR will not record over a tape that has the erasure prevention tab removed (see "Preventing accidental erasure"). All rental movies have this tab removed, so they are safe from being accidentally erased.

#### auto speed programming

Use auto speed programming if you want to record as much of the program as possible in standard play (SP) speed, but you want the VCR to automatically switch to extended play (EP) if there is not enough tape left.

Auto speed programming is only available in one programming slot. In the first slot, the recording speed is automatically set to AUTO. If you want to use auto speed programming in this programming slot, you don't need to change anything.

▷ **Important:** Make sure that the "Tape" video function matches the kind of tape you are using. (See "Selecting and adjusting the audio and video functions" on page 35.)

Set the time for recording to end a minute or two beyond the program's scheduled broadcast time.

While using auto speed programming, the picture may vibrate or the sound may be muted when the recording speed switches to extended play (EP).

### programming TV programs that end on the day after

If you want to start the recording at 11:00 PM and end it at 2:00 AM the next day, simply set the start time to 11:00 PM on the recording start day and the end time to 2:00 AM. There is no need to change the day of the week.

### skipping programs

If you have already entered a program into your VCR's memory, you can skip the program without going into the VCR's menus. Simply press the POWER button on the front panel once. The programmed recording light will turn off, and the program will be skipped. If you decide not to skip the program, press the POWER button on the front panel twice; the programmed recording light will light up again.

### changing programmed recording settings

If you want to change the programmed recording settings:

- 1 Press the MENU button on the remote control. Your VCR will turn on and the "VCR Main Menu" will appear on your screen.
- 2 Press the ADJUST buttons to select "Program to record." Press the ENTER button. You'll see the "recap" screen.
- 3 Press the ADJUST buttons to place the cursor next to the program you wish to change. Press the ENTER button. You will see the "Program to record" menu.
- 4 Repeatedly press the ENTER button to select the item you wish to change. Use the ADJUST buttons to change it.
- 5 Use the MENU button to turn off the menus. Then, use the POWER button to turn off the VCR. Make sure the programmed recording light is on.

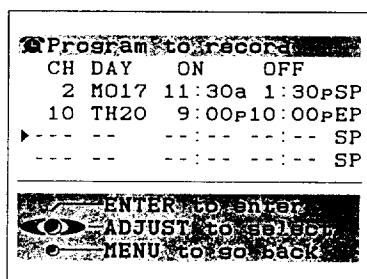

### canceling a programmed recording

- 1 Press the MENU button on the remote control. Your VCR will turn on and the "VCR Main Menu" appears on your screen. Use the ADJUST buttons on the remote control to select "Program to record." Press the ENTER button.
- 2 You will see the "recap" screen. Use the ADJUST buttons to place the cursor next to the program you wish to cancel.
- 3 Press the CANCEL button. The program is erased.
- 4 Press the MENU button once to return to the VCR Main Menu; press it again to turn off the menus.

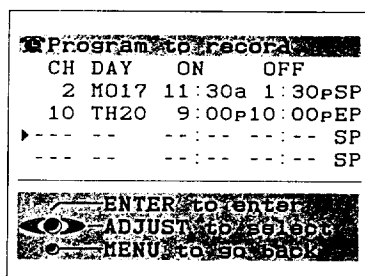

**loading a tape for programming**

If, after programming, you forget to load a tape, or if you load a tape with its erasure tab removed, then the programmed recording light and the tape status symbol will flash. A tape without an erasure tab will be ejected. To correct this, load a tape with its erasure tab intact, and turn off the VCR.

**using the satellite receiver**

If you are using a RCA or Sony satellite receiver, your VCR can automatically turn the receiver on and off when it is time for a programmed recording. However, if you are using a PRIMESTAR® receiver, you will have to turn the receiver on before the programmed recording begins.

Before turning off the VCR to put your VCR in stand-by for recording, make sure that the satellite receiver' menu turns off.

**memory backup**

If the VCR is without power for 30 seconds or less, it will retain the time and the programmed settings, provided the VCR has been plugged in for at least an hour beforehand. If the power is lost for more than 30 seconds, the time and the programmed settings will be lost.



Now that you've learned about the basic operation of your VCR, you're ready to discover its advanced features. You'll find information on:

- ◆ **Using the Advanced Playback Controls**
- ◆ **Displaying the Remaining Time and the Present Time**
- ◆ **Searching Techniques**
- ◆ **Using the Advanced Options**
- ◆ **Making a Copy of a Tape**
- ◆ **Using Child Lock**

Before you use the advanced features, you should be familiar with all of the VCR's basic operations, including viewing a picture coming from your VCR (page 23), playing back a tape (page 25), using the menus (page 26), and recording (page 38). If you find any of the information in this section confusing, you may want to review the previous chapters.

---

## ◆ **Using the Advanced Playback Controls**

In this section, you'll discover some of the advanced playback features of your VCR. These include:

- Using special effects,
- Adjusting the tracking, and
- Using the time counter.

### **Using special effects**

You can use the FF and REW buttons to control the playback speed of the tape in a step-by-step method.

**using the FF and REW buttons to control the playback speed**

- ❶ While the VCR is playing a tape, press the PAUSE button on the remote control to freeze the picture on the screen.
- ❷ Press the FF or REW button. Each press of the FF button changes the playback speed by one step in the forward direction. Each press of the REW button changes the speed by one step in the reverse direction. (See the chart on the next page.)
- ❸ To resume normal playback, press the PLAY/STOP button.

▷ **Important:** After about five minutes in the still or slow-motion mode, the VCR will automatically stop to avoid damage to the tape.

Depending on the type of TV you are using, the picture may vibrate vertically when you pause the VCR's picture.

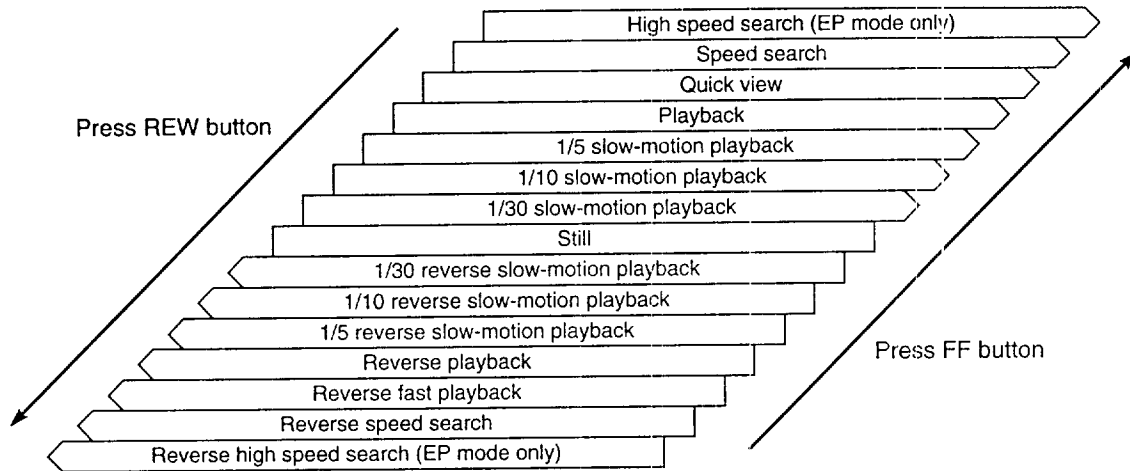

**using still adjustment**

Sometimes during still frame, the picture may vibrate or shake. To correct this problem, press the CHANNEL buttons on the front panel. (Side-to-side vibration cannot be corrected.)

**using two times playback**

You can see the contents of the videotape in double speed playback. While the VCR is playing a tape, press the INPUT button on the remote control. You'll see the picture in double speed playback. A certain amount of "noise" in the picture is normal. To resume normal playback, press the PLAY/STOP button.

**Adjusting the tracking**

**automatic tracking**

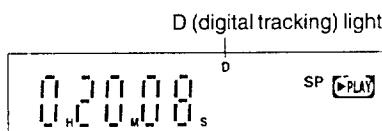

Your VCR automatically adjusts the tape to give you the best quality picture. When you press the PLAY/STOP button, the DIGITAL TRACKING light (D) will flash, showing that the VCR is adjusting the picture. When the VCR has finished adjusting the picture, the DIGITAL TRACKING light will shine steadily.

▶ **Important:** A certain amount of "noise" in the picture is normal while the VCR is tracking a tape.

**manual tracking**

From time to time, you might play a tape that has excess "noise" in the picture (often looking like vibration or interference at the top or bottom of the screen). To correct the picture, you will have to manually track the tape.

- ❶ While the tape is playing, press the CHANNEL buttons on the front panel until the picture is clear of excess "noise."
- ❷ To continue automatic tracking, press both front panel CHANNEL buttons at the same time. Automatic tracking will also resume when you eject the tape.

### slow tracking

Slow tracking is used to adjust the playback quality during slow motion playback and still frame. You can only use slow tracking if your tape was recorded in extended play (EP) speed. To adjust the slow tracking, put a tape into slow motion, then press the CHANNEL buttons on the front panel of the VCR until the best picture is obtained.

### Using the time counter

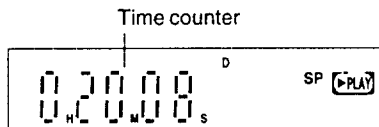

Your VCR has a time counter that shows the amount of time the tape has run in hours, minutes, and seconds. This counter is useful when you want to find specific points on a tape. The counter will not work with blank tapes, on blank sections of tape, or when the VCR's power is off.

### setting the counter

To set the counter to "0h00m00s," press the CANCEL button on the remote control. (You cannot reset the counter if the VCR channel number is being displayed on the TV or if you are using the VCR's menus.)

Your VCR will automatically reset the counter to "0h00m00s" when you load a tape into the VCR. It will display "- h - - m - - s" when there is no tape in the VCR.

## ◆ Displaying the Remaining Time and the Present Time

This sections explains displaying the remaining time and present time.

### Displaying the time gauge and the remaining time

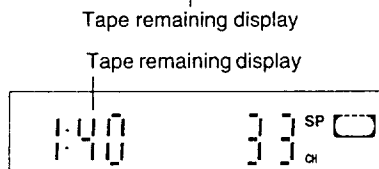
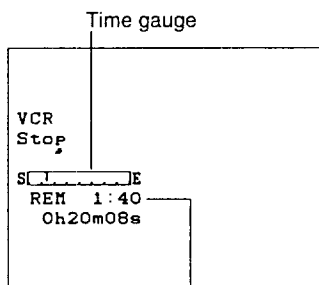

The time gauge is a graphic representation of your position on a video tape. The left side of the gauge is the start (S) of the tape, and the right side is the end (E) of the tape. For a T-120 length tape, played at standard (SP) speed, each mark on the gauge represents about 15 minutes. The remaining time display shows the time, in hours and minutes, left until the end of a tape.

**The time gauge and the remaining time automatically appear:** during fast forward and rewind (from a stopped tape), during index searches, and counter zero stop.

You can turn off the time gauge and the remaining time by pressing the DISPLAY button twice.

**To make the time gauge and the remaining time appear:**

Press the DISPLAY button once. The time gauge and remaining time will appear on the TV screen, and the remaining time will appear on the fluorescent display. They will disappear after four seconds when playing a tape. To turn off the display, press the DISPLAY button twice.

- ▷ **Important:** The time gauge and remaining time work by detecting control signals on recorded tapes. They will therefore not function with tapes that have not yet been recorded. Also, you must have set the “Tape” video function correctly.

Depending on the length of the tape being used, it may take a moment for the display to appear.

The tape remaining display may not show the correct remaining time if the tape function is incorrectly set (see “Using the Audio and Video Functions” on page 34), if you are using speed search, if you are using a special length cassette (such as T-10 length), or if you are using a cassette with an adapter.

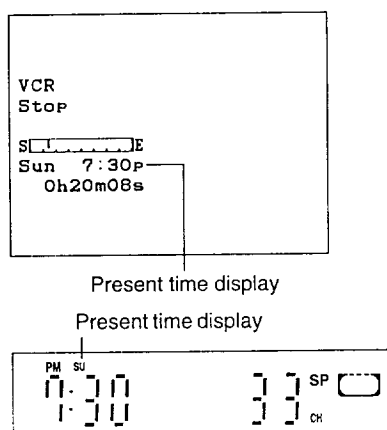

### Displaying the present time

The present time display on the fluorescent display panel or on the TV screen shows the current time. If you have not set the clock, or if there has been a power failure of longer than 30 seconds, the display will show - : -. The current time will be displayed when the VCR is off. To see the current time when the VCR is on:

- ① Press the DISPLAY button on the remote control twice. The counter will be replaced by the present time.
- ② To turn off the present time, press DISPLAY once.

## ◆ Searching Techniques

The VCR lets you search through a tape in a number of ways. These include:

- Quick searching,
- Speed searching,
- Using counter zero stop, and
- Index search techniques.

### Quick searching

This feature lets you skip over the tape you are playing in about 30 second intervals. It is designed so that you can quickly speed through any commercials you may have recorded. To do this:

- ① Make sure that you have set the TV/VCR slide switch on the remote control to the “VCR” position.
- ② While playing a tape, choose the desired search time by pressing the number button. (See the chart on the next page.) The VCR will speed through the selected length of tape, then resume playback.



Number button	1	2	3	4	5	6
Search time	30 sec.	60 sec.	90 sec.	120 sec.	150 sec.	180 sec.

You can set the search time up to 3 minutes.

### Speed searching

You can use speed search to visually search through the contents of a videotape. To do this:

- ➊ While playing a tape, press the FF or REW button. You will see the picture as it fast forwards or rewinds. It is normal to see some “noise bars.”
- ➋ If you are playing back a tape recorded in extended (EP) speed, press the FF or REW button and hold it down for about 1 second. The search speed will increase. (In case of a tape recorded in standard (SP), the speed will not change.)
- ➌ To resume normal playback, press FF or REW again quickly, or press PLAY/STOP.

▷ **Important:** The fastest search speed that allows you to see the picture is about 15 times normal speed. Using fast forward or rewind without the picture allows you to search up to 200 times normal speed. The fastest way to move through the tape is without a picture. It is normal for the number of noise bars on the screen to increase and roll from top to bottom as the visual search speed increases.

### Using counter zero stop

Counter zero stop is useful to quickly access to the beginning of a recorded or playback section of a tape. The VCR will automatically fast forward or rewind to “0H00M00s” and stop the tape.

- ➊ Press the CANCEL button on the remote control at the point you wish to locate later. The counter will reset to “0H00M00s.”
- ➋ When you wish to return to the point specified in step ➊, press the AUDIO/VIDEO button on the remote control. The function menu appears on your screen. Press the AUDIO/VIDEO button until the counter zero stop function appears.
- ➌ Press the ADJUST + button to start the counter zero stop.

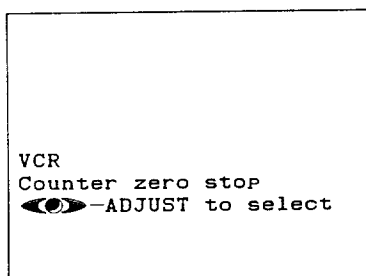

The VCR will automatically search to the counter “0H00M00s” and then stop.

## Index search techniques

Index search is a way to find specific points on a tape. Before using index search, index marks are placed at important places on a tape. Then, index search is used to find these marks. Index marks are added automatically whenever your VCR starts a new recording; you can also add index marks manually at any point during recording.

### automatic index marks

Whenever recording is begun from the STOP mode, an index mark is automatically added to the tape. The on-screen message will indicate that the mark is being recorded.

- ▷ **Important:** Index marks are not added when you press PAUSE to begin recording from the record-pause mode.

### manual index marks

To add an index mark yourself, press the REC button on the remote control while a tape is recording.

- ▷ **Important:** Index marks must be added at least one minute apart.

To search for an index mark:

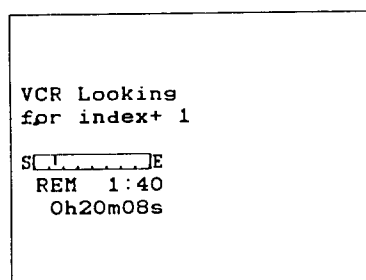
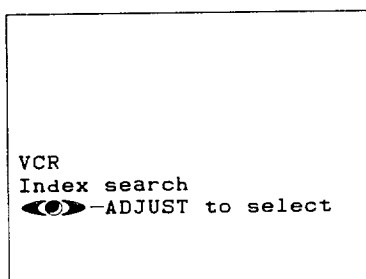

- ❶ Press the AUDIO/VIDEO button on the remote control. The function menu appears on your screen. Press the AUDIO/VIDEO button until the index search function appears.
- ❷ Press the ADJUST + button to start the index search a forward search; press the ADJUST – button to begin a search in the reverse direction. The VCR will fast forward or rewind and index search display (below left) will appear on the TV. Once the VCR finds an index mark, it will begin playing back the tape from that point.
- ❸ You can press the plus (+) or minus (–) buttons up to 19 times to search for that many index marks. For example, to find the third index mark ahead, press the plus (+) button three times. The on-screen display will count down the number of marks to be passed before playback begins.
- ❹ To cancel index search, press PLAY/STOP.

## ◆ Using the Advanced Options

You can make some optional setup choices. This section explains:

- Using the auto daylight saving time,
- Using the auto power saving (auto-off), and
- Setting the RF converter.

## Using the auto daylight saving time

When you set the daylight saving time setting to on, your VCR will automatically adjust the clock for Daylight Saving Time.

▷ **Important:** With the auto daylight saving time is ON, your VCR will automatically change the clock from 2 AM to 3 AM on first Sunday in April, and change from 3 AM back to 2 AM on last Sunday in October. Remember that when you programmed on these days, your recording length may be affected because the VCR clock automatically changes.

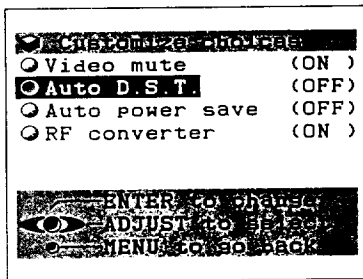
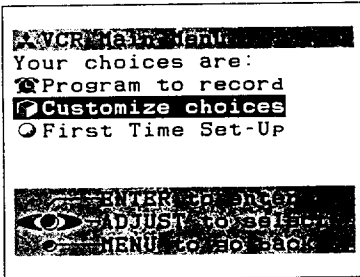

To use the auto daylight saving time:

- 1 Press the MENU button on the remote control. The "VCR Main Menu" appears on your TV.
- 2 Use the ADJUST buttons on the remote to select "Customize choices." Press the ENTER button.
- 3 The "Customize choices" menu will appear. Use the ADJUST buttons to select "Auto D.S.T." Then, press the ENTER button to select ON.
- 4 Press the MENU button once to return to the "VCR Main Menu;" press the MENU button a second time to turn off the menus.

▷ **Important:** Do not use this feature if you live in an area that does not observe daylight savings time, such as Arizona, Indiana, or Hawaii.

## Using the auto power saving (auto-off)

With Auto power save on, your VCR will automatically turn off after 30 minutes if you are not using any of the buttons and control or there is no cassette loaded into the VCR.

To use the auto power saving:

- 1 Press the MENU button on the remote control. The "VCR Main Menu" appears on your TV.
- 2 Use the ADJUST buttons on the remote to select "Customize choices" and press the ENTER button.
- 3 The "Customize choices" menu will appear. Use the ADJUST buttons to select "Auto power save." Then, press the ENTER button to set to ON.
- 4 Press the MENU button once to return to the "VCR Main Menu;" press the MENU button a second time to turn off the menus.

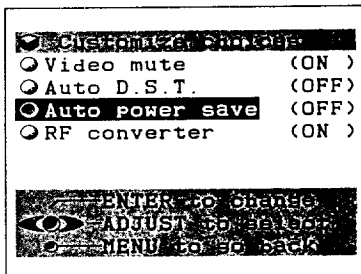

- ▷ **Important:** When you are viewing broadcast stations through VCR, the words “3minutes→Power off” will appear on TV screen three minutes before the VCR power turns off. The display will count down the number of minutes until the VCR turns off. If you want to continue using VCR, load a cassette or press any of the buttons.

### Setting the RF converter

If you are using an older TV without audio and video inputs, the RF converter will need to be set to ON. The setting “RF converter” of the “Customize choices” menu is preset by the factory to ON. If you are using a modern TV with both Audio and Video inputs, you will need to set the RF converter to OFF.

To set the RF converter:

- ❶ Press the MENU button on the remote control. The “VCR Main Menu” appears on your TV.
- ❷ Use the ADJUST buttons on the remote to select “Customize choices.” Press the ENTER button.
- ❸ The “Customize choices” menu will appear. Use the ADJUST buttons to select “RF converter.” Then, press the ENTER button to set the RF converter to ON or OFF.
- ❹ Press the MENU button once to return to the “VCR Main Menu;” press the MENU button a second time to turn off the menus.

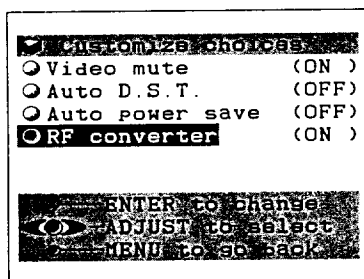
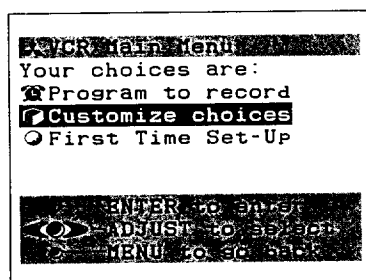

- ▷ **Important:** If the “RF converter” is set to ON, you don’t need to press the VCR/TV button when viewing tapes. The “VCR” light will automatically light up when you press the PLAY/STOP button.

## ◆ Making a Copy of a Tape

There are two basic ways to make a copy of a tape. One way is to use the HS-U270 to play a tape and use another VCR to record. The other way is to use another VCR to play a tape and the HS-U270 to record.

Whichever method you choose, you will need one RCA audio cable and one RCA video cable to connect the two VCRs. If you do not have these cables, they are available at your local electronics retailer. In this section you’ll learn:

- Using your HS-U270 to record from another VCR, and
- Using your HS-U270 to play back to another VCR.

## Using your HS-U270 to record from another VCR

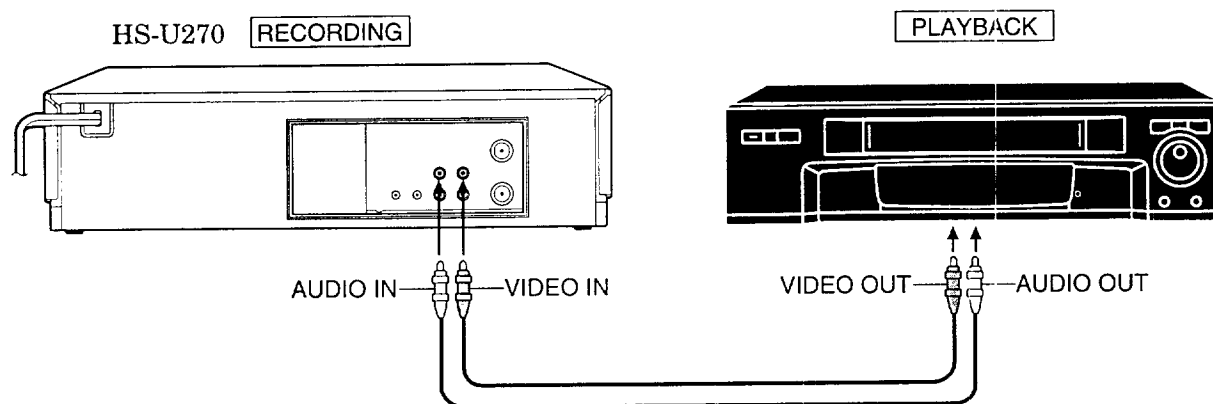

- 1 Connect one RCA audio cable to the AUDIO OUTPUT terminal on the other VCR. Connect the other end of this cable to the AUDIO INPUT terminal on the HS-U270 (labeled AUDIO IN.)
- 2 Connect a video cable to the VIDEO OUTPUT terminal on the playback VCR. Connect the other end of this cable to the VIDEO INPUT terminal on the HS-U270 (labeled VIDEO IN).
- 3 Use the INPUT button to set the HS-U270 to External. ("L" will be displayed on the fluorescent display.)
- 4 Put a blank tape into the HS-U270 and find where you want to begin recording. Press PLAY/STOP.
- 5 Put the tape you want to copy into the other VCR and find the place from which you want to begin copying. Press STOP.
- 6 On the HS-U270, press REC or REC/OTR, then PAUSE.
- 7 On the other VCR, press PLAY, then PAUSE.
- 8 Release the PAUSE button on both VCRs at the same time.
- 9 When finished, press PLAY/STOP (or STOP) on both VCRs.

## Using your HS-U270 to play back to another VCR

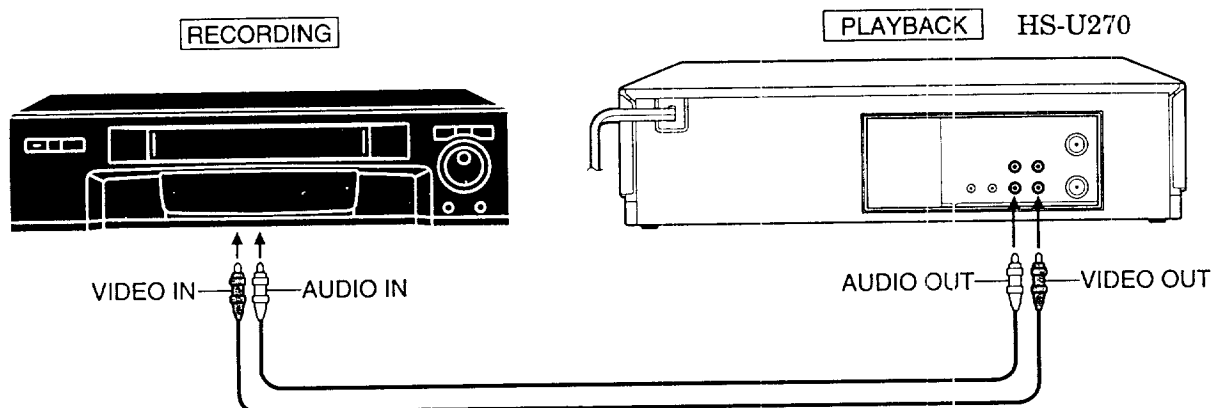

- 1 Connect one RCA audio cable to the AUDIO INPUT terminal on the other VCR. Connect the other end of this cable to the AUDIO OUTPUT terminal on the HS-U270 (labeled AUDIO OUT).
- 2 Connect a video cable to the VIDEO INPUT terminal on the other VCR. Connect the other end of this cable to the VIDEO OUTPUT terminal on the HS-U270 (labeled VIDEO OUT).
- 3 Set the input of the other VCR to "External."
- 4 Put a blank tape into the other VCR and find the place where you want to begin recording. Press STOP.
- 5 Put the tape you want to copy into the HS-U270 and find the place from which you want to begin copying. Press PLAY/STOP.
- 6 On the other VCR, press record (REC), and then PAUSE.
- 7 On the HS-U270, press PLAY/STOP and then PAUSE.
- 8 Release the PAUSE button on both VCRs at the same time.
- 9 Press PLAY/STOP (or STOP) on both VCRs when you are finished.

## ◆ Using Child Lock

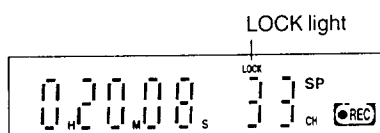

The child lock feature prevents others from using your VCR. To lock the VCR:

- 1 Press and hold down the DISPLAY button on the remote control for about 8 seconds. The LOCK light on the fluorescent display will light up.
- 2 To cancel the child lock, press and hold down the DISPLAY button for about 8 seconds, until the LOCK light goes out.

▷ **Important:** You can lock the VCR with the power off, even if the VCR is standing by for a programmed recording. If you lock the VCR with no cassette in it, the VCR will not accept a cassette.



Problems	Possible Solutions	For More Information
The VCR won't turn on.	<ul style="list-style-type: none"><li>• Check the power cord and the AC outlet.</li><li>• Is the LOCK light ON? If so, press and hold the DISPLAY button for more than 8 seconds until the LOCK light disappears.</li></ul>	See Chapter 1, "Getting to Know Your VCR."
The VCR power is on but no controls work.	<ul style="list-style-type: none"><li>• Turn off the VCR, unplug the power cord and then plug it again after leaving the VCR off for about 2 minutes.</li><li>• Is the LOCK light ON? If so, press and hold the DISPLAY button for more than 8 seconds until the LOCK light disappears.</li></ul>	See Chapter 3, "Operating Your VCR."
You can't see the VCR's picture on your TV.	<ul style="list-style-type: none"><li>• Check the TV's input setting.</li><li>• Check to see that your VCR is not set to "L."</li></ul>	See Chapter 3, "Operating Your VCR."
Poor picture when watching the VCR's tuner on your TV.	<ul style="list-style-type: none"><li>• Check the video channel setting.</li><li>• Check your TV's fine tuning.</li></ul>	See Chapter 3, "Operating Your VCR."
VCR REC button doesn't function.	<ul style="list-style-type: none"><li>• Check the erasure prevention tab on the cassette.</li></ul>	See Chapter 3, "Operating Your VCR."
No picture during recording.	<ul style="list-style-type: none"><li>• Check the hook-up.</li><li>• Check to see if your TV is set to the correct channel or input.</li></ul>	See Chapter 2, "Connecting Your VCR" or Chapter 3, "Operating Your VCR."
VCR does not record TV.	<ul style="list-style-type: none"><li>• Check the VCR tuning.</li><li>• Check the input selection on the VCR. Does the front panel display show "L"? If so, you must switch it to tuner by pressing the INPUT button.</li></ul>	See Chapter 3, "Operating Your VCR."
The VCR timer recording does not operate.	<ul style="list-style-type: none"><li>• Check that the programmed recording light lights up on the fluorescent display.</li><li>• Check the clock time.</li></ul>	See Chapter 3, "Operating Your VCR."
Noise in the picture.	<ul style="list-style-type: none"><li>• Check the tracking control. Adjust manually if necessary.</li></ul>	See Chapter 4, "Using the Advanced Features."
Playback is noisy or "snowy".	<ul style="list-style-type: none"><li>• Try automatic head cleaning.</li><li>• Clean the video head using a dry-type video head cleaning cassette. Do not use a wet-type cleaning cassette, as it may damage your VCR. Excessive use of a cleaning cassette could shorten head life. Be sure to follow the cleaning instructions carefully.</li><li>• Have your VCR video heads cleaned by a qualified service technician.</li></ul>	See Chapter 3, "Operating Your VCR."
VCR remote does not function.	<ul style="list-style-type: none"><li>• Check to see that the remote modes of your VCR and your remote are correctly set.</li><li>• Check to see that the TV/VCR slide switch is set to the correct position.</li></ul>	See Chapter 3, "Operating Your VCR."

Problems	Possible Solutions	For More Information
TV screen blanks out for a fraction of a second when you press the VCR PLAY/STOP button.	<ul style="list-style-type: none"> <li>When you are playing a tape or you are seeing the on-screen menu using Active A/V Network, TV screen blanks out for a fraction of a second. This is normal and will not harm either the TV and VCR.</li> </ul>	
Your converter box or satellite receiver does not respond to any signals from the VCR's Remote Control Transmitter (the small window on top of the VCR).	<ul style="list-style-type: none"> <li>Try moving the cable box so that there is a clear line of sight between the transmitter and the box's remote sensor.</li> <li>Sometimes a cable box needs to be set by the cable company to receive signals. Contact your cable company.</li> <li>You may need to connect a cable (part number, "KIT-CBC" or "INFRARED EMITTER" to the CONVERTER BOX CONTROL terminal on the rear of the VCR. Contact your Mitsubishi dealer for more help.</li> </ul>	See Chapter 3, "Operating Your VCR."

DSS® is a registered trademark of DirecTV, Inc.  
PRIMESTAR® is a registered trademark of PrimeStar Partners, Inc.





- A**  
A/V Network:  
  connecting ..... 18  
  terminals ..... 10  
adding channels ..... 32  
antenna  
  connecting ..... 11  
  terminals ..... 10  
audio  
  connecting a TV with  
    inputs ..... 16  
  function button ..... 9  
  input terminals ..... 10  
  using functions ..... 34  
auto speed programming .... 48
- B**  
batteries  
  installing ..... 20
- C**  
cable box  
  code numbers ..... 31  
  connecting ..... 12  
cable, connecting ..... 11  
cancel button ..... 8  
canceling programmed recording ..... 49  
cassette slot ..... 6  
changing programmed settings ..... 49  
changing settings while programming ..... 42, 46  
channel buttons ..... 7, 9  
channel display ..... 8  
channels  
  adding and deleting ..... 32  
  programming the VCR to receive ..... 29  
  selecting ..... 33  
  VCR Plus+ guides ..... 36  
child lock ..... 60  
cleaning, head ..... 24  
clock, setting ..... 27  
Connecting Your VCR ..... 11  
connecting  
  A/V Network ..... 18  
  antenna ..... 11, 12, 13  
  cable ..... 11  
  cable box ..... 12
- DSS® or PRIMESTAR®  
    receiver ..... 16  
  satellite ..... 16  
  television ..... 14  
  UHF/VHF antennas ..... 13  
converter box  
  control terminal ..... 10  
  transmitter ..... 6  
copying a tape ..... 58  
counter display ..... 7  
counter, time ..... 53  
counter zero stop ..... 55
- D**  
daylight savings time .... 28, 57  
deleting channels ..... 32  
digital tracking (DTR) light .. 7  
display button ..... 9  
dubbing ..... 58
- E**  
eject button ..... 7  
enter button ..... 9  
erasure, preventing tape .... 24  
español ..... 26
- F**  
fast forward button ..... 6, 9  
fast forwarding ..... 25  
features, advanced ..... 51  
fluorescent display ..... 7  
français ..... 26  
Front Panel Buttons and Functions ..... 6
- G**  
guides, VCR Plus+ channel ..... 36
- H**  
head cleaning ..... 24
- I**  
Important Safeguards ..... 2  
index  
  marks ..... 56  
  search ..... 56  
input  
  audio terminal ..... 10  
  button ..... 9  
  video terminals ..... 10  
installing the batteries ..... 20
- L**  
language, selecting ..... 26  
loading tapes ..... 24  
lock light ..... 7  
lock, child ..... 60
- M**  
memorizing channels ..... 29  
memory backup ..... 50  
menu button ..... 9  
menus, using ..... 26  
mute button ..... 8
- N**  
number buttons ..... 8
- O**  
older television, connecting . 15  
one key program button ..... 7  
one key programming ..... 45  
one-touch recording (OTR)  
  button ..... 7  
  using ..... 43
- P**  
pause button ..... 9  
pausing a tape ..... 25  
picture, viewing the one coming from your VCR .... 23  
play button ..... 6, 9  
play light ..... 8  
playback controls ..... 25  
  advanced ..... 51  
power button ..... 7, 8  
programmed recording light . 8  
programming  
  auto speed ..... 48  
  changing settings while ..... 42, 46  
  one key ..... 45  
  the VCR to receive channels ..... 29  
  TV shows that end the day after ..... 49

- programming (cont.)  
VCR Plus+ ..... 42  
VCR to record ..... 39
- Q**  
quick program  
button ..... 9  
using ..... 47  
quick search ..... 54
- R**  
record button ..... 7,8  
record light ..... 8  
recording speed ..... 34  
recording  
canceling ..... 49  
settings ..... 49  
current broadcast ..... 39  
notes about ..... 47  
one key programming ..... 45  
one-touch ..... 43  
programming your  
VCR to ..... 39  
Quick Program ..... 47  
VCR Plus+ ..... 42  
remaining time ..... 53  
remote control  
buttons ..... 8  
installing batteries ..... 20  
overview ..... 8  
sensor ..... 7  
using ..... 20  
repaired tapes ..... 24  
rewind button ..... 6, 9  
rewinding ..... 25  
RF converter ..... 58
- S**  
safeguards, important ..... 2  
satellite  
connecting ..... 16  
memorizing channels ..... 29  
programming to record ..... 39  
search  
index ..... 56  
quick ..... 54  
speed ..... 55  
techniques ..... 54  
setting the time ..... 27  
skipping programs ..... 49  
slow motion ..... 51  
special effects ..... 51
- speed search ..... 55  
stop button ..... 6, 9
- T**  
tape speed light ..... 8  
tape status symbol ..... 8  
tape  
copying ..... 58  
loading ..... 24  
playing ..... 25  
preventing erasure ..... 24  
repaired ..... 24  
unloading ..... 24  
television  
connecting ..... 14  
operating with remote ..... 21  
terminals, rear panel ..... 10  
time counter ..... 53  
time, setting ..... 27  
time  
gauge ..... 53  
present ..... 54  
remaining ..... 53  
tracking ..... 52  
TV/VCR slide switch ..... 9
- U**  
UHF/VHF antennas, connect-  
ing ..... 13  
unloading tapes ..... 24
- V**  
VCR Plus+  
programming with ..... 42  
setting channel guides ..... 36  
VCR/TV button ..... 8  
VCR  
light ..... 7  
locking ..... 60  
operating ..... 19  
operating two with one  
remote ..... 21  
operating with remote ..... 20  
setting up ..... 19  
viewing the picture coming  
from your ..... 23  
vibration, controlling ..... 26  
video  
connecting a TV with Audio  
and Video inputs ..... 16  
function button ..... 9  
input terminals ..... 10
- mute ..... 32  
using functions ..... 34  
volume controls ..... 8



## Guía de Operación Básica de la Videgrabadora

### Funciones básicas de los botones

- ① **botón de encendido (POWER)**  
Oprima este botón para encender y apagar la videgrabadora.
- ② **botón de cancelación (CANCEL)**  
Utilice este botón para cancelar selecciones en los menús en pantalla.
- ③ **botón de grabación (REC)**  
Utilice este botón para comenzar la grabación.
- ④ **botón de pausa (PAUSE)**  
Utilice este botón para pausar una cinta.
- ⑤ **botón de rebobinado, búsqueda hacia atrás y ajuste (REW, - ADJUST)**  
Oprima este botón para rebobinar la cinta o hacer una búsqueda hacia atrás. También utilice este botón para seleccionar o ajustar artículos de menú.
- ⑥ **botón de reproducción, parada e ingreso (PLAY, STOP, ENTER)**  
Oprima este botón para comenzar la reproducción de la cinta, oprima de nuevo para detener la cinta. Durante el uso de los menús en pantalla, utilice este botón para fijar selecciones de menú.
- ⑦ **botón de modalidad (VCR/TV)**  
Oprima este botón para cambiar entre el sintonizador o salida de la videgrabadora, y el sintonizador del televisor.
- ⑧ **botón de canales (CHANNEL)**  
Oprima estos botones para cambiar canales en la videgrabadora.
- ⑨ **botón de adelantado, búsqueda hacia adelante y ajuste (FF, ADJUST+)**  
Oprima este botón para adelantar la cinta o hacer una búsqueda hacia adelante. También, utilice este botón para seleccionar o ajustar artículos de menú.
- ⑩ **botón de menú (MENU)**  
Oprima este botón para utilizar el sistema operativo de menús en pantalla.

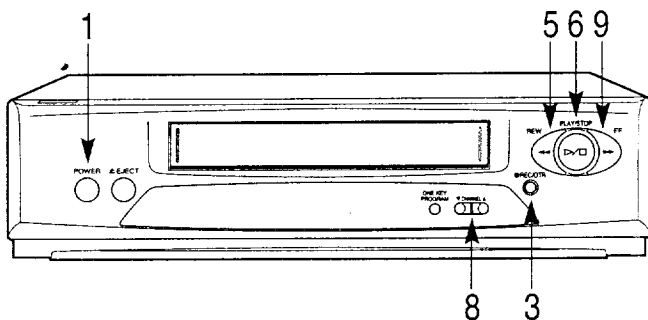
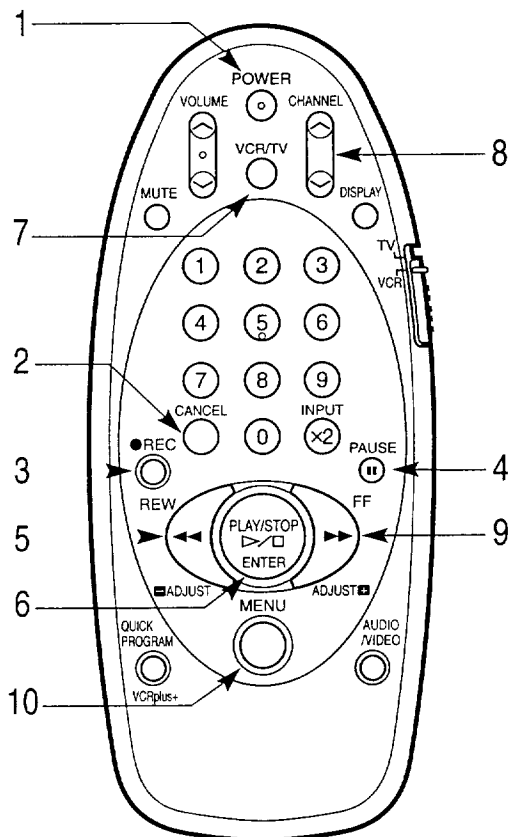

Si desea obtener una guía para esta videgrabadora en Español, sívase llamar al (800) 558-7278 o (770) 734-5526

### Cómo seleccionar el idioma de el sistema operativo de menús en pantalla

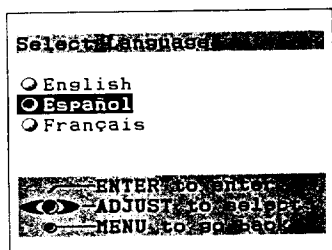

- ❶ Si nunca se ha usado la videgrabadora, vaya al paso ❸.
- ❷ Desenchufe la videgrabadora por más de dos minutos, y vuelvala a enchufar.
- ❸ Oprima el botón POWER para encender la videgrabadora
- ❹ Oprima el botón MENU en el control remoto.
- ❺ Verá el menú de seleccionar el idioma "Select Language." Utilice los botones de ajuste ADJUST – o ADJUST + en el control remoto para seleccionar el idioma.
- ❻ Después de que haya seleccionado el idioma que deseado, oprima el botón PLAY/STOP/ENTER, luego oprima el botón MENU para salir de los menús.

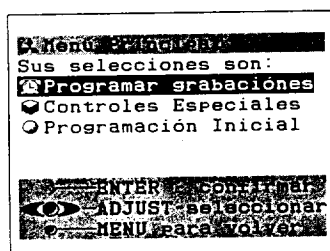

### Cómo poner el reloj

- ❶ Oprima el botón MENU para ver el menú "Menú Principal."
- ❷ Utilice los botones de ajuste ADJUST – o ADJUST + en el control remoto para seleccionar el menú "Programación Inicial", luego oprima el botón PLAY/STOP/ENTER.
- ❸ Utilice los botones de ajuste ADJUST – o ADJUST + en el control remoto para seleccionar el menú "Poner el reloj", luego oprima el botón PLAY/STOP/ENTER.
- ❹ Utilice los botones de ajuste ADJUST – o ADJUST + y el botón PLAY/STOP/ENTER para ajustar el mes, año, día, hora y selección de hora de verano.
- ❺ Al completar los ajustes para poner el reloj, oprima el botón PLAY/STOP/ENTER, luego oprima el botón MENU repetidamente para salir de los menús.

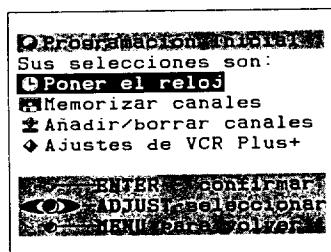

### Cómo programar la videgrabadora par grabar

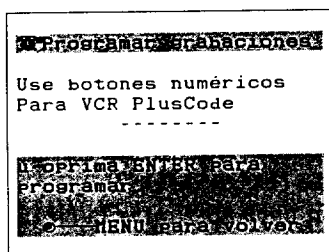

- ❶ Oprima el botón MENU para ver el menú "Menú Principal."
- ❷ Utilice los botones de ajuste ADJUST – o ADJUST + para seleccionar el menú "Programar grabaciones." Luego oprima el botón ENTER.
- ❸ Utilice los botones numéricos para ingresar un código de programación VCR PlusCode, o oprima el botón ENTER.
- ❹ Utilice los botones de ajuste ADJUST – o ADJUST + y el botón PLAY/STOP/ENTER para ajustar el canal, el día, la hora de comienzo, la hora de terminado y la velocidad de la grabación.
- ❺ Al completar la programación de grabaciones, oprima el botón PLAY/STOP/ENTER, luego oprima el botón MENU repetidamente para salir de los menús.

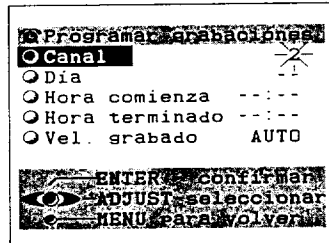

**mitsubishi**  
**VIDEO CASSETTE RECORDER**  
**LIMITED WARRANTY**

MITSUBISHI ELECTRONICS AMERICA, INC. ("MELA") warrants to the original purchaser of this video cassette recorder if purchased from an authorized MITSUBISHI Audio/Video Dealer that, should it prove defective by reason of improper workmanship and/or material:

- a. **Parts.** For one year from the date of original purchase at retail, we will repair or replace, at our option, any defective part including the video head without charge for the part. Parts used for replacement are warranted for the remainder of the original warranty period.
- b. **Labor.** For six months from the date of original purchase at retail, we will provide the labor for a warranty repair without charge at an authorized MITSUBISHI service center.
- c. **Notice.** To obtain warranty service, you must notify an authorized MITSUBISHI service center of any defect within the applicable warranty time period.

1. TO OBTAIN WARRANTY SERVICE, deliver your VCR to the nearest MITSUBISHI service center. Shipping expenses are your responsibility. The name and address of the nearest service center can be obtained from your MITSUBISHI Dealer, or by writing or calling MELA at the address and telephone number below. Proof of purchase date from an authorized MITSUBISHI Dealer is required when requesting warranty service. Present your sales receipt or other document which establishes proof and date of purchase. THE RETURN OF THE OWNER REGISTRATION CARD IS NOT A CONDITION OF WARRANTY COVERAGE. However, please detach and return the Owner Registration Card so that we can contact you should a question of safety arise which could affect you.

2. THIS WARRANTY DOES NOT COVER damage caused by: modification, alteration, repair or service of this product by anyone other than an authorized MITSUBISHI service center; physical abuse to, or misuse of, the VCR; operation in a manner contrary to the instructions which accompany the VCR; freight damage; or any damage caused by acts of God such as lightning or fluctuation in electrical power. This warranty also excludes all costs arising from installation, adjustment of user controls, external antenna systems, service of products purchased or serviced outside the U.S.A., initial technical adjustments (set-up) and user-required maintenance including head cleaning. Consult the operating instructions enclosed with the product for information regarding user controls.

3. ANY EXPRESS WARRANTY NOT PROVIDED HEREIN, AND ANY REMEDY WHICH, BUT FOR THIS PROVISION, MIGHT ARISE BY IMPLICATION OR OPERATION OF LAW, IS HEREBY EXCLUDED AND DISCLAIMED. THE IMPLIED WARRANTIES OF MERCHANTABILITY AND OF FITNESS FOR ANY PARTICULAR PURPOSE ARE EXPRESSLY LIMITED TO A TERM OF ONE YEAR.

4. UNDER NO CIRCUMSTANCES SHALL MELA BE LIABLE TO PURCHASER OR ANY OTHER PERSON FOR ANY INCIDENTAL, SPECIAL OR CONSEQUENTIAL DAMAGES, WHETHER ARISING OUT OF BREACH OF WARRANTY, BREACH OF CONTRACT, OR OTHERWISE.

5. Some states do not allow limitations on how long an implied warranty lasts, or the exclusion or limitation of incidental, special, or consequential damages, so the above limitations or exclusions may not apply to you.

6. This warranty gives you specific legal rights and you may also have other rights which vary from state to state.

7. BEFORE REQUESTING SERVICE, please review the instruction booklet to insure proper installation and correct customer control adjustment. If the problem persists, contact your nearest MITSUBISHI Dealer for name(s) of authorized MITSUBISHI Service Center(s). If you are unable to obtain the information, please call 1-800-332-2119, or write us at the address below.

**MITSUBISHI ELECTRONICS AMERICA, INC.**  
P.O. Box 5025  
Norcross, GA 30091-5025



RETAIN THIS PORTION FOR YOUR RECORDS	SERIAL NO. _____
CUSTOMER NAME _____	
STREET ADDRESS _____	
CITY _____	STATE _____
PHONE (     ) _____	PURCHASE DATE _____ / _____ / _____
	MO     DAY     YR
PLACE OF PURCHASE _____	



MITSUBISHI ELECTRONICS AMERICA, INC.  
6100 Atlantic Boulevard  
Norcross, GA 30071-1305

© 1996 Mitsubishi Electronics America, Inc.

872C151A1

PRINTED IN SINGAPORE