



U509

USER MANUAL

Welcome to use ufone mobile, this manual is to help you know how to well use the phone.

Safety Attentions:

Please read the following information carefully in order for you to use the phone safely and effectively.

Power the phone safely

Please do not power the phone at the locations where the phone is prohibited using or the phone may cause the disturbance or risks.

Traffic safety is first

Please do not use the phone when driving in order not hinder the safety of the driving.

Keep the phone out of stretch of the kids

The phone and its accessories (including fittings) should be kept out of the stretch of the kids.

- Please use the accessories of the original manufacturer or the accessories approved by the manufacturer. The usage of any unapproved accessory will affect the phone performance and damage the phone, even result in the human body risks or in violation of the related national regulations on the communication terminals.
- Please clean the phone with the slightly-wet and static-free clothing. Do not use the dry or static-prone clothing. Please note not to use the chemicals such as detergents when cleaning the phone surface. Please power the phone off when cleaning the phone.
- Please do not place your phone near the magnetic memory medium such as PC disk. The phone may disturb the TV, radio, PC, thus affecting the call performance when using the phone near them.
- Do not let the phone exposed to the strong sunlight in avoidance of being heated.
- Do not enter various liquids into the phone in avoidance of the damaged.
- Do not throw and strike the phone, do not crudely treat and damage the internal circuit board of the phone.
- Do not connect the phone with other device not supporting the phone.
- Keep away from fire



Volume adjust:

Adjust device's volume.

Menu button:

Open the list of options available on the current screen.

Home button:

Return to the Home screen; Open the list of the recent applications (press and hold).

Back button:

Return to the previous screen.

Power on/off:

Turn on/off the device (press and hold);

Lock the screen or turn it on.



This version is dual-card standby over-time phone which can be inserted with 2 SIM cards. SIM card is included in the socket generally. The SIM card is inserted in the Socket. You should be careful to use,insert and disassemble the SIM card because of the SIM card damage owing that the contact of the SIM card is easy to be scrapped or bent or damaged.

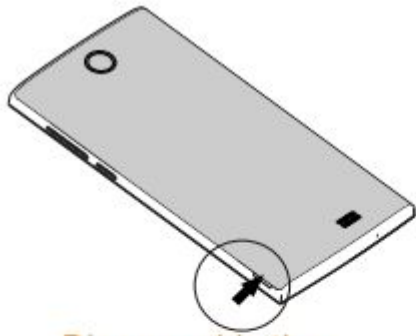

Disassemble the battery cover



Slide the SIM card into the socket

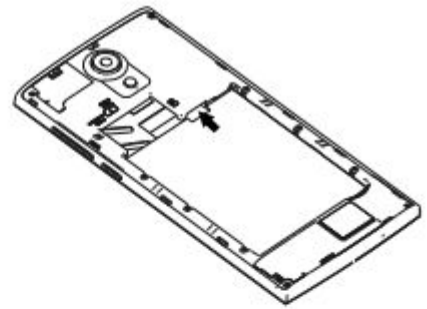

Insert the SD-card

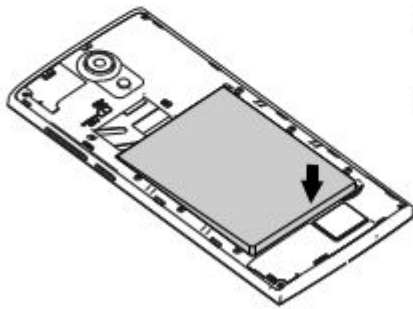

Insert the battery

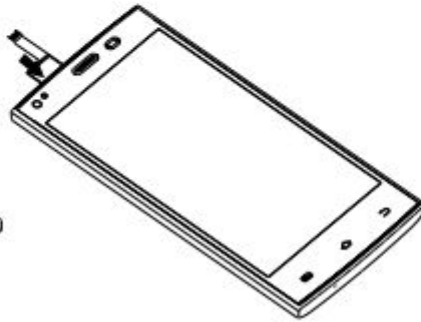

Insert the USB cable

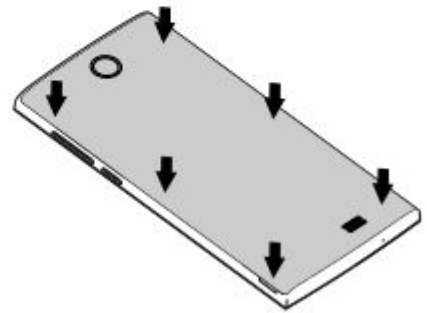

Cover the battery

Lock and unlock the screen

Drag the indicator to the right side of the screen to unlock the device. Press the power on/off button to lock the screen.

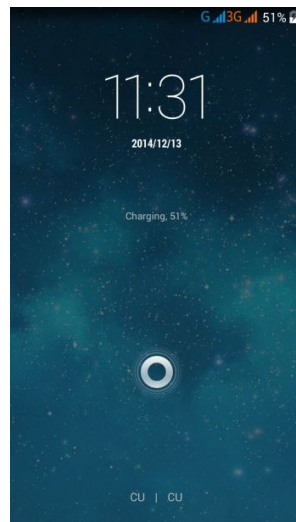

Enter to desktop

Basic functions will show on the desktop when unlock the device.

Corresponding process will run when you press the icon.

And long-press then could sort the icons as you like.

You could uninstall the software just drag it to ash-bin on the top of the screen.



Contacts

Learn to create and manage a list of your personal or business contacts. You can save names, phone numbers, email addresses, and more for your contacts.

Create a contact.

Press “+” icon, and select a memory locations. Enter contact information. Select “Confirm” to add the contact to memory.

Find a contact

Scroll up or down the contact list . Select a contact’s name. From the contact view, you can use the following option: Make a call, Send a message, edit contact, share, print, delete contact and so on.

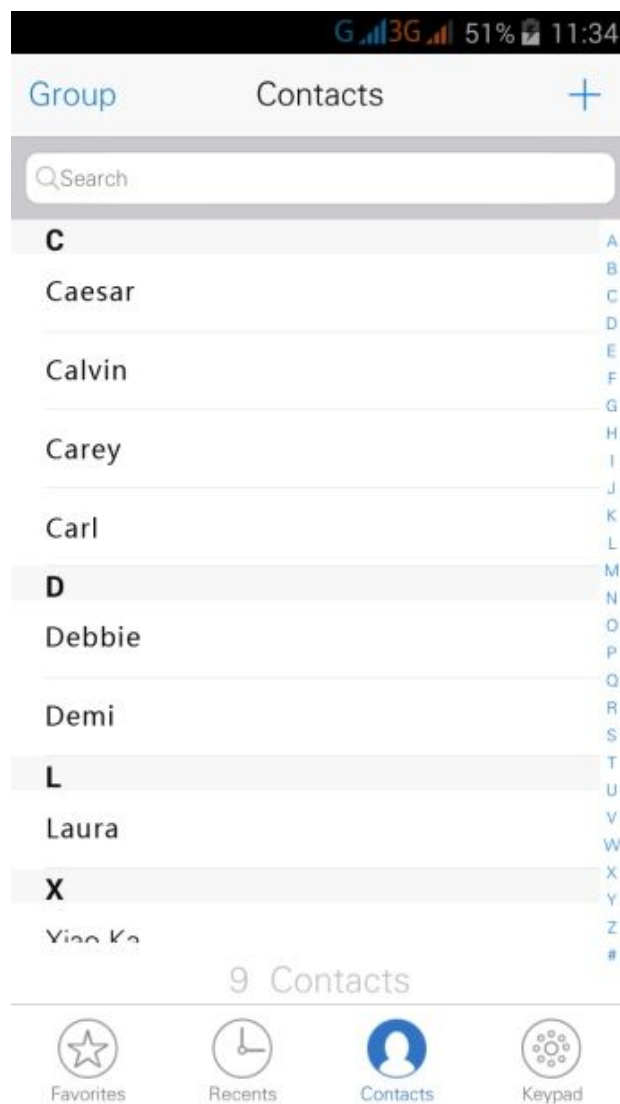

Calling

Learn to use calling functions, such as making and answering calls, using options available during a call, or customizing and using call-related features.

Make a call:

Tap the dialer icon, and then enter an input interface and press a phone number. To access the call log and redial numbers you have called recently. To access the contact list and select on to dial.

Answer a call:

During an incoming call, press the answer icon and drag forward right.

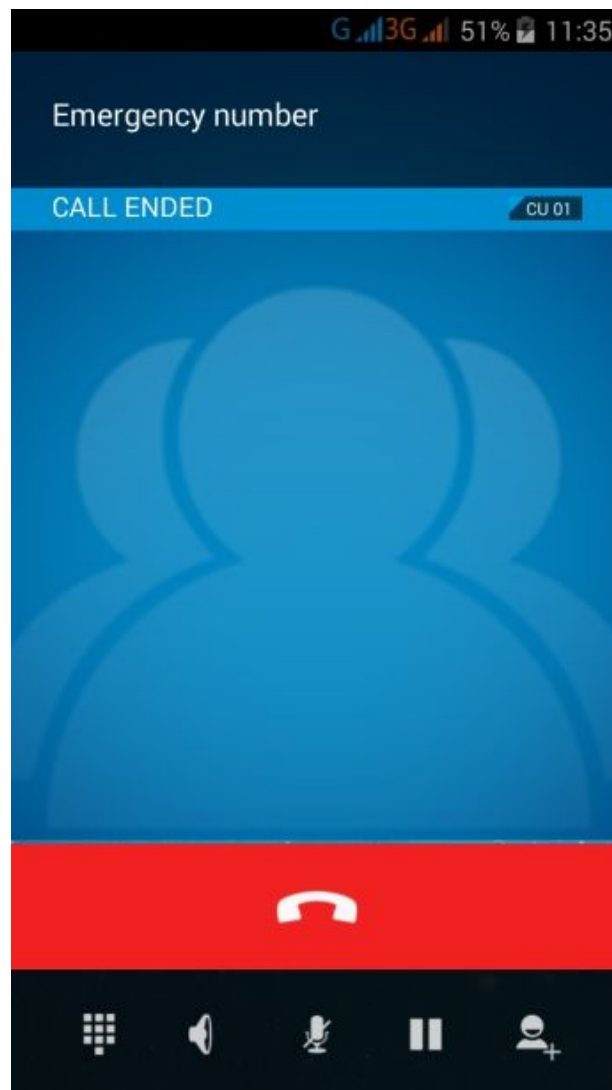

Message

Learn to create and send text(SMS) or multimedia(MMS) messages, and view or manage messages that you have sent or received.

You could set one or more receivers and it supports to insert pictures, video and audio in message.

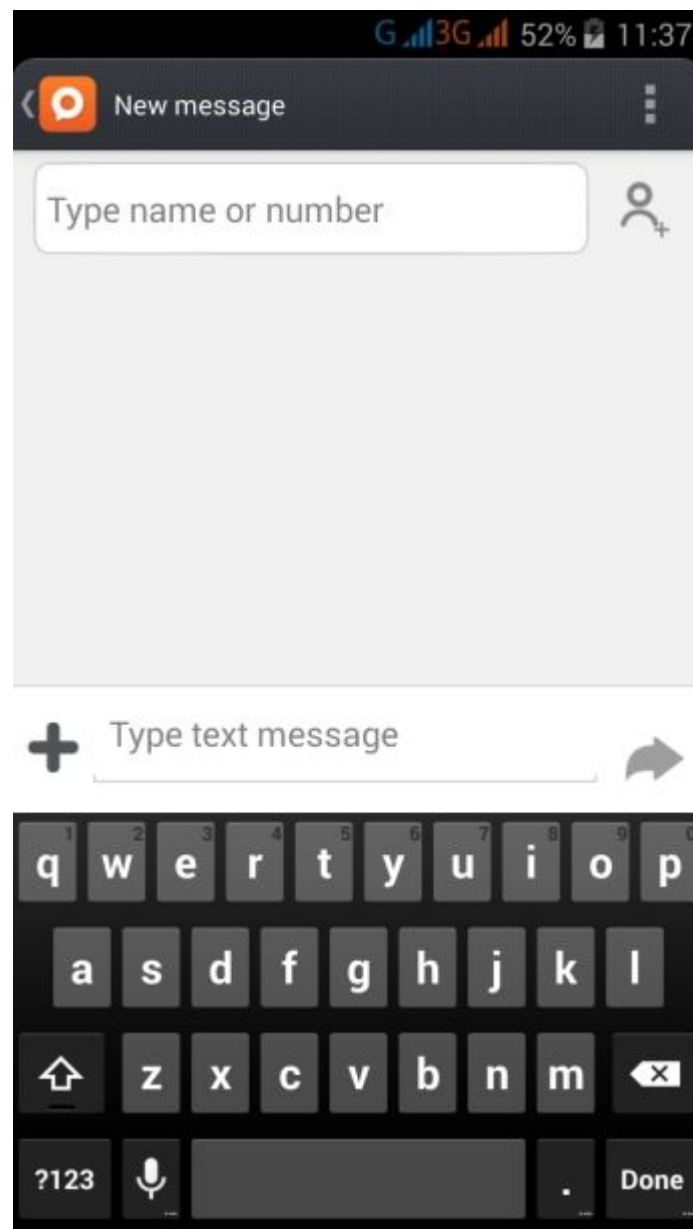

Email

Setting email account then you could send or receive email freely.

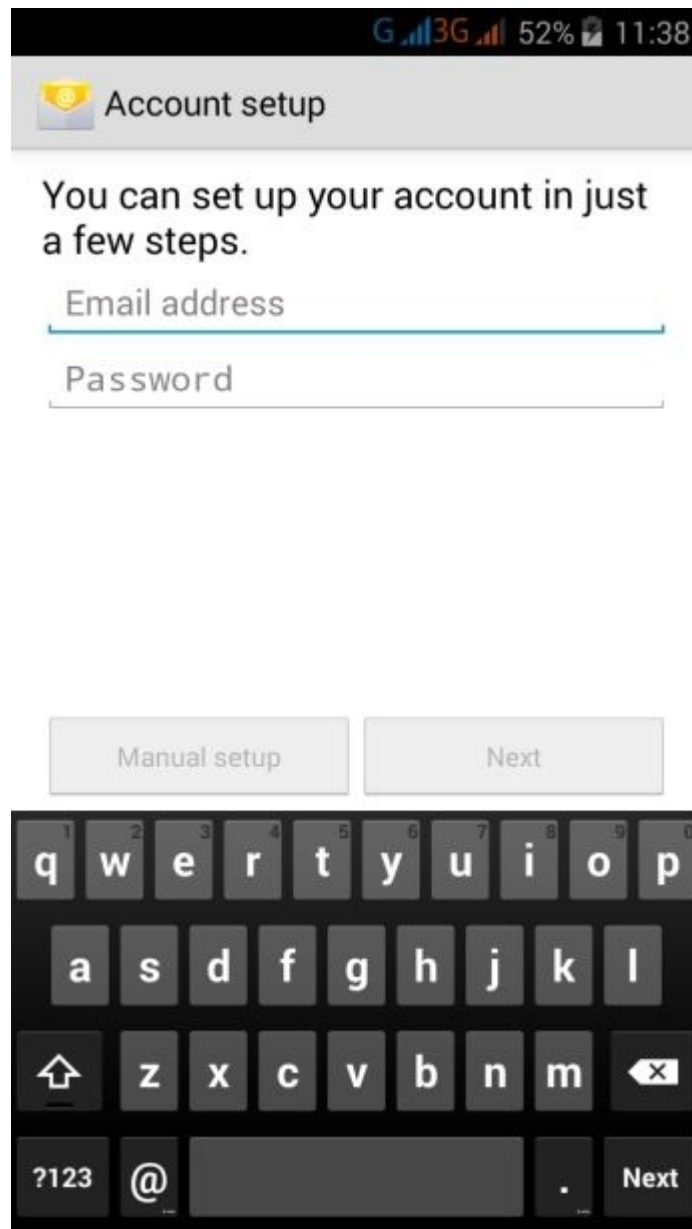

Camera

Camera supports auto adjust the lens,time-fixed photograph, special effect.

Record video when switch to video function in the option.



Gallery

Pictures saved-in folder. The picture could be shared in many software such as Facebook, Twitter, Gmail or Skype.



Music

Music progress supports play music locally or online music and supports batch download.

It could show detail information such as artists, albums and so on.



Browser

To zoom in or out, place two fingers on the screen and slowly spread them apart or pinch them together. To return to the original size, double-tap the screen.

This feature may be unavailable on some webpages.

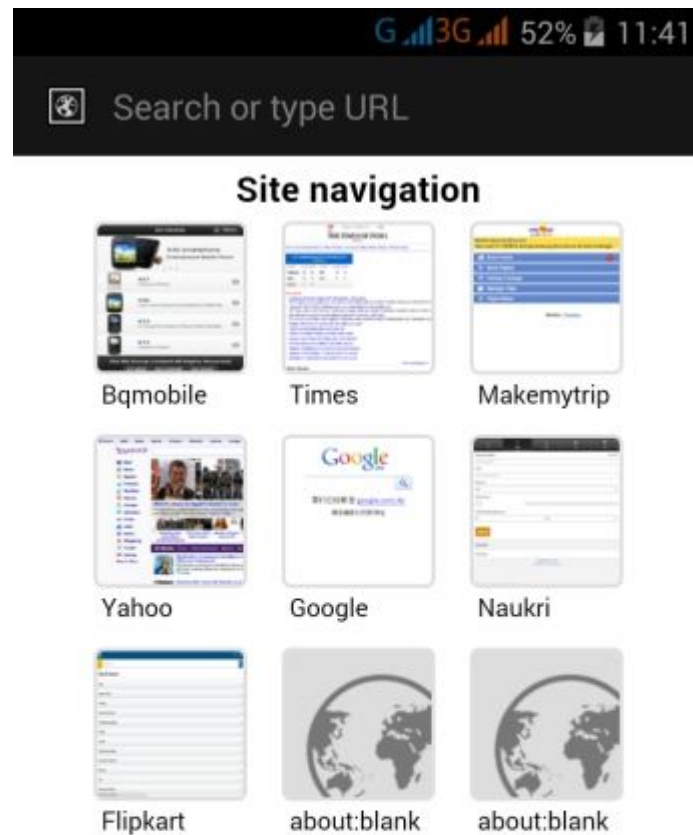

Multi tasks convert

The device supports multi-tasks run together at the same time.

To switchover or clear them just long-press the home button.

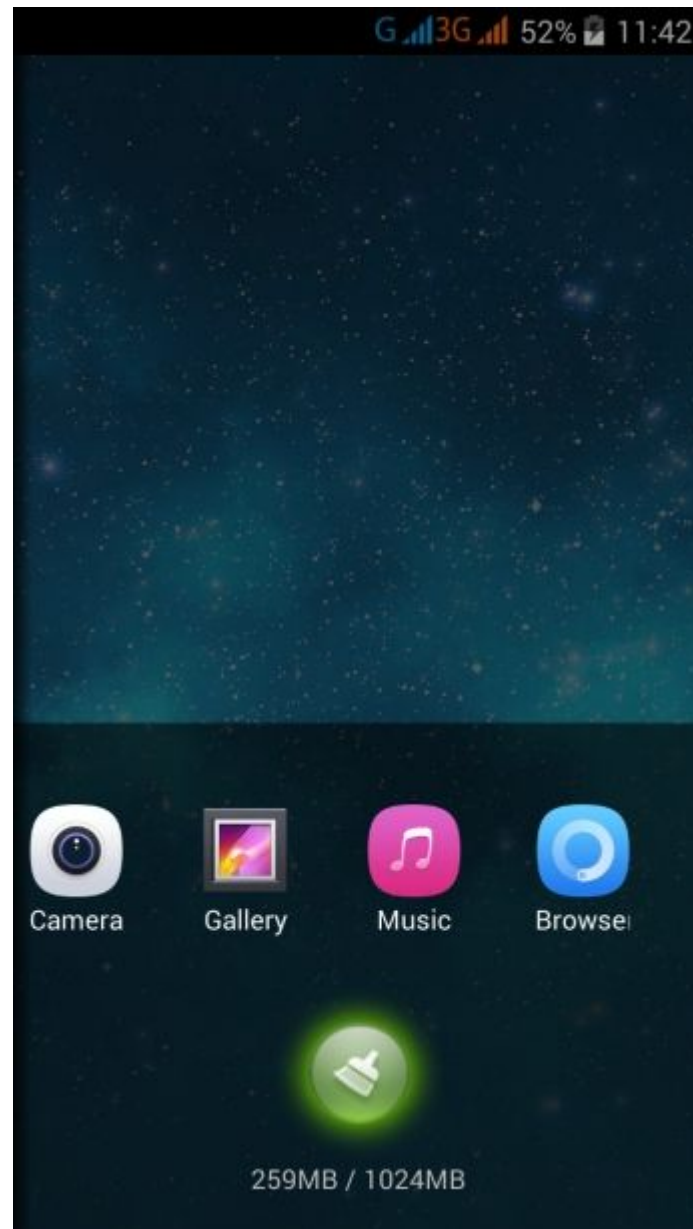

Wallpaper change

Select menu button and choose wallpaper to achieve wallpaper change.

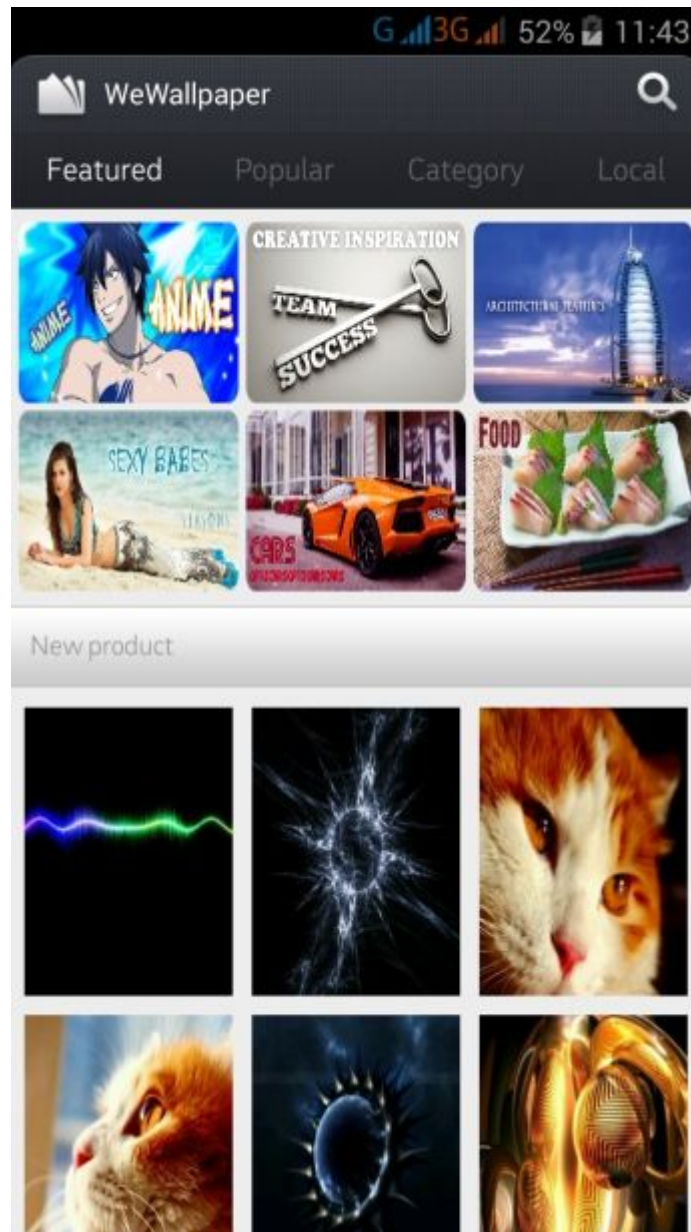

We Store

In menu you can find WE store icons, you can download the Game, Utilities、Audio-Video、Chat and Social etc which you like.

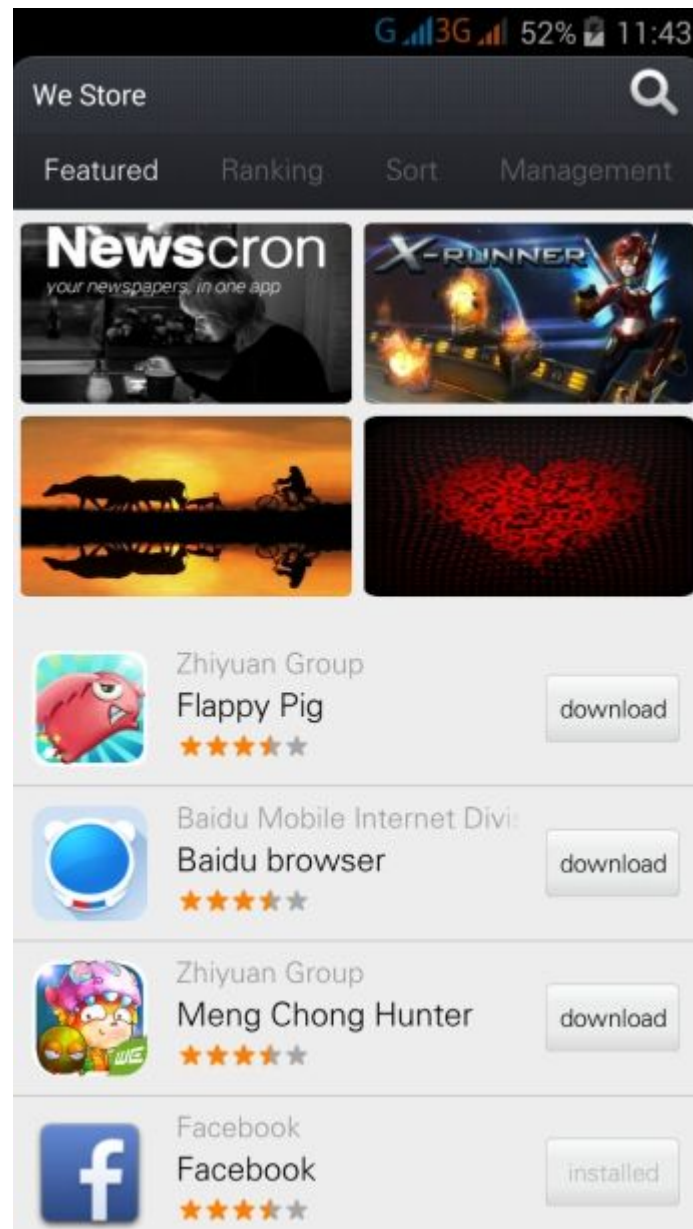

Check the toggles

Press screen and drag it from the top of the screen to the bottom.

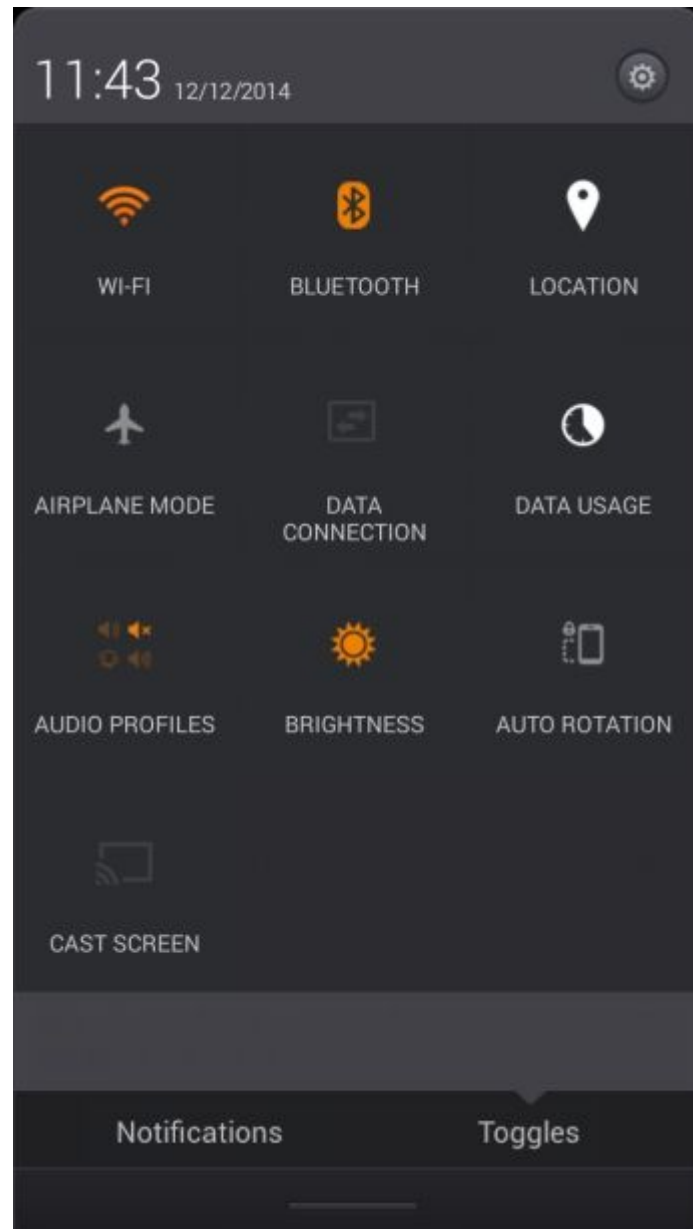

FAQs and Solutions

You can check the phone simply before contacting with the post sales server in order for you to avoid the excessive maintenance time and expense waste.

Cannot power the phone on:

- Check whether the Powering-on key is pressed and hold for 2 second or above.
- Check whether the battery is contacted badly or not.Please remove the battery firstly and then try to power the phone on.
- Check whether the battery capacity is used UP or not;please charge the battery.

Upon power-on,there is information displayed:

- Input PIN:select the function of inputting PIN when the phone is powered on .The PIN shall be input.
- Input PUK:after the PIN is input wrongly for successively 3times,the phone will be locked.
- PUK provided by the network operator should be input.

SIM card error

- There is some dirt on the metal surface of the SIM card,please wipe the metal contacts of the SIM card with a clean cloth.
- SIM card is not installed. You should install the SIM card based on the User's Manual.
- SIM card is damaged.Please contact with your network supplier.

Cannot access to network

- The signal is weak , please move to the place where the signal is strong and retry.
- Beyond the coverage of the network of the network sever.
- SIM card is invalid, please contact with your network supplier.

Cannot dial out

- Please confirm whether the dial key send is pressed after the number is dialed.
- Please confirm whether the call is barred due to owned toll.
- Please confirm whether the SIM card is valid or not.
- Please confirm whether the call restriction function is set UP.
- Please confirm whether the fixed dial function is set UP.

Bad call quality

- Check whether the volume is adjusted appropriately.
- Use the phone at the place where the receiving quality is not good, such as near to the building or in the basement where the radio wave cannot reach.
- Use the phone at the peak time, such as at the time of going on/off the duty, the channel is congested.

Contact cannot call you

- Please confirm that the phone is powered on and is unlinked with network.

- Please confirm that the call is barred because of owned toll.
- Please confirm whether the SIM card is valid.
- Please confirm whether the fixed dial function is set UP.

Contact cannot hear you

- Please confirm that the microphone is opened
- Please keep the microphone at the bottom of the phone close to your mouth.

Short standby time

- The stand-by time is relevant to the system setup. The phone is possibly at the place where the signal state is bad. When the phone cannot receive the signal, the phone will transmit to search the base station continuously; consuming a great deal of battery capacity and shortening the stand-by time of the battery. Please move to the place where the signal is strong to use the phone or temporarily power the phone off.
- The battery requires to be displaced with a new battery.

Cannot charge

- Bad contact! Please check that the plug is connected well;
- Wipe the interfaces of the phone and battery with soft and dry clothing.
- Charge at the environment below -20°C or beyond 55°C . Please change the charging environment;

The battery or adapter is damaged and requires to be replaced;

- Please record the phone model and SN, authorized or insurance

information and detailed statement and then contact with the local after sales service if the aforementioned instruction cannot facilitate you to conquer these problems.

SAR VALUE

- Max SAR for Head: 0.539W/Kg(1g)
- Max SAR for Body: 0.730W/Kg(1g)

FCC Caution:

Any Changes or modifications not expressly approved by the party responsible for compliance could void the user's authority to operate the equipment.

This device complies with part 15 of the FCC Rules. Operation is subject to the following two conditions: (1) This device may not cause harmful interference, and (2) this device must accept any interference received, including interference that may cause undesired operation.

Note: This equipment has been tested and found to comply with the limits for a Class B digital device, pursuant to part 15 of the FCC Rules. These limits are designed to provide reasonable protection against harmful interference in a residential installation. This equipment generates, uses and can radiate radio frequency energy and, if not installed and used in accordance with the instructions, may cause harmful interference to radio communications. However, there is no guarantee that interference will not occur in a particular installation. If this equipment does cause harmful interference to radio or television reception, which can be determined by turning the equipment off and on, the user is encouraged to try to correct the interference by one or more of the following measures:

- Reorient or relocate the receiving antenna.
- Increase the separation between the equipment and receiver.
- Connect the equipment into an outlet on a circuit different from that to which the receiver is connected.
- Consult the dealer or an experienced radio/TV technician for help.

Specific Absorption Rate (SAR) information

SAR tests are conducted using standard operating positions accepted by the FCC with the phone transmitting at its highest certified power level in all tested frequency bands, although the SAR is determined at the highest certified power level, the actual SAR level of the phone while operating can be well below the maximum value, in general, the closer you are to a wireless base station antenna, the lower the power output.

Before a new model phone is available for sale to the public, it must be tested and certified to the FCC that it does not exceed the exposure limit established by the FCC, Tests for each phone are performed in positions and locations (e.g. at the ear and worn on the body) as required by the FCC.

For body worn operation, this model phone has been tested and meets the FCC RF exposure guidelines when used with an accessory designated for this product or when used with an accessory that contains no metal and that positions the handset a minimum of 1.0cm from the body.

Non-compliance with the above restrictions may result in violation of RF exposure guidelines.