

MR. COFFEE®



TM1 SERIES

MAKES 2 QUARTS OF COLD, REFRESHING ICED TEA
IN LESS THAN 10 MINUTES

Iced Tea Maker

READ ALL INSTRUCTIONS BEFORE USING THIS APPLIANCE

INTRODUCTION

CONGRATULATIONS! You are the owner of a MR. COFFEE® iced tea maker. This unique appliance has been designed to provide you with excellent tasting iced tea quickly and conveniently.

Please read **all** of the instructions in this booklet carefully before you begin to use this appliance. Proper care and maintenance will ensure the long life of this appliance and its trouble-free operation. Save these instructions and refer to them often for cleaning and care tips.

TABLE OF CONTENTS

	PAGE
Introduction	2
Important Safeguards	3
Cord Set Instructions	4
Precautions	4
Diagram of Parts	5
Instructional Illustrations	6
Brewing Iced Tea and Iced Coffee	7
Cleaning Instructions	9
Pitcher Cleaning	10
If Service is Required	11
Warranty Information	12

THIS PRODUCT IS FOR HOUSEHOLD USE ONLY!

For Questions or Service Call

1-800-672-6333 (U.S.A. & Canada)

Monday – Friday, 9:00 A.M. until 6:00 P.M., Eastern Standard Time

Saturday, 9:00 A.M. until 3:00 P.M., Eastern Standard Time

IMPORTANT SAFEGUARDS

When using electrical appliances, basic safety precautions should always be followed to reduce the risk of fire, electric shock, and/or injury to persons, including the following:

1. **READ ALL INSTRUCTIONS BEFORE USING THE MACHINE.**
2. Do not touch hot surfaces. Use handles or knobs.
3. To protect against electric shock, do not immerse cord, plugs or machine in water or any other liquid.
4. Close adult supervision is necessary when this appliance is used by or near children.
5. Unplug from outlet when not in use and before cleaning. Allow to cool before putting on or taking off parts, and before cleaning the appliance.
6. Do not operate any appliance with a damaged cord or plug or after the appliance malfunctions, or has been damaged in any manner. Return this appliance only to the nearest authorized service center for examination, repair or adjustment.
7. The use of accessory attachments not recommended for MR. COFFEE® products may cause hazards or injuries.
8. Do not use outdoors.
9. Do not let cord hang over edge of table or counter, or touch hot surfaces.
10. Do not place this appliance on or near a hot gas or electric burner or in a heated oven.
11. To disconnect, remove plug from outlet wall.
12. Do not use appliance for other than intended use.
13. Use on a hard, flat level surface only, to avoid interruption of air flow underneath the appliance.
14. **Pitcher Use and Care**
Breakage may occur if the following instructions are not followed:
 - a. This pitcher is designed for use with this iced tea maker and therefore must never be used on a rangetop or in any oven, including a microwave.
 - b. Do not use a cracked pitcher.
 - c. Do not clean the pitcher with cleansers, steel wool pads, or other abrasive materials.
 - d. Avoid sharp blows, scratches, or rough handling.
15. **WARNING:** To reduce the risk of fire or electric shock, do not remove any service covers. No user serviceable parts inside. Repair should be done by authorized personnel only.
16. Pitcher is not dishwasher safe.

SAVE THESE INSTRUCTIONS

SPECIAL CORD SET INSTRUCTIONS

1. A short power supply cord is provided to reduce the hazards resulting from becoming entangled in or tripping over a longer cord.
 2. An extension cord may be purchased and used if care is exercised in its use.
 3. If an extension cord is used, the marked electrical rating of the extension cord must be at least 10 amps and 120 volts. The resulting extended cord must be arranged so that it will not drape over the countertop or tabletop where it can be pulled on by children or tripped over accidentally.
- **This appliance has a polarized plug (one blade is wider than the other). To reduce the risk of electric shock, this plug will fit in a polarized outlet only one way. If the plug does not fit fully in the outlet, reverse the plug. If it still does not fit, contact a qualified electrician. Do not modify the plug in any way.**

PRECAUTIONS WHEN USING THIS MACHINE

- Place the machine well back from the edge of the counter.
 - To stop the brewing cycle before completed, grasp the molded plug and unplug.
 - Avoid areas which may become hot or emit steam when the machine is on, particularly the steeping basket and water reservoir. The steeping basket lid must be on while the machine is brewing.
 - Unplug the unit when not in use or when wiping the exterior. Wipe with a damp cloth only.
- TO MAINTAIN THE QUALITY OF PARTS, WE RECOMMEND HAND WASHING ONLY. THESE ITEMS ARE NOT DISHWASHER SAFE.**
- DO NOT operate the machine unless the pitcher and steeping basket with the lid on are snug against the machine.
 - DO NOT move the machine while in use or afterwards, until it has cooled. Steam may escape from the steeping basket while the unit is cooling.
 - DO NOT place a cloth or otherwise restrict airflow beneath the appliance.
 - Avoid jerking or straining the power cord when unplugging. Grasp the molded plug to unplug.
 - This machine is not designed for commercial use.
 - Never reheat a beverage by passing it through the brewing system.
 - Do not permit children to use this machine unless under close adult supervision.

Clean Before First Use

1. Wash the pitcher, steeping basket, steeping basket lid and pitcher lid in mild detergent and water. Rinse each thoroughly. **THESE ITEMS ARE NOT DISHWASHER SAFE.**
WARNING: To prevent injury from hot steam, do not plug the unit in until water is in the reservoir and the pitcher is in place.
2. Fill the pitcher with water to the top water level mark on the pitcher and pour into the water reservoir. Do not overfill.
3. Place ice cubes in the pitcher to the top of the ice level mark on the pitcher.
4. Place the steeping basket, with lid, into the pitcher, and slide under the machine. **Make sure the pitcher is pushed snug against the machine** (See Figure C).
5. Plug the cord into an electrical outlet and push the ON button to begin the brewing cycle. The indicator light will illuminate to let you know the machine is ON (See Figure D).
6. When the water has cycled through, the unit will shut off automatically. The indicator light will turn OFF to let you know the cycle is complete.
7. Slide the pitcher away from the machine (See Figure E).
8. Remove steeping basket and discard the water in the pitcher.

DIAGRAM OF PARTS

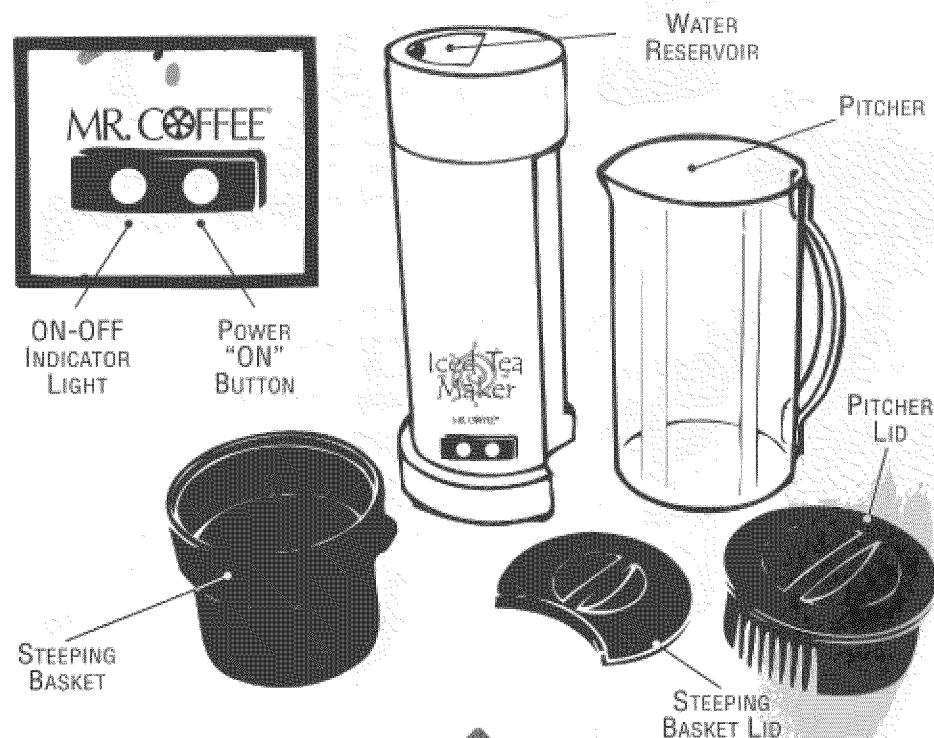

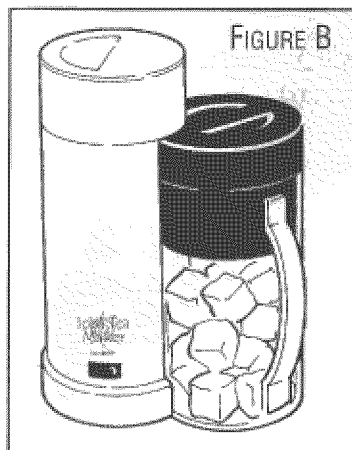

FIGURE B

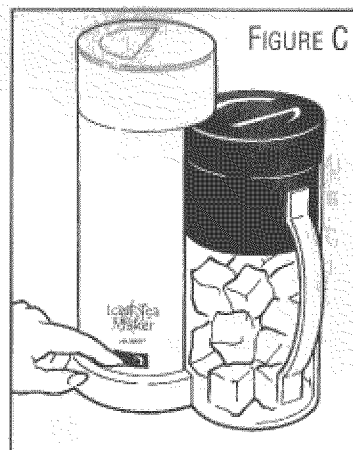

FIGURE C

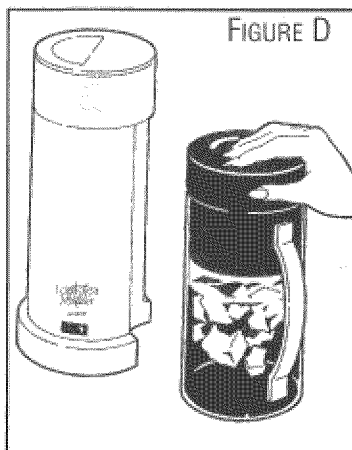

FIGURE D

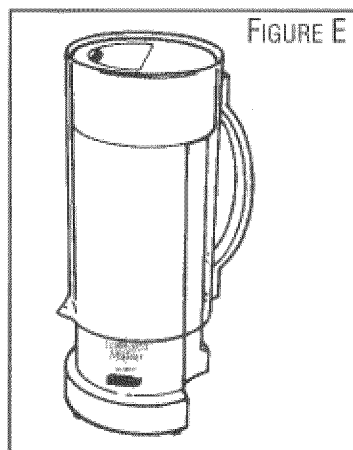

FIGURE E

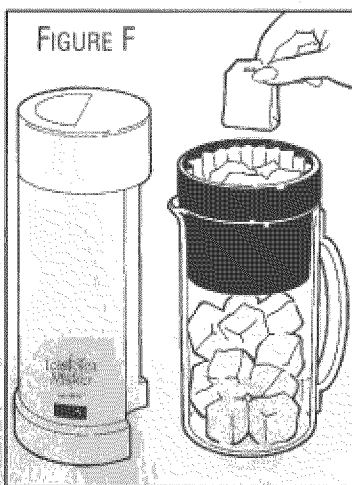

FIGURE F

Instructional Illustrations

Figure A / Diagram of Parts

Figure B / Pitcher is snug against the machine

Figure C / Push button to turn on

Figure D / Slide pitcher away from the machine

Figure E / Pitcher stores upside down over the machine when not in use

Figure F / Place the steeping basket on top of the pitcher

TEA AND COFFEE MEASUREMENT CHART

To Make	TEA	COFFEE
2 Quarts	6-10 regular bags or 2 - 4 level Tbsp. of loose tea	5 - 7 coffee scoops or 10 - 14 level Tbsp.
1 Quart*	3 - 5 regular bags or 1 - 3 level Tbsp. of loose tea	3 - 4 coffee scoops or 6 - 8 level Tbsp.

*When brewing only 1 quart of tea, fill the water and ice levels to half the amount used for 2 quarts.

Helpful Hints

1. Use more or less tea or coffee to suit your taste. Additional tea bags may be needed when using herbal tea.
2. If your ice supply is low, you can substitute with cold tap water. After filling the water reservoir with the proper amount of water, refill the pitcher with cold tap water a second time to the desired WATER level. Refrigerate to chill.
3. Tea may turn cloudy as it chills due to the tannic acids found in tea. Higher quality teas will contain more tannic acids than others. Using less tea will reduce the cloudiness.
4. For extra flavor, try adding several bags of herbal or flavored tea to your brew.
5. For excellent iced coffee, try dark roast coffee or any other flavored coffee.

To Brew Iced Tea

Please refer to Pages 5 and 6 for *Diagram of Parts* and *Instructional Illustrations*.

1. Fill the water pitcher with tap water to the desired capacity. (When brewing only 1 Quart, fill to half the amount used for 2 Quarts). **Do Not Overfill.** **WARNING: To prevent injury from hot steam, do not plug the unit in until water is in the reservoir and the pitcher is in place.**
2. Pour the water into the water reservoir.
3. Fill the pitcher with ice cubes to the desired capacity as marked on the pitcher. (When brewing only 1 Quart, fill to half the amount used for 2 Quarts).
4. Place the steeping basket on top of the pitcher (See Figure F).
5. Place a 8-12 cup basket size MR. COFFEE® paper filter into the steeping basket.

6. Put desired amount of tea bags or loose tea into the filter. (See *Tea and Coffee Measurement Chart listed previously*). Sugar, lemon or other flavorings can also be added at this time. For best results use 1 ounce or 2 Tbsp. of sugar. When using loose tea, add 2 ounces or 4 Tbsp. of sugar. These amounts will completely dissolve in the pitcher during the brewing cycle. If you should desire more sugar, add it directly into the pitcher after brewing. It may be helpful when using loose tea, to use two filters. Place one filter on the bottom of the steeping basket. Place desired amount of loose tea (and sugar) into filter. Nest the second filter on top of the loose tea (and sugar). Only 8-12 cup basket filters should be used. Place steeping lid on top of steeping basket.

CAUTION: Do not operate the machine unless the pitcher and steeping basket with lid on are pushed snug against the machine. Otherwise, hot water and steam could escape.

7. Plug the power cord into the electrical outlet and push the ON button to begin the brewing cycle (See *Figure D*). The indicator light will illuminate to let you know the machine is on. **NOTE:** If you wish to turn the machine off during the brewing cycle, grasp the molded plug and unplug the power cord.

8. When the brewing cycle is completed, the unit will shut off automatically. The indicator light will go out to let you know the brewing cycle is completed.

9. Slide the pitcher away from the machine (See *Figure D*).

CAUTION: Some residual steam may escape from the machine when the cycle is complete. For your safety, please slide the pitcher away from the machine before you continue.

10. When the tea has drained, remove the steeping basket and replace it with the pitcher lid. You are now ready to serve refreshingly cold iced tea.

11. Discard the contents of the steeping basket. Rinse out the steeping basket and lid with water **after each use**.

12. If you have left over tea, cover the pitcher with the pitcher lid and store it in the refrigerator.

13. When the machine is not in use, the pitcher stores upside down on the machine (See *Figure E on Page 6*).

To Brew Iced Coffee

Follow the instructions for iced tea using the suggested amount of coffee in the chart listed on Page 7.

CAUTION: Decaffeinated coffee, particularly when used with chemically softened water, can cause slower filtration.

Daily Care

To maintain the quality of all parts and minimize tea stains, we recommend washing the pitcher, pitcher lid, steeping basket and lid with warm water and a mild detergent, regularly. **THESE ITEMS ARE NOT DISHWASHER SAFE.**

Hard water can leave whitish mineral deposits inside the pitcher and steeping basket. Tea and coffee discolor these deposits. To remove, fill the basket and pitcher with warm white vinegar and let it soak for about 20 minutes.

Do not use harsh, abrasive cleaners. They will cause scratches which can lead to breakage.

Deliming

This unit must be delimed when you begin to notice an increase in steaming or if the pumping action stops before all the water has been pumped out of the machine.

The frequency of cleaning depends on the hardness of water used. Listed below are the suggested cleaning intervals.

SUGGESTED CLEANING INTERVAL	Type of Water	Cleaning Frequency
	Soft Water	Every 80 Brew Cycles
	Hard Water	Every 40 Brew Cycles

This iced tea maker may be delimed using vinegar or MR. COFFEE® CLEANER, which works better than vinegar and has no unpleasant odor. Please refer to Pages 5 and 6 for *Diagram of Parts* and *Instructional Illustrations*. MR. COFFEE® CLEANER may be purchased at your local retailer or by writing or calling the Consumer Service Department listed on Page 11.

Using MR. COFFEE® CLEANER:

(Read caution statement on side panel of MR. COFFEE® CLEANER box before use.)

1. Fill pitcher with warm water to the water level marked on the pitcher. (36 ounces of warm water)
2. Empty contents of one packet of MR. COFFEE® CLEANER into pitcher. Mix thoroughly to dissolve cleaner. This will make a clear blue solution.
3. Pour entire contents of pitcher into the water reservoir of the iced tea maker.
4. Place one tray of ice cubes in the pitcher.
5. Place steeping basket, with lid, into the pitcher and slide the pitcher under the machine. **The pitcher must be placed snug against the machine before operation.**

6. Push the ON button to begin the brewing cycle. The indicator light will illuminate to let you know the machine is brewing. When the machine has pumped out all the cleaning solution, the unit will turn itself off automatically and the indicator light will go out.
7. Remove steeping basket and discard contents of pitcher. Rinse pitcher, steeping basket, and lid thoroughly with water.
8. Repeat Steps 1 through 8 with clean water only (*no cleaning solution*) to rinse out the machine.
9. Be sure to thoroughly rinse the unit until you see no trace of the blue solution. When completed, wash pitcher, steeping basket, and lid with mild detergent and rinse thoroughly.
10. If a normal brewing flow rate is not achieved, repeat the cleaning procedure.

Using Vinegar:

1. Pour 1 quart of undiluted white household vinegar into the water reservoir.
2. Place one tray of ice cubes in pitcher.
3. Place the steeping basket with lid into the pitcher and slide it under the machine. **The pitcher must be placed snug against the machine before operation.**
4. Push the ON button to begin the brewing cycle. After approximately 1 cup of vinegar has pumped into the pitcher, unplug the appliance and allow it to sit for 30 minutes.
5. Plug the cord back in and turn the machine ON to pump out the remaining vinegar.
6. When the machine shuts off, remove the pitcher and discard the vinegar.
7. Fill the pitcher with clear tap water to the water level marked on the pitcher and repeat Steps 1 through 4 (*no vinegar*). Turn the machine ON to rinse out all traces of vinegar.
8. Repeat rinsing procedure.

Pitcher Cleaning

Hard water can leave whitish mineral deposits inside the pitcher. Tea and coffee discolor these deposits. To remove, fill the pitcher with hot white vinegar and let soak for about 20 minutes. Do not use harsh abrasive cleaners. They will cause scratches which can lead to breakage.

Helpful Hints

Fresh tap water should be used in the machine at all times. **DO NOT USE HOT WATER.**

Use only genuine MR. COFFEE® 8-12 cup basket filters for best brewing performance.

Avoid using chemically softened water whenever possible. The use of chemically softened water can inhibit proper filtration. This will affect the beverage flavor and will cause a long drip time from the steeping basket.

IF SERVICE IS REQUIRED, DO NOT RETURN TO YOUR STORE

For Service, call 1-800-672-6333

9:00 A.M. to 6:00 P.M. Eastern Standard Time, Monday through Friday

9:00 A.M. to 3:00 P.M. Eastern Standard Time, Saturday

To assist us in serving you, please have the model number Series TM1 and date of purchase available.

All repairs must be made by an Authorized Sunbeam Service Center. Please call us for the authorized service center in your area.

PLEASE DO NOT RETURN THIS APPLIANCE TO YOUR STORE.

We welcome your questions, comments or suggestions. In all your communications, please include your complete name, address and telephone number and description of problem.

Consumer Service Department
Sunbeam Products, Inc.
P.O. Box 948389
Maitland, FL 32794-8389

1-YEAR LIMITED WARRANTY

Sunbeam Products, Inc. ("Sunbeam") warrants that for a period of **ONE** year from the date of purchase, this product will be free from defects in material and workmanship. Sunbeam, at its option, will repair or replace this product or any component of the product found to be defective during this warranty period. Replacement will be made with a new or remanufactured product or component. If the product is no longer available, replacement may be made with a similar product of equal or greater value. This is your exclusive warranty.

This warranty is valid for the original retail purchaser from the date of initial retail purchase and is not transferable. Keep the original sales receipt. Proof of purchase is required to obtain warranty performance. Sunbeam dealers, service centers or retail stores selling Sunbeam products do not have the right to alter, modify or in any way change the terms and conditions of this warranty.

This warranty does not cover normal wear of parts or damage resulting from any of the following: negligent use or misuse of the product, use on improper voltage or current, use contrary to the operating instructions, disassembly, repair or alteration by anyone other than Sunbeam or an Authorized Service Center. Further, the warranty does not cover Acts of God, such as fire, flood, hurricanes and tornadoes.

Sunbeam shall not be liable for any incidental or consequential damages caused by the breach of any express or implied warranty. Except to the extent prohibited by applicable law, any implied warranty of merchantability or fitness for a particular purpose is limited in duration to the duration of the above warranty. Some states, provinces or jurisdictions do not allow the exclusion or limitation of incidental or consequential damages or limitations on how long an implied warranty lasts, so the above limitations or exclusion may not apply to you. This warranty gives you specific legal rights, and you may also have other rights that vary from state to state or province to province.

HOW TO OBTAIN WARRANTY SERVICE

Take the product to an Authorized Sunbeam Service Center. You can find the nearest Authorized Sunbeam Service Center by calling **1-800-672-6333**. If a Service Center is not conveniently located, attach a tag to the product that includes your name, address, daytime telephone number and description of the problem. Include a copy of the original sales receipt. Carefully package the product and send either by UPS or Parcel Post with shipping and insurance prepaid to:

SUNBEAM SERVICE CENTER
c/o Warranty Center
117 Industrial Row
Purvis, MS 39475

DO NOT RETURN THIS PRODUCT TO THE PLACE OF PURCHASE.

If you have any questions regarding this warranty please call 1-800-672-6333.

MR. COFFEE®

A Product of Sunbeam Products, Inc.
Boca Raton, FL 33431

Printed in China
12/02

P.N. 6366