

OPERATOR'S MANUAL

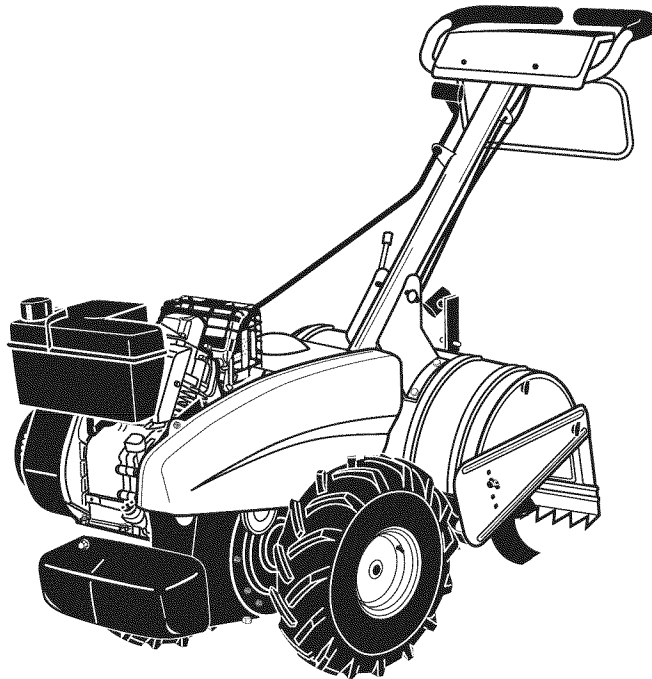

Rear Tine Tiller — Model Series 410

⚠ WARNING

**READ AND FOLLOW ALL SAFETY RULES AND INSTRUCTIONS IN THIS MANUAL
BEFORE ATTEMPTING TO OPERATE THIS MACHINE.
FAILURE TO COMPLY WITH THESE INSTRUCTIONS MAY RESULT IN PERSONAL INJURY.**

MTD LLC, P.O. BOX 361131 CLEVELAND, OHIO 44136-0019

Thank You

Thank you for purchasing a Garden Tiller manufactured by MTD LLC. It was carefully engineered to provide excellent performance when properly operated and maintained.

Please read this entire manual prior to operating the equipment. It instructs you how to safely and easily set up, operate and maintain your machine. Please be sure that you, and any other persons who will operate the machine, carefully follow the recommended safety practices at all times. Failure to do so could result in personal injury or property damage.

All information in this manual is relative to the most recent product information available at the time of printing. Review this manual frequently to familiarize yourself with the machine, its features and operation. Please be aware that this Operator's Manual may cover a range of product specifications for various models. Characteristics and features discussed and/or illustrated in this manual may not be applicable to all models. MTD LLC reserves the right to change product specifications, designs and equipment without notice and without incurring obligation.

This product has met the rigid safety standards of the Outdoor Power Equipment Institute and an independent testing laboratory. If you have any problems or questions concerning the machine, phone your local authorized MTD service dealer or contact us directly. MTD's Customer Support telephone numbers, website address and mailing address can be found on this page. We want to ensure your complete satisfaction at all times.

Throughout this manual, all references to *right* and *left* side of the machine are observed from the operating position

The engine manufacturer is responsible for all engine-related issues with regards to performance, power-rating, specifications, warranty and service. Please refer to the engine manufacturer's Owner's/Operator's Manual, packed separately with your machine, for more information.

Table of Contents

Safe Operation Practices	3	Maintenance & Adjustment	13
Assembly & Set-Up	6	Service	15
Controls & Features.....	10	Troubleshooting.....	16
Operation.....	11	Replacement Parts	17

Record Product Information

Before setting up and operating your new equipment, please locate the model plate on the equipment and record the information in the provided area to the right. You can locate the model plate by standing at the operator's position and looking down at the front right corner of the tine shield. This information will be necessary, should you seek technical support via our web site, Customer Support Department, or with a local authorized service dealer.

MODEL NUMBER

--	--	--	--	--	--	--	--	--	--	--	--

SERIAL NUMBER

--	--	--	--	--	--	--	--	--	--	--	--

Customer Support

Please do NOT return the machine to the retailer or dealer without first contacting our Customer Support Department.

If you have difficulty assembling this product or have any questions regarding the controls, operation, or maintenance of this machine, you can seek help from the experts. Choose from the options below:

- ◇ Visit us on the web at www.mtdproducts.com
- ◇ Call a Customer Support Representative at (800) 800-7310 or (330) 220-4683
- ◇ Write us at MTD LLC • P.O. Box 361131 • Cleveland, OH • 44136-0019



WARNING! This symbol points out important safety instructions which, if not followed, could endanger the personal safety and/or property of yourself and others. Read and follow all instructions in this manual before attempting to operate this machine. Failure to comply with these instructions may result in personal injury.

When you see this symbol. **HEED ITS WARNING!**

CALIFORNIA PROPOSITION 65



WARNING! Engine Exhaust, some of its constituents, and certain vehicle components contain or emit chemicals known to State of California to cause cancer and birth defects or other reproductive harm.



WARNING! Battery posts, terminals, and related accessories contain lead and lead compounds, chemicals known to the State of California to cause cancer and reproductive harm. *Wash hands after handling*



DANGER! This machine was built to be operated according to the safe operation practices in this manual. As with any type of power equipment, carelessness or error on the part of the operator can result in serious injury. This machine is capable of amputating fingers, hands, toes and feet. Failure to observe the following safety instructions could result in serious injury or death.

Training

1. Read, understand, and follow all instructions on the machine and in the manual(s) before attempting to assemble and operate. Keep this manual in a safe place for future and regular reference and for ordering replacement parts.
2. Be familiar with all controls and their proper operation. Know how to stop the machine and disengage them quickly.
3. Never allow children under 14 years of age to operate this machine. Children 14 and over should read and understand the instructions and safe operation practices in this manual and on the machine and be trained and supervised by an adult.
4. Never allow adults to operate this machine without proper instruction.
5. Keep the area of operation clear of all persons, particularly small children and pets. Stop machine if anyone enters the area.
2. Wear sturdy, rough-soled work shoes and close fitting slacks and shirt. Loose fitting clothes or jewelry can be caught in moving parts. Never operate this machine in bare feet or sandals.
3. Disengage clutch levers and shift (if provided) into neutral ("N") before starting the engine.
4. Never leave this machine unattended with the engine running.
5. Never attempt to make any adjustments while engine is running, except where specifically recommended in the operator's manual.

Safe Handling of Gasoline:

To avoid personal injury or property damage use extreme care in handling gasoline. Gasoline is extremely flammable and the vapors are explosive. Serious personal injury can occur when gasoline is spilled on yourself or your clothes which can ignite. Wash your skin and change clothes immediately.

- a. Use only an approved gasoline container.
- b. Never fill containers inside a vehicle or on a truck or trailer bed with a plastic liner. Always place containers on the ground away from your vehicle before filling.

Preparation

1. Thoroughly inspect the area where the equipment is to be used. Remove all stones, sticks, wire, and other foreign objects which could be tripped over and cause personal injury.

- c. When practical, remove gas-powered equipment from the truck or trailer and refuel it on the ground. If this is not possible, then refuel such equipment on a trailer with a portable container, rather than from a gasoline dispenser nozzle.
 - d. Keep the nozzle in contact with the rim of the fuel tank or container opening at all times until fueling is complete. Do not use a nozzle lock-open device.
 - e. Extinguish all cigarettes, cigars, pipes and other sources of ignition.
 - f. Never fuel machine indoors.
 - g. Never remove gas cap or add fuel while the engine is hot or running. Allow engine to cool at least two minutes before refueling.
 - h. Never over fill fuel tank. Fill tank to no more than ½ inch below bottom of filler neck to allow space for fuel expansion.
 - i. Replace gasoline cap and tighten securely.
 - j. If gasoline is spilled, wipe it off the engine and equipment. Move unit to another area. Wait 5 minutes before starting the engine.
 - k. To reduce fire hazards, keep machine free of grass, leaves, or other debris build-up. Clean up oil or fuel spillage and remove any fuel soaked debris.
 - l. Never store the machine or fuel container inside where there is an open flame, spark or pilot light as on a water heater, space heater, furnace, clothes dryer or other gas appliances.
11. After striking a foreign object, stop the engine, disconnect the spark plug wire and ground against the engine. Thoroughly inspect the machine for any damage. Repair the damage before starting and operating.
 12. Disengage all clutch levers (if fitted) and stop engine before you leave the operating position (behind the handles). Wait until the tines come to a complete stop before unclogging the tines, making any adjustments, or inspections.
 13. Never run an engine indoors or in a poorly ventilated area. Engine exhaust contains carbon monoxide, an odorless and deadly gas.
 14. Muffler and engine become hot and can cause a burn. Do not touch.
 15. Use caution when tilling near fences, buildings and underground utilities. Rotating tines can cause property damage or personal injury.
 16. Do not overload machine capacity by attempting to till soil too deep at too fast of a rate.
 17. If the machine should start making an unusual noise or vibration, stop the engine, disconnect the spark plug wire and ground it against the engine. Inspect thoroughly for damage. Repair any damage before starting and operating.
 18. Keep all shields, guards, and safety devices in place and operating properly.
 19. Never pick up or carry machine while the engine is running.
 20. Use only attachments and accessories approved by the manufacturer. Failure to do so can result in personal injury.
 21. If situations occur which are not covered in this manual, use care and good judgement. Contact Customer Support for assistance and the name of you nearest servicing dealer..

Operation

1. Do not put hands or feet near rotating parts. Contact with the rotating parts can amputate hands and feet.
2. Do not operate machine while under the influence of alcohol or drugs.
3. Never operate this machine without good visibility or light. Always be sure of your footing and keep a firm hold on the handles.
4. Keep bystanders away from the machine while it is in operation. Stop the machine if anyone enters the area.
5. Be careful when tilling in hard ground. The tines may catch in the ground and propel the tiller forward. If this occurs, let go of the handle bars and do not restrain the machine.
6. Exercise extreme caution when operating on or crossing gravel surfaces. Stay alert for hidden hazards or traffic. Do not carry passengers.
7. Never operate the machine at high transport speeds on hard or slippery surfaces.
8. Exercise caution to avoid slipping or falling.
9. Look down and behind and use care when in reverse or pulling machine towards you.
10. Start the engine according to the instructions found in this manual and keep feet well away from the tines at all times.

Maintenance & Storage

1. Keep machine, attachments and accessories in safe working order.
2. Allow a machine to cool at least five minutes before storing. Never tamper with safety devices. Check their proper operation regularly.
3. Check bolts and screws for proper tightness at frequent intervals to keep the machine in safe working condition. Also, visually inspect machine for any damage.
4. Before cleaning, repairing, or inspecting, stop the engine and make certain the tines and all moving parts have stopped. Disconnect the spark plug wire and ground it against the engine to prevent unintended starting.
5. Do not change the engine governor settings or over-speed the engine. The governor controls the maximum safe operating speed of engine.
6. Maintain or replace safety and instruction labels, as necessary.
7. Follow this manual for safe loading, unloading, transporting, and storage of this machine.
8. Always refer to the operator's manual for important details if the machine is to be stored for an extended period.

9. If the fuel tank has to be drained, do this outdoors.
10. Observe proper disposal laws and regulations for gas, oil, etc. to protect the environment.

Notice Regarding Emissions

Engines which are certified to comply with California and federal EPA emission regulations for SORE (Small Off Road Equipment) are certified to operate on regular unleaded gasoline, and may include the following emission control systems: Engine Modification (EM), Oxidizing Catalyst (OC), Secondary Air Injection (SAI) and Three Way Catalyst (TWC) if so equipped.

Spark Arrestor



WARNING! This machine is equipped with an internal combustion engine and should not be used on or near any unimproved forest-covered, brushcovered or grass-covered land unless the engine's exhaust system is equipped with a spark arrester meeting applicable local or state laws (if any).

If a spark arrester is used, it should be maintained in effective working order by the operator. In the State of California the above is required by law (Section 4442 of the California Public Resources Code). Other states may have similar laws. Federal laws apply on federal lands.

A spark arrester for the muffler is available through your nearest engine authorized service dealer or contact the service department, P.O. Box 361131 Cleveland, Ohio 44136-0019.

Average Useful Life

According to the Consumer Products Safety Commission (CPSC) and the U.S. Environmental Protection Agency (EPA), this product has an *Average Useful Life* of seven (7) years, or 130 hours of operation. At the end of the *Average Useful Life*, buy a new machine or have the machine inspected annually by an authorized service dealer to ensure that all mechanical and safety systems are working properly and not worn excessively. Failure to do so can result in accidents, injuries or death.



WARNING! Your Responsibility—Restrict the use of this power machine to persons who read, understand and follow the warnings and instructions in this manual and on the machine.

SAVE THESE INSTRUCTIONS!

Contents of Carton

- One Tiller
- One Depth Stake
- One Handlebar Assembly
- One Operator's Manual
- One Shift Rod
- One Engine Operator's Manual

Assembly

Unpacking Instructions

NOTE: References to the right or left side of the tiller are determined from behind the machine in the operating position.

1. Remove the staples, break the glue on the top flaps, or cut the tape at the end of the carton and peel it along the top flap to open.
2. Remove any loose parts included with the tiller (i.e., the Operator's Manual, etc.).
3. Cut the corners and lay the carton down flat.
4. Remove the packing material.
5. Roll or slide the tiller out of the carton. Check the carton thoroughly for loose parts.
6. Extend the control cable and lay it on the floor. Be careful not to bend or kink the control cable.

NOTE: This machine is shipped without gasoline or oil in the engine. Be certain to service the engine with gasoline and oil as instructed in the separate Engine Operator's Manual before operating.

Depth Stake



WARNING! Before assembly, disconnect the spark plug wire and ground it against the engine to prevent unintended starting.

1. Tip the tiller forward so that it rests on the front counterweight.
2. Unthread the "T" knob from the top of the depth stake and remove the flat washer and hex bolt. Remove the cotter pin from the clevis pin. See Fig. 3-1.

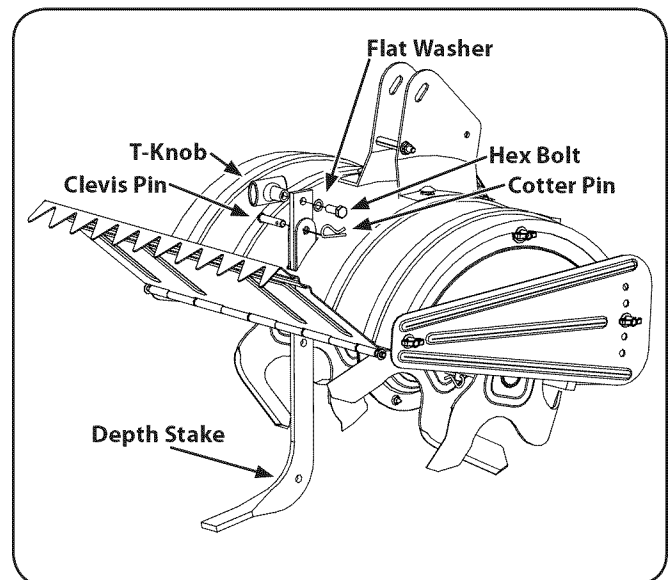

Figure 3-1

3. Raise the tine shield hinge flap assembly and insert the depth stake assembly into the slot, under the tine shield and up through the tine shield assembly.
4. Insert the clevis pin through the tine shield and depth stake assemblies. Secure it with the cotter pin.
5. Insert the hex bolt into the top hole of the depth stake assembly. Place the flat washer on the hex bolt and thread the T-knob onto the hex bolt. Tighten securely. See Fig. 3-1.
6. Tip the tiller back down so that it rests on the tines.

Handlebar Assembly

1. Remove the handle adjustment crank, flange nut, retainer bracket, shoulder bolt, and lock nut from the pivot bracket.
2. Place the handle assembly into position in the handle pivot bracket by lining up the upper holes in the handle with the slots in the pivot bracket. See Fig. 3-2.

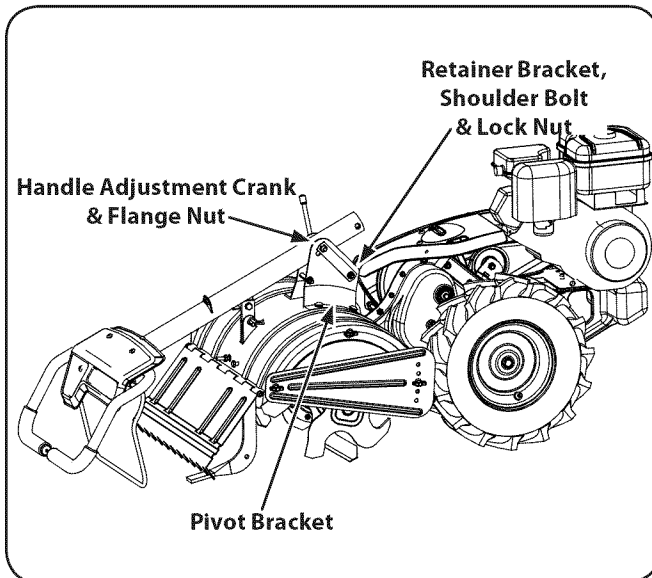

Figure 3-2

3. Lift up the handle assembly and align the bottom holes in the handle assembly with the holes in the pivot bracket. Insert the shoulder bolt from the left side of the tiller through the pivot bracket and the retainer bracket on the right hand side of the tiller. See Fig. 3-3.

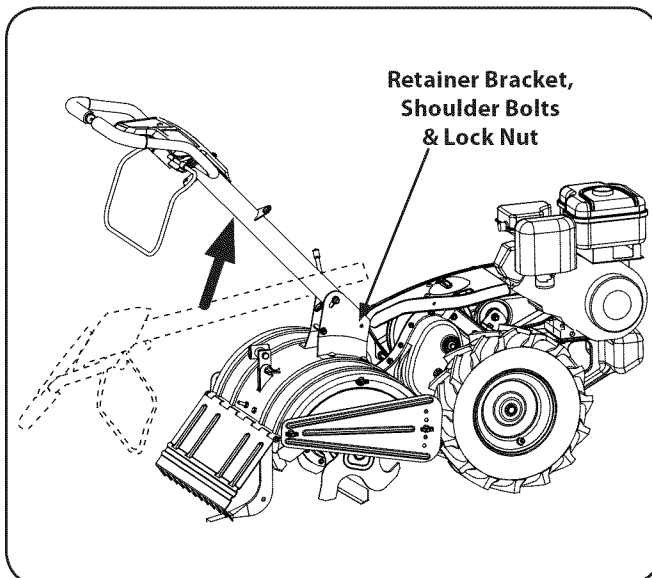

Figure 3-3

4. Place the hex opening of the flange nut retainer bracket over the flange nut securing the handle adjustment crank and install the lock nut on the lower shoulder bolt. See Fig. 3-4.

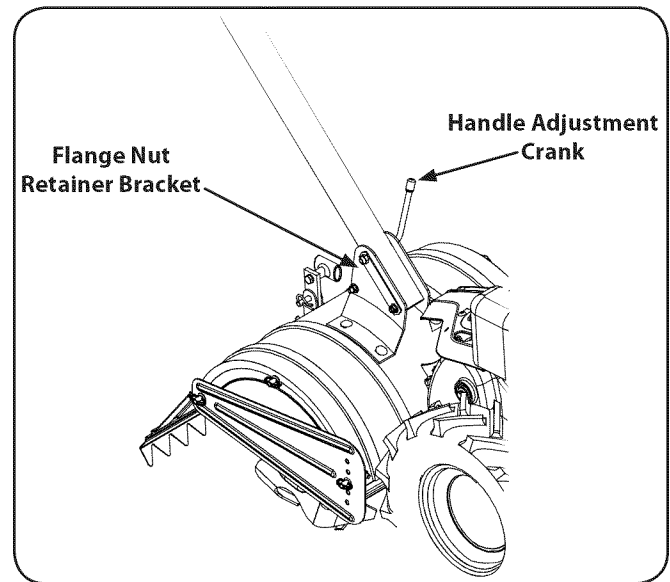

Figure 3-4

5. Pivot the handle assembly into the desired position. Tighten the bottom bolt, lock nut, and the handle adjustment lock securely.

Gear Shift Rod

1. Remove the T-handle, cotter pin, flat washer and rubber washer from the end of the gear shift rod.
2. Slide the rod up through the right side of bracket on the front of the handle assembly. See Fig. 3-5.

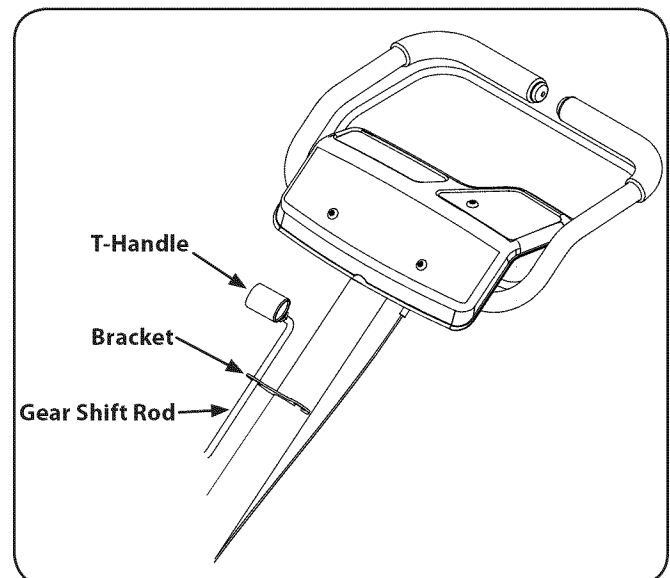

Figure 3-5

3. Insert the end of the gear shift rod through the opening in the top of the shift cover and into the shift bracket. First, secure the rubber washer then the flat washer and cotter pin. See Fig. 3-6.

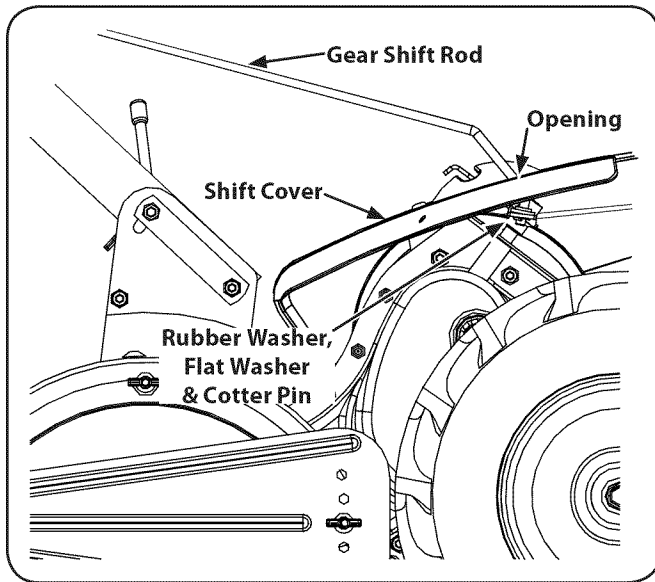

Figure 3-6

4. Install the nut and T-handle on the gear shift rod.

Clutch Cable

1. Route the clutch cable underneath the handle and through the cable clip. Be careful not to bend or kink the cable. See Fig. 3-7.

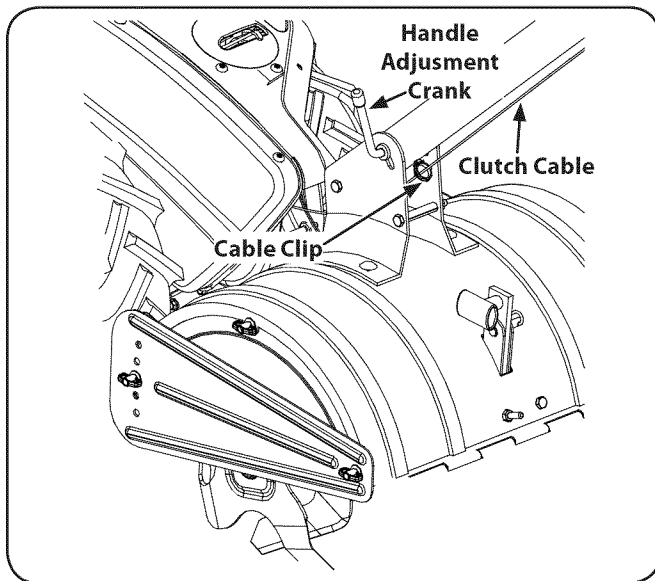

Figure 3-7

2. Remove one hex nut from the threaded casing on the end of the cable. Slip the wire up through the slot on the cable bracket underneath the handle.
3. Push the end of the casing up through the cable bracket. Rethread the hex nut on the end of the cable. Do not tighten at this time.

4. Pull the cable upwards to obtain slack and hook the Z-connector at the end of the cable into the bracket on the clutch control (beneath the handle panel). Tighten the nut against the cable bracket. See Fig. 3-8.

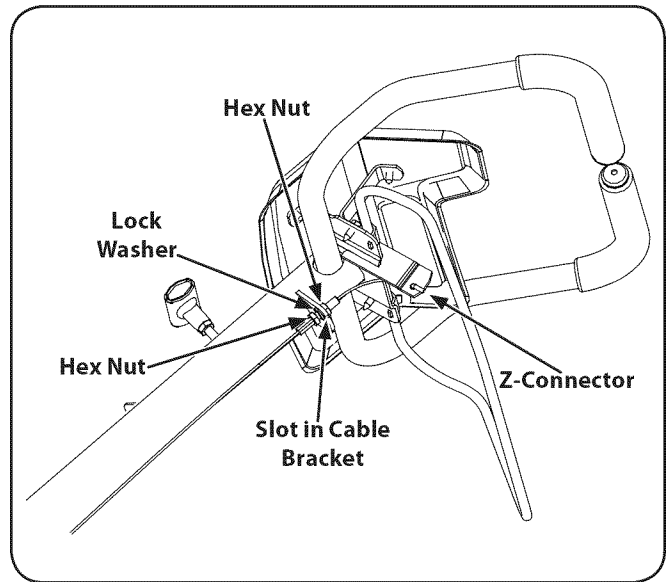

Figure 3-8

NOTE: Do not overtighten the clutch cable. Too much tension may cause it to break.

Adjustments

Clutch Cable

NOTE: Service the engine with oil and gasoline before checking this adjustment. Refer to the separate Engine Operator's Manual packed with your tiller for instructions.

1. Position the tiller so that the front counterweight is against a solid object, such as a wall. With the gear selection lever in NEUTRAL, start the engine. Refer to the Operation Section for starting instructions.

NOTE: Keep hands out of the belt area while the tiller is operating.

2. Standing on the right side of the tiller, visually examine the belt (inside the belt cover). It should not be turning.
3. If the belt turns with the machine in neutral, adjust it by moving the hex nut below the cable bracket down a few turns. Tighten the upper hex nut against the bracket. See Fig. 3-8.
4. Now move the shift lever to the FORWARD (Wheels Forward) position. Carefully engage the clutch by squeezing the clutch handle against the handle. The wheels should now spin.
5. If the wheels do not rotate with the tiller in forward, adjust by turning the hex nut found above the cable bracket up a few turns. Tighten the bottom hex nut against the bracket. Re-check both adjustments, and readjust as necessary. Make certain that the hex nuts at the cable bracket are tight. Do not overtighten the clutch cable.

NOTE: If additional adjustment is required, it may be necessary to remove the belt cover and move the hex nuts at the other end of the clutch cable to increase the belt tension.

Set-Up

Tires

The tires on your tiller may be over-inflated for shipping purposes. Reduce the tire pressure before operating. The recommended operating tire pressure is approximately 14 p.s.i. on 14 inch tires. Check the sidewall of tire for tire manufacturer's recommended pressure.



WARNING! Maximum tire pressure under any circumstances is 30 p.s.i. Equal tire pressure should be maintained on both tires.

Gas & Oil Fill-Up

Service the engine with gasoline and oil as instructed in the separate Engine Operator's Manual packed with your tiller. Read the instructions carefully.



WARNING! Use extreme care when handling gasoline. Gasoline is extremely flammable and the vapors are explosive. Never fuel the machine indoors or while the engine is hot or running.

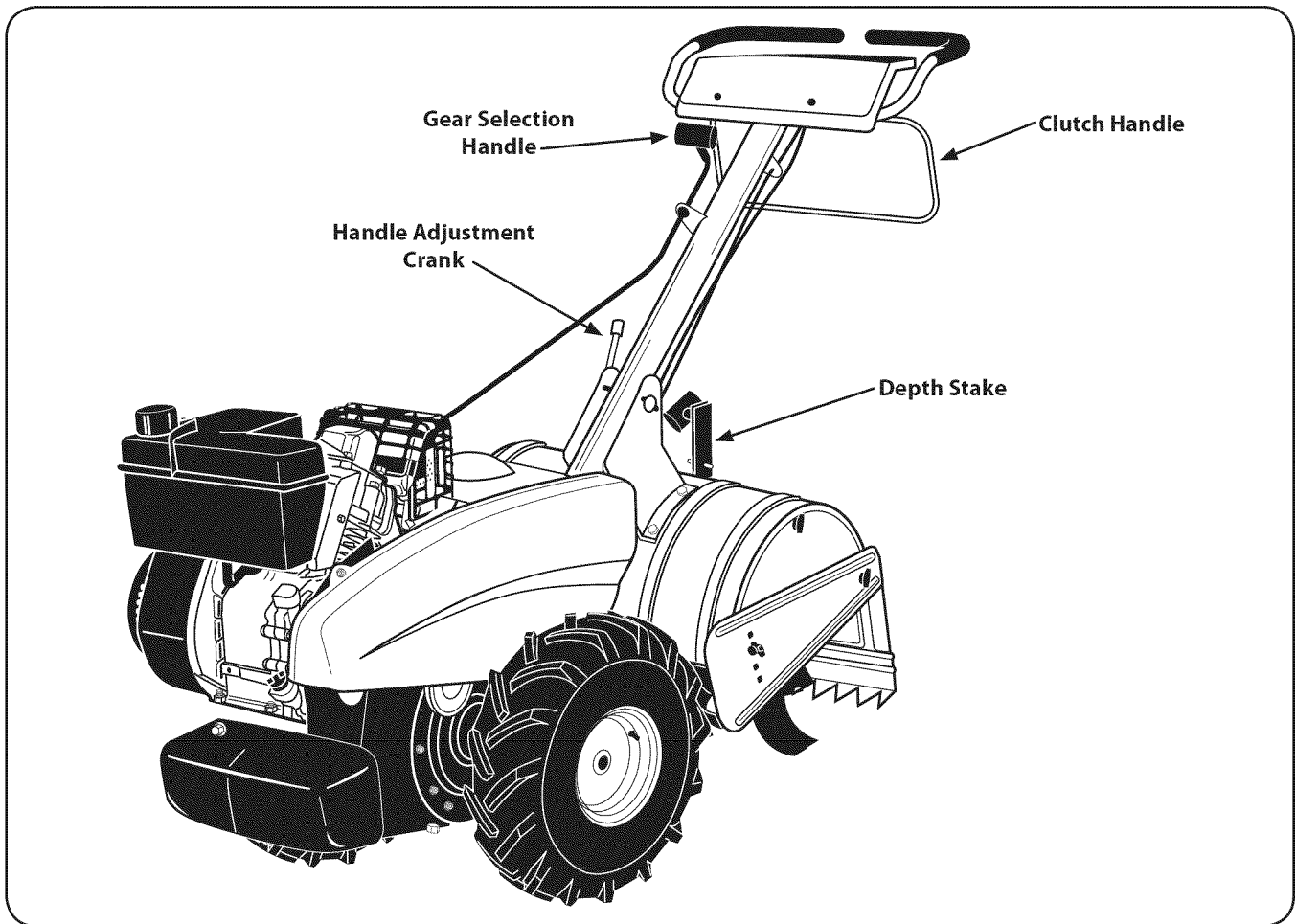

Figure 4-1

Engine Controls

See the separate Engine Operator's Manual for additional information and functions of the engine controls.

Gear Selection Handle

The gear selection handle is located on the front of the handle assembly. It is used to select NEUTRAL, REVERSE, or one of the FORWARD modes.

Clutch Handle

The clutch handle is located beneath the handle. Squeezing the clutch handle against the handle engages the wheel and tine drive mechanisms.

Throttle Control

The throttle control lever is located on the engine. It controls the engine speed and stops the engine.

Choke Lever (If equipped)

The choke lever is used to enrich the fuel mixture in the carburetor when starting a cold engine.

Primer (If equipped)

The primer is used when starting a cold engine.

Depth Stake

The depth stake controls the tilling depth.

Handle Adjustment Crank

The handle may be adjusted to the height desired.

Fuel Shut-Off Valve (If equipped)

Make sure the valve is in the ON (horizontal) position when starting the engine. Any time the tiller is not in operation (i.e., storing, performing maintenance or adjustment), make sure the valve is in the OFF (vertical) position.

Starting the Engine



WARNING! Read, understand, and follow all instructions and warnings on the machine and in this manual before operating.

NOTE: When pushing the machine with the engine off, you will hear a ratcheting-gear sound coming from the tiller's chain case. This is normal.



WARNING! Be sure that no one is standing in front of the tiller while the engine is running or being started.

1. Place the gear selection lever in NEUTRAL.
2. Place the throttle control lever in the FAST position or if equipped, place the engine speed control in the START position.
3. Move the choke lever to the CHOKE position or, if equipped, push the primer two (2) or three (3) times. Wait about two (2) seconds between each push.

NOTE: A warm engine may not require choking or priming.
1. Stand at side of tiller. Grasp the starter handle and pull out slowly, until it pulls slightly harder. Let the rope recoil slowly.
2. Pull the starter handle rapidly. Do not allow the handle to snap back. Allow it to recoil slowly while keeping a firm hold on the starter handle.
3. Repeat the previous steps until the engine starts.
4. As the engine warms up and begins to operate evenly, move the choke lever gradually to the RUN position. If the engine falters, return to the choke position, then slowly move to the RUN position.

NOTE: See the Engine Operator's Manual packed with your tiller for more detailed instructions.

Stopping the Engine

To stop the engine, move the throttle control to the STOP or OFF position.

Setting the Depth

Tilling depth is controlled by the depth stake which can be adjusted to five different settings. Adjust the side shields as you adjust the depth stake.



WARNING! Always disconnect the spark plug wire and ground it against the engine, before performing any adjustments.

1. When using the tiller for the first time, use the second adjustment hole from the top (1" of tilling depth). See Fig. 5-1.

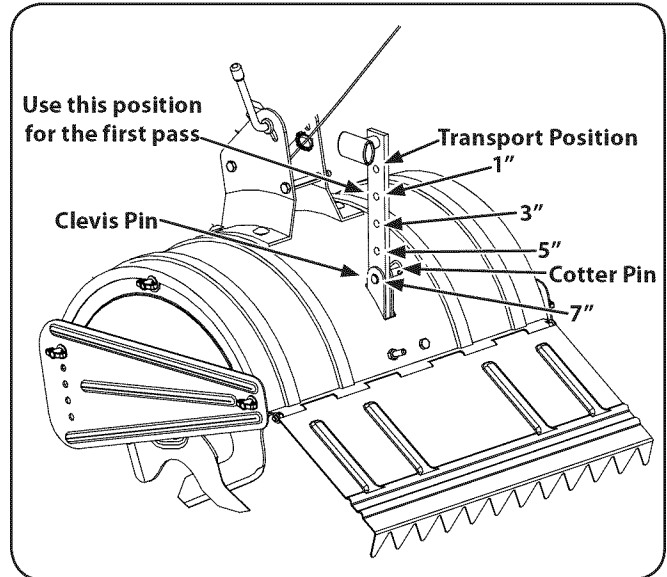

Figure 5-1

2. To adjust the depth stake, remove the clevis pin and cotter pin. Move the depth stake to the desired setting and secure with the clevis pin and cotter pin. See Fig. 5-1.
3. When breaking up sod and for shallow cultivation, use the setting which gives 1" of tilling depth (the second hole from the top). Place the side shields in their lowest position.
4. To adjust the side shields, remove the wing nuts. Move the side shield to the desired position and replace the wing nuts. Tighten securely. See Fig. 5-2.

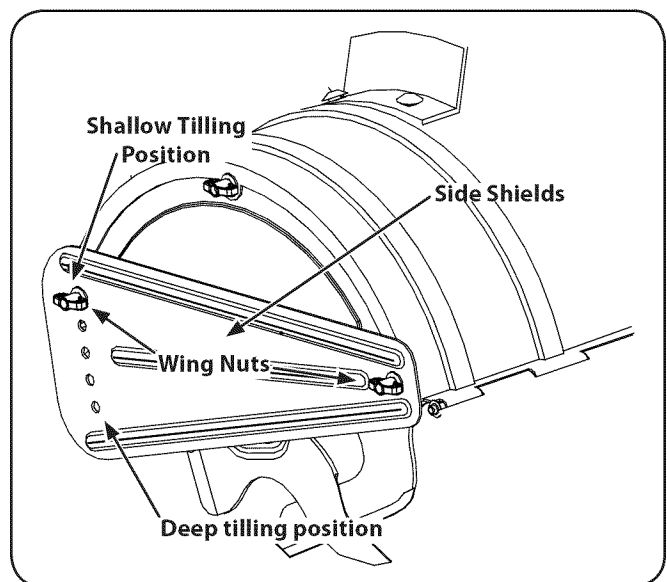

Figure 5-2

5. For further depth, raise the depth stake and side shields and also make one or two more passes over the area.
6. When tilling loose soil, the depth stake may be raised to its highest position by using the bottom adjustment hole to give the deepest tilling depth. Raise the side shields to the highest position.
7. To transport the tiller, lower the depth stake by using the top adjustment hole.

Operating the Tiller

1. Select the depth stake setting.
2. Start the engine as instructed in the Engine Operator's Manual.
3. Move the gear selection handle to one of the forward modes or reverse.



WARNING! Do not move the gear selection handle with the wheels or tines engaged. Make certain the tiller is stopped completely before changing the gear selection. A partial engagement may be necessary when engaging the tines.

4. Squeeze the clutch handle against the handle to engage the wheels and tines.

NOTE: Make certain the gear selection indicator is correctly positioned before engaging the clutch handle. If it is between gears, the engine will stall.

5. To transport the tiller, do not engage the tines. Select the wheel drive only.



WARNING! Do not push down on the handles so that the wheels are lifted off the ground while using the tine drive, or the tiller could move backward and cause personal injury.

6. For the best results, it is recommended that the garden be tilled twice (lengthwise, then widthwise) to thoroughly pulverize the soil.



WARNING! Disconnect the spark plug wire and ground it against the engine before performing any maintenance or repairs.

Maintenance

Engine

Refer to the separate Engine Operator's Manual for engine maintenance instructions.

Tires

Recommended operating tire pressure is approximately 14 p.s.i. on 14 inch tires. (Check the sidewall of the tire for the manufacturer's recommended pressure). Maximum tire pressure under any circumstances is 30 p.s.i. Equal tire pressure should be maintained on both tires.



WARNING! Excessive pressure (over 30 p.s.i.) when seating beads may cause tire/rim assembly to burst with force sufficient to cause serious injury.

Air Cleaner

Service the air cleaner every 10 hours under normal conditions. Clean it every hour under extremely dusty conditions. Poor engine performance or flooding usually indicates that the air cleaner should be serviced. Refer to the Engine Operator's Manual for maintenance instructions.

Spark Plug

The spark plug should be cleaned and the gap reset every 25 hours of engine operation. Spark plug replacement is recommended at the start of each tiller season; check the Engine Operator's Manual for the correct plug type and gap specification.

Lubrication

Transmission

The transmission is pre-lubricated and sealed at the factory. It requires no checking unless the transmission is disassembled. To fill with grease, lay the right half of the transmission on its side, add 22 ounces of Benalene 920 grease, and assemble the left half to it. This grease can be obtained at your nearest authorized dealer by ordering part number 737-0300A.

Clutch Handle

Lubricate the pivot point on the clutch handle and the cable at least once a season with light oil. The control must operate freely in both directions.

Pivot Points

Lubricate all the pivot points and linkages at least once a season with light oil.

Tine Shafts

Remove the tine assemblies and lubricate the tine shafts at least once a season.

Wheel Shafts

Remove the wheel assemblies and lubricate the axle shafts at least once a season.

Adjustments



WARNING! Never attempt to make any adjustments while the engine is running, except where specified in the Operator's Manual.

Handle Adjustment

The handle may be adjusted to the desired height. Refer to the Controls & Features Section for details.

Belt Tension Adjustment

Periodic adjustment of the belt tension may be required due to normal stretch and wear on the belt. Adjustment is needed if the tines or wheels seem to hesitate while turning, but the engine maintains the same speed. To adjust the tension on the belt, refer to the Assembly & Set-Up Section for instructions.

Engine Adjustment

Refer to the separate Engine Operator's Manual for engine adjustment instructions.

Off-Season Storage

If the tiller will not be used for a period longer than 30 days, the following steps should be taken to prepare the tiller for storage.

- Clean the exterior of the engine and the entire tiller thoroughly. Lubricate the tiller as described in the lubrication instructions.
- The use of a pressure washer to clean your tiller is not recommended. The washer may cause damage to electric components, spindles, pulleys, bearings or the engine. The use of pressure washers will result in shortened life and reduce serviceability.
- Refer to the Engine Operator's Manual for the correct engine storage instructions.
- Wipe the tines with an oiled rag to prevent rust.
- Store the tiller in a clean, dry area. Do not store next to corrosive materials, such as fertilizer.

NOTE: When storing any type of power equipment in an unventilated or metal storage shed, care should be taken to rustproof the equipment. Using a light oil or silicone, coat the equipment and especially any springs, bearings, and cables.

Belt Replacement

Your tiller has been engineered with a belt designed for long life and optimal performance. It should never be replaced with a non-OEM belt. Order all belts through an authorized service dealer or by contacting Customer Support as instructed on page 2.

Refer to Fig. 7-1 for the following steps.

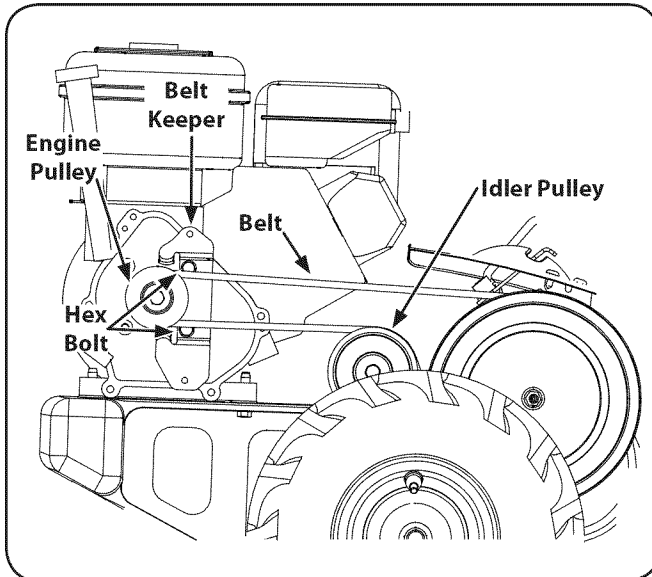
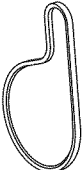
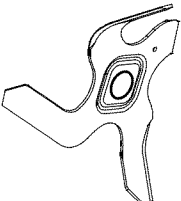

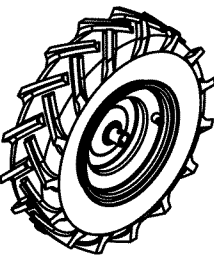
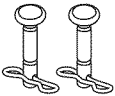
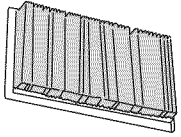
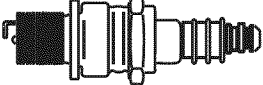

Figure 7-1

1. Disconnect and ground the spark plug wire against the engine.
2. Remove the belt cover from the left side of the tiller by removing the two torx head screws from the top of the belt cover.
3. Remove the two hex cap nuts and flat washers from the front side of the belt cover. Remove the hex nut and flat washer at the back of the cover.
4. Remove the belt keeper assembly located behind the engine pulley by removing two hex bolts and lock washers.
5. Remove the belt and reassemble the new belt. Follow the instructions in reverse order.

NOTE: Upon reassembly, make certain the belt is routed over the idler pulley and inside of belt keepers by engine pulley. See Fig. 7-1.

Problem	Cause	Remedy
Engine fails to start	<ol style="list-style-type: none"> 1. Fuel tank empty, or stale fuel. 2. Throttle control lever not in correct starting position (if equipped). 3. Blocked fuel line. 4. Dirty air cleaner. 5. Choke not in ON position. 6. Spark plug wire disconnected. 7. Faulty spark plug. 8. Engine flooded. 	<ol style="list-style-type: none"> 1. Fill tank with clean, fresh gasoline. 2. Move throttle lever to start position. 3. Clean fuel line. 4. Refer to the Engine Operator's Manual 5. Move switch to ON position. 6. Connect wire to spark plug. 7. Clean, adjust gap or replace. 8. Refer to the Engine Operator's Manual
Engine runs erratic	<ol style="list-style-type: none"> 1. Tiller running on CHOKE. 2. Spark plug wire loose. 3. Blocked fuel line or stale fuel. 4. Vent in gas cap plugged. 5. Water or dirt in fuel system. 6. Dirty air cleaner. 7. Carburetor out of adjustment. 	<ol style="list-style-type: none"> 1. Move choke lever to OFF position. 2. Connect and tighten spark plug wire. 3. Clean fuel line; fill tank with clean, fresh gasoline. 4. Clear vent. 5. Drain fuel tank. Refill with fresh fuel. 6. Refer to the Engine Operator's Manual 7. Refer to the Engine Operator's Manual
Engine overheats	<ol style="list-style-type: none"> 1. Engine oil level low. 2. Dirty air cleaner. 3. Air flow restricted. 4. Carburetor not adjusted properly. 	<ol style="list-style-type: none"> 1. Fill crankcase with proper oil. 2. Refer to the Engine Operator's Manual 3. Refer to the Engine Operator's Manual 4. Adjust carburetor as instructed in the Engine Operator's Manual
Tines do not engage	<ol style="list-style-type: none"> 1. Foreign object lodged in tines. 2. Tine clevis pin(s) missing. 3. Pulley and idler not in correct adjustment. 4. Not shifting properly. 5. Control cable not adjusted properly. 6. Belt worn and/or stretched. 	<ol style="list-style-type: none"> 1. Dislodge foreign object. 2. Replace tine clevis pin(s). 3. Take tiller to authorized service dealer. 4. Refer to the Operation Section for proper shifting procedures. 5. Adjust control cable 6. Replace belt.
Tines skip over ground	<ol style="list-style-type: none"> 1. Improper rotation. 	<ol style="list-style-type: none"> 1. Forward rotation should only be used on soil that has already been tilled, not on virgin soil.
Wheels do not engage	<ol style="list-style-type: none"> 1. Clevis pin missing. 2. Tiller is not being shifted properly. 3. Control cable not adjusted properly. 4. Belt worn and/or stretched. 	<ol style="list-style-type: none"> 1. Replace clevis pin. 2. Refer to Operation Section for proper shifting procedures. 3. Adjust control cable 4. Replace belt.

Component	Part Number and Description
	754-0434 V-Belt, ½ x 51.17
	742-0547 Outer Tine (LH) 742-0545 Inner Tine (LH) 742-0456 Outer Tine (RH) 742-0545 Inner Tine (RH)
	746-0916 Clutch Cable
	634-04233 Tires, 14 X 4-½ X 6
	714-0419B Cotter Pin, Tine Assembly 711-0415 Clevis Pin, Tine Assembly 714-0147 Cotter Pin, Depth Stake 711-0415 Clevis Pin, Depth Stake
	BS-491588 Air Filter
	759-3336 Champion RC12YC

Phone (800) 800-7310 or (330) 220-4683 to order replacement parts or a complete Parts Manual (have your full model number and serial number ready). Parts Manual downloads are also available free of charge at www.mtdproducts.com.

MANUFACTURER'S LIMITED WARRANTY FOR



The limited warranty set forth below is given by MTD LLC with respect to new merchandise purchased and used in the United States and/or its territories and possessions, and by MTD Products Limited with respect to new merchandise purchased and used in Canada and/or its territories and possessions (either entity respectively, "MTD").

"MTD" warrants this product (excluding its *Normal Wear Parts and Attachments* as described below) against defects in material and workmanship for a period of two (2) years commencing on the date of original purchase and will, at its option, repair or replace, free of charge, any part found to be defective in materials or workmanship. This limited warranty shall only apply if this product has been operated and maintained in accordance with the Operator's Manual furnished with the product, and has not been subject to misuse, abuse, commercial use, neglect, accident, improper maintenance, alteration, vandalism, theft, fire, water, or damage because of other peril or natural disaster. Damage resulting from the installation or use of any part, accessory or attachment not approved by MTD for use with the product(s) covered by this manual will void your warranty as to any resulting damage.

Normal Wear Parts are warranted to be free from defects in material and workmanship for a period of thirty (30) days from the date of purchase. Normal wear parts include, but are not limited to items such as: batteries, belts, blades, blade adapters, tines, grass bags, wheels, rider deck wheels, seats, snow thrower skid shoes, friction wheels, shave plates, auger spiral rubber and tires.

Attachments — MTD warrants attachments for this product against defects in material and workmanship for a period of one (1) year, commencing on the date of the attachment's original purchase or lease. Attachments include, but are not limited to items such as: grass collectors and mulch kits.

HOW TO OBTAIN SERVICE: Warranty service is available, WITH PROOF OF PURCHASE, through your local authorized service dealer. To locate the dealer in your area:

In the U.S.A.

Check your Yellow Pages, or contact MTD LLC at P.O. Box 361131, Cleveland, Ohio 44136-0019, or call 1-800-800-7310, 1-330-220-4683 or log on to our Web site at www.mtdproducts.com.

In Canada

Contact MTD Products Limited, Kitchener, ON N2G 4J1, or call 1-800-668-1238 or log on to our Web site at www.mtdcanada.com.

This limited warranty does **not** provide coverage in the following cases:

- The engine or component parts thereof. These items may carry a separate manufacturer's warranty. Refer to applicable manufacturer's warranty for terms and conditions.
- Log splitter pumps, valves, and cylinders have a separate one-year warranty.

- Routine maintenance items such as lubricants, filters, blade sharpening, tune-ups, brake adjustments, clutch adjustments, deck adjustments, and normal deterioration of the exterior finish due to use or exposure.
- Service completed by someone other than an authorized service dealer.
- MTD does not extend any warranty for products sold or exported outside of the United States and/or Canada, and their respective possessions and territories, except those sold through MTD's authorized channels of export distribution.
- Replacement parts that are not genuine MTD parts.
- Transportation charges and service calls.
- MTD does not warrant this product for commercial use.

No implied warranty, including any implied warranty of merchantability or fitness for a particular purpose, applies after the applicable period of express written warranty above as to the parts as identified. No other express warranty, whether written or oral, except as mentioned above, given by any person or entity, including a dealer or retailer, with respect to any product, shall bind MTD. During the period of the warranty, the exclusive remedy is repair or replacement of the product as set forth above.

The provisions as set forth in this warranty provide the sole and exclusive remedy arising from the sale. MTD shall not be liable for incidental or consequential loss or damage including, without limitation, expenses incurred for substitute or replacement lawn care services or for rental expenses to temporarily replace a warranted product.

Some states do not allow the exclusion or limitation of incidental or consequential damages, or limitations on how long an implied warranty lasts, so the above exclusions or limitations may not apply to you.

In no event shall recovery of any kind be greater than the amount of the purchase price of the product sold. **Alteration of safety features of the product shall void this warranty.** You assume the risk and liability for loss, damage, or injury to you and your property and/or to others and their property arising out of the misuse or inability to use the product.

This limited warranty shall not extend to anyone other than the original purchaser or to the person for whom it was purchased as a gift.

HOW STATE LAW RELATES TO THIS WARRANTY: This limited warranty gives you specific legal rights, and you may also have other rights which vary from state to state.

IMPORTANT: Owner must present Original Proof of Purchase to obtain warranty coverage.

**MTD LLC, P.O. BOX 361131 CLEVELAND, OHIO 44136-0019; Phone: 1-800-800-7310, 1-330-220-4683
MTD Canada Limited - KITCHENER, ON N2G 4J1; Phone 1-800-668-1238**