

# MANUAL

## AMBrC system

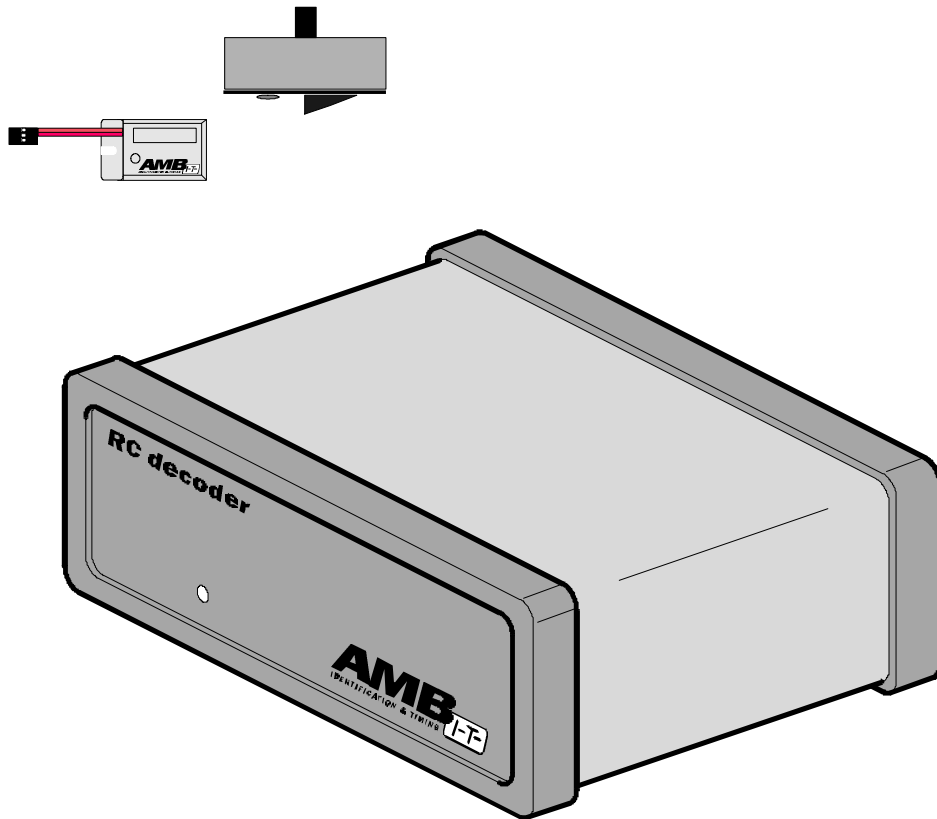

## Contents

	Page
1. INTRODUCTION .....	2
2. INSTALLATION OF THE DETECTION LOOP .....	4
3. INSTALLATION OF THE AMBRC DECODER .....	11
4. INSTALLATION OF THE DIRECT POWERED TRANSPONDER .....	14
5. INSTALLATION OF THE RECHARGEABLE TRANSPONDER .....	15
6. CHARGING THE TRANSPONDER .....	16
7. OPERATING THE SYSTEM / TROUBLE SHOOTING.....	17
8. TECHNICAL SPECIFICATIONS.....	19
9. EC AND FCC REGULATIONS.....	20

AMB i.t.

Manual number: AMBrc/Rev. 1.1d

**All rights reserved**

This publication is to be used for the standard model of the product of the type given on the cover page. This publication has been written with great care. However, the manufacturer cannot be held responsible, either for any errors occurring in this publication or for their consequences.

CE 0122 ①

## 1. Introduction

The AMBrc system is specially designed to time and score RC model car races. The signal sent by an AMBrc transponder mounted on each RC model car is picked up by the detection loop, which is installed in the track. This detection loop is connected to the AMBrc decoder, via a coax cable. The decoder timestamps the received transponder signals and sends this data via a RS232 cable to a connected computer. The decoder is powered by a 12V mains adapter. Two types of transponders are available: a battery powered transponder and a direct powered transponder. These transponders each generate a unique number, which enables you to identify each RC car on the track. An AMBrc transponder is always active when charged or powered by the RC car receiver (in case of the direct powered transponder).

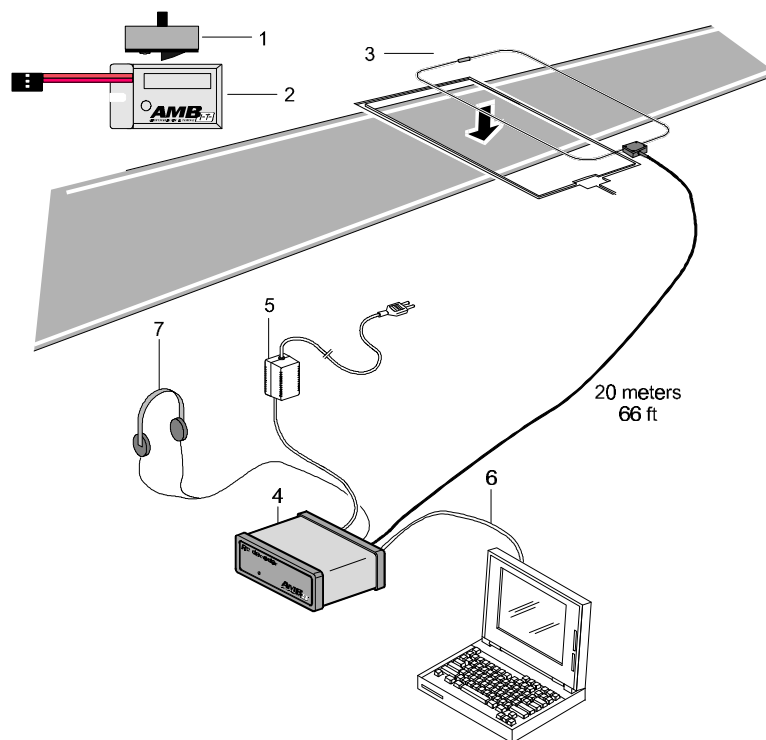

### System components

1. AMBrc rechargeable transponder (part number 1301)
2. AMBrc direct powered transponder (part number 1302)
3. Detection loop, coax cable and connection box(part number 4701)
4. AMBrc decoder (part number 3301)
5. Adapter for AMB decoder (part number 6501)
6. Connection cable RS232 (part number 6201)
7. Headphones for decoder (part number 6701)

Not in picture: charger rack (part number 2421)

## 2. Installation of the Detection loop

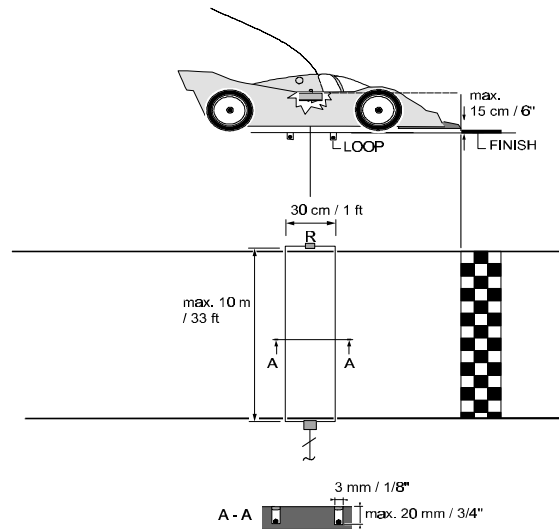

The AMB detection loop is made of a special water-resistant wire to guarantee durability and has the resistor already installed. Keep the resistor opposite to the connection box (the box that connects the coax cable to the loop).

Loops installed in re-enforced concrete may suffer from a noticeable loss of sensitivity (less reach of the transponders) especially at wider tracks, since the steel underneath the loop forms short-circuited loops. This weakens the signal from the loop. If unavoidable, put the loop where the track is the least wide and put the loop wire in no deeper than necessary.

Installing the loop:

1. The detection loop must be positioned in such a way that the transponder is in the middle of the two loop wires when the front of the RC model car is above the finish line. If there is a possibility of RC model cars running outside the track, you may need to extend the loop, but at all times keep the loop within 10 m / 33ft maximum width. Keep the extensions as short as possible.
2. Cut the slots in the track **maximum 2 cm / 3/4" deep** and **30 cm / 1 ft apart**, with a suitable cutting disc/saw. To ensure one hundred percent detection, make sure RC model cars can not pass outside the detection loop.
3. Put the wires of the detection loop in the slots and cut the excess length of the detection loop wires.
4. Put the heat shrinkage sleeves over both of the detection loop wire ends. **Solder** the wire ends to the short wires of the connection box. Put both the shrinkage sleeves over the solder connections and shrink them by holding them over a heat source.
5. Fill the slot with silicon. Make sure the silicon is fully under the surface of the track, otherwise the tires may pull out the silicone. For OFF-ROAD use cover the loop with carpet or similar. The carpet can be covered with sand.
6. The detection loop is sensitive to interference, possibly emitted by nearby cables. To avoid possible interference keep all cables 3 m / 10 ft or more away.

7. All loop wires must be installed according to the drawing in order to avoid a serious degradation in performance (excess loop wire must be cut).
8. As the reach of AMBrc loop can be up to 90 cm / 3", especially when the noise (interference) level is low, transponders on other parts of the track should not be able to get closer to the loop than 90cm / 3".
9. If the coax cable from the loop to the decoder has to pass underneath the track (pit lane), please make sure the coax cable is at least 2,5 cm / 1" underneath the track, to avoid detection of passing transponders over the cable.

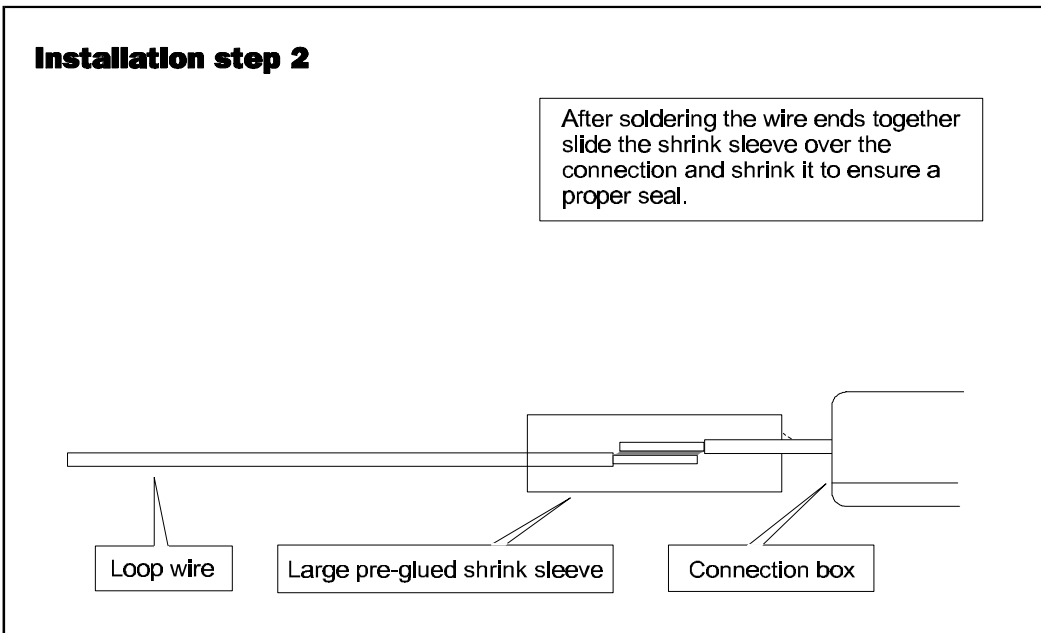
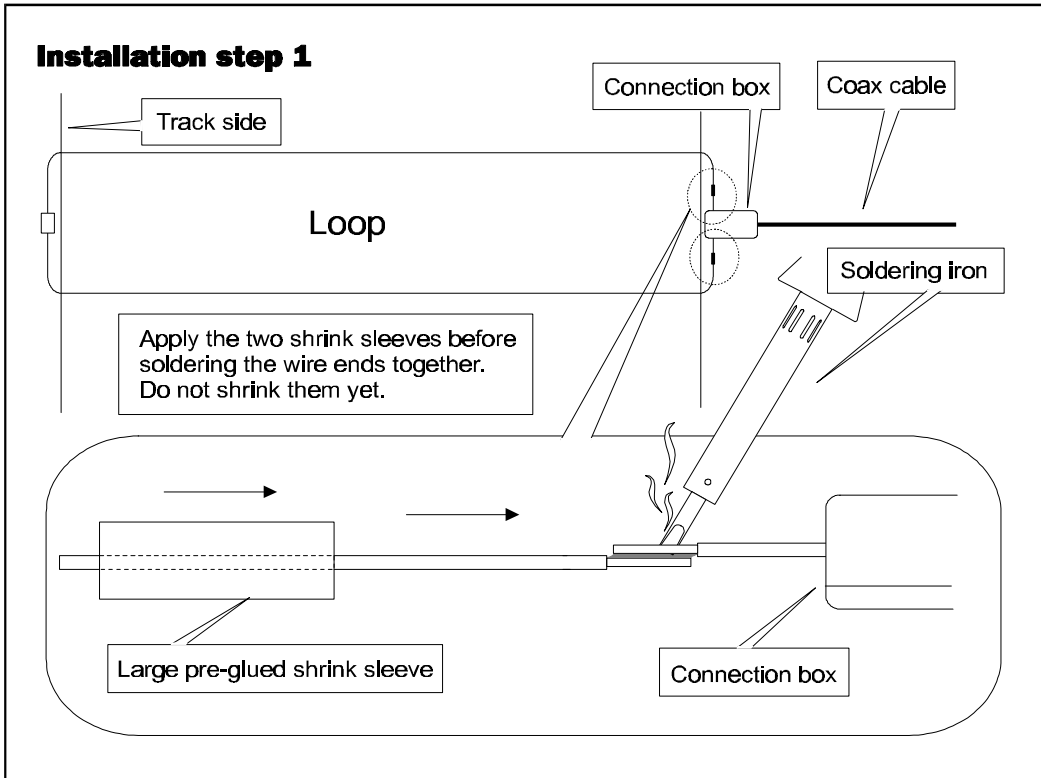

## Loop installation for temporary tracks.

In some situations it may not be possible to have the detection loop installed permanently in the track. This can be the case with temporary tracks, like indoor race events and parking lot racing. In that case a detection loop installed on a bridge can be used. **Do not make this bridge of any type of metal or carbon fiber, as these materials will highly reduce the sensitivity of the loop, resulting in far less reach of the transponder.**

For temporary loop installations, the loop wires may be connected to the connection box wires with help of a good quality connector such as a terminal block. (Please note that bad connections in a loop or coax connections are by far the most frequent cause of substandard performance). For temporary loops any wire similar to the AMB loop wire can be used. Opposite to the connection box a resistor of 470-ohm (0.15-1 watt) must be installed. For best results please solder all joints and insulate well. For outdoor soldering a propane fired soldering iron works best.



*Jeff Blackburn's loop bridge used in the HPI Challenge race, Castle Hobbies of San Jose, CA*

When using a bridge make sure the detection loop has a width of 45 cm / 1.5 ft. The bridge should cover the track width and no RC model cars should be able to pass outside the bridge. The connection box must be mounted on top of the bridge in order to avoid loose detection wires, which can cause interference. At all times, keep all wiring as short as possible. Construct the bridge with sufficient rigidity so it can withstand crashes from a RC model car. To make sure the received transponder signal is strong enough, the distance between the bridge and the track may not be more than 45 cm / 1.5 ft. Preferably keep the height of the loop on the bridge as low as possible.

Compared to the in-track loop, the downside of a bridge is the greater distance between the passing transponder and the detection loop resulting in a weaker signal for the decoder.

At sundown and at night, the interference from short wave radio signals intensifies strongly and may occasionally cause the transponder signals get swamped by the interference. To prevent this from occurring it is advisable to keep the bridge as short (less than 3 m / 10 ft) and low as possible (less than 45 cm / 1.5 ft).





## Speed measurement and split time

For speed measurements two loops have to be installed at an exact distance of 10 m / 33ft of each other at the fastest point of the track. For split time, the second loop can be installed at any desired measure point of the track. **Whenever using two loops the maximum width that can be used is 5 m / 16.5 ft per loop.** Via an AMB coax splitter and extra coax cable (part numbers 6704 and 6001/6002/6003) the two loops are connected to the AMBrc decoder. Using two loops will result in a weaker signal for the connected decoder. If very high noise (interference) levels occur, as may happen at night, the speed or split-time loop may have to be disconnected.

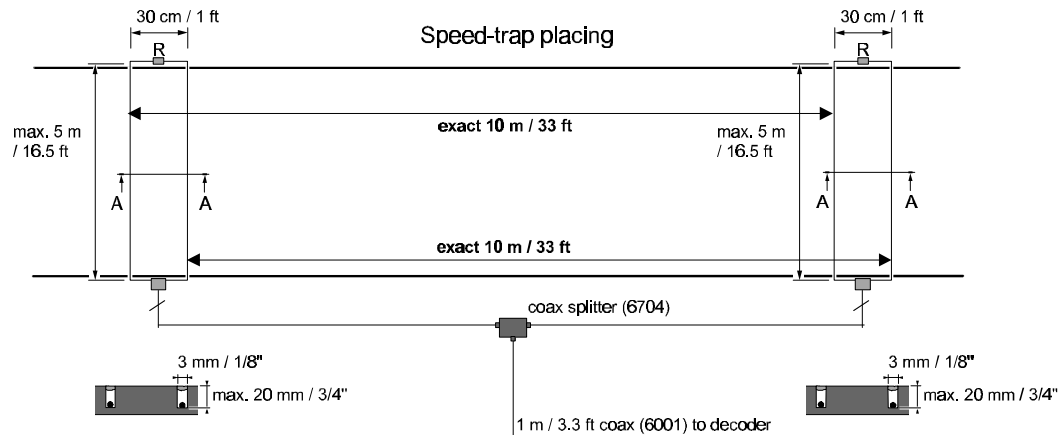

*Loop installation for speed trap setup.*

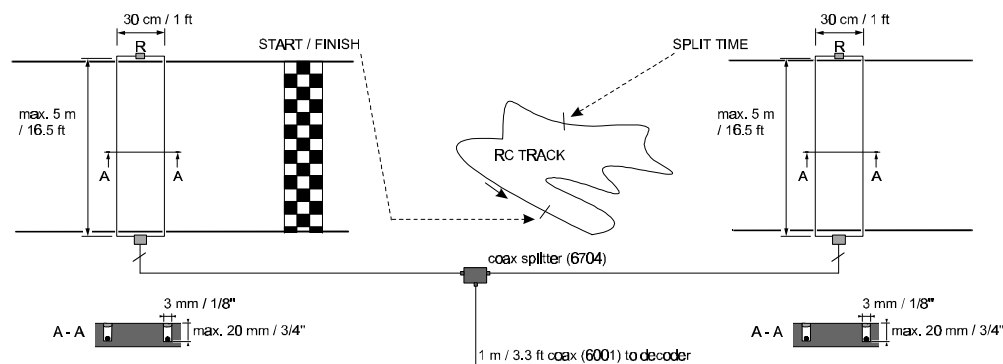

*Loop installation for split time setup*

As the AMBrc decoder can not distinguish between transponder signals coming from the finish, speed or split time loop, permanent manual supervision is necessary. For instance, when a car stops in between the two loops used for the speed trap for longer than the minimum lap time set in the software, the software will add a lap when the car passes the second speed loop. The best way to avoid this is to use a decoder for the finish line and a

second decoder for the speed and/or split time loop. Special designed software is necessary.

For speed measurements the AMBrc decoder has to be set into speed-trap mode with the help of specially designed (AMB) software. The speed-trap mode is indicated on the AMBrc decoder by rapid flashing of the green LED on the front panel. In speeds trap mode the decoder detects the same transponder again after 0.2 seconds instead of the standard 2 seconds.

### 3. Installation of the AMBrc decoder

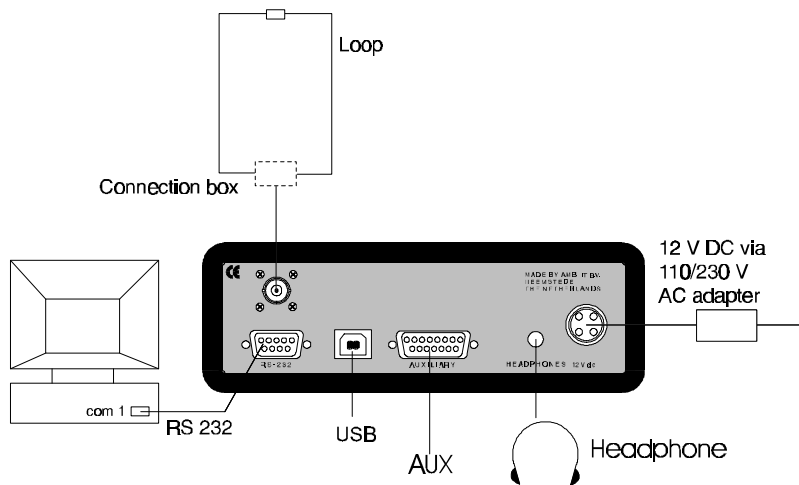

**Shielded cables:** All cables, as supplied by AMB, including the headphones cable, are properly shielded. The use of inferior or unshielded cables may deteriorate the level of unwanted radiation and may increase the sensitivity to outside interference. Therefore use only good quality shielded cables.

**The decoder is a precision instrument. Please handle it with care and keep the decoder out of direct sunlight and humidity.**

1. Connect the 75-Ohm double shielded coax cable to the AMBrc decoder. Keep the coax cable at least 30 cm / 1 ft away from other cables to avoid interference.
2. Connect the RS232 cable between the AMBrc decoder and the RS232 port of the computer (a straight pin to pin RS232 connection cable is needed, such as AMB part number 6201). Connect the headphone. A beep will sound for every passing transponder providing an easy check on proper operation.
3. Connect the 12V adapter to the decoder and mains.
4. To use the opto coupled inputs (for instance for a photocell) or the opto coupled outputs, connect it using the scheme and table below. The synchronized input, which is identical to the photocell input, enables you to synchronize multiple decoders running. Both photocell and sync. input need a 4-12 VDC (5-15 mA) power source. Pins 8 and 15 may be used for this purpose, but for reasons of possible interference an external power source is preferred (i.e. 9V battery).

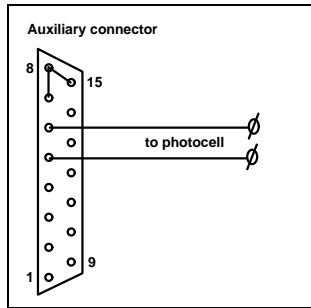

	Pin	Signal
<b>Power Supply</b>	8+15	4.5 V 50 mA
<b>Opto coupled inputs</b>	5	ground
	6	opto 1 - input
	7	opto 1 + input
	12	opto 2 - input
	13	opto 2 + input
<b>Sync input</b>	1+9	Ground
	10	Sync - input
	11	sync + input
<b>Opto output</b>	4	opto 1 - output
	14	opto 1 + output
	2	opto 2 - output
	3	opto 2 + output

The opto outputs are under software control and may be used to drive electronics that may be used for start lights. The opto outputs are connected to the transistor in the opto coupler, the + is connected to the collector and the - to the emitter of the transistor. Maximum allowed current through the transistor is 10mA.

The AMBrc decoder is equipped with a USB interface which is for future use, but it can currently be used to get power from a connected (laptop) computer. In that case you may also use the 12VDC power input for backup power.

The AMBrc decoder receives the signal of each passing transponder and combines the transponder number with the exact passing time. The decoder sends the information to a computer on which (AMB) timing software is running.

An easy check on proper operation of each passing transponder is done with help of a headphone, since every transponder passing generates a “beep” signal.

At power-up the AMBrc decoder will beep 3 times and gives AMB20 compatible output to support AMB20 software. AMBrc software will trigger the AMBrc decoder for AMBrc output.



#### 4. Installation of the Direct Powered Transponder

The transponder must be mounted **horizontally** at all times, preferably inside the RC model car. The position of the transponder must be identical in all RC model cars competing in the race.

Transponders may not be positioned more than **15 cm / 6"** away from the detection loop, with no metal or carbon fiber in-between. It is preferable to mount the transponder as close as possible to the detection loop. Make sure the transponder can not get detached during a race.

To mount the direct powered transponder a nut and bolt can be used. Double-sided sticky tape can be used, but this is not advised when liquid fuels are used in RC model cars. Locate the direct powered transponder in your RC model car in such way that it has a free view at the detection loop. Keep the power wire neat and tidy in the RC model car so it can not give you any trouble while driving the RC model car.

The power connector is a standard servo plug. This servo plug can be connected to a free channel of the radio receiver. This channel can be a 3<sup>rd</sup> channel or battery channel. When no free channel is available a Y-splitter servo wire can be used to connect the direct powered transponder to your radio receiver. Your local hobby store can provide you with a Y-splitter servo wire if necessary.

If the polarity of the servo plug does not match the polarity of the radio receiver, you can change this (red wire is +). This is done by very carefully lifting the plastic lugs of the servo plug with a hobby-knife (be careful not to cut yourself). When the plastic lugs are lifted you can very carefully remove the connectors from the plug. Reinstall the connectors into plug according to the polarity of the radio receiver you use. Push the plastic lugs **very carefully** back into the servo plug and make sure the connectors are fully seated into the plug.

Whenever power is applied to the radio receiver, the direct powered transponder will show a green LED on both sides. These green LEDs indicate that the direct powered transponder is working.

Make sure the transponder can not get detached during a race.

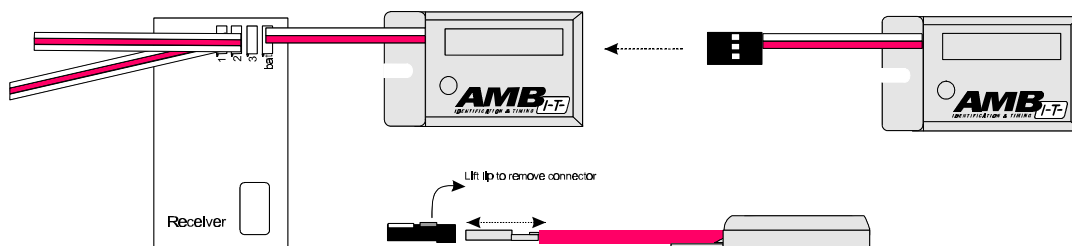

## 5. Installation of the rechargeable transponder

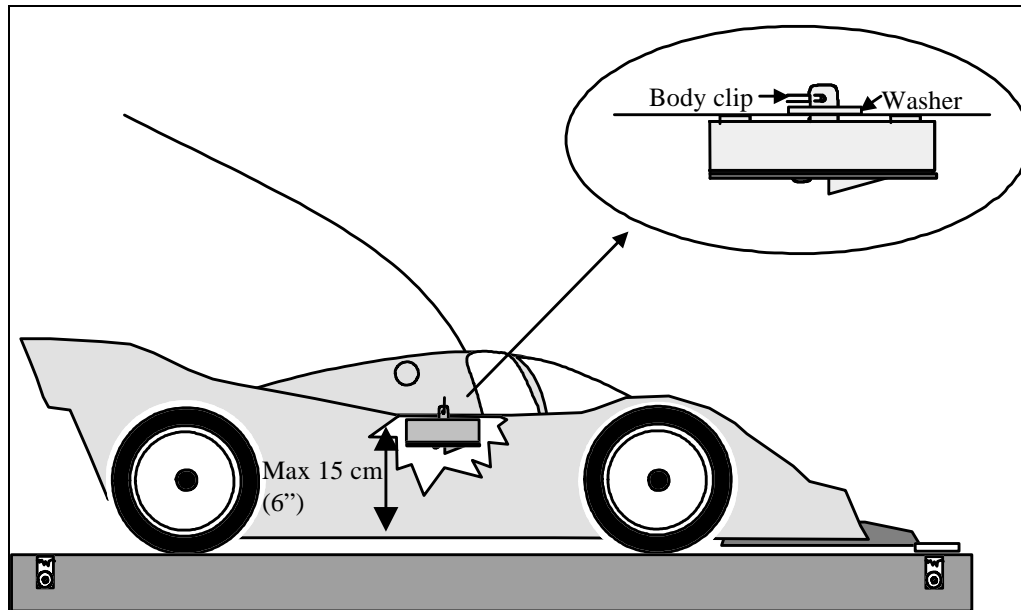

The transponder must be mounted **horizontally** at all times, preferably inside the RC model car against the side, with the fixing pin pointing upwards or downwards. The position of the transponder must be identical in all RC model cars competing in the race. Put a washer around the fixing pin and fix the transponder with a fixing clip. Transponders may not be positioned more than **15 cm / 6''** (away) from the detection loop, with no metal or carbon fiber between it. It is preferable to mount the transponder as close as possible to the detection loop. Make sure the transponder can not get detached during a race.

For OFF-ROAD RC model cars, the transponder may be fixed underneath the rear wing of the RC model car.

When the pin has been forcefully removed from the transponder, the transponder cover can be replaced (part number 00551102).



## 6. Charging the transponder

When charged, the AMBrc transponder constantly emits its magnetic output signal. Battery capacity is sufficient for 18 hours.

Charging must be done in the AMB charger rack, preferably at room temperature since Nimh cells do not charge well at temperatures below 14°C/57°F. When charging, the red LED in each transponder indicates it is charging. A green LED indicates that the transponder is fully charged.

The charging cycle for an empty transponder is as follows:

1. During the first five hours the transponder will be fast charged, indicated by a steady red LED on the transponder
2. After five hours of charging the charging cycle will be replaced with a slower charge, as indicated by a blinking red LED (LED blinks every second).
3. Full charge is reached after a total of 10 hours of charging and is indicated by a steady green LED. A full charge is sufficient for a minimum of 18 hours of operating time.
4. When the transponder is removed from the charger rack the LED will blink green (when sufficiently charged).
5. A low battery voltage is indicated by a blinking red LED (LED blinks every second).

The amount of time the transponder blinks red (when nearly empty) depends of the amount of charge the battery has received. When charged until full, the transponder may blink the red LED for half an hour or longer. If a transponder is re-charged from partly empty and the 5 hours fast charge have past, the transponder will always re-charge at the slower charge rate.

When transponders have not been used for a couple of months, the first re-charge will not be fully effective. To ensure maximum capacity, give the transponders a full charge and discharge cycle before use. Use the full charge/ discharge cycle to check if transponders have sufficient operating time.

Keep transponders at least 1 meter / 3 ft away from coax cables and the decoder, to avoid unwanted inputs.

**Warning:** Airline regulations demand all electronics to be switched-off when on board aircraft. The AMBrc transponders switch themselves off when the Nimh cells are empty. When airline travel is expected after a race event, do not charge longer than necessary to proceed with the races. The transponder switches on as soon as re-charging starts.

## 7. Operating the system / Trouble shooting

### Start-up

To enable compatibility with the widely used AMB20 software from various sources, the AMBrc decoder starts-up in AMB20 mode and uses the data format of the AMB20 decoder. As the AMB20 system uses only the transponder numbers 1 to 20, the AMBrc decoder in AMB20 mode sends only the **last digit** of the 7-digit transponder number. For example: AMBrc transponder number 1234567 shows as transponder number 7, but transponder number 6543217 shows up as transponder number 7 as well (not as 17). In order to have the full benefit of the 7-digit individual and unique transponder number suitable AMBrc software must be used, which makes the AMBrc decoder to switch over from AMB20 mode to AMBrc mode.

### Led indications

When switched-on the decoder shows a red LED and is in the initial AMB20 stop mode. The decoder must be started using proper (AMB20) software. When started, the LED shows green. Each time the decoder sends data, the LED flashes red.

### Noise level

Every 5 seconds the AMBrc decoder sends the average background noise (interference) level to the computer (not when in AMB20 mode). Noise becomes interference when it becomes noticeable (less reach of the transponders). The noise (strength) value has a range from 0 to over 200. Noise-level, as shown by the AMB software, should preferably not exceed 30. The received transponder signal-strength should be 60 or more above noise level to ensure perfect functioning of the system. Any electrical switch in the area or, usually at night, by short-wave radio stations can cause peaks in background noise level. Electronic equipment may also cause an increased background noise level. Switch-off the suspected equipment to find out. If you are using a bridge, please make sure the bridge is as short (less than 3m / 10 ft) and as low (less than 45 cm / 1.5 ft) as possible. In most cases, an increased noise level is the result of improper connections, insulation or wrong layout of the detection loop and/or coax cable. Also cables carrying interference from connected equipment installed too close to the detection loop are frequently the source of unwanted noise.

### Signal strength

Signal strength, as shown by AMBrc software, should preferably be not lower than 90 and at least 60 above the indicated background noise. Higher figures, for instance due to transponders closer to the track, give a higher immunity against interference. Transponders in a wrong position, which give strength of less than 50, will not be detected.

### Hits

The number of hits, as shown by AMBrc software, is an indication of the number of repeated contacts during a passing. The number of hits varies with the speed of a passing transponder. Transponders should not get closer than 2.5cm / 1" to avoid interfering on each other signals, resulting in low hits. Hits less than 10 indicate very high speeds or substandard performance. If low hits occur at low speeds, please check the loop installation and noise level.

### **Problems**

Most problems concerning the functioning of the system are due to bad connections or improper installation. Mobile phones and other forms of personal radio communications do not affect AMB i.t. systems.

If you still have questions or problems, please contact AMB i.t. by fax or e-mail supplying the following data:

1. Description of the problem and the purpose the system was used for.
2. Decoder and transponder type and their serial numbers.
3. Worst noise level and minimum indicated transponder signal strength.
4. Use of in-track or bridge detection loop.

**To contact AMB: please see address chapter 9.**

## 8. Technical Specifications

### AMBrC Decoder

Dimensions	: 120x170x55mm / 4.7"x6.7"x2.2"
Weight	: 0.8 kg / 1.9lb
Clock stability	: 25 PPM
Timebase Resolution	: 0.001s in AMBrC mode
Timing Resolution	: better than timebase of used AMB transponder type
Memory	: 5000 passings
Temperature range	: 0 - 50C / 32 - 122F
Humidity range	: 10% to 90% relative
Operating voltage range	: 10 to 16VDC (12VDC input)
Power consumption	: 0.1A via 12VDC input : 0.3A via USB
Output	: RS232, 9600 baud, 8 bit, 1 stop-bit, no parity
Number of loops	: 1 (or 2 with help of T splitter)
Max. track width	: max. 10m (33'), when 2 loops are used: 5 m / 16.5"
Aux. Inputs	: 3x opto coupled 4-12 VDC / 5-15 mA
Aux. Outputs	: 2x opto coupled, max 10mA
Compatible with the following AMB transponder types	: AMBrC (rechargeable type), AMBrC direct power
USB connection	: not implemented yet, but power can be applied.

### AMBrC Rechargeable Transponder

Dimensions	: 35x31x12 mm / approx. 1.4"x1.2"x 0.5"
Weight	: 22 g
Humidity	: max. 90% relative
Max. speed	: 120 km/h / 75 mph.
Temperature range	: 0-50 C / 32-122 F
Operating time	: min. 18 hrs
Charge indicator	: LED indicator green / red
Signal transfer	: magnetic induction
Resolution timebase	: 3 ms
Transponder position	: max. height 15 cm / 6"
Charging voltage	: 3.3 VDC

### Transponder Charger

Dimensions	: 380x117x65 mm / approx. 15"x5"x3"
Capacity	: 20 transponders
Power supply	: 10 to 16VDC / 0.4 A via 115/230 VAC adapter

### AMBrC Direct Powered Transponder

Dimensions	: 22x38x7 mm / approx. 0.9"x1.5"x 0.3"
Weight	: 10 g
Humidity	: max. 90% relative
Max. speed	: 120 km/h / 75 mph.
Temperature range	: 0-50 C / 32-122 F
Operating time	: Unlimited
Signal transfer	: magnetic induction
Resolution timebase	: 3 ms
Transponder position	: max. height 15 cm / 6"
Power	: Power feed from a free receiver channel (ch3 or batt)
Connection Plug	: Connect using a standard servo plug
Operating Time	: Active while external power applied
Power consumption	: Uses less than 10mA
Operating voltage	: 4 - 8 VDC

### Detection Loop

Track width	: max. 10 m / 33 ft (or 2x 5 m / 16.5 ft)
Coax to decoder	: max. 200 m / 660 ft

Specifications are subject to change without notice

## 9. FCC and CE regulations

The **FCC regulations** state that the following text must be put on a **prominent position** in the manual:

This equipment complies with part 15 of the FCC rules. Operation is subject to the following two conditions: (1) This equipment may not cause harmful interference, and (2) this equipment must accept any interference received, including interference that may cause undesired operation.

Note: This equipment has been tested and found to comply with the limits for a Class B digital device, pursuant to part 15 of the FCC rules. These limits are designed to provide reasonable protection against harmful interference in a residential installation. This equipment generates, uses and can radiate radio frequency energy and, if not installed and used in accordance with the instructions, may cause harmful interference to radio communications. However, there is no guarantee that interference will not occur in a particular installation. If this equipment does cause harmful interference to radio or television reception, which can be determined by turning the equipment off and on, the user is encouraged to try to correct the interference by one or more of the following measures:

- Reorient or relocate the receiving antenna.
- Increase the separation between the equipment and receiver.
- Connect the equipment into an outlet on a circuit different from that to which the receiver is connected

The required FCC ID's are indicated on the transponders and decoder.

**Caution:** Changes and modifications to the AMB system may change the levels of wanted and/or unwanted radiation and could void the users authority to operate the equipment. Before any modification is made, please contact AMB i.t.

The **EC regulations** require a declaration of conformity and declaration of product quality assurance (see enclosed)

The regulations stipulate also that the following text must be indicated as **Important Notice:**

When equipment fulfills the regulations valid in one of the EC countries, this equipment may be imported and traded in any other EC country. This is also the case for AMB equipment. Unfortunately the use of frequencies in is not (yet) harmonized, which means that the use of a given frequency that is allowed in one EC country is not automatically allowed in another EC country and vice versa. This results in the fact that, in some countries, you may buy (and sell) AMB equipment, but they may not be switched-on. The AMB transponders operate on magnetic induction only, therefore they have no antenna, but a built-in coil instead. The transponders do not produce an electromagnetic (radio) wave but only a magnetic wave. The difference between an electromagnetic (radio) wave and a magnetic wave is that the electromagnetic wave travels by itself over great distances and the magnetic wave does not. Therefore AMB transponders do not act as transmitters, have a very limited range and can therefore not interfere with any outside radio transmission.

The crossed out member states have restrictive use:

<del>AUS</del>	<del>B</del>	<del>DK</del>	<del>FIN</del>
<del>F</del>	<del>D</del>	<del>GR</del>	<del>IRE</del>
<del>I</del>	<del>LUX</del>	<del>NL</del>	<del>P</del>
<del>E</del>	<del>S</del>	<del>UK</del>	

### Manufacturer

AMB i.t. B.V.  
 Herenweg 29A  
 2105 MB Heemstede  
 The Netherlands  
 Tel: ++31 23 529 1893  
 Fax: ++31 23 529 0156  
 Homepage: [www.amb.nl](http://www.amb.nl)  
 E-mail: [support@amb.nl](mailto:support@amb.nl)

### US-Office

AMB i.t. US Inc.  
 1631 Phoenix Blvd., Suite 11  
 College Park, GA 30349  
 U.S.A.  
 Tel. 770-997-8882 / 877-426-2488  
 Fax. 770-997-0699  
 Homepage: [www.amb-us.com](http://www.amb-us.com)  
 E-mail: [support@amb-us.com](mailto:support@amb-us.com)



# Declaration of Conformity

We, the undersigned,

<b>Company</b>	AMB i.t. Holding B.V.
<b>Address, City</b>	Herenweg 29a, 2105 MB Heemstede
<b>Country</b>	The Netherlands
<b>Phone number</b>	+31 23 529 18 93
<b>Fax number</b>	+31 23 529 51 82

certify and declare under our sole responsibility that the following equipment:

<b>Product description / Intended use</b>	5.0 MHz low power inductive laptiming system
<b>EU /EFTA memberstates intended for use</b>	<b>EU:</b> Austria, Belgium, Denmark, Finland, France, Germany Greece, Ireland, Italy, Luxembourg, the Netherlands, Portugal, Spain, Sweden, United Kingdom <b>EFTA:</b> Switzerland, Iceland, Lichtenstein, Norway
<b>Restrictive use</b>	Those EU members where the 5.0MHz frequency is not allowed for this application
<b>Manufacturer</b>	AMB i.t. Holding B.V.
<b>Brand</b>	AMBrC
<b>Types</b>	AMB rc Decoder AMB rc Transponder AMBrC DP AMBrC F102RP-5

is tested to and conforms with the essential radio test suites included in following standards:

Standard	Issue date
EN 300 330	V.1.2.2. (May-1999)
ETS 300 683	June 1997
EN 60950	(1992), incl. A1(1993), A2(1993),A3(1995), A4(1997)

and therefore complies with the essential requirements and provisions of the **Directive 1999/5/EC** of the European Parliament and of the council of 9 march 1999 on Radio equipment and Telecommunications Terminal Equipment and the mutual recognition of their conformity and Annex IV (Conformity Assessment procedure referred to in article 10(4)).

The following Notified Bodies have been consulted in the Conformity Assessment procedure:

Notified Body number	Name and address
0122	NMi Certin B.V., POB 15, 9822 ZG Niekerk, The Netherlands

The technical documentation as required by the Conformity Assessment procedure is kept at the following address:

<b>Company</b>	AMB i.t. Holding B.V.
<b>Address, City</b>	Herenweg 29a, 2105 MB Heemstede
<b>Country</b>	The Netherlands
<b>Phone number</b>	+31 23 529 18 93
<b>Fax number</b>	+31 23 529 51 82



Drawn up in	Heemstede, The Netherlands
Date	June 21, 2000

	
Name and function	Harry van Dooren, General Manager



## Declaration of Product Quality Assurance.

In accordance with the Conformity Assessment procedure referred to in article 10(3) of **Directive 1999/5/EC of the European Parliament and of the Council of 9 march 1999** on Radio equipment and Telecommunication Terminal Equipment and their mutual recognition of their conformity (R&TTE directive) the following manufacturer:

<b>Company</b>	AMB i.t. Holding B.V.
<b>Address, City</b>	Herenweg 29a, 2105 MB Heemstede
<b>Country</b>	The Netherlands
<b>Phone number</b>	+31 23 529 18 93
<b>Fax number</b>	+31 23 529 51 82

declares under its sole responsibility that it has taken the following measures in order that the manufacturing process ensures compliance of the manufactured products with the technical documentation as established by Circuit Technology Woerden B.V. under requirements of the R&TTE Directive and with the requirements of the R&TTE directive that apply to them:

Number	Measures taken in order that the manufacturing process ensures compliance of the manufactured products
1	Manufacturing of the equipment is done under iso9001 certification number 652035 (See copy of ISO 9001 certification attached)
2	End product quality control is assessed on accordance with AMB i.t. Holding B.V. product quality control procedures, as described and contained in document entitled AMBRC System Quality Assurance, issue 21-06-2000, version 01
3	Full operational test according to customer specifications

Above mentioned measures are related to production of the following product:

<b>Brand</b>	AMBrc
<b>Type</b>	AMB rc Decoder AMB rc Transponder AMBrc_DP AMBrc_F102RP-5
<b>Product description / Supplementary info</b>	5.0 MHz low power inductive laptiming system



Drawn up in	Heemstede, The Netherlands
Date	June 21, 2000

	
Name and function	Harry van Dooren, General Manager