

# Contents

---

<b>INTRODUCTION</b> .....	3
<b>INSTALLATION OF THE DETECTION LOOP</b> .....	4
2.1 Positioning.....	4
2.2 Installation of the detection loop.....	6
2.3 Testing the detection loop installation.....	8
<b>INSTALLATION/OPERATION COMMUNICATOR</b>	10
3.1 Installation of the communicator.....	10
3.2 Charging instructions.....	12
3.3 Led indication.....	12
3.4 Sleep mode.....	13
3.5 Cleaning instructions.....	14

## Appendices

APPENDIX A - USEFUL TOOLS/PARTS/EQUIPMENT.....	15
APPENDIX B - TECHNICAL SPECIFICATIONS.....	16
APPENDIX C - CE AND FCC REGULATIONS.....	17
GUARANTEES & WARRANTIES.....	18

## Figures

Figure 1.1 System overview.....	3
Figure 2.1 Detection loop installation overview.....	4
Figure 2.2 Soldering the loop wire end.....	6
Figure 3.1 Communicator placement.....	10
Figure 3.2 Fastening the communicator in the holder.....	11
Figure 3.3 Charging cradle.....	12
Figure 3.4 Led indication.....	13

## **Contact Information**

### **AMB i.t. Europe**

Amsterdam  
The Netherlands  
Tel: +31 23 529 1893  
E-mail:  
support@amb-europe.com

### **AMB i.t. America**

Atlanta  
USA  
Tel: +1 678 816 4000  
E-mail:  
support@amb-us.com

### **AMB i.t. Asia (Japan Branch)**

Tokyo  
Japan  
Tel: +81 3 5275 4600  
Email:  
support@amb-japan.com

### **AMB i.t. Asia (Australian Branch)**

Sydney  
Australia  
Tel: +61 2 9546 2606  
Email:  
support@amb-australia.com

**www.amb-it.com**



**All rights reserved**

Copyright © 2009 AMB i.t. BV

This publication has been written with great care. However, the manufacturer cannot be held responsible, either for any errors occurring in this publication or for their consequences.

The sale of products, services or goods governed under this publication are covered by AMB i.t.'s standard Terms and Conditions of Sales and this product Manual is provided solely for informational purposes. This publication is to be used for the standard model of the product of the type given on the cover page.

AMB i.t.

Manual: Communicator Lite/Rev.01-09

# 1: Introduction

The TnetX Pro system is designed to count laps for cars and motorcycles. The signal sent by a Communicator Lite (communicator) is picked up by the detection loop installed in the track surface. The communicator is mounted on a car or motorcycle. The detection loop is connected to the TnetX Pro Host (host). The host timestamps the received communicator signals and sends this data to a connected computer.

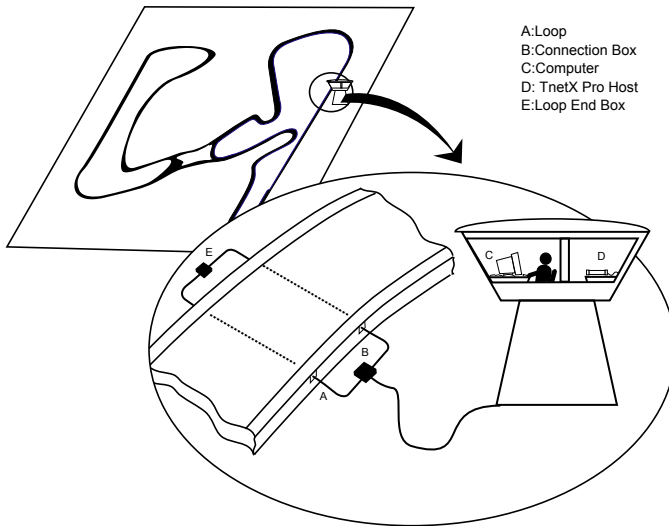

**Figure 1.1 System overview**

## 2: Installation of the detection loop

To install the TnetX Pro system, one needs to install one or more detection loops, connect the host and mount the communicator to the car/motorcycle. For optimal results, please follow the instructions as described carefully. Appendix B contains a list of useful tools for installing the detection loop.

### 2.1 Positioning

All wiring of the detection loop must be installed according to the drawing below in order to avoid a serious degradation in the performance of the system.

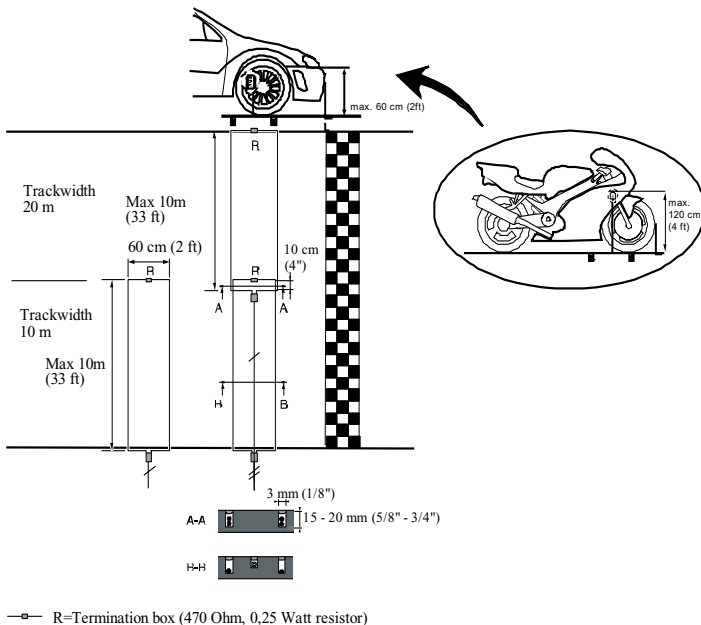

**Figure 2.1** Detection loop installation overview

- a) The detection loop must be positioned in such a way that the communicator is above the center of the detection loop when the front of the cars/motorcycle crosses the finish line. Make sure cars/motorcycle cannot pass outside the detection loop. Extend the detection loop outside the track if necessary.
- b) One loop can be used for a track width of max. 10m (33ft). For wider tracks use 2 or 3 (max.) loops. When 2 or 3 detection loops need to be installed, make them of even length with 10 cm (4") overlap.
- c) With a separate loop in the pitlane, connected to the BNC connector marked, loop 3 (PIT) on the host, passings registered in the pit lane can be identified as such by the host.
- d) The detection loop is sensitive to interference, sometimes emitted by nearby cables. When possible, keep other cables 5 m (15 ft) away. Also, make sure cars/motorcycles or other parts on the track will not get closer than 5 m (15 ft) to the detection loop, to avoid false inputs.
- e) For dirt tracks, the detection loop is best installed in plastic conduits at a maximum of 30cm (1ft) below the surface. The maximum depth should be chosen in a way that the cars/motorcycles cannot dig out the detection loop. However please respect the maximum distance between loop and communicator, which is 60cm (2ft) for cars and 120cm (4ft) for motorcycles.

---

### **LEARNED BY EXPERIENCE**

When pulling the detection loop wire through the plastic conduit, it is a good idea to pull another non-metal wire through. This wire then can be used to install a new loop wire in case it gets damaged.

---

## 2.2 Installation of the detection loop

- a) Cut the slots in the track a maximum of 2 cm (3/4 in) deep and 60 cm (2 ft) apart. Make sure the slots are clean and dry. This will ensure a perfect seal when the silicon is applied after the installation of the wiring.  
Put the wires of the detection loop in the slots and cut the excess length of the detection loop wires.
- b) Widen the slot with a chisel where the small connection box of the loop is to be installed. Place the connection box vertically.
- c) When all wires are installed, put the heat shrinkage sleeve over a detection loop wire end. Then solder the loop wire to the short wire end of the connection box. When soldering the wires together, the solder should flow through the entire connection and not only around it. Now put the shrinkage sleeve over the soldered connection and hold it over a heat source to shrink the sleeve (also see the drawing below). Repeat this procedure for the second wire of the detection loop.

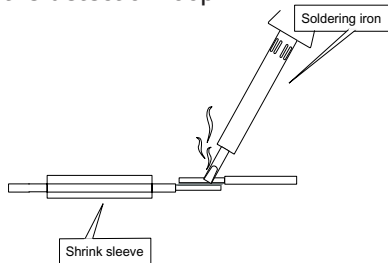

**Figure 2.2 Solder the loop wire end**

- d) Fill the slot with silicone. Before doing this, please test the loop as described in section 2.3. Make sure not to overfill the slots and that the silicone is fully under the surface of the track, otherwise tires may pull out the silicone.

If any silicone spills out of the slot, remove the excess silicone by scraping the top with a small piece of cardboard. This also ensures that the silicone is pressed into the slot for a perfect seal.

---

### **LEARNED BY EXPERIENCE**

If you wish, you may pad the slots with backing rod or nylon cord before sealing the slot with silicone. This helps to prevent the excessive use of silicone and is also useful when pulling out the silicone if the detection loop has to be replaced.

### **Silicone**

There is a wide variety of silicone types available in hardware stores; it is important that the right type is used. Silicone that can withstand different temperatures as well as both wet and dry conditions (since weather situations can vary ), should be used. If you are unsure, check the specifications of the silicone.

The following types of silicone have been shown to yield lasting results and are recommended by AMB:

- Dow Corning 890SL is a self-leveling silicone kit. It is applied as a liquid and fills the slot completely.
  - Purflex is a polyurethane-based silicone that retains its elasticity under a wide range of temperatures.
-

## 2.3 Testing the detection loop installation

Once the loop has been installed, it should be tested to ensure that it is functioning correctly. We also recommend repeating the same procedure at the start of each race event. You can determine if your loop is functioning correctly by doing the following tests:

- a) Connect the detection loop to the host and computer running AMB i.t. timing software (also see the separate TnetX Pro Host manual).  
Check the background noise, which is updated every five seconds in the AMB i.t. timing software. The background noise level should be between 0 and 40 points. A higher value may indicate interference by other electrical equipment in the area or a bad loop installation.  
Try switching off any suspected equipment or removing nearby objects and check for improvements. Especially at night, short-wave radio transmitters may cause an increased background noise.
- b) If a detection loop has been correctly installed, a communicator should be picked up at the same distance along the entire detection loop. To test this, stand at one end of the detection loop about 8 m (25 ft) away and hold a communicator approximately 120 cm (4 ft) off the ground. Walk slowly towards the detection loop. The 'loop' sign at the display will filled in when the communicator is detected. Mark the spot where the communicator was detected. Repeat the process for the middle and other end of the detection loop and do the same coming from the other direction. The detection distance from the loop should be approximately the same for all positions (< 20% variation).



- c) Check the signal strengths of the communicators as they are picked up by the system during a test with motorcycles (also see paragraph 3.1 Installation of the communicator). A good loop will yield consistent communicator signal strengths of at least 100 points with a hit rate of at least 10 points. The hit rate may vary depending on the speed of the communicator passings (slower passings yield higher hit counts), but the signal strength should be consistent (< 10 points variation).

# 3.Communicator Installation/ Operation

## 3.1 Installation of the communicator

The communicator can be recharged in a single charger or 34-position charger case.

### Positioning the communicator

The position of the communicator must be identical on all cars or motorcycles competing in the race. Fix the communicator vertically, max. 60cm (2ft) above the track for cars and 120cm (4ft) for motorcycles. Make sure that the communicator has a clear view to the track with no metal or carbon fiber beneath it. Maximum operating temperature should not exceed 122F/50°C.

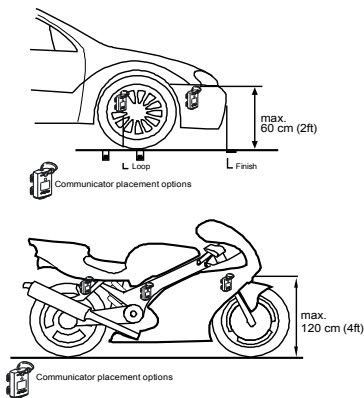

Please note that: The front wheel well is the preferred position.

**Figure 3.1 Communicator placement**

## Installation of the communicator

Fix the holder on the car/motorcycle with the fixing rod on top by using tie-wraps or screws. Fasten the communicator in the holder using the supplied fixing pin.

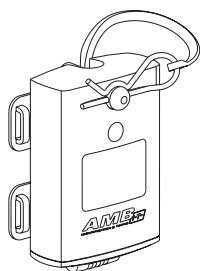
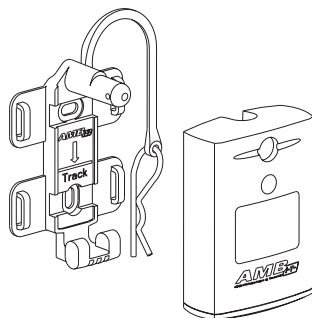

**Figure 3.2 Fastening the communicator in the holder**

## WARNING

A detached communicator can be very dangerous!  
Make sure the communicator cannot get detached.  
Use additional tie-wraps to secure the pin.

### 3.2 Charging instructions

Communicators can be charged in an individual charger or in a charger case.

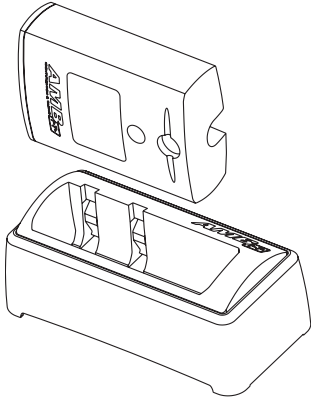

**Figure 3.3 : Charging cradle**

- Plug the power adapter into an electrical outlet and place the communicator on the charging unit.
- The communicator's Led will flash red indicating that the communicator is charging.
- After about 16 hours a steady green Led indicates that the communicator is fully charged.

A full charge yields a minimum of 5 days use. The Led flashing color and pattern indicates the remaining working days of the communicator. See the next paragraph for the complete information.

### 3.3 Led indication

The Led on the communicator provides the information of the communicator status

LED Flashing color/pattern	Description
Flashing ...times green	Minimum ... days left before the battery is empty
Flashing red (not in the charger)	Less than 1 day of functioning left
Continuously red	The communicator stops working at any moment, charging is required
No Light	Communicator is discharged
Flashing red (in the charger)	Communicator is charging
Continuous green (in the charger)	Communicator fully charged
No Light (in unplugged charger)	Communicator is in sleep mode

**Figure 3.4: Led indication**

### 3.4 Sleep mode

The sleep mode is designed to turn off the communicator's signal and save battery life. It is necessary to use the Sleep mode when travelling by airplane to adhere to airline regulations. While in Sleep mode, the communicator's charge-discharge cycle will last up to 3 times longer.

Switching a communicator into sleep mode

A charged/functioning communicator can be put into a sleep mode by placing it in an unpowered charging cradle or charger case.

Switching the communicator back to normal mode

Normal functioning resumes when the communicator is removed from the cradle or charger case.

### **3.5 Cleaning instructions**

Over the course of time, communicator can become soiled in various ways. Normal dirt can be removed from the communicator with a soft brush and warm clean water up to 50°C. Cleaning electrical contacts: We recommend to spray Isopropyl alcohol on the contacts of the communicator and on the charger. Rub the contacts with ear sticks to clean them on a regular basis.

#### **Caution**

MAKE SURE THE COMMUNICATOR IS DRY BEFORE CHARGING.

CHARGE YOUR COMMUNICATOR ONCE EVERY 3 MONTHS.

DO NOT LEAVE THE COMMUNICATOR IN A POWERED CHARGING CRADLE OR CHARGING RACK MORE THAN 24 HOURS.

DO NOT CLEAN COMMUNICATOR WITH AUTOMOTIVE CLEANING PRODUCTS OR OTHER DETERGENTS.

DO NOT USE HIGH PRESSURE WATERGUNS OR OTHER (DISH)WASHING MACHINES TO CLEAN OR RINSE THE COMMUNICATOR.

## **Appendix A: Usefool tools/parts/ equipment**

---

### Useful Tools

- Multi meter (Range at least: 1 Ohm - 1 Mega Ohm)
- Wire cutter / stripper
- BNC Crimp tool for RG 58 & RG 59
- (Butane) Soldering gun
- Blade knife
- Coax stripper
- Screw driver (normal and Phillips)

### Useful Spare Parts

- BNC couplers (3 pieces)
- BNC connectors (5 pieces) for yellow coax
- BNC connectors (5 pieces) for brown coax
- Shrink sleeves
- Spare loop (for tracks up to 20 m (65 ft) wide)
- Electrical tape

### Additional Tool for new loop installations

- Chalk line to get a straight line on the track surface
- Caulk gun to apply silicone.

Please contact AMB i.t. if you would like to receive detailed specifications on any of the above items. You can find our contact details on page 2 of this manual.

## **Appendix B: Technical Specifications**

### **Communicator Lite**

Numbers available	: unlimited
Dimensions	: 73x50x22 mm (approx. 2.9x2x0.9")
Weight	: 100 g
Housing	: Water- and shockproof
Max. speed	: 260 km/h (160 mph)
Timing Resolution	: 0,1 sec
Temperature range	: 0 - 50 °C (32 - 122 °F)
Operating time	: min. 5 days after full charge
Charge time	: min. 16 hours for full charge
Charge indicator	: LED indicates remaining operating time in days
Signal transfer	: magnetic induction
Communicator position	: max. height cars 60 cm (2ft), max. height motorcycles 120 cm (4ft)

### **AMB Detection Loop**

Track width	: max. 20 m (65 ft)
Coax to TnetX Pro Host	: max. 100 m (330 ft)

### **AMB Communicator Chargers**

Individual charger	: 12 VDC / 0.05 A
34 position charger case	: 12 VDC / 1.0 A

Specifications are subject to change without notice.



## **Appendix C: CE and FCC Regulations**



### **CE information:**

This device complies with the EMC directive 89/336/EEC. A copy of the declaration of conformity can be obtained at:

AMB i.t. BV  
Zuiderhoutlaan 4  
2012 PJ Haarlem  
The Netherlands



### **FCC information:**

This equipment complies with part 15 of the FCC rules. Operation is subject to the following two conditions: (1) This equipment may not cause harmful interference, and (2) this equipment must accept any interference received, including interference that may cause undesired operation.

---

## **Guaranties & Warranties**

---

AMB i.t. guarantees that, for a period of twenty four months from the date of dispatch, hosts manufactured or sold by AMB i.t. with defects caused by faulty materials and/or workmanship and/or design, will be repaired. If repair is not possible or economical for AMB i.t., AMB i.t. has the choice to refund the purchase price of these goods or to deliver new goods. AMB i.t.'s liability shall be strictly limited to replacing, repairing or issuing credits at its option for any goods returned within twenty four months from the date of dispatch. AMB i.t. shall not be liable for incidental or consequential damages including, but not limited to costs of removal and reinstallation of goods, loss of goodwill, loss of profits or use. If the requirements set forth above and described below are not complied with, the AMB i.t. warranty/guarantee shall not apply and AMB i.t. shall be discharged from all liability arising from the supply of defective goods.

EXCEPT AS EXPRESSLY PROVIDED IN THIS SECTION, AMB i.t. MAKES NO REPRESENTATIONS OR WARRANTIES OF ANY KIND, NATURE OR DESCRIPTION, EXPRESS OR IMPLIED, INCLUDING WITHOUT LIMITATION, ANY WARRANTY OR MERCHANTABILITY, FITNESS OF THE GOODS FOR ANY PARTICULAR PURPOSE, OR NONINFRINGEMENT, AND AMB i.t. HEREBY DISCLAIMS THE SAME.

Please see the AMB standard Terms and Conditions of Sale for the additional terms in connection with the sale of goods and services covered by this manual.

### **Remedies and damages**

AMB i.t. shall not incur any liability under the above warranty unless:

- a) AMB i.t. is promptly notified in writing upon discovery by the customer that such goods do not conform to the warranty and the appropriate invoice number and date of purchase information is supplied;
- b) The alleged defective goods are returned to AMB i.t. carriage pre-paid;
- c) Examination by AMB i.t. of goods shall confirm the alleged defect exists and has not been caused by misuse, neglect, method of storage, faulty installation, handling, or by alteration or accident.