

CONTACT INFORMATION	2
1. DECODER INSTALLATION/OPERATION	3
1.1 Installation of the decoder.....	3
1.2 Operating the MYLAPS X2 Prochip decoder.....	4
1.2.1 Noise level	4
1.2.2 Signal Strength.....	4
1.3 Menu options explained.....	5
1.3.1 MENU: Network	6
1.3.2 MENU: Switch Firmware.....	7
1.3.3 MENU: Factory defaults.....	7
APPENDIX A - FAQs	8
APPENDIX B - CE AND FCC REGULATIONS	10
APPENDIX C - TECHNICAL SPECIFICATIONS	11
GUARANTEES & WARRANTIES.....	12

MYLAPS EMEA Office

Haarlem
The Netherlands
Tel: +31 23 7600 100
E-mail: info@mylaps.com

MYLAPS Americas Office

Atlanta
USA
Tel: +1 678 816 4000
E-mail: info.americas@mylaps.com

MYLAPS Japan Office

Tokyo
Japan
Tel: +81 3 5275 4600
Email: info.japan@mylaps.com

MYLAPS Asia Pacific Office

Sydney
Australia
Tel: +61 2 9546 2606
Email: info.asia.pacific@mylaps.com

MYLAPS Asia Office

Kuala Lumpur
Malaysia
Tel: +60 356 131 235
Email: info.asia@mylaps.com

www.mylaps.com

All rights reserved

Copyright © 2011-2015 MYLAPS

This publication has been written with great care. However, the manufacturer cannot be held responsible, either for any errors occurring in this publication or for their consequences.

The sale of products, services of goods governed under this publication are covered by MYLAPS's standard Terms and Conditions of Sales and this product manual is provided solely for informational purposes. This publication is to be used for the standard model of the product of the type given on the cover page.

1: Decoder Installation/Operation

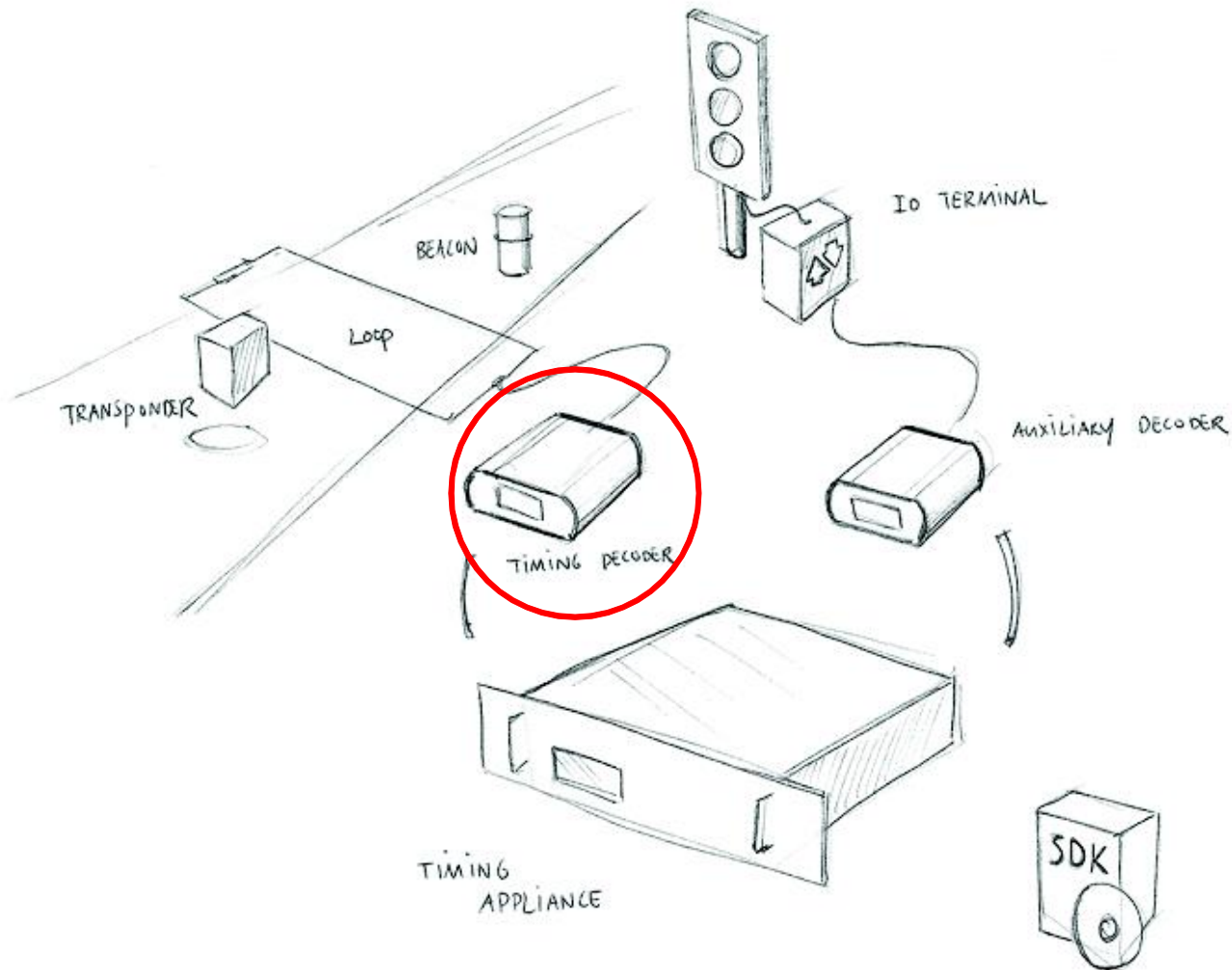

Figure 1.1 System overview

1.1 Installation of the decoder

The MYLAPS X2 Prochip decoder is a precision instrument. Therefore please handle it with care and keep the MYLAPS X2 Prochip decoder out of direct sunlight and avoid high humidity. Take special precautions in case of thunderstorms by disconnecting all cables (coax, Ethernet and mains) from the MYLAPS X2 Prochip decoder. Nearby lightning strikes can damage the decoder when these cables are connected.

Setting up and operating the MYLAPS X2 Prochip decoder may only be done by certified professionals.

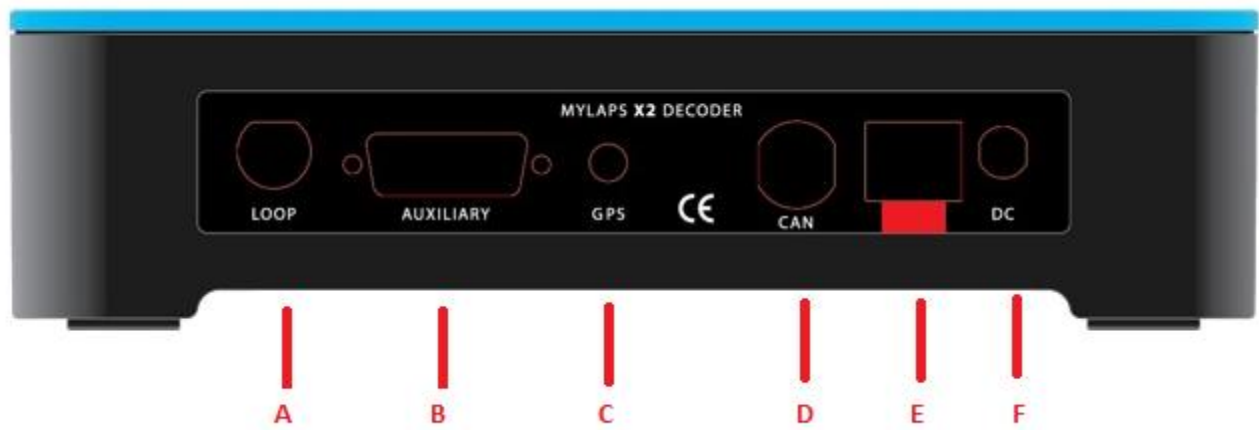

Figure 1.2 Connections of the decoder

How to connect

A	The detection loop: Connect the supplied 75 Ohm double-shielded coax cable to the MYLAPS X2 Prochip decoder.
B	The auxiliary port: This port can be used to connect a photocell, external start pulse or a sync pulse. For more information on how to connect these devices, see appendix D.
C	The GPS antenna: Connect the GPS antenna cable and place the antenna where it has a clear view of the sky overhead to be able to make connections to satellites
D	CAN connector: for future use
E	The network: This port can be used to connect the network cable between the decoder and the network connection port of the computer.
F	Power: Connect the supplied VDC adapter to the decoder and mains. It is recommended to connect the VDC adapter to mains through an Uninterruptable Power Supply (UPS) to avoid any interruption of power supply to the decoder.

1.2 Operating the MYLAPS X2 Prochip decoder

The decoder is not equipped with an on/off switch therefore connecting the decoder to the mains will switch it on. This will enable timing of transponder passings after approximately 15 seconds. With each detection of a transponder the received transponder information is shown on the decoder display.

1.2.1 Noise level

The decoder determines the average background noise. Noise level should not exceed -85 dBm. If the noise level is higher, the received transponder signal strength should be at least 20 dBm above noise level to ensure proper functioning of the system. So if the transponder received signal strength is -55 dBm, the noise should not exceed -75 dBm.

1.2.2 Signal strength

Transponder signal strength should preferably be above -65 dBm and should at least be 20 dBm higher than the indicated background noise. The closer the transponder is to the track, the higher the received signal strength will be. A higher transponder signal strength should allow for greater immunity against outside interference.

1.3 Menu options explained

On the front of the decoder, you will find an information display designed to view and change the decoder settings. The status screen will show the following information:

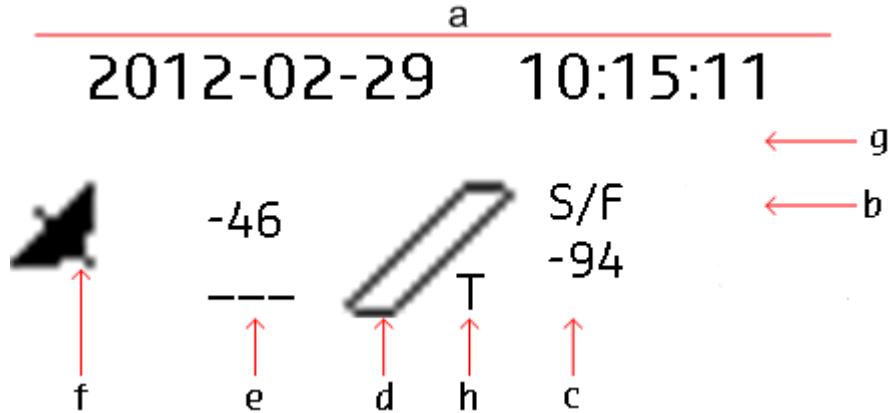





A	Decoder date/time, UTC when synchronized to GPS or NTP
B	Timeline name
C	Background noise indication in dBm
D	Indication that hits are received, remains black when a transponder is being received by the loop
E	Strength of last received transponder in dBm
F	Blinks when GPS receiver attached, steady when decoder is locked to UTC time
G	Message line
H	Not available on X2 Prochip decoder

You can navigate between the menu items with the Select button and you can choose an option with the Acknowledge button. Please note that you can go one step back by selecting << and clicking the Acknowledge button.



By clicking on the acknowledge button you will cycle through the following status screens:

	Active IP address
	MAC address/serial number
	Firmware version
	GPS status
	Remote connections

By clicking on the Select and Acknowledge buttons you can choose which information you want to see on the display. Detailed information of the menu options will be given on the following pages. The "Select" button will highlight the next option on the menu when pressed. The "Acknowledge" button will either open the highlighted sub-menu or select the highlighted option, depending on the situation.

By clicking on the select button you will find a main menu with different subjects:

Network	DHCP
	IP address
	Network mask
	Gateway
	DNS server
Switch Firmware	
Factory Defaults	

1.3.1 MENU: Network

Within the Network menu you can choose/see:

DHCP:

You can select here either On or Off. If your decoder is placed in a network the decoder will try via the DHCP server (DHCP = Dynamic Host Configuration Protocol) to get an IP address which is in the range of the network. Please note that it can take about 60 sec. to obtain the settings via DHCP.

IP address:

IP address of your decoder. An identifier for a computer or device on a TCP/IP network.

Subnet mask:

A mask used to determine what subnet an IP address belongs to.

Gateway:

A node on a network that serves as an entrance to another network.

DNS server:

Short for Domain Name System (or Service or Server), an Internet service that translates domain names into IP addresses.

1.3.2 MENU: Switch Firmware

Within the Switch Firmware menu you can switch the firmware. Firmware is software running inside the decoder - When you update the firmware in your decoder, the decoder will retain the current version of the firmware. With the switch firmware option you are able to revert back to the previous version.

1.3.3 MENU: Factory defaults

Within the Factory defaults menu you can reset to the factory defaults. This means that you can reset the settings of the decoder to the initial settings.

A1: Transponder is not being detected

A few transponders are not being detected.

If this is the case, the problem is most likely related to the individual transponder or the positioning of the transponder.

- Check the mounting position of the transponder, for more information check your transponder manual.

None of the transponders are being detected.

If this is the case, the problem is most likely related to the detection loop, decoder, timing computer or cabling. Please take the following steps:

- Check if the loop in the display changes to black during a transponder passing. If this is working, but nothing appears on the computer screen, check the cabling between the decoder and the computer.
- Check the coaxial cable by measuring the resistance (with multimeter) between the center pin and the outside of the BNC connector. The reading should be approximately 150 kOhm after 30 seconds. If not, the coaxial must be replaced.
- Check the loop wire by cutting the loop wires from the connection box and measuring the resistance between the loop wires in the track. The reading should be approximately 220 Ohm. If this is not the case, the loop must be replaced. When (re)connecting the loopwires to the connection box please solder with proper connections (for more information please check your system installation manual).

Error messages

- Activator overload: This means that the overcurrent protection of the activation circuit is working. A possible cause is a short circuit in the coaxial cable, or the use of an incorrect loop or connection box.
- Activator hot: This means that the temperature of the activator circuit is too high. The decoder must be used at ambient temperatures below 50C/122F, otherwise problems with the loop may occur.

A2: Noise level

What if my background noise is higher than -50 dBm?

An increased background noise is an indication of a higher interference level picked up by the system. The noise level should be as low as possible, but as long as the received signal from the transponders is at least 20 dBm higher than the noise level detection will be reliable. If the noise level is higher than -70 dBm, there is most likely something wrong with the installation.

Possible causes of high background noise levels:

- When the detection loop is damaged, a fluctuation in noise level will be noticeable, especially in wet conditions. If this is the case, please check the loop wire and coaxial for cuts or breakage.
- Electrical equipment too close (<3 m) to the loop or coaxial cable.
- Using a generator with a poor ground connection
- Use of DC/AC converter for AC power.
- Poor connections between the detection loop and the coaxial cable.
- BNC connector incorrectly fitted to the coaxial cable
- Poor ground connection of the AC power.

A3: Signal strength

What if the received signal strength is below -65 dBm?

- If the signal strength is lower than -65 dBm, please check the position of the transponder.
- If the signal strength is fluctuating heavily in combination with high noise levels, check the quality of the loop installation and coaxial cables.

CE information:

This device complies with the EMC directive 89/336/EEC. A copy of the declaration of conformity can be obtained at:

MYLAPS Sports Timing
Zuiderhoutlaan 4
2012 PJ Haarlem
The Netherlands

**FCC information:**

This equipment complies with part 15 of the FCC rules. Operation is subject to the following two conditions: (1) This equipment may not cause harmful interference, and (2) this equipment must accept any interference received, including interference that may cause undesired operation.

Warning (part 15.21)

Changes or modifications not expressly approved by the party responsible for compliance could void the user's authority to operate the equipment.

Information to the User (Part 15.105 (b))

Note: This equipment has been tested and found to comply with the limits for a Class B digital device, pursuant to part 15 of the FCC Rules. These limits are designed to provide reasonable protection against harmful interference in a residential installation. This equipment generates, uses and can radiate radio frequency energy and, if not installed and used in accordance with the instructions, may cause harmful interference to radio communications. However, there is no guarantee that interference will not occur in a particular installation. If this equipment does cause harmful interference to radio or television reception, which can be determined by turning the equipment off and on, the user is encouraged to try to correct the interference by one or more of the following measures:

- Reorient or relocate the receiving antenna.
- Increase the separation between the equipment and receiver.
- Connect the equipment into an outlet on a circuit different from that to which the receiver is connected.
- Consult the dealer or an experienced radio/TV technician for help.

Appendix C: Technical Specifications

Dimensions	220x180x60mm / 8,7x7x2,4inch
Weight	1500g / 3.3lb
Clock Stability	0,5PPM
GPS Receiver	quick fix, -160dB, 15nS
GPS antenna connection	SMA, active
Decoding circuitry up to	-100dBm sensitivity
Timing Resolution	0,001s
Loop connection	1x BNC, max. 16m loop
Operating temperature range	-20 to 50 C / -4 to 122F
Humidity range	10% to 90% relative
Operating voltage range	10 to 14.4V, Typical 12V
Power consumption	Type: 6W, Max.: 7.5W
Network Interface	10-100BT (RJ45)
Auxiliary connections	1x 5VDC, 100mA, output 1x Opto coupled closing contact, max 50mA, output 3x Opto coupled, 5-12VDC / 5-15mA, inputs
Auxiliary connector	DB15, Female
Can connection	Future use

Digital outputs:

Number of connections	1
Opt1	DB15 pin 14(+) and pin 4(-)
Isolation	Opto coupled photo-transistor
Signal type	Closing contact
Max. switched current	50mA (DC)
Max. switched voltage	70V (DC)

Digital inputs:

Number of connections	3
PhotoCell	DB15 pin 7(+) and pin 6(-)
ExtSt	DB15 pin 13(+) and pin 12(-)
Sync	DB15 pin 11(+) and pin 10(-)
Isolation	Opto coupled photo-transistor
Timestamp accuracy	0.0001 second
Required drive current (high)	10mA
Switch voltage range	5-12VDC

Power output:

Voltage	5VDC
Max current	100mA
5V	DB15 pin 8, 15
Gnd	DB15 pin 1, 5, 9

Specifications are subject to change without notice.

Guarantees & Warranties

MYLAPS warrants that, for a period of three (3) years from the date of shipping the decoders and the MYLAPS MX Rechargeable Power, MYLAPS RC DP, MYLAPS KART DP, MYLAPS Kart Rechargeable Power, MYLAPS Car/Bike DP, MYLAPS Car/Bike Rechargeable Power, MYLAPS Car/Bike Pro transponders, MYLAPS X2 transponder covered by this warranty with defects, as determined solely by MYLAPS, caused by faulty materials, workmanship or design will be repaired or replaced, unless such defects were the result of any of the following: shipping; improper installation, maintenance or use; abnormal conditions of operation; attempted modification or repair by the customer or any third party; use of the goods in combination with other items; or an act of God. If repair or replacement of the goods is not possible or economical for MYLAPS, MYLAPS may, at its option, refund the purchase price of the goods or deliver replacement goods at its sole discretion. MYLAPS's liability shall be strictly limited to replacing, repairing or issuing credits at its option.

MYLAPS warrants that, for a period of two (2) years from the date of shipping the ProChip, MYLAPS Kart Fixed Power and the MYLAPS RC Rechargeable Power transponders covered by this warranty with defects, as determined solely by MYLAPS, caused by faulty materials, workmanship or design will be repaired or replaced, unless such defects were the result of any of the following: shipping; improper installation, maintenance or use; abnormal conditions of operation; attempted modification or repair by the customer or any third party; use of the goods in combination with other items; or an act of God. If repair or replacement of the goods is not possible or economical for MYLAPS, MYLAPS may, at its option, refund the purchase price of the goods or deliver replacement goods at its sole discretion. MYLAPS's liability shall be strictly limited to replacing, repairing or issuing credits at its option.

MYLAPS warrants that, for a period of one (1) year from the date of shipping the MYLAPS Onboard Display kit covered by this warranty with defects, as determined solely by MYLAPS, caused by faulty materials, workmanship or design will be repaired or replaced, unless such defects were the result of any of the following: shipping; improper installation, maintenance or use; abnormal conditions of operation; attempted modification or repair by the customer or any third party; use of the goods in combination with other items; or an act of God. If repair or replacement of the goods is not possible or economical for MYLAPS, MYLAPS may, at its option, refund the purchase price of the goods or deliver replacement goods at its sole discretion. MYLAPS's liability shall be strictly limited to replacing, repairing or issuing credits at its option.

MYLAPS warrants that, for a period of one (1) year from the date of shipping, all other goods covered by this warranty with defects, as determined solely by MYLAPS, caused by faulty materials, workmanship or design will be repaired or replaced, unless such defects were the result of any of the following: shipping; improper installation, maintenance or use; abnormal conditions of operation; attempted modification or repair by the customer or any third party; use of the goods in combination with other items; or an act of God. If repair or replacement of the goods is not possible or economical for MYLAPS, MYLAPS may, at its option, refund the purchase price of the goods or deliver replacement goods at its sole discretion. MYLAPS's liability shall be strictly limited to replacing, repairing or issuing credits at its option.

If the requirements set forth above and described under Remedies and Damages are not complied with, our warranty/guarantee shall not apply and we shall be discharged from all liability arising from the supply of defective goods.

EXCEPT AS EXPRESSLY PROVIDED IN THIS SECTION, MYLAPS MAKES NO REPRESENTATIONS OR WARRANTIES OF ANY KIND, NATURE OR DESCRIPTION, EXPRESS OR IMPLIED, INCLUDING WITHOUT LIMITATION, ANY WARRANTY OR MERCHANTABILITY, FITNESS OF THE GOODS FOR ANY PARTICULAR PURPOSE, OR NONINFRINGEMENT, AND MYLAPS HEREBY DISCLAIMS THE SAME.

Remedies and Damages

1. MYLAPS shall not incur any liability under the above warranty unless:

- i) MYLAPS is promptly notified in writing upon discovery by the customer that such goods do not conform to the warranty, and the appropriate invoice number and date of purchase information is supplied;
- ii) The alleged defective goods are returned to MYLAPS carriage pre-paid;
- iii) Examination by MYLAPS of goods shall confirm that the alleged defect exists and has not been caused by unauthorized use (including, without limitation, the use of an AMB decoder with non-MYLAPS hardware) misuse, neglect, method of storage, faulty installation, handling, or by alteration or accident; and
- iv) With respect to MYLAPS decoders, customer has upgraded the firmware in its decoder within one month after MYLAPS has offered to provide customer with such upgraded firmware.

2. The customer acknowledges that the goods may include certain firmware imbedded therein. MYLAPS hereby grants a license to customer to use the imbedded firmware in an MYLAPS decoder, but only to the extent the decoder is used in connection with MYLAPS hardware. MYLAPS shall have the right to terminate the license immediately upon written notice to customer in case MYLAPS has a reasonable belief that customer at any time has used the MYLAPS decoder in connection with non-AMB hardware. Further, customer may not copy, compile, reverse compile, disassemble, translate, analyze, reverse engineer or attempt to reverse engineer the firmware, except as permitted by applicable law.

3. In addition, customer grants MYLAPS the option to repurchase any MYLAPS decoder if MYLAPS has a reasonable belief that customer has used the MYLAPS decoder in connection with non-MYLAPS hardware. The repurchase price shall be the fair market value on the date MYLAPS provides notice to customer that it intends to repurchase the decoder.

The above mentioned warranty/guarantee is irrespective of any rights granted to the buyer of MYLAPS equipment manufactured or sold by MYLAPS based on the laws of the Netherlands. Any correspondence regarding the above mentioned guarantee must be addressed to MYLAPS:

MYLAPS EMEA OFFICE HAARLEM

Zuiderhoutlaan 4 / 2012 PJ Haarlem / The Netherlands / info@mylaps.com / Fax +31 23 529 0156