

MULTI-CHANNEL FM WIRELESS INTERCOM

INSTRUCTION MANUAL

MODEL:HY777/HY787



Hosmart was founded in 2012 by a former group of Motorola engineers and designers. Now fast forward a few years and we are now the industries leader in home intercom and security products. Our vision is to become the world leader in home intercom products and solutions. We design as well as engineer intelligent home intercom systems. We want to be your homes solution. Our company philosophy is to focus our efforts and energy based on our client's wishes.

We are confident that you will enjoy and be satisfied with our products. Any damage or malfunction of Hosmart product is 100% guaranteed to be replaced.

For any question, you may contact us by:

<https://www.facebook.com/Hosmart-121987695152303/>

Phone: (320)-402-6574 ;
(334)-339-9357

E-mail: service@hosmartmall.com
or Website: www.hosmartmall.com
or scan the QR code.



FCC STATEMENT

FCC ID:2AJEM-HY777
POWER:5V DC 800mA
THIS DEVICE COMPLIES WITH PART 15 OF THE FCC RULES. OPERATION IS SUBJECT TO THE FOLLOWING TWO CONDITIONS:
(1) THIS DEVICE MAY NOT CAUSE HARMFUL INTERFERENCE, AND
(2) THIS DEVICE MUST ACCEPT ANY INTERFERENCE RECEIVED, INCLUDING INTERFERENCE THAT MAY CAUSE UNDESIRE OPERATION.

OVERVIEW

The intercom has a range of 1/2 mile and is able to simultaneously function multi e conversati using a 400-470Mhz secure digital radio link. The intercoms form an exclusive network their by eliminating outside interference.

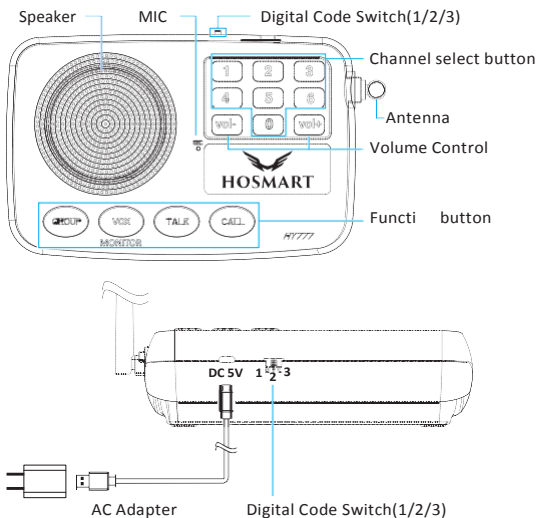

Thank you for your purchase of Hosmart intercom system. This Multi-channel FM wireless intercom is an independent system. You simply plug it in to a standard outlet and you are ready to begin. You will be able to send and receive calls as well as monitor any room that has an intercom installed. Please read the safety and the operating manual before activating the product. Retain all material for future reference. Enjoy!

Operation & Features

Uses radio frequencies of 462 MHz.

Call Button:

Press the "Call" button to notify the other station on the same channel. You will hear a ring tone.

Monitor button(Monitor mode):

Press the Monitor button, this intercom will enter in monitor mode, it will be monitored by other intercoms in the same channel, it can be monitored for 10 hours. Press down the monitor button then the channel number button starts blinking. There is also a red LED indicated when it's transmitting sound from your monitored units. Monitor mode is a one-way communication used to monitor the noise in a specific room.

You also can use the monitor button as a lock function, to make your hands free speaking mode. When press monitor key, intercom will enter the transmission mode continuously. So you can speak to other intercom without any pressing keys. when you finished talking. Press the monitor button again to release the monitor mode.

VOX Mode :

---Voice operated exchange.
Press and hold down the Monitor button for more than 5 seconds. the unit will in VOX mode. it will work in 24hours per day. Press any key can leave the VOX mode.

Talk Button:

Push to talk.
Press and hold down Talk button, the LED indicator lights. you can talk to the other units on the same channel. after talking. you need to release the talk button.

Group Button:

Press this button enter in the Group call mode or conference call mode. You can talk to all of the stations in your home or office. Press and hold Group button to talk. and press and hold Group button to answer.

MIC:

Talk to mic 5-10cm away from it with normal value

Channel number Button:

Set and select which channel you want to call and talk.

Vol-&Vol+ Button:

Volume control. volume + and -.
Please to adjust the volume after talking or ringing. Can't adjust the volume in monitor mode or VOX mode. You can preset the volume in monitor mode or VOX mode.

Power:

---AC adapter with micro USB cable.
It support the voltage from 100V to 250V. FCC certification. Also can support a power bank as a back up battery.

Digital Code Switch(1/2/3):

It can reduce external interference by changing different digital code.
Note:CODE key is on the back of device and beside power port.

WALL INSTALLATION

You may install the intercom anywhere but for the best installation you should mount your intercom close to an AC outlet.

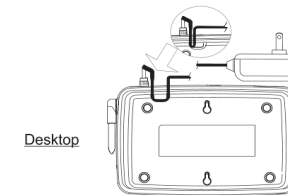
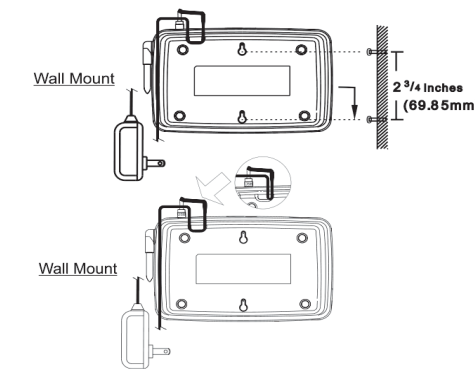

SETTING CHANNEL

Follow these instructions to set up different stations to different channels.

- 1) Press power button to turn on intercom. This will be indicated by the light at channel 1 being activated as well as a beep tone. You may want to adjust sound.
- 2) Press and hold channel 3 button until you hear the beep. Then the channel 3 button lights will activate and you would have successfully designated this station for its current location.
- 3) Once you have designated your home station you will want to label the buttons to the proper room/office for easy reference.

Channel	1	2	3	4
Code	1	1	1	1
Units Location	Bedroom	Barn	Kitchen	Garage

OPERATION

Follow these steps to activate the stations for use.

- 1) The channel button lights will light up when activated. When on, set volume to desired level.

- 2) Establish the appropriate channel for Calling each station as follows:
 *If you want to communicate with the same station then set them to the same channel.
 *If you want to communicate to a separate intercom system then set each station to a different channel.

Calling

- Follow these steps to call/talk
- 1) Press channel button to the proper station you wish to communicate with.
 - 2) Press the call button and a tone will be sent out to the stations on your network.
 - 3) After 1 minute of no usage and the operating channel will return automatically to the home channel.

Talking

Press and hold the talk button and the light will indicate its activation. Once you finish you may release the button. This will allow the recipient to respond.

Receiving

You will hear a tone or the voice of the party that is calling. (Only one party can talk at a time)

Monitor

Press and the Monitor button into be monitored mode. This will allow you to listen in on another station of your choosing. The recipient talk light will be activated during the duration of monitoring.

VOX (The Voice Operating Exchange)

By holding down the Monitor button for more then 5 seconds, you will activate the VOX mode. This will remain until you push any other key to cancel it.

USING ADDITIONAL STATIONS

You may add additional stations to the system as long as they transmit on the same frequency.

CAUTIONS

- The following will help you maintain your wireless intercom for years to come.
- * Keep station from getting wet. It is not waterproof.
 - * Keep stations in a control environment. No extreme temperatures.
 - * Handle the stations with care. No dropping, throwing or roughness.
 - * Keep stations clean from dust and dirt for this can damage the circuit board.
 - * Do not use chemicals or cleaning solvent. Simply use a damp cloth to clean the station.
 - * Modifying or tampering with the stations internal components can cause it to malfunction as well as null your warranty.
- * If your product is not working as advertised then return it to local retailer for assistance or contact us at our e-mail: ellen@hosmart.com

THE FCC WANTS YOU TO KNOW

Your intercom may cause TV or radio interference. To be certain turn off your intercom and check your TV or radio on its performance. If still receiving interference, rest a sure it is not your intercom. You may try to eliminate interference by:

- * Moving your stations further away from the receiver.
- * Moving the stations further away from your TV or radio.

If these options do not solve your problem the FCC requires you to stop using your intercom. Changes or modifications not approved by the party responsible for compliance could void the user authority to operate the equipment.

TROUBLESHOOTING GUIDE

Problem	Possible Solution
Power light does not turn on.	-Is AC power cord connected properly?
Can not receive response.	-Intercom set to proper channel? -Is intercom on monitor mode? -Are you releasing the talk button when you are done speaking? -Is volume turn on?
No communication with other intercom.	-Are the intercoms set to the proper channel? -Did the other party finish talking?
Continuous beeping sound	-Are the intercoms to close causing audio feedback?
Unit does not work.	-Are your walls too thick causing no signal to pass through ?
White noise, can not communicate	-Are all the units set to the same code and channel? Refer to page 9 in the manual -Did you try to change locations by using your mobile phone?

Specifications for Individual units may vary. Specifications are subject to change and improvements without any notice.

UNNECESSARY WHITE NOISE FROM NEAR BY DEVICES: (CTCSS)

1/2/3 Code:
 If receiving unnecessary noise on setting 1 or 3 code. You may switch your intercom system (all unites) setting to 2 or 3 code.

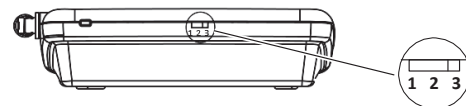

Note:
 Monitor function—For conti talk or room monitoring which can last up to 10 hours.

For any other questions please contact us by E-mail: service@hosmartmall.com

HY777/HY787 FRS Frequencies

CHANNEL	FREQUENCY (MHz)	CODE
1	467.6250	1:DCS 734N; 2:DCS 732N; 3:DCS 731N
2	462.5875	1:DCS 734N; 2:DCS 732N; 3:DCS 731N
3	462.6125	1:DCS 734N; 2:DCS 732N; 3:DCS 731N
4	462.6375	1:DCS 734N; 2:DCS 732N; 3:DCS 731N
5	462.6625	1:DCS 734N; 2:DCS 732N; 3:DCS 731N
6	462.6875	1:DCS 734N; 2:DCS 732N; 3:DCS 731N
0	462.6125	CTCSS CODE: 118.8Hz
GROUP	467.6125	DCS CODE: 627N

LIMITED 12 MONTHS WARRANTY

This product is guaranteed by Hosmart against any manufacturing defects in material and craftsmanship under normal usage for its first 12 months from the date of purchase. Except as provided here in, Hosmart makes no express warranties and any implied warranties, including those by the merchantability as well as fitness for a particular purpose.They are limited to the duration of the written limited warranty contained here in. Except as provided here in, Hosmart shall have no liability or responsibility to customer or any third party with respect to liability, Loss, stolen or damaged caused directly or indirectly by use or performance of the product or arising from breach of this warranty. Including but not limited to any damages sustain from inconvenience, loss of time, data, property, revenue or profit or any indirect special incidental or consequential damages. Even if Hosmart has been advised of the possibility of such damages.

In the event of a product defect during the warranty period, you will take the product along with proof of purchase (receipt) to Hosmart. Hosmart will have the following options:
 (a) Will repair any defect of product free of charge.
 (b) Will replace product with same model or similar design and function.
 (c) If neither of these two options are feasible then Hosmart will refund you the price of the product (at time of purchase). Once refunded all replaced parts of the product and the product it self become once again property of Hosmart.

New or refurbished parts and products may be used during the warranty service. Repaired or replaced parts and products are warranty only for the duration of the original warranty period. You will be charged for repair their after. Contact Customer service:

If you need to mail in the return product to us. Please write down the price and the return date on the outside of the package. This will expedite the process of the returned product and allow for a quicker response in the form of a refund or replacement of the product.

- The warranty does not cover:
- (a) Loss or stolen
 - (b) Normal wear and tear
 - (c) Abuse, dropped or damaged
 - (d) Misuse or tampering
 - (e) Failure to follow instructions
 - (f) Improper installation or maintenance
 - (g) Acts of nature
 - (h) Power surge
 - (i) Any third party repairs done to product that was not authorized by Hosmart will null the warranty.

We hope you had a pleasant shopping experience with us. We appreciate any feedback you may have for we aim for 100% satisfaction. If for any reason you are dissatisfied with our product or our service please feel free to contact us so we may remedy this situation. Thank You!

Office hours:
 Monday thru Friday 9a.m. - 5p.m. (GMT + 8)
 Closed Saturday,Sunday and Public Holidays
 We apologize for any inconvenience or delay reply due to holidays.

U.S.A. Warehouse Address:
 4070 Mission BLVD
 Montclair California 91763
 Vingoo 1039

Made by
 Macross Microelectronics (HK) Limited

Flat/RM KY001 unit 3 27/F Ho King Comm Center
 No.2-16FA Yuen Street Mongkok K1

Phone:(320)-402-6574 ;
 (334)-339-9357

E-mail: service@hosmartmall.com

<https://www.facebook.com/Hosmart-121987695152303/>