

# SR-500 User Manual



Magos Document #: MS9019



## Table of Contents

- 1 Scope ..... 4
  - 1.1 Prefessional Installation instructions ..... 4
  - 1.2 Identification ..... 4
  - 1.3 System Overview ..... 4
- 2 System Description ..... 5
- 3 mechanical instalation guidelines ..... 6
- 4 electrical instalation guidelines ..... 11
  - 4.1 Power supply interface ..... 12
  - 4.2 communication interface ..... 12
- 5 Warnings and disclaimers ..... 13
  - 5.1 general ..... 13
  - 5.2 FCC Compliance Statement ..... 13
  - 5.3 warranty ..... 14
  - 5.4 limitation of liability ..... 14
- 6 Contact ..... 15

## List of Figures

- Figure 1 SR500 sensor outline and dimensions ..... 8
- Figure 2: SR500 Tripod Installation ..... 8
- Figure 3: SR500 Tripod adapter ..... 9
- Figure 4: SR500 Wall Installation ..... 9
- Figure 5 Horizontal mount Bracket ..... 10
- Figure 6 Bracket ..... 10
- Figure 7 SR500 Cable Example ..... 11
- Figure 8 SR500 Cable + Connectors Pinout ..... 11

## List of Tables

**No table of figures entries found.**

## 1 SCOPE

This document aims to provide a user manual for the setup and installation of the SR500 sensor by Magos Systems. The manual provides information on mechanical structure and interface, installation procedure and guidelines, interface to managing system. Please read the entire document prior to the installation and or use of the product.

### 1.1 PREFOSSIONAL INSTALLATION INSTRUCTIONS

- Installation Personnel

The SR500 is designated for installation by technicians/system integrator who have received training by Magosys Ltd. Only. It is **Not** designated for consumer market and installation by “lay-men”. If you have not received proper training please contact Magos Ltd or visit our website ([www.magosys.com](http://www.magosys.com)) for a list of authorized installation personnel.

- Installation Location

The product shall be installed at a location where the radiating antenna can be kept at least 2m from a nearby person in normal operation conditions

- Installation procedure

Please refer to the rest of this manual for further details

### 1.2 IDENTIFICATION

System name: SR500

### 1.3 SYSTEM OVERVIEW

SR500 outdoor perimeter defense sensor is designated for outdoor installation and use only. When connected to a host computer running compatible C&C software it alerts on movement of human/vehicle targets within its coverage area. It provides high accuracy, real-time location and speed data on detected targets.

## 2 SYSTEM DESCRIPTION

SR500 is an autonomous, low energy, high probability of detection sensor for security applications.

Specifications:

- Sensor type: High resolution MIMO digital beam-forming radar
- Detection range: Up to 400m Human & 600m for Vehicle/Boat
- **No moving parts.** MTBF of 100,000 hours.
- Azimuth coverage: 120°
- Elevation coverage: 30°
- Azimuth accuracy: 1°
- Frequency: 5.8GHz
- Range resolution: 0.4m
- Scan rate: 2 scans per second
- Detected target speed: 0.3 – 30m/sec.
- False alarm rate: <1 per day
- Power: 15-32V, <2.5W, peak power <10w.
- Built in tracker – low data bandwidth (<1kbps)
- Interface: UDP based Ethernet
- Dimensions 9.8"(w) x 5.8"(h) x 2.3"(d)
- Weight: 3.3 Pounds
- IP67
- FCC & CE compliant.

### 3 MECHANICAL INSTALATION GUIDELINES

The SR500 radar sensor is very simple to handle and install.

Using the four holes on the back, the unit may be assembled either using one of Magos' solutions or any other means of securing the unit in the desired location.

General guidelines for assembly:

- Figure 1 outlines the mechanical dimensions of the unit and mounting holes, the electronic connector location and the product "front". Holes are compatible to 1/4"-20X1/2 screws. Figure 2 and Figure 4 depict the product installation orientation. Note that product must be installed such that the product "front" face is aimed towards the horizon, perpendicular to the ground. Screws and mounting brackets can be purchased separately from Magosys. The brackets and their use are depicted in: Figure 4, Figure 5 and Figure 6.
- When using Magosys' brackets or any other bracket ensure all 4 screws are used. During installation make sure all screws are properly fastened, and are installed with spring washers and washers. Otherwise Magosys is not responsible to damage caused to the unit or people resulting from the detachment of the sensor unit under harsh wind conditions.
- Carefully choose the area of installation: make sure that the coverage area of the unit is a sparsely populated area with minimum human traffic. In addition avoid installing the unit in the vicinity of large metal (or other) reflectors that might block line of sight to the entire coverage area or otherwise hamper sensor performance. If you are uncertain as to the ideal sensor location contact Magosys for assistance in position.
- Aim the center of the sensor towards the center of the area of interest, make sure that sensor is level with ground, otherwise sensor coverage area might be reduce according to sensor's elevation angle coverage.
- Recommended installation height is 3-9m. Bellow 3m user might experience degradation in sensor performance. Above 9m there might be a "dead-zone" in the vicinity of the sensor in accordance with the sensor's elevation angle coverage.
- Make sure the sensor is stable and secure. The mounting solution should be stiff and stationary under harsh wind conditions. As a general guideline, oscillations of more than 3cm should not be allowed, or the unit's performance might be compromised.
- If several sensors need to be installed next to each other, we recommend a distance of at least 1m between the sensors when not aimed at each other (back to back installation). Avoid aiming the sensors at each other when they are installed with less than 150 meters distance between them.

Failure to observe the above restrictions might result in sensor performance degradation and in extreme cases might lead to irreversible damage to the sensor units.

- Connecting to the sensor: use outdoor weather immune cables. When cable is not plugged in use the connector cap to maintain weather immunity. Magosys is not responsible to weather damage (corrosion etc.) caused by using improper cables/failure to use the cap when not installed. In such cases product warranty is void. See chapter 4 for details on sensor electronic connection.

Ensure that the electronic connecting cable is firmly secured to the pole/wall or any other

contraption upon which the radar is installed in such a fashion that would not allow it to dangle within the coverage area of the sensor. In addition make sure that the cable securing method renders it resistible to strong winds and that it does not apply excessive force on the connector.

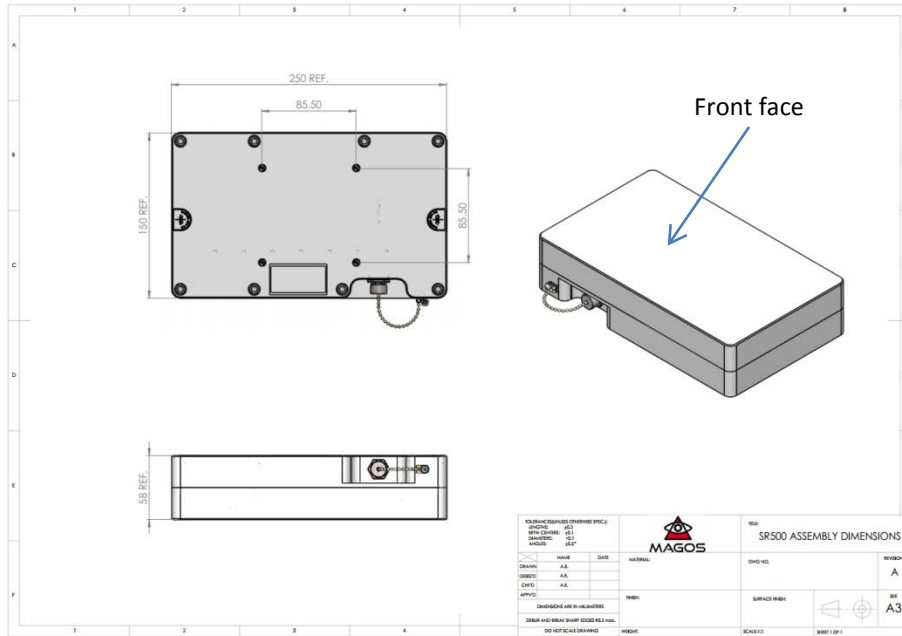

Figure 1 SR500 sensor outline and dimensions

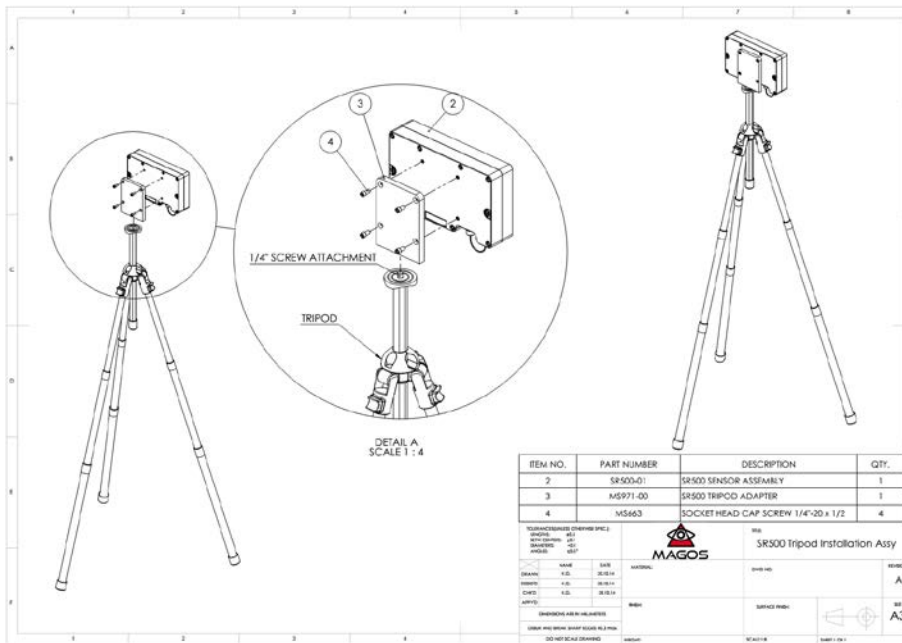
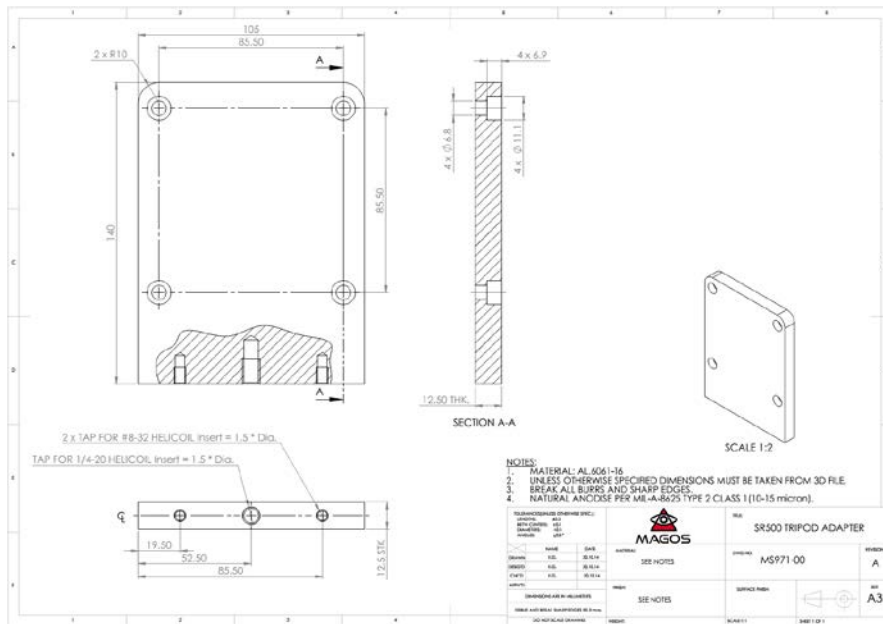
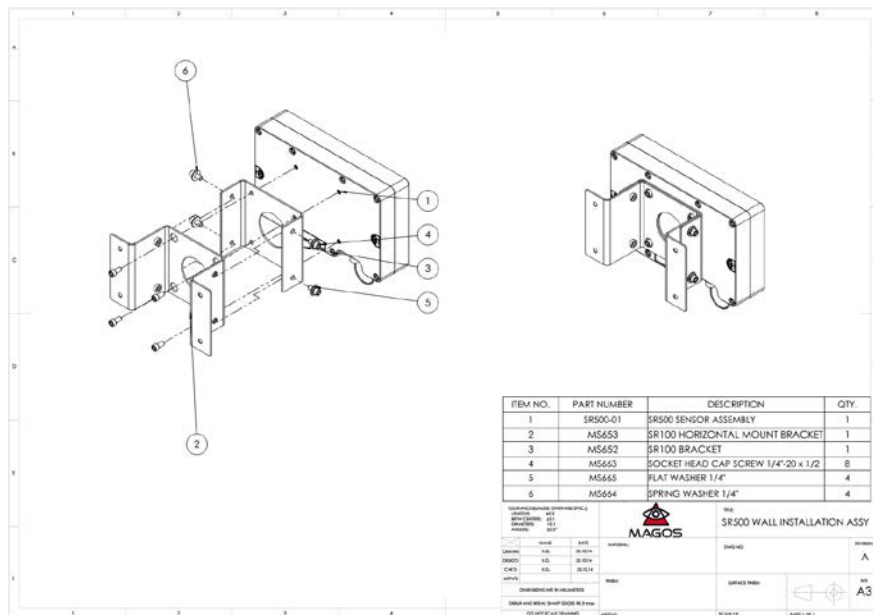

Figure 2: SR500 Tripod Installation





**Figure 3: SR500 Tripod adapter**



**Figure 4: SR500 Wall Installation**

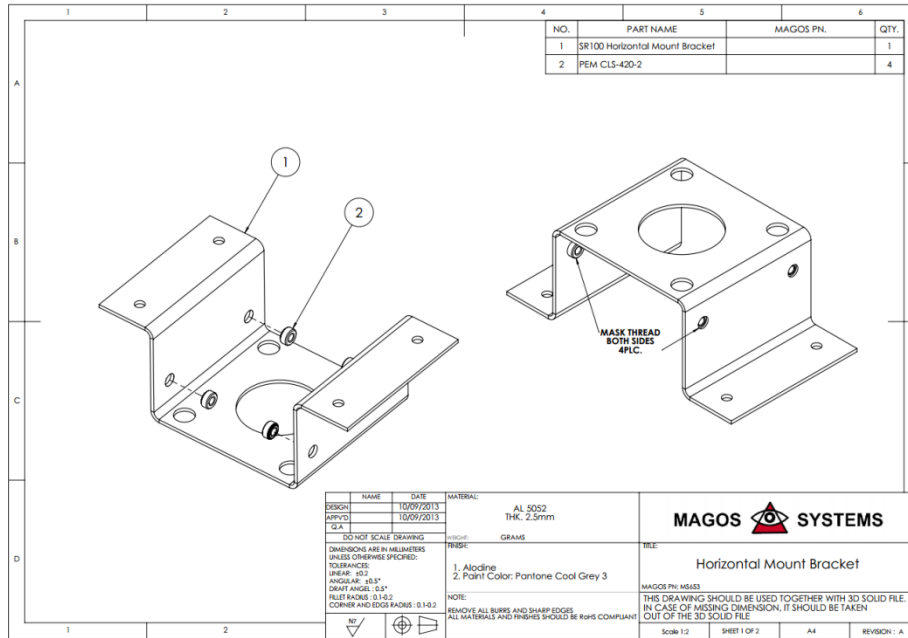

Figure 5 Wall/Pole mount Bracket

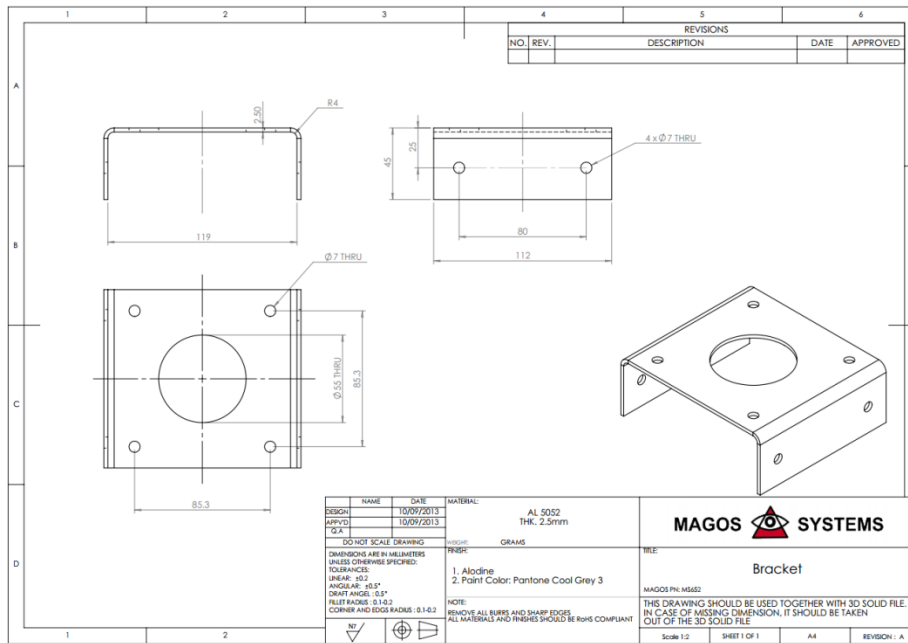

Figure 6 SR500 Bracket

**4 ELECTRICAL INSTALATION GUIDELINES**

Electrical installation of the sensor consists of a simple cable connection on the radar side. Depending on the sensor model, the interface required and the available on-site infrastructure the user can choose to prepare custom made cables or use Magosys cables that are supplied separately. Cable examples are depicted in Figure 7. For your convenience in case of the custom cable option, cable and connector pinout is depicted in Figure 8.

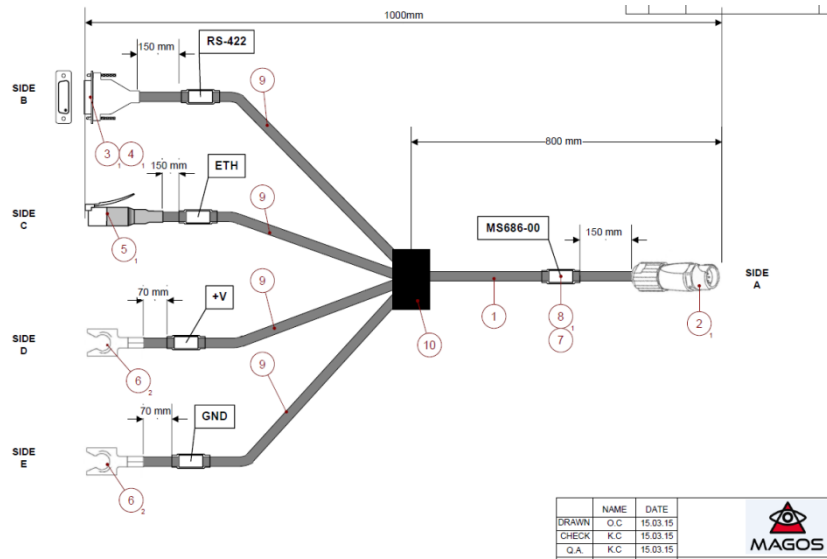

Figure 7 SR500 Cable Example

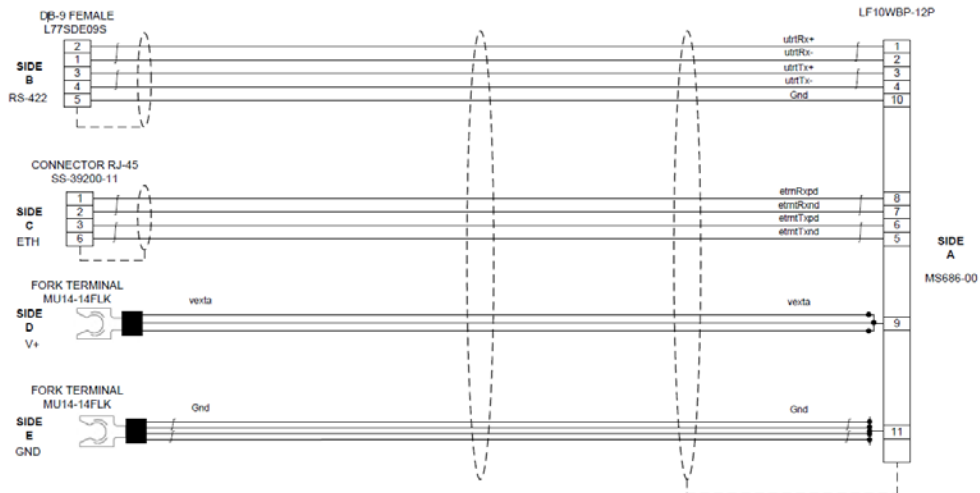

Figure 8 SR500 Cable + Connectors Pinout

#### 4.1 POWER SUPPLY INTERFACE

Ensure that the power supply used with the SR-500 is in conformance with all safety and EMC standards that are relevant and applicable in your country. If you are unfamiliar with such standards it is recommended that you contact Magosys and enquire as to the compatibility of the suggested power supply.

Electrical requirements of the power supply are 15-35[V] and 2[A] minimum. Using power supplies that do not meet these requirements and or are not properly authorized for public use in your country is under the sole responsibility of the user, and might result in unexpected sensor behavior or even irreversible damage to the unit.

#### 4.2 COMMUNICATION INTERFACE

The SR500 sensor supports standard ethernet interface. The product label contains it's unique MAC address. When interfacing Magosys propriety MASS C&C software consult with the MASS user manual for more details on sersor interface and ICD.

Otherwise please contact Magosys at [info@magosys.com](mailto:info@magosys.com) for information on supported C&C software, sensor setup etc.

## 5 WARNINGS AND DISCLAIMERS

### 5.1 GENERAL

1. The SR500 is an electronic radiating product. As such it is not recommended for installation with densely populated areas, or in the vicinity of such areas. Magosys recommends installation at remote, unpopulated, outdoor sites only. In addition avoid prolonged un-necessary human contact with the radar and as a rule it is recommended that the installation with maintain a 3m radius safety distance from the sensor.
2. The SR500 is not intended for direct connection to the AC power network. When using power supplies/converters with the radar, that are connected to a local or national AC power network make sure they are properly isolated and are in full compliance with you local regulations. In any event Magos will not liable to any damage caused to the product or any interference caused to the power network resulting from a faulty/in-appropriate power supply.
3. Mechanical installation of the SR500 is not within the scope of responsibility of Magos. Magos is not liable to any damage incurred to the customer and/or to a third party due to faulty installation (loose bolting/weak brakets etc).

### 5.2 FCC COMPLIANCE STATEMENT

This device has been tested and found to comply with the limits for a Class B digital device, pursuant to Part 15 of the FCC Rules. These limits are designed to provide reasonable protection against harmful interference in residential installations. This equipment generates uses and can radiate radio frequency energy and, if not installed and used in accordance with the instructions, may cause harmful interference to radio and television reception.

However, there is no guarantee that interference will not occur in a particular installation. If this device does cause such interference, which can be verified by turning the device off and on, the user is encouraged to eliminate the interference by one or more of the following measures:

- Re-orient or re-locate the receiving antenna.
- Increase the distance between the device and the receiver.
- Connect the device to an outlet on a circuit different from the one that supplies power to the receiver.
- Consult the dealer or an experienced radio/TV technician.

**WARNING! Changes or modifications to this unit not expressly approved by the party responsible for compliance could void the user's authority to operate the equipment.**

To comply with FCC Section 1.1310 for human exposure to radio frequency electromagnetic fields, implement the following instruction:

A distance of at least 10 cm. between the equipment and all persons should be maintained during the operation of the equipment.

### 5.3 WARRANTY

Unless otherwise agreed upon Magos supplies 1 year warranty from date of purchase.

The product warranty extends to the original purchaser only and is not transferable.

The product warranty does not apply to software programs, power supplies, cables, brackets or other accessories supplied with the product.

Transport in case of a malfunction that requires maintenance at Magosys premises in under the responsibility of the customer.

Magos Ltd does not have any liability or responsibility under the Product Warranty where any cost, loss, injury or damage of any kind, whether direct, indirect, consequential, incidental or otherwise arises out of events beyond Magos's reasonable control. This includes but is not limited to: acts of God, war, riot, embargoes, acts of civil or military authorities, fire, floods, electricity outages, lightning, power surges, or shortages of materials or labour.

The product warranty is automatically voided if:

- You or anyone else use the product or attempt to use it other than as specified by Magos;
- The fault/defect in your product is the result of a voltage surge subjected to the product either by the way of power supply or communication line, whether caused by thunderstorm activity or any other cause;
- The fault is the result of accidental damage in transit, including but not limited to liquid spillage;
- Your product has been used for any purposes other than that for which it is sold, or in any way other than in strict accordance with the user manual supplied;
- Your product has be repaired or modified or attempted to be repair or modified or tampered with by anyone other than a person qualified to do so by Magsys. Specifically opening the product cover or any of the cover fastening screws will be considered as tampering described in this section;
- The serial number label has been defaced or altered in any way or removed.

### 5.4 LIMITATION OF LIABILITY

Magosys accepts no liability or responsibility, for consequences arising from the use of this product.

Specifically, although this is a security device, under no circumstances is Magos responsible or liable to direct/indirect damages and or costs caused/inflicted to the customer or a third party as a result of false alarms, missed detections, or inaccurate sensor readings. Though the SR500 is top of the line technology

and in most scenarios the best security sensor in terms of detection performance it is not 100% fault proof and must not be treated as such.

Magos reserves the right to change the specifications and operating details of this product without notice.

If any law implies a guarantee, condition or warranty in respect of goods or services supplied, and Magosys's liability for breach of that condition or warranty may not be excluded but may be limited, then subject to your rights and remedies under any applicable Consumer Protection Laws which cannot be excluded, Magosys's liability for any breach of that guarantee, condition or warranty is limited to: (i) in the case of a supply of goods. Magosys doing any one or more of the following: replacing the goods or supplying equivalent goods; repairing the goods; paying the cost of replacing the goods or of acquiring equivalent goods; or paying the cost of having the goods repaired; or (ii) in the case of a supply of services, Magos doing either or both of the following: supplying the services again; or paying the cost of having the services supplied again.

To the extent Magos is unable to limit its liability as set out above, Magos limits its liability to the extent such liability is lawfully able to be limited.

## 6 CONTACT

Address: Magos Ltd.

Gad Feistein 13, Rehovot, Israel

Phone: +972 (0)77 414 0155

Fax: +972 (0)77 414 0165

Email: [info@magosys.com](mailto:info@magosys.com)

Or visit our website at: [www.magosys.com](http://www.magosys.com)