



# Recipro Saw

**MODEL JR3030**  
Variable Speed

**MODEL JR3030T**  
Variable Speed

## INSTRUCTION MANUAL

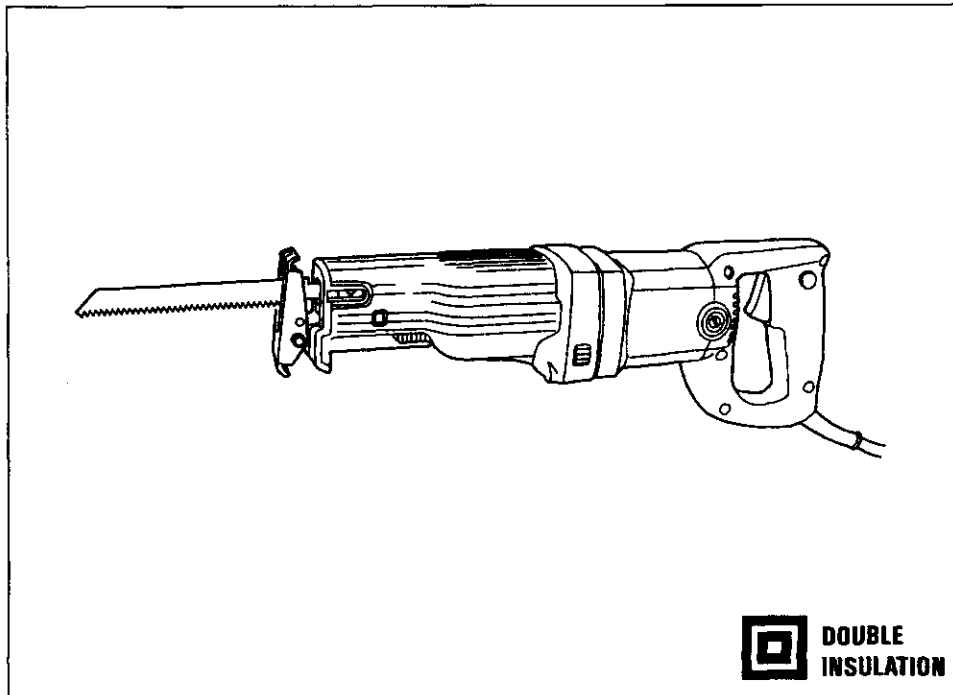

### SPECIFICATIONS

Model	Length of stroke	Strokes per minute	Overall length	Net weight
JR3030	28 mm (1-3/32")	0 - 2,600	438 mm (17-1/4")	3.5 kg (7.7 lbs)
JR3030T			460 mm (18-1/8")	

\* Manufacturer reserves the right to change specifications without notice.

• Note: Specifications may differ from country to country.

**WARNING:** For your personal safety, READ and UNDERSTAND before using.

**SAVE THESE INSTRUCTIONS FOR FUTURE REFERENCE.**

# GENERAL SAFETY RULES

(For All Tools)

**WARNING! Read and understand all instructions.** Failure to follow all instructions listed below, may result in electric shock, fire and/or serious personal injury.

## SAVE THESE INSTRUCTIONS

### READ ALL INSTRUCTIONS.

#### WORK AREA

1. **Keep your work area clean and well lit.** Cluttered benches and dark areas invite accidents.
2. **Do not operate power tools in explosive atmospheres, such as in the presence of flammable liquids, gases, or dust.** Power tools create sparks which may ignite the dust or fumes.
3. **Keep bystanders, children, and visitors away while operating a power tool.** Distractions can cause you to lose control.

#### ELECTRICAL SAFETY

4. **Double Insulated tools are equipped with a polarized plug (one blade is wider than the other.) This plug will fit in a polarized outlet only one way. If the plug does not fit fully in the outlet, reverse the plug. If it still does not fit, contact a qualified electrician to install a polarized outlet. Do not change the plug in any way. Double insulation  eliminates the need for the three wire grounded power cord and grounded power supply system.**
5. **Avoid body contact with grounded surfaces such as pipes, radiators, ranges and refrigerators.** There is an increased risk of electric shock if your body is grounded.
6. **Don't expose power tools to rain or wet conditions.** Water entering a power tool will increase the risk of electric shock.
7. **Do not abuse the cord. Never use the cord to carry the tools or pull the plug from an outlet. Keep cord away from heat, oil, sharp edges or moving parts. Replace damaged cords immediately. Damaged cords increase the risk of electric shock.**
8. **When operating a power tool outside, use an outdoor extension cord marked "W-A" or "W."** These cords are rated for outdoor use and reduce the risk of electric shock.

#### PERSONAL SAFETY

9. **Stay alert, watch what you are doing and use common sense when operating a power tool. Do not use tool while tired or under the influence of drugs, alcohol, or medication.** A moment of inattention while operating power tools may result in serious personal injury.
10. **Dress properly. Do not wear loose clothing or jewelry. Contain long hair. Keep your hair, clothing, and gloves away from moving parts.** Loose clothes, jewelry or long hair can be caught in moving parts.

11. **Avoid accidental starting. Be sure switch is off before plugging in.** Carrying tools with your finger on the switch or plugging in tools that have the switch on invites accidents.
12. **Remove adjusting keys or switches before turning the tool on.** A wrench or a key that is left attached to a rotating part of the tool may result in personal injury.
13. **Do not overreach. Keep proper footing and balance at all times.** Proper footing and balance enables better control of the tool in unexpected situations.
14. **Use safety equipment. Always wear eye protection.** Dust mask, non-skid safety shoes, hard hat, or hearing protection must be used for appropriate conditions.

#### **TOOL USE AND CARE**

15. **Use clamps or other practical way to secure and support the workpiece to a stable platform.** Holding the work by hand or against your body is unstable and may lead to loss of control.
16. **Do not force tool. Use the correct tool for your application.** The correct tool will do the job better and safer at the rate for which it is designed.
17. **Do not use tool if switch does not turn it on or off.** Any tool that cannot be controlled with the switch is dangerous and must be repaired.
18. **Disconnect the plug from the power source before making any adjustments, changing accessories, or storing the tool.** Such preventive safety measures reduce the risk of starting the tool accidentally.
19. **Store idle tools out of reach of children and other untrained persons.** Tools are dangerous in the hands of untrained users.
20. **Maintain tools with care. Keep cutting tools sharp and clean.** Properly maintained tools, with sharp cutting edges are less likely to bind and are easier to control.
21. **Check for misalignment or binding of moving parts, breakage of parts, and any other condition that may affect the tools operation. If damaged, have the tool serviced before using.** Many accidents are caused by poorly maintained tools.
22. **Use only accessories that are recommended by the manufacturer for your model.** Accessories that may be suitable for one tool, may become hazardous when used on another tool.

#### **SERVICE**

23. **Tool service must be performed only by qualified repair personnel.** Service or maintenance performed by unqualified personnel could result in a risk of injury.
24. **When servicing a tool, use only identical replacement parts. Follow instructions in the Maintenance section of this manual.** Use of unauthorized parts or failure to follow Maintenance Instructions may create a risk of electric shock or injury.







## ***Specific Safety Rules***

- 1. Hold tool by insulated gripping surfaces when performing an operation where the cutting tool may contact hidden wiring or its own cord. Contact with a "live" wire will also make exposed metal parts of the tool "live" and shock the operator.**
- 2. Avoid cutting nails. Inspect workpiece for any nails and remove them before operation.**
- 3. Do not cut oversize workpiece.**
- 4. Check for the proper clearance beyond the workpiece before cutting so that the blade will not strike the floor, workbench, etc.**
- 5. Hold the tool firmly.**
- 6. Make sure the blade is not contacting the workpiece before the switch is turned on.**
- 7. Keep hands away from moving parts.**
- 8. Do not leave the tool running. Operate the tool only when hand-held.**
- 9. Always switch off and wait for the blade to come to a complete stop before removing the blade from the workpiece.**
- 10. Do not touch the blade or the workpiece immediately after operation; they may be extremely hot and could burn your skin.**

**SAVE THESE INSTRUCTIONS.**

# SYMBOLS

The followings show the symbols used for tool.

V	.....	volts
A	.....	amperes
Hz	.....	hertz
kg	.....	kilograms
h	.....	hours
min	.....	minutes
s	.....	seconds
	.....	alternating current
	.....	direct current
$n_0$	.....	no load speed
	.....	alternating or direct current
	.....	Class II Construction
	.....	splash-proof construction
	.....	watertight construction
.../min	.....	revolutions or reciprocation per minute
	.....	number of blow

## FUNCTIONAL DESCRIPTION

### Adjusting shoe

When the blade loses its cutting efficiency in one place along its cutting edge, reposition the shoe to utilize a sharp, unused portion of its cutting edge. This will help to lengthen the life of the blade. To reposition the shoe, loosen the lever and slide the shoe forward or back to the desired position. Then tighten the lever to firmly secure the shoe.

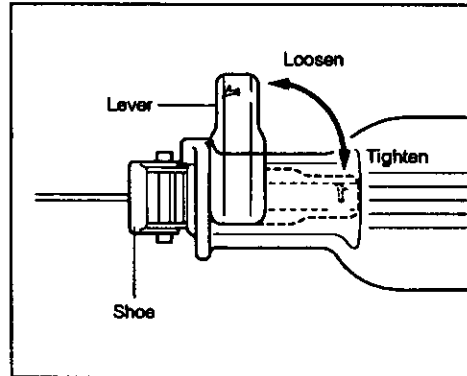

### Switch action

#### CAUTION:

Before plugging in the tool, always check to see that the switch trigger actuates properly and returns to the "OFF" position when released.

To start the tool, simply pull the trigger. Tool speed is increased by increasing pressure on the trigger. Release the trigger to stop. For continuous operation, pull the trigger and then push in the lock button. To stop the tool from locked position, pull the trigger fully, then release it.

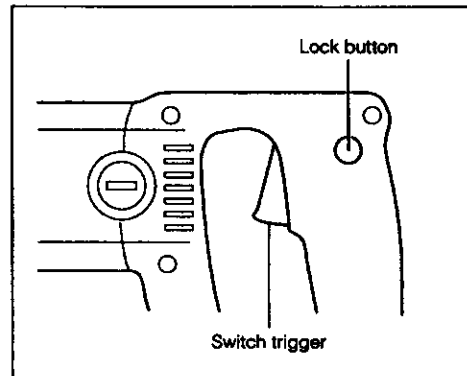

## ASSEMBLY

### Installing or removing the saw blade

#### CAUTION:

- Always be sure that the tool is switched off and unplugged before installing or removing the blade.
- Always clean out all chips or foreign matter adhering to the blade, blade clamp and/or slider. Failure to do so may cause insufficient tightening of the blade, resulting in a serious injury.

#### For JR3030

To install the blade, loosen the screw on the blade clamp with the hex wrench 4 provided. Insert the blade between the blade clamp and the slider so that the pin on the slider fits into the hole in the blade shank. If the pin cannot easily fit into the hole, remove the hex wrench from the screw and then try again. After the pin fits properly into the hole, tighten the screw securely while making sure that the blade cannot be extracted even though you try to pull it out.

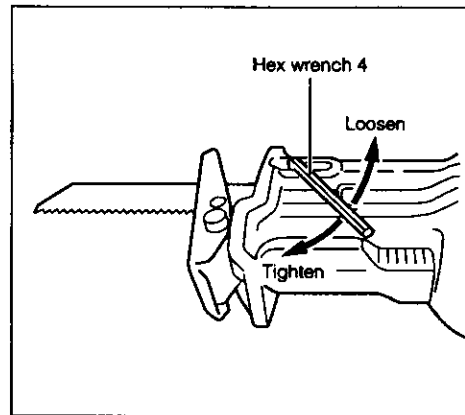

#### CAUTION:

If you tighten the screw without the pin on the slider fitting properly in the hole in the blade shank, the pin or the blade shank will be damaged. This may cause the blade to be ejected unexpectedly during operation. This can be extremely dangerous.

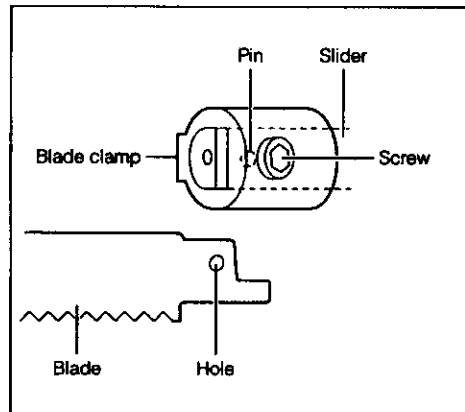

To install the blade, loosen the screw on the blade clamp with the hex wrench 4.

**For JR3030T**

To install the blade, push the push button in the direction of the arrow and insert the blade between the blade clamp and the slider as far as it will go. Then release the push button and make sure that the blade cannot be extracted even though you try to pull it out.

**CAUTION:**

If you release the push button without inserting the blade deep enough, the blade may be ejected unexpectedly during operation. This can be extremely dangerous.

To remove the blade, push the push button in the direction of the arrow and pull out the blade.

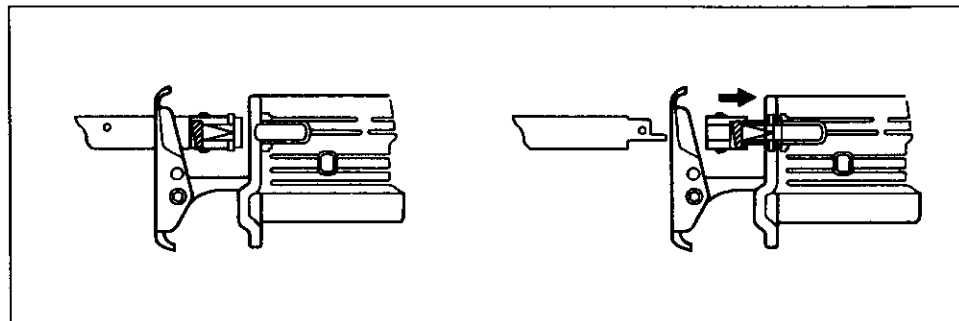
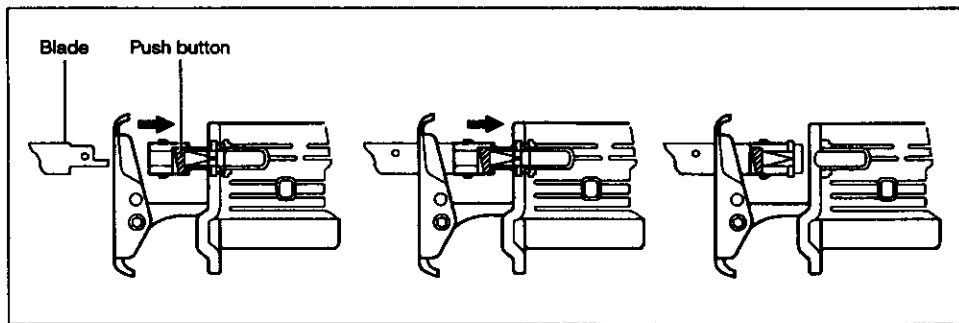



## **OPERATION**

Press the shoe firmly against the workpiece. Do not allow the tool to bounce. Bring the blade into light contact with the workpiece. First, make a pilot groove, using a slower speed. Then use a faster speed to continue cutting.

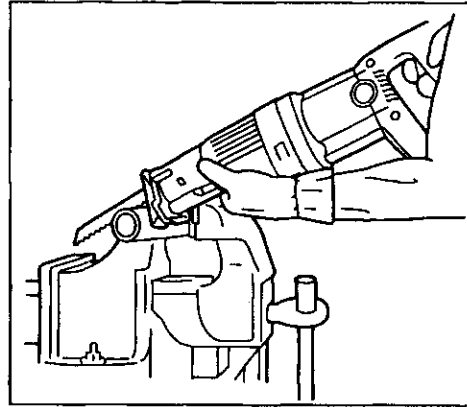

## **CAUTION:**

- Always use a suitable coolant (cutting oil) when cutting metal. Failure to do so will cause premature blade wear.
- Always wear gloves to protect your hands from hot flying chips when cutting metal.
- Always press the shoe firmly against the workpiece during operation. If the shoe is held away from the workpiece during operation, strong vibration and/of twisting will be produced, causing the blade to snap dangerously.
- Be sure to always wear suitable eye protection which conforms with current national standards.

## MAINTENANCE

### CAUTION:

Always be sure that the tool is switched off and unplugged before attempting to perform inspection or maintenance.

### Replacing carbon brushes

Remove and check the carbon brushes regularly. Replace when they wear down to the limit mark. Keep the carbon brushes clean and free to slip in the holders. Both carbon brushes should be replaced at the same time. Use only identical carbon brushes.

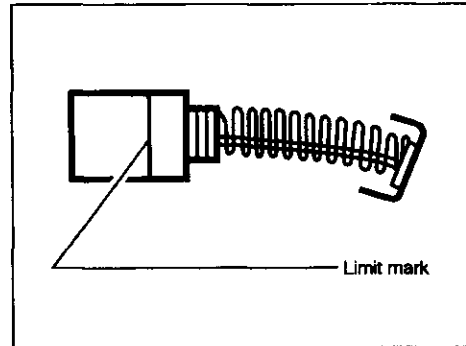

Use a screwdriver to remove the brush holder caps. Take out the worn carbon brushes, insert the new ones and secure the brush holder caps.

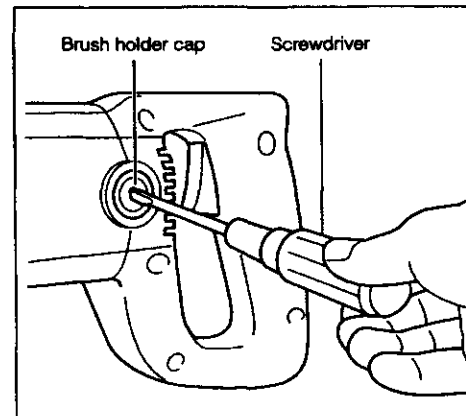



To maintain product SAFETY and RELIABILITY, repairs, any other maintenance or adjustment should be performed by Makita Authorized or Factory Service Centers, always using Makita replacement parts.

## ACCESSORIES

### CAUTION:

These accessories or attachments are recommended for use with your Makita tool specified in this manual. The use of any other accessories or attachments might present a risk of injury to persons. These accessories or attachments should be used only in the proper and intended manner.

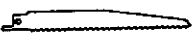
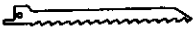
NOTE: The accessories listed in this manual are available at the extra cost from your Makita distributor or Makita Factory Service Center. Service Centers are listed on the warranty card packed with your tool.

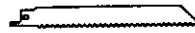
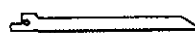
Saw Blades	Part #	Qty Per Pkg	Teeth Per Inch	Overall Length	Tooth Specifications	Application
<b>Wood Cutting Blades</b>      	723018-A-5 723018-A-2	5 2	6 6	6" 6"	High Carbon Steel Fleam Ground (0.049")	Cuts nail free wood — rough in work.
	723018-B-5 723018-B-1	5 1	6 6	12" 12"	High Carbon Steel Fleam Ground (0.049")	Cuts nail free wood — rough in work.
	723018-C-5	5	6	6"	High Alloy Steel Milled (0.031")	Cuts composition materials — resists nail damage.
	723018-D-5 723018-D-2	5 2	10 10	6" 6"	High Alloy Steel Milled (0.031")	Cuts composition & plywood — resists nail damage.
	723018-E-5	5	6	6"	High Carbon Steel Fleam Ground (0.049")	Cuts circles and contours in nail free wood, compositions.
	723018-P-5	5	6	6"	High Alloy Steel M/V Alternate (0.041")	Cuts plaster, metal lath, plasterboard.
	<b>Metal Cutting Blades</b>  For rapid cutting of metal and fiberglass. Made of high speed steel.    	723019-G-5 723019-G-2	5 2	14 14	4" 4"	High Speed Steel Milled/Raker Set (0.031")
723019-A-5 723019-A-2		5 2	14 14	6" 6"	High Speed Steel Milled/Raker Set (0.031")	For cutting metal over 1/8" thick.
723019-B-5 723019-B-2		5 2	18 18	4" 4"	High Speed Steel Milled/Raker Set (0.031")	For cutting metal over 3/64" thick.
723019-H-5		5	18	4"	High Speed Steel Milled/Wavy Set (0.049")	For scroll cuts in metal 3/64" thick and over.
723019-C-5 723019-C-2		5 2	18 18	6" 6"	High Speed Steel Milled/Raker Set (0.031")	For cutting metal over 3/64" thick.
723019-K-5 723019-K-2		5 2	24 24	4" 4"	High Speed Steel Milled/Wavy Set (0.031")	For cutting metal less than 3/64" thick.
723019-D-5 723019-D-2		5 2	24 24	6" 6"	High Speed Steel Milled/Wavy Set (0.031")	For cutting metal less than 3/64" thick.
723019-J-5		5	36	4"	High Speed Steel Milled/Wavy Set (0.031")	For cutting metal less than 1/32" thick.

Note: All illustrations shown are general representations for blades in that category. Actual design of blades may vary slightly.

**ACCESSORIES** *continued-*

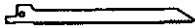
Saw Blades	Part #	Qty Per Pkg	Teeth Per Inch	Overall Length	Tooth Specifications	Application
<b>Bi-metal Blades</b> Combination of high speed steel teeth welded to a shatter-proof, flexible backed blade. Ultra-long life blade.  	723017-E-5 723017-E-2	5 2	6 6	6" 6"	Bi-metal Milled (0.050")	Cuts nail embedded wood – roughing in work.
	723017-F-5	5	6	12"	Bi-metal milled (0.050")	Cuts nail embedded wood – roughing in work.
	723017-A-5 723017-A-2	5 2	10 10	6" 6"	Bi-metal Milled (0.031")	Cuts nail embedded wood – nonferrous metals.
	723017-G-5	5	14	4"	Bi-metal Milled (0.031")	Cuts metal 1/8" thick and over.
	723017-B-5 723017-B-2	5 2	14 14	6" 6"	Bi-metal Milled (0.031")	Cuts metal 1/8" thick and over.
	723017-H-5 723017-H-2	5 2	18 18	4" 4"	Bi-metal Milled (0.031")	Cuts metal 3/64" thick and over.
	723017-C-5 723017-C-2	5 2	18 18	6" 6"	Bi-metal Milled (0.031")	Cuts metal 3/64" thick and over.
	723017-K-5	5	18	3-1/2"	Bi-metal Milled (0.031")	Scroll cuts in metals over 3/64" thick, fiber-glass, compositions.
	723017-J-5 723017-J-2	5 2	24 24	4" 4"	Bi-metal Milled (0.031")	Cuts metal less than 3/64" thick.
	723017-D-5 723017-D-2	5 2	24 24	6" 6"	Bi-metal Milled (0.031")	Cuts metal less than 3/64" thick.

**3 Piece Variety Pack**

Wood and Metal Cutting  
 includes 1 each: 723018-A  
 723018-D  
 723019-C

This pack is available under  
 Part No. 723016-3-A

**3 Piece Variety Pack**

Ultra Long Life Bi-metal  
 includes 1 each: 723017-E  
 723017-B  
 723017-C

This pack is available under  
 Part No. 723016-3-B

• **Plastic Tool Case**

• **Hex Wrench 4 (For Model JR3030)**

Part No. 783202-0

Accommodated tool with 6" blade.

# RECIPRO SAW Model JR3030

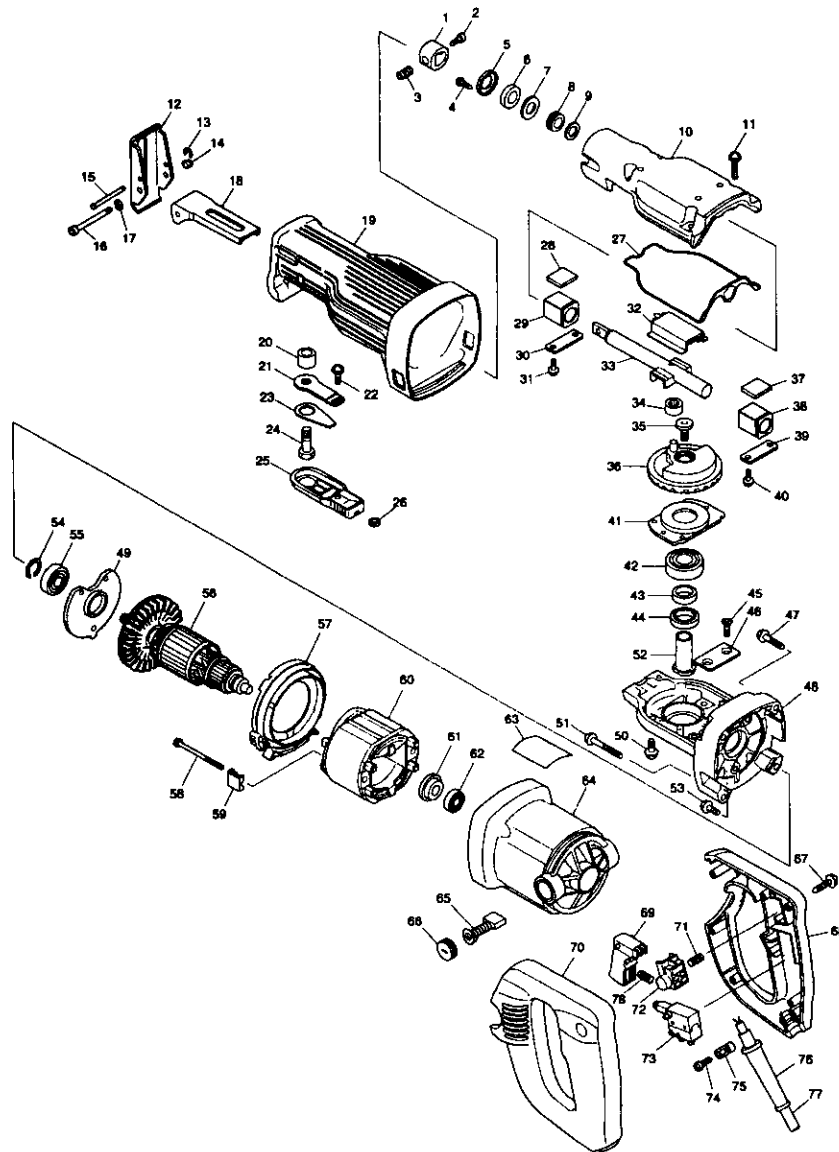

Note: The switch and other part configurations may differ from country to country.

ITEM NO.	NO. USED	DESCRIPTION	ITEM NO.	NO. USED	DESCRIPTION
<b>MACHINE</b>			<b>MACHINE</b>		
1	1	Blade Clamp	40	2	Pan Head Screw M5x16
2	1	Hex. Socket Head Bolt M5x15	41	1	Bearing Retainer 56
3	1	Screw M8x10	42	1	Ball Bearing 6202LLB
4	2	Tapping Screw Bind CT 5x12	43	1	Ring 15
5	1	Felt Retainer	44	1	Ball Bearing 6902
6	1	Felt Ring 14	45	2	Hex. Socket Head Bolt M5x12
7	1	Flat Washer 14	46	1	Plate (C)
8	1	X Ring 14	47	2	Tapping Screw 5x30
9	1	Flat Washer 16	48	1	Gear Housing
10	1	Gear Housing Cover	49	1	Bearing Retainer
11	4	Pan Head Screw M5x30	50	3	Pan Head Screw M5x8
12	1	Shoe Plate	51	2	Tapping Screw 5x45
13	1	Stop Ring E-3	52	1	Gear Shaft
14	1	Hex. Lock Nut M5-8	53	3	Pan Head Screw M5x8
15	1	Pin 4	54	1	Retaining Ring S-12
16	1	Hex. Socket Bolt M5x45	55	1	Ball Bearing 6001DDW
17	1	Spring Washer 5	56	1	ARMATURE ASSEMBLY (With Item 61 & 62)
18	1	Shoe Supporter	57	1	Baffle Plate
19	1	Insulation Cover	58	2	Tapping Screw 5x60
20	1	Sleeve 9	59	2	Retainer
21	1	Inner Plate	60	1	FIELD ASSEMBLY
22	1	Pan Head Screw M4x10	61	1	Insulated Washer
23	1	Lock Plate	62	1	Ball Bearing 608DDW
24	1	Hex. Bolt M8x25	63	1	Name Plate
25	1	Lever 60	64	1	Motor Housing Complete
26	1	Hex. Nut M4	65	2	Carbon Brush
27	1	Packing	66	2	Brush Holder Cap
28	1	Plate 12x16	67	5	Tapping Screw 4x20
29	1	Plane Bearing 14	68	1	Handle Set (With Item 70)
30	1	Plate	69	1	Switch Lever
31	2	Pan Head Screw M5x16	70	1	Handle Set (With Item 68)
32	1	Slide Plate	71	1	Compression Spring 4
33	1	Slider	72	1	Lock-Off Button
34	1	Needle Bearing 708	73	1	Switch
35	1	Hex. Socket Head Bolt M10x18	74	2	Tapping Screw 4x18
36	1	Gear Complete	75	1	Strain Relief
37	1	Plate 12x16	76	1	Cord Guard
38	1	Plane Bearing 14	77	1	Cord
39	1	Plate	78	1	Compression Spring 5

Note: The switch and other part specifications may differ from country to country.

AMERICA

## MAKITA LIMITED ONE YEAR WARRANTY

### Warranty Policy

Every Makita tool is thoroughly inspected and tested before leaving the factory. It is warranted to be free of defects from workmanship and materials for the period of ONE YEAR from the date of original purchase. Should any trouble develop during this one-year period, return the COMPLETE tool, freight prepaid, to one of Makita's Factory or Authorized Service Centers. If inspection shows the trouble is caused by defective workmanship or material, Makita will repair (or at our option, replace) without charge.

This Warranty does not apply where:

- repairs have been made or attempted by others;
- repairs are required because of normal wear and tear;
- The tool has been abused, misused or improperly maintained;
- alterations have been made to the tool.

IN NO EVENT SHALL MAKITA BE LIABLE FOR ANY INDIRECT, INCIDENTAL OR CONSEQUENTIAL DAMAGES FROM THE SALE OR USE OF THE PRODUCT. THIS DISCLAIMER APPLIES BOTH DURING AND AFTER THE TERM OF THIS WARRANTY.

MAKITA DISCLAIMS LIABILITY FOR ANY IMPLIED WARRANTIES, INCLUDING IMPLIED WARRANTIES OF "MERCHANTABILITY" AND "FITNESS FOR A SPECIFIC PURPOSE," AFTER THE ONE-YEAR TERM OF THIS WARRANTY.

This Warranty gives you specific legal rights, and you may also have other rights which vary from state to state. Some states do not allow the exclusion or limitation of incidental or consequential damages, so the above limitation or exclusion may not apply to you. Some states do not allow limitation on how long an implied warranty lasts, so the above limitation may not apply to you.

**Makita Corporation of America**  
2650 Buford Hwy., Buford, GA 30518

884230 - 061

PRINTED IN USA