

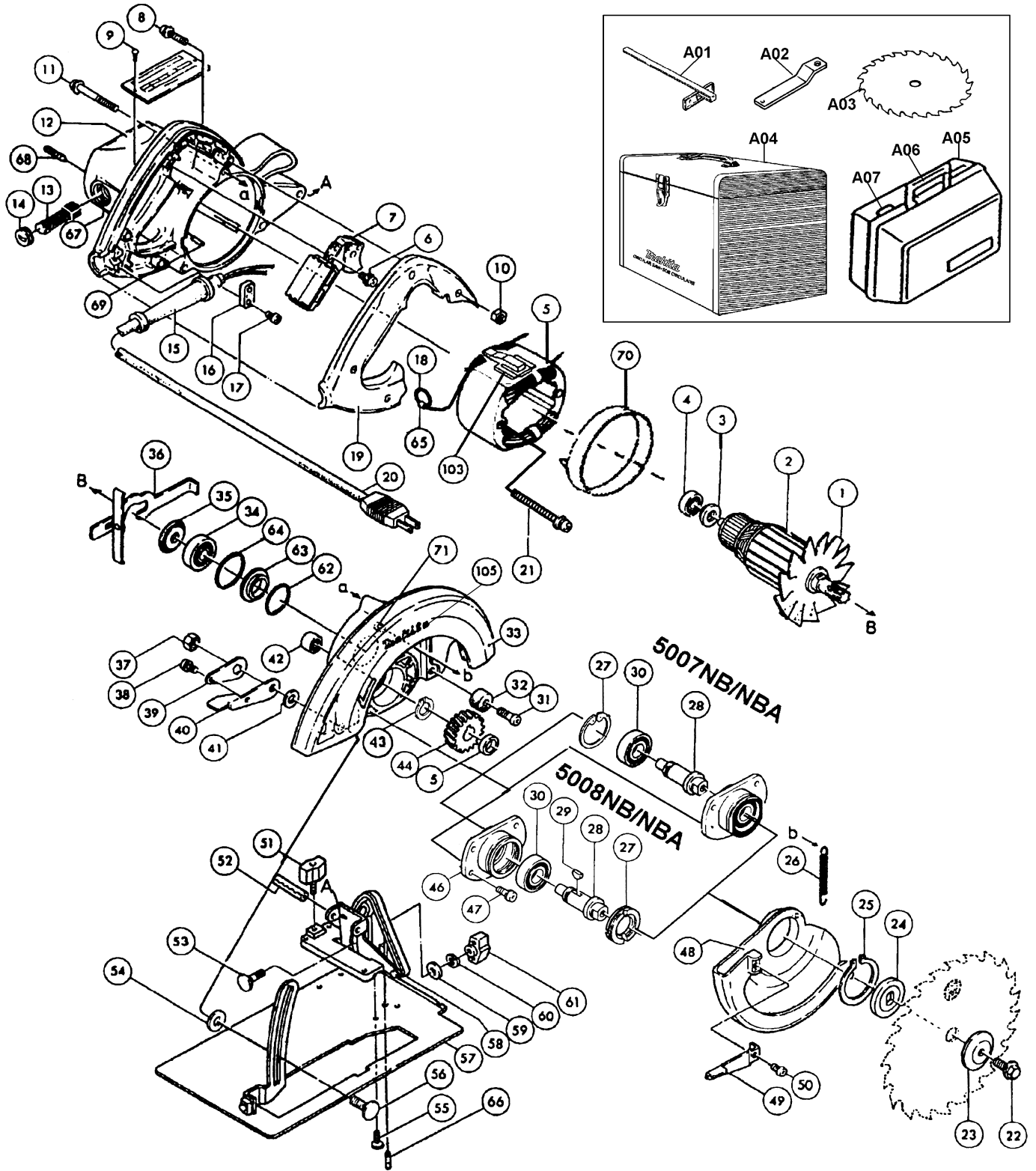

7 1/4" CIRCULAR SAW

8 1/4" CIRCULAR SAW

Model 5007NB (MCP)
 Model 5007NBA(MCP)
 Model 5007NBK (MCP)
 Model 5008NB(MCP)
 Model 5008NBA (MCP)



Item No.	Part No.	No. Used	Description	Item No.	Part No.	No. Used	Description
1	241513-4	1	Fan 92	31	251247-1	1	P.H. Screw M6x20
2	*	1	Armature Assy (Includes Items 1, 3, 4, 34 & 35)	32	262502-6	1	Rubber Sleeve 6
3	*	1	Insulation Washer (5007NB/5008NB)	33	*	1	Blade Case (5007NB)(Includes Items 42, 64, 71 & 105)
	681625-5	1	Insulation Washer (5007NBA/5008NBA)		*	1	Blade Case (Gold) (5007NBA)(Includes Items 42, 64, 71 & 105)
4	211033-2	1	Ball Bearing 608LB		153305-8	1	Blade Case (5008NB)(Includes Items 42 & 64) (Old 154322-1)
5	*	1	Field Assy (With Items 18 & 65) (5007NB/5008NB)		153305-8	1	Blade Case (5008NBA) (Includes Items 42, 64 & 71)(Old 154345-9)
	*	1	Field Assy (With Items 18 & 65) (5007NBA/5008NBA)	34	211106-1	1	Ball Bearing 6201LLB
6	911119-9	1	P.H. Screw M4x12 (With Washer)	35	213102-5	1	Dust Seal 12
7	651168-1	1	Switch (5007NB/5008NB)(Without Lock Button, AC/DC Type)(Type 2) (Use Item 100 Type 2 Screw)	36	163113-9	1	Spindle Lock (Shaft Lock)
	651121-7	1	Switch (Type 1) (5007NB/5008NB) (Without Lock Button, AC/DC Type)	37	931402-8	1	Hex Nut M8
	651042-3	1	Switch (5007NBA/5008NBA)	38	911106-8	1	P.H. Screw M4x8 (With Washer)
8	911148-2	4	P.H. Screw M4x25 (With Washer)	39	341415-5	1	Lock Plate
9	953106-2	2	Rivet 0-5 (Old)	40	341416-3	1	Lever Plate
10	931102-0	4	Hex Nut M4	41	941201-0	1	Flat Washer 8
11	911273-9	3	P.H. Screw M5x50 (With Washer)	42	212052-1	1	Needle Bearing 1010
12	*	1	Motor Housing (With Items 67 & 69)	43	961055-9	1	Retaining Ring S-15 *
13	181047-4	2	Carbon Brush CB-154 (5007NB/NBA/5008NB/NBA)	44	*	1	Helical Gear 39 (5007NB/5007NBA)
	181048-2	2	Auto Cut-Off Carbon Brush CB-155 (Optional)(5007NB/5008NB)(Optional) (5007NBA/5008NBA)		221687-7	1	Helical Gear 43 (5008NB/5008NBA)
14	643650-4	2	Brush Holder Cap	45	257064-7	1	Ring 15
15	682505-8	1	Cord Guard	46	*	1	Bearing Box (5007NB/5007NBA)
16	687001-1	1	Strain Relief		321362-6	1	Bearing Box (5008NB/5008NBA)
17	911131-9	2	P.H. Screw M4x18 (With Washer)	47	911126-2	4	P.H. Screw M4x16 (With Washer)
18	654020-2	2	Garter Spring	48	*	1	Safety Cover (5007NB/5007NBA)
19	*	1	Handle Cover (Includes Item 10)		315325-2	1	Safety Cover (5008NB/5008NBA)
20	664213-3	1	Cord With Plug 2P-16-2.5	49	341417-1	1	Lever
21	*	2	P.H. Screw M5x55 (With Washer & Bond)	50	911111-5	1	P.H. Screw M4x10 (With Washer) (5007NB/NBA - Type 1) (5008NB/5008NBA)
22	251644-1	1	Hex Flange Head Bolt M8x20		266026-4	1	Tapping Screw CT4X12 (5007NB/5007NBA - Type 2)
23	224275-9	1	Outer Flange 40	51	251858-2	1	P.H. Screw M6x15 (With Washer)
24	224151-7	1	Inner Flange 40	52	951225-8	1	Spring Pin 6-40
25	961201-4	1	Retaining Ring S-42	53	251920-3	1	Countersunk Head Bolt M6x30
26	231806-7	1	Tension Spring 4 (5007NB/5007NBA)	54	*	1	Flat Washer
	231753-2	1	Tension Spring 5 (5008NB/5008NBA)	55	912212-2	4	Countersunk Head Screw M5x12 (5007NB/5007NBA)
27	*	1	Bearing Retainer 22-36/Retaining Ring R-35(5007NB/5007NBA)		912212-2	4(5)	Countersunk Head Screw M5x12 (5008NB/5008NBA)
	285807-7	1	Bearing Retainer 22-36 (5008NB/5008NBA)	56	*	1	Countersunk Head Bolt M8x24
28	*	1	Spindle (Old 321060-2, 323789-6) (5007NB/5007NBA)	57	*	1	Base (5007NB)
	323789-6	1	Spindle (Old 321060-2) (5008NB/5008NBA)		163378-3	1	Base (5007NBA) (Old 163249-4)
29	254032-1	1	Woodruff Key 5 *		*	1	Base (5008NB)
30	211206-7	1	Ball Bearing 6202LLB		163250-9	1	Base (5008NBA)
				58	*	1	Angular Plate (5007NB)
					163248-6	1	Angular Plate (Gold) (5007NBA) (Old 163246-0)
					*	1	Angular Plate (5008NB)
					163253-3	1	Angular Plate (Gold) (5008NBA)

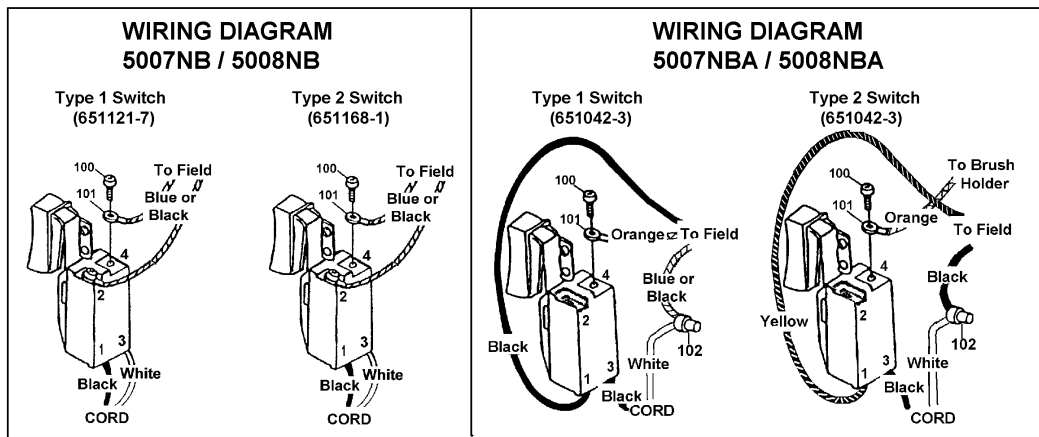

Item No.	Part No.	No. Used	Description	Item No.	Part No.	No. Used	Description
59	941151-9	1	Flat Washer 6				Switch - 651168-1)
60	942151-2	1	Spring Washer 6				
61	252624-0	1	Nut M6	101	654001-6	3-4	Solderless Eye Terminal 1.25-M3
62	213412-0	1	O Ring 29 (5008NB/5008NBA)	102	654510-5	1	Closed End Connector 5.5-SD (5007NBA/5008NBA)
63	341736-5	1	Washer 25 (5008NB/5008NBA)	103	687080-9	2	Field Clamp *
64	213459-4	1	O Ring 32	105	819003-1	1	Makita Logo Mark
65	654502-4	2	Solderless Connector P-2				
66	265882-9	1	(-) Screw M5x12 * (Type 1)				
	266180-4	1	(+) Screw M5x12 * (Type 2)				
	266213-5	1	H.S.H. Screw M5X12 * (Type 3)				
67	643660-1	2	Brush Holder (Old 643653-8)				Accessories
68	913206-0	2	Set Screw M5x8 (Old)	A01	164095-8	1	Guide Rule
69	263002-9	1	Rubber Pin 4	A02	782016-4	1	Closed End Wrench (Old 781203-2)
70	415603-1	1	Fan Guide (Added) *	A03	----	1	Saw Blade (See Catalogue for Details)
71	321062-8	1	Hook Pin	A04	823026-0X	1	Metal Carrying Case (Blue)
100	652021-4	3-4	Screw #5-40 UNCx5 (For Type 1 Switches 651121-7 & 651042-3)	A05	A00390-2	1	Plastic Carrying Case (Includes Items A06 & A07)
	652008-6	4	P.H. Screw M3.5X7 (For Type 2				

* SEE SERVICE CHANGES

SERVICE CHANGES

1. Change on Blade Case, Base and Angular Plate (5007NB only).

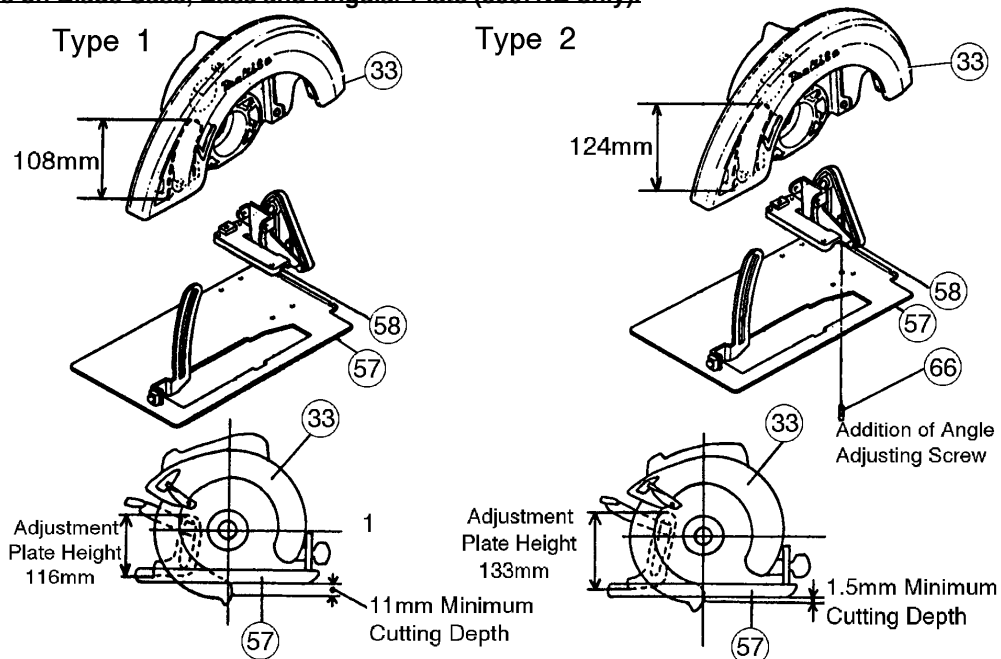

Item No.	Description	Type 1	Type 2	Type 3
33	Blade Case	154254-2 (No Longer Available)	153303-2 (154321-3)	See Service Change # 10
57	Base	163177-3 (No Longer Available)	163249-4	163378-3
58	Angular Plate	163178-1 (No Longer Available)	163248-6	
66	Screw M5x12	----	265882-9(-) / 266180-4 (+)	266213-5

Above parts are completely interchangeable as a set.
Type 2 Angular Plate can be used as Type 1 Angular Plate.

2. Change on Base and Angular Plate. (5008NB only).

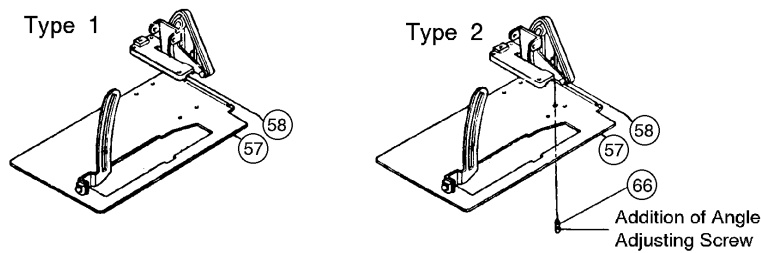

Item No.	Description	Type 1	Type 2	Type 3
57	Base	163218-5 (No Longer Available)	163250-9	
58	Angular Plate	163217-7 (No Longer Available)	163253-3	
66	Screw M5x12	----	265882-9(-) / 266180-4(+)	266213-5

Above parts are completely interchangeable as a set.
Type 2 Base and Angular Plate can be used as Type 1 Base and Angular Plate.

3. Change on Armature Shaft and Insulation Washer. (5007NB/5008NB only).

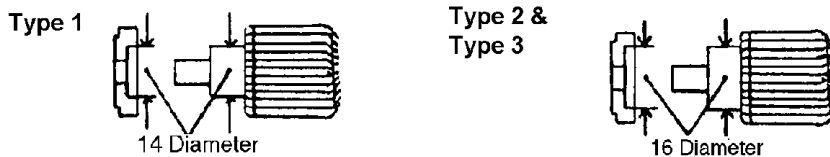

Item No.	Description	Type 1	Type 2	Type 3
2	Armature	614586-4		See Service Change #7
		Has 14mm shaft to accept Insulation Washer	Has 16mm shaft to accept Insulation Washer	
3	Insulation Washer	681613-2 (5007NB)	681625-5	
		681619-0 (5008NB) (No Longer Available)		

Type 2 Insulation Washer can be used with Type 1 Armature.

4. Change on Flat Washer & C.H. Bolt M8x24.

Item No.	Description	Type 1	Type 2	Type 3	
54	Flat Washer	253069-5 I.D. = ? 12mm	267096-6 I.D. =? 8mm	SEE SERVICE CHANGE # 10	
56	C.H. Bolt M8x24	251918-0	265965-5		
	Serial No.	5007NB	~ 307473		307474 ~
		5007NBA	~ 22300		22301 ~
		5007NBX	~ 311900		311901 ~
		5008NB	~ 57900		57901 ~
		5008NBA	~ 8100	8101 ~	

Above parts are completely interchangeable as a set.

5. Change on Motor Housing and Handle Cover.

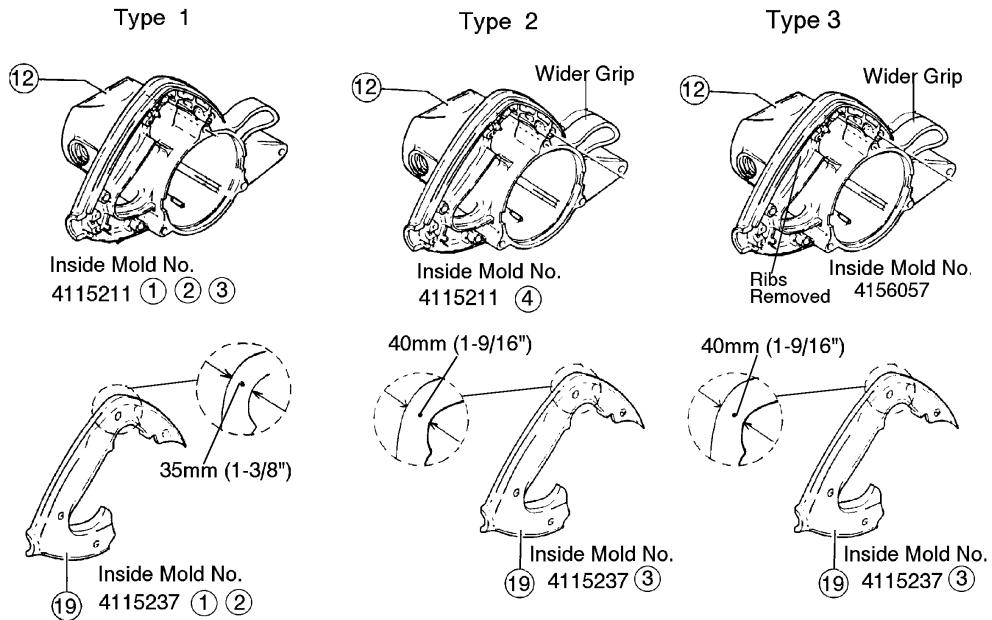

- 1) Type 2 Motor Housing and Handle Cover Switch area was widened.
- 2) Type 2 Motor Housing has pressed-in Brush Holder and no longer required the use of Set Screw. (Part No. 913206-0 x 2)
- 3) Type 3 Motor Housing and Handle Cover have a textured finished now.

Item No.	Description	Type 1	Type 2	Type 3
12	Motor Housing	156465-5 (No Longer Available)	156465-5A (No Longer Available)	156465-5B
19	Handle Cover	411523-7 (No Longer Available)	411523-7A (No Longer Available)	411523-7B
	Serial No.	5007NB	~ 326650	326651 ~
		5007NBA	~ 26800	26801~32815
		5008NB	~ 59900	59901 ~
		5008NBA	~ 9000	9001~9200

Above parts are completely interchangeable as a set. Type 2 & 3 Motor Hsg and Handle Cover are interchangeable,

6. Change on Bearing Box and Bearing Retainer. (5007NB/5007NBA)

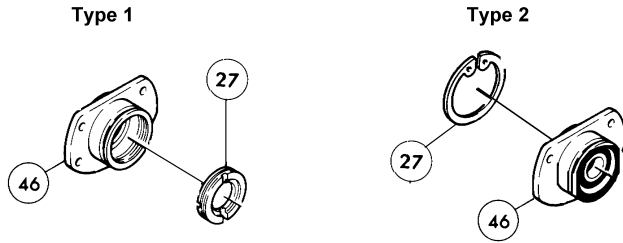

Item No.	Description	Type 1	Type 2
27	Bearing Retainer/Retaining Ring	285807-7	962153-2
46	Bearing Box	321061-0 (No Longer Available)	316700-5

7. Change on Armature, Field, Motor Housing etc.

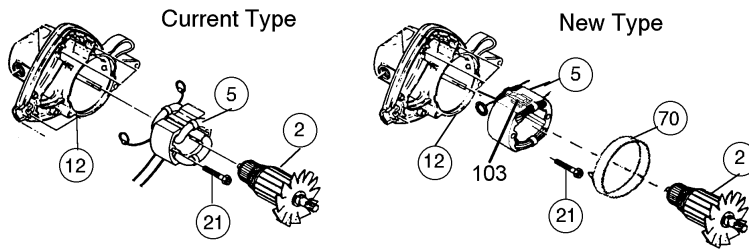

Item No.	Description	Current	New
2	Armature Assy	614586-4	616606-0
5	Field Assy 5007NB/5008NB	624536-1	636066-0
	Field Assy 5007NBA/5008NBA	524786-7	636071-7
12	Motor Housing	156465-5B	
21	P.H. Screw M5x55	911280-2	911676-7
70	Fan Guide	----	415603-1
103	Field Clamp	----	687080-9
	Serial No. 5007NB	~ 419037	419038 ~
	Serial No. 5007NBA	~ 66163	66164 ~
	Serial No. 5008NB	~ 70510	70511 ~
	Serial No. 5008NBA	~ 16108	16109 ~

8. Change on Safety Cover (5007NB/5007NBA ONLY)

Type 1

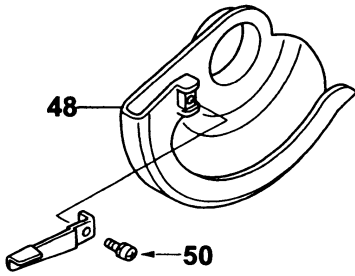

Type 2

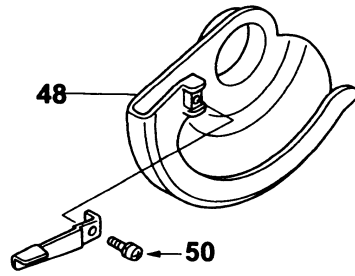

Item No.	Description	Type 1	Type 2	Type 3
48	Safety Cover	316244-5 (?4mm has threaded hole) (No Longer Available)	316962-5 (? 3mm has no thread)	See Service Change #10
50	Screw	911111-5 P.H. Screw M4X10	266026-4 Tapping CT4X12	
	Change in Products	Up to March 1999	After April 1999	

Above parts are completely interchangeable as a set.

9. Change on Gear, Spindle etc. (For 5007NB, 5007NBA, 5007NBK)

Type 1

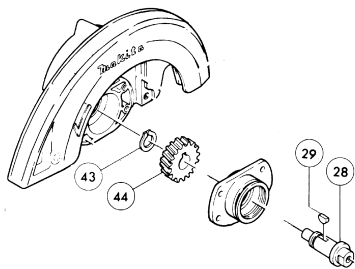

Type 2

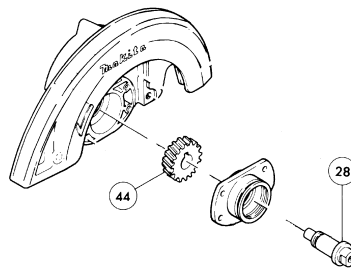

Type 3

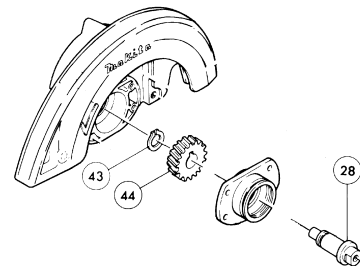

Item No.	Description	Type 1	Type 2	Type 3
28	Spindle	323789-6 (Old 321060-2)	324044-9 (No Longer Available)	324256-4
29	Woodruff Key 5	254032-1	-----	
43	Retaining Ring	961055-9	-----	961055-9
44	Helical Gear 39	221647-9	226532-1	

10. Change on Blade Case and Safety Cover. (5007NB/NBA)

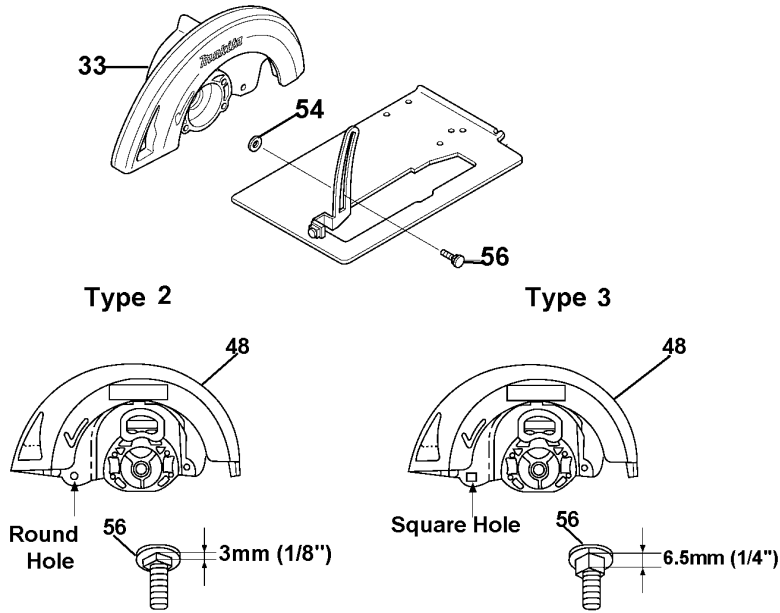

Item No.	Description	Type 2	Type 3
33	Blade Case Com.	153303-2(No Longer Available)	153531-9
48	Safety Cover	316962-5	317436-9
54	Flat Washer	267096-6 I.D. = 7.8mm	267113-2 I.D. = 7.12mm
56	C.H. Bolt M8X24	265965-5	266249-4
	Serial #		
		5007NB	307474 ~ 543155
		5007NBA	22301 ~ 104816
		5007NBK	~ 542543
		5007NBAK	~ 104245
			543156 ~
			107817 ~
			542544 ~
			104246 ~

Above parts are completely interchangeable as a set.
When replacing Blade Case Com. Change Item 54 & 56 at the same time.