

Makita

アメリカ

Impact Driver

MODEL 6950
Equipped with Electric Brake

INSTRUCTION MANUAL

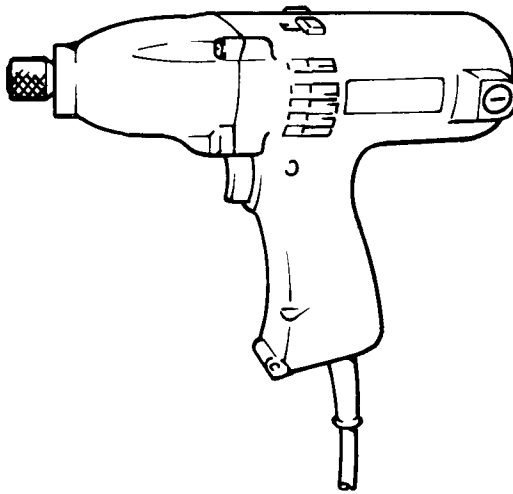

 **DOUBLE INSULATION**

SPECIFICATIONS

Capacities			No load speed (RPM)
Machine screw	Standard bolt	High tensile bolt	
4 mm – 8 mm (5/32" – 5/16")	6 mm – 12 mm (7/32" – 1/2")	6 mm – 12 mm (7/32" – 1/2")	0 – 2,200
Impacts per minute	Max. fastening torque	Dimensions (L x W x H)	Net weight
0 – 3,000	1,000 kg·cm (72.4 ft·lbs)	239 mm x 60 mm x 185 mm (9-3/8" x 2-3/8" x 7-1/4")	1.3 kg (2.8 lbs)

* Manufacturer reserves the right to change specifications without notice.

* Note: Specifications may differ from country to country.

WARNING: For your personal safety, READ and UNDERSTAND before using.

SAVE THESE INSTRUCTIONS FOR FUTURE REFERENCE.

IMPORTANT SAFETY INSTRUCTIONS

(For All Tools)

WARNING: WHEN USING ELECTRIC TOOLS, BASIC SAFETY PRECAUTIONS SHOULD ALWAYS BE FOLLOWED TO REDUCE THE RISK OF FIRE, ELECTRIC SHOCK, AND PERSONAL INJURY, INCLUDING THE FOLLOWING:

READ ALL INSTRUCTIONS.

- 1. KEEP WORK AREA CLEAN.** Cluttered areas and benches invite injuries.
- 2. CONSIDER WORK AREA ENVIRONMENT.** Don't use power tools in damp or wet locations. Keep work area well lit. Don't expose power tools to rain. Don't use tool in presence of flammable liquids or gases.
- 3. KEEP CHILDREN AWAY.** All visitors should be kept away from work area. Don't let visitors contact tool or extension cord.
- 4. STORE IDLE TOOLS.** When not in use, tools should be stored in dry, and high or locked-up place — out of reach of children.
- 5. DON'T FORCE TOOL.** It will do the job better and safer at the rate for which it was intended.
- 6. USE RIGHT TOOL.** Don't force small tool or attachment to do the job of a heavy-duty tool. Don't use tool for purpose not intended; for example, don't use circular saw for cutting tree limbs or logs.
- 7. DRESS PROPERLY.** Don't wear loose clothing or jewelry. They can be caught in moving parts. Rubber gloves and non-skid footwear are recommended when working outdoors. Wear protective hair covering to contain long hair.
- 8. USE SAFETY GLASSES.** Also use face or dust mask if cutting operation is dusty.
- 9. DON'T ABUSE CORD.** Never carry tool by cord or yank it to disconnect from receptacle. Keep cord from heat, oil, and sharp edges.
- 10. SECURE WORK.** Use clamps or a vise to hold work. It's safer than using your hand and it frees both hands to operate tool.
- 11. DON'T OVERREACH.** Keep proper footing and balance at all times.
- 12. MAINTAIN TOOLS WITH CARE.** Keep tools sharp and clean for better and safer performance. Follow instructions for lubricating and changing accessories. Inspect tool cords periodically and if damaged, have repaired by authorized service facility. Inspect extension cords periodically and replace if damaged. Keep handles dry, clean, and free from oil and grease.
- 13. DISCONNECT TOOLS.** When not in use, before servicing, and when changing accessories, such as blades, bits, cutters.

14. **REMOVE ADJUSTING KEYS AND WRENCHES.** Form habit of checking to see that keys and adjusting wrenches are removed from tool before turning it on.
15. **AVOID UNINTENTIONAL STARTING.** Don't carry tool with finger on switch. Be sure switch is OFF when plugging in.
16. **EXTENSION CORDS.** Make sure your extension cord is in good condition. When using an extension cord, be sure to use one heavy enough to carry the current your product will draw. An undersized cord will cause a drop in line voltage resulting in loss of power and overheating. Table 1 shows the correct size to use depending on cord length and nameplate ampere rating. If in doubt, use the next heavier gage. The smaller the gage number, the heavier the cord.

TABLE 1 MINIMUM GAGE FOR CORD SETS

			Total Length of Cord in Feet			
			0 – 25	26 – 50	51 – 100	101 – 150
Ampere Rating More Than	–	Not More Than	A W G			
0	–	6	18	16	16	14
6	–	10	18	16	14	12
10	–	12	16	16	14	12
12	–	16	14	12	Not Recommended	

17. **OUTDOOR USE EXTENSION CORDS.** When tool is used outdoors, use only extension cords intended for use outdoors and so marked.
18. **STAY ALERT.** Watch what you are doing, use common sense. Don't operate tool when you are tired.
19. **CHECK DAMAGED PARTS.** Before further use of the tool, a guard or other part that is damaged should be carefully checked to determine that it will operate properly and perform its intended function. Check for alignment of moving parts, binding of moving parts, breakage of parts, mounting, and any other conditions that may affect its operation. A guard or other part that is damaged should be properly repaired or replaced by an authorized service center unless otherwise indicated elsewhere in this instruction manual. Have defective switches replaced by authorized service center. Don't use tool if switch does not turn it on and off.
20. **GUARD AGAINST ELECTRIC SHOCK.** Prevent body contact with grounded surfaces. For example: pipes, radiators, ranges, refrigerator enclosures.
21. **REPLACEMENT PARTS.** When servicing, use only identical replacement parts.
22. **POLARIZED PLUGS.** To reduce the risk of electric shock, this equipment has a polarized plug (one blade is wider than the other). This plug will fit in a polarized outlet only one way. If the plug does not fit fully in the outlet, reverse the plug. If it still does not fit, contact a qualified electrician to install the proper outlet. Do not change the plug in any way.

VOLTAGE WARNING: Before connecting the tool to a power source (receptacle, outlet, etc.) be sure the voltage supplied is the same as that specified on the nameplate of the tool. A power source with voltage greater than that specified for the tool can result in **SERIOUS INJURY** to the user — as well as damage to the tool. If in doubt, **DO NOT PLUG IN THE TOOL**. Using a power source with voltage less than the nameplate rating is harmful to the motor.

ADDITIONAL SAFETY RULES

- 1. Wear ear protectors.**
- 2. Hold the tool firmly.**
- 3. Always be sure you have a firm footing.**
Be sure no one is below when using the tool in high locations.
- 4. When driving into walls, floors or wherever “live” electrical wires may be encountered, DO NOT TOUCH ANY METAL PARTS OF THE TOOL!**
Hold the tool only by the insulated grasping surfaces to prevent electric shock if you drive into a “live” wire.

SAVE THESE INSTRUCTIONS.

Installing or removing the bit

CAUTION:

Always be sure that the tool is switched off and unplugged before installing or removing the bit.

Use only the driver bit or socket bit shown at right. Do not use any other driver bit or socket bit.

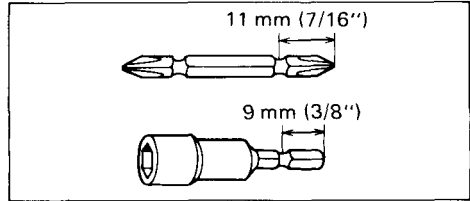

To install the bit, pull the sleeve in the direction of the arrow and insert the bit into the sleeve as far as it will go. Then release the sleeve to secure the bit.

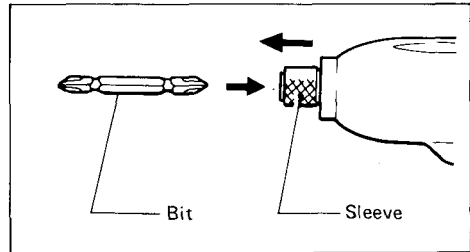

To remove the bit, pull the sleeve in the direction of the arrow and pull the bit out firmly.

NOTE:

If the bit is not inserted deep enough into the sleeve, the sleeve will not return to its original position and the bit will not be secured. In this case, try re-inserting the bit according to the instructions above.



Switch action

To start the tool, simply pull the trigger. Tool speed is increased by increasing pressure on the trigger. Release the trigger to stop.

CAUTION:

Before plugging in the tool, always check to see that the switch trigger actuates properly and returns to the "OFF" position when released.

Reversing switch action

This tool has a reversing switch to change the direction of rotation. Move the reversing switch to the  position for clockwise rotation or the  position for counterclockwise rotation.

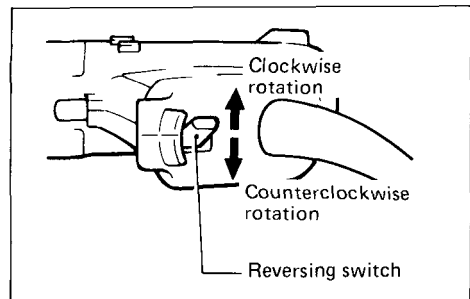

CAUTION:

- Always check the direction of rotation before operation.
- Use the reversing switch only after the tool comes to a complete stop. Changing the direction of rotation before the tool stops may damage the tool.

Operation

Place the point of the driver bit in the screw head. Apply forward pressure to the tool to the extent that the bit will not slip off the screw. Start the tool slowly and then increase the speed gradually. Release the trigger just as the screw bottoms out. The proper fastening torque differs depending upon the kind or size of screws/bolts, the type of materials to be fastened, etc. Refer to the figure below for the relation between fastening time and wood screw size.

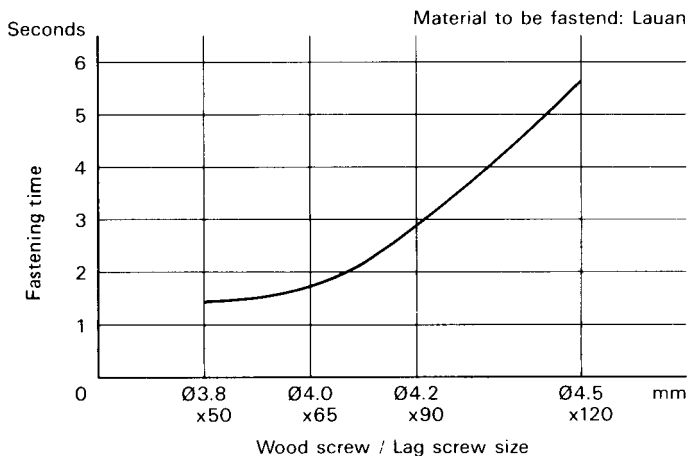

NOTE:

- Use the proper bit for the head of the screw/bolt that you wish to use.
- When fastening machine screws in a steel plate, the proper fastening torque can be obtained in an extremely short time (approx. 0.1 - 0.2 seconds). Turn the tool off as soon as the impact sound is heard.
- Hold the tool pointed straight at the screw or the screw and/or bit may be damaged.
- When driving wood screws, predrill pilot holes to make driving easier and to prevent splitting of the workpiece. The pilot holes should be slightly smaller than the wood screws in diameter.
- The size of wood screw which can be fastened with this tool may differ depending upon the type of material to be fastened. Always perform a test operation to determine the size of wood screw.
- When fastening bolts or nuts, always perform a test operation to verify the adequate fastening time for your bolt or nut. Excessive fastening torque may damage the bolt/nut or socket bit.

MAINTENANCE

CAUTION:

Always be sure that the tool is switched off and unplugged before attempting to perform inspection or maintenance.

Replacing carbon brushes

Remove and check the carbon brushes regularly. Replace when they wear down to the limit mark. Keep the carbon brushes clean and free to slip in the holders. Both carbon brushes should be replaced at the same time. Use only identical carbon brushes.

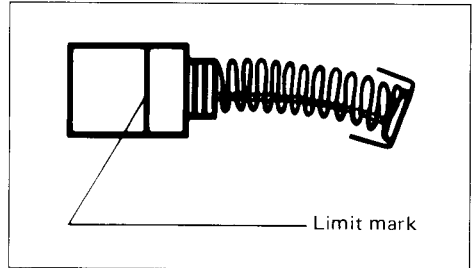

Use a screwdriver to remove the brush holder caps. Take out the worn carbon brushes, insert the new ones and secure the brush holder caps.

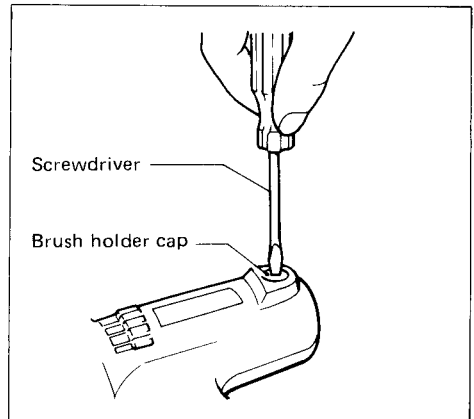

To maintain product SAFETY and RELIABILITY, repairs, any other maintenance or adjustment should be performed by Makita Authorized or Factory Service Centers, always using Makita replacement parts.

ACCESSORIES

CAUTION:

These accessories or attachments are recommended for use with your Makita tool specified in this manual. The use of any other accessories or attachments might present a risk of injury to persons. The accessories or attachments should be used only in the proper and intended manner.

• Bits

	Size	Part No.
Phillips	# 2	784214-0A
	# 3	784215-0A

IMPACT DRIVER

Model 6950

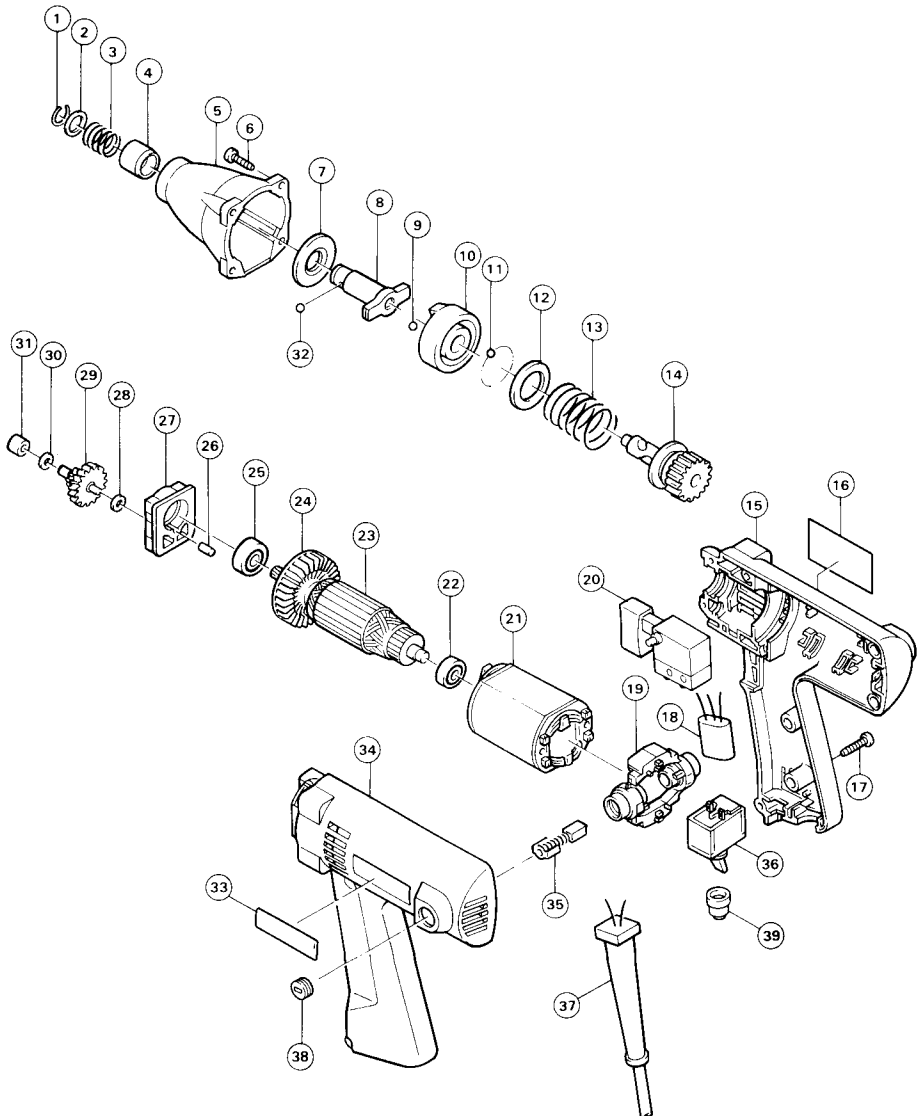

Note: The switch, noise suppressor and other part configurations may differ from country to country.

ITEM NO.	NO. USED	DESCRIPTION	ITEM NO.	NO. USED	DESCRIPTION
MACHINE			MACHINE		
1	1	Ring Spring 11	22	1	Ball Bearing 607LB
2	1	Flat Washer 12	23	1	ARMATURE ASSEMBLY
3	1	Compression Spring 13			(With Item 22, 24 & 25)
4	1	Sleeve	24	1	Fan 48
5	1	Hammer Case	25	1	Ball Bearing 608LLB
6	4	Tapping Screw BT4x20	26	1	Rubber Pin 4
7	1	Nylon Washer 14	27	1	Bearing Case (With Item 26)
8	1	Anvil	28	1	Flat Washer 4
9	2	Steel Ball 5.6	29	1	Gear Complete 9--34
10	1	Hammer	30	1	Flat Washer 5
11	24	Steel Ball 3.5	31	1	Plane Bearing 5
12	1	Flat Washer 22	32	2	Steel Ball 3.5
13	1	Compression Spring 24	33	1	Makita Label
14	1	Spindle Complete	34	1	Housing Set (With Item 15)
15	1	Housing Set (With Item 34)	35	2	Carbon Brush
16	1	Name Plate	36	1	Switch
17	9	Tapping Screw BT4x20	37	1	Cord
19	1	Holder Arm	38	2	Brush Holder Cap
20	1	Switch	39	1	Dust Cover
21	1	Field			

Note: The switch and other part specifications may differ from country to country.

MAKITA LIMITED ONE YEAR WARRANTY

Warranty Policy

Every Makita tool is thoroughly inspected and tested before leaving the factory. It is warranted to be free of defects from workmanship and materials for the period of ONE YEAR from the date of original purchase. Should any trouble develop during this one-year period, return the COMPLETE tool, freight prepaid, to one of Makita's Factory or Authorized Service Centers. If inspection shows the trouble is caused by defective workmanship or material, Makita will repair (or at our option, replace) without charge.

This Warranty does not apply where:

- repairs have been made or attempted by others;
- repairs are required because of normal wear and tear;
- The tool has been abused, misused or improperly maintained;
- alterations have been made to the tool.

IN NO EVENT SHALL MAKITA BE LIABLE FOR ANY INDIRECT, INCIDENTAL OR CONSEQUENTIAL DAMAGES FROM THE SALE OR USE OF THE PRODUCT. THIS DISCLAIMER APPLIES BOTH DURING AND AFTER THE TERM OF THIS WARRANTY.

MAKITA DISCLAIMS LIABILITY FOR ANY IMPLIED WARRANTIES, INCLUDING IMPLIED WARRANTIES OF "MERCHANTABILITY" AND "FITNESS FOR A SPECIFIC PURPOSE," AFTER THE ONE-YEAR TERM OF THIS WARRANTY.

This Warranty gives you specific legal rights, and you may also have other rights which vary from state to state. Some states do not allow the exclusion or limitation of incidental or consequential damages, so the above limitation or exclusion may not apply to you. Some states do not allow limitation on how long an implied warranty lasts, so the above limitation may not apply to you.

Makita Corporation

3-11-8, Sumiyoshi-cho,
Anjo, Aichi 446 Japan