

KOPPLA

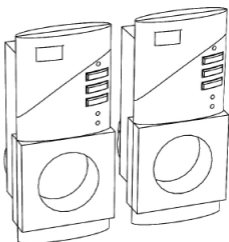

Design and Quality
IKEA of Sweden

CONTENTS

START HERE!	4
Insert the batteries in the remote control	4
Set the time and date	4
Program the receiver	7
DIRECT CONTROL	9
Choose channels	9
Functions	10
PROGRAMMING	12
Grouping	12
Choose group	13
Random on/off	13
Delay shut off	14
Timer programming	15
Programming example	18
Deactivate Timer program	21
Activate Timer program	21
OTHER FUNCTIONS	21
Key sound and background lighting on/off	21
Key lock on	22
Key lock off	22
Language selection	23
RECEIVER	24
Dimmer receiver (fig 2)	24
On/off receiver (fig 3)	25

TECHNICAL DATA	27
Remote control	27
Dimmer receiver	27
On/off receiver	27
REMEMBER	28
Installing the wall bracket for the remote control	29
LCD DISPLAY	30
Remote control (fig 7)	30
Dimmer receiver (fig 8)	30
On/off receiver (fig 9)	30
COMPONENT LAYOUT	32
Remote control (fig 1)	32
Dimmer receiver (fig 2)	32
On/off receiver (fig 3)	32

START HERE!

Insert the batteries in the remote control

1. Open the battery cover on the back.
2. Insert three AAA/LR03/AM4/ batteries
3. Close the battery cover.

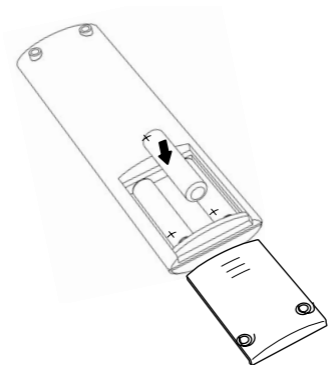

Set the time and date

1. Press **[FUNCTION]**

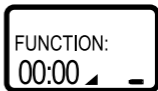

2. Press **[9]**



3. Select time format. You can choose between 12 and 24 hour display.

To change between 12 or 24 hour display, press **[UP]**



Press **[SET]** to continue.



- 3.1 24 hour display.

Enter the time, for example, 15.00. Press **[1],[5],[0],[0]**



- 3.2 12 hour display.

Enter the time, for example, 3.00 AM. Press **[0],[3],[0],[0], [DOWN]**



For 3.00 PM, press **[0],[3],[0],[0],[UP]**



4. State the day of the week. Press **[UP]** or **[DOWN]** to change the day of the week.



Sunday (SUN)
Monday (MON)
Tuesday (TUE)
Wednesday (WED)
Thursday (THU)
Friday (FRI)
Monday- Friday (M-F)
Saturday- Sunday (S-S)
Complete week (ALL)

5. Press **[SET]** to continue.

Program the receiver

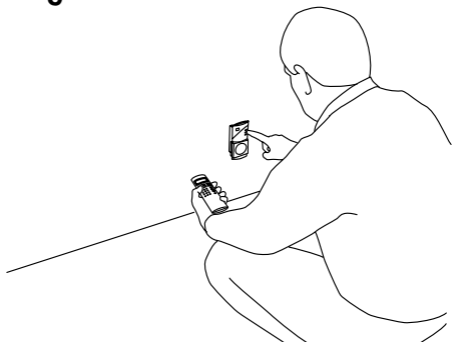

The receivers must be programmed to recognise signals from the remote control. Each receiver corresponds to a channel on the remote control. Up to 10 channels/receiver can be programmed.

1. Place the receiver in the wall socket.

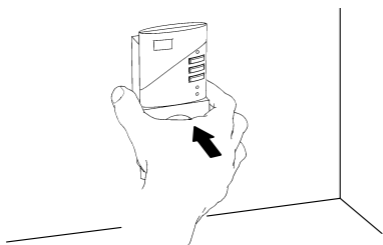

2. Press **[FUNCTION]** on the remote control.

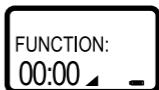

3. Press **[6]**

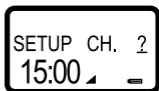

4. Select channel (1-10), for example, 1. Press **[1]**

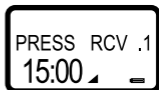

5. Press down one of the buttons on the receiver within 10 seconds. The red lamp on the receiver starts to flash to acknowledge the receiver has received the signal from the remote control.

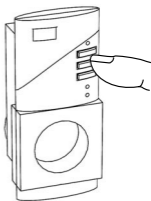

6. Press **[FUNCTION]** on the remote control.

If you have several receivers, repeat steps 1-6 choosing other channels. (Up to 10 channels)

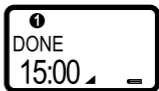

DIRECT CONTROL

Choose channels

1. To choose one or more channels (receiver) press **[CH]**

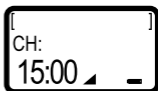

2. Choose, for example, receiver 2 by pressing **[2]**. The chosen channels are shown on the top row of the remote control display.

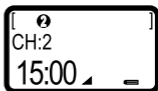

3. If you want to control several receivers at the same time, for example, receivers 1 and 2, press **[CH]** followed by **[1]** and **[2]**

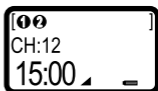

4. To clear the chosen channels press **[CH]** again.

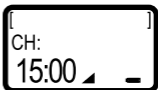

5. To choose all 10 channels press **[CH]** once again.

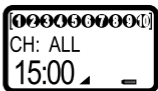

Functions

1. Switching on and off.

1.1 Choose the channel/s.

1.2 Press **[ON]** to switch on.

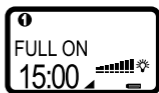

1.3 Press **[OFF]** to switch off.

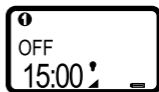

2. Dimmer. Increase or decrease the brightness. (Only applies to receivers with the dimmer function.)

NOTE: Energy saving bulbs do not work.

2.1 Choose the channel/s.

2.2 Press **[UP]** to increase the brightness.



2.3 Press **[DOWN]** to reduce the brightness.

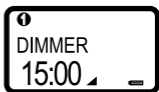

3 Set the brightness.

3.1 Choose the channel/s.

3.2 Press **[LEV]**

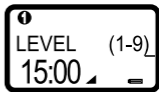

3.3 Choose brightness 1-9, for example 5. Press **[5]**

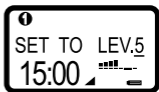

4. Gradual on/off or instant on/off.
- 4.1 Press **[FUNCTION]** followed by **[1]** to switch between gradual on/off and instant on/off.

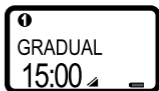

In gradual mode the lights are switched on and off with increasing respective decreasing brightness.



In instant mode the lights are switched on and off instantly.

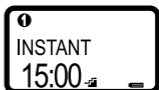

PROGRAMMING

Grouping

Instead of choosing channels one by one you can group and name different channels, e.g. living-room, bedroom, hall, etc.

1. Select group number, for example, 1, by pressing **[GRP]** followed by **[1]**

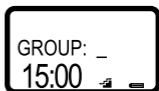

Scroll between the groups by pressing **[UP]** or **[DOWN]**

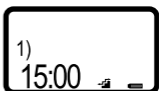

2. Press **[SET]** to state the group names. Use the number keys to enter letters and **[UP]** and **[DOWN]** to move the cursor. A maximum of 10 characters can be used.

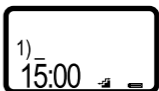

3. Press **[SET]** to confirm the name.

4. State which channels should belong to the group, for example channels 2, 3 and 8 by pressing the corresponding number keys.

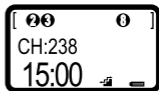
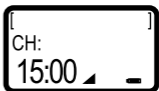

5. Press **[SET]** to save the group.

You can edit the groups by carrying out steps 1-5 to write over or change them.



Choose group

1. Select group number, for example, 1, by pressing **[GRP]** followed by **[1]**

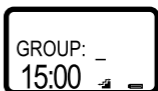

Scroll between the groups using **[UP]** or **[DOWN]**



Random on/off

This function switches chosen lights on and off at random time intervals.

1. Select the channel/s or group.
2. Press **[FUNCTION]** followed by **[3]**. The function is confirmed by the light being switched off if it was on or switched on if it was off. An R on the LCD display on the receiver indicates the function is active.

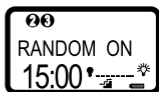

The function is deactivated by new commands to the chosen channels using the remote control, pressing keys on the receiver or if the receiver is removed from the wall socket.

Delay shut off

The function switches off the chosen lights after a predefined time. You set directly by channel/s or by group.

Channel/s:

1. Press **[CH]** followed by the number.

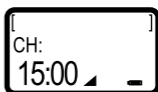

2. Press **[FUNCTION]** followed by **[2]**

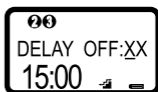

3. State the length of the delay you would like, for example after 15 minutes.

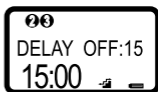

The time can be stated between 1-99 minutes.
NOTE! Pressing the key again deactivates the function.

Group:

1. Press **[GRP]** followed by the number.

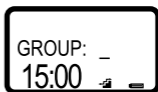

2. Press **[FUNCTION]** twice followed by **[2]**

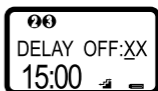

3. State the length of the delay you would like, for example after 15 minutes.

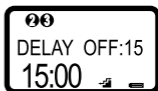

The time can be stated between 1-99 minutes.
NOTE! Pressing the key again deactivates the function.

Timer programming

1. Press **[PROG]**



2. Select the program number (01-16). Press **[0],[1]** for program 1.

The display shows EMPTY if the chosen program has not previously been programmed. If it has been preprogrammed the program settings are shown.



3. Press **[SET]** to continue.

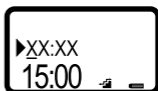

4. State the time when you would like the command to be executed, for example, 6 PM.

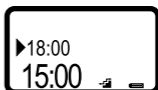

To state AM/PM press **[UP]** or **[DOWN]**

5. Select the day by pressing **[UP]** or **[DOWN]**

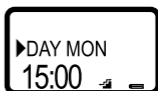

Sunday (SUN)

Monday (MON)

Tuesday (TUE)

Wednesday (WED)

Thursday (THU)

Friday (FRI)

Monday- Friday (M-F)

Saturday- Sunday (S-S)

Complete week (ALL)

6. Press **[SET]** to continue.

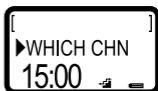

7. Choose the channel/s. For example, press **[2]** for channel 2.

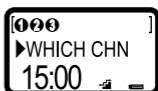

8. Press **[SET]** to continue.

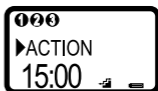

9. Select the command

On = Press **[ON]**

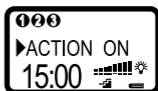

Random on/off = Press **[ON]** once again.

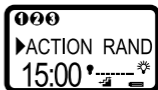

Off = press **[OFF]**

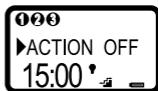

Preset brightness =
Press **[LEV]** followed by
a number for the level
(1-9).

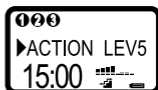

10. Press **[SET]** to save the
program.

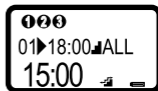

11. You can scroll between the programs
by pressing **[UP]** or **[DOWN]**

Programming example

The example shows the following: Switch on (instant) a light connected to receiver/channel 1 at 18.00 on Saturdays and Sun-days. Switch off the same light at clock 23.00 on Saturdays and Sundays. Each ACTION requires a program, i.e. this example will need two programs saved as PROG 01 and PROG 02.

Switch on:

[PROG]



[0],[1]



[SET]



[1],[8],[0],[0]

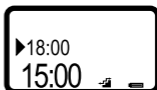

[DOWN] X times

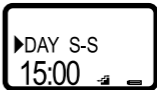

[SET]

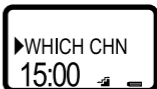

[1]

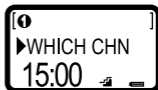

[SET]

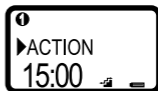

[ON]

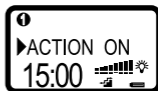

[SET]



Switch off:

[PROG]



[0],[2]



[SET]



[2],[3],[0],[0]

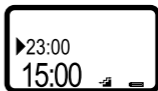

[DOWN] X times

▶DAY S-S

15:00



[SET]

▶WHICH CHN

15:00



[1]

[i]

▶WHICH CHN

15:00



[SET]

[i]

▶ACTION

15:00



[OFF]

[i]

▶ACTION OFF

15:00



[SET]

[i]

01▶18:00 S-S

15:00



Deactivate Timer program

1. Choose the program.
Press **[PROG]** followed by the program number.



2. Press **[OFF]**



Activate Timer program

1. Choose the program.
Press **[PROG]** followed by the program number.
2. Press **[ON]**

OTHER FUNCTIONS

Key sound and background lighting on/off

1. Press **[FUNCTION]** followed by **[5]**
2. Scroll with **[ON]** or **[OFF]** to adjust the key sound.

ON= Key sound on confirmation.



OFF= Key sound switched off.

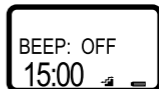

CLICK= Key sound with key use.

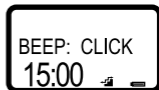

3. Press **[SET]** to adjust background lighting.
4. Scroll with **[ON]** or **[OFF]** to switch the background lighting on or off.
5. Press **[SET]**



Key lock

1. To use the key lock function, enter a 3-digit code by first pressing **[FUNCTION]** followed by **[7]**
2. Enter a 3-digit code.
3. Press **[FUNCTION]** twice.

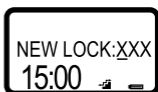

Key lock on

1. Press and hold down **[FUNCTION]** for 3 seconds.

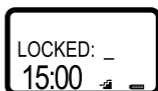

Key lock off

1. Enter your 3-digit code. If you forget your code you can deactivate the key lock by taking out and reinserting the batteries.



Language selection

1. The transmitter offers three language options to choose between.

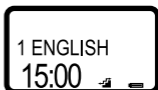

- Press **[FUNCTION]** followed by **[0]**
2. Press **[UP]** or **[DOWN]** to choose a language.
3. Press **[SET]**

Changing the system code with interference

The transmitter automatically sets a system code when you insert the batteries. If your neighbour also owns a KOPPLA remote control and by chance has the same system code you may experience operating disturbances. You can manually set a system code (01-16). Do this:

1. Press **[FUNCTION]** followed by **[8]**
2. State two digits for the system code, e.g. 03
3. Press **[FUNCTION]**

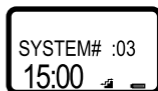

All receivers must be reprogrammed if a new system code is chosen, page 7.

RECEIVER

Dimmer receiver (fig 2)

The receiver is only intended for lighting.

Installation:

1. Insert the receiver in the outlet socket. The Main lamp, green lamp, comes on when the receiver is connected to the mains supply.
2. Connect the lamp/lamps (max combined output 300W) to the receiver.

Manual on/off:

1. Press **[ON/OFF]** to switch the lamp on or off. The output lamp, the red, comes on when the receiver powers the connected lamp.

Manual brightness:

1. Press **[UP]** to increase the brightness. Press **[DOWN]** to reduce the brightness. The receiver "will remember" the set brightness, for example, if you switch off the lamp at a set brightness level, it will switch on the lamp at the same level of brightness.

Deactivate reception:

1. If you do not want the receiver to receive signals from the remote control, press and hold down the **[ON/OFF]** key on the receiver, for 3 seconds.

The -symbol is shown on the receiver's LCD display. Press **[ON/OFF]** on the receiver for 3 seconds to allow the reception of signals again.



Resetting:

If commands are not shown on the receiver's LCD display, strange characters are displayed or it does not react when keys are pressed the receiver needs to be reset.

1. Press in "the small" **[R]** key on the receiver. The receiver shuts off and resets random on/off, deactivate remote control and the set brightness.

On/off receiver (fig 3)

Installation

1. Insert the receiver in the outlet socket. The Main lamp, green lamp, comes on when the receiver is connected to the mains supply.
2. Connect a device (max 3680W) to the receiver.

Manual on/off:

1. Press **[ON/OFF]** to switch the lamp on or off. The output lamp, red, comes on



when the receiver powers a connected lamp.

Deactivate reception:

1. If do not want the receiver to receive signals from the remote control, press and hold down the **[ON/OFF]** for 3 seconds. The -symbol is shown on the receiver's LCD display. Press **[ON/OFF]** for 3 seconds to allow the receiver to receive signals from the remote control.

Resetting:

If commands are not shown on the receiver's LCD display, strange characters are displayed or it does not react when keys are pressed the receiver needs to be reset.

1. Press in "the small" **[R]** key. The receiver shuts off and resets random on/off, deactivate remote-control and the set brightness.

TECHNICAL DATA

Remote control

Range: 25 m clear view. Walls and other objects limit the range.

Batteries: Three AAA/LR03/AM4/Micro.

Frequency: 433MHz.

Dimmer receiver

Mains voltage: 120VAC, 60Hz

Load: 20- 200W

Fuse: 1.6A

NOTE: Only incandescent lamps (120V), halogen lamps (120V) and halogen lamps with a transformer (120V) may be connected to the dimmer receiver.

On/off receiver

Mains voltage: 120VAC, 60Hz

Max load: 1800W

REMEMBER

never overload the receiver.

never interconnect the receivers.

that the receivers are for indoor use

(0°-35°C) and must not be used outdoors.

never open the receiver or remote control.

never expose the receiver or remote control to strong cleaning agents and moisture.

never poke objects in the outlet sockets.

to only clean the remote control with a damp cloth.

to replace the batteries in the remote control when the battery indicator shows they are empty and the display is unclear.

if you have programmed the timer in the remote control, that it must be within range as it is the remote control that controls the receiver.

Installing the wall bracket for the remote control

1

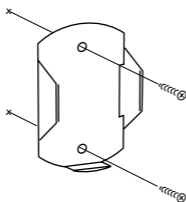

2

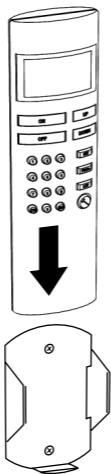

LCD DISPLAY

Remote control (fig 7)

1. Channels
2. Text
3. Off symbol
4. Clock
5. Gradual on/off symbol
6. Instant on/off symbol
7. Signal symbol
8. Battery capacity symbol
9. On symbol
10. Brightness

Dimmer receiver (fig 8)

1. On symbol
2. Brightness
3. Random on/off
4. Reception symbol
5. Channel number

On/off receiver (fig 9)

1. On symbol
2. Random on/off
3. Reception symbol
4. Channel number

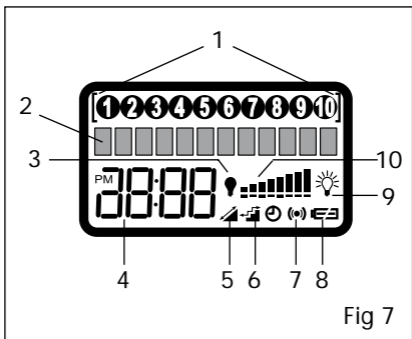

Fig 7

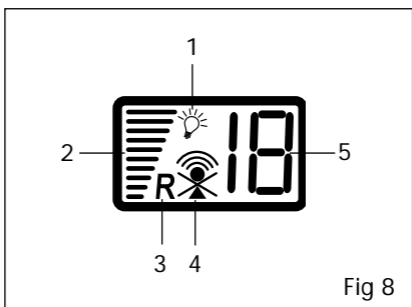

Fig 8

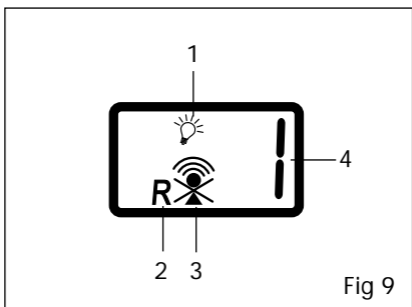

Fig 9

COMPONENT LAYOUT

Remote control (fig 1)

1. LCD display
2. (ON)
3. (OFF)
4. Number/letter keys
5. Channel (CH)
6. Group (GRP)
7. Brighter/Menu selection (UP)
8. Darker/Menu selection (DOWN)
9. (SET)
10. Programming (PROG)
11. Brightness level (LEV)
12. Function

Dimmer receiver (fig 2)

1. LCD display
2. (RESET)
3. Brighter (UP)
4. On/Off

On/off receiver (fig 3)

1. LCD display.
2. (RESET)
3. (ON/OFF)
4. Mains connection (MAIN)
5. (OUTPUT)

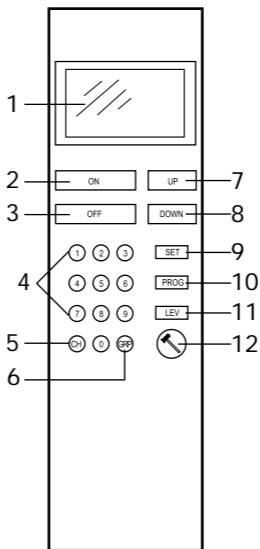
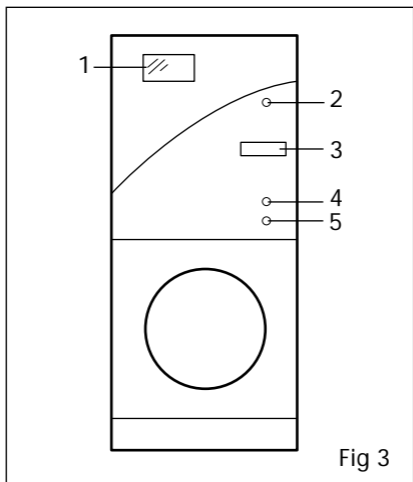
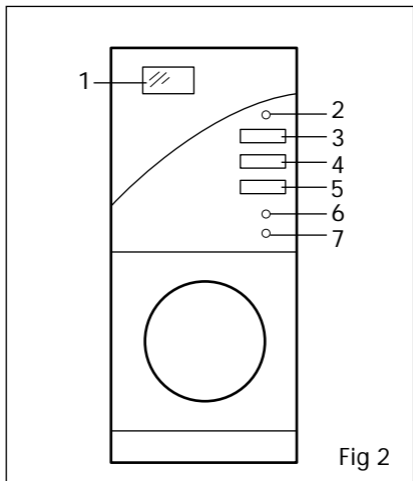

Fig 1



This equipment has been tested and found to comply with the limits for a Class B digital device, pursuant to Part 15 of the FCC Rules. These limits are designed to provide reasonable protection against harmful interference in a residential installation. This equipment generates, uses and can radiate radio frequency energy and, if not installed and used in accordance with the instructions, may cause harmful interference to radio communications. However, there is no guarantee that interference will not occur in a particular installation. If this equipment does cause harmful interference to radio or television reception, which can be determined by turning the equipment off and on, the user is encouraged to try to correct the interference by one or more of the following measures:

- Reorient or relocate the receiving antenna.
- Increase the separation between the equipment and receiver.
- Connect the equipment into an outlet on a circuit different from that to which the receiver is connected.
- Consult the dealer or an experienced radio/TV technician for help.

Warning: Changes or modifications made to this equipment not expressly approved may void the FCC authorization to operate this equipment.