

ADVANCE

OPERATOR
M A N U A L

Retriever™ 134B
Model 467215

TABLE OF CONTENTS

	Page
Introduction	2
Parts and Service	2
Nameplate	2
Uncrating the Machine	2
Important Safety Instructions	3
Consignes de sécurité	4
Know Your Machine	5
Preparing the Machine for Use	6-7
Battery Installation	6
To Install the Side Broom	7
Operating the Machine	8
After Using the Machine	9
Batteries	9
Maintenance	10-11
Dust Control Filter	10
Lubrication	10
Broom Maintenance	11
To Adjust the Main Broom	11
To Replace the Main Broom	11
Troubleshooting	12
Technical Specifications	13

INTRODUCTION

This manual will help you get the most from your **Advance Retriever™ 134B**. Read it thoroughly before operating the machine.

Note: Bold numbers in parentheses indicate an item illustrated on page 5.

This product is intended for commercial use only.

PARTS AND SERVICE

Repairs, when required, should be performed by your Authorized Advance Service Center, who employs factory trained service personnel, and maintains an inventory of Advance original replacement parts and accessories.

Call the ADVANCE DEALER named below for repair parts or service. Please specify the Model and Serial number when discussing your machine.

(Dealer, affix service sticker here.)

NAME PLATE

The Model and Serial Number of your machine are shown on the Nameplate on the rear of the machine. This information is needed when ordering repair parts for the machine. Use the space below to note the Model and Serial Number of your machine for future reference.

MODEL _____

SERIAL NUMBER _____

UNCRATING THE MACHINE

When the machine is delivered, carefully inspect the shipping carton and the machine for damage. If damage is evident, save the shipping carton so that it can be inspected. Contact the Advance Customer Service Department immediately to file a freight damage claim.

After removing the carton, cut the plastic strapping and remove the wooden blocks next to the wheels. Use a ramp to roll the machine from the pallet to the floor.

IMPORTANT SAFETY INSTRUCTIONS

SYMBOLS

Advance uses the symbols below to signal potentially dangerous conditions. Read this information carefully and take the necessary steps to protect personnel and property.

DANGER !

Is used to warn of immediate hazards that will cause severe personal injury or death.

WARNING !

Is used to call attention to a situation that could cause severe personal injury.

CAUTION !

Is used to call attention to a situation that could cause minor personal injury or damage to the machine or other property.

GENERAL SAFETY INSTRUCTIONS

Specific Cautions and Warnings are included to warn you of potential danger of machine damage or bodily harm.

WARNING !

- * This walk-behind sweeper is not suitable for sweeping toxic substances. It is a U class machine.
- * The walk-behind sweeper must only be used by trained and authorized personnel.
- * Always switch the walk-behind sweeper OFF before performing any cleaning, maintenance, or part replacement operations.
- * Always park the walk-behind sweeper on a flat, level surface so the machine will not roll away.
- * Keep all bystanders, and particularly children, well clear of the walk-behind sweeper when in use.
- * Only charge the battery in a well ventilated area.
- * Remove the key when you finish work to avoid unauthorized use of the walk-behind sweeper.
- * Make sure that the motor is stopped before opening the electric motor compartment.
- * When transporting the walk-behind sweeper, make sure that it is securely anchored to the vehicle.
- * Always dispose of the debris according to all Designated Disposal Laws.

IMPORTANT !

Read these operating and maintenance instructions carefully before starting the walk-behind sweeper. Perform the operations listed in the scheduled maintenance table punctually to maintain the walk-behind sweeper at peak efficiency and to ensure a long working life.

SAVE THESE INSTRUCTIONS

CONSIGNES DE SÉCURITÉ

SYMBOLES

Les symboles ci-dessous sont utilisés pour signaler des conditions d'emploi qui présentent un danger. Lisez ces informations avec soin et prenez les mesures nécessaires de protection des personnes et des biens.

DANGER !

avertit de dangers immédiats causant des blessures graves ou la mort.

ATTENTION !

attire l'attention sur une situation pouvant causer des blessures graves aux personnes.

PRÉCAUTIONS D'EMPLOI !

attire l'attention sur une situation pouvant causer des blessures légères ou des dommages à la machine ou à d'autres biens.

CONSIGNES GÉNÉRALES DE SÉCURITÉ

Précautions d'emploi et recommandations spécifiques, vous avertissent des dangers possibles d'endommagement de la machine ou de dommages corporels.

ATTENTION !

- * Cette machine ne convient pas à aspirer de substances toxiques et doit donc être classée dans la catégorie U.
- * La balayeuse ne doit être utilisée que par du personnel formé et autorisé.
- * Veiller à ce que l'interrupteur (marche/arrêt) soit sur arrêt, avant de procéder à toute opération de nettoyage, entretien et remplacement de pièces.
- * Lors du stationnement, veiller à ce que la machine soit stable.
- * A chaque fois que la machine est en service, s'assurer que personne n'est à proximité de la machine, notamment les enfants.
- * La recharge de la batterie doit absolument se faire dans un endroit couvert.
- * Enlever la clé pour éviter toute utilisation abusive.
- * Le coffre ne doit s'ouvrir qu'au cas où le moteur électrique ne fonctionnerait pas; veiller donc à ne pas altérer le microinterrupteur de sûreté.
- * La balayeuse doit être fixée au véhicule pendant le transport.
- * L'écoulement des déchets ramassés doit se faire en conformité avec les lois nationales en vigueur en matière.

IMPORTANT !

Nous vous conseillons de lire attentivement le mode d'emploi et d'entretien, avant la mise en service de la machine. Respecter scrupuleusement la cadence des opérations à effectuer figurant au tableau pour assurer l'efficacité et la longévité maximales de la machine. Nous désirons vous remercier de votre préférence pour notre produit et restons à la disposition pour tout autre renseignement.

CONSERVER CES INSTRUCTIONS

KNOW YOUR MACHINE

As you read this manual, you will occasionally run across a bold number in parentheses - example: (2). These numbers refer to an item on this page. Refer back to this page whenever necessary to pinpoint the location of an item mentioned in the text.

- 1 Control Handle Twist Grips
- 2 Shaker Motor Switch
- 3 Battery Gauge
- 4 Brush Switch
- 5 Parking Brake Lever
- 6 Kick back Stand
- 7 Static Arrestor
- 8 Main Broom Height Adjustment Lever
- 9 Master Switch ON/OFF
- 10 Machine Battery Charger Plug
- 11 Broom Motor Circuit Breaker
- 12 Drive Motor Circuit Breaker
- 13 Control Circuit Circuit Breaker
- 14 Battery Compartment
- 15 Shaker Motor / Dust Filter Access Door
- 16 Hopper
- 17 Side Broom

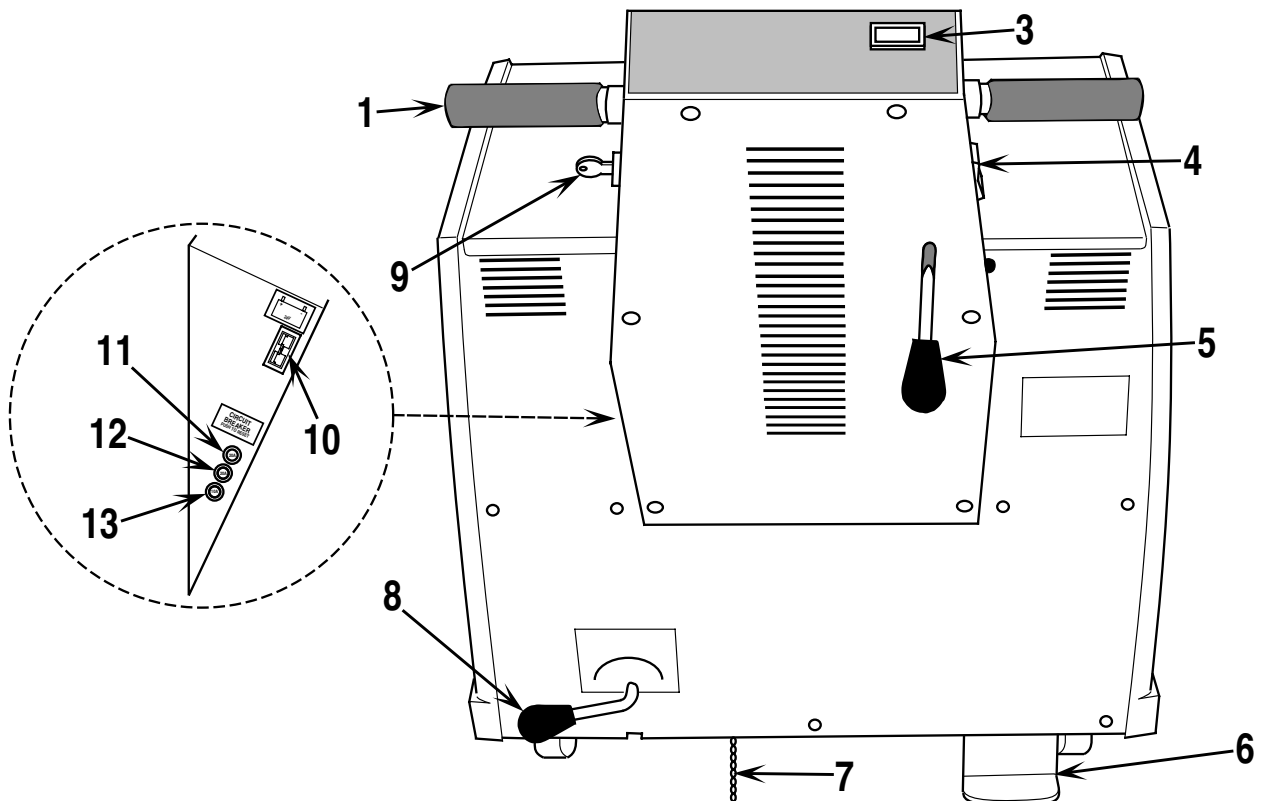
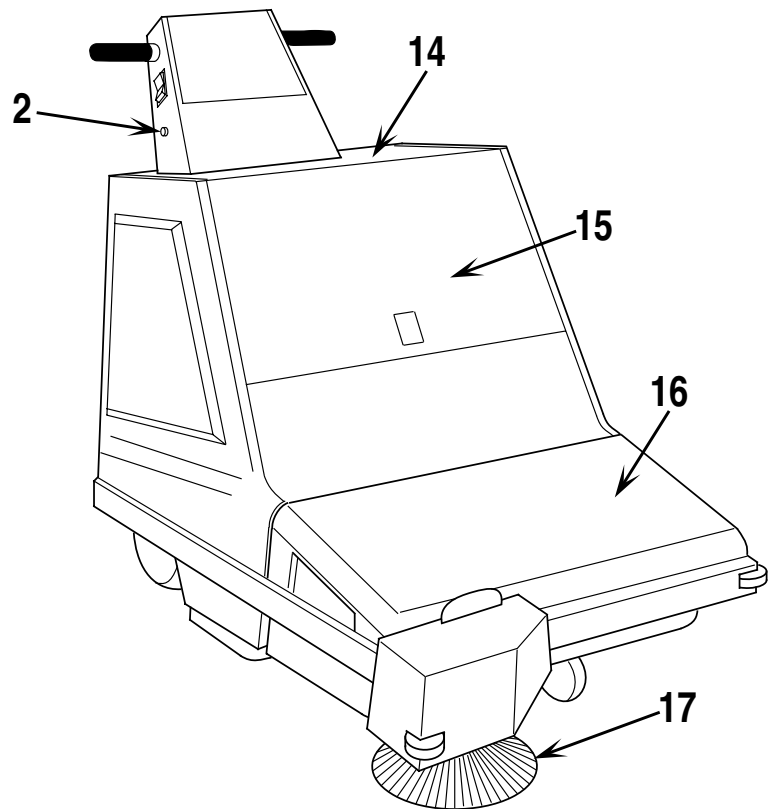

PREPARING THE MACHINE FOR USE

BATTERY INSTALLATION

⚠ WARNING !

Use extreme caution when working with batteries. Sulfuric acid in batteries can cause severe injury if allowed to contact the skin or eyes. Explosive hydrogen gas is vented from inside the batteries through openings in the battery caps. This gas can be ignited by any electric arc, spark or flame.

⚠ WARNING !

When servicing batteries...

- * Remove all jewelry
- * Do not smoke
- * Wear safety glasses
- * Work in a well ventilated area
- * Do not allow tools to touch more than one battery terminal at a time

⚠ CAUTION !

Electrical components in this machine can be severely damaged if the batteries are not installed and connected properly. Batteries should be installed by your local Advance Dealer or by a Qualified Electrician.

- 1 Remove the batteries from their shipping crate and carefully inspect them for cracks or other damage. If damage is evident, contact the trucking company that delivered them or the battery manufacturer to file a damage claim.
- 2 Open the hood and remove the battery cables from inside. Make sure that the Master Switch is in the OFF position.
- 3 Carefully lift the batteries into the battery compartment and arrange them exactly as shown in Figure 1.
- 4 The terminals on the battery cables are marked (+) for positive and (-) for negative. Install the battery cables as shown in Figure 1, with the terminals marked (+) on the positive battery terminals and the terminals marked (-) on the negative battery terminals. Position the cables so that all battery caps can be easily removed for battery service.
- 5 Carefully tighten the nut on each battery terminal until the terminal will not turn on the battery posts. Then tighten the nut one more full turn. Do not over tighten the terminals, or they will be very difficult to remove for future service.
- 6 Coat all of the terminals and posts with grease, petroleum jelly or spray-on battery terminal coating (available at most auto parts stores).
- 7 Put one of the black rubber "boots" over each of the terminals and use the plastic tie straps to hold them in place.

FIGURE 1

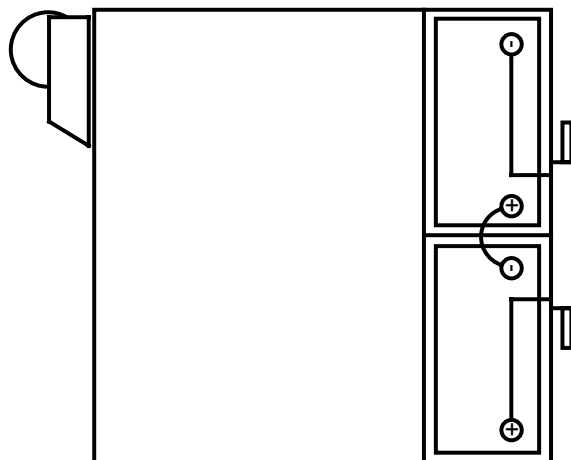

PREPARING THE MACHINE FOR USE

TO INSTALL THE SIDE BROOM

- 1 Push the spring plate on the side broom assembly and slide onto side broom mounting plate located at the front right corner of the machine.
- 2 Plug the electrical cable of the side broom into the outlet on the machine frame.

FIGURE 2

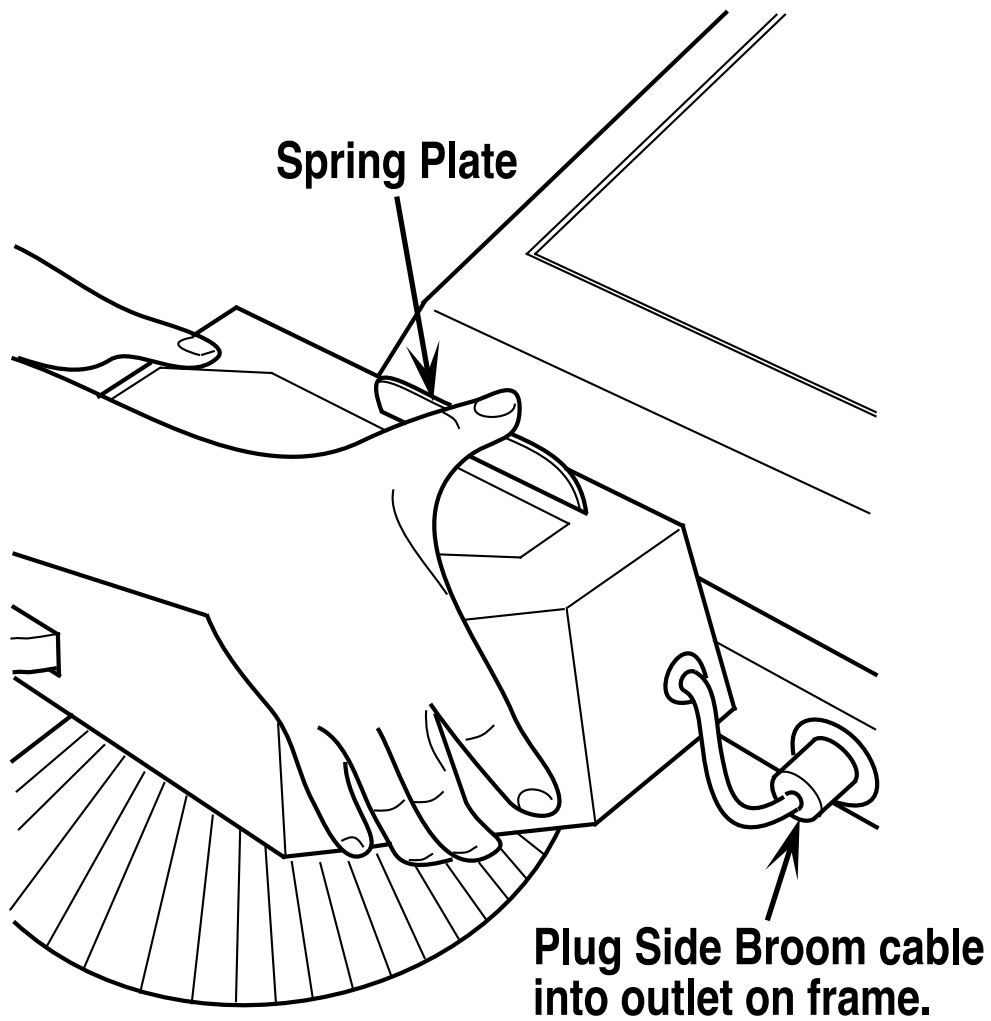

OPERATING THE MACHINE

With the machine prepared as covered in the previous section, you are ready to operate the Retriever 134B.

- 1 Turn the Master Switch (9) ON.
- 2 Set the Main Broom Lever (8) to the number 1 position.
- 3 Turn the main broom on by switching Brush Switch (4) to the up position.
- 4 Lower the Side Broom (17) (if so equipped) so that the front right third of the brush is touching the floor as shown in Figure 3. Plug Side Broom electrical cord into outlet at front of machine.

FIGURE 3

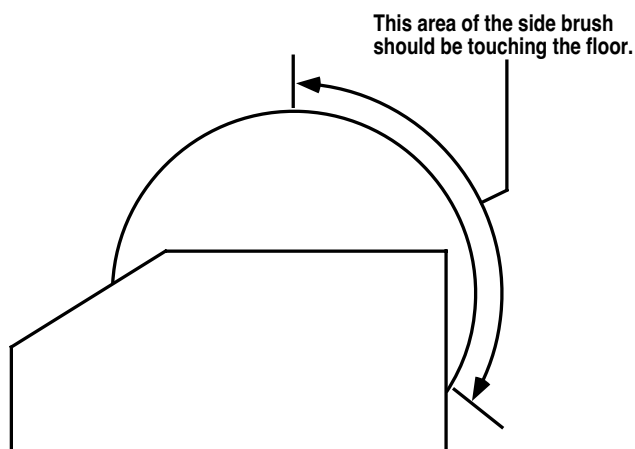

- 5 Turn on the side and main broom by pushing Brush Switch (4) to the down position. Do all edge sweeping using the side broom, then raise the side broom and finish sweeping with only the main broom. This procedure will minimize airborne dust generated by the side broom.
- 6 Rotate the Control Handle Twist Grips (1) forward to propel forward, backward to propel in reverse.
- 7 Check hopper periodically and empty when needed. To empty hopper, turn Master Switch (9) and Brush Switch (4) OFF. Lift Hopper (16) out of machine as shown in Figure 4.
- 8 When sweeping extremely dusty floors, it will be necessary to stop sweeping and push the Shaker Motor Switch (2). Hold the button in for about 10-15 seconds to operate the filter shaker, repeat 5 times in succession to clean the filter thoroughly.

FIGURE 4

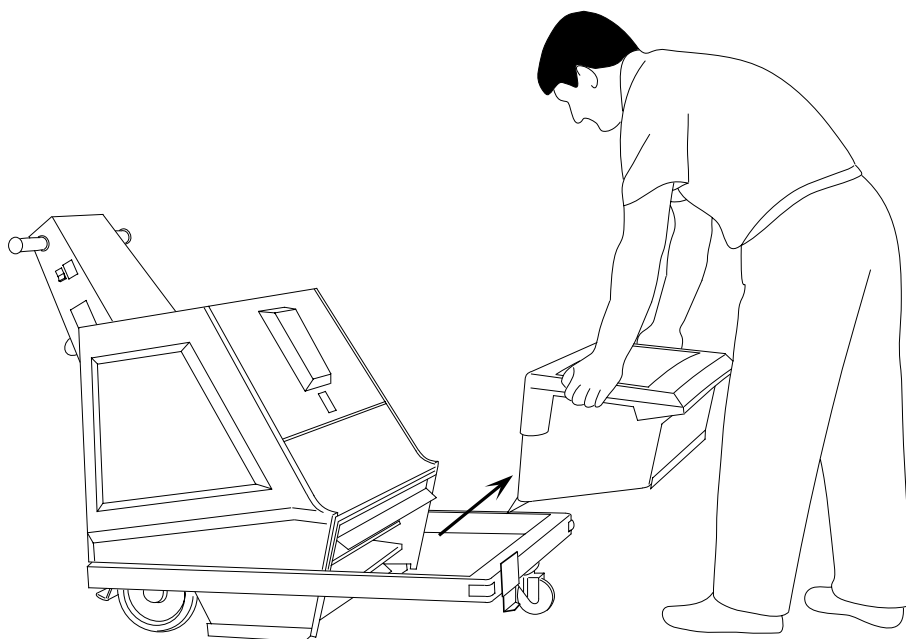

Note: Avoid sweeping wet surfaces. Moisture laden air will mix with dust accumulated on panel filter causing permanent clogging. For additional information on care and maintenance of filter, see page 10.

- 1 Push in the Shaker Motor Switch (2) to operate the filter shaker as previously described in operation section.
- 2 Empty the Hopper (16).
- 3 Put the Side Broom (17) (if so equipped) in the raised position so the bristles do not touch the floor.
- 4 Move the machine to its storage area and turn the Master Switch (9) OFF and lift the Parking Brake Lever (5).
- 5 Charge the batteries if the machine has been used for more than one hour, or when you see a double flashing light on the Battery Fuel Gauge (3). See Battery Maintenance section for additional battery information.

⚠ WARNING !

Charge batteries in a well ventilated area.

Never smoke near batteries.

Never charge batteries near an open flame or spark.

Vent battery compartment while charging batteries by opening battery compartment cover (14).

- 6 To charge, open the Battery Compartment Cover (14). Plug the battery charger into the Machine Battery Charger Plug (10), located on the left side of the Control Handle.
- 7 Follow the battery charging instructions on the battery charger.

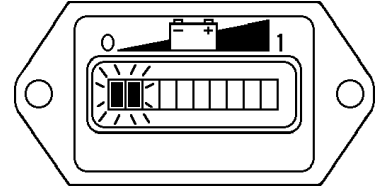

BATTERY MAINTENANCE

The fluid level in all battery cells should be checked after each charge. Add distilled water, if necessary, to bring the fluid level up to the bottom of the filler tube. Wipe any spilled water off of the batteries.

⚠ CAUTION !

Do not overfill the batteries.

Do not add water before charging the batteries.

MAINTENANCE

DUST CONTROL FILTER

⚠ CAUTION !

Wear eye protection when cleaning the filter.
Be careful not to puncture the paper in the filter.
Clean the filter in a well ventilated area.

Weekly, remove the dust control filter and clean with a vacuum or compressed air, being careful not to cause a puncture in the filter. Clean the filter compartment and reinstall the filter.

- 1 Open the Access Door (15) and remove the shaker motor assembly as shown in Figure 5.

FIGURE 5

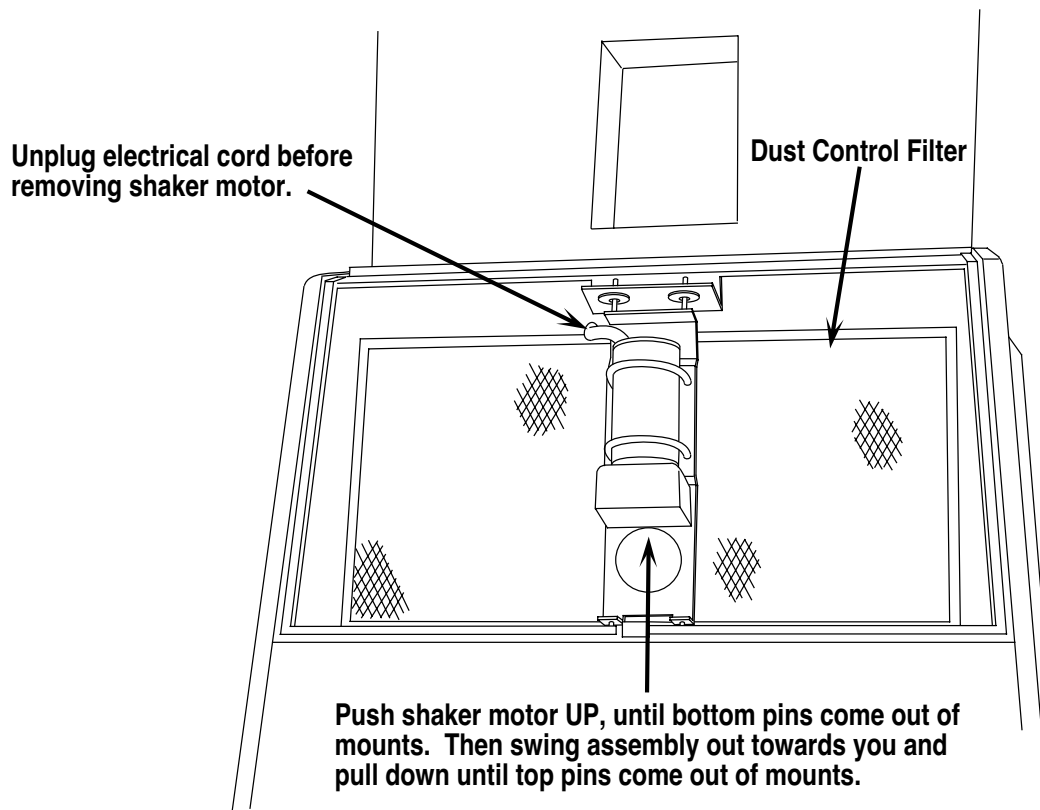

- 2 Use one of the methods below to clean the dust control filter.

Method A: Gently tap the filter to remove loose dust and dirt.

Method B: Blow compressed air (100 psi max.) into the inside (clean side) of the filter (in the opposite direction of the air flow).

Method C: Soak the filter in warm water for 15 minutes, then rinse it under a gentle stream of water (40 psi max.). Let the filter dry completely before putting it back into the machine.

LUBRICATION

There are 4 grease zerks on the rear drive axle. Use a grease gun to lubricate all zerk fittings every 6 months. Pump grease into each fitting until you can see grease seeping out around the bearings.

BROOM MAINTENANCE

⚠ WARNING !

Turn off Master Switch before servicing broom.

Periodically check the main broom housing for string, rope, wire, etc., which may be wrapped around the broom. Adjust the main broom down to compensate for wear.

To Adjust the Main Broom For Hard Floor Use...

- 1 Move the machine to a flat, smooth part of the floor.
- 2 Set the Broom Adjustment Lever (8) to position 1.
- 3 Turn on the Master Switch (9).
- 4 Turn on the Brush Switch (4) and allow the main broom to run about 30 to 60 seconds.
- 5 Turn off the main broom, move the machine and inspect the polish mark left on the floor.
- 6 Adjust the broom up or down with the Broom Adjustment Lever (8) until the polish mark is about 1 inch (2.54 cm) wide.

To Adjust the Main Broom For Use on carpet...

Follow the same adjustment procedure for hard floor use, then raise the broom one notch.

When the main broom is worn to the point where no adjustment is possible, replacement of the broom will be necessary.

To Replace the Main Broom...

⚠ WARNING !

Turn off Master Switch before servicing broom.

- 1 Remove the hopper (16).
- 2 Tip the machine back onto its kickstand (6).

⚠ WARNING !

Never work under a machine without a jackstand.

- 3 See Figure 6. Remove the 6 cap screws holding the main broom together.
- 4 Remove the 2 broom halves and install new broom. Reinstall the 6 cap screws and tighten.

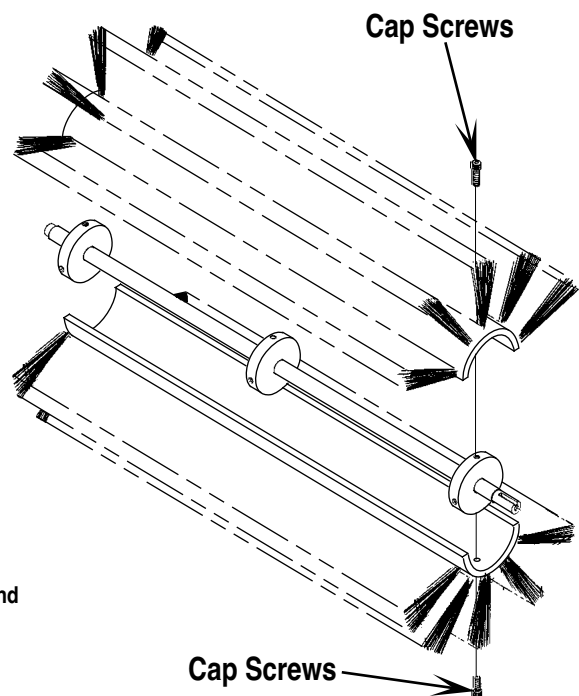
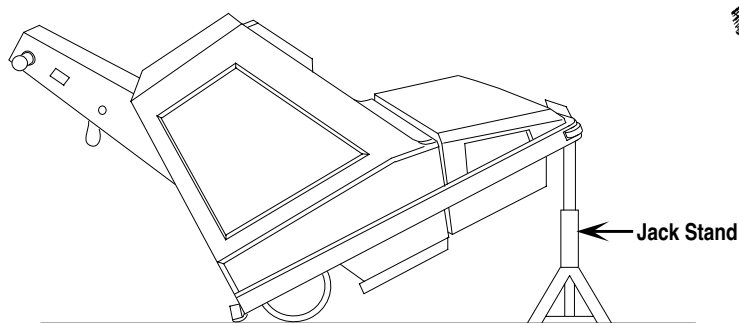

FIGURE 6

TROUBLESHOOTING

REDUCED RUNNING TIME:

- * Main broom set too low
 - * Parking brake applied
 - * Batteries need to be charged
 - * Have batteries tested by a Qualified Service Technician
-

POOR SWEEPING PERFORMANCE (MAIN BROOM)

- * Incorrect broom setting
 - * Incorrect broom, see your authorized Advance servicing dealer
 - * Full hopper
-

POOR SWEEPING PERFORMANCE (SIDE BROOM)

- * Incorrect broom setting
-

POOR DUST CONTROL

- * Clogged dust control filter
-

CIRCUIT BREAKERS

Circuit breakers protect the drive and broom motors and the control circuit from possible overload. If tripped, determine the cause of the overload, then press button to reset.

TECHNICAL SPECIFICATIONS

Model		Retriever 134B
Model No.		467215
Current	A	33
Voltage, batteries	V	24V/2 x 12V
Battery capacity	Ah	105
Sound pressure level as per ISO3744 (at operator)	dB (A)/20 μ Pa	70
Total weight (with acc. and batteries)	lbs/kg	431 / 196
Net weight (without acc. and batteries)	lbs/kg	323 / 147
Vibrations at the Hand Controls	m/s ²	<2.5m/s ²