



2015
DURANGO
USER
GUIDE





IMPORTANT

This User Guide is intended to familiarize you with the important features of your vehicle. The DVD enclosed contains your Owner's Manual, Navigation/Uconnect® Manuals, Warranty Booklets, Tire Warranty and Roadside Assistance (new vehicles purchased in the U.S.) or Roadside Assistance (new vehicles purchased in Canada) in electronic format. We hope you find it useful. Replacement DVD kits may be purchased by visiting www.techauthority.com. DODGE and Durango are registered trademarks of Chrysler Group LLC. Copyright 2014 Chrysler Group LLC.

If you are the first registered retail owner of your vehicle, you may obtain a complimentary printed copy of the Owner's Manual, Navigation/Uconnect® Manuals or Warranty Booklet by calling 1-800-423-6343 (U.S.) or 1-800-387-1143 (Canada) or by contacting your dealer.



The driver's primary responsibility is the safe operation of the vehicle. Driving while distracted can result in loss of vehicle control, resulting in a collision and personal injury. Chrysler Group LLC strongly recommends that the driver use extreme caution when using any device or feature that may take their attention off the road. Use of any electrical devices, such as cellular telephones, computers, portable radios, vehicle navigation or other devices, by the driver while the vehicle is moving is

dangerous and could lead to a serious collision. Texting while driving is also dangerous and should never be done while the vehicle is moving. If you find yourself unable to devote your full attention to vehicle operation, pull off the road to a safe location and stop your vehicle. Some states or provinces prohibit the use of cellular telephones or texting while driving. It is always the driver's responsibility to comply with all local laws.

TABLE OF CONTENTS

INTRODUCTION/WELCOME

WELCOME FROM CHRYSLER GROUP LLC	3
---------------------------------	---

CONTROLS AT A GLANCE

DRIVER COCKPIT	6
INSTRUMENT CLUSTER	8

GETTING STARTED

KEY FOB	10
REMOTE START	11
KEYLESS ENTER-N-GO™	11
VEHICLE SECURITY ALARM	15
SEAT BELT SYSTEMS	15
SUPPLEMENTAL RESTRAINT SYSTEM (SRS) — AIR BAGS	16
CHILD RESTRAINTS	19
HEAD RESTRAINTS	25
FRONT SEATS	27
REAR SEATS	31
HEATED/VENTILATED SEATS	33
HEATED STEERING WHEEL	35
TILT/TELESCOPING STEERING COLUMN	36

OPERATING YOUR VEHICLE

ENGINE BREAK-IN RECOMMENDATIONS	38
TURN SIGNAL/WIPER/WASHER/HIGH BEAM LEVER	38
HEADLIGHT SWITCH	40
ELECTRONIC SPEED CONTROL	41
ADAPTIVE CRUISE CONTROL (ACC)	43
FORWARD COLLISION WARNING (FCW) WITH MITIGATION	47
AUTOMATIC DIMMING MIRRORS	49
ELECTRONIC SHIFTER	49
AUTOSTICK	50
FUEL ECONOMY (ECO) MODE	52
AUTOMATIC CLIMATE CONTROLS	53
PARKSENSE® REAR PARK ASSIST	57
PARKVIEW® REAR BACK-UP CAMERA	57
BLIND SPOT MONITORING	58
POWER SUNROOF	58
WIND BUFFETING	59

ELECTRONICS

YOUR VEHICLE'S SOUND SYSTEM	60
IDENTIFYING YOUR RADIO	62
Uconnect® ACCESS	63
Uconnect® 5.0	80
Uconnect® 8.4A	92
Uconnect® 8.4AN	118
Uconnect® PHONE	132
STEERING WHEEL AUDIO CONTROLS	142
DRIVER INFORMATION DISPLAY (DID)	143
PROGRAMMABLE FEATURES	145

UNIVERSAL GARAGE DOOR OPENER (HomeLink®)	146
POWER INVERTER	149
POWER OUTLET	150

OFF-ROAD CAPABILITIES

ALL-WHEEL DRIVE OPERATION	152
---------------------------	-----

UTILITY

ROOF LUGGAGE RACK	154
TRAILER TOWING WEIGHTS (MAXIMUM TRAILER WEIGHT RATINGS)	154
RECREATIONAL TOWING (BEHIND MOTORHOME, ETC.)	156

WHAT TO DO IN EMERGENCIES

ROADSIDE ASSISTANCE	161
INSTRUMENT CLUSTER WARNING LIGHTS	161
INSTRUMENT CLUSTER INDICATOR LIGHTS	166
IF YOUR ENGINE OVERHEATS	168
JACKING AND TIRE CHANGING	169
BATTERY LOCATION	180
JUMP-STARTING	180
MANUAL PARK RELEASE	182
TOWING A DISABLED VEHICLE	184
FREEING A STUCK VEHICLE	185
EVENT DATA RECORDER (EDR)	186
CAP-LESS FUEL FILL FUNNEL	186

MAINTAINING YOUR VEHICLE

OPENING THE HOOD	187
ENGINE COMPARTMENT	188
FLUID CAPACITIES	192
FLUIDS, LUBRICANTS AND GENUINE PARTS	192
MAINTENANCE PROCEDURES	194
MAINTENANCE SCHEDULE	194
MAINTENANCE RECORD	198
FUSES	199
TIRE PRESSURES	202
ADDING FUEL	203
SPARE TIRES — IF EQUIPPED	205
WHEEL AND WHEEL TRIM CARE	206
REPLACEMENT BULBS	207

CUSTOMER ASSISTANCE

CHRYSLER GROUP LLC CUSTOMER CENTER	208
CHRYSLER CANADA INC. CUSTOMER CENTER	208
ASSISTANCE FOR THE HEARING IMPAIRED	208
PUBLICATIONS ORDERING	208
REPORTING SAFETY DEFECTS IN THE UNITED STATES	209



TABLE OF CONTENTS

MOPAR® ACCESSORIES

AUTHENTIC ACCESSORIES BY
MOPAR® 210

FREQUENTLY ASKED QUESTIONS

FREQUENTLY ASKED QUESTIONS 211

INDEX 213

INTRODUCTION/WELCOME

WELCOME FROM CHRYSLER GROUP LLC

Congratulations on selecting your new Chrysler Group LLC vehicle. Be assured that it represents precision workmanship, distinctive styling, and high quality - all essentials that are traditional to our vehicles.

Your new Chrysler Group LLC vehicle has characteristics to enhance the driver's control under some driving conditions. These are to assist the driver and are never a substitute for attentive driving. They can never take the driver's place. Always drive carefully.

Your new vehicle has many features for the comfort and convenience of you and your passengers. Some of these should not be used when driving because they take your eyes from the road or your attention from driving. Never text while driving or take your eyes more than momentarily off the road.

This guide illustrates and describes the operation of features and equipment that are either standard or optional on this vehicle. This guide may also include a description of features and equipment that are no longer available or were not ordered on this vehicle. Please disregard any features and equipment described in this guide that are not available on this vehicle. Chrysler Group LLC reserves the right to make changes in design and specifications and/or make additions to or improvements to its products without imposing any obligation upon itself to install them on products previously manufactured.

This User Guide has been prepared to help you quickly become acquainted with the important features of your vehicle. It contains most things you will need to operate and maintain the vehicle, including emergency information.

The DVD includes a computer application containing detailed owner's information which can be viewed on a personal computer or MAC computer. The multimedia DVD also includes videos which can be played on any standard DVD player (including the Uconnect® Touchscreen Radios if equipped with DVD player capabilities). Additional DVD operational information is located on the back of the DVD sleeve.

For complete owner information, refer to your Owner's Manual on the DVD in the owner's kit provided at the time of new vehicle purchase. For your convenience, the information contained on the DVD may also be printed and saved for future reference.

Chrysler Group LLC is committed to protecting our environment and natural resources. By converting from paper to electronic delivery for the majority of the user information for your vehicle, together we greatly reduce the demand for tree-based products and lessen the stress on our environment.

INTRODUCTION/WELCOME

VEHICLES SOLD IN CANADA

With respect to any vehicles sold in Canada, the name Chrysler Group LLC shall be deemed to be deleted and the name Chrysler Canada Inc. used in substitution (excluding legal lines).

WARNING!

- Pedals that cannot move freely can cause loss of vehicle control and increase the risk of serious personal injury.
- Always make sure that objects cannot fall into the driver foot well while the vehicle is moving. Objects can become trapped under the brake pedal and accelerator pedal causing a loss of vehicle control.
- Failure to properly follow floor mat installation or mounting can cause interference with the brake pedal and accelerator pedal operation causing loss of control of the vehicle.
- Never leave children alone in a vehicle, or with access to an unlocked vehicle. Allowing children to be in a vehicle unattended is dangerous for a number of reasons. A child or others could be seriously or fatally injured. Children should be warned not to touch the parking brake, brake pedal or the shift lever/transmission gear selector.
- Do not leave the key fob in or near the vehicle, or in a location accessible to children, and do not leave the ignition of a vehicle equipped with Keyless Enter-N-Go in the ACC or ON/RUN mode. A child could operate power windows, other controls, or move the vehicle.
- Never use the "PARK" position as a substitute for the parking brake. Always apply the parking brake fully when parked to guard against vehicle movement and possible injury or damage.
- Refer to your Owner's Manual on the DVD for further details.

Rollover Warning



WARNING!

- Pedals that cannot move freely can cause loss of vehicle control and increase the risk of serious personal injury.
- Always make sure that objects cannot fall into the driver foot well while the vehicle is moving. Objects can become trapped under the brake pedal and accelerator pedal causing a loss of vehicle control.
- Failure to properly follow floor mat installation or mounting can cause interference with the brake pedal and accelerator pedal operation causing loss of control of the vehicle.
- Refer to your Owner's Manual on the DVD for further details.
- Never use the 'PARK' position as a substitute for the parking brake. Always apply the parking brake fully when parked to guard against vehicle movement and possible injury or damage.

USE OF AFTERMARKET PRODUCTS (ELECTRONICS)

The use of aftermarket devices including cell phones, MP3 players, GPS systems, or chargers may affect the performance of on-board wireless features including Keyless Enter-N-Go™ and Remote Start range. If you are experiencing difficulties with any of your wireless features, try disconnecting your aftermarket devices to see if the situation improves. If your symptoms persist, please see an authorized dealer.

CHRYSLER, DODGE, JEEP, RAM, MOPAR and Uconnect are registered trademarks of Chrysler Group LLC.

COPYRIGHT ©2014 CHRYSLER GROUP LLC



CONTROLS AT A GLANCE

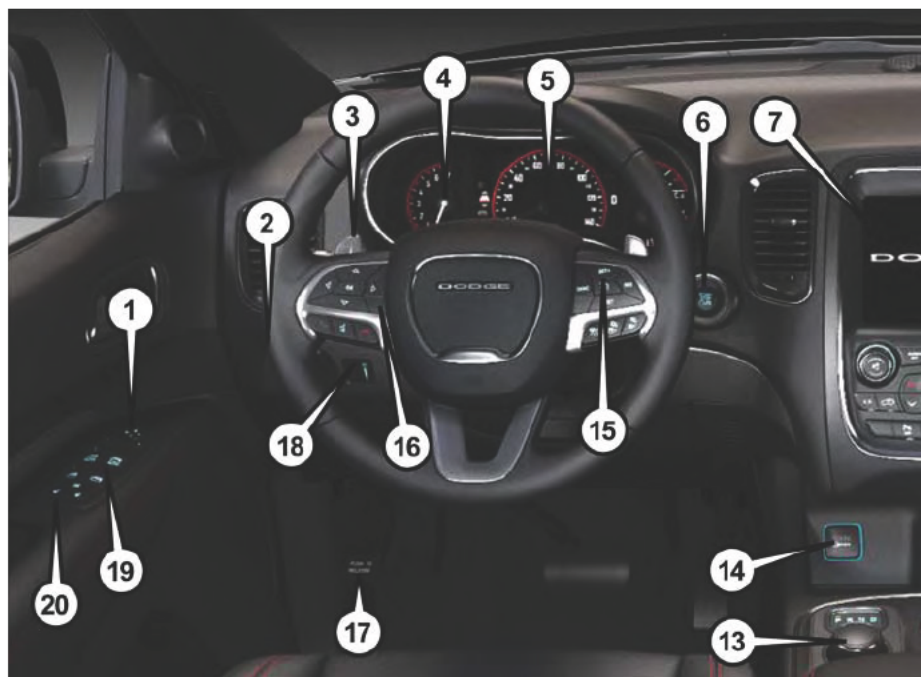

DRIVER COCKPIT

1. Power Mirror Controls
2. Headlight Switch pg. 40
3. Shifter Paddle (AutoStick) pg. 50
4. Instrument Cluster pg. 8
5. Driver Information Display (DID)
6. Engine Start/Stop Button (Behind Steering Wheel) pg. 13
7. Audio System (Touchscreen Radio Shown) pg. 62
8. Passenger Power Window Controls
9. Glove Compartment
10. Audio Browse/Enter Button pg. 80

CONTROLS AT A GLANCE

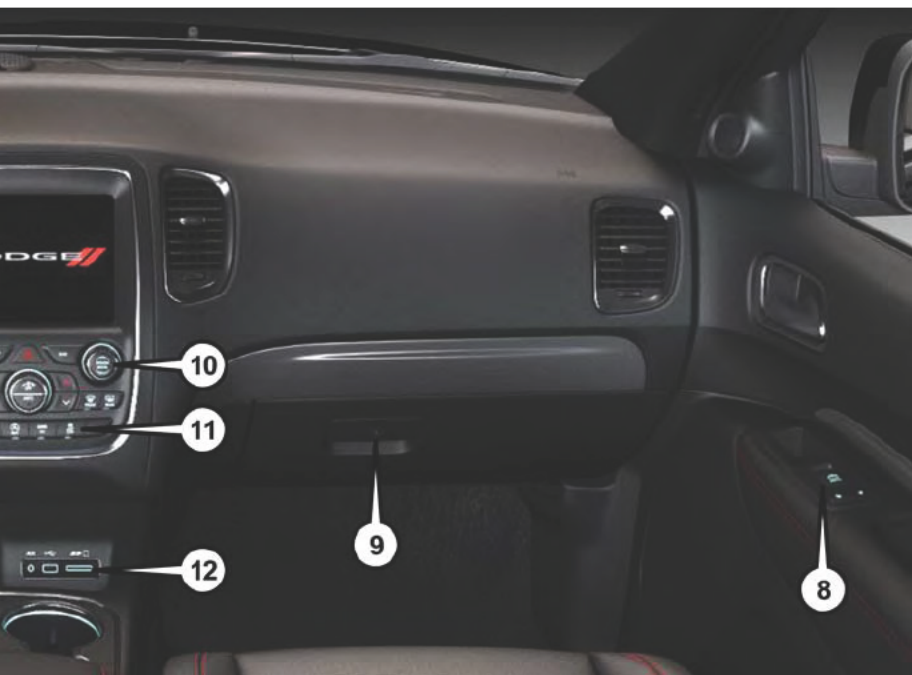

11. Switch Panel

- ParkSense® pg. 57
- ECO On pg. 52
- Electronic Stability Control (ESC) OFF pg. 167
- Forward Collision Warning (FCW) pg. 47

12. Media Hub

- Audio Jack (AUX)
- USB Port
- SD Port

13. Transmission Gear Selector pg. 49

14. Front Power Outlet pg. 150

15. Speed Control pg. 41

16. Driver Information Display Controls pg. 143

17. Parking Brake Release

18. Instrument Panel Dimmer pg. 40

19. Power Windows

20. Power Door Locks

CONTROLS AT A GLANCE



INSTRUMENT CLUSTER

1. Tachometer
2. Speedometer

(See page 161 for Instrument Cluster Warning Lights.)

CONTROLS AT A GLANCE



3. Temperature Gauge

4. Fuel Gauge

(See page 166 for Instrument Cluster Indicator Lights.)

GETTING STARTED

KEY FOB

Locking And Unlocking The Doors And Liftgate

Lock The Doors And Liftgate

- Push and release the LOCK button on the RKE transmitter to lock all doors and liftgate. The turn signal lights will flash, and the horn will chirp to acknowledge the signal.

Unlock The Doors And Liftgate

- Push and release the UNLOCK button on the RKE transmitter once to unlock the driver's door or twice within five seconds to unlock all doors and liftgate. The turn signal lights will flash to acknowledge the unlock signal. The illuminated entry system will also turn on.

All doors can be programmed to unlock on the first push of the UNLOCK button. Refer to "Programmable Features" in the "Electronics" section of this guide.



Key Fob

- | | |
|--------------|------------------|
| 1 — Liftgate | 4 — Remote Start |
| 2 — Unlock | 5 — Panic |
| 3 — Lock | |

POWER LIFTGATE

- Push the LIFTGATE button  twice within five seconds to power open/close the Power Liftgate. If the button is pushed while the liftgate is being power closed, the liftgate will reverse to the full open position.
- Also, the Power Liftgate may be closed by pushing the liftgate switch located on the left rear trim panel, near the liftgate opening. Pushing once will close the liftgate only. This button cannot be used to open the liftgate.

Panic Alarm

1. Push the PANIC button once to turn the panic alarm on.
2. Wait approximately three seconds and push the button a second time to turn the panic alarm off.

REMOTE START

- Push the REMOTE START button  on the Key Fob twice within five seconds. Pushing the REMOTE START button a third time shuts the engine off.
- To drive the vehicle, with a valid Keyless Enter-N-Go™ Key Fob within 5 ft (1.5m) of the driver's side of the vehicle, grab the front driver door handle to unlock the driver's door automatically and then push the Start/Stop switch, or push the UNLOCK button, insert the Key Fob in the ignition and turn to the ON/RUN position.
- With remote start, the engine will only run for 15 minutes (timeout) unless the ignition is placed in the ON/RUN position.
- The vehicle must be started with the Key Fob after two consecutive timeouts.

WARNING!

- Do not start or run an engine in a closed garage or confined area. Exhaust gas contains Carbon Monoxide (CO) which is odorless and colorless. Carbon Monoxide is poisonous and can cause you or others to be severely injured or killed when inhaled.
- Keep Key Fob transmitters away from children. Operation of the Remote Start System, windows, door locks or other controls could cause you and others to be severely injured or killed.

KEYLESS ENTER-N-GO™

The Keyless Enter-N-Go™ system is an enhancement to the vehicle's Key Fob. This feature allows you to lock and unlock the vehicle's door(s) and liftgate without having to push the Key Fob lock or unlock buttons as well as starting and stopping the vehicle with the push of a button.

GETTING STARTED

To Unlock From The Driver Or Passenger Side

- With a valid Keyless Enter-N-Go™ Key Fob located outside the vehicle and within 5 ft (1.5m) of the driver or passenger side door handle, grab either front door handle to unlock the door automatically.



Grab The Door Handle To Unlock

To Lock The Vehicle

- Both front door handles have buttons located on the outside of the handle. With one of the vehicle's Keyless Enter-N-Go™ Key Fobs located outside the vehicle and within 5 ft (1.5m) of the driver's or passenger front door handle, push the door handle button to lock all four doors and liftgate.
- DO NOT grab the door handle when pushing the door handle lock button. This could unlock the door(s).



Push The Door Handle Button To Lock



Do NOT Grab Handle When Locking

NOTE:

- "1st Press of Key Fob Unlocks" has two options available. "Driver Door" and "All Doors" will unlock when you grab hold of the front driver's door handle. To select between "Driver Door" and "All Doors," refer to "Uconnect® Settings" in your vehicle's Owner's Manual on the DVD.
- If a Key Fob is detected in the vehicle when locking the vehicle using the power door lock switch, the doors and liftgate will unlock, and the horn will chirp three times. On the third attempt, your Key Fob can be locked inside the vehicle.

- After pushing the Keyless Enter-N-Go™ LOCK button, you must wait two seconds before you can lock or unlock the vehicle using the door handle. This is done to allow you to check if the vehicle is locked by pulling the door handle, without the vehicle reacting and unlocking.
- If a Keyless Enter-N-Go™ door handle has not been used for 72 hours, the Keyless Enter-N-Go™ feature for that handle may time out. Pulling the deactivated front door handle will reactivate the door handle's Keyless Enter-N-Go™ feature.

Lock Or Unlock The Liftgate

- To Lock The Liftgate — With a Remote Keyless Entry (RKE) transmitter within 3 ft (1.0 m) of the liftgate, push the passive entry lock button located to the right of electronic liftgate handle.
- To Unlock/Enter The Liftgate — The liftgate passive entry unlock feature is built into the electronic liftgate handle. With a Remote Keyless Entry (RKE) transmitter within 3 ft (1.0 m) of the liftgate, push the electronic release switch to open the liftgate.

NOTE:

Refer to your Owner's Manual on the DVD for further information.



Electronic Liftgate Handle

- 1 — Electronic Release Switch
- 2 — Lock Button Location

Engine Starting/Stopping

Starting

Perform the following starting procedure with a Remote Keyless Entry (RKE) transmitter inside the vehicle:

1. While pushing the brake pedal, push the ENGINE START/STOP button once. If the engine fails to start, the starter will disengage automatically after 10 seconds.
2. To stop the cranking of the engine prior to the engine starting, push the button again.



Engine START/STOP Button

GETTING STARTED

Stopping

1. Bring the vehicle to a complete stop.
2. Shift the Transmission to PARK (P).
3. Push the ENGINE START/STOP button once. The ignition switch will return to the OFF position.

NOTE:

If the transmission is not in PARK and the vehicle is in motion, the ENGINE START/STOP button must be held for two seconds with the vehicle speed above 5 mph (8 km/h) before the engine will shut off.

Accessory Positions With Engine Off

NOTE:

The following functions are with the driver's foot off of the Brake Pedal (transmission in PARK or NEUTRAL).

Beginning With The Ignition Switch In The OFF Position:

1. Push the ENGINE START/STOP button once to cycle the ignition to the ACC position.
2. Push the ENGINE START/STOP button a second time to cycle the ignition to the ON/RUN position.
3. Push the ENGINE START/STOP button a third time to return the ignition to the OFF position.

NOTE:

If the ignition is left in the ACC or ON/RUN (engine not running) position and the transmission is in PARK, the system will automatically time out after 30 minutes of inactivity, and the ignition is returned to the OFF position.

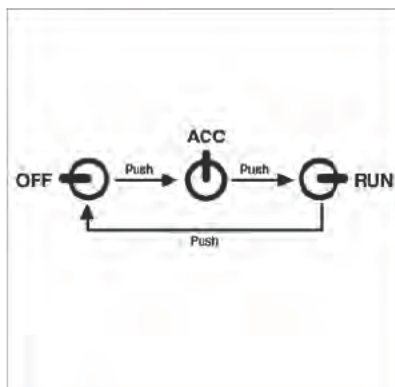

Ignition Positions

VEHICLE SECURITY ALARM

The Vehicle Security Alarm monitors the vehicle doors for unauthorized entry and the Keyless Enter-N-Go™ START/STOP button for unauthorized operation. While the Vehicle Security Alarm is armed, interior switches for door locks and decklid release are disabled. If something triggers the alarm, the Vehicle Security Alarm will provide the following audible and visible signals: the horn will pulse, the park lamps and/or turn signals will flash, and the Vehicle Security Light in the instrument cluster will flash.

To Arm

Cycle the Keyless Enter-N-Go™ START/STOP button until the button display indicates that the vehicle ignition is “OFF.” Push the power door lock switch while the door is open, push the Key Fob LOCK button, or with one of the Key Fobs located outside the vehicle and within 5 ft (1.5 m) of the driver's and passenger front door handles, push the Keyless Enter-N-Go™ LOCK button located on the door handle.

NOTE:

After pushing the Keyless Enter-N-Go™ LOCK button, you must wait two seconds before you can lock or unlock the vehicle via the door handle.

To Disarm

Push the Key Fob UNLOCK button or with one of the Key Fobs located outside the vehicle and within 5 ft (1.5 m) of the driver's and passenger front door handles. Grab the Keyless Enter-N-Go™ door handle and enter the vehicle, then push the Keyless Enter-N-Go™ START/STOP button (requires at least one valid Key Fob in the vehicle).

SEAT BELT SYSTEMS

Lap/Shoulder Belts

- All seating positions in your vehicle are equipped with lap/shoulder belts.
- Be sure everyone in your vehicle is in a seat and using a seat belt properly.
- Position the lap belt so that it is snug and lies low across your hips, below your abdomen. To remove slack in the lap belt portion, pull up on the shoulder belt. To loosen the lap belt if it is too tight, tilt the latch plate and pull on the lap belt. A snug seat belt reduces the risk of sliding under the seat belt in a collision.
- Position the shoulder belt across the shoulder and chest with minimal, if any slack so that it is comfortable and not resting on your neck. The retractor will withdraw any slack in the shoulder belt.

Seat Belt Pretensioner

- The front seat belt system is equipped with pretensioning devices that are designed to remove slack from the seat belt in the event of a collision.
- A deployed pretensioner or a deployed air bag must be replaced immediately.

GETTING STARTED

WARNING!

- In a collision, you and your passengers can suffer much greater injuries if you are not properly buckled up. You can strike the interior of your vehicle or other passengers, or you can be thrown out of the vehicle. Always be sure you and others in your vehicle are buckled up properly.
- A shoulder belt placed behind you will not protect you from injury during a collision. You are more likely to hit your head in a collision if you do not wear your shoulder belt. The lap and shoulder belt are meant to be used together.
- A seat belt that is too loose will not protect you properly. In a sudden stop, you could move too far forward, increasing the possibility of injury. Wear your seat belt snugly.
- A frayed or torn seat belt could rip apart in a collision and leave you with no protection. Inspect the seat belt system periodically, checking for cuts, frays, or loose parts. Damaged parts must be replaced immediately. Do not disassemble or modify the system. Seat belt assemblies must be replaced after a collision.

SUPPLEMENTAL RESTRAINT SYSTEM (SRS) — AIR BAGS

Air Bag System Components

Your vehicle may be equipped with the following air bag system components:

- Occupant Restraint Controller (ORC)
- Air Bag Warning Light
- Steering Wheel and Column
- Instrument Panel
- Knee Impact Bolsters
- Advanced Front Air Bags
- Supplemental Side Air Bags
- Supplemental Knee Air Bags
- Front and Side Impact Sensors
- Seat Belt Pretensioners
- Seat Belt Buckle Switch
- Seat Track Position Sensors

Advanced Front Air Bags

- This vehicle has Advanced Front Air Bags for both the driver and front passenger as a supplement to the seat belt restraint systems. The Advanced Front Air Bags will not deploy in every type of collision.
- Advanced Front Air Bags are designed to provide additional protection by supplementing the seat belts. Advanced Front Air Bags are not expected to reduce the risk of injury in rear, side, or rollover collisions.

- The Advanced Front Air Bags will not deploy in all frontal collisions, including some that may produce substantial vehicle damage — for example, some pole collisions, truck underrides, and angle offset collisions.
- On the other hand, depending on the type and location of impact, Advanced Front Air Bags may deploy in crashes with little vehicle front-end damage but that produce a severe initial deceleration.
- Because air bag sensors measure vehicle deceleration over time, vehicle speed and damage by themselves are not good indicators of whether or not an air bag should have deployed.
- Seat belts are necessary for your protection in all collisions, and also are needed to help keep you in position, away from an inflating air bag.
- The air bags must be ready to inflate for your protection in a collision. The Occupant Restraint Controller (ORC) monitors the internal circuits and interconnecting wiring associated with air bag system electrical components.
- The ORC turns on the Air Bag Warning Light in the instrument panel for approximately four to eight seconds for a self-check when the ignition switch is first turned to the ON/RUN position. After the self-check, the Air Bag Warning Light will turn off. If the ORC detects a malfunction in any part of the system, it turns on the Air Bag Warning Light, either momentarily or continuously. A single chime will sound to alert you if the light comes on again after initial startup.
- The ORC monitors the readiness of the electronic parts of the air bag system whenever the ignition switch is in the START or ON/RUN position. If the ignition switch is in the OFF position or in the ACC position, the air bag system is not on and the air bags will not inflate.
- If the Air Bag Warning Light in the instrument panel is not on during the four to eight seconds when the ignition switch is first turned to the ON/RUN position, stays on, or turns on while driving, have the vehicle serviced by an authorized service center immediately.

NOTE:

If the speedometer, tachometer, or any engine related gauges are not working, the Occupant Restraint Controller (ORC) may also be disabled. In this condition the air bags may not be ready to inflate for your protection. Have an authorized dealer service the air bag system immediately.

- After any collision, the vehicle should be taken to an authorized dealer immediately.
- Do not drive your vehicle after the air bags have deployed. If you are involved in another collision, the air bags will not be in place to protect you.
- If it is necessary to modify the air bag system for persons with disabilities, contact your authorized dealer.
- Refer to the Owner's Manual on the DVD for further details regarding the Supplemental Restraint System (SRS).

GETTING STARTED

Supplemental Knee Air Bags

This vehicle is equipped with a Supplemental Driver Knee Air Bag mounted in the instrument panel below the steering column. The Supplemental Driver Knee Air Bag provides enhanced protection during a frontal impact by working together with the seat belts, pretensioners, and Advanced Front Air Bags.

WARNING!

- Relying on the air bags alone could lead to more severe injuries in a collision. The air bags work with your seat belt to restrain you properly. In some collisions, the air bags won't deploy at all. Always wear your seat belts even though you have air bags.
- Being too close to the steering wheel or instrument panel during Advanced Front Air Bag deployment could cause serious injury, including death. Air bags need room to inflate. Sit back, comfortably extending your arms to reach the steering wheel or instrument panel.
- No objects should be placed over or near the air bag on the instrument panel or steering wheel because any such objects could cause harm if the vehicle is in a collision severe enough to cause the air bag to inflate.

Supplemental Side Air Bags

- This vehicle is equipped with Supplemental Seat-Mounted Side Air Bags (SABs) located in the outboard side of the front seats. The SABs are marked with a SRS AIRBAG or AIRBAG label sewn into the outboard side of the seats.
- This vehicle is equipped with Supplemental Side Air Bag Inflatable Curtains (SABICs) located above the side windows. The trim covering the SABICs is labeled SRS AIRBAG or AIRBAG. The SABICs may help reduce the risk of partial or complete ejection of vehicle occupants through side windows in certain side impact events.
- The SABICs and SABs ("Side Air Bags") are designed to activate in certain side impacts and certain rollover events. The Occupant Restraint Controller ("ORC") determines whether the deployment of the Side Air Bags in a particular side impact or rollover event is appropriate, based on the severity and type of collision. Vehicle damage by itself is not a good indicator of whether or not Side Air Bags should have deployed.

WARNING!

- Side Air Bags need room to inflate. Do not lean against the door or window. Sit upright in the center of the seat.
- Being too close to the Side Air Bags during deployment could cause you to be severely injured or killed.
- Relying on the Side Air Bags alone could lead to more severe injuries in a collision. The Side Air Bags work with your seat belt to restrain you properly. In some collisions, Side Air Bags won't deploy at all. Always wear your seat belt even though you have Side Air Bags.
- This vehicle is equipped with left and right Supplemental Side Air Bag Inflatable Curtains (SABICs). Do not stack luggage or other cargo up high enough to block the deployment of the SABICs. The trim covering above the side windows where the SABIC and its deployment path are located should remain free from any obstructions.
- This vehicle is equipped with SABICs. In order for the SABICs to work as intended, do not install any accessory items in your vehicle which could alter the roof. Do not add an aftermarket sunroof to your vehicle. Do not add roof racks that require permanent attachments (bolts or screws) for installation on the vehicle roof. Do not drill into the roof of the vehicle for any reason.
- Do not use accessory seat covers or place objects between you and the Side Air Bags; the performance could be adversely affected and/or objects could be pushed into you, causing serious injury.

CHILD RESTRAINTS

Children 12 years or younger should ride properly buckled up in a rear seat, if available. According to crash statistics, children are safer when properly restrained in the rear seats rather than in the front.

Every state in the United States and all Canadian provinces require that small children ride in proper restraint systems. This is the law, and you can be prosecuted for ignoring it.

NOTE:

- For additional information, refer to www.Seatcheck.org or call 1-866-SEATCHECK.
- Canadian residents should refer to Transport Canada's website for additional information: <http://www.tc.gc.ca/eng/motorvehiclesafety/safedrivers-childsafety-index-53.htm>

LATCH – Lower Anchors And Tethers For Children

- Your vehicle is equipped with the child restraint anchorage system called LATCH, which stands for Lower Anchors and Tethers for Children.
- The second row seating positions have lower anchors and top tether anchors. The second row center (60/40 bench seat only) and third row seating positions have a top tether anchor only.

GETTING STARTED

LATCH System Weight Limit

You may use the LATCH anchorage system until the combined weight of the child and the child restraint is 65 lbs (29.5 kg). Use the seat belt and tether anchor instead of the LATCH system once the combined weight is more than 65 lbs (29.5 kg).

Locating LATCH Anchorages

 The lower anchorages are round bars that are found at the rear of the seat cushion where it meets the seatback. They are just visible when you lean into the rear seat to install the child restraint. You will easily feel them if you run your finger along the gap between the seatback and seat cushion.



Lower Anchors

Locating Tether Anchorages

 In addition, there are tether strap anchorages behind each rear seating position located on the back of the seat. To access the top tether strap anchorages behind the 60/40 Center Row Bench seat or the third row seat, pull the carpeted floor panel away from the seat back, this will expose the top tether strap anchorages. **DO NOT USE** the cargo tie down loops located on the load floor as tether anchorages.

Center Seat LATCH

Do not install a child restraint in the center position using the LATCH system. Use the seat belt and tether anchor to install a child seat in the center seating position.



Tether Anchors Second Row

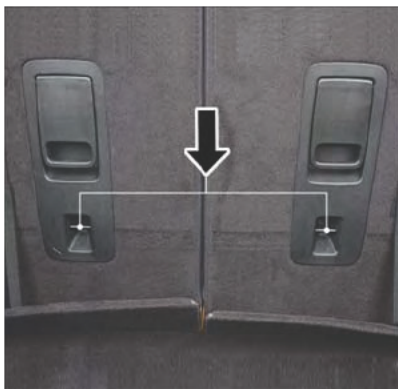

Tether Anchors Third Row

GETTING STARTED

Vehicles With Center Arm Rest Tether

For rearward facing infant seats secured in the center seat position with the vehicle seat belts, the rear center seat position has an armrest tether that secures the arm rest in the upward position.

1. To access the center seat arm rest tether, first lower the arm rest. The tether is located behind the armrest and hooked onto the plastic seat backing.
2. Pull down on the tether to unhook it from the plastic seat backing.



Center Seat Position Arm Rest Tether

3. Raise the armrest and attach the tether hook to the strap located on the front of the arm rest.



Center Seat Arm Rest Raised Displaying The Tether

Installing The Child Restraint Using The LATCH Lower Anchors

NOTE:

Never “share” a LATCH anchorage with two or more child restraints.

1. Loosen the adjusters on the lower straps and on the tether strap of the child seat so that you can more easily attach the hooks or connectors to the vehicle anchorages.
2. Attach the lower hooks or connectors of the child restraint to the lower anchorages in the selected seating position.
3. If the child restraint has a tether strap, connect it to the top tether anchorage. See below for directions to attach a tether anchor.
4. Tighten all of the straps as you push the child restraint rearward and downward into the seat. Remove slack in the straps according to the child restraint manufacturer's instructions.
5. Test that the child restraint is installed tightly by pulling back and forth on the child seat at the belt path. It should not move more than 1 inch (25.4 mm) in any direction.

Installing The Child Restraint Using The Vehicle Seat Belts

The seat belts in the passenger seating positions are equipped with a Switchable Automatic Locking Retractor (ALR) that is designed to keep the lap portion of the seat belt tight around the child restraint. Any seat belt system will loosen with time, so check the belt occasionally, and pull it tight if necessary.

Tether Anchorage Weight Limit

Always use the tether anchor when using the seat belt to install a forward facing child restraint, up to the recommended weight limit of the child restraint.

To Install A Child Seat Using An ALR:

1. Pull enough of the seat belt webbing from the retractor to pass it through the belt path of the child restraint. Do not twist the belt webbing in the belt path.
2. Slide the latch plate into the buckle until you hear a “click.”
3. Pull on the webbing to make the lap portion tight against the child seat.
4. To lock the seat belt, pull down on the shoulder part of the belt until you have pulled all the seat belt webbing out of the retractor. Then, allow the webbing to retract back into the retractor. As the webbing retracts, you will hear a clicking sound. This means the seat belt is now in the Automatic Locking mode.
5. Try to pull the webbing out of the retractor. If it is locked, you should not be able to pull out any webbing. If the retractor is not locked, repeat the last step.
6. Finally, pull up on any extra webbing to tighten the lap portion around the child restraint while you push the child restraint rearward and downward into the vehicle seat.
7. If the child restraint has a top tether strap and the seating position has a top tether anchorage, connect the tether strap to the anchorage and tighten the tether strap. See below for directions to attach a tether anchor.
8. Test that the child restraint is installed tightly by pulling back and forth on the child seat at the belt path. It should not move more than 1 inch (25.4 mm) in any direction.

Installing The Top Tether Strap (With Either Lower Anchors Or Vehicle Seat Belt):

When installing a forward-facing child restraint, always secure the top tether strap, up to the tether anchor weight limit, whether the child restraint is installed with the lower anchors or the vehicle seat belt.

GETTING STARTED

Tether Strap Installation

1. To access the top tether strap anchorages behind the rear seat, pull the carpeted floor panel away from the seat back, this will expose the top tether strap anchorages.
2. Route the tether strap to provide the most direct path for the strap between the anchor and the child seat.
3. If your vehicle is equipped with adjustable rear head restraints, raise the head restraint, and where possible, route the tether strap under the head restraint and between the two posts. If not possible, lower the head restraint and pass the tether strap around the outboard side of the head restraint.
4. For the center seating position, route the tether strap over the seatback and headrest.
5. Attach the tether strap hook of the child restraint to the top tether anchorage and remove slack in the tether strap according to the child restraint manufacturer's instructions. **DO NOT USE** the cargo tie down loops located on the load floor as tether anchorages.



Top Tether Strap Mounting (60/40 Seat)



Top Tether Strap Mounting (Captain's Chair)

WARNING!

- In a collision, an unrestrained child, even a tiny baby, can become a projectile inside the vehicle. The force required to hold even an infant on your lap could become so great that you could not hold the child, no matter how strong you are. The child and others could be severely injured or killed. Any child riding in your vehicle should be in a proper restraint for the child's size.
- Rearward-facing child seats must never be used in the front seat of a vehicle with a front passenger air bag. An air bag deployment could cause severe injury or death to infants in this position.
- Only use a rearward-facing child restraint in a vehicle with a rear seat.
- Improper installation of a child restraint to the LATCH anchorages can lead to failure of an infant or child restraint. The child could be severely injured or killed. Follow the manufacturer's directions exactly when installing an infant or child restraint.
- An incorrectly anchored tether strap could lead to increased head motion and possible injury to the child. Use only the anchor positions directly behind the child seat to secure a child restraint top tether strap.
- If your vehicle is equipped with a split rear seat, make sure the tether strap does not slip into the opening between the seatbacks as you remove slack in the strap.

HEAD RESTRAINTS

Head restraints are designed to reduce the risk of injury by restricting head movement in the event of a rear-impact. Head restraints should be adjusted so that the top of the head restraint is located above the top of your ear.

WARNING!

The head restraints for all occupants must be properly adjusted prior to operating the vehicle or occupying a seat. Head restraints should never be adjusted while the vehicle is in motion. Driving a vehicle with the head restraints improperly adjusted or removed could cause serious injury or death in the event of a collision.

Active Head Restraints — Front Seats

Active Head Restraints are passive, deployable components, and vehicles with this equipment cannot be readily identified by any markings, only through visual inspection of the head restraint. The Active Head Restraints (AHR) will be split in two halves, with the front half being soft foam and trim, the back half being decorative plastic.

When AHRs deploy during a rear impact, the front half of the head restraint extends forward to minimize the gap between the back of the occupant's head and the AHR. This system is designed to help prevent or reduce the extent of injuries to the driver and front passenger in certain types of rear impacts. Refer to "Occupant Restraints" in your Owner's Manual on the DVD for further information.

GETTING STARTED

To raise the head restraint, pull upward on the head restraint. To lower the head restraint, press the push button, located at the base of the head restraint, and push downward on the head restraint.

For comfort the Active Head Restraints can be tilted forward and rearward. To tilt the head restraint closer to the back of your head, pull forward on the bottom of the head restraint. Push rearward on the bottom of the head restraint to move the head restraint away from your head.

NOTE:

- The head restraints should only be removed by qualified technicians, for service purposes only. If either of the head restraints require removal, see your authorized dealer.
- In the event of deployment of an Active Head Restraint, refer to “Occupant Restraints” in your Owner’s Manual on the DVD for further information.

WARNING!

- Do not place items over the top of the Active Head Restraint, such as coats, seat covers or portable DVD players. These items may interfere with the operation of the Active Head Restraint in the event of a collision and could result in serious injury or death.
- Active Head Restraints may be deployed if they are struck by an object such as a hand, foot or loose cargo. To avoid accidental deployment of the Active Head Restraint ensure that all cargo is secured, as loose cargo could contact the Active Head Restraint during sudden stops. Failure to follow this warning could cause personal injury if the Active Head Restraint is deployed.

Head Restraints — Rear Seats

The head restraints on the outboard seats are not adjustable. They automatically fold forward when the rear seat is folded to a load floor position but do not return to their normal position when the rear seat is raised. After returning either seat to its upright position, raise the head restraint until it locks in place. The outboard head restraints are not removable.

The center head restraint has limited adjustment. Lift upward on the head restraint to raise it, or push downward on the head restraint to lower it.

WARNING!

Sitting in a seat with the head restraint in its lowered position could result in serious injury or death in a collision. Always make sure the outboard head restraints are in their upright positions when the seat is to be occupied.

NOTE:

For proper routing of a Child Seat Tether refer to “Occupant Restraints” in your Owner’s Manual on the DVD for further information.

Power Folding Third Row Head Restraints

For improved visibility when in reverse, the third row head restraints can be folded using the Uconnect® System.

Press the “Controls” button located on the bottom of the Uconnect® display.

Press the Headrest Fold button  to power fold the third row head restraints.

NOTE:

- The head restraints can only be folded downward using the Headrest button. The head restraints must be raised manually when occupying the third row.
- Do not fold if there are passengers seated in the third row seats.

FRONT SEATS

Power Seats

The power recline switch, located on the outboard side of the seat, controls seatback adjustment.

The power seat switch controls forward/back, up/down and tilt adjustment.

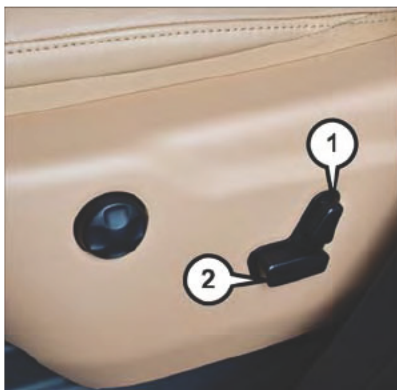

Power Seat Switches

- 1 — Recline Switch
2 — Power Seat Switch
-

GETTING STARTED

Power Lumbar

- Push the switch forward to increase the lumbar support. Push the switch rearward to decrease the lumbar support.
- Pushing upward or downward on the switch will raise and lower the position of the support.



Power Lumbar Switch

Memory Seat

The memory seat feature allows you to set two different driver seating positions (excluding lumbar position), outside mirrors, radio station preset settings and tilt/telescoping steering column position (if equipped). The memory seat buttons are located on the driver's door panel.

To set a memory position:

1. Cycle the vehicles ignition to the ON position.
2. Adjust all memory profile settings.
3. Press and release the S (SET) button.
4. Press and release the 1 or 2 button within five seconds.

NOTE:

Before programming your RKE transmitters you must select the "Personal Settings Linked To Key Fob" feature through the Uconnect® system. Refer to "Uconnect® Settings" in "Understanding Your Instrument Panel" in the Owner's Manual on the DVD for further details.



Memory Seat Buttons

To program a Key Fob to the memory position:

1. Cycle the vehicles ignition to the OFF position.
2. Select the desired memory profile 1 or 2.
3. Once the profile has been recalled, press and release the SET (S) button on the memory switch.
4. Within five seconds, press and release button (1) or (2) accordingly. "Memory Profile Set" (1 or 2) will display in the instrument cluster.
5. Press and release the LOCK button on the RKE transmitter within 10 seconds.

NOTE:

To recall the saved positions, press 1 or 2 on the memory switch or press UNLOCK on the programmed RKE transmitter.

Easy Entry/Exit Feature

The memory seat has an Easy Entry/Exit feature. This feature provides automatic driver seat positioning to enhance driver mobility when entering and exiting the vehicle.

NOTE:

The Easy Entry/Exit feature is not enabled when the vehicle is delivered from the factory. To enable (or later disable) this feature you must select "Easy Exit Seats" in "Engine Off Options" through the programmable features in the Uconnect® system.

- Refer to "Uconnect® Customer Programmable Features" in "Electronics" of this User Guide.
- For further details refer to "Uconnect® Settings" in "Understanding Your Instrument Panel" in the Owner's Manual on the DVD.

Manual Seat Adjustment

Forward/Rearward

- Lift up on the adjusting bar located at the front of the seat near the floor and release it when the seat is at the desired position. Then, using body pressure, move forward and backward on the seat to be sure that the seat adjusters have latched.



Adjusting Bar Location

GETTING STARTED

Recliner

- Lift the rear lever located on the out-board side of the seat, lean back and release when seat is in desired position.



Recliner Lever Location

Fold-Flat Front Passenger Seat

The front passenger seat can be folded flat to allow for extended cargo space.

- Pull up on the recliner lever and fold the seatback forward and down to a flat position.

CAUTION!

Do not place any article under a power seat or impede its ability to move as it may cause damage to the seat controls. Seat travel may become limited if movement is stopped by an obstruction in the seat's path.

WARNING!

- Adjusting a seat while the vehicle is moving is dangerous. The sudden movement of the seat could cause you to lose control. The seat belt might not be properly adjusted, and you could be severely injured or killed. Only adjust a seat while the vehicle is parked.
- Do not ride with the seatback reclined so that the seat belt is no longer resting against your chest. In a collision, you could slide under the seat belt and be severely injured or killed. Use the recliner only when the vehicle is parked.

REAR SEATS

60/40 Split Rear Seat

The left or right side of the second row seatback can be folded flat to carry cargo. The left and right side of the second row seat can also be tumbled forward to allow access to the third row seat.

Fold And Tumble

- Pull upward on the release lever to release the seat.

NOTE:

Also, pulling upward on this handle allows the outboard seating positions to be reclined.

- Tumble the seat forward using the red pull strap located behind the seatback.

NOTE:

If sitting in the third row seat, pull rearward on the tumble pull strap located at the rear of the seat and tumble the seat forward.



Seat Release Lever

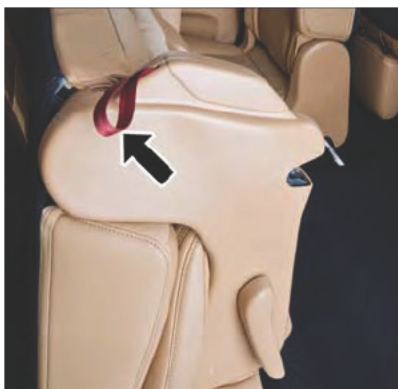

Tumble Pull Strap

GETTING STARTED

Rear Captain Chairs

Fold And Tumble

The left or right side of the second row seat-back can be folded flat to carry cargo. When the lower storage compartment is accessed using the rear push button it allows the armrest to flip forward for “fold flat mode”.

Fold flat mode allows the console armrest to be lowered below fold flat seat plane and protect the armrest vinyl from damage when using the vehicle to haul cargo.

The left and right side of the second row seat can also be tumbled forward to allow access to the third row seat. Pull upward on the release lever to release the seat. Pulling upward on this handle allows the outboard seating positions to be reclined.

- Tumble the seat forward using the red pull strap located behind the seatback.

NOTE:

If sitting in the third row seat, pull rearward on the tumble pull strap located at the rear of the seat and tumble the seat forward.

If your vehicle is equipped with a mini console there is a stepping pad to allow passengers to easily access the third row seats.



Rear Captain Chairs

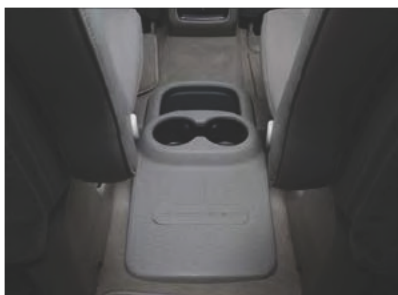

Stepping Pad Location

50/50 Third Row Folding Seat

Either or both third row seats can be folded forward to increase the rear cargo storage area.

After opening the liftgate, either seat can be folded flat by pulling up the release handle on the back of the seat.

A seat that is folded flat can be returned to the upright position by using the pull strap located on the back of the seat next to the release handle.

NOTE:

The second row seats must be in their full upright position, or tumbled when folding the third row seats.

- To raise the seat, pull the seat toward you using the strap located on the back of the seat.

WARNING!

Do not drive the vehicle with the second row seats in the tumbled position. The second row seats are only intended to be tumbled for entry and exit to the third row seat. Failure to follow these instructions could result in personal injury.

HEATED/VENTILATED SEATS

Heated Seats

On some models, the front and rear seats may be equipped with heaters in both the seat cushions and seatbacks.

The front driver and passenger heated seats are operated using the Uconnect® System.



WARNING!

- Persons who are unable to feel pain to the skin because of advanced age, chronic illness, diabetes, spinal cord injury, medication, alcohol use, exhaustion or other physical condition must exercise care when using the seat heater. It may cause burns even at low temperatures, especially if used for long periods of time.
- Do not place anything on the seat or seatback that insulates against heat, such as a blanket or cushion. This may cause the seat heater to overheat. Sitting in a seat that has been overheated could cause serious burns due to the increased surface temperature of the seat.

Front Heated Seats

The front heated seats control buttons are located within the climate or controls screen of the touchscreen.

You can choose from HI, LO or OFF heat settings. The indicator lights in each switch indicate the level of heat in use. Two indicator lights will illuminate for HI, one for LO and none for OFF.

- Press the heated seat button  once to turn the HI setting ON.
- Press the heated seat button  a second time to turn the LO setting ON.
- Press the heated seat button  a third time to turn the heating elements OFF.

GETTING STARTED

If the HI-level setting is selected, the system will automatically switch to LO-level after approximately 60 minutes of continuous operation. At that time, the display will change from HI to LO, indicating the change. The LO-level setting will turn OFF automatically after approximately 45 minutes.

NOTE:

- Once a heat setting is selected, heat will be felt within two to five minutes.
- The engine must be running for the heated seats to operate.

Vehicles Equipped With Remote Start



On models that are equipped with remote start, the heated seats can be programmed to come on during a remote start.

This feature can be programmed through the Uconnect® system. Refer to “Uconnect® Settings” in “Understanding Your Instrument Panel” in the Owner’s Manual on the DVD.

Rear Heated Seats

On some models, the two outboard seats are equipped with heated seats. The heated seat switches for these seats are located on the rear of the center console. There are two heated seat switches  that allow the rear passengers to operate the seats independently.

You can choose from HI, LO or OFF heat settings. The indicator lights in each switch indicate the level of heat in use. Two indicator lights will illuminate for HI, one for LO and none for OFF.

- Press the heated seat button  once to select HI-level heating.
- Press the heated seat button  a second time to select LO-level heating.
- Press the heated seat button  a third time to turn the heating elements OFF.

NOTE:



- Once a heat setting is selected, heat will be felt within two to five minutes.
- The engine must be running for the heated seats to operate.

When the HI-level setting is selected, the heater will provide a boosted heat level during the first four minutes of operation. Then, the heat output will drop to the normal HI-level. If the HI-level setting is selected, the system will automatically switch to LO-level after approximately 60 minutes of continuous operation. At that time, the number of illuminated LEDs changes from two to one, indicating the change. The LO-level setting will turn OFF automatically after approximately 45 minutes.

Front Ventilated Seats

Located in the seat cushion and seat back are small fans that draw the air from the passenger compartment and move air through fine perforations in the seat cover to help keep the driver and front passenger cooler in higher ambient temperatures. The fans operate at two speeds, HI and LO.

The front ventilated seats control buttons are located within the Uconnect® system. You can gain access to the control buttons through the climate screen or the controls screen.

- Press the ventilated seat button  once to choose HI.
- Press the ventilated seat button  a second time to choose LO.
- Press the ventilated seat button  a third time to turn the ventilated seat OFF.

NOTE:

The engine must be running for the ventilated seats to operate.

Vehicles Equipped With Remote Start



On models that are equipped with remote start, the ventilated seats can be programmed to come on during a remote start.

This feature can be programmed through the Uconnect® system. Refer to “Uconnect® Settings” in “Understanding Your Instrument Panel” in the Owner’s Manual on the DVD.

HEATED STEERING WHEEL

The steering wheel contains a heating element that heats the steering wheel to one temperature setting.

The heated steering wheel control button is located within the Uconnect® system. You can gain access to the control buttons through the climate screen or the controls screen.

- Press the heated steering wheel button  once to turn the heating element ON.
- Press the heated steering wheel button  a second time to turn the heating element OFF.

Once the heated steering wheel has been turned on, it will operate for up to 80 minutes before automatically shutting off. The heated steering wheel can shut off early or may not turn on when the steering wheel is already warm.

NOTE:

Vehicle Equipped With Remote Start

On models that are equipped with remote start, this feature can be programmed to come on during a remote start through the Uconnect® system. Refer to “Uconnect® Settings” in “Understanding Your Instrument Panel” in the Owner’s Manual on the DVD.

WARNING!

- Persons who are unable to feel pain to the skin because of advanced age, chronic illness, diabetes, spinal cord injury, medication, alcohol use, exhaustion, or other physical conditions must exercise care when using the steering wheel heater. It may cause burns even at low temperatures, especially if used for long periods.
- Do not place anything on the steering wheel that insulates against heat, such as a blanket or steering wheel covers of any type and material. This may cause the steering wheel heater to overheat.

GETTING STARTED

TILT/TELESCOPING STEERING COLUMN

Manual Tilt/Telescoping Steering Column

The tilt/telescoping control handle is located below the steering wheel at the end of the steering column.

- Push the handle down to unlock the steering column.
- To tilt the steering column, move the steering wheel upward or downward as desired.
- To lengthen or shorten the steering column, pull the steering wheel outward or push it inward as desired.
- Pull up on the handle to lock the column firmly in place.



Manual Tilt/Telescoping Steering Column Handle

Power Tilt/Telescoping Steering Column

The power tilt/telescoping steering control is located below the turn signal/wiper/washer/high beam lever on the steering column.

- To tilt the steering column, move the power tilt/telescoping control up or down as desired.
- To lengthen or shorten the steering column, pull the control toward you or push the control away from you as desired.

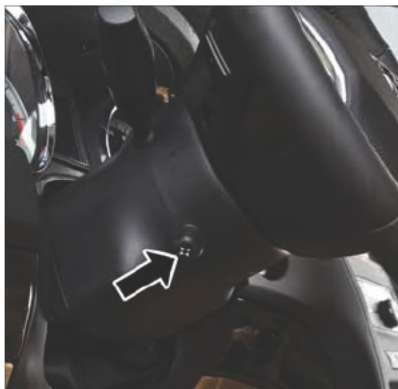

Power Tilt/Telescoping Steering Control Location

WARNING!

- Do not adjust the steering wheel while driving. The tilt/telescoping adjustment must be locked while driving. Adjusting the steering wheel while driving or driving without the tilt/telescoping adjustment locked could cause the driver to lose control of the vehicle. Failure to follow this warning may result in you and others being severely injured or killed.
- Moving the steering column while the vehicle is moving is dangerous. Without a stable steering column, you could lose control of the vehicle and have a collision. Adjust the column only while the vehicle is stopped.

OPERATING YOUR VEHICLE

ENGINE BREAK-IN RECOMMENDATIONS

A long break-in period is not required for the engine and drivetrain (transmission and axle) in your vehicle.

Drive moderately during the first 300 miles (500 km). After the initial 60 miles (100 km), speeds up to 50 or 55 mph (80 or 90 km/h) are desirable.

While cruising, brief full-throttle acceleration within the limits of local traffic laws contributes to a good break-in. Wide-open throttle acceleration in low gear can be detrimental and should be avoided.

The engine oil installed in the engine at the factory is a high-quality energy conserving type lubricant. Oil changes should be consistent with anticipated climate conditions under which vehicle operations will occur. For the recommended viscosity and quality grades, refer to "Maintaining Your Vehicle."

NOTE:

A new engine may consume some oil during its first few thousand miles (kilometers) of operation. This should be considered a normal part of the break-in and not interpreted as an indication of an engine problem or malfunction.

CAUTION!

Never use Non-Detergent Oil or Straight Mineral Oil in the engine or damage may result.

TURN SIGNAL/WIPER/WASHER/HIGH BEAM LEVER

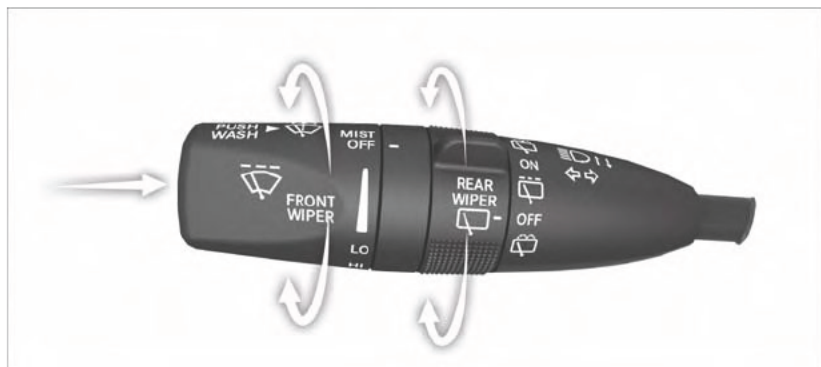

Multifunction Lever

Turn Signal/Lane Change Assist

Tap the lever up or down once and the turn signal (right or left) will flash three times and automatically turn off.

Front Wipers

Intermittent, Low And High Operation

Rotate the end of the lever to one of the first four detent positions for intermittent settings, the fifth detent for low wiper operation and the sixth detent for high wiper operation.

Washer Operation

Push inward on the end of the lever and hold for as long as spray is desired.

Mist

Rotate the end of the lever downward when a single wipe is desired.

NOTE:

The mist feature does not activate the washer pump; therefore, no washer fluid will be sprayed on the windshield. The wash function must be activated in order to spray the windshield with washer fluid.

Rain Sensing Wipers

This feature senses moisture on the vehicle's windshield and automatically activates the wipers for the driver when the switch is in the intermittent position. Rotate the end of the lever to one of four settings to activate this feature and adjust sensitivity.

The Rain Sensing feature can be turned on and off using the Uconnect® System. Refer to the "Programmable Features" in the "Electronics" section in this guide.

Refer to the Owner's Manual on the DVD for further details.

Rear Wiper

Rear Wiper Operation

Rotate the center portion of the lever forward to the first detent for intermittent operation and to the second detent for rear wiper operation.

Rear Washer Operation

Rotate the center portion of the lever past the second detent to activate the rear washer.

High Beam Operation

Push the lever forward to activate the high beams. Pull the lever toward you for flash to pass.



NOTE:

For safe driving, turn off high beams when oncoming traffic is present to prevent headlight glare and as a courtesy to other motorists.

OPERATING YOUR VEHICLE

HEADLIGHT SWITCH

Automatic Headlights/Parking Lights/Headlights

- Rotate the headlight switch, located on the instrument panel to the left of the steering wheel, to the first detent for parking lights  and to the second detent for headlights .
- With the parking lights or low beam headlights on, push the headlight switch once for fog lights.
- Rotate the headlight switch to “AUTO” for AUTO headlights.
- When set to AUTO, the system automatically turns the headlights on or off based on ambient light levels.



Headlight Switch

- 1 — Auto
- 2 — Rotate Headlight Switch
- 3 — Push Fog Light
- 4 — Rotate Dimmer

Automatic High Beams

The Automatic High Beams system provides increased forward lighting at night by automating high beam control through the use of a digital camera mounted above the inside rearview mirror. This camera detects vehicle specific light and automatically

switches from high beams to low beams until the approaching vehicle is out of view. This feature is programmable through the Uconnect® system. Refer to “Uconnect® Settings” in “Understanding Your Instrument Panel” in the Owner’s Manual on the DVD for further details.

Instrument Panel Dimmer

- Rotate the dimmer control to the extreme bottom position to fully dim the instrument panel lights and prevent the interior lights from illuminating when a door is opened.
- Rotate the dimmer control up to increase the brightness of the instrument panel when the parking lights or headlights are on.
- Rotate the dimmer control up to the next detent position to fully brighten the odometer and radio when the parking lights or headlights are on.
- Rotate the dimmer control up to the last detent position to turn on the interior lighting.

If your vehicle is equipped with a touchscreen, the dimming is programmable through the Uconnect® system. Refer to “Uconnect® Settings” in “Understanding Your Instrument Panel” in the Owner’s Manual on the DVD for further details.

ELECTRONIC SPEED CONTROL

The Electronic Speed Control switches are located on the right side of the steering wheel.

Cruise ON/OFF

- Push the ON/OFF button  to activate the Electronic Speed Control.

CRUISE CONTROL READY will appear in the Driver Information Display (DID) to indicate the Electronic Speed Control is on.

- Push the ON/OFF button  a second time to turn the system off.

CRUISE CONTROL OFF will appear in the Driver Information Display (DID) to indicate the Electronic Speed Control is off.

SET

- With the Electronic Speed Control on, push and release the SET+ or SET- button to set a desired speed.

Once a speed has been set a message CRUISE CONTROL SET TO MPH/KM will appear indicating what speed was set. An indicator CRUISE will also appear and stay on in the Driver Information Display (DID) when the speed is set.

Accel/Decel

To Increase Speed

- When the Electronic Speed Control is set, you can increase speed by pushing the SET + button.

The drivers preferred units can be selected through the instrument panel settings if equipped. Refer to "Understanding Your Instrument Panel" in the Owner's Manual on the DVD for more information. The speed increment shown is dependant on the speed of U.S. (mph) or Metric (km/h) units:

U.S. Speed (mph)

- Pressing the SET + button once will result in a 1 mph increase in set speed. Each subsequent tap of the button results in an increase of 1 mph.
- If the button is continually pressed, the set speed will continue to increase until the button is released, then the new set speed will be established.



Electronic Speed Control Switches

- 1 — Push Cancel
- 2 — Push Set+/Accel
- 3 — Push Resume
- 4 — Push On/Off
- 5 — Push Set-/Decel

OPERATING YOUR VEHICLE

Metric Speed (km/h)

- Pressing the SET + button once will result in a 1 km/h increase in set speed. Each subsequent tap of the button results in an increase of 1 km/h.
- If the button is continually pressed, the set speed will continue to increase until the button is released, then the new set speed will be established.

To Decrease Speed

- When the Electronic Speed Control is set, you can decrease speed by pushing the SET - button.

The drivers preferred units can be selected through the instrument panel settings if equipped. Refer to "Understanding Your Instrument Panel" in the Owner's Manual on the DVD for more information. The speed decrement shown is dependant on the speed of U.S. (mph) or Metric (km/h) units:

U.S. Speed (mph)

- Pressing the SET - button once will result in a 1 mph decrease in set speed. Each subsequent tap of the button results in a decrease of 1 mph.
- If the button is continually pressed, the set speed will continue to decrease until the button is released, then the new set speed will be established.

Metric Speed (km/h)

- Pressing the SET - button once will result in a 1 km/h decrease in set speed. Each subsequent tap of the button results in a decrease of 1 km/h.
- If the button is continually pressed, the set speed will continue to decrease until the button is released, then the new set speed will be established.

Resume

- To resume a previously selected set speed in memory, push the RES button and release.

Cancel

- Push the CANCEL button, or apply the brakes to cancel the set speed and maintain the set speed memory.
- Push the ON/OFF button to turn the system off and erase the set speed memory.

WARNING!

Leaving the Electronic Speed Control system on when not in use is dangerous. You could accidentally set the system or cause it to go faster than you want. You could lose control and have an accident. Always leave the system OFF when you are not using it.

ADAPTIVE CRUISE CONTROL (ACC)

If your vehicle is equipped with adaptive cruise control the controls operate exactly the same as the electronic speed control with only a couple of differences. With this option you can set a specified distance you would like to maintain between you and the vehicle in front of you.

If the ACC sensor detects a vehicle ahead, ACC will apply limited braking or acceleration automatically to maintain a preset following distance, while matching the speed of the vehicle ahead.

If the sensor does not detect a vehicle ahead of you, ACC will maintain a fixed set speed.



Adaptive Cruise Switches

- 1 — Adaptive Cruise Control (ACC) On/Off
- 2 — Distance Setting – Decrease
- 3 — Distance Setting – Increase

ACC ON/OFF

- Push and release the Adaptive Cruise Control (ACC) ON/OFF button.

ACC READY will appear in the Driver Information Display (DID) to indicate the ACC is on.

- Push and release the Adaptive Cruise Control (ACC) ON/OFF button a second time to turn the system off.

Adaptive Cruise Control (ACC) Off will appear in the Driver Information Display (DID) to indicate the ACC is off.

To Vary The Speed Setting

To Increase Speed

While ACC is set, you can increase the set speed by pressing the SET + button.

The drivers preferred units can be selected through the instrument panel settings if equipped. Refer to “Understanding Your Instrument Panel” in the Owner’s Manual on the DVD for more information. The speed increment shown is dependant on the speed of U.S. (mph) or Metric (km/h) units:

U.S. Speed (mph)

- Pressing the SET + button once will result in a 1 mph increase in set speed. Each subsequent tap of the button results in an increase of 1 mph.
- If the button is continually pressed, the set speed will continue to increase in 5 mph increments until the button is released. The increase in set speed is reflected in the DID.

OPERATING YOUR VEHICLE

Metric Speed (km/h)

- Pressing the SET + button once will result in a 1 km/h increase in set speed. Each subsequent tap of the button results in an increase of 1 km/h.
- If the button is continually pressed, the set speed will continue to increase in 10 km/h increments until the button is released. The increase in set speed is reflected in the DID.

To Decrease Speed

While ACC is set, the set speed can be decreased by pressing the SET - button.

The driver's preferred units can be selected through the instrument panel settings if equipped. Refer to "Understanding Your Instrument Panel" in the Owner's Manual on the DVD for more information. The speed increment shown is dependent on the speed of U.S. (mph) or Metric (km/h) units:

U.S. Speed (mph)

- Pressing the SET - button once will result in a 1 mph decrease in set speed. Each subsequent tap of the button results in a decrease of 1 mph.
- If the button is continually pressed, the set speed will continue to decrease in 5 mph decrements until the button is released. The decrease in set speed is reflected in the DID.

Metric Speed (km/h)

- Pressing the SET - button once will result in a 1 km/h decrease in set speed. Each subsequent tap of the button results in a decrease of 1 km/h.
- If the button is continually pressed, the set speed will continue to decrease in 10 km/h decrements until the button is released. The decrease in set speed is reflected in the DID.

NOTE:

- When you override and push the SET + button or SET - buttons, the new Set Speed will be the current speed of the vehicle.
- When you use the SET - button to decelerate, if the engine's braking power does not slow the vehicle sufficiently to reach the set speed, the brake system will automatically slow the vehicle.
- The ACC system applies the brake down to a full stop when following a target vehicle. If an ACC host vehicle follows a target vehicle to a standstill, the host vehicle will release the vehicle brakes two seconds after coming to a full stop.
- The ACC system maintains set speed when driving up hill and down hill. However, a slight speed change on moderate hills is normal. In addition, downshifting may occur while climbing uphill or descending downhill. This is normal operation and necessary to maintain set speed. When driving up hill and down hill, the ACC system will cancel if the braking temperature exceeds normal range (overheated).

Distance Setting (ACC Only)

The specified following distance for ACC can be set by varying the distance setting between four bars (longest), three bars (long), two bars (medium) and one bar (short). Using this distance setting and the vehicle speed, ACC calculates and sets the distance to the vehicle ahead. This distance setting displays in the DID.

- To increase the distance setting, press the Distance Setting—Increase button and release. Each time the button is pressed, the distance setting increases by one bar (longer).
- To decrease the distance setting, press the Distance Setting—Decrease button and release. Each time the button is pressed, the distance setting decreases by one bar (shorter).

ACC Operation At Stop

If the ACC system brings your vehicle to a standstill while following a target vehicle, if the target vehicle starts moving within two seconds of your vehicle coming to a standstill, your vehicle will resume motion without the need for any driver action.

If the target vehicle does not start moving within two seconds of your vehicle coming to a standstill, the driver will either have to press the RES (resume) button, or apply the accelerator pedal to reengage the ACC to the existing Set Speed.

While the ACC system is holding your vehicle at a standstill, if the driver seatbelt is unbuckled or the driver door is opened, the parking brake will be activated, and the ACC system will be cancelled.

Changing Modes (ACC Only)

If desired, the Adaptive Cruise Control mode can be turned off and the system can be operated as a normal (Fixed Speed) Speed Control mode. When in the normal (Fixed Speed) Speed Control mode the distance setting feature will be disabled and the system will maintain the speed you set.

- To change between the different cruise control modes, press the ADAPTIVE CRUISE CONTROL (ACC) ON/OFF button which turns the ACC and the normal (Fixed Speed) Speed Control OFF.
- Pressing the normal (Fixed Speed) SPEED CONTROL ON/OFF button will result in turning ON (changing to) the normal (Fixed Speed) Speed Control mode.

Refer to your Owner's Manual on the DVD for further information.

OPERATING YOUR VEHICLE

WARNING!

Adaptive Cruise Control (ACC) is a convenience system. It is not a substitute for active driving involvement. It is always the driver's responsibility to be attentive of road, traffic, and weather conditions, vehicle speed, distance to the vehicle ahead; and, most importantly, brake operation to ensure safe operation of the vehicle under all road conditions. Your complete attention is always required while driving to maintain safe control of your vehicle. Failure to follow these warnings can result in a collision and death or serious personal injury.

The ACC system:

- Does not react to pedestrians, oncoming vehicles, and stationary objects (e.g., a stopped vehicle in a traffic jam or a disabled vehicle).
- Cannot take street, traffic, and weather conditions into account, and may be limited upon adverse sight distance conditions.
- Does not always fully recognize complex driving conditions, which can result in wrong or missing distance warnings.
- Will bring the vehicle to a complete stop while following a target vehicle and hold the vehicle for 2 seconds in the stop position. If the target vehicle does not start moving within two seconds the ACC system will display a message that the system will release the brakes and that the brakes must be applied manually. An audible chime will sound when the brakes are released.

You should switch off the ACC system:

- When driving in fog, heavy rain, heavy snow, sleet, heavy traffic, and complex driving situations (i.e., in highway construction zones).
- When entering a turn lane or highway off ramp; when driving on roads that are winding, icy, snow-covered, slippery, or have steep uphill or downhill slopes.
- When towing a trailer up or down steep slopes.
- When circumstances do not allow safe driving at a constant speed.

The Cruise Control system has two control modes:

- Adaptive Cruise Control mode for maintaining an appropriate distance between vehicles.
- Normal (fixed speed) electronic speed control mode for cruising at a constant preset speed. For additional information, refer to "Normal (Fixed Speed) Cruise Control Mode" in this section.

Normal (fixed speed) electronic speed control will not react to preceding vehicles. Always be aware of the mode selected.

You can change the mode by using the Cruise Control buttons. The two control modes function differently. Always confirm which mode is selected.

FORWARD COLLISION WARNING (FCW) WITH MITIGATION

The Forward Collision Warning (FCW) system with mitigation provides the driver with audible warnings, visual warnings within the DID, and may apply a brake jerk to warn the driver when it detects a potential frontal collision. The warnings and limited braking are intended to provide the driver with enough time to react, avoid or mitigate the potential collision.

NOTE:

FCW monitors the information from the forward looking sensors as well as the Electronic Brake Controller (EBC), to calculate the probability of a forward collision. When the system determines that a forward collision is probable, the driver will be provided with audible and visual warnings and may provide a brake jerk warning. If the driver does not take action based upon these progressive warnings, then the system will provide a limited level of active braking to help slow the vehicle and mitigate the potential forward collision. If the driver reacts to the warnings by braking and the system determines that the driver intends to avoid the collision by braking but has not applied sufficient brake force, the system will compensate and provide additional brake force as required.

Turning FCW ON Or OFF

NOTE:

The default status of FCW is “On”, this allows the system to warn you of a possible collision with the vehicle in front of you when you are farther away and it applies limited braking. This gives you the most reaction time to avoid a possible collision.

The forward collision button is on the switch panel that is located in the center of the instrument panel.

- To turn the FCW system OFF, press the forward collision button once (LED turns on).
- To turn the FCW system back ON, press the forward collision button again (LED turns off).

Changing FCW Status

The FCW feature has two settings and can be changed within the Uconnect® System Screen:

- Far
- Near

NOTE:

The FCW and active braking settings can only be changed when the vehicle is in PARK.

OPERATING YOUR VEHICLE

Far

The default status of FCW is the “Far” setting.

The far setting provides warnings for potential collisions more distant in front of the vehicle, allowing the driver to have the most reaction time to avoid a collision.

This setting is designed to provide early warnings per NHTSA (National Highway Traffic Safety Administration) recommendations.

More cautious drivers that do not mind frequent warnings may prefer this setting.

NOTE:

This setting gives you the most reaction time.

Near

Changing the FCW status to the “Near” setting, allows the system to warn you of a potential frontal collision when you are much closer.

This setting provides less reaction time than the “Far” setting, which allows for a more dynamic driving experience.

More dynamic or aggressive drivers that want to avoid frequent warnings may prefer this setting.

Off

Changing the FCW status to “Off” prevents the system from warning you of a possible collision with the vehicle in front of you.

Turning Active Braking ON Or OFF

The Active Braking feature has two settings and can be changed within the Uconnect® System Screen:

- On
- Off

Changing the Active Braking status to “Off” prevents the system from providing limited autonomous braking, or additional brake support if the driver is not braking adequately in the event of a potential frontal collision.

NOTE:

If FCW is set to “Off”, “FCW OFF” will be displayed in the DID.

Refer to the Owner's Manual on the DVD for further details.

WARNING!

Forward Collision Warning (FCW) is not intended to avoid a collision on its own, nor can FCW detect every type of potential collision. The driver has the responsibility to avoid a collision by controlling the vehicle via braking and steering. Failure to follow this warning could lead to serious injury or death.

AUTOMATIC DIMMING MIRRORS

The rearview and driver side exterior mirror automatically adjusts for headlight glare from vehicles behind you.

You can turn the feature on or off when the Automatic Dimming Mirror feature is selected through the programmable features in the Uconnect® system. Refer to “Uconnect® Settings” in “Understanding Your Instrument Panel” in the Owner’s Manual on the DVD for further details.

ELECTRONIC SHIFTER

Your vehicle is equipped with a fuel efficient eight-speed transmission. The Electronic gear selector is located on the center console. The transmission gear (PRND) is displayed both above the shifter control and in the Electronic Vehicle Information Center (EVIC).

- To select a gear range, simply rotate the shifter control.

NOTE:

You must press the brake pedal to shift the transmission out of PARK or from NEUTRAL into DRIVE or REVERSE.

- To shift past multiple gear ranges at once (such as PARK to DRIVE), simply rotate the switch to the appropriate detent.
- Select the DRIVE range for normal driving.



Electronic Gear Selector

OPERATING YOUR VEHICLE

WARNING!

- Never use the PARK position as a substitute for the parking brake. Always apply the parking brake fully when parked to guard against vehicle movement and possible injury or damage.
- Your vehicle could move and injure you and others if it is not in PARK. Make sure the transmission is in PARK before leaving the vehicle.
- It is dangerous to shift out of PARK or NEUTRAL if the engine speed is higher than idle speed. If your foot is not firmly pressing the brake pedal, the vehicle could accelerate quickly forward or in reverse. You could lose control of the vehicle and hit someone or something. Only shift into gear when the engine is idling normally and your foot is firmly pressing the brake pedal.
- Unintended movement of a vehicle could injure those in or near the vehicle. As with all vehicles, you should never exit a vehicle while the engine is running. Before exiting a vehicle, always apply the parking brake, shift the transmission into PARK, turn the engine OFF, and remove the key fob. When the ignition is in the OFF position, the transmission is locked in PARK, securing the vehicle against unwanted movement.
- When leaving the vehicle, always make sure the ignition is in the OFF position, remove the key fob from the vehicle, and lock the vehicle.
- Never leave children alone in a vehicle, or with access to an unlocked vehicle. Allowing children to be in a vehicle unattended is dangerous for a number of reasons. A child or others could be seriously or fatally injured. Children should be warned not to touch the parking brake, brake pedal or the transmission gear selector.
- Do not leave the key fob in or near the vehicle (or in a location accessible to children), and do not leave the ignition in the ACC or ON/RUN position. A child could operate power windows, other controls, or move the vehicle.

AUTOSTICK

AutoStick is a driver-interactive transmission feature providing manual shift control, giving you more control of the vehicle. AutoStick allows you to maximize engine braking, eliminate undesirable upshifts and downshifts, and improve overall vehicle performance. This system can also provide you with more control during passing, city driving, cold slippery conditions, mountain driving, trailer towing, and many other situations.



AutoStick Shift Paddles

Operation

When the transmission is in DRIVE, it will operate automatically, shifting between the eight available gears. To engage AutoStick, simply tap one of the steering wheel-mounted shift paddles (+/-). Tapping (-) to enter AutoStick will downshift the transmission to the next lower gear, while using (+) to enter AutoStick will retain the current gear. When AutoStick is active, the current transmission gear is displayed in the instrument cluster.

In AutoStick mode, the transmission will shift up or down when (+/-) is manually selected by the driver, unless an engine lugging or overspeed condition would result. It will remain in the selected gear until another upshift or downshift is chosen, except as described below.

- The transmission will automatically downshift as the vehicle slows (to prevent engine lugging) and will display the current gear.
- The transmission will automatically downshift to first gear when coming to a stop. After a stop, the driver should manually upshift (+) the transmission as the vehicle is accelerated.
- You can start out, from a stop, in first or second gear. Tapping (+) at a stop will allow starting in second gear. Starting out in second gear can be helpful in snowy or icy conditions.
- If a requested downshift would cause the engine to over-speed, that shift will not occur.
- The system will ignore attempts to upshift at too low of a vehicle speed.
- Holding the (-) paddle depressed will downshift the transmission to the lowest gear possible at the current speed.
- Transmission shifting will be more noticeable when AutoStick is engaged.
- The system may revert to automatic shift mode if a fault or overheat condition is detected.

To disengage AutoStick mode, press and hold the (+) shift paddle until "D" is once again indicated in the instrument cluster. You can shift in or out of AutoStick mode at any time without taking your foot off the accelerator pedal.

WARNING!

Do not downshift for additional engine braking on a slippery surface. The drive wheels could lose their grip and the vehicle could skid, causing a collision or personal injury.

OPERATING YOUR VEHICLE

FUEL ECONOMY (ECO) MODE

The Fuel Economy (ECO) mode can improve the vehicle's overall fuel economy during normal driving conditions. Each time the vehicle is started ECO mode is engaged and an amber light in the center stack of the instrument panel will be illuminated. To disable ECO mode, press the "ECO" switch in the center stack of the instrument panel and the amber light will go out indicating ECO mode is disabled.

When the Fuel Economy (ECO) Mode is engaged, the vehicle control systems will change the following:

- The transmission will upshift sooner and downshift later.
- The overall driving performance will be more conservative.
- Some ECO mode functions may be temporarily inhibited based on temperature and other factors.



ECO Switch

AUTOMATIC CLIMATE CONTROLS

Uconnect® 5.0 Touchscreen Automatic Climate Controls

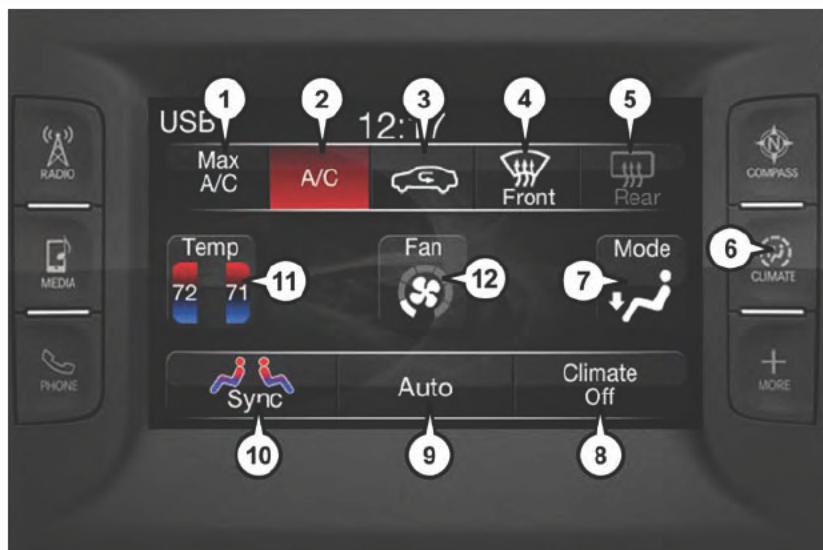

Uconnect® 5.0 Automatic Climate Controls

- | | |
|------------------------------|---------------------------------|
| 1 — Max A/C Button | 7 — Mode Control Button |
| 2 — A/C Button | 8 — Off Button |
| 3 — Air Recirculation Button | 9 — Auto Button |
| 4 — Front Defroster Button | 10 — Sync Button |
| 5 — Rear Defroster Button | 11 — Temperature Control Button |
| 6 — Climate Control Button | 12 — Blower Control Button |

OPERATING YOUR VEHICLE

Uconnect® 8.4 Touchscreen Automatic Climate Controls



Uconnect® 8.4 Automatic Climate Controls

- | | |
|------------------------------|--------------------------------|
| 1 — MAX A/C Button | 9 — Passenger Temperature Down |
| 2 — A/C Button | 10 — SYNC Button |
| 3 — Air Recirculation Button | 11 — Blower Control Buttons |
| 4 — AUTO Button | 12 — Mode Control Buttons |
| 5 — FRONT Defroster Button | 13 — OFF Button |
| 6 — REAR Defroster Button | 14 — Driver Temperature Down |
| 7 — REAR Climate Button | 15 — Driver Temperature Up |
| 8 — Passenger Temperature Up | |

OPERATING YOUR VEHICLE

Climate Control Knobs



Automatic Climate Controls

- | | |
|------------------------------|--------------------------------|
| 1 — Driver Temperature Up | 7 — Passenger Temperature Down |
| 2 — OFF Button | 8 — AUTO Button |
| 3 — Blower Control Knob | 9 — Driver Temperature Down |
| 4 — Passenger Temperature Up | 10 — Air Recirculation Button |
| 5 — REAR Defroster Button | 11 — A/C Button |
| 6 — FRONT Defroster Button | |

Automatic Operation

- Press the AUTO button.
- Select the desired temperature by pressing the Temperature Control buttons.
- The system will maintain the set temperature automatically.

Air Conditioning (A/C)

- If the air conditioning button is pressed while in AUTO mode, the system will exit AUTO mode and stay in A/C. The mode and blower will be set at the closest mode and blower position that the system was operating in AUTO.

MAX A/C

- MAX A/C sets the control for maximum cooling performance.
- Press and release to toggle between MAX A/C and the prior settings. The button on the touchscreen illuminates when MAX A/C is ON.
- In MAX A/C, the blower level and mode position can be adjusted to desired user settings. Pressing other settings will cause the MAX A/C operation to switch to the prior settings and the MAX A/C indicator will turn off.

OPERATING YOUR VEHICLE

SYNC Temperature Button

- Press the “SYNC” button on the Uconnect® radio touchscreen to control the driver and passenger temperatures simultaneously. Press the “SYNC” button on the touchscreen a second time to control the temperatures individually.

Air Recirculation

- Use Recirculation for maximum A/C operation.
- For window defogging, turn the Recirculation button off.
- If the Recirculation button is pressed while in front defrost mode, the indicator will flash three times to indicate that recirculation state is not allowed in front defrost mode.

Heated Mirrors

The mirrors are heated to melt frost or ice. This feature is activated whenever you turn on the rear window defroster.

Rear Temperature Controls



Rear Automatic Temperature Control

- 1 — Rear Blower Control AUTO Mode
- 2 — Rotate Blower Control
- 3 — Rotate Temperature Control
- 4 — Rotate Mode Control

The rear controls for the ATC System are located in the headliner, near the center of the vehicle.

OPERATING YOUR VEHICLE

The rear temperature controls can be turned on two ways:

- Press the “REAR” control button on the Uconnect® front temperature control screen and adjust to the desired rear temperature.
- Rotate the Rear Temperature Control or the Rear Blower Control knobs on the rear temperature controls.
- Press the “REAR” button and then the “OFF” button on the Uconnect® front temperature control screen to turn the rear controls off.

PARKSENSE® REAR PARK ASSIST

The four ParkSense® sensors, located in the rear fascia/bumper, monitor the area behind the vehicle that is within the sensors’ field of view.

The sensors can detect obstacles from approximately 12 in (30 cm) up to 79 in (200 cm) from the rear bumper while the vehicle is in REVERSE, a warning will display in the Driver Information Display (DID) and a chime will sound (when Sound and Display is selected from the Customer Programmable Features section of the Uconnect® System screen). As the vehicle moves closer to the object, the chime rate will change from single 1/2 second tone, to slow, to fast, to continuous.

Cleaning The ParkSense® Sensors

If “PARKSENSE UNAVAILABLE WIPE REAR SENSORS” or “PARKSENSE UNAVAILABLE WIPE FRONT SENSORS” appears in the “Driver Information Display (DID)”, clean the ParkSense® sensors with water, car wash soap and a soft cloth. Do not use rough or hard cloths. Do not scratch or poke the sensors. Otherwise, you could damage the sensors.

PARKVIEW® REAR BACK-UP CAMERA

You can see an on-screen image of the rear of your vehicle whenever the shift lever/gear selector is put into REVERSE. The ParkView® Rear Back-Up Camera image will be displayed on the radio display screen, located on the center stack of the instrument panel.

If the radio display screen appears foggy, clean the camera lens located on the liftgate.

WARNING!

Drivers must be careful when backing up; even when using the ParkView® Rear Back-Up Camera. Always check carefully behind your vehicle, and be sure to check for pedestrians, animals, other vehicles, obstructions, or blind spots before backing up. You must continue to pay attention while backing up. Failure to do so can result in serious injury or death.

OPERATING YOUR VEHICLE

BLIND SPOT MONITORING

The Blind Spot Monitoring (BSM) system uses two radar-based sensors, located inside the rear bumper fascia, to detect Highway licensable vehicles (automobiles, trucks, motorcycles etc.) that enter the blind spot zones from the rear/front/side of the vehicle.

The Blind Spot Monitoring (BSM) system warning light, located in the outside mirrors, will illuminate if a vehicle moves into a blind spot zone.

The BSM system can also be configured to sound an audible (chime) alert and mute the radio to notify you of objects that have entered the detection zones.

Refer to your Owner's Manual on the DVD for further details.

POWER SUNROOF

The power sunroof switch is located on the overhead console.

Opening Sunroof

Express Open

Press the switch rearward and release it within one-half second. The sunroof will fully open and stop automatically.

Manual Open

Press and hold the switch rearward to open the sunroof. Any release of the switch will stop the movement, and the sunroof will remain in a partially open position until the switch is pressed again.

Venting Sunroof

Press and release the button and the sunroof will open to the vent position.

This is called "Express Vent" and will occur regardless of sunroof position. During Express Vent operation, any movement of the switch will stop the sunroof.



Power Sunroof Switch

- 1 — Opening Sunroof
- 2 — Venting Sunroof
- 3 — Closing Sunroof

Closing Sunroof

Express Closing

Press the switch forward and release it within one-half second. The sunroof will fully close automatically from any position.

Manual Closing

Press and hold the switch forward to close the sunroof. Any release of the switch will stop the movement, and the sunroof will remain in a partially closed position until the switch is pressed again.

Pinch Protection Feature

This feature will detect an obstruction in the opening of the sunroof during Express Close operation. If an obstruction in the path of the sunroof is detected, the sunroof will automatically retract. Remove the obstruction if this occurs. Next, press the switch forward and release to Express Close.

NOTE:

If three consecutive sunroof close attempts result in Pinch Protect reversals, the fourth close attempt will be a Manual Close movement with Pinch Protect disabled.

WARNING!

- Do not let children play with the sunroof. Never leave children unattended in a vehicle, or with access to an unlocked vehicle. Do not leave the Key Fob in or near the vehicle, and do not leave the ignition of a vehicle equipped with Keyless Enter-N-Go™ in the ACC or ON/RUN mode. Occupants, particularly unattended children, can become entrapped by the power sunroof while operating the power sunroof switch. Such entrapment may result in serious injury or death.
- In a collision, there is a greater risk of being thrown from a vehicle with an open sunroof. You could also be severely injured or killed. Always fasten your seat belt properly and make sure all passengers are properly secured.
- Do not allow small children to operate the sunroof. Never allow your fingers, other body parts, or any object to project through the sunroof opening. Injury may result.

WIND BUFFETING

Wind buffeting can be described as a helicopter-type percussion sound. If buffeting occurs with the rear windows open, adjust the front and rear windows together.

If buffeting occurs with the sunroof open, adjust the sunroof opening, or adjust any window. This will minimize buffeting.



YOUR VEHICLE'S SOUND SYSTEM

1. Uconnect® Phone Button pg. 132
2. Uconnect® Voice Command Button pg. 104
3. Phone Hang Up Button pg. 132
4. Steering Wheel Audio control (Left) pg. 142
5. Steering Wheel Audio control (Right) pg. 142
6. Volume/Mute Knob
7. Assist Button pg. 70

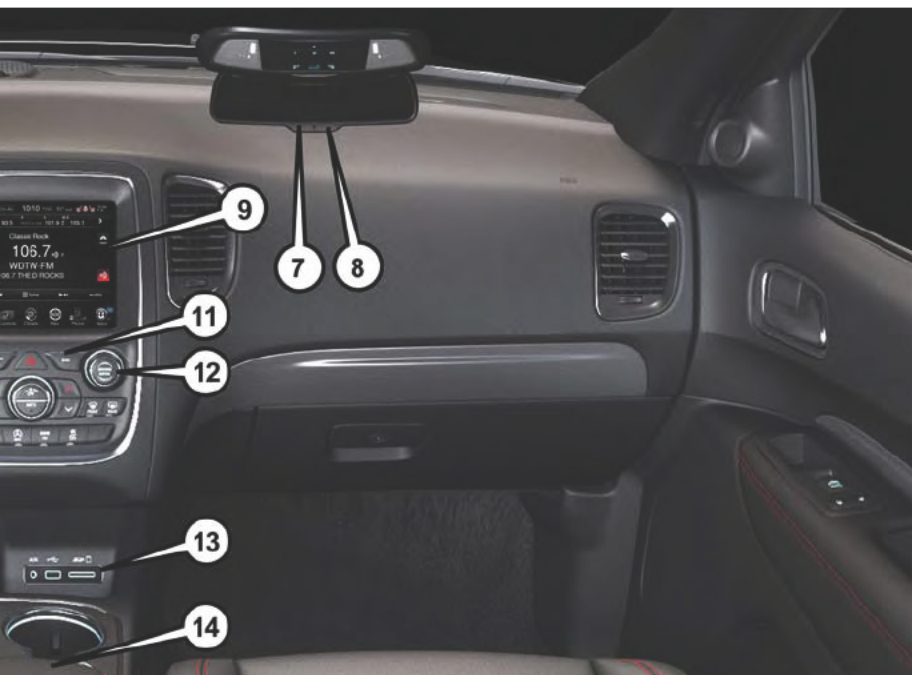

- 8. Emergency 911 Button pg. 70
- 9. Uconnect® System pg. 80
- 10. Uconnect® Radio Screen Off Button
- 11. Uconnect® Radio Back Button
- 12. Tune/Scroll Knob/Browse/Enter Button
- 13. Media Hub: AUX Audio Jack, USB Port, and SD Card Slot pg. 98
- 14. CD Player Inside Center Console pg. 82

IDENTIFYING YOUR RADIO

Uconnect® 5.0

- 5" Touchscreen
- Three buttons on the faceplate on either side of the display



Uconnect® 5.0

Uconnect® 8.4A

- 8.4" Touchscreen
- Climate button on the touchscreen in lower menu bar



Uconnect® 8.4A

Uconnect® 8.4AN

- 8.4" Touchscreen
- Climate button on the touchscreen in lower menu bar

**Uconnect® 8.4AN**

1 — Navigation Standard On 8.4AN

Uconnect® ACCESS

Uconnect® Access — If Equipped (Available On Uconnect® 8.4A/8.4AN — U.S. Residents Only)

WARNING!

ALWAYS drive safely with your hands on the steering wheel. You have full responsibility and assume all risks related to the use of the Uconnect® features and applications in this vehicle. Only use Uconnect® when it is safe to do so. Failure to do so may result in an accident involving serious injury or death.

Uconnect® Access enhances your ownership and driving experience by connecting your vehicle with a built-in cellular connection. With Uconnect® Access, you can:

- Place a call to a local 9-1-1 Operator for emergency assistance.
- Remotely lock/unlock your doors and start your vehicle from virtually anywhere, using the Uconnect® Access App from your smartphone. You can also do so by logging into Mopar Owner Connect, or by calling Uconnect® Care. (Vehicle must be within the United States and have network coverage).
- Turn your vehicle into a WiFi Hotspot and connect your devices to the internet.
- Receive text or email notifications if your vehicle's theft alarm goes off.
- Receive stolen vehicle assistance, using GPS technology to help authorities locate your vehicle if it is stolen.

- Listen to your text messages or send free-form text messages with your voice while keeping your hands on the wheel, using the Voice Texting feature. Requires a cell phone that supports Bluetooth Message Access Profile (MAP).
- Search for places to eat, shop, relax and play with Yelp®, using your voice or on-screen menu. Then navigate to them (navigation standard on Uconnect® 8.4AN, optional on Uconnect® 8.4A).
- Get operator assistance using the ASSIST button on your interior rearview mirror.

Before you drive, familiarize yourself with the easy-to-use Uconnect® Access.

1. The ASSIST and 9-1-1 buttons are located on your rearview mirror. The ASSIST button is used for contacting Roadside Assistance, Vehicle Care and Uconnect® Care. The 9-1-1 button connects you to emergency services.

NOTE:

Vehicles sold in Canada and Mexico DO NOT have 9-1-1 Call system capabilities. 9-1-1 or other emergency line operators in Canada and Mexico may not answer or respond to 9-1-1 system calls.

2. The Uconnect® “Apps” button on the menu bar at the bottom right corner of the radio touchscreen. This is where you can begin your registration process, manage your Apps and purchase WiFi on demand.
3. The Uconnect® Voice Command and Uconnect® Phone buttons are located on the left side of your steering wheel. These buttons let you use your voice to give commands, make phone calls, send and receive text messages hands-free, enter navigation destinations, and control your radio and media devices.

Included Trial Period For New Vehicles

Your new vehicle may come with an included trial period for use of the Uconnect® Access Services starting at the date of vehicle purchase (date based on vehicle sales notification from your dealer). **To activate the trial, you must first register with Uconnect® Access.** After the trial period, if you wish to continue your Uconnect® Access Services you can choose to purchase a subscription.

Features And Packages

- After the trial period, you can subscribe to continue your service by visiting the Uconnect® Store located within the Mopar Owner Connect website moparownerconnect.com. If you need assistance, U.S. residents can call Uconnect® Care at 1-855-792-4241.
- For the latest information on packages and pricing information: U.S. residents visit DriveUconnect.com.

Uconnect® Access Registration (Uconnect® 8.4A/8.4AN, U.S. 48 Contiguous States, Alaska And Hawaii)

To unlock the full potential of Uconnect® Access in your vehicle, you first need to register with Uconnect® Access.

1. From the parked vehicle with the radio touchscreen powered on, select the “Apps” button located near the bottom right-hand corner of the radio touchscreen.

NOTE:

Should you require assistance anytime during the registration process, simply call Uconnect® Care at 1-855-792-4241.

2. Press “Start” on the reminder screen or select “Uconnect Registration” under the “All Apps” or “Favorites Apps” tab on the Apps list.
3. The Uconnect® Access Registration App will open and display step-by-step instructions to start your registration.
4. Enter your email address into the radio touchscreen.
5. A message will display on the touchscreen indicating your email submission was accepted. In a few minutes, you will receive an email which will allow you to register your vehicle for Uconnect® Access. You should open this email and begin your Uconnect® Access registration within 72 hours.
6. Check for an email from Uconnect® Access that contains your personalized registration link. If you don't see it, check your spam or junk mail folder. Open the email and click on the link to continue registering.

NOTE:

For security reasons, this link is valid for 72 hours from the time you've submitted your email address into the radio touchscreen. If the link has expired, simply re-enter your email address into the Uconnect® Registration App on the radio touchscreen to receive another link. The secured registration link will take you through the Uconnect® Access registration process step by step.

7. To unlock the full potential of Uconnect® Access in your vehicle, you will need to create or validate an existing Mopar Owner Connect account previously (Owner Center). Uconnect® along with Mopar Owner Connect have joined forces to create one destination to manage all of your vehicle needs, from managing your Uconnect® Access account, to tracking service history and finding recommended accessories for your vehicle. If you already have a Mopar Owner Connect account, log in to the website with your existing username/email and password. For assistance with this web based registration process, call Uconnect® Care at 1-855-792-4241.
8. Once you are logged in to your Mopar Owner Connect account, you will create a personal Uconnect® Security PIN. The Uconnect® Security PIN will be required to authenticate you when accessing your account via Uconnect® Care or performing any remote services such as Remote Door Lock/Unlock, Remote Horn & Lights or Starting and Stopping the engine.

9. If your vehicle qualifies for a trial package it will be presented. Simply agree to the Uconnect® Terms of Service (checkbox) and then select the “Start Service” button.

At this point your vehicle is registered with Uconnect® Access. Continue to set up Via Mobile. Apps will be downloaded the next time you start your vehicle. If the Apps have not appeared after 24 hours, please contact Uconnect® Care.

Download The Uconnect® Access App

The Uconnect® Access smartphone app allows you to remotely lock or unlock your doors, start your engine (if equipped) and activate your horn and lights from virtually anywhere. The smartphone app also features Via Mobile (if equipped) which uses your smartphone's data plan to access your personal Pandora®, iHeartRadio, Slacker Radio and Aha™ by HARMAN accounts and control them using your vehicle touchscreen.

The Uconnect® Access app is only compatible with select iPhone® and Android smartphones. Visit UconnectPhone.com or call 1-877-855-8400 to confirm that your smartphone is compatible with Uconnect®. Once you've confirmed your smartphone is compatible, Android and iPhone® users should visit their respective app store and search for “Uconnect Access” to download the app.

Set Up Your Via Mobile Profile — If Equipped

Setting up your Via Mobile profile means entering your login information for each App so that they can work in your vehicle. Complete your Via Mobile Profile online during registration of your Uconnect® Access system. Access this page by logging into your Mopar Owner Connect account (moparownerconnect.com), going to Edit Profile, then Via Mobile Profile.

If you already have an account with these Apps, scroll down and press the “Link” button to enter your information. If you do not have an account, you can create a new one.

Aha™ by HARMAN (www.aharadio.com)

- Enter your email address and password for Aha™, or create a new Aha™ account.
- You can link your Facebook, Twitter or Slacker accounts on the Aha™ website.

iHeartRadio (www.iHeartRadio.com)

- Enter your email address and password for iHeartRadio, or create a new iHeartRadio account.
- Select “Activate” to continue,
- Select “Close” to complete activation.

Pandora® (www.pandora.com)

- Enter your Pandora® username/email address and password, then click “Save.”
- Create a new Pandora® account.

Slacker Radio (www.slacker.com)

- Enter your Slacker username/email address and password, then click “Save.”
- Create a new Slacker Radio account.

Invite family and friends to use the Via Mobile Apps in your vehicle by setting up their own Via Mobile profile.

Renewing Subscriptions And Purchasing WiFi Hotspot (Uconnect® 8.4A/8.4AN, U.S. 48 Contiguous States And Alaska)

Subscriptions, and WiFi Hotspot, can be purchased from the Uconnect® Store within your vehicle, and online at Mopar Owner Connect. If you need help push the ASSIST button on the rearview mirror, then select Uconnect® Care (or dial 1-855-792-4241).

Purchasing Online

You can renew your subscription to a package or purchase WiFi from the Mopar Owner Connect website. You must first set up a Uconnect® Access Payment Account online. Log into moparownerconnect.com

1. Log In to the Mopar Owner Connect website (moparownerconnect.com) with your username/email and password.
2. Click on the “Shop” tab, then click on the Uconnect® Store.
3. From the Uconnect® Store, select the item you wish to purchase.
4. This will launch the selected item into purchase mode along with providing additional information.
5. The Uconnect® Store will display a “Purchase Overview” message confirming the financial details of your purchase. Click the “Purchase” key to continue.
6. The Uconnect® Store will ask you to “Confirm Payment” using your default payment method on file in your Payment Account. Click the “Complete” key to continue.
7. The Uconnect® Payment Account will then ask for your “Payment Account PIN,” which you established when setting up your Uconnect® payment account. After entering this four digit PIN, click the “Complete” key to make the purchase.
8. You will receive a confirmation message that your purchase has been submitted. Click the “OK” button to end the process.

Purchasing WiFi Hotspot While In Your Vehicle

You must set up a Uconnect® Access Payment Account online (log in to moparownerconnect.com, go to Edit Profile, then Uconnect® Payment Account, to set up and manage your Payment Account).

1. To purchase WiFi while in your vehicle, ensure the vehicle is running and in Park. Press the “Apps” button on the touchscreen, then select WiFi within the “Apps” menu. Follow the on-screen instructions. When asked for your payment PIN, use the 4-digit PIN you established when setting up your payment account on Mopar Owner Connect.

NOTE:

This may be different than the Uconnect® Security PIN you established for using features such as Remote Vehicle Start. After purchasing WiFi, it may take up to 30 minutes (with the vehicle running) before the WiFi will be active in your vehicle.

2. Select WiFi again, then note the hotspot name. Select this network when connecting devices to the hotspot. Also click on View/Edit Passphrase, then note the security passphrase you will need to connect to the network on each device.

If your devices cannot see the WiFi Hotspot network after 30 minutes, please contact Uconnect® Care by pushing the ASSIST button on the rearview mirror, or by calling 1-855-792-4241.

Using Uconnect® Access

Getting Started With Apps

Applications (Apps) and features in your Uconnect® Access system deliver services that are customized for the driver and are certified by Chrysler Group, LLC. Two different types are:

1. **Built-In Features** — use the built-in 3G Cellular Network on your Uconnect® 8.4A/8.4AN radio.
2. **Uconnect® Access Via Mobile** (if equipped) — Via Mobile uses the Uconnect® Access app and your smartphone's data plan to access your personal Pandora®, iHeartRadio, Aha™ by HARMAN and Slacker Radio accounts from the vehicle and control them using the vehicle touchscreen. Customer's data plan charges will apply. Available on Uconnect® 8.4A and 8.4AN Radios (if equipped).

Get started with your Uconnect® Access apps by pressing the Uconnect® “Apps” button on the menu bar at the bottom right corner of the radio touchscreen. Available apps and features are organized by the tabs on the left of the screen:

Favorite Apps — This is the default screen when you first press the “Apps” button on the touchscreen, and is a good place to put the apps you use most frequently. To make an App a “favorite”, press the star button next to the app name and confirm the prompt with “yes.”

All Apps — Organizes your Uconnect® Access apps (when available).

Running Apps — Press this tab to see which apps are currently running.

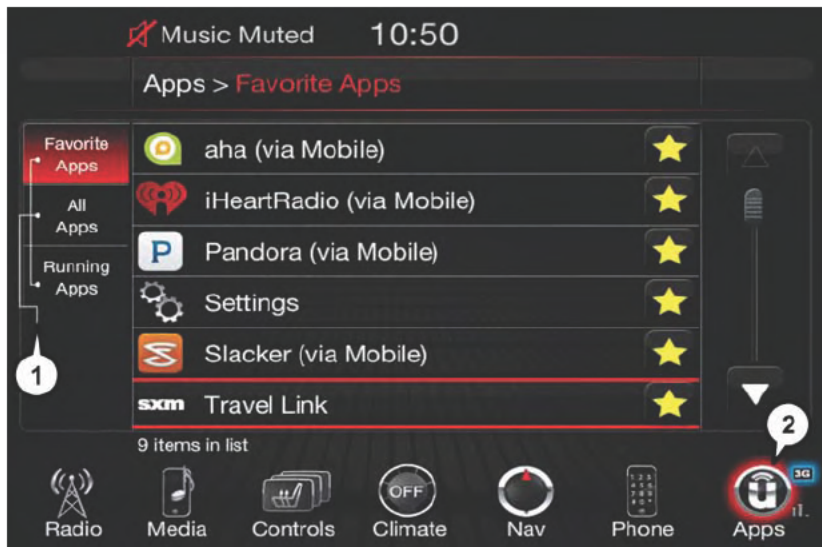

Favorite Apps

1 — Category Tabs

2 — Apps Button

Maintaining Your Uconnect® Access Account

Reinstalling An App (Uconnect® 8.4A/8.4AN)

You can easily correct many Application related issues you may be experiencing by resetting the App back to the factory setting. From the vehicle's radio touchscreen, complete the following steps:

1. Press the Uconnect® "Apps" button and open the Uconnect® Store. Go to My Apps.
2. In My Apps, select "Settings," then "Reinstall App." Press "Continue."
3. Your Apps have been successfully re-installed.

Canceling Your Subscription

Should you want to cancel your subscription, you can remove your account information using the same procedure contained in the Selling Your Vehicle section.

Selling Your Vehicle

When you sell your vehicle, we recommend that you remove your Uconnect® Access Account information from the vehicle. You can do this using the radio touchscreen in the vehicle or on the Mopar Owner Connect website (moparownerconnect.com). Removing your account information cancels your subscription and makes your vehicle factory-ready for a new owner/subscriber.

1. From your vehicle's radio touchscreen, select "Uconnect® Store" from the Apps Menu.
2. Select "My Apps," then "Settings." Press "Remove Uconnect® Account."
3. Enter your Uconnect® Security PIN, and select "Continue."

For additional information on Uconnect®:

- U.S. residents - visit DriveUconnect.com or call 1-877-855-8400.
- Canadian Residents - visit DriveUconnect.ca or call, 1-800-465-2001 (English) or 1-800-387-9983 (French).

Built-In Features (Uconnect® 8.4A/8.4AN)

CAUTION!

- Ignoring the rearview mirror light could mean you may not have 9-1-1 Call service if needed. If the rearview mirror light is illuminated, have an authorized dealer service the 9-1-1 Call system immediately.
- The Occupant Restraint Controller (ORC) turns on the Air Bag Warning Light on the instrument panel if a malfunction is detected in any part of the air bag system. If the Air Bag Warning Light is illuminated, the air bag system may not be working properly and the 9-1-1 system may not be able to send a signal to a 9-1-1 operator. If the Air Bag Warning Light is illuminated, have an authorized dealer service your vehicle immediately.
- If anyone in the vehicle could be in danger (e.g., fire or smoke is visible, dangerous road conditions or location), do not wait for voice contact from a 9-1-1 operator. All occupants should exit the vehicle immediately and move to a safe location.
- Do not add any aftermarket electrical equipment to the vehicle's electrical system. This may prevent your vehicle from sending a signal to initiate an emergency call. To avoid interference that can cause the 9-1-1 Call system to fail, never add aftermarket equipment (e.g., two-way mobile radio, CB radio, data recorder, etc.) to your vehicle's electrical system or modify the antennas on your vehicle. IF YOUR VEHICLE LOSES BATTERY POWER FOR ANY REASON (INCLUDING DURING OR AFTER AN ACCIDENT), THE UCONNECT® FEATURES, APPS AND SERVICES, AMONG OTHERS, WILL NOT OPERATE.

1. **Assist Call** – The rearview mirror contains an ASSIST push button which (once registered) automatically connects the vehicle occupants to one of these predefined destinations for immediate support:

- **Roadside Assistance Call** — If you get a flat tire, or need a tow, you'll be connected to someone who can help anytime. Additional fees may apply. Additional information in this section.
- **Uconnect® Access Care** — In vehicle support for Uconnect® Access System, Apps and Features.
- **Vehicle Care** — Total support for your Chrysler Group LLC vehicle.



ASSIST/9-1-1 Buttons

2. **Emergency 9-1-1 Call (If Equipped)** —

The rearview mirror contains a 9-1-1 button that, when pressed, may place a call from your vehicle to a local 9-1-1 operator to request help from local police, fire or ambulance personnel. If this button is accidentally pushed, you will have 10 seconds to stop the call. To cancel, push the 9-1-1 Call button again or press the “cancel” button shown on the touchscreen. After 10 seconds has passed, the 9-1-1 call will be placed and only the 9-1-1 operator can cancel it. The LED light on the rearview mirror will turn green once a connection to a 9-1-1 operator has been made. The green LED light will turn off once the 9-1-1 call is terminated. Have an authorized dealer service the vehicle if the rearview mirror light is continuously red. On equipped vehicles, this feature requires a functioning electrical system and wireless coverage to function properly. **If a connection is made between a 9-1-1 operator and your vehicle, you understand and agree that 9-1-1 operators may, like any other 9-1-1 call, record conversations and sounds in and near your vehicle upon connection.**

- 1 — ASSIST Button
2 — 9-1-1 Button
-

3. **Roadside Assistance (If Equipped)** — If your vehicle is equipped with this feature and within wireless range, you may be able to connect to Roadside Assistance by pushing the “ASSIST” button on the rearview mirror. You will be presented with Assist Care options. Make a selection by pressing the prompts displayed on the radio. If Roadside Assistance is provided to your vehicle, you agree to be responsible for any additional roadside assistance service costs that you may incur. To provide Uconnect® Services to you, we may record and monitor your conversations with Roadside Assistance, Uconnect® Care or Vehicle Care, whether such conversations are initiated through the Uconnect® Services in your vehicle, or via a landline or mobile telephone, and may share information obtained through such recording and monitoring in accordance with regulatory requirements. You acknowledge, agree and consent to any recording, monitoring or sharing of information obtained through any such call recordings.

4. **Yelp®** — Customers have the ability to search for nearby destinations or a point of interest (POI) either by category or custom search by using keywords (for example, “Italian restaurant”). Searching can be done by either voice or by using the touch-screen keypad. Using the touchscreen, launch Yelp® by selecting the “Apps” icon, press the “All Apps” tab, and then press “Yelp.” Using voice recognition, push the Voice Command (VR) button on the steering wheel and say “Launch Yelp®.”
5. **Security Alarm Notification** — The Security Alarm Notification feature notifies you via email or text (SMS) message when the vehicle’s factory-installed security alarm system has been set-off. There are a number of reasons why your alarm may have been triggered, one of which could be that your vehicle was stolen. If so, please see the details of the Stolen Vehicle Assistance service below. When you register, Security Alarm Notification is automatically set to send you an email at the mail address you provide should the alarm go off. You may also opt to have a text message sent to your mobile device.
6. **Stolen Vehicle Assistance** — If your vehicle is stolen, contact local law enforcement immediately to file a stolen vehicle report. Once this report has been filed, Uconnect® care can help locate your vehicle. The Uconnect® Care agent will ask for the stolen vehicle report number issued by local law enforcement. Then, using GPS technology and the built-in wireless connection within your vehicle, the Uconnect® Care agent will be able to locate the stolen vehicle and work with law enforcement to help recover it. (Vehicle must be within the United States, have network coverage and must be registered with Uconnect® Access with an active subscription that includes the applicable feature).
7. **WiFi Hotspot** — WiFi Hotspot is on-demand WiFi 3G connectivity that’s built-in and ready to go whenever you are. Once your vehicle is registered for Uconnect® Access, you can purchase a Wifi Hotspot subscription at the Uconnect® Store. After you’ve made your purchase, turn on your signal and connect your passengers devices. It’s never been easier to bring your home or office with you.

NOTE:

Your vehicle must have a working electrical system for any of the in vehicle Uconnect® features to operate.

Uconnect® Access Remote Features

If you own a compatible iPhone® or Android® powered device, the Uconnect® Access App allows you to remotely lock or unlock your doors, start your engine or activate your horn and lights from virtually anywhere (Vehicle must be within the United States and have network coverage). You can download the App from Mopar Owner Connect or from the App Store (iPhone) or Google Play store. Visit UconnectPhone.com to determine if your device is compatible. For Uconnect® Phone customer support and to determine if your device is compatible.

U.S. residents - visit UconnectPhone.com or call 1-877-855-8400

Remote Start — This feature provides the ability to start the engine on your vehicle, without the keys and from virtually any distance. You can send a request to your vehicle in one of two ways:

1. Using the Uconnect® Access App from a compatible smartphone.
2. From the Mopar Owner Connect website.
 - After 15 minutes if you have not entered your vehicle with the key, the engine will shut off automatically.
 - You can also send a command to turn-off an engine that has been remote started.
 - This remote function requires your vehicle to be equipped with a factory-installed Remote Start system. To utilize this feature after the Uconnect® Access App is downloaded, login with your user name and password.

NOTE:

Your four digit Uconnect® Security PIN is required to confirm the request.

- You can set-up notifications for your account to receive an email or text (SMS) message every time a command is sent. Login to Mopar Owner Connect (moparownerconnect.com) and click on Edit Profile to manage Uconnect® Notifications.

Remote Door Lock/Unlock — This feature provides the ability to lock or unlock the door on your vehicle, without the keys and from virtually any distance. You can send a request to your vehicle in one of three ways:

1. Using the Uconnect® Access App from a compatible smartphone.
2. From the Mopar Owner Connect website.
3. By contacting the Uconnect® Care on the phone.

To use this feature after the Uconnect® Access App is downloaded, login using your user name and password. You will need your four digit Uconnect® Security PIN to confirm the request. Press the “closed lock” icon on your Uconnect® Access App to lock the doors, and press the “open Lock” icon to unlock the driver’s door.

You can set-up notifications for your account to receive an email or text (SMS) message every time a command is sent. Login to Mopar Owner Connect (moparownerconnect.com) and click on Edit Profile to manage Uconnect® Notifications.

Remote Horn And Lights — It's easy to locate a vehicle in a dark, crowded or noisy parking area by activating the horn and lights. It may also help if you need to draw attention to your vehicle for any reason. You can send a request to your vehicle in one of three ways:

1. Using the Uconnect® Access App from a compatible smartphone.
2. From the Mopar Owner Connect website.
3. By contacting the Uconnect® Care on the phone.

To use this feature after the Uconnect® Access App is downloaded, login using your user name and password. You will need your four digit Uconnect® Security PIN to confirm the request. You can set-up notifications for your account to receive an email or text (SMS) message every time a command is sent. Login to Mopar Owner Connect (moparownerconnect.com) and click on Edit Profile to manage Uconnect® Notifications.

Voice Texting — Want to dictate a personal message? Register with Uconnect® Access to take advantage of a new, cloudbased Voice Texting service, an enhancement to Voice Text Reply.

Voice Texting allows you to compose a new text or reply to an incoming text message. Before you attempt to use the Voice Texting feature, check to ensure you have the following:

1. A paired, Bluetooth® enabled phone with the Message Access Profile (MAP). Not all Bluetooth® enabled phones support MAP, including all iPhones® (Apple iOS). Visit UconnectPhone.com for system and device compatibility information.
2. An active Uconnect® Access trial or paid subscription. Press the “Apps” button on the lower right hand corner of the touchscreen to begin the registration process.
3. Accept the “Allow MAP” profile request on your smart phone. (Please refer to device manufacturer instructions for details).

To Send A Text Message:

1. Push the Uconnect® Phone Button  on the steering wheel.
2. Wait for the beep.
3. Say “Text.”
4. Uconnect® will prompt you “Say the phone number, or full name and phone type of the contact you want to send a message to.”
5. Wait for the beep and say a contact that is in your phonebook, or a mobile phone number that you would like to send the message to.
6. Uconnect® will prompt you “Please say the message that you would like to send.” (If you do not hear this prompt, you may not have an active subscription with Uconnect® Access).

7. Wait for the beep, and then dictate any message up to 140 characters. If you exceed 140 characters, you will hear the following prompt: "Message was too long; your message will be truncated."
8. Uconnect® will then repeat the message back to you.
9. Uconnect® will prompt you: "To add to your message, say "Continue"; To delete the current message and start over, say "Start Over"; to send the current message, say "Send"; to hear the message again, say "Repeat".
10. If you are happy with your message and would like to send it, wait for the beep and say "Send".
11. Uconnect® will then say "Sending your message."

Sample Commands For Voice Text Reply And Voice Texting

Example Command	Action
"Text John Smith"	Send a message to specific contact in address book
"Text 123 456 7890"	Send 123 456 7890 a message from your phonebook
"Show messages"	See recent text messages listed by number on Uconnect® screen
"Listen to/view (message number four, for example)"	Hear messages or read it on Uconnect® screen
"Reply"	Send a voice text reply to a current message
"Forward text/message to "John Smith"	Forward current text to specific contact in address book
"Forward text/message to "123 456 7890"	Forward current text to specific phone number

Uconnect® Access Via Mobile — If Equipped (Available On Uconnect® 8.4A/8.4AN)

Via Mobile uses the Uconnect® Access app and your smartphone's data plan to access your personal Pandora®, iHeartRadio, Aha™ by HARMAN and Slacker Radio accounts from the vehicle and control them using the vehicle touchscreen. Customer's data plan charges will apply.

To get started using Via Mobile apps, first register your Uconnect® Access system where you'll be guided through the setup of your Via Mobile (requires a compatible Android or iPhone® smartphone). Please refer to "Uconnect® Access Registration" for more information.

The Uconnect® Access app is compatible with select iPhone® and Android smartphones. Visit UconnectPhone.com to confirm that your smartphone is compatible with Uconnect®. Once you've confirmed your smartphone is compatible, pair it to the vehicle touchscreen via Bluetooth® to use Via Mobile apps. If using an iPhone®, a USB cable is also supported for the data connection.

Launch the Uconnect® Access App on your smartphone, and login with your username and password that was set up during registration, (this is your moparownerconnect.com login). Accept the Terms and Conditions.

- Ensure that Via Mobile data has been turned on under "Settings" in the Uconnect® Access App.
- A green indicator next to the words Via Mobile will show when it is ready to provide data to the radio (a blue indicator when data is being sent). A red indicator means that it is not ready to provide data.
- On android phones, an orange/yellow indicator signals the phone is connected to the appropriate servers however, Bluetooth® is turned off on their mobile phone.

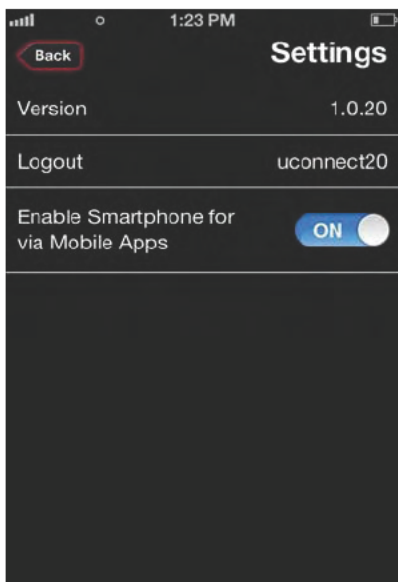

Via Mobile Data Enabled

Each time you want to use a Via Mobile app in your vehicle, the Uconnect® Access App must be running on your smartphone and the smartphone must be paired via Bluetooth®.

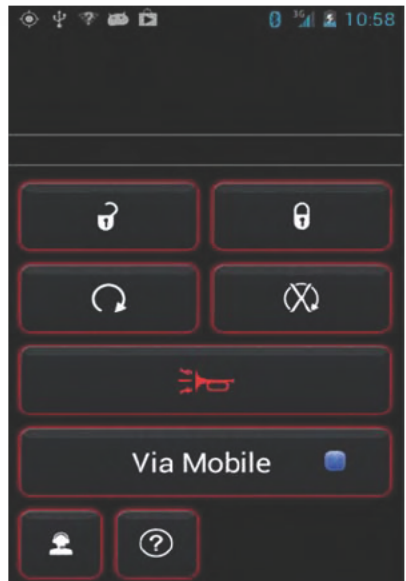

Data Being Sent

If equipped, the Via Mobile apps can be found by selecting the “Apps” button on the touchscreen in the lower right corner of the radio touchscreen. Via Mobile apps are listed under the “All Apps” tab. The words “Via Mobile” will appear after the app name indicating it is a Via Mobile app.

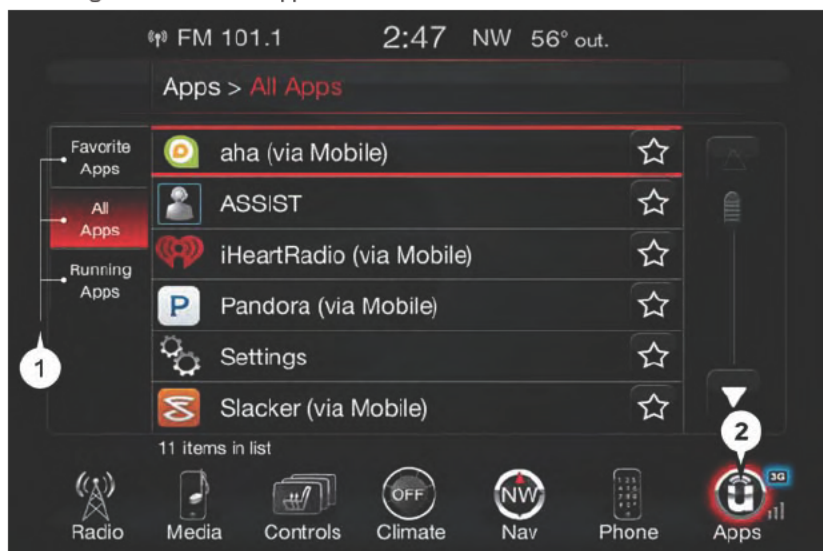

All Apps

1 — Category Tabs

2 — Apps Button

Via Mobile apps can also be launched through Voice Recognition by pressing the VR button on the steering wheel and stating “launch” and then the name of the app. For example, you can say “launch Aha Via Mobile.”

NOTE:

For detailed information on how to use Via Mobile apps visit the Mopar Owner Connect website (moparownerconnect.com) and login using the username and password you set up when registering for Uconnect® Access.

A message will be displayed to remind you that Via Mobile apps utilize the data plan on your connected smartphone to provide content. Many smartphones have a limit to how much data they can utilize before incurring additional charges. The amount of data being used varies by smartphone device, cellular service provider and specific app. Check your mobile phone service plan for more details.* Press “OK” to continue or the “X” to exit.

(*Additional smartphone data usage charges may apply.)

Via Mobile Apps — If Equipped

- **Aha™ by HARMAN** — Aha™ by HARMAN makes it easy to instantly access your favorite Web content on the go. Choose from over 40,000+ stations spanning internet radio, personalized music, news, entertainment, hotels, weather, audiobooks, Facebook®, Twitter®, and more.
- **iHeartRadio** — iHeartRadio provides instant access to more than 1,500 live radio stations from across the country and allows listeners to create custom music stations inspired by their favorite artists or songs.
- **Pandora®** — Pandora® gives people the music and comedy they love anytime, anywhere. Personalized stations launch instantly, with the input of a favorite artist, track, comedian, or genre.
- **Slacker Radio** — Enjoy millions of songs and hundreds of handcrafted stations.

NOTE:

For detailed information on how to use Via Mobile apps visit the Mopar Owner Connect website (moparownerconnect.com) and log in using the username and password you set up when registering for Uconnect® Access.

Uconnect® 5.0



Uconnect® 5.0

- | | |
|--------------------------------|------------------------------|
| 1 — Preset Buttons | 10 — Direct Tune Button |
| 2 — SEEK Up Button | 11 — AM/FM/SXM Button |
| 3 — Compass Information Button | 12 — Screen Off Button |
| 4 — Climate Functions Button | 13 — Volume Knob/Mute Button |
| 5 — + MORE Functions Button | 14 — SEEK Down Button |
| 6 — Browse/Enter Button | 15 — Uconnect® Phone Button |
| 7 — Back Button | 16 — Media Mode Button |
| 8 — Audio Button | 17 — Radio Mode Button |
| 9 — Info Button | |

Clock Setting

To start the clock setting procedure:

1. Push the + MORE button on the faceplate. Next press the “Settings” button on the touchscreen and then press the “Clock and Date” button on the touchscreen.
2. Press the “Set Time” button on the touchscreen.
3. Press the “Up” or “Down” arrows to adjust the hours or minutes, then select the “AM” or “PM” button on the touchscreen. You can also select 12hr or 24hr format by pressing the desired button on the touchscreen.

4. Once the time is set press the “Done” button on the touchscreen to exit the time screen.

NOTE:

In the Clock Setting Menu you can also select Display Clock. Display Clock turns the clock display in the status bar on or off.

Equalizer, Balance And Fade

1. Push the + MORE button on the faceplate, then press the “Settings” button on the touchscreen.
2. Scroll down and press the “Audio” button on the touchscreen to open the Audio menu.

The Audio Menu shows the following options for you to customize your audio settings.

Equalizer

- Press the “Equalizer” button on the touchscreen to adjust the Bass, Mid and Treble. Use the “+” or “-” button on the touchscreen to adjust the equalizer to your desired settings. Press the “back arrow” button on the touchscreen when done.

Balance/Fade

- Press the “Balance/Fade” button on the touchscreen to adjust the sound from the speakers. Use the “arrow” button on the touchscreen to adjust the sound level from the front and rear or right and left side speakers. Press the Center “C” button on the touchscreen to reset the balance and fade to the factory setting. Press the “back arrow” button on the touchscreen when done.

Speed Adjustable

- Press the “Speed Adjusted Volume” button on the touchscreen to select between OFF, 1, 2 or 3. This will decrease the radio volume relative to a decrease in vehicle speed. Press the “back arrow” button on the touchscreen when done.

Loudness

- Press the “Loudness” button on the touchscreen to select the Loudness feature. When this feature is activated it improves sound quality at lower volumes. Press the “back arrow” button on the touchscreen when done.

Radio Operation**Seek Up ►► / Seek Down ◀◀**

- Press to seek through radio stations in AM, FM or SXM bands.
- Hold either button to bypass stations without stopping.

Store Radio Presets

When you are receiving a station that you wish to commit into memory, press and hold the desired numbered button on the touchscreen for more than two seconds or until you hear a confirmation beep.

The Radio stores up to 12 presets in each of the Radio modes. Four presets are visible at the top of the radio screen. Pressing the “All” button on the touchscreen on the radio home screen will display all of the preset stations for that mode.

SiriusXM Premier Over 160 channels

Get every channel available on your satellite radio, and enjoy all you want, all in one place. Hear commercial-free music plus sports, news, talk and entertainment. Get all the premium programming, including Howard Stern, every NFL game, Oprah Radio®, every MLB® and NHL® game, every NASCAR® race, Martha Stewart and more. And get 20+ extra channels, including SiriusXM Latino, offering 20 channels of commercial free music, news, talk, comedy, sports and more dedicated to Spanish language programming.

- To access SiriusXM™ Satellite Radio, push the “RADIO” button on the faceplate and then the “SXM” button on the touchscreen.
- SiriusXM services require subscriptions, sold separately after the 12-month trial included with the new vehicle purchase. **If you decide to continue your service at the end of your trial subscription, the plan you choose will automatically renew and bill at then-current rates until you call SiriusXM at 1-866-635-2349 for U.S. residents and 1-888-539-7474 for Canadian residents to cancel. See SiriusXM Customer Agreement for complete terms at www.siriusxm.com for U.S. residents and www.siriusxm.ca for Canadian residents.** All fees and programming subject to change. Our satellite service is available only to those at least 18 and older in the 48 contiguous USA and D.C. Our Sirius satellite service is also available in PR (with coverage limitations). Our Internet radio service is available throughout our satellite service area and in AK and HI. © 2014 Sirius XM Radio Inc. Sirius, XM and all related marks and logos are trademarks of Sirius XM Radio Inc.

Disc Operation

Your vehicle may have a remote CD player located in the lower center console storage bin.

- CD/Disc Mode is entered by either inserting a CD/Disc or by pressing the “+ MEDIA” button on the touchscreen. Once in Media Mode, select “Disc.”
- Gently insert one CD into the CD player with the CD label facing as indicated on the illustration located on the Disc player.

Seek Up/Down Buttons

- Press to seek through Disc tracks.
- Hold either button to bypass tracks without stopping.

Browse

- Press the “Browse” button on the touchscreen to scroll through and select a desired track on the Disc. Press the “Exit” button on the touchscreen if you wish to cancel the browse function.

MEDIA HUB — iPod®/USB/MP3/SD Card**USB/iPod®**

- USB/iPod® Mode is entered by either inserting a USB Jump Drive or iPod® cable into the USB port or by pushing the MEDIA button located left of the display. Once in Media Mode, press the “source” button on the touchscreen and select “USB/iPod.”
- Push the MEDIA button on the faceplate then press the “source” button on the touchscreen. Select “USB/iPod” to change the mode to the USB device if the device is connected, allowing the music from your portable device to play through the vehicle's speakers.

Audio Jack (AUX)

The AUX allows a portable device, such as an MP3 player or an iPod®, to be plugged into the radio and utilize the vehicle's audio system, using a 3.5 mm stereo audio cable, to amplify the source and play through the vehicle speakers.

- Push the MEDIA button on the faceplate, then press the “source” button on the touchscreen and select “AUX” to change the mode to auxiliary device if the audio jack is connected, allowing the music from your portable device to play through the vehicle's speakers.

The functions of the portable device are controlled using the device buttons, not the buttons on the radio. The volume may be controlled using the radio or portable device.

Bluetooth®

If using a Bluetooth® - equipped device, you may also be able to stream music to your vehicle's sound system.

- Push the MEDIA button on the faceplate, then press the “source” button on the touchscreen. Select “Bluetooth” to change the mode to Bluetooth® if the device is paired, allowing the music from your portable device to play through the vehicle's speakers.

SD Card

SD Card Mode allows you to play music that has been saved to your SD Card through your vehicle's sound system.

- You can enter SD Card Mode by either inserting a SD Card into the SD Card slot or by pushing the “SD Card” button on the left side of the display while in media mode.

For further information refer to your Radio Supplement.

Voice Text Reply (Not Compatible With iPhone®)

Once your Uconnect® system is paired with a compatible mobile device, the system can announce a new incoming text message, and read it to you over the vehicle audio system. You can reply to the message using Voice Recognition by selecting, or saying, one of the 18 pre-defined messages.

Here's How:

1. Push the Uconnect® Phone button  and wait for the beep, then say "reply." Uconnect® will give the following prompt: "Please say the message you would like to send."
2. Wait for the beep and say one of the pre-defined messages. (If you are not sure, you can say "help"). Uconnect® will then read the pre-defined messages allowed.
3. As soon as you hear the message you would like to send, you can interrupt the list of prompts by pushing the Uconnect® phone button and saying the phrase. Uconnect® will confirm the message by reading it back to you.
4. Push the Phone button and say "Send."

PRE-DEFINED VOICE TEXT REPLY RESPONSES

Yes.	Stuck in Traffic.	See you later.
No.	Start without me.	I'll be Late.
Okay.	Where are you?	I will be <number> minutes late.
Call me.	Are you there yet?	
I'll call you later.	I need directions.	See you in <number> of minutes.
I'm on my way.	Can't talk right now.	
I'm lost.		

NOTE:

Voice texting reply and voice texting features require a compatible mobile device enabled with Bluetooth® Message Access Profile (MAP). iPhone® and some other smartphones do not currently support Bluetooth® MAP. Visit UconnectPhone.com for system and device compatibility.

Want to dictate a personal message? You must first register with Uconnect® Access (U.S. residents only) to take advantage of a new, cloud-based Voice Texting service, an enhancement to Voice Text Reply.

Uconnect® 5.0 VOICE RECOGNITION QUICK TIPS

Introducing Uconnect®

Start using Uconnect® Voice Recognition with these helpful quick tips. It provides the key Voice Commands and tips you need to know to control your Uconnect® 5.0 system.

Key Features:

- 5" touchscreen
- Three buttons on either side of the display



Uconnect® 5.0

Get Started

1. Visit UconnectPhone.com to check mobile device and feature compatibility and to find phone pairing instructions.
2. Reduce background noise. Wind and passenger conversations are examples of noise that may impact recognition.
3. Speak clearly at a normal pace and volume while facing straight ahead. The microphone is positioned on the rearview mirror and aimed at the driver.

4. Each time you give a Voice Command, you must first push either the VR or Phone button, wait until **after** the beep, then say your Voice Command.
5. You can interrupt the help message or system prompts by pushing the VR or Phone button and saying a Voice Command from current category.

All you need to control your Uconnect® system with your voice are the buttons on your steering wheel.

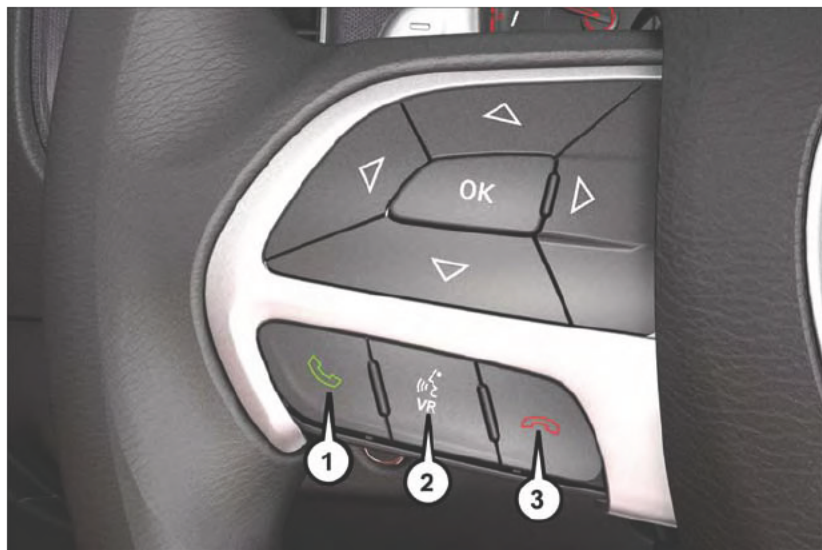

Uconnect® VR/Phone Buttons

- 1 — Push To Initiate Or To Answer A Phone Call, Send Or Receive A Text
 - 2 — Push To Begin Radio Or Media Functions
 - 3 — Push To End Call
-

Basic Voice Commands

The basic Voice Commands below can be given at any point while using your Uconnect® system.

Push the VR button  VR . After the beep, say:

- **Cancel** to stop a current voice session
- **Help** to hear a list of suggested Voice Commands
- **Repeat** to listen to the system prompts again

Notice the visual cues that inform you of your voice recognition system's status. Cues appear on the touchscreen.

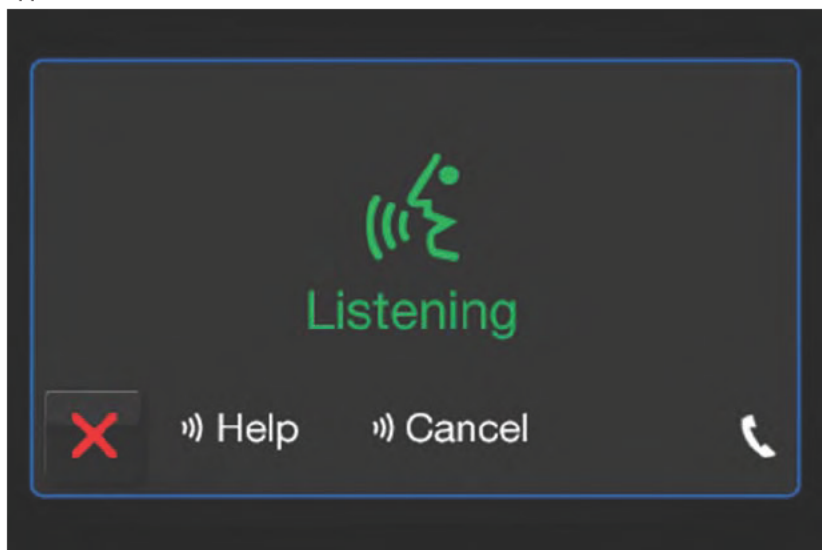

Uconnect® 5.0 Visual Cues

Radio

Use your voice to quickly get to the AM, FM or SiriusXM™ Satellite Radio® stations you would like to hear. (Subscription or included SiriusXM™ Satellite Radio trial required.)

Push the VR button  VR . After the beep, say:

- **Tune to** ninety-five-point-five FM
- **Tune to** Satellite Channel Hits 1

TIP: At any time, if you are not sure of what to say or want to learn a Voice Command, push the VR button  VR and say “**Help.**” The system will provide you with a list of commands.

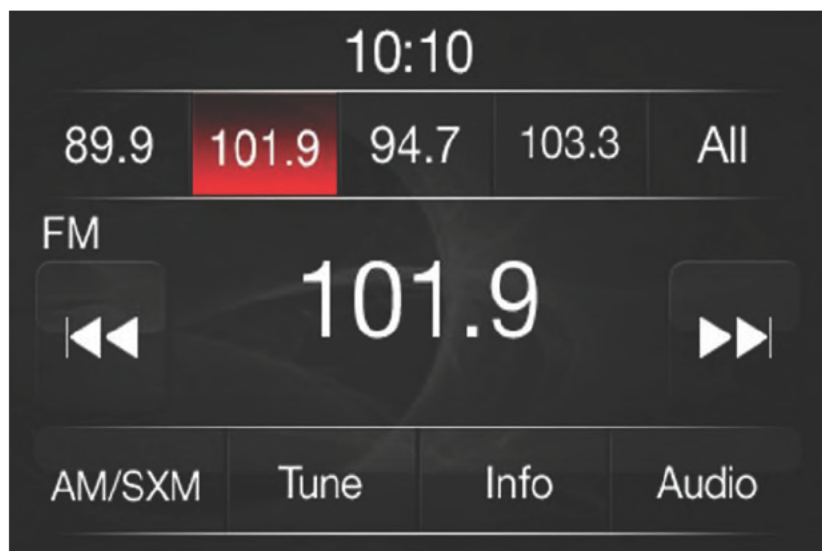

Uconnect® 5.0 Radio

Media

Uconnect® offers connections via USB, SD, Bluetooth® and auxiliary ports (If Equipped). Voice operation is only available for connected USB and iPod® devices. (Remote CD player optional and not available on all vehicles.)

Push the VR button  VR . After the beep, say one of the following commands and follow the prompts to switch your media source or choose an artist.

- **Change source** to Bluetooth®
- **Change source** to iPod®
- **Change source** to USB
- **Play artist** Beethoven; **Play album** Greatest Hits; **Play song** Moonlight Sonata; **Play genre** Classical

TIP: Press the Browse button on the touchscreen to see all of the music on your iPod® or USB device. Your Voice Command must match **exactly** how the artist, album, song and genre information is displayed.

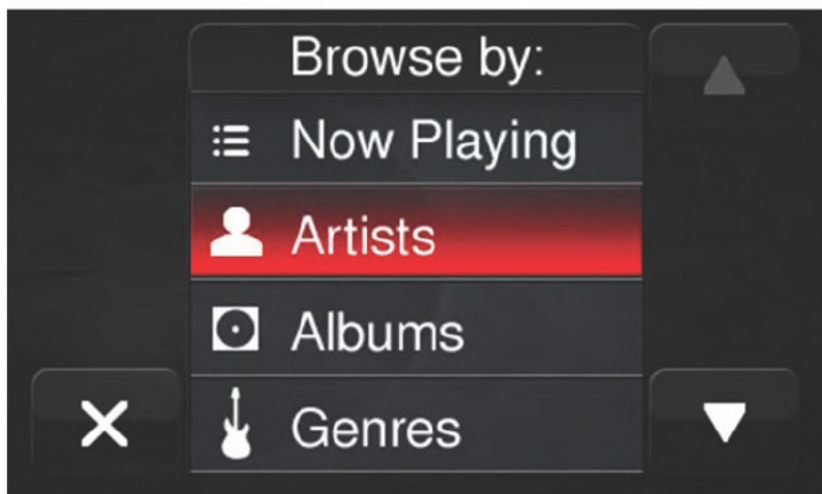

Uconnect® 5.0 Media

Phone

Making and answering hands-free phone calls is easy with Uconnect®. When the Phonebook button is illuminated on your touchscreen, your system is ready.

U.S. residents can visit UconnectPhone.com to check mobile device and feature compatibility and to find phone pairing instructions.

Push the Phone button  . After the beep, say one of the following commands...

- **Call** John Smith
- **Dial** 123-456-7890 and follow the system prompts
- **Redial** (call previous outgoing phone number)
- **Call back** (call previous incoming phone number)

TIP: When providing a Voice Command, push the Phone button  and say “**Call,**” then pronounce the name **exactly** as it appears in your phone book. When a contact has multiple phone numbers, you can say “**Call** John Smith **work.**”

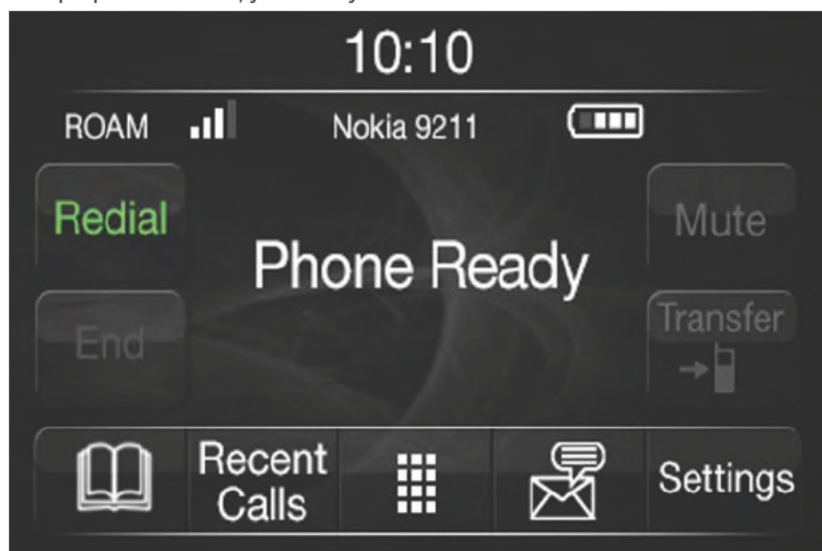

Uconnect® 5.0 Phone

Voice Text Reply

Uconnect® will announce **incoming** text messages. Push the Phone button  and say **Listen**. (Must have compatible mobile phone paired to Uconnect® system.)

1. Once an incoming text message is read to you, push the Phone button . After the beep, say: **Reply**.
2. Listen to the Uconnect® prompts. After the beep, repeat one of the pre-defined messages and follow the system prompts.

TIP: Your mobile phone must have the full implementation of the **Message Access Profile (MAP)** to take advantage of this feature. For details about MAP, visit UconnectPhone.com for U.S. residents. Apple iPhone® iOS6 or later supports reading **incoming** text messages only.

PRE-DEFINED VOICE TEXT REPLY RESPONSES		
Yes.	Stuck in Traffic.	See you later.
No.	Start without me.	I'll be Late.
Okay.	Where are you?	I will be <number> minutes late.
Call me.	Are you there yet?	
I'll call you later.	I need directions.	See you in <number> of minutes.
I'm on my way.	Can't talk right now.	
I'm lost.		Thanks.

Additional Information

© 2014 Chrysler Group LLC. All rights reserved. Mopar, Mopar Owner Connect and Uconnect are registered trademarks of Chrysler Group LLC. Android is a trademark of Google Inc. SiriusXM and all related marks and logos are trademarks of SiriusXM Radio Inc. Yelp, Yelp logo, Yelp burst and related marks are registered trademarks of Yelp.

Uconnect® System Support:

- U.S. residents visit DriveUconnect.com or call: 1-877-855-8400
- Canadian residents visit DriveUconnect.ca or call: 1-800-465-2001 (English) or 1-800-387-9983 (French)

Mon. – Fri., 7:00 am – 12:00 am, ET

Sat., 8:00 am – 10:00 pm, ET

Sun., 9:00 am – 5:00 pm, ET

Uconnect® Access Services Support 1-855-792-4241. Please have your Uconnect® Security PIN ready when you call.

Uconnect® 8.4A

Uconnect® 8.4A — If Equipped

At A Glance



Uconnect® 8.4A

- | | |
|----------------------------|---------------------|
| 1 — Status Bar | 5 — Climate Button |
| 2 — Menu Bar | 6 — Controls Button |
| 3 — Uconnect® Apps Button | 7 — Media Button |
| 4 — Uconnect® Phone Button | 8 — Radio Button |

Displaying The Time

If the time is not currently displayed on the radio or player main page:

1. Press the “Controls” button on the touchscreen or the “Apps” button on the touchscreen, then the “Settings” button on the touchscreen.
2. In the Settings list, press the “Clock” button on the touchscreen.

Setting The Time

Model 8.4AN synchronizes time automatically via GPS, so it should not require any time adjustment. If you do need to set the time manually, follow the instructions below for Model 8.4A.

1. Turn the unit on, then press the “Time Display” at the top of the screen. Press “Yes.”

NOTE:

If the time is not displayed at the top of the screen, press the “Controls” or the “Apps” button on the touchscreen, then the “Settings” button on the touchscreen. In the Settings screen, press the “Clock” button on the touchscreen.

2. Press “+” or “-” next to Set Time Hours and Set Time Minutes to adjust the time.
3. If these features are not available, uncheck the Sync with GPS box.
4. Press “X” to save your settings and exit out of the Clock Setting screen.

Audio Settings

To adjust the Audio settings:

1. Press the “Media” or “Radio” button on the touchscreen.
2. Press the “Audio” button on the touchscreen to activate the Audio settings screen to adjust Balance/Fade, Equalizer and Speed Adjusted Volume.
3. You can return to the Radio screen by pressing the “X” located at the top right.

Balance/Fade

To adjust the Balance/Fade settings:

1. Press the “Media” or “Radio” button on the touchscreen.
2. Press the “Audio” button on the touchscreen to activate the Audio settings screen to adjust Balance/Fade, Equalizer and Speed Adjusted Volume.
3. Press the “Balance/Fade” button on the touchscreen to Balance audio between the front speakers or fade the audio between the rear and front speakers.
4. Pressing the “Front,” “Rear,” “Left” or “Right” button on the touchscreens or press and drag the Speaker Icon to adjust the Balance/Fade.

Equalizer

To adjust the equalizer settings:

1. Press the “Media” or “Radio” button on the touchscreen.
2. Press the “Audio” button on the touchscreen to activate the Audio settings screen to adjust Balance/Fade, Equalizer and Speed Adjusted Volume.
3. Press the “Equalizer” button on the touchscreen to activate the Equalizer screen.
4. Press the “+” or “-” button on the touchscreens, or by pressing and dragging over the “level bar” for each of the equalizer bands. The level value, which spans between plus or minus 9, is displayed at the bottom of each of the Bands.

Speed Adjusted Volume

To adjust the speed adjusted volume settings:

1. Press the “Media” or “Radio” button on the touchscreen.
2. Press the “Audio” button on the touchscreen to activate the Audio settings screen to adjust Balance/Fade, Equalizer and Speed Adjusted Volume.

3. Press the “Speed Adjusted Volume” button on the touchscreen to activate the Speed Adjusted Volume screen. The Speed Adjusted Volume is adjusted by pressing the “volume level” indicator. This alters the automatic adjustment of the audio volume with variation to vehicle speed.

Surround Sound

To turn surround sound On/Off:

1. Press the “Media” or “Radio” button on the touchscreen.
2. Press the “Audio” button on the touchscreen to activate the Audio settings screen to adjust Balance/Fade, Equalizer and Speed Adjusted Volume.
3. Press the “Surround Sound” button on the touchscreen, select On or Off followed by pressing the “back arrow” button on the touchscreen. When this feature is activated, it provides simulated surround sound mode.

RADIO



Uconnect® 8.4A Radio

- | | |
|----------------------------|------------------------------------|
| 1 — Radio Station Presets | 5 — Direct Tune To A Radio Station |
| 2 — Toggle Between Presets | 6 — Seek Down |
| 3 — Audio Setting | 7 — Browse And Manage Presets |
| 4 — Seek Up | 8 — Choose Radio Band |

To access the Radio mode:

- Press the “Radio” button at the lower left of the touchscreen.

Selecting Radio Stations

- Press the desired radio band (AM, FM or SXM) button on the touchscreen.

Seek Up ►► / Seek Down ◀◀

- Press the “Seek arrow” button on the touchscreen for less than two seconds to seek through radio stations.
- Press and hold either “Seek arrow” button on the touchscreen for more than two seconds to bypass stations without stopping. The radio will stop at the next listenable station once the “arrow” button on the touchscreen is released.

Direct Tune

- Tune directly to a radio station by pressing the “Tune” button on the screen, and entering the desired station number.

Store Radio Presets

Your radio can store 36 total preset stations, 12 presets per band (AM, FM and SXM). They are shown at the top of your radio screen.

- To see the 12 preset stations per band, press the “arrow” button on the touchscreen at the top right of the screen to toggle between the two sets of six presets.
- To set a station into memory press and hold the desired numbered button on the touchscreen for more than two seconds or until you hear a confirmation beep.

SiriusXM Premier Over 160 Channels

Get every channel available on your satellite radio, and enjoy all you want, all in one place. Hear commercial-free music plus sports, news, talk and entertainment. Get all the premium programming, including Howard Stern, every NFL game, Oprah Radio®, every MLB® and NHL® game, every NASCAR® race and more. And get 20+ Xtra channels, including SiriusXM Latino, a selection of channels dedicated to Spanish language programming.

- To access SiriusXM Satellite Radio, press the “SXM” button on the touchscreen on the main Radio screen.

The following describes features that are available when in SiriusXM Satellite Radio mode.

Seek Up/Seek Down

- Press the “Seek arrow” button on the touchscreen for less than two seconds to seek through channels in SXM mode.
- Press and hold either “Seek arrow” button on the touchscreen for more than two seconds to bypass channels without stopping. The radio will stop at the next listenable channel once the arrow button on the touchscreen is released.

Direct Tune

- Tune directly to a SXM channel by pressing the “Tune” button on the touchscreen, and entering the desired station number.

Jump

Jump automatically tells you when Traffic & Weather for a favorite city is available, and gives you the option to switch to that channel.

- Press “Jump” to activate the feature. After listening to Traffic and Weather, press “Jump” again to return to the previous channel.

Fav

Activates the favorites menu. You can add up to 50 favorite artists or songs.

- Just press Add Fav Artist or Add Fav Song while the song is playing. You will then be alerted any time one of these songs, or works by these artists, is playing on other SiriusXM channels.

SiriusXM Parental Controls

You can skip or hide certain channels from view if you do not want access to them.

- Press the “Apps” button on the touchscreen, then the “Settings” button on the touchscreen. Next press the “Sirius Setup” button on the touchscreen, and select “Channel Skip”. Press the box next to the channel you want skipped. They will not show up in normal usage.

SiriusXM also offers the option to permanently block selected channels. Call (1-888-601-6297 for U.S. customers, 1-877-438-9677 for Canadian customers) and request the Family-Friendly Package.

Browse

Lets you browse the SiriusXM channel listing or Genre listing. Favorites, Game Zone, Weather and Jump settings also provide a way to browse the SiriusXM channel list.

Browse Sub-Menu	Sub-Menu Description
All	Shows the channel listing.
Genre	Provides a list of all genres, and lets you jump to a channel within the selected genre.
Presets	Lets you scroll the list of Preset satellite channels. Press the channel, or press Enter on the Tune knob, to go to that channel. Press the trash can icon to delete a preset. Your presets are also shown at the top of the main Satellite Radio screen.
Favorites	Lets you manage artists and songs in the Favorites list and configure Alert Settings to let you know when favorite songs or artists are playing on other channels. Also, view a list of channels airing any of your Favorites.

Browse Sub-Menu	Sub-Menu Description
Game Zone	Provides alerts when your favorite sports teams are starting a game which is being aired on other SiriusXM channels, or when their game score is announced. You can select and manage your Teams list here, and configure alerts.
Jump	Lets you select your favorite cities for Traffic & Weather information, which is used by the Jump feature on the main satellite radio screen.

Replay

Lets you replay up to 44 minutes of the content of the current SiriusXM channel.

Replay Option	Option Description
Play/Pause	Press to Pause content playback. Press Pause/Play again to resume playback.
Rewind/RW	Rewinds the channel content in steps of five seconds. Press and hold to rewind continuously, then release to begin playing content at that point.
Fast Forward/FW	Forwards the content, and works similarly to Rewind/RW. However, Fast Forward/FW can only be used when content has been previously rewound.
Replay Time	Displays the amount of time in the upper center of the screen by which your content lags the Live channel.
Live	Resumes playback of Live content at any time while replaying rewound content.

SiriusXM services require subscriptions, sold separately after the 12-month trial included with the new vehicle purchase. **If you decide to continue your service at the end of your trial subscription, the plan you choose will automatically renew and bill at then-current rates until you call SiriusXM at 1-866-635-2349 for U.S. residents and 1-888-539-7474 for Canadian residents to cancel. See SiriusXM Customer Agreement for complete terms at www.siriusxm.com for U.S. residents and www.siriusxm.ca for Canadian residents.** All fees and programming subject to change. Our satellite service is available only to those at least 18 and older in the 48 contiguous USA and D.C. Our Sirius satellite service is also available in PR (with coverage limitations). Our Internet radio service is available throughout our satellite service area and in AK and HI. © 2014 Sirius XM Radio Inc. Sirius, XM and all related marks and logos are trademarks of Sirius XM Radio Inc.

Disc Operation

Your vehicle may have a remote CD player located in the lower center console storage bin.

- CD/Disc Mode is entered by either inserting a CD/Disc or by pressing the “Media” button on the touchscreen. Once in Media Mode, select “Disc.”
- Gently insert one CD into the CD player with the CD label facing as indicated on the illustration located on the Disc player.

Seek Up/Down Buttons

- Press to seek through Disc tracks.
- Hold either button to bypass tracks without stopping.

Browse

- Press the “Browse” button on the touchscreen to scroll through and select a desired track on the Disc. Press the “Exit” button on the touchscreen if you wish to cancel the browse function.

MEDIA HUB — iPod®/USB/MP3/SD Card

There are many ways to play music from iPod®/MP3 players or USB devices through your vehicle's sound system.

- Press your “Media” button on the touchscreen to begin.

USB Port

Connect your iPod® or compatible device using a USB cable into the USB Port. USB Memory sticks with audio files can also be used. Audio from the device can be played on the vehicle's sound system while providing metadata (artist, track title, album, etc.) information on the radio display.

When connected, the iPod®/compatible USB device can be controlled using the radio or Steering Wheel Audio Controls to play, skip to the next or previous track, browse, and list the contents.

The iPod® battery charges when plugged into the USB port (if supported by the specific device).

There are also two USB Charge Only ports located on the back of the center console for rear passengers.

To route the USB/iPod® cable out of the center console, use the access cut out.

NOTE:

- When connecting your iPod® device for the first time, the system may take several minutes to read your music, depending on the number of files. For example, the system will take approximately five minutes for every 1,000 songs loaded on the device. Also during the reading process, the Shuffle and Browse functions will be disabled. This process is needed to ensure the full use of your iPod® features and only happens the first time it is connected. After the first time, the reading process of your iPod® will take considerably less time unless changes are made or new songs are added to the playlist.
- The USB port supports certain Mini, Classic, Nano, Touch, and iPhone® devices. The USB port also supports playing music from compatible external USB Mass Storage Class memory devices. Some iPod® software versions may not fully support the USB port features. Please visit Apple's website for iPod® software updates.

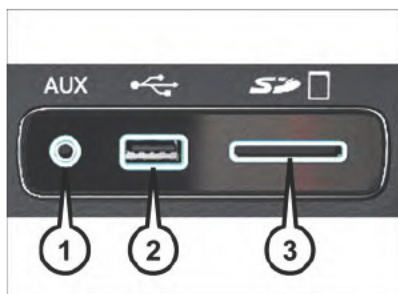

Uconnect® Media Hub

- 1 — AUX Jack
- 2 — USB Port
- 3 — SD Card Slot

Audio Jack (AUX)

The AUX allows a portable device, such as an MP3 player or an iPod®, to be plugged into the radio and utilize the vehicle's sound system, using a 3.5 mm stereo audio cable, to amplify the source and play through the vehicle speakers.

- Pressing the “AUX” button on the touchscreen will change the mode to auxiliary device if the audio jack is connected, allowing the music from your portable device to be heard through the vehicle's speakers. To activate the AUX, plug in the audio jack.
- The functions of the portable device are controlled using the device buttons. The volume may be controlled using the radio or portable device.
- To route the audio cable out of the center console, use the access cut out in the front of the console.

Bluetooth® Streaming Audio

If using a Bluetooth® - equipped device, you may also be able to stream music to your vehicle's sound system. Your connected device must be Bluetooth-compatible, and paired with your system (see Uconnect® Phone for pairing instructions).

- You can access the music from your connected Bluetooth® device by pressing the “Bluetooth®” button on the touchscreen while in Media mode.

SD Card

SD Card Mode allows you to play music that has been saved to your SD Card through your vehicle's sound system.

- You can enter SD Card Mode is by either inserting a SD Card into the SD Card slot or by pressing the “SD Card” button on the left side of the display while media mode.

For further information refer to your Radio Supplement.

iPod®/CD/AUX CONTROLS



Uconnect® 8.4A Media

- | | |
|-----------------------------|--|
| 1 — Repeat Music Track | 5 — Show Songs Currently In Cue To Be Played |
| 2 — Music Track And Time | 6 — Browse Music By |
| 3 — Shuffle Music Tracks | 7 — Music Source |
| 4 — Music Track Information | |

- The iPod®/CD/AUX controls are accessed by pressing the desired button displayed on the side of the touchscreen and choosing between Disc, AUX, iPod®, or Bluetooth®.

NOTE:

Uconnect® will usually automatically switch to the appropriate mode when something is first connected or inserted into the system.

NAVIGATION (DEALER-ACTIVATED OPTION)

Your Uconnect® 8.4A is "Navigation-Ready", and can be equipped with Navigation at an extra cost. Please see your dealer for details.

The information in the section below is only applicable if the Navigation has been activated.

Changing The Navigation Voice Prompt Volume

1. Press the “settings” button on the touchscreen.
2. In the Settings menu, press the “Guidance” button on the touchscreen.
3. In the Guidance menu, adjust the Nav Volume by pressing the “+” or “-” Nav Volume Adjustment button on the touchscreen.



Uconnect® 8.4 Navigation

- | | |
|------------------------|----------------------------------|
| 1 — Find A Destination | 5 — Repeat Route Guidance Prompt |
| 2 — View Map | 6 — Detour A Route |
| 3 — Information | 7 — Stop A Route |
| 4 — Emergency | 8 — Navigation Settings |

Finding Points Of Interest (POI)

From the main Navigation menu, press the “Where To?” button on the touchscreen, then press the “Points of Interest” button on the touchscreen.

- Select a Category and then a subcategory, if necessary.
- Select your destination and press the “Yes” button on the touchscreen.

Finding A Place By Spelling The Name

From the Main Navigation Menu press the “Where to?” button on the touchscreen, press the “Points of Interest” button on the touchscreen and then press the “Spell Name” button on the touchscreen.

- Enter the name of your destination.
- Press the “List” button on the touchscreen.
- Select your destination and press the “Yes” button on the touchscreen.

Entering A Destination Address

From the main Navigation menu press the “Where To?” button on the touchscreen, then press the “Address” button on the touchscreen.

- Follow the on-screen prompts (country, state/province, city, street) to enter the address and press the “Yes” button on the touchscreen.
- Destination entry is not available while your vehicle is in motion. However, you can also use Voice Command to enter an address while moving. See Voice Command Tips for more information.

Setting Your Home Location

Press the “Nav” button on the touchscreen in the menu bar to access the Navigation system and the Main Navigation menu.

- Press the “Where To?” button on the touchscreen, then press the “Go Home” button on the touchscreen.
- You may enter your address directly, use your current location as your home address, or choose from recently found locations.
- To delete your Home location (or other saved locations) so you can save a new Home location, press the “Where To?” button on the touchscreen from the Main Navigation menu, then press the “Go Home” button on the touchscreen, and in the Yes screen press the “Options” button on the touchscreen. In the Options menu press “Clear Home.” Set a new Home location by following the previous instructions.

Go Home

A Home location must be saved in the system. From the Main Navigation menu, press the “Where To?” button on the touchscreen, then press the “Go Home” button on the touchscreen.



Uconnect® 8.4 Map

- | | |
|-------------------------------|--------------------------------|
| 1 — Distance To Next Turn | 5 — Your Location On The Map |
| 2 — Next Turn Street | 6 — Navigation Main Menu |
| 3 — Estimated Time Of Arrival | 7 — Current Street Location |
| 4 — Zoom In And Out | 8 — Navigation Routing Options |

Your route is marked with a blue line on the map. If you depart from the original route, your route is recalculated. A speed limit icon could appear as you travel on major roadways.

Adding A Stop

To add a stop you must be navigating a route.

- Press the “Menu” button on the touchscreen to return to the Main Navigation menu.
- Press the “Where To?” button on the touchscreen, then search for the extra stop. When another location has been selected, you can choose to cancel your previous route, add as the first destination or add as the last destination.
- Press the desired selection and press the “Yes” button on the touchscreen.

Taking A Detour

To take a detour you must be navigating a route.

- Press the “Detour” button on the touchscreen.

NOTE:

If the route you are currently taking is the only reasonable option, the device might not calculate a detour.

For more information, see your Uconnect® Supplement Manual.

Uconnect® 8.4A/8.4AN VOICE RECOGNITION QUICK TIPS

Introducing Uconnect®

Start using Uconnect® Voice Recognition with these helpful quick tips. It provides the key Voice Commands and tips you need to know to control your Uconnect® 8.4AN system.

If you see the  icon on your touchscreen, you have the Uconnect® 8.4AN system. If not, you have a Uconnect® 8.4A system.



Uconnect® 8.4AN

Get Started

1. Visit UconnectPhone.com to check mobile device and feature compatibility and to find phone pairing instructions.
2. Reduce background noise. Wind and passenger conversations are examples of noise that may impact recognition.
3. Speak clearly at a normal pace and volume while facing straight ahead. The microphone is positioned on the rearview mirror and aimed at the driver.
4. Each time you give a Voice Command, you must first push either the VR or Phone button, wait until **after** the beep, then say your Voice Command.
5. You can interrupt the help message or system prompts by pushing the VR or Phone button and saying a Voice Command from current category.

All you need to control your Uconnect® system with your voice are the buttons on your steering wheel.



Uconnect® VR/Phone Buttons

- 1 — Push To Initiate Or To Answer A Phone Call, Send Or Receive A Text
- 2 — Push To Begin Radio, Media, Navigation, Apps And Climate Functions
- 3 — Push To End Call

Basic Voice Commands

The basic Voice Commands below can be given at any point while using your Uconnect® system.

Push the VR button  VR . After the beep, say:

- **Cancel** to stop a current voice session
- **Help** to hear a list of suggested Voice Commands
- **Repeat** to listen to the system prompts again

Notice the visual cues that inform you of your voice recognition system's status. Cues appear on the touchscreen.



Uconnect® 8.4A/8.4AN

Radio

Use your voice to quickly get to the AM, FM or SiriusXM™ Satellite Radio® stations you would like to hear. (Subscription or included SiriusXM™ Satellite Radio trial required.)

Push the VR button  VR . After the beep, say:

- **Tune to ninety-five-point-five FM**
- **Tune to Satellite Channel Hits 1**

TIP: At any time, if you are not sure of what to say or want to learn a Voice Command, push the VR button  VR and say "Help." The system will provide you with a list of commands.

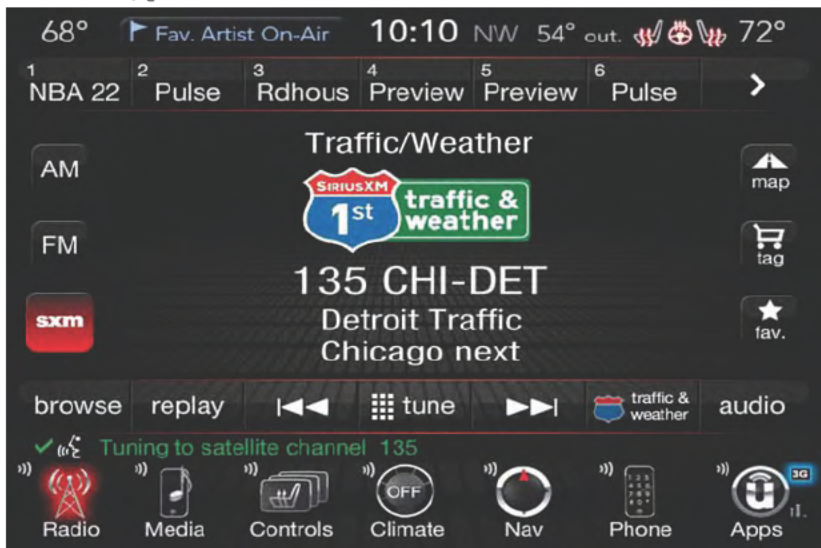

Uconnect® 8.4A/8.4AN Radio

Media

Uconnect® offers connections via USB, SD, Bluetooth® and auxiliary ports (If Equipped). Voice operation is only available for connected USB and iPod® devices. (Remote CD player optional and not available on all vehicles.)

Push the VR button  VR . After the beep, say one of the following commands and follow the prompts to switch your media source or choose an artist.

- **Change source to Bluetooth®**
- **Change source to iPod®**
- **Change source to USB**

ELECTRONICS

- **Play artist** Beethoven; **Play album** Greatest Hits; **Play song** Moonlight Sonata; **Play genre** Classical

TIP: Press the Browse button on the touchscreen to see all of the music on your iPod® or USB device. Your Voice Command must match **exactly** how the artist, album, song and genre information is displayed.



Uconnect® 8.4A/8.4AN Media

Phone

Making and answering hands-free phone calls is easy with Uconnect®. When the Phonebook button is illuminated on your touchscreen, your system is ready.

U.S. residents can visit:

- UconnectPhone.com for mobile phone compatibility and pairing instructions.

Canadian residents can visit:

- UconnectPhone.com for mobile phone compatibility and pairing instructions.

Push the Phone button  . After the beep, say one of the following commands...

- **Call** John Smith
- **Dial** 123-456-7890 and follow the system prompts
- **Redial** (call previous outgoing phone number)
- **Call back** (call previous incoming phone number)

TIP: When providing a Voice Command, push the Phone button  and say "Call," then pronounce the name **exactly** as it appears in your phone book. When a contact has multiple phone numbers, you can say "Call John Smith **work.**"



Uconnect® 8.4A/8.4AN Phone

Voice Text Reply

Uconnect® will announce **incoming** text messages. Push the Phone button  and say **Listen**. (Must have compatible mobile phone paired to Uconnect® system.)

1. Once an incoming text message is read to you, push the Phone button . After the beep, say: **Reply**.
2. Listen to the Uconnect® prompts. After the beep, repeat one of the pre-defined messages and follow the system prompts.

TIP: Your mobile phone must have the full implementation of the **Message Access Profile (MAP)** to take advantage of this feature. For details about MAP, visit UconnectPhone.com for U.S. residents. Apple iPhone® iOS6 or later supports reading **incoming** text messages only.

PRE-DEFINED VOICE TEXT REPLY RESPONSES

Yes.	Stuck in Traffic.	See you later.
No.	Start without me.	I'll be Late.
Okay.	Where are you?	I will be <number> minutes late.
Call me.	Are you there yet?	
I'll call you later.	I need directions.	See you in <number> of minutes.
I'm on my way.	Can't talk right now.	Thanks.
I'm lost.		

Climate (8.4A/8.4AN)

Too hot? Too cold? Adjust vehicle temperatures hands-free and keep everyone comfortable while you keep moving ahead. (If vehicle is equipped with climate control.)

Push the VR button  VR . After the beep, say one of the following commands:

- **Set driver temperature to 70 degrees**
- **Set passenger temperature to 70 degrees**

TIP: Voice Command for Climate may only be used to adjust the interior temperature of your vehicle. Voice Command will not work to adjust the heated seats or steering wheel (if equipped.)



Uconnect® 8.4A/8.4AN Climate

Navigation (8.4A/8.4AN)

The Uconnect® navigation feature helps you save time and become more productive when you know exactly how to get to where you want to go. (Navigation is optional on the Uconnect® 8.4A system. See your dealer to activate navigation at any time.)

1. To enter a destination, push the VR button  VR . After the beep, say:
 - For the 8.4A Uconnect® System, say: **Enter state.**
 - For the 8.4AN Uconnect® System, say: **Navigate to 800 Chrysler Drive Auburn Hills, Michigan.**
2. Then follow the system prompts.

TIP: To start a POI search, push the VR button  VR . After the beep, say "Find nearest coffee shop."







Uconnect® 8.4A/8.4AN Navigation

Uconnect® Access — If Equipped (8.4A/8.4AN)

An included trial and/or subscription is required to take advantage of the Uconnect® Access services in the next section of this guide. To register with Uconnect® Access, press the "Apps" button on the 8.4-inch touchscreen to get started. Detailed registration instructions can be found on the next page.

*Uconnect® Access is available only on equipped vehicles purchased within the continental United States, Alaska and Hawaii. Services can only be used where coverage is available; see coverage map for details.

-  9-1-1 Call
-  Remote Door Lock/Unlock
-  Remote Vehicle Start**
-  Remote Horn and Lights
-  Roadside Assistance Call

-  Theft Alarm Notification
-  Stolen Vehicle Assistance
-  Yelp® Search
-  Voice Texting
-  Wi-Fi Hotspot***

**If vehicle is equipped.

***Extra charges apply.

Register (8.4A/8.4AN)

1. Press the **"Apps"** button on the bottom of the 8.4-inch touchscreen.
2. If a pop-up message appears, press **"Register"** or go to the **"Favorite Apps"** or **"All Apps"** menu and press **"Uconnect® Registration."**
3. Read through the registration instructions. Enter and confirm your personal email address. Then press **"Send."**
4. Check your personal inbox for an email from Uconnect® Access.
5. Click on the link inside the email within **72 hours** and complete the easy online registration process to create a personal Mopar® Owner Connect account linked to your vehicle.

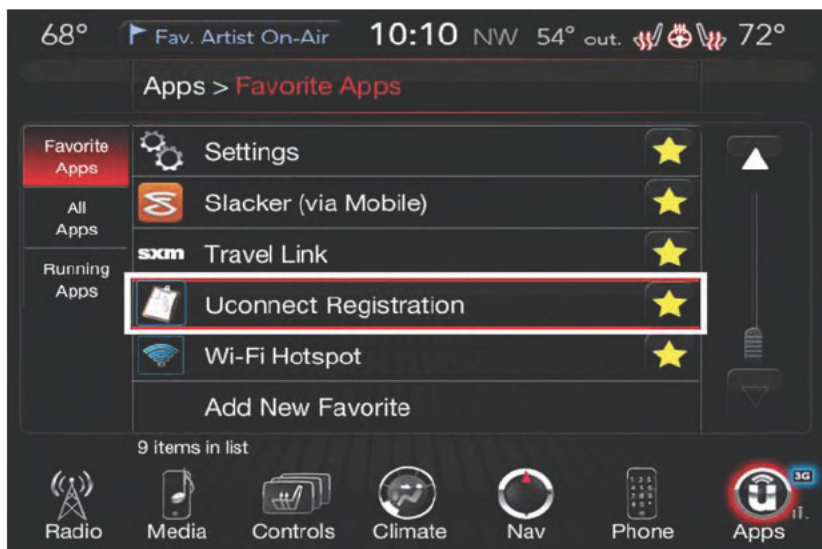

Uconnect® 8.4AN Registration

Mobile App (8.4A/8.4AN)

Securely link your mobile device to your vehicle with the Uconnect® Access App. Once you have downloaded the App, you may start your vehicle or lock it from virtually any distance. (Vehicle must be properly equipped with factory-installed Remote Start.)

Download the Uconnect® Access App to compatible Apple® or Android® mobile devices. All you need to do is:

1. After registering with Uconnect® Access, log on to your Mopar® Owner Connect account at moparownerconnect.com.
2. On the Dashboard page, enter your mobile phone number to receive a link to download the App on your mobile device. Or, go to iTunes® or Google Play and search for the Uconnect® Access App.
3. To activate the App, enter your Mopar Owner Connect user name and password and log in. Your vehicle is then connected to your mobile device.



Mobile App

Voice Texting (8.4A/8.4AN)

You must be registered with Uconnect® Access and have a compatible MAP – enabled smartphone to use your voice to send a personalized text message. (Not compatible with iPhone®.)

1. To send a message, push the Phone button . After the beep, say: “Send message to John Smith.”
2. Listen to the prompt. After the beep, dictate the message you would like to send. Wait for Uconnect® to process your message.



- The Uconnect® system will repeat your message and provide a variety of options to add to, delete, send or hear the message again. After the beep, tell Uconnect® what you'd like to do. For instance, if you're happy with your message, after the beep, say "Send."

TIP:

- Messages are limited to 140 characters.
- The Messaging button on the touchscreen must be illuminated to use the feature.

Yelp® (8.4A/8.4AN)

Once registered with Uconnect® Access, you can use your voice to search for the most popular places or things around you.

- Push the VR button  . After the beep, say: **Launch YELP®**.
- Once the YELP® home screen appears on the touchscreen, push the VR button  , then say: **YELP® search**.
- Listen to the system prompts and after the beep, tell Uconnect® the place or business that you'd like Uconnect® to find.

TIP: Once you perform a search, you can reorganize the results by selecting either the Best Match, Rating or Distance tab on the top of the touchscreen display.

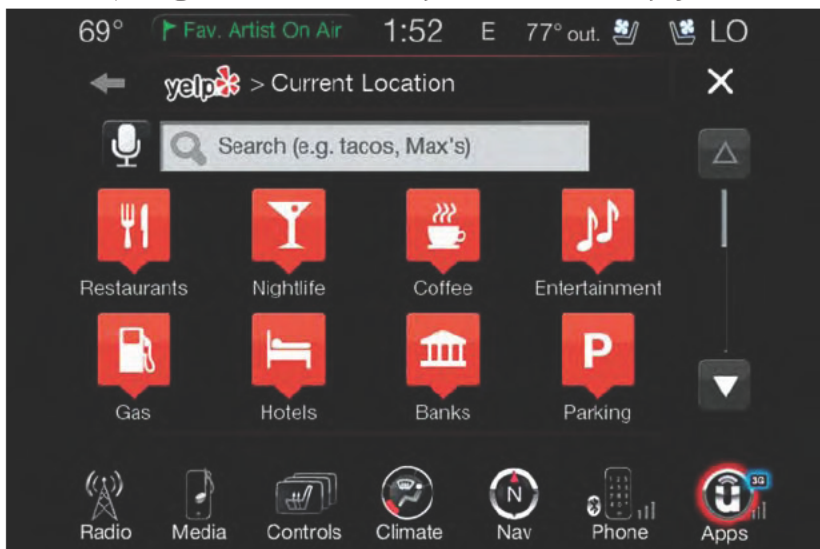

Yelp®

SiriusXM Travel Link™ (8.4A/8.4AN — US Market Only)

Need to find a gas station, view local movie listings, check a sports score or the 5 - day weather forecast? SiriusXM Travel Link™ is a suite of services that brings a wealth of information right to your Uconnect® 8.4AN system. (Not available for 8.4A system.)

Push the VR button  VR. After the beep, say one of the following commands:

- Show fuel prices
- Show 5 - day weather forecast
- Show extended weather

TIP: Traffic alerts are not accessible with Voice Command.

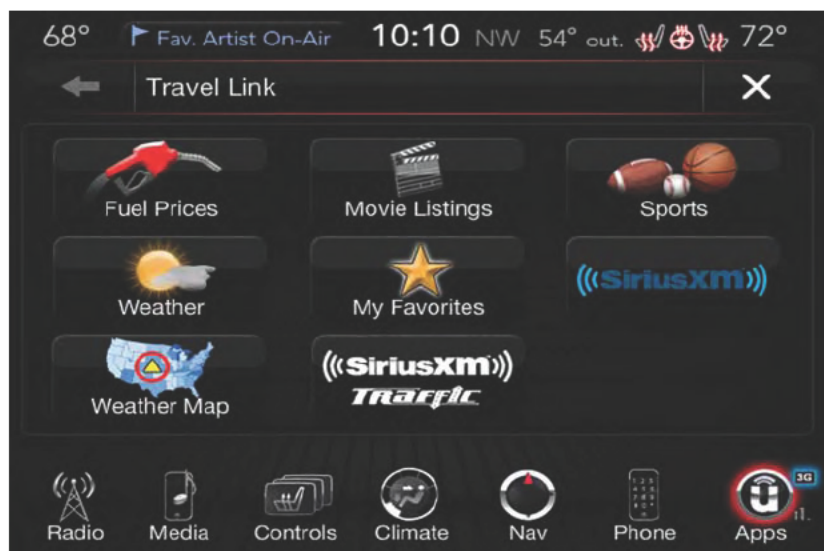

SiriusXM Travel Link™

Additional Information

© 2014 Chrysler Group LLC. All rights reserved. Mopar, Mopar Owner Connect and Uconnect are registered trademarks of Chrysler Group LLC. Android is a trademark of Google Inc. SiriusXM and all related marks and logos are trademarks of SiriusXM Radio Inc. Yelp, Yelp logo, Yelp burst and related marks are registered trademarks of Yelp.

Uconnect® System Support:

- U.S. residents visit DriveUconnect.com or call: 1-877-855-8400
- Canadian residents visit DriveUconnect.ca or call: 1-800-465-2001 (English) or 1-800-387-9983 (French)

Mon. – Fri., 7:00 am – 12:00 am, ET

Sat., 8:00 am – 10:00 pm, ET

Sun., 9:00 am – 5:00 pm, ET

Uconnect® Access Services Support 1-855-792-4241. Please have your Uconnect® Security PIN ready when you call.

Uconnect® 8.4AN

Uconnect® 8.4AN — If Equipped

At A Glance



Uconnect® 8.4AN

- | | |
|-------------------------------|---------------------------------|
| 1 — Status Bar | 6 — Uconnect® Navigation Button |
| 2 — View Small Navigation Map | 7 — Climate Button |
| 3 — HD Radio Available | 8 — Controls Button |
| 4 — Uconnect® Apps Button | 9 — Media Button |
| 5 — Uconnect® Phone Button | 10 — Radio Button |

Displaying The Time

If the time is not currently displayed on the radio or player main page:

1. Press the “Controls” button on the touchscreen or the “Apps” button on the touchscreen, then the “Settings” button on the touchscreen.
2. In the Settings list, press the “Clock” button on the touchscreen.

Setting The Time

Model 8.4AN synchronizes time automatically via GPS, so it should not require any time adjustment. If you do need to set the time manually, follow the instructions below for Model 8.4A.

1. Turn the unit on, then press the “Time Display” at the top of the screen. Press “Yes.”

NOTE:

If the time is not displayed at the top of the screen, press the “Controls” or the “Apps” button on the touchscreen, then the “Settings” button on the touchscreen. In the Settings screen, press the “Clock” button on the touchscreen.

2. Press “+” or “-” next to Set Time Hours and Set Time Minutes to adjust the time.
3. If these features are not available, uncheck the Sync with GPS box.
4. Press “X” to save your settings and exit out of the Clock Setting screen.

Audio Settings

To adjust the Audio settings:

1. Press the “Media” or “Radio” button on the touchscreen.
2. Press the “Audio” button on the touchscreen to activate the Audio settings screen to adjust Balance/Fade, Equalizer and Speed Adjusted Volume.
3. You can return to the Radio screen by pressing the “X” located at the top right.

Balance/Fade

To adjust the Balance/Fade settings:

1. Press the “Media” or “Radio” button on the touchscreen.
2. Press the “Audio” button on the touchscreen to activate the Audio settings screen to adjust Balance/Fade, Equalizer and Speed Adjusted Volume.
3. Press the “Balance/Fade” button on the touchscreen to Balance audio between the front speakers or fade the audio between the rear and front speakers.
4. Pressing the “Front,” “Rear,” “Left” or “Right” button on the touchscreens or press and drag the Speaker Icon to adjust the Balance/Fade.

Equalizer

To adjust the equalizer settings:

1. Press the “Media” or “Radio” button on the touchscreen.
2. Press the “Audio” button on the touchscreen to activate the Audio settings screen to adjust Balance/Fade, Equalizer and Speed Adjusted Volume.
3. Press the “Equalizer” button on the touchscreen to activate the Equalizer screen.
4. Press the “+” or “-” button on the touchscreens, or by pressing and dragging over the “level bar” for each of the equalizer bands. The level value, which spans between plus or minus 9, is displayed at the bottom of each of the Bands.

Speed Adjusted Volume

To adjust the speed adjusted volume settings:

1. Press the “Media” or “Radio” button on the touchscreen.

2. Press the “Audio” button on the touchscreen to activate the Audio settings screen to adjust Balance/Fade, Equalizer and Speed Adjusted Volume.
3. Press the “Speed Adjusted Volume” button on the touchscreen to activate the Speed Adjusted Volume screen. The Speed Adjusted Volume is adjusted by pressing the “volume level” indicator. This alters the automatic adjustment of the audio volume with variation to vehicle speed.

Surround Sound

To turn surround sound On/Off:

1. Press the “Media” or “Radio” button on the touchscreen.
2. Press the “Audio” button on the touchscreen to activate the Audio settings screen to adjust Balance/Fade, Equalizer and Speed Adjusted Volume.
3. Press the “Surround Sound” button on the touchscreen, select On or Off followed by pressing the “back arrow” button on the touchscreen. When this feature is activated, it provides simulated surround sound mode.

RADIO



Uconnect® 8.4AN Radio

- | | |
|----------------------------------|------------------------------------|
| 1 — Radio Station Presets | 6 — Direct Tune To A Radio Station |
| 2 — Toggle Radio Station Presets | 7 — Seek Down |
| 3 — HD Radio Available | 8 — Browse And Manage |
| 4 — Audio Settings | 9 — Choose Radio Band |
| 5 — Seek Up | |

To access the Radio mode:

- Press the “Radio” button at the lower left of the touchscreen.

Selecting Radio Stations

- Press the desired radio band (AM, FM or SXM) button on the touchscreen.

Seek Up ►► / Seek Down ◀◀

- Press the “Seek arrow” buttons on the touchscreen for less than two seconds to seek through radio stations.
- Press and hold either “Seek arrow” button on the touchscreen for more than two seconds to bypass stations without stopping. The radio will stop at the next listenable station once the “arrow” button on the touchscreen is released.

Direct Tune

- Tune directly to a radio station by pressing the “Tune” button on the screen, and entering the desired station number.

Store Radio Presets

Your radio can store 36 total preset stations, 12 presets per band (AM, FM and SXM). They are shown at the top of your radio screen.

- To see the 12 preset stations per band, press the “arrow” button on the touchscreen at the top right of the screen to toggle between the two sets of six presets.
- To set a station into memory press and hold the desired numbered button on the touchscreen for more than two seconds or until you hear a confirmation beep.

HD Radio

HD Radio technology (available on Uconnect® 8.4AN) allows broadcasters to transmit a high-quality digital signal.

With an HD radio receiver, the listener is provided with a clear sound that enhances the listening experience. HD radio can also transmit data such as song title or artist.

SiriusXM Premier Over 160 Channels

Get every channel available on your satellite radio, and enjoy all you want, all in one place. Hear commercial-free music plus sports, news, talk and entertainment. Get all the premium programming, including Howard Stern, every NFL game, Oprah Radio®, every MLB® and NHL® game, every NASCAR® race and more. And get 20+ Xtra channels, including SiriusXM Latino, a selection of channels dedicated to Spanish language programming.

- To access SiriusXM Satellite Radio, press the “SXM” button on the touchscreen on the main Radio screen.

The following describes features that are available when in SiriusXM Satellite Radio mode.

Seek Up/Seek Down

- Press the “Seek arrow” button on the touchscreen for less than two seconds to seek through channels in SXM mode.
- Press and hold either “Seek arrow” button on the touchscreen for more than two seconds to bypass channels without stopping. The radio will stop at the next listenable channel once the arrow button on the touchscreen is released.

Direct Tune

- Tune directly to a SXM channel by pressing the “Tune” button on the touchscreen, and entering the desired station number.

Jump

Jump automatically tells you when Traffic & Weather for a favorite city is available, and gives you the option to switch to that channel.

- Press “Jump” to activate the feature. After listening to Traffic and Weather, press “Jump” again to return to the previous channel.

Fav

Activates the favorites menu. You can add up to 50 favorite artists or songs.

- Just press Add Fav Artist or Add Fav Song while the song is playing. You will then be alerted any time one of these songs, or works by these artists, is playing on other SiriusXM channels.

SiriusXM Parental Controls

You can skip or hide certain channels from view if you do not want access to them.

- Press the “Apps” button on the touchscreen, then the “Settings” button on the touchscreen. Next press the “Sirius Setup” button on the touchscreen, and select “Channel Skip”. Press the box next to the channel you want skipped. They will not show up in normal usage.

SiriusXM also offers the option to permanently block selected channels. Call (1-888-601-6297 for U.S. customers, 1-877-438-9677 for Canadian customers) and request the Family-Friendly Package.

Browse

Lets you browse the SiriusXM channel listing or Genre listing. Favorites, Game Zone, Weather and Jump settings also provide a way to browse the SiriusXM channel list.

Browse Sub-Menu	Sub-Menu Description
All	Shows the channel listing.
Genre	Provides a list of all genres, and lets you jump to a channel within the selected genre.
Presets	Lets you scroll the list of Preset satellite channels. Press the channel, or press Enter on the Tune knob, to go to that channel. Press the trash can icon to delete a preset. Your presets are also shown at the top of the main Satellite Radio screen.
Favorites	Lets you manage artists and songs in the Favorites list and configure Alert Settings to let you know when favorite songs or artists are playing on other channels. Also, view a list of channels airing any of your Favorites.
Game Zone	Provides alerts when your favorite sports teams are starting a game which is being aired on other SiriusXM channels, or when their game score is announced. You can select and manage your Teams list here, and configure alerts.
Jump	Lets you select your favorite cities for Traffic & Weather information, which is used by the Jump feature on the main satellite radio screen.

Replay

Lets you replay up to 44 minutes of the content of the current SiriusXM channel.

Replay Option	Option Description
Play/Pause	Press to Pause content playback. Press Pause/Play again to resume playback.
Rewind/RW	Rewinds the channel content in steps of five seconds. Press and hold to rewind continuously, then release to begin playing content at that point.
Fast Forward/FW	Forwards the content, and works similarly to Rewind/RW. However, Fast Forward/FW can only be used when content has been previously rewound.
Replay Time	Displays the amount of time in the upper center of the screen by which your content lags the Live channel.
Live	Resumes playback of Live content at any time while replaying rewound content.

SiriusXM services require subscriptions, sold separately after the 12-month trial included with the new vehicle purchase. **If you decide to continue your service at the end of your trial subscription, the plan you choose will automatically renew and bill at then-current rates until you call SiriusXM at 1-866-635-2349 for U.S. residents and 1-888-539-7474 for Canadian residents to cancel. See SiriusXM Customer Agreement for complete terms at www.siriusxm.com for U.S. residents and www.siriusxm.ca for Canadian residents.** All fees and programming subject to change. Our satellite service is available only to those at least 18 and older in the 48 contiguous USA and D.C. Our Sirius satellite service is also available in PR (with coverage limitations). Our Internet radio service is available throughout our satellite service area and in AK and HI. © 2014 Sirius XM Radio Inc. Sirius, XM and all related marks and logos are trademarks of Sirius XM Radio Inc.

Disc Operation

Your vehicle may have a remote CD player located in the lower center console storage bin.

- CD/Disc Mode is entered by either inserting a CD/Disc or by pressing the “Media” button on the touchscreen. Once in Media Mode, select “Disc.”
- Gently insert one CD into the CD player with the CD label facing as indicated on the illustration located on the Disc player.

Seek Up/Down Buttons

- Press to seek through Disc tracks.
- Hold either button to bypass tracks without stopping.

Browse

- Press the “Browse” button on the touchscreen to scroll through and select a desired track on the Disc. Press the “Exit” button on the touchscreen if you wish to cancel the browse function.

MEDIA HUB — iPod®/USB/MP3/SD Card

There are many ways to play music from iPod®/MP3 players, SD card, or USB devices through your vehicle's sound system.

- Press your “Media” button on the touchscreen to begin.

USB Port

Connect your iPod® or compatible device using a USB cable into the USB Port. USB Memory sticks with audio files can also be used. Audio from the device can be played on the vehicle's sound system while providing metadata (artist, track title, album, etc.) information on the radio display.

When connected, the iPod®/compatible USB device can be controlled using the radio or Steering Wheel Audio Controls to play, skip to the next or previous track, browse, and list the contents.

The iPod® battery charges when plugged into the USB port (if supported by the specific device.)

To route the USB/iPod® cable out of the center console, use the access cut out.

NOTE:

- When connecting your iPod® device for the first time, the system may take several minutes to read your music, depending on the number of files. For example, the system will take approximately five minutes for every 1,000 songs loaded on the device. Also during the reading process, the Shuffle and Browse functions will be disabled. This process is needed to ensure the full use of your iPod® features and only happens the first time it is connected. After the first time, the reading process of your iPod® will take considerably less time unless changes are made or new songs are added to the playlist.
- The USB port supports certain Mini, Classic, Nano, Touch, and iPhone® devices. The USB port also supports playing music from compatible external USB Mass Storage Class memory devices. Some iPod® software versions may not fully support the USB port features. Please visit Apple's website for iPod® software updates.

Audio Jack (AUX)

The AUX allows a portable device, such as an MP3 player or an iPod®, to be plugged into the radio and utilize the vehicle's sound system, using a 3.5 mm audio cable, to amplify the source and play through the vehicle speakers.

- Pressing the “AUX” button on the touchscreen will change the mode to auxiliary device if the audio jack is connected, allowing the music from your portable device to be heard through the vehicle's speakers. In order to activate the AUX, plug in the audio jack.
- The functions of the portable device are controlled using the device buttons. The volume may be controlled using the radio or portable device.
- To route the audio cable out of the center console, use the access cut out in the front of the console.

Bluetooth® Streaming Audio

If using a Bluetooth® - equipped device, you may also be able to stream music to your vehicle's sound system. Your connected device must be Bluetooth-compatible, and paired with your system (see Uconnect® Phone for pairing instructions).

- You can access the music from your connected Bluetooth® device by pressing the "Bluetooth®" button on the touchscreen while in Media mode.

SD Card

SD Card Mode allows you to play music that has been saved to your SD Card through your vehicle's sound system.

- You can enter SD Card Mode is by either inserting a SD Card into the SD Card slot or press the "SD Card" button on the left side of the display while media mode.

For further information refer to your Radio Supplement.

iPod®/CD/AUX CONTROLS

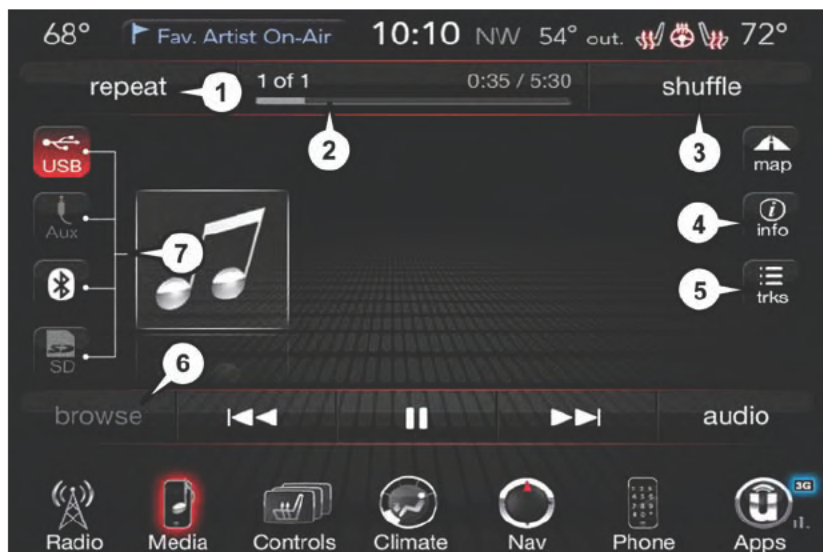

Uconnect® 8.4AN Media

- | | |
|-----------------------------|--|
| 1 — Repeat Music Track | 5 — Show Songs Currently In Cue To Be Played |
| 2 — Music Track And Time | 6 — Browse Music By |
| 3 — Shuffle Music Tracks | 7 — Music Source |
| 4 — Music Track Information | |

- The iPod®/CD/AUX controls are accessed by pressing the desired button displayed on the side of the touchscreen and choosing between Disc, AUX, iPod®, or Bluetooth®.

NOTE:

Uconnect® will usually automatically switch to the appropriate mode when something is first connected or inserted into the system.

NAVIGATION

Press the “Nav” button on the touchscreen in the menu bar to access the Navigation system.

Changing The Navigation Voice Prompt Volume

1. Press the “Settings” button on the touchscreen.
2. In the Settings menu, press the “Guidance” button on the touchscreen.
3. In the Guidance menu, adjust the Nav Volume by pressing the + or – Nav Volume Adjustment buttons on the touchscreen.



Uconnect® 8.4AN Navigation

- 1 — Find A Destination
- 2 — View Map
- 3 — Information
- 4 — Emergency

- 5 — Repeat Route Guidance Prompt
- 6 — Detour A Route
- 7 — Stop A Route
- 8 — Navigation Settings

Finding Points Of Interest (POI)

From the main Navigation menu, press the “Where To?” button on the touchscreen, then press the “Points” of Interest button on the touchscreen.

- Select a Category and then a subcategory, if necessary.
- Select your destination and press the “Yes” button on the touchscreen.

Finding A Place By Spelling The Name

From the Main Navigation Menu, press the “Where to?” button on the touchscreen, press the “Points of Interest” button on the touchscreen, press the “Spell Name” button on the touchscreen.

- Enter the name of your destination.
- Press the “List” button on the touchscreen.
- Select your destination and press the “Yes” button on the touchscreen.

Entering A Destination Address

From the main Navigation menu press the “Where To?” button on the touchscreen, then press the “Address” button on the touchscreen.

- Follow the on-screen prompts (country, state/province, city, street) to enter the address and press the “Yes” button on the touchscreen.
- Destination entry is not available while your vehicle is in motion. However, you can also use Voice Command to enter an address while moving. See Voice Command Tips for more information.

Setting Your Home Location

Press the “NAV” button on the touchscreen in the menu bar to access the Navigation system and the Main Navigation menu.

- Press the “Where To?” button on the touchscreen, then press the “Go Home” button on the touchscreen.
- You may enter your address directly, use your current location as your home address, or choose from recently found locations.
- To delete your Home location (or other saved locations) so you can save a new Home location, press the “Where To?” button on the touchscreen from the Main Navigation menu, then press the “Go Home” button, and in the Yes screen press the “Options” button on the touchscreen. In the Options menu press the “Clear Home” button on the touchscreen. Set a new Home location by following the previous instructions.

Go Home

A Home location must be saved in the system. From the Main Navigation menu, press the “Where To?” button on the touchscreen, then press the “Go Home” button on the touchscreen.



Uconnect@ 8.4AN Map

- | | |
|-------------------------------|--------------------------------|
| 1 — Distance To Next Turn | 5 — Your Location On The Map |
| 2 — Next Turn Street | 6 — Navigation Main Menu |
| 3 — Estimated Time Of Arrival | 7 — Current Street Location |
| 4 — Zoom In And Out | 8 — Navigation Routing Options |

Your route is marked with a blue line on the map. If you depart from the original route, your route is recalculated. A speed limit icon could appear as you travel on major roadways.

Adding A Stop

To add a stop you must be navigating a route.

- Press the “Menu” button on the touchscreen to return to the Main Navigation menu.
- Press the “Where To?” button on the touchscreen, then search for the extra stop. When another location has been selected, you can choose to cancel your previous route, add as the first destination or add as the last destination.
- Press the desired selection and press the “Yes” button on the touchscreen.

Taking A Detour

To take a detour you must be navigating a route.

- Press the “Detour” button on the touchscreen.

NOTE:

- If the route you are currently taking is the only reasonable option, the device might not calculate a detour.
- For more information, see your Uconnect® Supplement Manual.

SiriusXM TRAFFIC (US Market Only)

Don't Drive Through Traffic. Drive Around It.

Avoid congestion before you reach it. By enhancing your vehicle's navigation system with the ability to see detailed traffic information, you can pinpoint traffic incidents, determine average traffic speed and estimate travel time along your route. Since the service is integrated with a vehicle's navigation system, SiriusXM Traffic can help drivers pick the fastest route based on traffic conditions.

- Detailed information on traffic speed, accidents, construction, and road closings.
- Traffic information from multiple sources, including police and emergency services, cameras and road sensors.
- Coast-to-coast delivery of traffic information.
- View conditions for points along your route and beyond. Available in over 130 markets.

SiriusXM TRAVEL LINK (US Market Only)

In addition to delivering over 130 channels of the best sports, entertainment, talk, and commercial-free music, SiriusXM offers premium data services that work in conjunction with compatible navigation systems. SiriusXM Travel Link brings a wealth of useful information into your vehicle and right to your fingertips.

- **Fuel Prices** — Check local gas and diesel prices in your area and route to the station of your choice.
- **Movie Listings** — Check local movie theatres and listings in your area and route to the theater of your choice.
- **Sports Scores** — In-game and final scores as well as weekly schedules.
- **Weather** — Check variety of local and national weather information from radar maps to current and 5-day forecast.

SiriusXM Travel Link feature is completely integrated into your vehicle. A few minutes after you start your vehicle, Travel Link information arrives and updates in the background. You can access the information whenever you like, with no waiting.

To access SiriusXM Travel Link, press “Apps” button on the touchscreen, then press the “SiriusXM Travel Link” button on the touchscreen.

NOTE:

SiriusXM Travel Link requires a subscription, sold separately after the five (5) year trial subscription included with your vehicle purchase.

SiriusXM Travel Link is only available in the United States.

Fuel Prices	Check local gas and diesel prices in your area and route to the station of your choice.
Movie Listings	Check local movie theatres and listings in your area and route to the theater of your choice.
Sports Scores	In-game and final scores as well as weekly schedules.
Weather	Check variety of local and national weather information from radar maps to current and 5-day forecast.

Uconnect® PHONE

Uconnect® Phone (Bluetooth® Hands Free Calling)



Uconnect® 5.0 Phone Menu

- | | |
|--|--|
| 1 — Call/Redial/Hold | 7 — Uconnect® Phone Settings Menu |
| 2 — Mobile Phone Signal Strength | 8 — Text Messaging |
| 3 — Currently Paired Mobile Phone | 9 — Direct Dial Pad |
| 4 — Mobile Phone Battery Life | 10 — Recent Call Log |
| 5 — Mute Microphone | 11 — Browse Phone Book
(Contains 9-1-1) |
| 6 — Transfer To/From Uconnect®
System | 12 — End Call |



Uconnect® 8.4A/8.4AN Phone Menu

- | | |
|--|--|
| 1 — Favorite Contacts | 11 — Recent Call Log |
| 2 — Mobile Phone Battery Life | 12 — Browse Phone Book Entries
(Contains 9-1-1) |
| 3 — Currently Paired Mobile Phone | 13 — End Call |
| 4 — Mobile Phone Signal Strength | 14 — Call/Redial/Hold |
| 5 — Mute Microphone | * — Conference call feature only avail-
able on GSM mobile devices |
| 6 — Transfer To/From Uconnect®
System | ** — Text messaging feature not avail-
able on all mobile phones (requires
Bluetooth® MAP profile) |
| 7 — Conference Call* | |
| 8 — Manage Paired Mobile Phones | |
| 9 — Text Messaging** | |
| 10 — Direct Dial Pad | |

The Uconnect® Phone feature enables you to place and receive hands-free mobile phone calls. Drivers can also place mobile phone calls using their voice or by using the buttons on the touchscreen (see Voice Command section).

The hands-free calling feature is made possible through Bluetooth® technology — the global standard that enables different electronic devices to connect to each other wirelessly.

If the Uconnect® Phone Button  exists on your steering wheel, you then have the Uconnect® Phone features.

Refer to the **Understand The Features Of Your Vehicle** section of your vehicle's Owner's Manual on the DVD for further details.

NOTE:

- The Uconnect® Phone requires a mobile phone equipped with the Bluetooth® Hands-Free Profile, Version 1.0 or higher.
- Most mobile phones/devices are compatible with the Uconnect® system, however some mobile phones/devices may not be equipped with all of the required features to utilize all of the Uconnect® system features.
- For Uconnect® Customer Care:
 - U.S. residents visit UconnectPhone.com or call 1-877-855-8400.
 - Canadian Residents visit UconnectPhone.com or call, 1-800-465-2001 (English) or 1-800-387-9983 (French).

Pairing (Wirelessly Connecting) Your Mobile Phone To The Uconnect® System

Mobile phone pairing is the process of establishing a wireless connection between a cellular phone and the Uconnect system.

NOTE:

- To use the Uconnect® Phone feature, you first must determine if your mobile phone and software are compatible with the Uconnect® system. Please visit UconnectPhone.com for complete mobile phone compatibility information.
- Mobile phone pairing is not available while the vehicle is in motion.
- A maximum of 10 mobile phones can be paired to the Uconnect® system.

Start Pairing Procedure On The Radio

Uconnect® 5.0:

1. Place the ignition in the ACC or ON position
2. Press the "Phone" button
3. Select "Settings"
4. Select "Paired Phones"
5. Select "Add device"
 - Uconnect® Phone will display an "In progress" screen while the system is connecting.



Uconnect® 5.0

Uconnect® 8.4A, 8.4AN:

1. Place the ignition in the ACC or ON position
2. Press the "Phone" button in the Menu Bar on the touchscreen
3. Select "Settings"
4. Select "Paired Phones"
5. Select "Add device"
 - Uconnect® Phone will display an "In progress" screen while the system is connecting.

**Uconnect® 8.4A & 8.4AN****Pair Your iPhone®:**

To search for available devices on your Bluetooth® enabled iPhone®:

1. Press the Settings button
2. Select Bluetooth®
 - Ensure the Bluetooth® feature is enabled. Once enabled, the mobile phone will begin to search for Bluetooth® connections.
3. When your mobile phone finds the Uconnect® system, select "Uconnect".

**Bluetooth® On/Uconnect Device****Complete The iPhone® Pairing Procedure:**

1. When prompted on the mobile phone, accept the connection request from Uconnect® Phone.

NOTE:

Some mobile phones will require you to enter the PIN number.

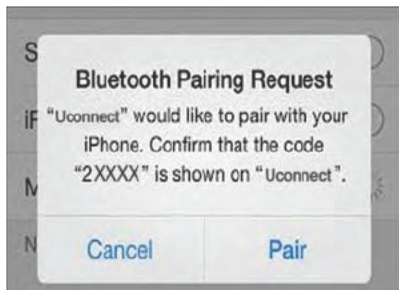
**Pairing Request**

Select The iPhone's Priority Level

When the pairing process has successfully completed, the system will prompt you to choose whether or not this is your favorite mobile phone. Selecting "Yes" will make this mobile phone the highest priority. This mobile phone will take precedence over other paired mobile phones within range and will connect to the Uconnect system automatically when entering the vehicle. Only one mobile phone and/or one Bluetooth audio device can be connected to the Uconnect® system at a time. If "No" is selected, simply select "Uconnect" from the mobile phone/audio device Bluetooth screen, and the Uconnect system will reconnect to the Bluetooth device.

Pair Your Android Device:

- To search for available devices on your Bluetooth® enabled Android Device:

1. Push the Menu button.
2. Select Settings
3. Select Connections
4. Turn Bluetooth® setting to "On".

- Ensure the Bluetooth® feature is enabled. Once enabled, the mobile phone will begin to search for Bluetooth® connections.



Uconnect® Device

5. Once your mobile phone finds the Uconnect® system, select "Uconnect".
- You may be prompted by your mobile phone to download the phonebook, check "Do Not Ask Again" to automatically download the phonebook. This is so you can make calls by saying the name of your contact.

Complete The Android Pairing Procedure:

1. Confirm the passkey shown on the mobile phone matches the passkey shown on the Uconnect system then accept the Bluetooth® pairing request.

NOTE:

Some mobile phones require the PIN to be entered manually, enter the PIN number shown on the Uconnect® screen.

Select The Android Mobile Phone's Priority Level

When the pairing process has successfully completed, the system will prompt you to choose whether or not this is your favorite mobile phone. Selecting "Yes" will make this mobile phone the highest priority. This

mobile phone will take precedence over other paired mobile phones within range and will connect to the Uconnect system automatically when entering the vehicle. Only one mobile phone and/or one Bluetooth audio device can be connected to the Uconnect® system at a time. If "No" is selected, simply select "Uconnect" from the mobile phone/audio device Bluetooth screen, and the Uconnect system will reconnect to the Bluetooth device.

You are now ready to make hands-free calls. Press the Uconnect® "Phone" button  on your steering wheel to begin.

NOTE:

Refer to UconnectPhone.com website for additional information on mobile phone pairing and for a list of compatible phones.

Making A Phone Call

- Push the Uconnect® Phone button .
- Say "dial" then the number (or "call" then the name as listed in your phone; see Phonebook) after the BEEP.

NOTE:

You can also initiate a call by using the touchscreen on the Uconnect® Phone main screen.

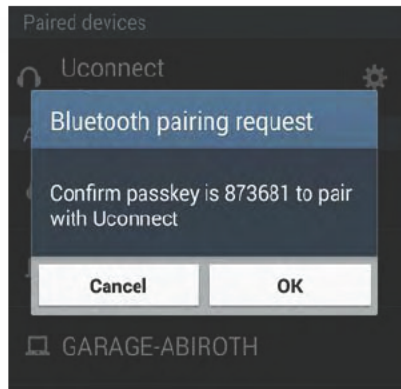

Common Phone Commands (Examples)

- "Call John Smith"
- "Call John Smith mobile"
- "Dial 1 248 555 1212"
- "Redial"



Pairing Request

Receiving A Call – Accept (And End)

- When an incoming call rings/is announced on Uconnect®, push the Phone button  .
- To end a call, push the Hang Up or Phone button  .

Mute (Or Unmute) Microphone During Call

- During a call, press the “Mute” button on the Phone main screen to mute and unmute the call.

Transfer Ongoing Call Between Handset And Vehicle

- During an on-going call, press the “Transfer” button on the Phone main screen to transfer an on-going call between handset and vehicle.

Phonebook

The Uconnect® system will automatically sync your phonebook from your paired phone, if this feature is supported by your phone. Phonebook contacts are updated each time that the phone is connected. If your phone book entries do not appear, check the settings on your phone. Some phones require you to enable this feature manually.

- Your phonebook can be browsed on the Uconnect® system touchscreen, but editing can only be done on your phone. To browse, press the “Phone” button on the touchscreen, then the “Phonebook” button on the touchscreen.

Favorite phonebook entries can be saved as Favorites for quicker access. Favorites are shown at the top of the main phone screen.

Voice Command Tips

- Speaking complete names (i.e; Call John Doe vs. Call John) will result in greater system accuracy.
- You can “link” commands together for faster results. Say “Call John Doe, mobile,” for example.
- If you are listening to available voice command options, you do not have to listen to the entire list. When you hear the command that you need, push the  VR button on the steering wheel, wait for the beep and say your command.

Changing The Volume

- Start a dialogue by pushing the Phone button  , then say a command for example - “Help”.
- Use the radio VOLUME/MUTE rotary knob to adjust the volume to a comfortable level while the Uconnect® system is speaking. Please note the volume setting for Uconnect® is different than the audio system.

NOTE:

To access help, push the Uconnect® Phone  button on the steering wheel and say “help.” Press the display or press either the Phone  or VR  VR button and say “cancel” to cancel the help session.

Incoming Text Messages

After pairing your Uconnect® system with a Bluetooth® enabled mobile device with the Message Access Profile (MAP), the Uconnect® system can announce a new incoming text message and read it to you over the vehicle's audio system.

NOTE:

Only incoming text messages received during the current ignition cycle can be viewed/read.

To enable incoming text messaging:

iPhone®

1. Press the settings button on the mobile phone.
2. Select Bluetooth®.
 - Ensure Bluetooth is enabled, and the mobile phone is paired to the Uconnect® system.
3. Select ⓘ located under DEVICES next to Uconnect.
4. Turn "Show Notifications" to On.

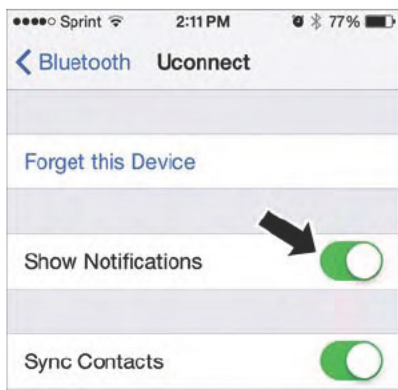

Enable iPhone® Incoming Text Messages

Android Devices

1. Push the Menu button on the mobile phone.
2. Select Settings.
3. Select Connections.
4. Turn "Show Notifications" to On.
 - A pop up will appear asking you to accept a request for permission to connect to your messages. Select "Don't ask again" and press OK.

NOTE:

All incoming text messages received during the current ignition cycle will be deleted from the Uconnect® system when the ignition is turned to the Off position.

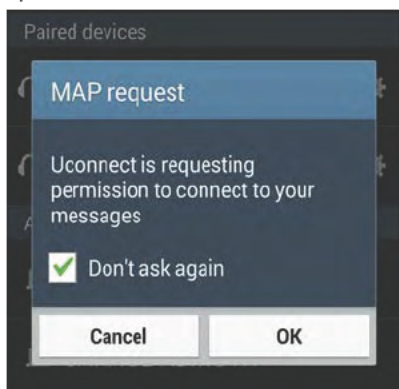

Enable Android Device Incoming Text Messages

Voice Text Reply (Not Compatible With iPhone®)

NOTE:

Voice texting reply and voice texting features require a compatible mobile device enabled with Bluetooth® Message Access Profile (MAP). iPhone®, and some other smartphones, may not entirely support Bluetooth® MAP. Visit UconnectPhone.com for the latest system and device compatibility.

- Due to the extremely large number of mobile phone manufacturers, your mobile device may not be listed. For further assistance, contact Uconnect Customer Care @ 1-877-855-8400 for U.S. residents or, 1-800-465-2001 (English) / 1-800-387-9983 (French) for Canadian residents.

Once your Uconnect® system is paired with a compatible mobile device, the system can announce a new incoming text message, and read it to you over the vehicle audio system. You can reply to the message using Voice Recognition by selecting, or saying, one of the 18 pre-defined messages.

Here's How:

- Push the Uconnect® Phone button  and wait for the beep, then say “reply.” Uconnect® will give the following prompt: “Please say the message you would like to send.” Wait for the beep and say one of the pre-defined messages. (If you are not sure, you can say “help” at any time). Uconnect® will then read the pre-defined messages allowed. As soon as you hear the message you would like to send, you can interrupt the list of prompts by pushing the Uconnect® Phone button and saying the phrase. Uconnect® will confirm the message by reading it back to you. Push the Phone button and say “Send.”

PRE-DEFINED VOICE TEXT REPLY RESPONSES

Yes.	Stuck in Traffic.	See you later.
No.	Start without me.	I'll be Late.
Okay.	Where are you?	I will be <5, 10, 15,...etc.> minutes late.
Call me.	Are you there yet?	
I'll call you later.	I need directions.	See you in <5, 10, 15,...etc.> of minutes.
I'm on my way.	Can't talk right now.	
I'm lost.		Thanks.

Want to dictate a personal message?

- You must first register with Uconnect® Access (U.S. residents only) to take advantage of a new, cloud-based Voice Texting service, an enhancement to Voice Text Reply (Uconnect® 8.4A/8.4AN systems ONLY).

Helpful Tips And Common Questions To Improve Bluetooth® Performance With Your Uconnect® System

Mobile Phone won't reconnect to system after pairing:

- Set mobile phone to auto-connect or trusted device in mobile phone Bluetooth® settings (Blackberry devices).
- Perform a factory reset on your mobile phone. Refer to your mobile phone manufacturer or cellular provider for instructions.
- Many mobile phones do not automatically reconnect after being restarted (hard reboot). Your mobile phone can still be connected manually. Close all applications that may be operating (refer to mobile phone manufacturer's instructions), and follow “Pairing (Wirelessly Connecting) Your Mobile Phone To The Uconnect® System”.

Mobile Phone won't pair to system:

- Perform a hard reset in the mobile phone by removing the battery (if removable — see your mobile phone's owner manual).
- Delete pairing history in mobile phone and Uconnect system; usually found in phone's Bluetooth® connection settings.
- Verify you are selecting “Uconnect” in the discovered Bluetooth® devices on your mobile phone.
- If your vehicle system generates a pin code the default is 0000.

Mobile Phonebook didn't download:

- Check "Do not ask again," then accept the "phonebook download" request on your mobile phone.
- Up to 5,000 contact names with four numbers per contact will transfer to the Uconnect® 8.4A/8.4AN system phonebook.
- Up to 2,000 contact names with six numbers per contact will transfer to the Uconnect® 5.0 system phonebook.

Text messaging won't work:

- Check "Do not ask again," then accept the "connect to your messages" request on your mobile phone.
- Verify that your mobile phone has the Bluetooth® feature (Message Access Profile).

Can't make a conference call:

- CDMA (Code-Division Multiple Access) carriers do not support conference calling. Refer to your mobile phone user's manual for further information.

Making calls while connected to AUX:

- Plugging in your mobile phone to AUX while connected to Bluetooth® will disable Hands-Free Calling. Do not make calls while your mobile phone is plugged into the AUX jack.

STEERING WHEEL AUDIO CONTROLS

The steering wheel audio controls are located on the rear surface of the steering wheel.

Right Switch

- Push the switch up or down to increase or decrease the volume.
- Push the button in the center to change modes AM/FM/CD/SXM.

Left Switch

- Push the switch up or down to search for the next listenable station or select the next or previous CD track.
- Push the button in the center to select the next preset station (radio) or to change CDs if equipped with a CD Changer.



Steering Wheel Controls

DRIVER INFORMATION DISPLAY (DID)

The DID features a driver interactive display that is located in the instrument cluster. Pushing the controls on the left side of the steering wheel allows the driver to select vehicle information and Personal Settings. For additional information, refer to “Programmable Features” in this guide.

- Push the UP \triangle button to scroll upward through the main menus (Speedometer, MPH/km/h, Vehicle Info, Driver Assist, Fuel Economy, Trip, Audio, Stored Messages, and Screen Set Up).
- Push the DOWN ∇ button to scroll downward through the main menu and submenus.
- Push the RIGHT \triangleright button to access the information screens or sub-menu screens of a main menu item.
- Push the BACK/LEFT \triangleleft button to access the information screens or sub-menu screens of a main menu item.
- Push the **OK** button to access/select the information screens or sub-menu screens of a main menu item. Push and hold the OK button for two seconds to reset displayed/selected features that can be reset.



1 — DID Controls

Compass Calibration

This compass is self-calibrating, which eliminates the need to set the compass manually. When the vehicle is new, the compass may appear erratic and the DID will display “CAL” until the compass is calibrated.

You may also calibrate the compass by completing one or more 360 degree turns (in an area free from large metal or metallic objects) until the “CAL” message displayed in the DID turns off. The compass will now function normally.

ECO

- The ECO message will appear in your DID display when the Fuel Saver Technology is active and you are driving in a fuel efficient manner.
- This feature allows you to monitor when you are driving in a fuel efficient manner, and it can be used to modify driving habits in order to increase fuel economy.

DID Main Menu Selectable Items

The DID can be used to view the following main menu items:

- Speedometer
- Vehicle Info
- Driver Assist
- Fuel Economy
- Trip Info
- Stop/Start Info — If Equipped
- Audio
- Messages
- Screen Setup

Refer to your Owner's Manual on the DVD for further information.

DID Screen Setup

The following settings allow you to change what information is displayed in the instrument cluster as well as the location that information is displayed:

- Compass
- Date
- Time
- Outside Temp
- Fuel Economy Info
- Speed
- Range to Empty

Trip A

- Push and release the UP or DOWN arrow button until the Trip A icon is highlighted in the DID (Toggle left or right to select Trip A or Trip B). Push and release the OK button to display the Trip A information.

Trip B

- Push and release the UP or DOWN arrow button until the Trip B icon is highlighted in the DID (Toggle left or right to select Trip A or Trip B). Push and release the OK button to display the Trip B information.

Fuel Economy

Push and release the **UP** or **DOWN** arrow button until the Fuel Economy icon is highlighted. Push the **RIGHT** arrow button and the next screen will display the following:

- Average Fuel Economy/Miles Per Gallon (MPG Bar graph)
- Range To Empty (RTE)
- Current Miles Per Gallon (MPG)

PROGRAMMABLE FEATURES

DID Programmable Features

The EVIC can be used to view the following main menu items:

NOTE:

Depending on the vehicles options, feature settings may vary.

- Speedometer
- MPH to km/h
- Vehicle Info
- Driver Assist
- Fuel Economy
- Trip
- Audio
- Stored Messages
- Screen Setup
- Speed Warning - If Equipped

NOTE:

Refer to your Owner's Manual on the DVD for further information.

Uconnect® Customer Programmable Features

The Uconnect® system allows you to access Customer Programmable feature settings such as Display, Voice, Clock, Safety & Driving Assistance, Lights, Doors & Locks, Auto-On Comfort & Remote Start, Engine Off Options, Compass Settings, Audio, Phone/Bluetooth®, SiriusXM Setup and System Information through buttons on the touchscreen.

- Push the MORE button (Uconnect® 5.0), or press the “Apps” button (Uconnect® 8.4) located near the bottom of the touchscreen, then press the “Settings” button on the touchscreen to access the Settings screen. When making a selection, scroll up or down until the preferred setting is highlighted, then press and release the preferred setting until a check-mark appears next to the setting, showing that setting has been selected. The following feature settings are available:
 - Display
 - Voice
 - Clock
 - Safety & Driving Assistance
 - Lights
 - Compass (Uconnect® 5.0)
 - Doors & Locks
 - Auto-On Comfort
 - Engine Off Options
 - Audio
 - Phone/Bluetooth®
 - SiriusXM Setup
 - Restore Settings
 - Clear Personal Data
 - System Information

NOTE:

Depending on the vehicles options, feature settings may vary.

DID Screen Setup

The following settings allow you to change what information is displayed in the instrument cluster as well as the location that information is displayed:

- Compass
- Date
- Time
- Outside Temp
- Fuel Economy Info
- Speed
- Range to Empty

Trip A

- Push and release the UP or DOWN arrow button until the Trip A icon is highlighted in the DID (Toggle left or right to select Trip A or Trip B). Push and release the OK button to display the Trip A information.

Trip B

- Push and release the UP or DOWN arrow button until the Trip B icon is highlighted in the DID (Toggle left or right to select Trip A or Trip B). Push and release the OK button to display the Trip B information.

Fuel Economy

Push and release the **UP** or **DOWN** arrow button until the Fuel Economy icon is highlighted. Push the **RIGHT** arrow button and the next screen will display the following:

- Average Fuel Economy/Miles Per Gallon (MPG Bar graph)
- Range To Empty (RTE)
- Current Miles Per Gallon (MPG)

UNIVERSAL GARAGE DOOR OPENER (HomeLink®)

- HomeLink® replaces up to three hand-held transmitters that operate devices such as garage door openers, motorized gates, lighting or home security systems. The HomeLink® unit is powered by your vehicles 12 Volt battery.
- The HomeLink® buttons that are located in the overhead console or sunvisor designate the three different HomeLink® channels.
- The HomeLink® indicator is located above the center button.

Before You Begin Programming HomeLink®

- Be sure that your vehicle is parked outside of the garage before you begin programming.
- For more efficient programming and accurate transmission of the radio-frequency signal it is recommended that a new battery be placed in the hand-held transmitter of the device that is being programmed to the HomeLink® system.
- Erase all channels before you begin programming. To erase the channels, place the ignition switch into the ON/RUN position, then press and hold the two outside HomeLink® buttons (I and III) for up to 20 seconds or until the red indicator flashes.



HomeLink® buttons

NOTE:

- Erasing all channels should only be performed when programming HomeLink® for the first time. Do not erase channels when programming additional buttons.
- If you have any problems, or require assistance, please call toll-free 1-800-355-3515 or, on the Internet at www.HomeLink.com for information or assistance.

Programming A Rolling Code

NOTE:

For programming Garage Door Openers that were manufactured after 1995. These Garage Door Openers can be identified by the "LEARN" or "TRAIN" button located where the hanging antenna is attached to the Garage Door Opener. It is NOT the button that is normally used to open and close the door. The name and color of the button may vary by manufacturer.

1. Place the ignition switch into the ON/RUN position.
2. Place the hand-held transmitter 1 to 3 inches (3 to 8 cm) away from the HomeLink® button you wish to program while keeping the HomeLink® indicator light in view.
3. Push and hold the HomeLink® button you want to program while you push and hold the hand-held transmitter button.
4. Continue to hold both buttons and observe the indicator light. The HomeLink® indicator will flash slowly and then rapidly after HomeLink® has received the frequency signal from the hand-held transmitter. Release both buttons after the indicator light changes from slow to rapid.

5. At the garage door opener motor (in the garage), locate the “LEARN” or “TRAINING” button. This can usually be found where the hanging antenna wire is attached to the garage door opener motor. Firmly push and release the “LEARN” or “TRAINING” button.

NOTE:

You have 30 seconds in which to initiate the next step after the LEARN button has been pushed.

6. Return to the vehicle and push the programmed HomeLink® button twice (holding the button for two seconds each time). If the device is plugged in and activates, programming is complete.

NOTE:

If the device does not activate, push the button a third time (for two seconds) to complete the training.

7. To program the remaining two HomeLink® buttons, repeat each step for each remaining button. DO NOT erase the channels.

Programming A Non-Rolling Code

NOTE:

For programming Garage Door Openers manufactured before 1995.

1. Turn the ignition switch to the ON/RUN position.
2. Place the hand-held transmitter 1 to 3 inches (3 to 8 cm) away from the HomeLink® button you wish to program while keeping the HomeLink® indicator light in view.
3. Push and hold the HomeLink® button you want to program while you push and hold the hand-held transmitter button.
4. Continue to hold both buttons and observe the indicator light. The HomeLink® indicator will flash slowly and then rapidly after HomeLink® has received the frequency signal from the hand-held transmitter. Release both buttons after the indicator light changes from slow to rapid.
5. Push and hold the programmed HomeLink® button and observe the indicator light. If the indicator light stays on constantly, programming is complete and the garage door (or device) should activate when the HomeLink® button is pushed.
6. To program the two remaining HomeLink® buttons, repeat each step for each remaining button. DO NOT erase the channels.

Using HomeLink®

To operate, push and release the programmed HomeLink® button. Activation will now occur for the programmed device (e.g., garage door opener, gate operator, security system, entry door lock, home/office lighting, etc.). The hand-held transmitter of the device may also be used at any time.

WARNING!

- Your motorized door or gate will open and close while you are programming the universal transceiver. Do not program the transceiver if people or pets are in the path of the door or gate.
- Do not run your vehicle in a closed garage or confined area while programming the transceiver. Exhaust gas from your vehicle contains Carbon Monoxide (CO) which is odorless and colorless. Carbon Monoxide is poisonous when inhaled and can cause you and others to be severely injured or killed.

POWER INVERTER

There is a 115 Volt, 150 Watt power inverter outlet located on the back of the center console. This outlet can power cellular phones, electronics and other low power devices requiring power up to 150 Watts.

NOTE:

- The power inverter is designed with built-in overload protection. If the power rating of 150 Watts is exceeded, the power inverter will automatically shut down. Once the electrical device has been removed from the outlet, the inverter should automatically reset.
- If the power rating exceeds approximately 170 Watts, the power inverter may have to be reset manually. To reset the inverter manually, unplug the device and plug it in again. To avoid overloading the circuit, check the power ratings on electrical devices prior to using the inverter.

**Power Inverter**

- 1 — USB Ports (Charging Only)
2 — Power Inverter Outlet

WARNING!

To Avoid Serious Injury or Death DO NOT:

- insert any objects into the receptacles
- touch with wet hands

Close the lid when not in use. If this outlet is mishandled, it may cause an electric shock and failure.

POWER OUTLET

The front power outlet is located in the front center storage bin of the instrument panel.

There is one power outlet located in the center console.

The rear power outlet is located in the right rear cargo area.

The power outlets are labeled with either a “key” or a “battery” symbol to indicate how the outlet is powered. Power outlets labeled with a “key” are powered when the ignition switch is in the ON/RUN or ACC position, while the outlets labeled with a “battery” are connected directly to the battery and powered at all times.

NOTE:

- Do not exceed the maximum power of 160 Watts (13 Amps) at 12 Volts. If the 160 Watt (13 Amp) power rating is exceeded, the fuse protecting the system will need to be replaced. See below image for fuse locations.
- Power outlets are designed for accessory plugs only. Do not insert any other object in the power outlet as this will damage the outlet and blow the fuse. Improper use of the power outlet can cause damage not covered by your new vehicle warranty.



Front Power Outlet



Center Console Outlet

- The rear cargo power outlet can be switched to “battery” powered all the time by switching the power outlet right rear quarter panel fuse in the fuse panel.

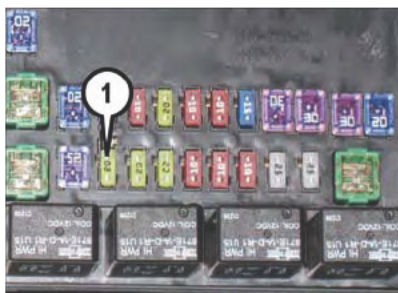

Rear Quarter Power Outlet Fuse

1 — F90-F91 Fuse 20A

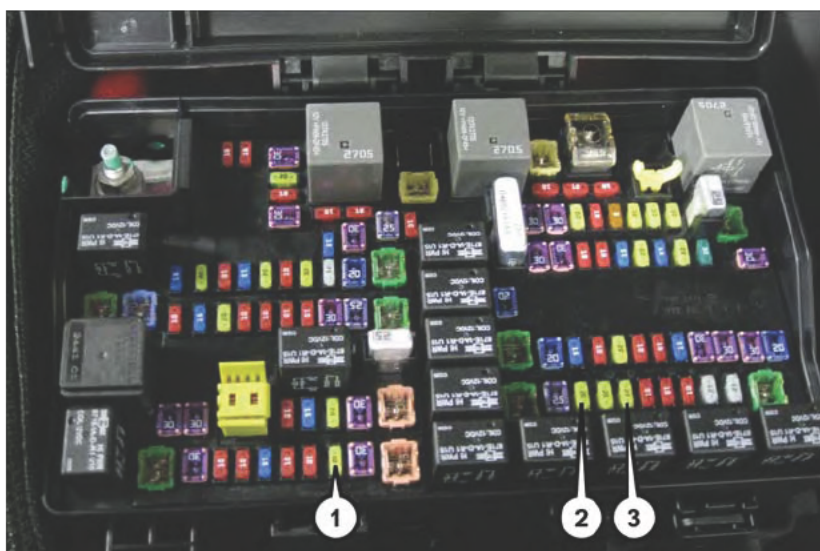

Power Outlet Fuse Locations

- 1 — F104 Fuse 20A Yellow Power Outlet Console Bin
- 2 — F90-F91 Fuse 20A Yellow Power Outlet Right Rear Quarter Panel
- 3 — F93 Fuse 20A Yellow Cigarette Lighter Instrument Panel

OFF-ROAD CAPABILITIES

ALL-WHEEL DRIVE OPERATION

Single-Speed Operating Instructions/Precautions

This system contains a single-speed (HI range only) transfer case, which provides convenient full-time all-wheel drive. No driver interaction is required. The Brake Traction Control (BTC) System, which combines standard ABS and Traction Control, provides resistance to any wheel that is slipping to allow additional torque transfer to wheels with traction.

NOTE:

This system is not appropriate for conditions where AWD LOW range is recommended. Refer to “Off-Road Driving Tips” in “Starting and Operating” on the DVD for further information.

Electronically Shifted Transfer Case (Three-Position Switch)

This electronic shift transfer case and is operated by the AWD Control Switch (Transfer Case Switch), which is located on the center console.

This electronically shifted transfer case provides three mode positions:

- All-wheel drive automatic range (AWD AUTO)
- All-wheel drive low range (LOW RANGE)
- Neutral (NEUTRAL)

When additional traction is required, the LOW RANGE position can be used to lock the front and rear driveshafts together forcing the front and rear wheels to rotate at the same speed. The LOW RANGE position are designed for loose, slippery road surfaces only. Driving in the LOW RANGE positions on dry hard surfaced roads may cause increased tire wear and damage to the drive-line components.

When operating your vehicle in LOW RANGE, the engine speed is approximately three times that of the AWD HI position at a given road speed. Take care not to overspeed the engine and do not exceed 25 mph (40 km/h).

NOTE:

The “SERV AWD Warning Light” monitors the electronic shift all-wheel drive system. If this light remains on after engine start up or illuminates during driving, it means that the all-wheel drive system is not functioning properly and that service is required.



AWD Control Switch

Shifting Procedures

AWD Auto To Low Range

NOTE:

When shifting into or out of LOW RANGE some gear noise may be heard. This noise is normal and is not detrimental to the vehicle or occupants.

- Shifting can be performed with the vehicle rolling 2 to 3 mph (3 to 5 km/h) or completely stopped. Use either of the following procedures:

Preferred Procedure

1. With the engine running, slow the vehicle to 2 to 3 mph (3 to 5 km/h).
2. Shift the transmission into NEUTRAL.
3. While still rolling, rotate the transfer case control switch to the desired position.
4. After the desired position indicator light is ON (not flashing), shift the transmission back into gear.

Alternate Procedure

1. Bring the vehicle to complete stop.
2. With the ignition switch in the ON position and the engine either OFF or running, shift the transmission into NEUTRAL.
3. Rotate the transfer case control switch to the desired position.
4. After the desired position indicator light is ON (not flashing), shift the transmission back into gear.

NOTE:

- If Steps 1 or 2 of either the Preferred or Alternate Procedure are not satisfied prior to attempting the shift or if they no longer are being met while the shift attempt is in process, the desired position indicator light will flash continuously while the original position indicator light is ON, until all requirements have been met.
- The ignition switch must be in the ON position for a shift to take place and for the position indicator lights to be operable. If the ignition switch is not in the ON position, then the shift will not take place and no position indicator lights will be on or flashing.

WARNING!

- Always engage the parking brake when powering down the vehicle if the "SERV AWD Warning Light" is illuminated. Not engaging the parking brake may allow the vehicle to roll which may cause personal injury.
- You or others could be injured or killed if you leave the vehicle unattended with the transfer case in the NEUTRAL position without first fully engaging the parking brake. The transfer case NEUTRAL position disengages both the front and rear driveshafts from the powertrain and will allow the vehicle to roll, even if the transmission is in PARK. The parking brake should always be applied when the driver is not in the vehicle.

ROOF LUGGAGE RACK

The crossbars on your vehicle are delivered stowed within the roof rack side rails. When installed, the roof rack can hold a maximum of 150 lbs (68 kg) of evenly distributed weight.

Installing The Crossbars

1. To install the crossbars, completely loosen the thumb screws at both ends and slide the crossbar out from its stowed position.
2. Bend the pivot points at each end of the crossbar and push the thumb screw down.

NOTE:

Position the crossbars across the roof making sure the letters on the crossbar align with the matching letters on the side rail.

3. Set the crossbars into position, slide them into the groove and tighten the thumb screws.
4. Refer to the Owner's Manual on the DVD for further details.

TRAILER TOWING WEIGHTS (MAXIMUM TRAILER WEIGHT RATINGS)

Engine	Model	GCWR (Gross Combined Wt. Rating)	Frontal Area	Max. GTW (Gross Trailer Wt.)	Max. Trailer Tongue Wt. (See Note)
3.6L	RWD Light Duty Cooling	8,900 lbs (4,037 kg)	40 sq ft (3.72 sq m)	3,500 lbs (1,588 kg)	350 lbs (159 kg)
3.6L	RWD	11,600 lbs (5,262 kg)	40 sq ft (3.72 sq m)	6,200 lbs (2,812 kg)	620 lbs (281 kg)
3.6L	AWD Light Duty Cooling	8,900 lbs (4,037 kg)	40 sq ft (3.72 sq m)	3,500 lbs (1,588 kg)	350 lbs (159 kg)
3.6L	AWD	11,600 lbs (5,262 kg)	40 sq ft (3.72 sq m)	6,200 lbs (2,812 kg)	620 lbs (281 kg)
5.7L	RWD	13,100 lbs (5,942 kg)	60 sq ft (5.57 sq m)	7,400 lbs (3,357 kg)	740 lbs (336 kg)
5.7L	AWD	13,100 lbs (5,942 kg)	60 sq ft (5.57 sq m)	7,200 lbs (3,266 kg)	720 lbs (327 kg)
Refer to local laws for maximum trailer towing speeds.					

NOTE:

- The trailer tongue weight must be considered as part of the combined weight of occupants and cargo, and should never exceed the weight referenced on the Tire and Loading Information placard. Refer to "Tire Safety Information" in "Starting and Operating" for further information. The addition of passengers and cargo may require reducing trailer tongue load and Gross Trailer Weight (GTW). Redistributing cargo (to the trailer) may be necessary to avoid exceeding Rear Gross Axle Weight Rating (GAWR) of 3,900 lbs (1 769 kg).
- Vehicles not factory equipped with trailer tow package are limited to 3,500 lbs (350 lbs tongue weight).

Trailer Hitch Receiver Cover Removal — If Equipped

Your vehicle may be equipped with a trailer hitch receiver cover, this must be removed to access the trailer hitch receiver (if equipped). This cover is located at the bottom center of the rear fascia.

1. Turn the two locking retainers located at the bottom of the hitch receiver cover a 1/4 turn counterclockwise and pull bottom of the hitch receiver cover outward (towards you).

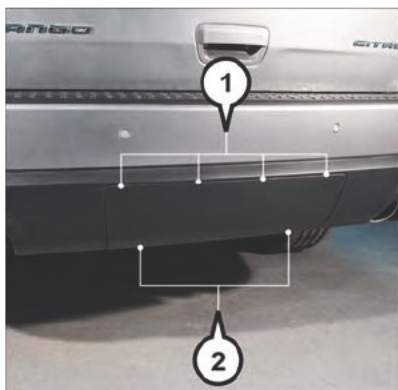

Hitch Receiver Cover

- 1 — Cover Tab Locations
2 — Locking Retainers

2. Pull the bottom of the cover outward (towards you) then downwards to disengage the tabs located at the top of the hitch receiver cover to remove.



Hitch Receiver Cover

To reinstall the cover after towing repeat the procedure in reverse order.

NOTE:

Be sure to engage all tabs of the hitch receiver cover in the bumper fascia prior to installation.



Hitch Receiver Cover

- 1 — Cover Tab Locations
- 2 — Locking Retainers

RECREATIONAL TOWING (BEHIND MOTORHOME, ETC.)

Towing This Vehicle Behind Another Vehicle

Towing Condition	Wheels OFF the Ground	Rear-Wheel Drive Models	All-Wheel Drive Models With Single-Speed Transfer Case	All-Wheel Drive Models With Two-Speed Transfer Case
Flat Tow	NONE	NOT ALLOWED	NOT ALLOWED	<ul style="list-style-type: none"> • See Instructions • Transmission in PARK • Transfer case in NEUTRAL (N) • Tow in forward direction
Dolly Tow	Front	NOT ALLOWED	NOT ALLOWED	NOT ALLOWED
	Rear	OK	NOT ALLOWED	NOT ALLOWED
On Trailer	ALL	OK	OK	OK

NOTE:

When recreational towing your vehicle, always follow applicable state and provincial laws. Contact state and provincial Highway Safety offices for additional details.

Recreational Towing — Rear-Wheel Drive Models

DO NOT flat tow this vehicle. Damage to the drivetrain will result.

Recreational towing (for two-wheel drive models) is allowed **ONLY** if the rear wheels are **OFF** the ground. This may be accomplished using a tow dolly or vehicle trailer. If using a tow dolly, follow this procedure:

1. Properly secure the dolly to the tow vehicle, following the dolly manufacturer's instructions.
2. Drive the rear wheels onto the tow dolly.
3. Firmly apply the parking brake. Shift the transmission into PARK.
4. Turn the ignition switch to the OFF position.
5. Properly secure the rear wheels to the dolly, following the dolly manufacturer's instructions.
6. Install a suitable clamping device, designed for towing, to secure the front wheels in the straight position.

CAUTION!

Towing with the rear wheels on the ground will cause severe transmission damage. Damage from improper towing is not covered under the New Vehicle Limited Warranty.

Recreational Towing — All-Wheel Drive Models (Single-Speed Transfer Case)

Recreational towing is not allowed. These models do not have a NEUTRAL (N) position in the transfer case.

NOTE:

This vehicle may be towed on a flatbed or vehicle trailer provided all four wheels are **OFF** the ground.

CAUTION!

Towing this vehicle in violation of the above requirements can cause severe transmission and/or transfer case damage. Damage from improper towing is not covered under the New Vehicle Limited Warranty.

Recreational Towing — All-Wheel Drive Models (Two-Speed Transfer Case)

The transfer case must be shifted into NEUTRAL (N) and the transmission must be in PARK for recreational towing. The NEUTRAL (N) selection button is adjacent to the transfer case selector switch. Shifts into and out of transfer case NEUTRAL (N) can take place with the selector switch in any mode position.

CAUTION!

- DO NOT dolly tow any AWD vehicle. Towing with only one set of wheels on the ground (front or rear) will cause severe transmission and/or transfer case damage. Tow with all four wheels either ON the ground, or OFF the ground (using a vehicle trailer).
- Tow only in the forward direction. Towing this vehicle backwards can cause severe damage to the transfer case.
- The transmission must be in PARK for recreational towing.
- Before recreational towing, perform the procedure outlined under "Shifting Into NEUTRAL(N)" to be certain that the transfer case is fully in NEUTRAL (N). Otherwise, internal damage will result.
- Towing this vehicle in violation of the above requirements can cause severe transmission and/or transfer case damage. Damage from improper towing is not covered under the New Vehicle Limited Warranty.
- Do not use a bumper-mounted clamp-on tow bar on your vehicle. The bumper face bar will be damaged.

Shifting Into NEUTRAL (N)**WARNING!**

You or others could be injured or killed if you leave the vehicle unattended with the transfer case in the NEUTRAL (N) position without first fully engaging the parking brake. The transfer case NEUTRAL (N) position disengages both the front and rear driveshafts from the powertrain and will allow the vehicle to roll, even if the transmission is in PARK. The parking brake should always be applied when the driver is not in the vehicle.

Use the following procedure to prepare your vehicle for recreational towing.

CAUTION!

It is necessary to follow these steps to be certain that the transfer case is fully in NEUTRAL (N) before recreational towing to prevent damage to internal parts.

1. Bring the vehicle to a complete stop, with the engine running.
2. Press and hold the brake pedal.
3. Shift the transmission into NEUTRAL.
4. Using a ballpoint pen or similar object, press and hold the recessed transfer case NEUTRAL (N) button (located by the selector switch) for four seconds. The light behind the N symbol will blink, indicating shift in progress. The light will stop blinking

(stay on solid) when the shift to NEUTRAL (N) is complete. A "FOUR WHEEL DRIVE SYSTEM IN NEUTRAL" message will appear in the Driver Information Display (DID). Refer to "Driver Information Display (DID)" in "Understanding Your Instrument Panel" for further information.

5. After the shift is completed and the NEUTRAL (N) light stays on, release the NEUTRAL (N) button.
6. Shift the transmission into REVERSE.
7. Release the brake pedal for five seconds and ensure that there is no vehicle movement.
8. Shift the transmission back into NEUTRAL.
9. Firmly apply the parking brake.
10. With the transmission and transfer case in NEUTRAL, press and hold the ENGINE START/STOP button until the engine turns off. Turning the engine off will automatically place the transmission in PARK.
11. Press the ENGINE STOP/START button again (without pressing the brake pedal), if needed, to turn the ignition switch to the OFF position.

CAUTION!

Damage to the transmission may occur if the transmission is shifted into PARK with the transfer case in NEUTRAL (N) and the engine running. With the transfer case in NEUTRAL (N) ensure that the engine is OFF before shifting the transmission into PARK.

12. Attach the vehicle to the tow vehicle using a suitable tow bar.
13. Release the parking brake.

NOTE:

- Steps 1 through 3 are requirements that must be met before pressing the NEUTRAL (N) button, and must continue to be met until the shift has been completed. If any of these requirements are not met before pressing the NEUTRAL (N) button or are no longer met during the shift, the NEUTRAL (N) indicator light will flash continuously until all requirements are met or until the NEUTRAL (N) button is released.
- The ignition switch must be in the ON/RUN position for a shift to take place and for the position indicator lights to be operable. If the ignition switch is not in the ON/RUN position, the shift will not take place and no position indicator lights will be on or flashing.
- A flashing NEUTRAL (N) position indicator light indicates that shift requirements have not been met.

Shifting Out Of NEUTRAL (N)

Use the following procedure to prepare your vehicle for normal usage.

1. Bring the vehicle to a complete stop, leaving it connected to the tow vehicle.
2. Firmly apply the parking brake.
3. Start the engine.
4. Press and hold the brake pedal.
5. Shift the transmission into NEUTRAL.
6. Using a ballpoint pen or similar object, press and hold the recessed transfer case NEUTRAL (N) button (located by the selector switch) for one second.
7. When the NEUTRAL (N) indicator light turns off, release the NEUTRAL (N) button.
8. After the NEUTRAL (N) button has been released, the transfer case will shift to the position indicated by the selector switch.
9. Shift the transmission into PARK and turn the engine OFF.
10. Release the brake pedal.
11. Disconnect vehicle from the tow vehicle.
12. Start the engine.
13. Press and hold the brake pedal.
14. Release the parking brake.
15. Shift the transmission into DRIVE, release the brake pedal, and check that the vehicle operates normally.

NOTE:

- Steps 1 through 5 are requirements that must be met before pressing the NEUTRAL (N) button, and must continue to be met until the shift has been completed. If any of these requirements are not met before pressing the NEUTRAL (N) button or are no longer met during the shift, the NEUTRAL (N) indicator light will flash continuously until all requirements are met or until the NEUTRAL (N) button is released.
- The ignition switch must be in the ON/RUN position for a shift to take place and for the position indicator lights to be operable. If the ignition switch is not in the ON/RUN position, the shift will not take place and no position indicator lights will be on or flashing.
- A flashing NEUTRAL (N) position indicator light indicates that shift requirements have not been met.

WHAT TO DO IN EMERGENCIES

ROADSIDE ASSISTANCE

Dial toll-free 1-800-521-2779 for U.S. Residents or 1-800-363-4869 for Canadian Residents.

- Provide your name, vehicle identification number, license plate number, and your location, including the telephone number from which you are calling.
- Briefly describe the nature of the problem and answer a few simple questions.
- You will be given the name of the service provider and an estimated time of arrival. If you feel you are in an “unsafe situation”, please let us know. With your consent, we will contact local police or safety authorities.

INSTRUMENT CLUSTER WARNING LIGHTS

- Tire Pressure Monitoring System (TPMS) Light

Each tire, including the spare (if provided), should be checked monthly, when cold and inflated to the inflation pressure recommended by the vehicle manufacturer on the vehicle placard or tire inflation pressure label. (If your vehicle has tires of a different size than the size indicated on the vehicle placard or tire inflation pressure label, you should determine the proper tire inflation pressure for those tires.)

As an added safety feature, your vehicle has been equipped with a Tire Pressure Monitoring System (TPMS) which display in the Electronic Vehicle Information Center (EVIC) or Driver Information Display (DID) when one or more of your tires is significantly under-inflated. Accordingly, when the low tire pressure EVIC or DID display illuminates, you should stop and check your tires as soon as possible, and inflate them to the proper pressure. Driving on a significantly under-inflated tire causes the tire to overheat and can lead to tire failure. Under-inflation also reduces fuel efficiency and tire tread life, and may affect the vehicle's handling and stopping ability.

IF THE LIGHT STARTS FLASHING INDICATING A LOW TIRE PRESSURE, ADJUST THE AIR PRESSURE IN THE LOW TIRE TO THE AIR PRESSURE SHOWN ON THE VEHICLE PLACARD OR TIRE INFLATION PRESSURE LABEL LOCATED ON THE DRIVER'S DOOR.

NOTE:

After inflation, the vehicle may need to be driven for 20 minutes before the flashing light will turn off.

WHAT TO DO IN EMERGENCIES

Please note that the TPMS is not a substitute for proper tire maintenance, and it is the driver's responsibility to maintain correct tire pressure, even if under-inflation has not reached the level to trigger illumination of the TPMS low EVIC or DID display.

Your vehicle has also been equipped with a TPMS malfunction indicator to indicate when the system is not operating properly. The TPMS malfunction indicator is combined with the low tire pressure telltale. When the system detects a malfunction, the telltale will flash for approximately one minute and then remain continuously illuminated. This sequence will continue each time the vehicle is restarted as long as the malfunction exists.

When the malfunction indicator is illuminated, the system may not be able to detect or signal low tire pressure as intended. TPMS malfunctions may occur for a variety of reasons, including the installation of replacement or alternate tires or wheels on the vehicle that prevent the TPMS from functioning properly. Always check the TPMS malfunction telltale after replacing one or more tires or wheels on your vehicle, to ensure that the replacement or alternate tires and wheels allow the TPMS to continue to function properly.

NOTE:

Tire pressures change by approximately 1 psi (7 kPa) per 12° F (7° C) of air temperature change. Keep this in mind when checking tire pressure inside a garage, especially in the Winter. Example: If garage temperature is 68°F (20°C) and the outside temperature is 32°F (0°C), then the cold tire inflation pressure should be increased by 3 psi (21 kPa), which equals 1 psi (7 kPa) for every 12°F (7°C) for this outside temperature condition.

CAUTION!

The TPMS has been optimized for the original equipment tires and wheels. TPMS pressures and warning have been established for the tire size equipped on your vehicle. Undesirable system operation or sensor damage may result when using replacement equipment that is not of the same size, type, and/or style. Aftermarket wheels can cause sensor damage. Do not use tire sealant from a can, or balance beads if your vehicle is equipped with a TPMS, as damage to the sensors may result.

BRAKE - Brake Warning Light

This light monitors various brake functions, including brake fluid level and parking brake application. If the brake light turns on, it may indicate that the parking brake is applied, that the brake fluid level is low, or that there is a problem with the anti-lock brake system reservoir.

If the light remains on when the parking brake has been disengaged, and the fluid level is at the full mark on the master cylinder reservoir, it indicates a possible brake hydraulic system malfunction or that a problem with the Brake Booster has been detected by the Anti-Lock Brake System (ABS)/Electronic Stability Control (ESC) system. In this case, the light will remain on until the condition has been corrected. If the problem is related to the brake booster, the ABS pump will run when applying the brake, and a brake pedal pulsation may be felt during each stop.

WHAT TO DO IN EMERGENCIES

The dual brake system provides a reserve braking capacity in the event of a failure to a portion of the hydraulic system. A leak in either half of the dual brake system is indicated by the Brake Warning Light, which will turn on when the brake fluid level in the master cylinder has dropped below a specified level. The light will remain on until the cause is corrected.

Vehicles equipped with the Anti-Lock Brake System (ABS) are also equipped with Electronic Brake Force Distribution (EBD). In the event of an EBD failure, the Brake Warning Light will turn on along with the ABS Light. Immediate repair to the ABS system is required.

Operation of the Brake Warning Light can be checked by turning the ignition switch from the OFF position to the ON/RUN position. The light should illuminate for approximately two seconds. The light should then turn off unless the parking brake is applied or a brake fault is detected. If the light does not illuminate, have the light inspected by an authorized dealer.

The light also will turn on when the parking brake is applied with the ignition switch in the ON/RUN position.

NOTE:

This light shows only that the parking brake is applied. It does not show the degree of brake application.

WARNING!

Driving a vehicle with the red brake light on is dangerous. Part of the brake system may have failed. It will take longer to stop the vehicle. You could have a collision. Have the vehicle checked immediately.



- Malfunction Indicator Light (MIL)

The Malfunction Indicator Light (MIL) is part of an onboard diagnostic system called OBD II that monitors engine and automatic transmission control systems. The light will illuminate when the key is in the ON/RUN position before engine start. If the bulb does not come on when turning the key from OFF to ON/RUN, have the condition checked promptly.

Certain conditions, poor fuel quality, etc., may illuminate the light after engine start. The vehicle should be serviced if the light stays on through several of your typical driving cycles. In most situations, the vehicle will drive normally and will not require towing.

CAUTION!

Prolonged driving with the Malfunction Indicator Light (MIL) on could cause damage to the engine control system. It also could affect fuel economy and driveability. If the MIL is flashing, severe catalytic converter damage and power loss will soon occur. Immediate service is required.

WHAT TO DO IN EMERGENCIES

WARNING!

A malfunctioning catalytic converter, as referenced above, can reach higher temperatures than in normal operating conditions. This can cause a fire if you drive slowly or park over flammable substances such as dry plants, wood, cardboard, etc. This could result in death or serious injury to the driver, occupants or others.

- Electronic Stability Control (ESC) Activation/Malfunction Indicator Light

The “ESC Activation/Malfunction Indicator Light” in the instrument cluster will come on when the ignition switch is turned to the ON/RUN position. It should go out with the engine running. If the “ESC Activation/Malfunction Indicator Light” comes on continuously with the engine running, a malfunction has been detected in the ESC system. If this light remains on after several ignition cycles, and the vehicle has been driven several miles (kilometers) at speeds greater than 30 mph (48 km/h), see your authorized dealer as soon as possible to have the problem diagnosed and corrected.

NOTE:

- The “ESC Off Indicator Light” and the “ESC Activation/Malfunction Indicator Light” come on momentarily each time the ignition switch is turned to ON/RUN.
- Each time the ignition is turned to ON/RUN, the ESC system will be ON, even if it was turned off previously.
- The ESC system will make buzzing or clicking sounds when it is active. This is normal; the sounds will stop when ESC becomes inactive following the maneuver that caused the ESC activation.
- To improve the vehicle's traction when starting off in deep snow, sand or gravel, it may be desirable to switch the ESC system to Partial Off mode by momentarily pressing the ESC Off  switch located below the climate controls, on the switch panel.

- Charging System Light

This light shows the status of the electrical charging system. If the charging system light remains on, it means that the vehicle is experiencing a problem with the charging system.

We recommend you do not continue driving if the charging system light is on. Have the vehicle serviced immediately.

- Oil Pressure Warning Light

This light indicates low engine oil pressure. If the light turns on while driving, stop the vehicle and shut off the engine as soon as possible. A chime will sound for four minutes when this light turns on.

We recommend you do not operate the vehicle or engine damage will occur. Have the vehicle serviced immediately.

WHAT TO DO IN EMERGENCIES

- Anti-Lock Brake (ABS) Light

This light monitors the Anti-Lock Brake System (ABS). The light will turn on when the ignition switch is turned to the ON/RUN position and may stay on for as long as four seconds.

If the ABS light remains on or turns on while driving, it indicates that the Anti-Lock portion of the brake system is not functioning and that service is required. However, the conventional brake system will continue to operate normally if the BRAKE warning light is not on.

If the ABS light is on, the brake system should be serviced as soon as possible to restore the benefits of Anti-Lock brakes. If the ABS light does not turn on when the ignition switch is turned to the ON/RUN position, have the light inspected by an authorized dealer.

- Electronic Throttle Control (ETC) Light

This light informs you of a problem with the Electronic Throttle Control (ETC) system.

If a problem is detected, the light will come on while the engine is running. Cycle the ignition key when the vehicle has completely stopped and the shift lever/gear selector is placed in the PARK position; the light should turn off.

If the light remains lit with the engine running, your vehicle will usually be drivable. However, see an authorized service center immediately. If the light is flashing when the engine is running, immediate service is required and you may experience reduced performance, an elevated/rough idle or engine stall and your vehicle may require towing.

- Air Bag Warning Light

This light will turn on for four to eight seconds as a bulb check when the ignition switch is first turned to the ON/RUN position. If the light is either not on during starting, stays on, or turns on while driving, have the system inspected at an authorized dealer as soon as possible. Refer to "Occupant Restraints" in "Things To Know Before Starting Your Vehicle" in your Owner's Manual on the DVD for further information.

NOTE:





The Air Bag System is designed to be maintenance free.

Oil Life Reset





Your vehicle is equipped with an engine oil change indicator system. The "Oil Change Due" message will flash in the DID display for approximately 10 seconds after a single chime has sounded, to indicate the next scheduled oil change interval. The engine oil change indicator system is duty cycle based, which means the engine oil change interval may fluctuate, dependent upon your personal driving style.

WHAT TO DO IN EMERGENCIES

Vehicles Equipped With Passive Entry

- Without pushing the brake pedal, push the ENGINE START/STOP button and cycle the ignition to the ON/RUN position (Do not start the engine).
- Push and release the **DOWN**  arrow button to scroll downward through the main menu to "Vehicle Info."
- Push and release the **RIGHT**  arrow button to access the "Oil Life" screen.
- Push and hold the **RIGHT**  arrow button for one second to access the "Oil Life Reset" screen.
- Push and hold the **DOWN**  arrow button until the screen shows 100% oil life.
- Push and release the **Up** arrow button to exit the DID screen.

Vehicles Not Equipped With Passive Entry

- Without pushing the brake pedal, cycle the ignition to the ON/RUN position (Do not start the engine).
- Push and release the **DOWN**  arrow button to scroll downward through the main menu to "Vehicle Info."
- Push and release the **RIGHT**  arrow button to access the "Oil Life" screen.
- Push and hold the **RIGHT**  arrow button for one second to access the "Oil Life Reset" screen.
- Push and hold the **DOWN**  arrow button until the screen shows 100% oil life.
- Push and release the **Up** arrow button to exit the DID screen.

NOTE:

If the indicator message illuminates when you start the vehicle, the oil change indicator system did not reset. If necessary, repeat this procedure.

INSTRUMENT CLUSTER INDICATOR LIGHTS

- Low Fuel Warning Light

This warning light indicates when the fuel level reaches approximately 2.0 gal (7.8 L). This light will turn on and a single chime will sound.

- Turn Signal Indicator

The arrows will flash with the exterior turn signals when the turn signal lever is operated. A tone will chime, and a DID message will appear if either turn signal is left on for more than 1 mile (1.6 km).

NOTE:

If either indicator flashes at a rapid rate, check for a defective outside light bulb.

WHAT TO DO IN EMERGENCIES

- High Beam Indicator

Indicates that headlights are on high beam.

- Front Fog Light Indicator

This indicator will illuminate when the front fog lights are on.

- Park/Headlight ON Indicator

This indicator will illuminate when the park lights or headlights are turned on.

- Vehicle Security Light

This light will flash rapidly for approximately 15 seconds when the vehicle security alarm is arming. The light will flash at a slower speed continuously after the alarm is set. The security light will also come on for about three seconds when the ignition is first turned on.

- Electronic Speed Control ON Indicator

This indicator will illuminate when the electronic speed control has been activated to the “ON” position.

- Electronic Speed Control SET Indicator

This indicator will illuminate when the cruising speed has been set.

- Hill Descent Control Indicator — If Equipped

This indicator will illuminate when Hill Descent Control (HDC) has been selected using the Hill Descent Control Switch.

- Door Ajar Indicator

This indicator will illuminate when a door(s) is left ajar and not fully closed.

- Electronic Stability Control (ESC) OFF Indicator Light

This light indicates the Electronic Stability Control (ESC) is off.

- Windshield Washer Fluid Low Indicator

This indicator will illuminate when the windshield washer fluid is low.

- Liftgate Ajar Indicator — If Equipped

This indicator will illuminate when the liftgate is left ajar and not fully closed.

Engine Oil Life Reset

Oil Change Required

Your vehicle is equipped with an engine oil change indicator system. The “Oil Change Required” message will display in the DID for five seconds after a single chime has sounded, to indicate the next scheduled oil change interval. The engine oil change indicator system is duty cycle based, which means the engine oil change interval may fluctuate, dependent upon your personal driving style.

WHAT TO DO IN EMERGENCIES

Unless reset, this message will continue to display each time you turn the ignition switch to the ON/RUN position or cycle the ignition to the ON/RUN position if equipped with Keyless Enter-N-Go™. To turn off the message temporarily, press and release the OK button. To reset the oil change indicator system (after performing the scheduled maintenance) refer to the following procedure.

Vehicles Equipped With Keyless Enter-N-Go™

1. Without pressing the brake pedal, press the ENGINE START/STOP button and place the ignition to the ON/RUN position (do not start the engine.)
2. Fully depress the accelerator pedal, slowly, three times within 10 seconds.
3. Without pressing the brake pedal, press the ENGINE START/STOP button once to return the ignition to the OFF/LOCK position.

NOTE:

If the indicator message illuminates when you start the vehicle, the oil change indicator system did not reset. If necessary, repeat this procedure.

IF YOUR ENGINE OVERHEATS

In any of the following situations, you can reduce the potential for overheating by taking the appropriate action:

- On the highways — slow down.
- In city traffic — while stopped, shift the transmission to NEUTRAL, but do not increase engine idle speed.

NOTE:

There are steps that you can take to slow down an impending overheat condition:

- If your air conditioner (A/C) is on, turn it off. The A/C system adds heat to the engine cooling system and turning the A/C off can help remove this heat.
- You can also turn the temperature control to maximum heat, the mode control to floor and the blower control to high. This allows the heater core to act as a supplement to the radiator and aids in removing heat from the engine cooling system.

CAUTION!

Driving with a hot cooling system could damage your vehicle. If the temperature gauge reads HOT (H), pull over and stop the vehicle. Idle the vehicle with the air conditioner turned off until the pointer drops back into the normal range. If the pointer remains on HOT (H), and you hear continuous chimes, turn the engine off immediately, and call for service.

WHAT TO DO IN EMERGENCIES

WARNING!

You or others can be badly burned by hot engine coolant (antifreeze) or steam from your radiator. If you see or hear steam coming from under the hood, do not open the hood until the radiator has had time to cool. Never try to open a cooling system pressure cap when the radiator or coolant bottle is hot.

JACKING AND TIRE CHANGING

Jack Location

The scissor-type jack and tire changing tools are located in rear cargo area, below the load floor.

- Rotate the plastic thumb screw on the end of the jack to remove the jack from the bracket.



Jack Location



Jack Removal

WHAT TO DO IN EMERGENCIES

Spare Tire Stowage

The spare tire is stowed under the rear of the vehicle by means of a cable winch mechanism. To remove or stow the spare, use the jack handle/lug wrench connected to the square socket extension to rotate the “spare tire drive” nut. The nut is located under a plastic cover at the center-rear of the cargo floor area, just inside the liftgate opening.



Spare Tire Location

Spare Tire Removal

1. Remove the jack tools from the bag.
2. Raise the protective rubber mat covering the storage compartment floor and remove the plug to access the winch drive.
3. Fit the jack handle extension over the drive nut. Use the lug wrench handle and extension to completely lower the spare tire. Keep turning the handle until the winch STOPS.

NOTE:

Do not use power tools to operate the winch.



Winch Drive Nut Location

WHAT TO DO IN EMERGENCIES

4. Slide the tire out from under the vehicle and rotate it vertically behind the rear bumper.



Spare Tire Removal

5. Spread the retaining tabs on the plastic plate and pull the metal stamping toward you to release it from the plastic plate.



Spare Tire Retainer

WHAT TO DO IN EMERGENCIES

- Slide the metal stamping up the steel extension tube and winch cable. Rotate the metal stamping and push it through the hole in the plastic plate and wheel.



Retainer Removal

- Pinch the three short and two long tubes to remove the protective plate from the steel spare wheel.



Protective Plate Removal

Preparations For Jacking

- Park the vehicle on a firm level surface, away from traffic for your safety.
- Turn the engine off, place the transmission in PARK, fully depress the pedal to the floor to set the parking brake, and activate the Hazard Warning flashers.

WHAT TO DO IN EMERGENCIES

3. Block both the front and rear of the wheel diagonally opposite of the jacking position.

NOTE:

Passengers should not remain in the vehicle when the vehicle is being jacked.



Wheel Blocked

Jacking Instructions

1. Loosen the lug nuts on the road wheel one turn while still on the ground, but do not remove.



Jack Warning Label

WHAT TO DO IN EMERGENCIES

2. Determine the jacking location on the side of the vehicle. Attach the jack tool with the hook, the extension and the lug wrench to the jack as shown.



Assembled Jack



Jacking Locations

WHAT TO DO IN EMERGENCIES

3. For the front axle, place the jack on the body flange just behind the front tire as indicated by the triangular lift point symbol on the sill molding. **Do not raise the vehicle until you are sure the jack is fully engaged.**



Front Jacking Location

4. For a rear tire, place the jack in the slot on the rear tie-down bracket, just forward of the rear tire (as indicated by the triangular lift point symbol on the sill molding). **Do not raise the vehicle until you are sure the jack is fully engaged.**
5. Raise the vehicle by turning the jack screw clockwise. Raise the vehicle just enough to remove the flat tire.
6. Remove the lug nuts and wheel.

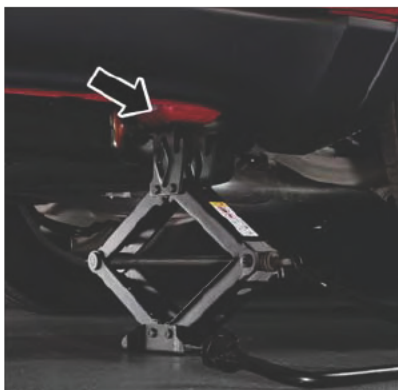

Rear Jacking Location

WHAT TO DO IN EMERGENCIES

7. Install the temporary spare wheel/tire and lightly tighten the lug nuts prior to lowering to prevent the vehicle from moving on the jack.
8. Lower the vehicle by turning the jack screw counterclockwise, and remove the jack.
9. Finish tightening the lug nuts. Push down on the wrench while at the end of the handle for increased leverage. Tighten the lug nuts in a star pattern until each nut has been tightened twice. The correct wheel nut tightness is 130 ft lbs (176 N·m). If in doubt about the correct tightness, have them checked with a torque wrench by your authorized dealer or at a service station.
10. Remove the Dodge center cap using a jack tool from inside the aluminum road wheel and snap on the protective plastic plate.

NOTE:

The plastic plate will prevent the road wheel from being scratched when sliding it under the vehicle.

11. Stand the wheel up against the bumper with the plastic plate facing you.
12. Slide the cable end, spring and metal tube through the wheel and plastic plate. Rotate the stamping on the cable and push it through the wheel and plastic plate. Snap the stamping into place.



Spare Tire Mounting



Protective Plate

WHAT TO DO IN EMERGENCIES

- Slide the road wheel on the ground using the protective plate until it is directly under the winch and between the rear bumper and exhaust system heat shields. Raise the tire by turning the lug wrench on the winch extension clockwise until it clicks/skips three times to make sure the cable is tight.

NOTE:

Double check to ensure the tire is snug against the underbody of the vehicle. Damage to the winch cable may result if the vehicle is driven with the tire loose.

- Lower the jack to the fully closed position. Return the tools to the proper positions in the tool bag. Fold the flap on the tool bag under the tools and roll the tools in the bag underneath the others. Use the Velcro® straps to secure the tool bag to the jack with the lug wrench on the forward side of the jack. Expand the jack on the bracket by turning the thumb screw clockwise until it is tight to prevent rattles.

- Reinstall the plastic plug into the floor of the cargo area. Roll up and store the Jack, Tool Kit and Tire Changing Instructions. Reinstall the cover for the jack in the rear storage bin.

NOTE:

The plastic thumb screw being on the right and the position of the lug wrench before the Velcro® straps go around the fully closed jack.

- Remove the blocks/rocks from the opposite tire.
- Have the aluminum road wheel and tire repaired as soon as possible and properly secure the spare tire, jack and tool kit.



Flat Tire Storage



Jack Assembly

WHAT TO DO IN EMERGENCIES

Road Tire Installation

1. Mount the road tire on the axle.
2. Install the remaining lug nuts with the cone shaped end of the nut toward the wheel. Lightly tighten the lug nuts.
3. Lower the vehicle to the ground by turning the jack handle counterclockwise.
4. Finish tightening the lug nuts. Push down on the wrench while at the end of the handle for increased leverage. Tighten the lug nuts in a star pattern until each nut has been tightened twice. The correct tightness of each lug nut is 130 ft/lbs (176 N·m). If in doubt about the correct tightness, have them checked with a torque wrench by your authorized dealer or service station.
5. After 25 miles (40 km) check the lug nut torque with a torque wrench to ensure that all lug nuts are properly seated against the wheel.

CAUTION!

- Do not use power tools to winch the tire up or down. Impact type tools can damage the winch mechanism.
- Do not attempt to raise the vehicle by jacking on locations other than those indicated in the Jacking Instructions for this vehicle.
- Be sure to mount the spare tire with the valve stem facing outward. The vehicle could be damaged if the spare tire is mounted incorrectly.

WHAT TO DO IN EMERGENCIES

WARNING!

- Do not attempt to change a tire on the side of the vehicle close to moving traffic. Pull far enough off the road to avoid the danger of being hit when operating the jack or changing the wheel.
- Being under a jacked-up vehicle is dangerous. The vehicle could slip off the jack and fall on you. You could be crushed. Never put any part of your body under a vehicle that is on a jack. If you need to get under a raised vehicle, take it to a service center where it can be raised on a lift.
- The jack is designed to be used as a tool for changing tires only. The jack should not be used to lift the vehicle for service purposes. The vehicle should be jacked on a firm level surface only. Avoid ice or slippery areas.
- Always park on a firm, level surface as far from the edge of the roadway as possible before raising the vehicle.
- Turn on the Hazard Warning flasher.
- Block the wheel diagonally opposite the wheel to be raised.
- Set the parking brake firmly and set the automatic transmission in PARK.
- Never start or run the engine with the vehicle on a jack.
- Do not let anyone sit in the vehicle when it is on a jack.
- Do not get under the vehicle when it is on a jack.
- Only use the jack in the positions indicated and for lifting this vehicle during a tire change.
- If working on or near a roadway, be extremely careful of motor traffic.
- To assure that spare tires, flat or inflated, are securely stowed, spares must be stowed with the valve stem facing the ground. Carefully follow these tire changing warnings to help prevent personal injury or damage to your vehicle:
 - Raising the vehicle higher than necessary can make the vehicle less stable. It could slip off the jack and hurt someone near it. Raise the vehicle only enough to remove the tire.
 - To avoid the risk of forcing the vehicle off the jack, do not fully tighten the wheel nuts until the vehicle has been lowered. Failure to follow this warning may result in personal injury.
 - Do not use power tools to winch the tire up or down. Impact-type tools may damage the winch mechanism.
 - A loose tire or jack, thrown forward in a collision or hard stop could endanger the occupants of the vehicle. Always stow the jack parts and the spare tire in the places provided.
 - To avoid the risk of forcing the vehicle off the jack, do not tighten the lug nuts fully until the vehicle is lowered to the ground.

WHAT TO DO IN EMERGENCIES

BATTERY LOCATION

The battery in your vehicle is located under the passenger's front seat. Remote battery posts are located on the right side of the engine compartment for jump-starting.

JUMP-STARTING

If your vehicle has a discharged battery it can be jump-started using a set of jumper cables and a battery in another vehicle or by using a portable battery booster pack.

Jump-starting can be dangerous if done improperly so please follow the procedures in this section carefully.

NOTE:

When using a portable battery booster pack follow the manufacturer's operating instructions and precautions.

Preparations For Jump-Start

The battery in your vehicle is located under the passenger's front seat. There are remote locations under the hood to assist in jump starting.

- Set the parking brake, shift the automatic transmission into PARK and turn the ignition to OFF.
- Turn off the heater, radio, and all unnecessary electrical accessories.
- Remove the protective cover over the remote positive (+) battery post. Pull upward on the cover to remove it.
- Remove the protective plug covering the remote negative (-) post.
- If using another vehicle to jump-start the battery, park the vehicle within the jumper cables reach, set the parking brake and make sure the ignition is OFF.

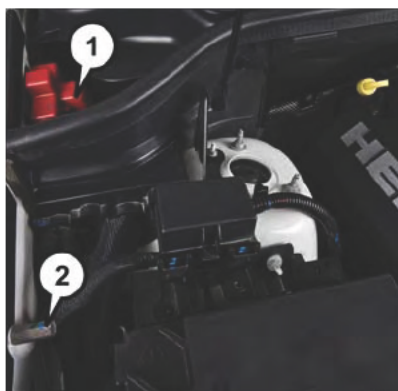

Remote Battery Posts

- 1 — Remote Positive (+) Jump Starting Post
2 — Remote Negative (-) Jump Starting Post
-

WHAT TO DO IN EMERGENCIES

Jump-Starting Procedure

1. Connect the positive (+) end of the jumper cable to the remote positive (+) post of the vehicle with discharged battery.
2. Connect the opposite end of the positive (+) jumper cable to the positive (+) post of the booster battery.
3. Connect the negative(-) end of the jumper cable to the negative (-) post of the booster battery.
4. Connect the opposite end of the negative (-) jumper cable to the remote negative (-) post of the vehicle with the discharged battery.
5. Start the engine in the vehicle that has the booster battery, let the engine idle a few minutes, and then start the engine in the vehicle with the discharged battery.

Once the engine is started, remove the jumper cables in the reverse sequence:

1. Disconnect the negative (-) end of the jumper cable from the remote negative (-) post of the vehicle with the discharged battery.
2. Disconnect the opposite end of the negative (-) jumper cable from the negative (-) post of the booster battery.
3. Disconnect the positive (+) end of the jumper cable from the positive (+) post of the booster battery.
4. Disconnect the opposite end of the positive (+) jumper cable from the remote positive (+) post of the discharged vehicle.
5. Reinstall the protective cover over the remote positive (+) post of the vehicle with the discharged battery.
6. Reinstall the protective plug over the remote negative (-) post of the vehicle with the discharged battery.

NOTE:

If frequent jump-starting is required to start your vehicle you should have the battery and charging system inspected at your authorized dealer.

CAUTION!

- Do not use a portable battery booster pack or any other booster source with a system voltage greater than 12 Volts or damage to the battery, starter motor, alternator or electrical system may occur.
- Failure to follow these procedures could result in damage to the charging system of the booster vehicle or the discharged vehicle.
- Accessories that can be plugged into the vehicle power outlets draw power from the vehicle's battery, even when not in use (e.g., cellular phones, etc.). Eventually, if plugged in long enough, the vehicle's battery discharges sufficiently to degrade battery life and/or prevent the engine from starting.

WHAT TO DO IN EMERGENCIES

WARNING!

- When temperatures are below the freezing point, electrolyte in a discharged battery may freeze. Do not attempt jump-starting because the battery could rupture or explode and cause personal injury. Battery temperature must be brought above the freezing point before attempting a jump-start.
- Take care to avoid the radiator cooling fan whenever the hood is raised. It can start anytime the ignition switch is on. You can be injured by moving fan blades.
- Remove any metal jewelry, such as watch bands or bracelets, that might make an inadvertent electrical contact. You could be severely injured.
- Batteries contain sulfuric acid that can burn your skin or eyes and generate hydrogen gas which is flammable and explosive. Keep open flames or sparks away from the battery.
- Do not allow vehicles to touch each other as this could establish a ground connection and personal injury could result.
- Failure to follow this procedure could result in personal injury or property damage due to battery explosion.
- Do not connect the cable to the negative post (-) of the discharged battery. The resulting electrical spark could cause the battery to explode and could result in personal injury.

MANUAL PARK RELEASE

In order to push or tow the vehicle in cases where the transmission will not shift out of PARK (such as a dead battery), a Manual Park Release is available. The Manual Park Release is located in the center console under an access cover.

Follow these steps to use the Manual Park Release:

1. Lift upward on the access cover, located in the rear portion of the center console to release it from the console hinges.
2. Using a screwdriver or similar tool, push the metal latch in towards the tether strap.



Step 1

WHAT TO DO IN EMERGENCIES

3. While holding the latch in the open position, simultaneously pull upwards on the tether strap until the lever clicks and latches in the released position. The transmission is now out of PARK and the vehicle can be moved.

NOTE:

To prevent the vehicle from rolling unintentionally, firmly apply the parking brake.



Step 3

To Disengage the Manual Park Release Lever:

1. Pull upward on the tether while pushing the release latch towards the tether to unlock the lever.
2. Once the tension has been released and the lever has been unlocked, push the lever all the way down to be sure it is stowed properly and locks into position.
3. Reinstall the access cover by pushing it downward until it is locked into place.

WHAT TO DO IN EMERGENCIES

TOWING A DISABLED VEHICLE

Towing Condition	Wheels OFF the Ground	Rear-Wheel Drive Models	All-Wheel Drive Models With Single-Speed Transfer Case	All-Wheel Drive Models With Two-Speed Transfer Case
Flat Tow	NONE	<p>If Transmission Is Operable:</p> <ul style="list-style-type: none"> • Transmission in NEUTRAL • 30 mph (48 km/h) max speed • 30 miles (48 km) max distance 	NOT ALLOWED	<p>See Instructions:</p> <ul style="list-style-type: none"> • Transmission in PARK • Transfer case in NEUTRAL (N) • Tow in forward direction
Wheel Lift or Dolly Tow	Front	<p>If Transmission Is Operable:</p> <ul style="list-style-type: none"> • Transmission in NEUTRAL • 30 mph (48 km/h) max speed • 30 miles (48 km) max distance 	NOT ALLOWED	NOT ALLOWED
	Rear	OK	NOT ALLOWED	NOT ALLOWED
Flatbed	ALL	BEST METHOD	OK	BEST METHOD

WHAT TO DO IN EMERGENCIES

FREEING A STUCK VEHICLE

- If your vehicle becomes stuck in mud, sand or snow, it can often be moved by a rocking motion. Turn your steering wheel right and left to clear the area around the front wheels. Then shift back and forth between DRIVE and REVERSE while gently pressing the accelerator. Use the least amount of accelerator pedal pressure that will maintain the rocking motion without spinning the wheels or racing the engine.
- Allow the engine to idle with the transmission in NEUTRAL for at least one minute after every five rocking-motion cycles. This minimizes overheating and reduce the risk of transmission failure during prolonged efforts to free a stuck vehicle.

NOTE:

- Shifts between DRIVE and REVERSE can only be achieved at wheel speeds of 5 mph (8 km/h) or less. Whenever the transmission remains in NEUTRAL for more than 2 seconds, you must press the brake pedal to engage DRIVE or REVERSE.
- If your vehicle is equipped with Electronic Stability Control (ESC) then press the "ESC Off" switch, to place the Electronic Stability Control (ESC) system in "Partial Off" mode, before rocking the vehicle.

CAUTION!

Rewving the engine or spinning the wheels too fast may lead to transmission overheating and failure. It can also damage the tires. Do not spin the wheels above 30 mph (48 km/h) while in gear (no transmission shifting occurring).

WARNING!

Fast spinning tires can be dangerous. Forces generated by excessive wheel speeds may cause tire damage or failure. A tire could explode and injure someone. Do not spin your vehicle's wheels faster than 30 mph (48 km/h) when you are stuck. Do not let anyone near a spinning wheel, no matter what the speed.

WHAT TO DO IN EMERGENCIES

EVENT DATA RECORDER (EDR)

This vehicle is equipped with an Event Data Recorder (EDR). The main purpose of an EDR is to record, in certain crash or near crash-like situations, such as an air bag deployment or hitting a road obstacle, data that will assist in understanding how a vehicle's systems performed. The EDR is designed to record data related to vehicle dynamics and safety systems for a short period of time, typically 30 seconds or less. The EDR in this vehicle is designed to record such data as:

- How various systems in your vehicle were operating.
- Whether or not the driver and passenger safety belts were buckled/fastened.
- How far (if at all) the driver was depressing the accelerator and/or brake pedal.
- How fast the vehicle was traveling.

These data can help provide a better understanding of the circumstances in which crashes and injuries occur.

NOTE:

EDR data is recorded by your vehicle only if a non-trivial crash situation occurs; no data is recorded by the EDR under normal driving conditions and no personal data (e.g. name, gender, age, and crash location) is recorded. However, other parties, such as law enforcement, could combine the EDR data with the type of personally identifying data routinely acquired during a crash investigation.

To read data recorded by an EDR, special equipment is required, and access to the vehicle or the EDR is needed. In addition to the vehicle manufacturer, other parties such as law enforcement, that have the special equipment, can read the information if they have access to the vehicle or the EDR.

CAP-LESS FUEL FILL FUNNEL

The funnel for the Cap-Less Fuel System is located on the jacking tool kit. If your vehicle is out of fuel and an auxiliary fuel can is needed, insert the funnel into the filler neck and proceed to fill the vehicle.

MAINTAINING YOUR VEHICLE

OPENING THE HOOD

1. Pull the hood release lever located below the steering wheel at the base of the instrument panel.
2. Reach into the opening beneath the center of the hood and push and hold the safety latch lever to the left while lifting the hood at the same time.



Hood Release

WARNING!

Be sure the hood is fully latched before driving your vehicle. If the hood is not fully latched, it could open when the vehicle is in motion and block your vision. Failure to follow this warning could result in serious injury or death.

MAINTAINING YOUR VEHICLE

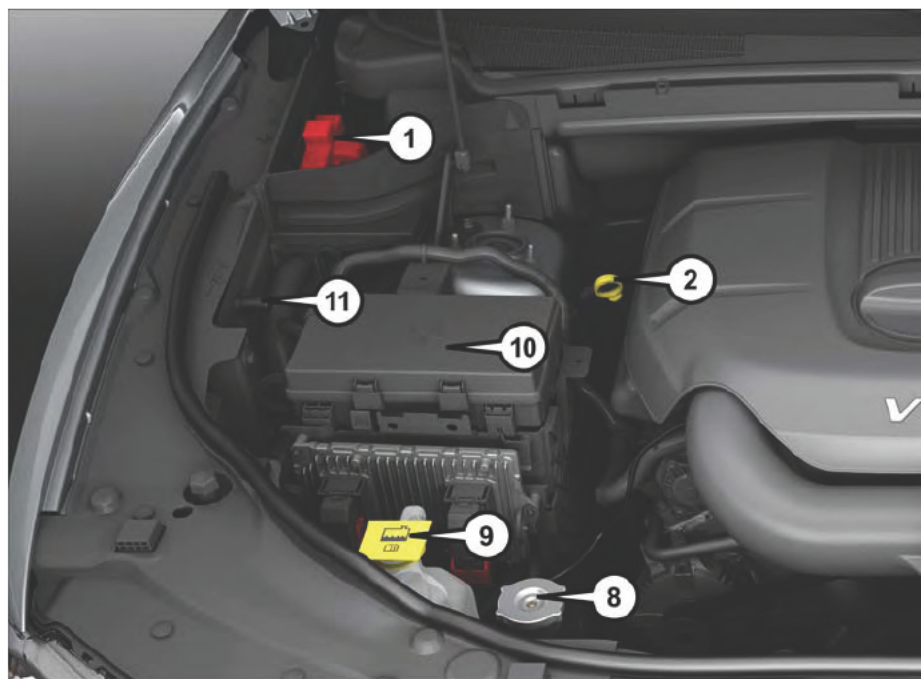

ENGINE COMPARTMENT

3.6L Engine

1. Remote Jump Start Positive Terminal
2. Engine Oil Dipstick
3. Engine Oil Fill
4. Brake Fluid Reservoir
5. Power Steering Fluid Reservoir
6. Air Cleaner Filter

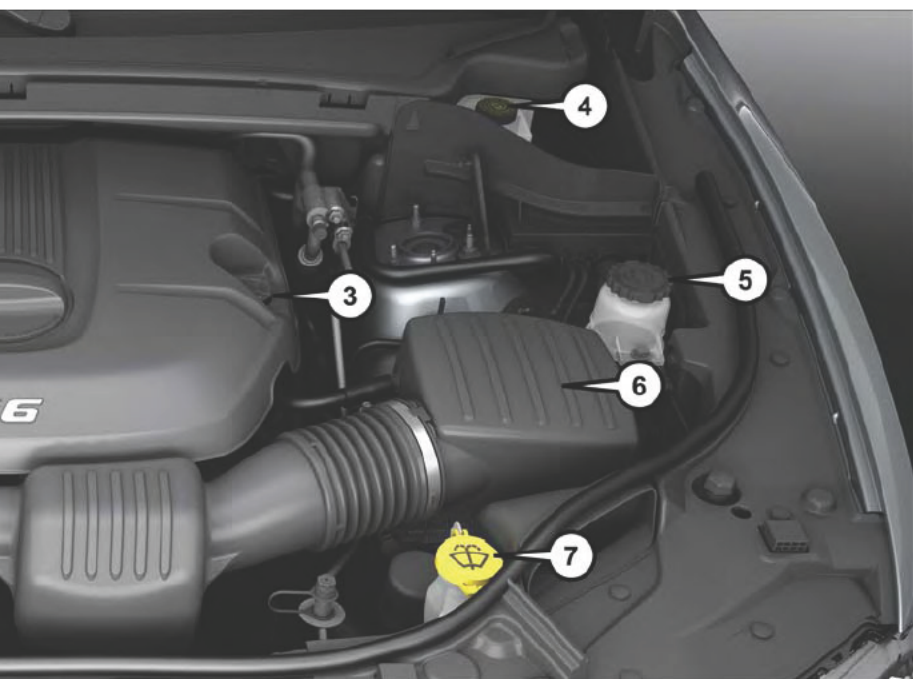

- 7. Washer Fluid Reservoir
- 8. Engine Coolant Pressure Cap
- 9. Engine Coolant Reservoir
- 10. Power Distribution Center (Fuses)
- 11. Remote Jump Start Negative Terminal

MAINTAINING YOUR VEHICLE

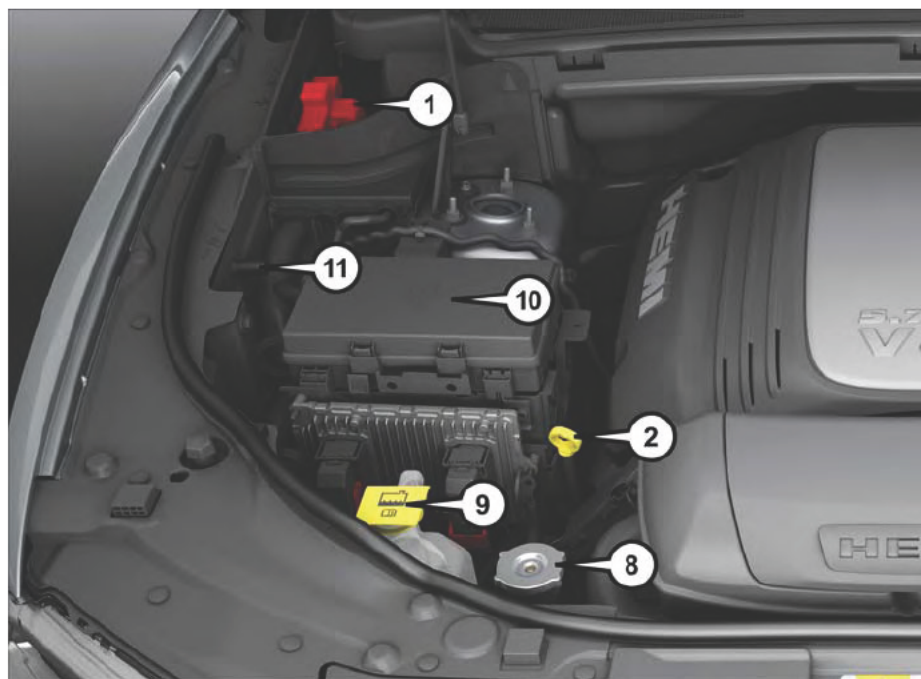

5.7L Engine

1. Remote Jump Start Positive Terminal
2. Engine Oil Dipstick
3. Engine Oil Fill
4. Brake Fluid Reservoir
5. Power Steering Fluid Reservoir
6. Air Cleaner Filter

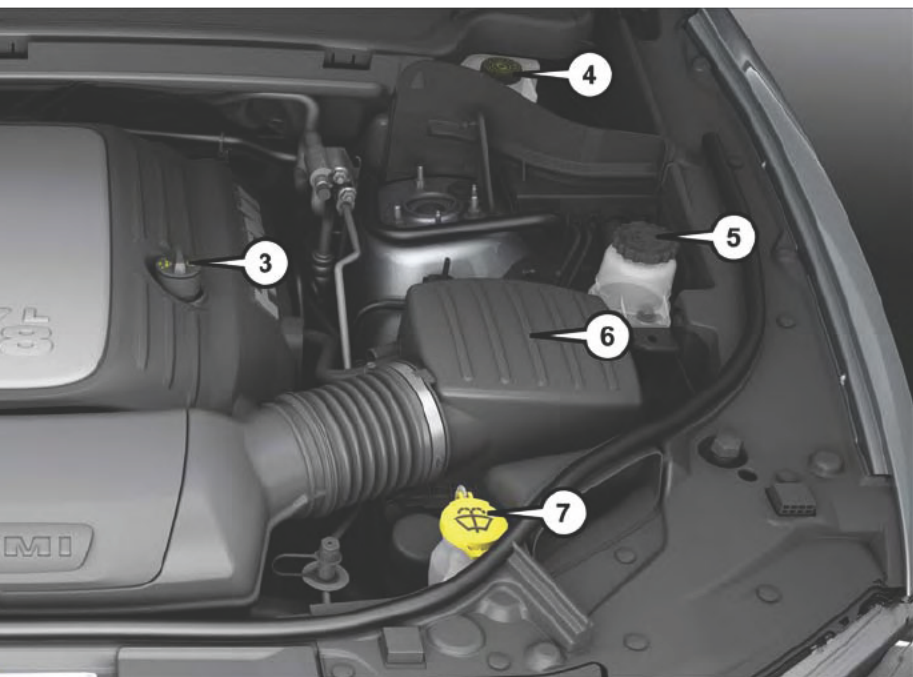

- 7. Washer Fluid Reservoir
- 8. Engine Coolant Pressure Cap
- 9. Engine Coolant Reservoir
- 10. Power Distribution Center (Fuses)
- 11. Remote Jump Start Negative Terminal

MAINTAINING YOUR VEHICLE

FLUID CAPACITIES

	U.S	Metric
Fuel (Approximate)		
3.6L and 5.7L Engines	25 Gallons	94 Liters
Engine Oil With Filter		
3.6L Engine (SAE 5W-20, API Certified)	6 Quarts	5.6 Liters
5.7L Engine (SAE 5W-20, API Certified)	7 Quarts	6.6 Liters
Cooling System *		
3.6L Engine (MOPAR® Antifreeze/Engine Coolant 10 Year/150,000 Mile Formula or equivalent) – Without Trailer Tow Package	10.4 Quarts	9.9 Liters
3.6L Engine (MOPAR® Antifreeze/Engine Coolant 10 Year/150,000 Mile Formula or equivalent) – With Trailer Tow Package	11 Quarts	10.4 Liters
5.7 Liter Engine (MOPAR® Antifreeze/Engine Coolant 10 Year/150,000 Mile Formula or equivalent) – Without Trailer Tow Package	15.4 Quarts	14.6 Liters
5.7 Liter Engine (MOPAR® Antifreeze/Engine Coolant 10 Year/150,000 Mile Formula or equivalent) – With Trailer Tow Package	16 Quarts	15.2 Liters
* Includes heater and coolant recovery bottle filled to MAX level.		

FLUIDS, LUBRICANTS AND GENUINE PARTS

Engine

Component	Fluid, Lubricant, or Genuine Part
Engine Coolant	We recommend you use MOPAR® Antifreeze/Coolant 10 Year/150,000 Mile Formula OAT (Organic Additive Technology) meeting the requirements of Chrysler Material Standard MS-90032.
Engine Oil – 3.6L Engine	We recommend you use API Certified SAE 5W-20 Engine Oil, meeting the requirements of Chrysler Material Standard MS-6395 such as MOPAR®, Pennzoil®, Shell Helix® or equivalent. Refer to your engine oil filler cap for correct SAE grade.
Engine Oil – 5.7L Engine	We recommend you use API Certified SAE 5W-20 Engine Oil, meeting the requirements of Chrysler Material Standard MS-6395 such as MOPAR®, Pennzoil®, Shell Helix® or equivalent. Refer to your engine oil filler cap for correct SAE grade.
Engine Oil Filter	We recommend you use a MOPAR® Engine Oil Filter.
Spark Plugs	We recommend you use MOPAR® Spark Plugs.
Fuel Selection – 3.6L Engine	87 Octane
Fuel Selection – 5.7L Engine	87 Octane Acceptable – 89 Octane Recommended

CAUTION!

- Mixing of engine coolant (antifreeze) other than specified Organic Additive Technology (OAT) engine coolant (antifreeze), may result in engine damage and may decrease corrosion protection. Organic Additive Technology (OAT) engine coolant is different and should not be mixed with Hybrid Organic Additive Technology (HOAT) engine coolant (antifreeze) or any “globally compatible” coolant (antifreeze). If a non-OAT engine coolant (antifreeze) is introduced into the cooling system in an emergency, the cooling system will need to be drained, flushed, and refilled with fresh OAT coolant (conforming to MS.90032), by an authorized dealer as soon as possible.
- Do not use water alone or alcohol-based engine coolant (antifreeze) products. Do not use additional rust inhibitors or antirust products, as they may not be compatible with the radiator engine coolant and may plug the radiator.
- This vehicle has not been designed for use with propylene glycol-based engine coolant (antifreeze). Use of propylene glycol-based engine coolant (antifreeze) is not recommended.

E-85 Flexible Fuel — 3.6L Engine Only

CAUTION!

Only vehicles with the E-85 fuel filler door label or a yellow gas cap can operate on E-85.

Refer to your Owner's Manual on the DVD for further details.

Chassis

Component	Fluid, Lubricant, or Genuine Part
Automatic Transmission	Use only Mopar® ZF 8&9 Speed ATF™ Automatic Transmission Fluid or equivalent. Failure to use the correct fluid may affect the function or performance of your transmission.
Transfer Case – 3.6L Engine	We recommend you use Shell Automatic Transmission Fluid.
Transfer Case – 5.7L Engine	We recommend you use MOPAR® ATF+4® Automatic Transmission Fluid.
Axle Differential (Front-Rear)	We recommend you use MOPAR® GL-5 Synthetic Axle Lubricant SAE 75W-85.
Brake Master Cylinder	We recommend you use MOPAR® DOT 3 Brake Fluid, SAE J1703. If DOT 3, SAE J1703 brake fluid is not available, then DOT 4 is acceptable.
Power Steering Reservoir – 3.6L Engine	We recommend you use MOPAR® Hydraulic Fluid.
Power Steering Reservoir – 5.7L Engine	We recommend you use MOPAR® Power Steering Fluid +4, or MOPAR® ATF+4® Automatic Transmission Fluid.

MAINTAINING YOUR VEHICLE

MAINTENANCE PROCEDURES

For information on the maintenance procedures for your vehicle, please refer to “Maintenance Procedures” in “Maintaining Your Vehicle” in your Owner’s Manual or applicable supplement on the DVD for further details.

MAINTENANCE SCHEDULE

Your vehicle is equipped with an automatic oil change indicator system. The oil change indicator system will remind you that it is time to take your vehicle in for scheduled maintenance.

Based on engine operation conditions, the oil change indicator message will illuminate. This means that service is required for your vehicle. Operating conditions such as frequent short-trips, trailer tow, extremely hot or cold ambient temperatures, and E85 fuel usage will influence when the “Oil Change Required” message is displayed. Severe Operating Conditions can cause the change oil message to illuminate as early as 3,500 miles (5,600 km) since last reset. Have your vehicle serviced as soon as possible, within the next 500 miles (805 km).

Your authorized dealer will reset the oil change indicator message after completing the scheduled oil change.

NOTE:

Under no circumstances should oil change intervals exceed 10,000 miles (16,000 km) or twelve months, whichever comes first.

Severe Duty All Models

- Change Engine Oil at 4000 miles (6,500 km) if the vehicle is operated in a dusty and off road environment. This type of vehicle use is considered Severe Duty.

Once A Month Or Before A Long Trip:

- Check engine oil level
- Check windshield washer fluid level
- Check the tire inflation pressures and look for unusual wear or damage
- Check the fluid levels of the coolant reservoir, brake master cylinder and power steering, and fill as needed.
- Check function of all interior and exterior lights

Required Maintenance

Refer to the Maintenance Schedules on the following pages for required maintenance.

At Every Oil Change Interval As Indicated By Oil Change Indicator System:
• Change oil and filter.
• Rotate the tires. Rotate at the first sign of irregular wear, even if it occurs before the oil indicator system turns on.
• Inspect battery and clean and tighten terminals as required.
• Inspect brake pads, shoes, rotors, drums, hoses and park brake.
• Inspect engine cooling system protection and hoses.
• Inspect exhaust system.
• Inspect engine air cleaner if using in dusty or off-road conditions.

MAINTAINING YOUR VEHICLE

Maintenance Chart

Mileage or time passed (whichever comes first)	20,000	30,000	40,000	50,000	60,000	70,000	80,000	90,000	100,000	110,000	120,000	130,000	140,000	150,000
Or Years:	2	3	4	5	6	7	8	9	10	11	12	13	14	15
Or Kilometers:	32,000	48,000	64,000	80,000	96,000	112,000	128,000	144,000	160,000	176,000	192,000	208,000	224,000	240,000
Additional Inspections														
Inspect the CV joints.		X			X			X			X			X
Inspect front suspension, tie rod ends, and replace if necessary.	X		X		X		X		X		X		X	
Inspect the front and rear axle fluid, change if using your vehicle for police, taxi, fleet, off-road or frequent trailer towing.	X		X		X		X		X		X		X	
Inspect the brake linings, parking brake function.	X		X		X		X		X		X		X	
Inspect transfer case fluid.		X			X			X						X
Additional Maintenance														
Replace engine air filter.		X			X			X			X			X
Replace the air conditioning filter.	X		X		X		X		X		X		X	
Replace spark plugs (3.6L engine). **									X					
Replace spark plugs (5.7L engine). **									X					
Flush and replace the engine coolant at 10 years or 150,000 miles (240,000 km) whichever comes first.									X					X
Change transfer case fluid.														
Inspect and replace PCV valve if necessary.									X					

** The spark plug change interval is mileage based only, yearly intervals do not apply.

WARNING!

- You can be badly injured working on or around a motor vehicle. Do only service work for which you have the knowledge and the right equipment. If you have any doubt about your ability to perform a service job, take your vehicle to a competent mechanic.
- Failure to properly inspect and maintain your vehicle could result in a component malfunction and affect vehicle handling and performance. This could cause an accident.

MAINTAINING YOUR VEHICLE

MAINTENANCE RECORD

	Odometer	Date	Signature, Authorized Service Center
	20,000 Miles (32,000 km) or 2 Years		
	30,000 Miles (48,000 km) or 3 Years		
	40,000 Miles (64,000 km) or 4 Years		
	50,000 Miles (80,000 km) or 5 Years		
	60,000 Miles (96,000 km) or 6 Years		
	70,000 Miles (112,000 km) or 7 Years		
	80,000 Miles (128,000 km) or 8 Years		

	Odometer	Date	Signature, Authorized Service Center
	90,000 Miles (144,000 km) or 9 Years		
	100,000 Miles (160,000 km) or 10 Years		
	110,000 Miles (176,000 km) or 11 Years		
	120,000 Miles (192,000 km) or 12 Years		
	130,000 Miles (208,000 km) or 13 Years		
	140,000 Miles (224,000 km) or 14 Years		
	150,000 Miles (240,000 km) or 15 Years		

FUSES

WARNING!

- When replacing a blown fuse, always use an appropriate replacement fuse with the same amp rating as the original fuse. Never replace a fuse with another fuse of higher amp rating. Never replace a blown fuse with metal wires or any other material. Failure to use proper fuses may result in serious personal injury, fire and/or property damage.
- Before replacing a fuse, make sure that the ignition is off and that all the other services are switched off and/or disengaged.
- If the replaced fuse blows again, contact an authorized dealer.
- If a general protection fuse for safety systems (air bag system, braking system), power unit systems (engine system, gearbox system) or steering system blows, contact an authorized dealer.

Power Distribution Center

The Power Distribution Center is located in the engine compartment near the battery. This center contains cartridge fuses, micro fuses, relays, and circuit breakers. A description of each fuse and component may be stamped on the inside cover, otherwise the cavity number of each fuse is stamped on the inside cover that corresponds to the following chart.

Cavity	Cartridge Fuse	Micro Fuse	Description
F03	60 Amp Yellow	–	Radiator Fan
F05	40 Amp Green	–	Compressor for Air Suspension - If Equipped
F06	40 Amp Green	–	Anti-lock Brakes/Electronic Stability Control Pump
F07	40 Amp Green	–	Starter Solenoid
F08	20 Amp Blue	–	Emission Sensors (Diesel engine only)
F09	30 Amp Pink	–	Diesel Fuel Heater (Diesel engine only)
F10	40 Amp Green	–	Body Controller / Exterior Lighting #2
F11	30 Amp Pink	–	Trailer Tow Electric Brake - If Equipped
F12	40 Amp Green	–	Body Controller #3 / Power Locks
F13	40 Amp Green	–	Blower Motor Front
F14	40 Amp Green	–	Body Controller #4 / Interior Lights #2
F17	30 Amp Pink	–	Headlamp Washer- If Equipped
F19	20 Amp Blue	–	Headrest Solenoid- If Equipped
F20	30 Amp Pink	–	Passenger Door Module
F22	20 Amp Blue	–	Engine Control Module

MAINTAINING YOUR VEHICLE

Cavity	Cartridge Fuse	Micro Fuse	Description
F23	30 Amp Pink	–	Interior Lights #1
F24	30 Amp Pink	–	Driver Door Module
F25	30 Amp Pink	–	Front Wipers
F26	30 Amp Pink	–	Anti-lock Brakes/Stability Control Module/Valves
F28	20 Amp Blue	–	Trailer Tow Backup Lights - If Equipped
F29	20 Amp Blue	–	Trailer Tow Parking Lights - If Equipped
F30	30 Amp Pink	–	Trailer Tow Receptacle - If Equipped
F32	30 Amp Pink	–	Drive Train Control Module
F34	30 Amp Pink	–	Slip Differential Control
F35	30 Amp Pink	–	Sunroof - If Equipped
F36	30 Amp Pink	–	Rear Defroster
F37	25 Amp Clear	–	Rear Blower Motor - If Equipped
F38	30 Amp Pink	–	Power Inverter 115V AC - If Equipped
F39	30 Amp Pink	–	Power Liftgate - If Equipped
F40	–	10 Amp Red	Daytime Running Lights/Headlamp Leveling
F42	–	20 Amp Yellow	Horn
F44	–	10 Amp Red	Diagnostic Port
F46	–	10 Amp Red	Tire Pressure Monitor - If Equipped
F49	–	10 Amp Red	Integrated Central Stack / Climate Control
F50	–	20 Amp Yellow	Air Suspension Control Module - If Equipped
F51	–	15 Amp Blue	Ignition Node Module / Keyless Ignition / Steering Column Lock
F52	–	5 Amp Tan	Battery Sensor
F53	–	20 Amp Yellow	Trailer Tow – Left Turn/Stop Lights - If Equipped
F55	–	10 Amp Red	DTV / DSRC
F56	–	15 Amp Blue	Additional Content (Diesel engine only)
F57	–	15 Amp Blue	HID Headlamps LH - If Equipped
F59	–	10 Amp Red	Purging Pump (Diesel engine only)
F60	–	15 Amp Blue	Transmission Control Module
F61	–	10 Amp Red	Transmission Control Module/PM Sensor (Diesel engine only)
F62	–	10 Amp Red	Air Conditioning Clutch

MAINTAINING YOUR VEHICLE

Cavity	Cartridge Fuse	Micro Fuse	Description
F63	–	20 Amp Yellow	Ignition Coils (Gas), Urea Heater (Diesel)
F64	–	25 Amp Clear	Fuel Injectors / Powertrain
F66	–	10 Amp Red	Sunroof / Passenger Window Switches / Rain Sensor
F67	–	15 Amp Blue	CD / DVD / Bluetooth Hands-free Module - If Equipped
F68	–	20 Amp Yellow	Rear Wiper Motor
F69	–	15 Amp Blue	Spotlight Feed - If Equipped
F70	–	20 Amp Yellow	Fuel Pump Motor
F71	–	30 Amp Green	Audio Amplifier
F73	–	15 Amp Blue	HID Headlamp RH - If Equipped
F74	–	20 Amp Yellow	Brake Vacuum Pump - If Equipped
F76	–	10 Amp Red	Anti-lock Brakes/Electronic Stability Control
F77	–	10 Amp Red	Drivetrain Control Module/Front Axle Disconnect Module
F78	–	10 Amp Red	Engine Control Module / Electric Power Steering - If Equipped
F80	–	10 Amp Red	Universal Garage Door Opener / Compass / Anti-Intrusion Module
F81	–	20 Amp Yellow	Trailer Tow Right Turn/Stop Lights
F82	–	10 Amp Red	Steering Column Control Module/ Cruise Control
F83	–	10 Amp Red	Fuel Door
F84	–	15 Amp Blue	Switch Bank/Instrument Cluster
F85	–	10 Amp Red	Airbag Module
F86	–	10 Amp Red	Airbag Module
F87	–	10 Amp Red	Air Suspension – If Equipped / Trailer Tow / Steering Column Control Module
F88	–	15 Amp Blue	Instrument Panel Cluster
F90/F91	–	20 Amp Yellow	Power Outlet (Rear seats) Selectable
F92	–	10 Amp Red	Rear Console Lamp - If Equipped
F93	–	20 Amp Yellow	Cigar Lighter
F94	–	10 Amp Red	Shifter / Transfer Case Module
F95	–	10 Amp Red	Rear Camera / ParkSense®
F96	–	10 Amp Red	Rear Seat Heater Switch / Flashlamp Charger - If Equipped
F97	–	20 Amp Yellow	Rear Heated Seats & Heated Steering Wheel - If Equipped
F98	–	20 Amp Yellow	Front Heated Seats - If Equipped

MAINTAINING YOUR VEHICLE

Cavity	Cartridge Fuse	Micro Fuse	Description
F99	–	10 Amp Red	Climate Control / Driver Assistance Systems Module
F100	–	10 Amp Red	Active Damping - If Equipped
F101	–	15 Amp Blue	Electrochromatic Mirror/Smart High Beams - If Equipped
F103	–	10 Amp Red	Cabin Heater (Diesel Engine Only)/ Rear HVAC
F104	–	20 Amp Yellow	Power Outlets (Instrument Panel/ Center Console)

CAUTION!

- When installing the power distribution center cover, it is important to ensure the cover is properly positioned and fully latched. Failure to do so may allow water to get into the power distribution center and possibly result in an electrical system failure.
- When replacing a blown fuse, it is important to use only a fuse having the correct amperage rating. The use of a fuse with a rating other than indicated may result in a dangerous electrical system overload. If a properly rated fuse continues to blow, it indicates a problem in the circuit that must be corrected.

TIRE PRESSURES

Check the inflation pressure of each tire, including the spare tire (if equipped), at least monthly and inflate to the recommended pressure for your vehicle.

The tire pressures recommended for your vehicle are found on the "Tire and Loading Information" label located on the driver's side door opening.

NOTE:

Refer to the Owner's Manual on the DVD for more information regarding tire warnings and instructions.



Tire And Loading Information Location
(Example)

MAINTAINING YOUR VEHICLE

WARNING!

- Overloading of your tires is dangerous. Overloading can cause tire failure, affect vehicle handling, and increase your stopping distance. Use tires of the recommended load capacity for your vehicle. Never overload them.
- Improperly inflated tires are dangerous and can cause collisions. Under-inflation increases tire flexing and can result in over-heating and tire failure. Over-inflation reduces a tire's ability to cushion shock. Objects on the road and chuck holes can cause damage that results in tire failure. Unequal tire pressures can cause steering problems. You could lose control of your vehicle. Over-inflated or under-inflated tires can affect vehicle handling and can fail suddenly, resulting in loss of vehicle control. Always drive with each tire inflated to the recommended cold tire inflation pressure.

ADDING FUEL

1. Press the fuel filler door release switch (located under the headlamp switch).



Fuel Filler Door Release

MAINTAINING YOUR VEHICLE

2. Open the fuel filler door.

NOTE:

In certain cold conditions, ice may prevent the fuel door from opening. If this occurs, lightly push on the fuel door to break the ice buildup and re-release the fuel door using the inside release button. Do not pry on the door.

3. There is no fuel filler cap. A flapper door inside the pipe seals the system.
4. Insert the fuel nozzle fully into the filler pipe, the nozzle opens and holds the flapper door while refueling.
5. Fill the vehicle with fuel, when the fuel nozzle "clicks" or shuts off the fuel tank is full.
6. Remove the fuel nozzle and close the fuel door.



Fuel Filler

Fuel Door Emergency Release

- To manually open the fuel door, remove the storage bin located in the left rear cargo area.
 1. Push down on inboard edge. This will pop up the outboard edge.
 2. Grab popped up outboard edge with other hand to disengage snaps.
 3. Remove storage bin.



Storage Bin Location

MAINTAINING YOUR VEHICLE

- Pull the release cable located in the storage bin opening.



Emergency Release Cable

SPARE TIRES — IF EQUIPPED

NOTE:

For vehicles equipped with Tire Service Kit instead of a spare tire, please refer to “Tire Service Kit” in “What To Do In Emergencies” on your DVD for further information.

CAUTION!

Because of the reduced ground clearance, do not take your vehicle through an automatic car wash with a compact or limited-use temporary spare installed. Damage to the vehicle may result.

Spare Tire Matching Original Equipped Tire And Wheel — If Equipped

Your vehicle may be equipped with a spare tire and wheel equivalent in look and function to the original equipment tire and wheel found on the front or rear axle of your vehicle. This spare tire may be used in the tire rotation for your vehicle. If your vehicle has this option, refer to an authorized tire dealer for the recommended tire rotation pattern.

Compact Spare Tire — If Equipped

The compact spare is for temporary emergency use only. You can identify if your vehicle is equipped with a compact spare by looking at the spare tire description on the Tire and Loading Information Placard located on the driver's side door opening or on the sidewall of the tire. Compact spare tire descriptions begin with the letter “T” or “S” preceding the size designation. Example: T145/80D18 103M.

T, S = Temporary Spare Tire

Since this tire has limited tread life, the original equipment tire should be repaired (or replaced) and reinstalled on your vehicle at the first opportunity.

Do not install a wheel cover or attempt to mount a conventional tire on the compact spare wheel, since the wheel is designed specifically for the compact spare tire. Do not install more than one compact spare tire and wheel on the vehicle at any given time.

MAINTAINING YOUR VEHICLE

WARNING!

Compact spares are for temporary emergency use only. With these spares, do not drive more than 50 mph (80 km/h). Temporary use spares have limited tread life. When the tread is worn to the tread wear indicators, the temporary use spare tire needs to be replaced. Be sure to follow the warnings, which apply to your spare. Failure to do so could result in spare tire failure and loss of vehicle control.

Full Size Spare — If Equipped

The full size spare is for temporary emergency use only. This tire may look like the originally equipped tire on the front or rear axle of your vehicle, but it is not. This spare tire may have limited tread life. When the tread is worn to the tread wear indicators, the temporary use full size spare tire needs to be replaced. Since it is not the same as your original equipment tire, replace (or repair) the original equipment tire and reinstall on the vehicle at the first opportunity.

Limited-Use Spare — If Equipped

The limited-use spare tire is for temporary emergency use only. This tire is identified by a label located on the limited-use spare wheel. This label contains the driving limitations for this spare. This tire may look like the original equipped tire on the front or rear axle of your vehicle, but it is not. Installation of this limited-use spare tire affects vehicle handling. Since it is not the same as your original equipment tire, replace (or repair) the original equipment tire and reinstall on the vehicle at the first opportunity.

WARNING!

Limited-use spares are for emergency use only. Installation of this limited-use spare tire affects vehicle handling. With this tire, do not drive more than the speed listed on the limit-use spare wheel. Keep inflated to the cold tire inflation pressures listed on your Tire and Loading Information Placard located on the driver's side B-Pillar or the rear edge of the driver's side door. Replace (or repair) the original equipment tire at the first opportunity and reinstall it on your vehicle. Failure to do so could result in loss of vehicle control.

WHEEL AND WHEEL TRIM CARE

All wheels and wheel trim, especially aluminum and chrome plated wheels, should be cleaned regularly with a mild soap and water to prevent corrosion.

To remove heavy soil and/or excessive brake dust, use MOPAR® Wheel Cleaner or equivalent or select a non-abrasive, non-acidic cleaner.

MAINTAINING YOUR VEHICLE

CAUTION!

Do not use scouring pads, steel wool, a bristle brush, or metal polishes. Do not use oven cleaner. These products may damage the wheel's protective finish. Avoid automatic car washes that use acidic solutions or harsh brushes that may damage the wheel's protective finish. Only MOPAR® Wheel Cleaner or equivalent is recommended.

REPLACEMENT BULBS

Interior Bulbs

	Bulb Number
Glove Box Lamp	194
Grab Handle Lamp	LO02825W5W
Overhead Console Reading Lamps	VT4976
Visor Vanity Lamp	V26377
Rear Cargo Lamp	214-2
Underpanel Courtesy Lamps	906
Instrument Cluster (General Illumination)	103
Telltale/Hazard Lamp	74

Exterior Bulbs

	Bulb Number
Low Beam/High Beam (Bi-Xenon) Headlamps	D3S (Service at Authorized Dealer)
Low Beam/High Beam/Daytime Running Lamp (DRL) Bi-Halogen Headlamps (Base)	HIR2LL
Low Beam/High Beam (Bi-Halogen) Headlamps (Uplevel)	HIR2LL
Front Park/Turn Signal Lamps (Base)	3157NAK
Front Turn Signal Lamps (Uplevel & Premium)	3157NAK
Front Park Lamp/Daytime Running Lamp (Uplevel & Premium)	LED (Serviced at Authorized Dealer)
Front Side Marker Lamps	LED (Serviced at Authorized Dealer)
Front Fog Lamps	H11
Rear Tail Lamps/Sidemarkers Lamps	LED (Serviced at Authorized Dealer)
Rear Stop/Turn Signal Lamps	LED (Serviced at Authorized Dealer)
Rear Liftgate Tail Lamps	LED (Serviced at Authorized Dealer)
Rear Backup Lamps	921 (W16W)
Rear License Lamps	LED (Serviced at Authorized Dealer)
Center High-Mounted Stop Lamp (CHMSL)	LED (Serviced at Authorized Dealer)

CUSTOMER ASSISTANCE

CHRYSLER GROUP LLC CUSTOMER CENTER

P.O. Box 21-8004 Auburn Hills, MI 48321-8004 Phone: 1-800-423-6343

CHRYSLER CANADA INC. CUSTOMER CENTER

P.O. Box 1621 Windsor, Ontario N9A 4H6 Phone: 1-800-465-2001 (English) Phone: 1-800-387-9983 (French)

ASSISTANCE FOR THE HEARING IMPAIRED

To assist customers who have hearing difficulties, the manufacturer has installed special TDD (Telecommunication Devices for the Deaf) equipment at its customer center. Any hearing or speech impaired customer, who has access to a TDD or a conventional teletypewriter (TTY) in the United States, can communicate with the manufacturer by dialing 1-800-380-CHRY. Canadian residents with hearing difficulties that require assistance can use the special needs relay service offered by Bell Canada. For TTY teletypewriter users, dial 711 and for Voice callers, dial 1-800-855-0511 to connect with a Bell Relay Service operator.

WARNING!

Engine exhaust, some of its constituents, and certain vehicle components contain, or emit, chemicals known to the State of California to cause cancer and birth defects, or other reproductive harm. In addition, certain fluids contained in vehicles and certain products of component wear contain, or emit, chemicals known to the State of California to cause cancer and birth defects, or other reproductive harm.

PUBLICATIONS ORDERING

- If you are the first registered retail owner of your vehicle, you may obtain a complimentary printed copy of the Owner's Manual, Navigation/Uconnect® Manuals or Warranty Booklet. United States customers may visit the Dodge Contact Us page at www.dodge.com scroll to the bottom of the page and select the "Contact Us" link, then select the "Owner's Manual and Glove Box Material" from the left menu. You may also obtain a complimentary copy by calling 1-800-423-6343 (U.S.) or 1-800-387-1143 (Canada).
- Replacement User Guide kits or DVDs or, if you prefer, additional printed copies of the Owner's Manual, Warranty Booklet or Radio Manuals may be purchased by visiting www.techauthority.com or by calling 1-800-890-4038 (U.S.) or 1-800-387-1143 (Canada). Visa, Master Card, American Express and Discover orders are accepted. If you prefer mailing your order, please call the above numbers for an order form.

NOTE:

- A street address is required when ordering manuals (no P.O. Boxes).
- The Owner's Manual and User Guide electronic files are also available on the Chrysler, Jeep, Ram Truck, Dodge and SRT websites.
- Click on the "For Owners" tab, select "Owner/Service Manuals", then select your desired model year and vehicle from the drop down lists.

REPORTING SAFETY DEFECTS IN THE UNITED STATES

If you believe that your vehicle has a defect that could cause a collision or cause injury or death, you should immediately inform the National Highway Traffic Safety Administration (NHTSA) in addition to notifying the manufacturer.

If NHTSA receives similar complaints, it may open an investigation, and if it finds that a safety defect exists in a group of vehicles, it may order a recall and remedy campaign. However, NHTSA cannot become involved in individual problems between you, your authorized dealer and the manufacturer.

To contact NHTSA, you may either call the Auto Safety Hotline toll free at 1-888-327-4236 (TTY: 1-800-424-9153), or go to <http://www.safercar.gov>; or write to: Administrator, NHTSA, 1200 New Jersey Avenue, SE., West Building, Washington, D.C. 20590. You can also obtain other information about motor vehicle safety from <http://www.safercar.gov>.

In Canada

If you believe that your vehicle has a safety defect, you should contact the Customer Service Department immediately. Canadian customers who wish to report a safety defect to the Canadian government should contact Transport Canada, Motor Vehicle Defect Investigations and Recalls at 1-800-333-0510 or go to <http://www.tc.gc.ca/roadsafety/>.

French Canadian customers who wish to report a safety defect to the Canadian government should contact Transport Canada, Motor Vehicle Defect Investigations and Recalls at 1-800-333-0510 or go to <http://www.tc.gc.ca/securiteroutiere/>.

MOPAR® ACCESSORIES

AUTHENTIC ACCESSORIES BY MOPAR®

- The following highlights just some of the many Authentic Dodge Accessories by Mopar® featuring a fit, finish, and functionality specifically for your Dodge Durango.
- In choosing Authentic Accessories you gain far more than expressive style, premium protection, or extreme entertainment, you also benefit from enhancing your vehicle with accessories that have been thoroughly tested and factory-approved.
- For the full line of Authentic Dodge Accessories by Mopar®, visit your local dealership or online at mopar.com for U.S. residents and mopar.ca for Canadian residents.

NOTE:

All parts are subject to availability.

EXTERIOR:

- Molded Running Boards
- Tubular Side Steps
- Molded Splash Guards
- Front End Cover
- Wheels
- Chrome Accents
- Chrome Front Air Deflector

INTERIOR:

- Heated Seats
- Door Sill Guards
- Molded Cargo Tray
- All-Weather Mats
- Katzkin Leather Interiors
- Bright Pedal Kit
- Premium Carpet Floor Mats
- Ambient Lighting

ELECTRONICS:

- Mopar® Web (WiFi)
- Rear View Camera
- Park Distance Sensors
- Electronic Vehicle Tracking System
- Remote Start

CARRIERS:

- Hitch-Mount Bike Carrier
- Roof Box Cargo Carrier
- Roof Mount Bike Carrier
- Roof Rack
- Hitch Receiver
- Cargo Basket
- Roof Mount Ski and Snowboard Carrier
- Roof Mount Water Sports Carrier

FREQUENTLY ASKED QUESTIONS

FREQUENTLY ASKED QUESTIONS

GETTING STARTED

How do I install my LATCH Equipped Child Seat? pg. 19

How do I program my Front Seat Memory? pg. 28

OPERATING YOUR VEHICLE

How does the Automatic Climate Control operate? pg. 53

ELECTRONICS

Which radio is in my vehicle?

- Uconnect® 5.0 pg. 80
- Uconnect® 8.4A pg. 92
- Uconnect® 8.4AN pg. 118

How do I activate the Audio Jack?

- Uconnect® 5.0 pg. 83
- Uconnect® 8.4A/8.4AN pg. 98

How do I set the clock on my radio?

- Uconnect® 5.0 pg. 80
- Uconnect® 8.4A/8.4AN pg. 92

How do I use the Navigation feature?

- Uconnect® 8.4A/8.4AN pg. 100

How do I pair my mobile phone via Bluetooth® with the UConnect® Hands-Free Voice Activation System? pg. 134

How do I use my USB port to listen to audio through my touchscreen radio?

- Uconnect® 5.0 pg. 83
- Uconnect® 8.4A/8.4AN pg. 98

How do I configure my Universal Garage Door Opener (HomeLink)? pg. 146

How do I improve the Bluetooth® performance of my Uconnect® System? pg. 141

UTILITY

How do I know how much I can tow with my Dodge Durango? pg. 154



FREQUENTLY ASKED QUESTIONS

WHAT TO DO IN EMERGENCIES

What do I do if my TPMS warning light is blinking? pg. 161

How do I change a flat tire? pg. 169

How do I Jump-Start my vehicle? pg. 180

MAINTAINING YOUR VEHICLE

Where is my Fuse Block located? pg. 199

What type of oil do I use? pg. 192

How often should I change my engine's oil? pg. 194

What should my tire pressure be set at? pg. 202

- Access
 - Uconnect®63
- Access, Uconnect®63
- Adaptive Cruise Control (ACC)
 - (Cruise Control).43
- Adding Engine Coolant (Antifreeze) . .194
- Adding Fuel203
- Adding Washer Fluid194
- Air Bag
 - Advanced Front Air Bag16
 - Advance Front Air Bag16
 - Air Bags16
 - Air Bag Warning Light16, 165
 - Driver Knee Air Bag18
 - Front Air Bag16
 - Passenger Knee Air Bag18
 - Rollover16
 - Side Air bags18
 - Side Impact Curtains18
 - Side Impacts16
- Air bag, Side.16
- Air Cleaner, Engine (Engine Air Cleaner Filter).194
- Air Conditioner Maintenance194
- Air Conditioning.53, 55
- Air Conditioning Refrigerant194
- Air Conditioning System194
- Alarm
 - Arm The System15
 - Disarm The System15
 - Vehicle Security Alarm15
- Alarm (Security Alarm)15, 167
- All Wheel Drive (AWD)152
- Antifreeze (Engine Coolant) . . .192, 194
 - Disposal194
- Anti-Lock Brake System (ABS) . . .165
- APP
 - Uconnect® Access66
- Appearance Care194
- Arming System (Security Alarm) . . .15
- Assistance Towing161
- Automatic Dimming Mirror49
- Automatic Headlights40
- Automatic High Beams40
- Automatic Temperature Control (ATC) .53
 - SYNC Temperature Button56
- Automatic Transmission
 - Fluid Type193
- Axle Fluid.193
- Back-Up Camera57
- Battery180, 194
 - Charging System Light164
- Blind Spot Monitoring.58
- Body Mechanism Lubrication194
- Brake Fluid193
- Brakes194
- Brake System194
 - Master Cylinder194
 - Warning Light162
- Break-In Recommendations, New Vehicle38
- Bulb Replacement.207
- Calibration, Compass143
- Capacities, Fluid192
- Caps, Filler
 - Fuel186
 - Oil (Engine)194
- Cargo Compartment
 - Luggage Carrier154
- Car Washes194
- Change Oil Indicator165
- Changing A Flat Tire169
- Charging System Light.164
- Check Engine Light (Malfunction Indicator Light)163
- Child Restraint19, 20
 - Arm Rest Tether22
- Child Restraints
 - Center Seat LATCH21
 - Child Restraints20
 - Child Tether Anchorage Locations . .22
 - Locating The LATCH Anchorages . .20
 - Lower Anchors And Tethers For Children19, 20
- Cleaning
 - Wheels194
 - Windshield Wiper Blades194
- Climate Control53
- Clock80
- Clock Setting.80
- Cluster Warning/Indicator Lights
 - Air Bag Warning Light165
 - Brake Warning Light162

- Electronic Speed Control ON Indicator 167
- Electronic Speed Control SET Indicator 167
- Electronic Stability Control (ESC)
 - OFF Indicator Light 167
 - Front Fog Light Indicator 167
 - High Beam Indicator 167
 - Park/Headlight ON Indicator . . . 167
 - Turn Signal Indicator 166
 - Vehicle Security Light 167
- Clutch 194
- Clutch Fluid 194
- Compact Spare Tire 205
- Compass Calibration 143
- Cooling System. 194
 - Adding Coolant (Antifreeze) . . . 194
 - Coolant Capacity 192
 - Coolant Level 194
 - Disposal of Used Coolant 194
 - Drain, Flush, and Refill 194
 - Inspection 194
 - Points to Remember 194
 - Pressure Cap 194
 - Selection of Coolant (Antifreeze) 192, 194
 - Corrosion Protection 194
- Cruise Control (Speed Control) 41
- Cruise Light 41
- Customer Assistance. 208
- Customer Programmable Features . . 145
- Defects, Reporting 209
- Dimmer Control 40
- Dimmer Switch, Headlight 40
- Disabled Vehicle Towing 161
- Disarming, Security System. 15
- Discharged Battery. 180
- Disposal
 - Antifreeze (Engine Coolant) . . . 194
- Driver Cockpit 7
- Driver Information Display
 - DID 167
 - Instrument Cluster Display . . . 167
 - Programmable Features 144
- Driver Information Display (DID)
 - Display 143
 - Driver Information Display (DID) . 145
- Selectable Menu Items 145
- ECO. 143
- Economy (Fuel) Mode 52
- Electronically Shifted Transfer Case. 152
- Electronics
 - Your Vehicle's Sound System 60
- Electronic Speed Control (Cruise Control) 41
- Electronic Stability Control (ESC) . . 164
- Electronic Stability Control (ESC)
 - OFF Indicator 167
- Electronic Throttle Control Warning Light. 165
- Emergency, In Case of
 - Jacking 169
 - Overheating 168
 - Towing 161
- Engine
 - Air Cleaner 194
 - Break-In Recommendations 38
 - Checking Oil Level 194
 - Compartment 188
 - Cooling 194
 - Fuel Requirements 192
 - Malfunction Indicator (Check Engine) 163
 - Oil 192, 194
 - Oil Filler Cap 194
 - Oil Selection 192, 194
 - Overheating 168
 - Starting 13
 - Stopping 13
- Event Data Recorder. 186
- Exhaust System 194
- Exterior Lights 207
- FAQ 211
- Filters
 - Air Cleaner 194
 - Engine Oil 194
 - Engine Oil Disposal 194
- Flashers
 - Turn Signal 166
- Fluid Capacities 192
- Fluids. 193
- Fluids, Lubricants and Genuine Parts . 192
- Fog Lights 40, 167

- Folding Front Passenger Seat30
- Folding Rear Seat31, 32
- Forward Collision Warning47
- Four Wheel Drive152
 - Operation152
 - Systems152
- Four Wheel Drive Operation152
- Freeing A Stuck Vehicle185
- Frequently Asked Questions211
- Fuel
 - Economy Mode52
 - Filler Door Emergency Release . .204
 - Requirements192
 - Specifications192
 - Tank Capacity192
- Fuses199
- General Maintenance194
- Glass Cleaning194
- Hands-Free Phone (Uconnect®) . . .132
- Headlights
 - Automatic40
 - Cleaning194
 - Dimmer Switch40
 - High Beam39
 - High Beam/Low Beam Select
Switch39
- Heated Mirrors56
- Heated Seats33
- Heated Steering Wheel35
- High Beam Indicator167
- High Beam/Low Beam Select (Dimmer)
Switch39
- HomeLink® (Garage Door Opener) .146
- Hood Release187
- Identifying Your Radio62
- Instrument Cluster8
 - Indicators8
- Instrument Cluster Indicator Lights .166
- Instrument Panel Cover194
- Instrument Panel Lens Cleaning . .194
- Interior and Instrument Lights7
- Interior Appearance Care194
- Intermittent Wipers (Delay Wipers) .39
- Introduction3
- In Vehicle Features
 - Uconnect® Access70
- Inverter Outlet (115V)149
- Inverter, Power149
- iPod®/USB/MP3 Control
 - Bluetooth® Streaming
Audio83, 98, 125, 132
- Jacking Instructions173
- Jack Location169
- Jack Operation169, 173
- Jump Starting180
- Key Fob10
 - Arm The Alarm15
 - Disarm The Alarm15
 - Lock The Doors10
 - Unlock The Doors10
- Keyless Enter-N-Go10
 - Lock/Unlock12, 13
 - Starting/Stopping13
- Keyless Enter-N-Go™11
 - Passive Entry11
- Lane Change Assist38
- Lap/Shoulder Belts15
- LATCH (Lower Anchors and Tether for
Children)21
- Liftgate10
- Liftgate, Power10
- Lights
 - Fog167
 - Headlights40
 - High Beam Indicator167
 - Hill Descent Control Indicator .167
 - Low Fuel166
 - Security Alarm167
- Locks
 - Liftgate, Tailgate10
- Lubrication, Body194
- Luggage Rack (Roof Rack)154
- Maintenance Free Battery194
- Maintenance, General194
- Maintenance Procedures194
- Maintenance Record198
- Maintenance Schedule194

INDEX

- Malfunction Indicator Light
 - (Check Engine)163
- Master Cylinder (Brakes)194
- Memory Seat28
- Mirrors
 - Automatic Dimming49
 - Heated56
- MOPAR® Accessories210
- Navigation100, 127
- New Vehicle Break-In Period38
- Oil Change Indicator165
- Oil Change Indicator, Reset165
- Oil, Engine167, 194
 - Capacity192
 - Change Interval194
 - Checking194
 - Disposal194
 - Filter194
 - Filter Disposal194
 - Materials Added to194
 - Recommendation192, 194
 - Viscosity192, 194
- Oil Filter, Selection194
- Outlet
 - Power150
- Overheating, Engine168
- Paint Care194
- Panic Alarm10
- ParkSense® System, Rear57
- Phone, Hands-Free (Uconnect®) . . .132
- Phone (Uconnect®)132
- Placard, Tire and Loading Information .202
- Power
 - Distribution Center (Fuses) . . .199
 - Glass Sunroof58
 - Inverter149
 - Lift Gate10
 - Outlet (Auxiliary Electrical
 - Outlet)150
 - Seats27
 - Steering193
- Preparation for Jacking172
- Pretensioners
 - Seat Belts15
- Programmable Electronic Features .145
- Purchase Apps
 - Uconnect® Access67
- Rain Sensitive Wiper System39
- Rear Camera57
- Rear Cross Path58
- Rear ParkSense System57
- Rear Seat, Folding31
- Reclining Front Seats30
- Recreational Towing156
 - Shifting into Transfer Case
 - Neutral (N)158
 - Shifting out of Transfer Case
 - Neutral (N)160
- Refrigerant194
- Remote Keyless Entry (RKE)
 - Arm The Alarm15
 - Disarm The Alarm15
 - Lock The Doors10
 - Remote Keyless Entry (RKE) . . .10
 - Unlock The Doors10
- Remote Starting System10, 11
- Replacement Bulbs207
- Reporting Safety Defects209
- Roll Over Warning5
- Roof Rack (Luggage Rack)154
- Schedule, Maintenance194
- Seat Belt Maintenance194
- Seat Belts15
 - Adjustable Shoulder Belt15
 - Pretensioners15
 - Seat Belt Warning16
- Seats27, 29
 - Adjustment29
 - Folding Front Passenger30
 - Heated33
 - Manual29
 - Memory28
 - Power27
 - Rear Folding31, 32
- Security Alarm167
 - Arm The System15
 - Disarm The System15
 - Security Alarm15
- Set Up Your Via Mobile Profile
 - Uconnect®66
- Signals, Turn38, 166

- Sirius Satellite Radio95, 122
- SIRIUS Travel Link.131
- Spare Tire170, 205, 206
- Spark Plugs192, 193
- Speed Control
 - Accel/Decel41
 - Distance Setting (ACC Only)42
 - Mode Setting (ACC Only)45
- Speed Control (Cruise Control)41
- Starting
 - Remote11
- Steering
 - Tilt Column36
 - Wheel, Heated35
- Steering Wheel Audio Controls142
- Sun Roof58
- Supplemental Restraint System -
 - Airbag.16
- Temperature Control, Automatic (ATC) . .53
- Tether Anchor, Child Restraint23
- Text Messaging84, 140
- Tilt Steering Column.36
- Tires
 - Air Pressure202
 - Changing169
 - Compact Spare205
 - Jacking169
 - Pressure Warning Light161
 - Spare Tire170
- Towing
 - Disabled Vehicle184
 - Guide154
 - Recreational156
 - Weight154
- Towing Vehicle Behind a Motorhome . .156
- Trailer Towing Guide154
- Trailer Weight.154
- Transfer Case
 - Electronically Shifted152
 - Fluid193
- Transmission
 - Fluid193, 194
 - Maintenance194
- Turn Signals38, 166
- Uconnect®
 - Access63
 - Set Up Your Via Mobile Profile . . .66
 - Using Access68
 - Via Mobile Apps79
 - Uconnect® 5.080
 - Uconnect® 8.4A92
 - Changing The Volume138
 - Helpful Tips For Bluetooth141
 - Mute138
 - Phonebook138
 - Transfer Ongoing Call Between
 - Handset And Vehicle138
 - Voice Recognition Tips138
 - Uconnect® 8.4AN118
 - At A Glance118
 - Radio121
 - Uconnect® Access.63
 - APP66
 - In Vehicle Features70
 - Purchase Apps67
 - Uconnect® (Hands-Free Phone)
 - Making A Phone Call137
 - Receiving A Call138
 - Uconnect® Voice Command . . .85, 104
 - Using Access
 - Uconnect®68
- Via Mobile Apps
 - Uconnect®79
 - Voice Command85, 104
 - Voice Recognition System (VR) .85, 104
- Warning, Roll Over5
- Warnings and Cautions19
- Washer
 - Adding Fluid194
 - Rear39
- Washers, Headlight38
- Washers, Windshield39
- Washing Vehicle194
- Wheel and Wheel Trim.194
- Wheel and Wheel Trim Care . . .194, 206
- Wind Buffeting.59



INDEX

Windshield Washers39	Wiper Blade Replacement194
Fluid167	Wiper, Rear39
Windshield Wiper Blades194	Wipers, Intermittent39
Windshield Wipers39	Wipers, Rain Sensitive.39



NOTES

DODGE.COM (U.S.) DODGE.CA (CANADA)

This guide has been prepared to help you get quickly acquainted with your new Dodge and to provide a convenient reference source for common questions. However, it is not a substitute for your Owner's Manual.

For complete operational instructions, maintenance procedures and important safety messages, please consult your Owner's Manual, Navigation/Uconnect® Manuals and other Warning Labels in your vehicle.

Not all features shown in this guide may apply to your vehicle. For additional information on accessories to help personalize your vehicle, visit www.mopar.com (U.S.), www.mopar.ca (Canada) or your local Dodge dealer.



DRIVING AND ALCOHOL

Drunken driving is one of the most frequent causes of accidents. Your driving ability can be seriously impaired with blood alcohol levels far below the legal minimum. If you are drinking, don't drive. Ride with a designated non-drinking driver, call a cab, a friend, or use public transportation.

WARNING!

Driving after drinking can lead to an accident. Your perceptions are less sharp, your reflexes are slower, and your judgment is impaired when you have been drinking. Never drink and then drive.

DOWNLOAD A FREE
ELECTRONIC COPY OF THE OWNER'S
MANUAL AND WARRANTY BOOKLET

BY VISITING:

WWW.DODGE.COM/EN/OWNERS/MANUALS
OR WWW.DODGE.COM/EN/WARRANTY (U.S.);
WWW.OWNERS.MOPAR.CA/EN (CANADA).

DODGE AND DURANGO ARE REGISTERED TRADEMARKS
OF CHRYSLER GROUP LLC.

DODGE 



15WD01-926-AA
DURANGO

SECOND EDITION
USER GUIDE