

CS
ILLUSTRATION
PREVIEW

AUDIO

AUGUST
1972 60c

The Authoritative Magazine About High Fidelity® A

23602

New Trackability Test for Phono Pickups

■ Q's & A's on Phono Cartridges ■

*** A New Phono Stylus ***

How We Test Phono Cartridges

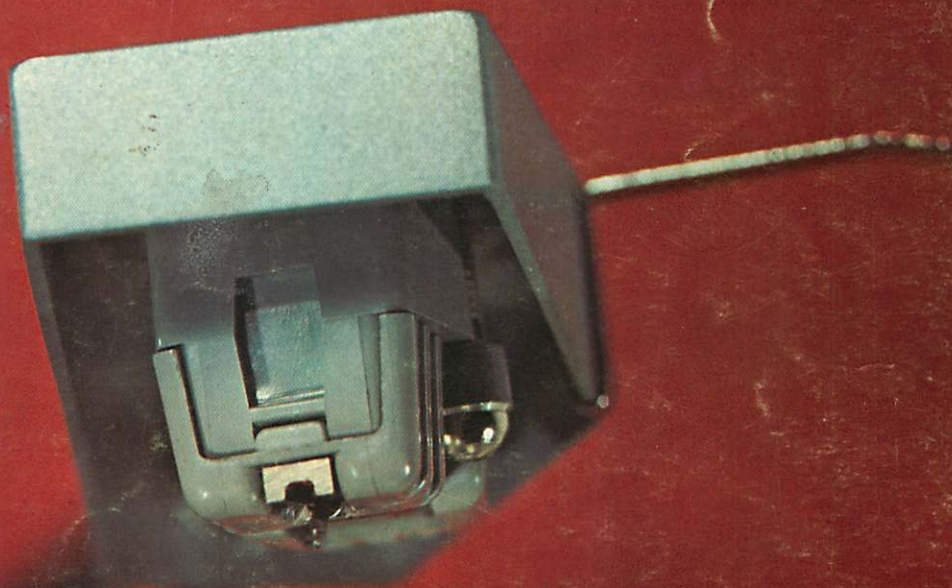

a trio even Bach

Bach wrote far fewer trios than Telemann or Vivaldi (or many other composers for that matter), but the ones he did write are models of excellence. His designs were created within the established musical forms of the age, yet his innovative genius brought to the trio a perfection, a completion not seen before his time, and probably not surpassed since.

In similar fashion, the innovators at H. H. Scott don't produce a trio very often, but when they do, the products bespeak unquestioned excellence. Excellence in form and function. Excellence in engineering and execution. Excellence in those important qualities that stand the tests of time.

The first member of the Scott trio is 357B, an FM-AM stereo receiver with 25 watts per channel for \$214.90. Its predecessor was 357, introduced last year to acclaim from all corners. As recently as June of this year, Stereo Review found the 1972 model 357 the most powerful of 16 two-channel stereo receivers tested in the under \$250 price range. This year it's back, with new styling, and there'll be enough for everyone.

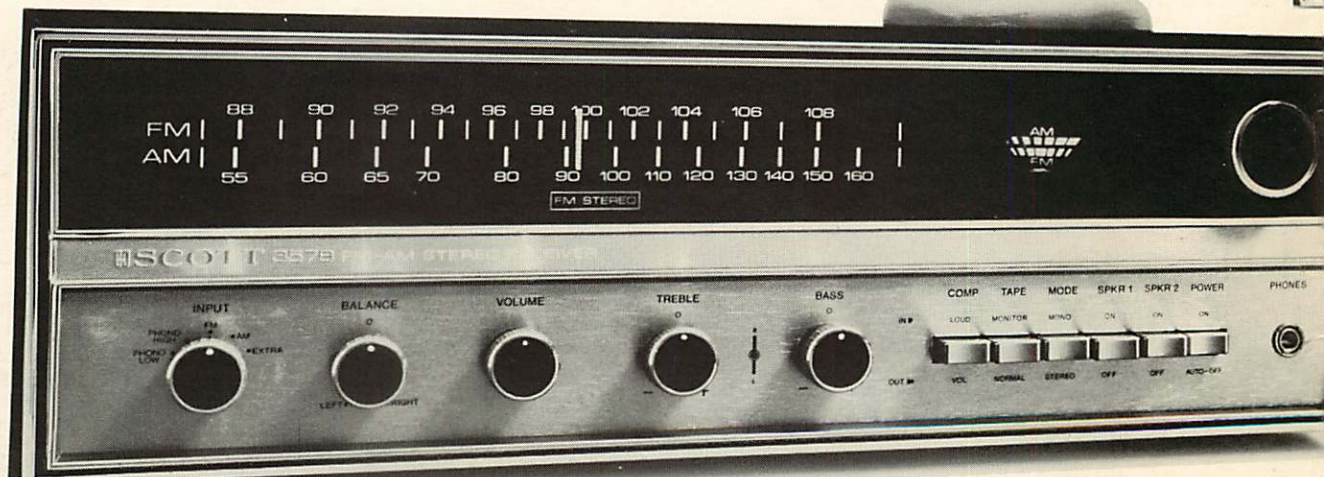

would appreciate

The middle member of the H. H. Scott trio of stereo receivers is the 377B at 40 watts per channel for \$319.90. And the heavyweight is the 387B at 55 watts per channel for \$359.90. It's a modernization of the now famous 387, one of the most widely and favorably reviewed receivers in audio history. Last year, Electronic World said it has "one of the most powerful amplifiers ever offered in an integrated receiver." Now it, too, is back with new styling and a comfortable old price.

The H. H. Scott trio is now on display at your Scott dealer's. Stop in to see and play all three yourself. Even Bach would appreciate this trio. We think you will too!

SCOTT[®]
where innovation is a tradition
H. H. Scott, Inc., 111 Powdermill Road, Maynard, Mass. 01754

Check No. 100 on Reader Service Card

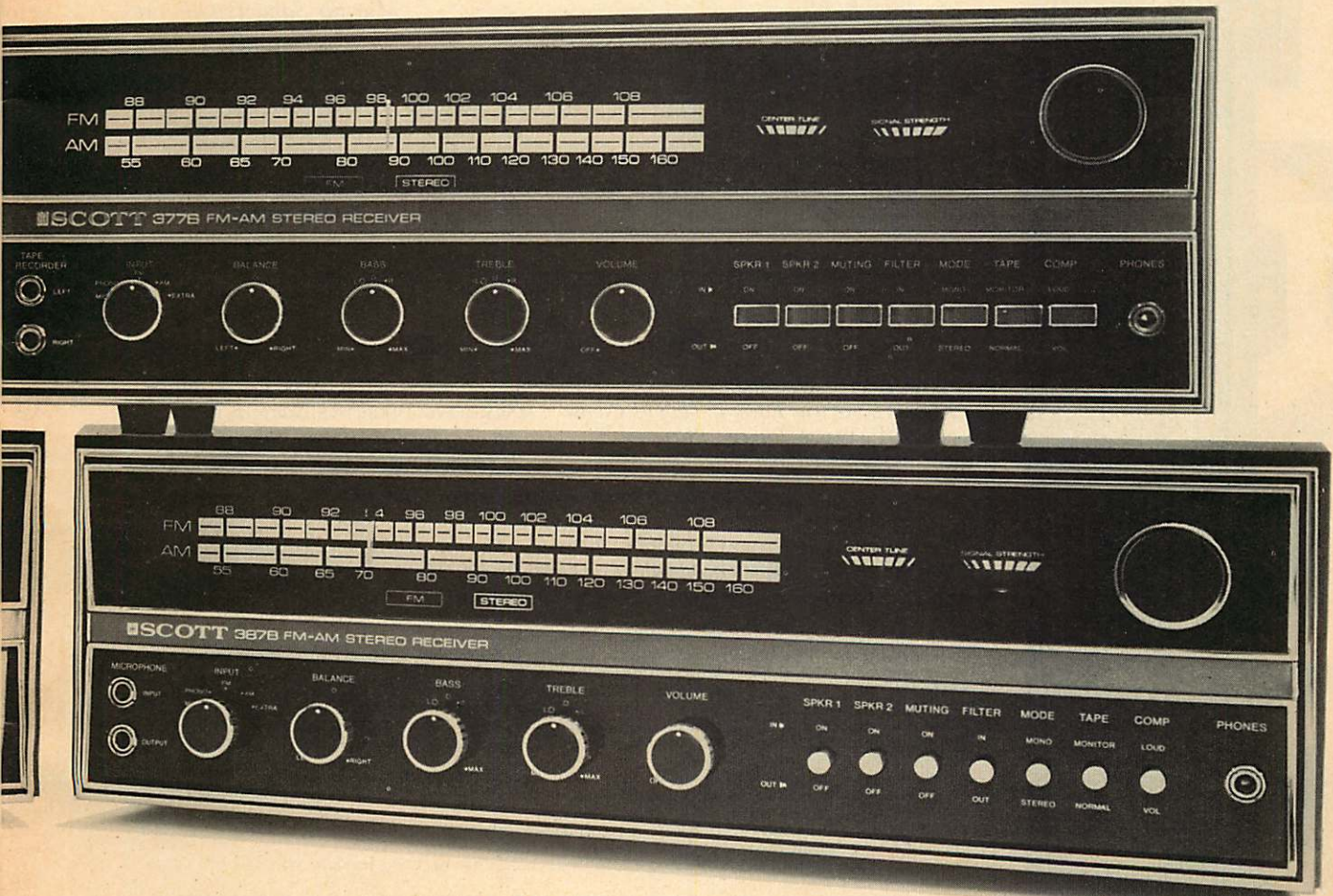

**BEST-BUY
OF-THE-YEAR
BREAKTHROUGH!**

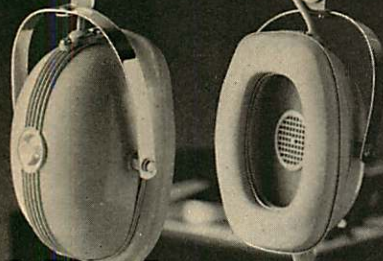

**TOP-RATED
MODEL 10**

First choice of
sound laboratories
and professional
musicians.

"Smoothest
sounding
headphones."
Regularly
fair-traded
at \$39.95.

FIRST TIME!
Now at
SPECIAL
Factory-Authorized
LOW PRICES!

For a limited
time you can
buy these
world-famous
stereo
headphones
featuring
liquid-filled ear
cushions and
coiled cord...
and yet pay
many dollars
less than the
normal list price!

For complete
literature and
list of Sharpe
franchised
dealers, check
the reader
service card.

**SHARPE
AUDIO
DIVISION
SCINTREX INC.**
Tonawanda, N. Y.
14150

Export Agents
**ELPA MARKETING
INDUSTRIES, INC.**
New Hyde Park,
N. Y. 11040

Check No. 12 on Reader Service Card

AUDIO

AUGUST 1972

Successor to **RADIO** Est. 1917

Vol. 56, No. 8

FEATURE ARTICLES

- | | | |
|----|--|--|
| 20 | New at the Consumer Electronics Show | |
| 25 | The Language of High Fidelity, Part III | <i>Martin Clifford</i> |
| 33 | A New Concept in Diamond Styli | <i>Dr. Hedi Benz</i> |
| 34 | A Practical High Frequency Trackability
Test for Phono Pick-Ups | <i>C. Roger Anderson
& Paul W. Jenrick</i> |
| 38 | How Phono Cartridges Are Tested | |
| 40 | Q's and A's on Phono Cartridges | |
| 51 | Audio ETC | <i>Edward Tatnall Canby</i> |

EQUIPMENT PROFILES

- | | | |
|----|--------------------------------------|-----------------------|
| 42 | Sony/Superscope Quadradial tape deck | <i>Model TC-277-4</i> |
| 44 | Pioneer speaker system | <i>Model CS-E400</i> |
| 46 | B&W speaker system | <i>Model 70-CA</i> |
| 48 | Panasonic AM/FM stereo receiver | <i>Model SA-5800</i> |

RECORD REVIEWS

- | | | |
|----|---------------------------|-------------------------------|
| 55 | Classical Record Reviews | <i>Edward Tatnall Canby</i> |
| 60 | Canby's Capsules | <i>Edward Tatnall Canby</i> |
| 61 | Weingarten Looks At . . . | <i>Sherwood L. Weingarten</i> |
| 64 | Jazz & Blues | <i>Martha Sanders Gilmore</i> |

AUDIO IN GENERAL

- | | | | |
|----|--------------------------------------|----|-------------------------------------|
| 4 | Coming In September | 12 | Behind The Scenes <i>Bert Whyte</i> |
| 4 | What's New In Audio | 16 | Tape Competition |
| 6 | Audioclinic <i>Joseph Giovanelli</i> | 18 | Editor's Review |
| 8 | Tape Guide <i>Herman Burstein</i> | 56 | Advertising Index |
| 10 | Dear Editor: | 72 | Classified Advertising |



EDITOR *George W. Tillett*

ASSOCIATE EDITOR *Edward Tatnall Canby*

ASSISTANT EDITOR *Eugene Pitts*

DESIGN *Barbara Long*

PUBLISHER *Jay L. Butler*

MARKETING DIRECTOR *Sanford L. Cahn*

COVER DESIGN *John Kwasizur*

SUBSCRIPTION MANAGER *Jean Davis*

ADVERTISING PRODUCTION *Sharon Mancini*

CONTRIBUTING EDITORS: *Herman Burstein, Martin Clifford, Leonard Feldman, Richard Freed, Joseph Giovanelli, C. G. McProud, Harry E. Maynard, Alexander Rosner, Sherwood L. Weingarten*

AUDIO (title registered U.S. Pat. Off.) is published by North American Publishing Co., Irvin J. Borowsky, President; Frank Nemeyer and Roger Damio, Vice Presidents; R. Kenneth Baxter, Vice President/Production; Nate Rosenblatt, Promotion Director; Mary Claffey, Circulation Director.

RATES—U.S. Possessions, Canada, and Mexico, \$6.00 for one year; \$10.00 for two years; all other countries, \$9.00 per year. Printed in U.S.A. at Columbus, Ohio. All rights reserved. Entire contents copyrighted 1972 by North American Publishing Co. Second class postage paid at Philadelphia, Pa., and additional mailing office. Back issues, \$2.00 each.

REGIONAL SALES OFFICES: Jay L. Butler, Publisher, and Sanford L. Cahn, Marketing Director, 41 East 42nd St., New York, N.Y. 10017, telephone (212) 687-8924.

Jay Martin, 15010 Ventura Blvd., Sherman Oaks, Calif. 91403, telephone (213) 981-7852.

REPRESENTATIVES, United Kingdom: Overseas Newspapers (Agencies) Limited, Cromwell House, Fulwood Place, London W.C.1, telephone 01-242-0661, cables, WESNEWS, London PS4.

Continental Europe: John Ashcraft, 12 Bear St., Leicester Square, London W.C. 2, telephone 930-0525. For Benelux and Germany, W.J.M. Saunders, Mgr., Herengracht 365, Amsterdam, Holland, telephone 24.09.08.

Japan: Japan Printing News Co., Ltd., No. 13, 2 Chome Ginza Higasi, Chuo-ku, Tokyo, telephone 541-5795.

AUDIO Editorial and Publishing Offices, 134 N. 13th St., Philadelphia, Penna. 19107

Postmaster: Send Form 3579 to the above address

HERE IS THE WORLD'S ENTIRE SELECTION OF AUTOMATIC TURNTABLES WITH ZERO TRACKING ERROR.

There they are. All one of them. Garrard's Zero 100, the only automatic turntable with Zero Tracking Error.

Not that there haven't been attempts by other turntable makers. Many have tried. This is the first to succeed. And it has succeeded brilliantly. Expert reviewers say it's the first time they've been able to hear the difference in the performance of a record player...that the Zero 100 actually sounds better.

It's all because of a simple but superbly engineered tone arm. An articulating auxiliary arm, with critically precise pivots, makes a continuous adjustment of the cartridge angle as it moves

from the outside grooves toward the center of the record.

This keeps the stylus at a 90° tangent to the grooves. Consequently tracking error is reduced to virtual zero. (Independent test labs have found the test instruments they use are incapable of measuring the tracking error of the Zero 100.) Theoretical calculations of the Zero 100's tracking error indicate that it is as low as 1/160 that of conventional tone arms.

Zero tracking error may be the most dramatic aspect of Zero 100, but it has other features of genuine value and significance. Variable speed control; illuminated strobe; magnetic anti-skating;

viscous-damped cueing; 15° vertical tracking adjustment; the patented Garrard Synchro-Lab synchronous motor; and exclusive two-point record support in automatic play.

The reviewers have done exhaustive reports on Zero 100. We believe they are worth reading, so we'd be happy to send them to you along with a 12-page brochure on the Zero 100. Write to us at: British Industries Co., Dept. H12 Westbury, N.Y. 11590.

**GARRARD
ZERO 100**

\$199⁹⁵

less base and cartridge



Coming in September

•Annual Directory of Stereo Hi-Fi Component Equipment—

Here in one issue is a comprehensive directory of what's available: Amplifiers Receivers Turntables and Record Changers Phono Cartridges Tape Recorders—Reel-to-reel, 8-track, and Cassette Headphones Loudspeaker Systems.

•Articles Include

Making A Nine-Octave Equalizer

The Language of Hi-Fi,

Part 4 of Martin Clifford's guide for beginners

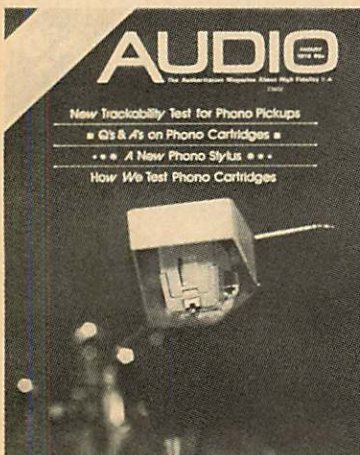

About the Cover: This photo shows a groove's eye view of phonograph cartridge—something an audiophile seldom sees except when inspecting his stylus. Pick-ups of the future probably won't look much like this and may well follow the path shown by the Teldec video disc, which has a 70 kHz bandwidth at 33½ rpm.

What's New in Audio

Marantz SD-1 headphones

These headphones have a specified frequency response of 20 to 20,000 Hz and utilize metalized mylar diaphragms. The ear pieces are covered with padded leather-like vinyl for comfortable seating, isolation from external noise, and extended bass response. Nominal impedance is 8 ohms. The unit comes equipped with a 10-ft. coiled cord and standard phone plug. Price: \$29.95.

Check No. 101 on Reader Service Card



Design Acoustics D-12 speaker

This three-way system incorporates 11 drivers of three different sizes—9 tweeters, a 5-in. midrange, and a 10-in. woofer. Crossover frequencies are 750 and 1500 Hz, and Helmholtz resonance is 27 Hz. Reverberant field pressure is said to be uniform from 25 to 15,000 Hz, and room placement is non-critical. Price: \$325.00.

Check No. 102 on Reader Service Card

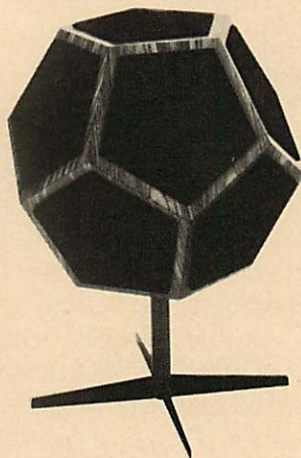

Pioneer SA-600 stereo amplifier

This stereo amp can deliver 26 watts continuous power across 8 ohms with less than 0.5% harmonic or IM distortion. Frequency response is 15 to 70,000 Hz ± 1 dB. Facilities include two pairs of tape monitors, phono and AUX input terminals, high and low filters, bass and treble controls, balance selector, loudness control, etc. Price: \$179.95.

Check No. 103 on Reader Service Card

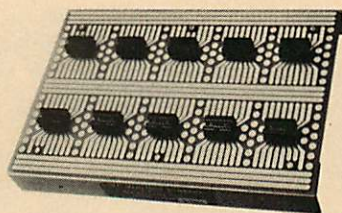

Prototype Circuit Boards

The Maratron Co., now has a new line of boards available which are specifically suitable for transistor and IC applications. Model 131 is for 4-lead transistors, Model 141, shown, is for 16-lead DIP's, and others include boards for 8-lead TO-5 IC's and dot patterns. Price: \$9.95 per board (less sockets).

Check No. 104 on Reader Service Card



Sanyo DCA1700X decoder-amp

This unit converts any standard two-channel amplifier or receiver for four-channel use; all that's needed in addition is a second pair of speakers. Power output is 40 watts rms at 8 ohms, 0.8% THD. Frequency response is specified at 10 to 100,000 Hz ± 2 dB, while bandwidth is 15 to 100,000 Hz ± 1 dB. There are inputs for four-channel tape, two phono, and two AUX.

Check No. 105 on Reader Service Card

Your next receiver should have 3 things missing.

The input transformer. The output transformer. And the output capacitor. Because when you cut those three things out of a receiver, you cut down on a fourth thing. Distortion. We do it with a system called direct coupling. And Panasonic puts it in all its FM/AM/FM Stereo Receivers.

With this system the amplifier circuit is coupled directly to the speaker terminals. To improve transient response and damping. So there's less than 0.8% harmonic distortion. To help you hear only the sound of music.

The sound of the SA-6500 is really something to listen to. With a full 200 watts of power (THF). To fill even a big room with music. And there's also a power band

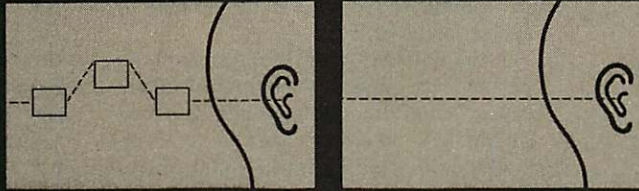

width of 5 to 60,000 Hz.

The SA-6500 also has two 4-pole MOS FET's. That provide $1.8\mu\text{V}$ FM sensitivity. To pull in FM stations that are too weak or too far to make it on their own. Integrated circuitry and a crystal filter improve the capture ratio. And there are low-filter, high-filter, and loudness switches. So the music comes out closer to the way it started out. And an FM linear dial scale and two tuning meters. To make the music you want just a little easier to find.

You can also find that music on the SA-6200. With 150 watts of

power. Plus 2 RF stages and 6 IF stages. To provide selective station tuning. And there are PNP low-noise silicon transistors in the differential amplifier drive-stage. To give almost noise-free performance. No matter who's performing.

For less money you can still get a lot of power. From our SA-5800. With a full 100 watts. The SA-5500. With 70 watts. Or our newest receiver, the SA-5200. With 46 watts. And features you'll find in our more expensive units.

So before you get your next receiver, see your franchised Panasonic Hi-Fi dealer. He'll show you what should be missing. So you don't miss out on anything.

Panasonic® Hi-Fi 2-Channel Receivers



200 Park Ave., N.Y. 10017. For your nearest franchised Panasonic Hi-Fi dealer, call toll free 800 243-6000. In Conn., 1 800 882-6500.

Check No. 5 on Reader Service Card

Improving AM Reception

Q. Since New York's only C and W station recently went off the air, I have had to take to AM dx'ing—both to pull in skip stations and low-power suburban stations.

Most of the AM radios and receiver sections that I have seen, however, seem to be mediocre at best. I have decided, therefore, that the most logical solution would be to purchase a good car radio and use it in my apartment. They appear to be designed to work under difficult conditions with superior sensitivity, shielding, etc. What is more, the whip antenna can easily be mounted on my windowsill or even outside the window.

The question that I want to ask you is what to do about a power supply. I have seen so-called "battery eliminators" on the market which convert house voltage to 12V.d.c. However, will it be necessary for such a unit to match the internal resistance—or perhaps some other parameter—of a car battery? If so, will there be any way that I can modify the circuitry to achieve this?—Edward Subitzky, New York, N.Y.

A. Car radios are really little better than any other type of AM set. They generally have better AVC systems because they are often called upon to operate adjacent to broadcast transmitters. They do have an RF stage which does give them a measure of sensitivity. Because of your location and because the likelihood that you will be surrounded by TV sets which radiate a tremendous amount of interference, I am not sure that the use of a car radio will solve your problem.

If you want to experiment with a car radio, the power supply problem is not a serious one. The standard battery eliminator will be fine for your purpose. Their internal resistance is low enough so as not to be troublesome.

I suggest that you obtain a communication receiver. Such a receiver, in addition to having shortwave bands, has good i.f. selectivity. This selectivity will eliminate some "hash" caused by the TV sets in your neighborhood and will also eliminate most of the 10 KHz whistles which will be heard at night. Good communication receivers also have "notch" filters which help to eliminate some of the TV "birdies." Although the fidelity of sound reproduction will suffer when heard over such a receiver, at least it

does offer you the best chance of hearing distant signals without annoying background noise. (Highs are lost because of the sideband cutting created by the selectivity of the IF system in such a receiver.)

I do not say that reception will be perfect, but stands a chance of being much better than that which you can obtain with any other kind of receiver.

Generally, the audio in communication receivers is as bad as that in TV sets. Therefore, it would be best to take the signal from the detector, rather than from the audio output of the receiver.

A few feet of antenna wire connected to the back of the receiver is probably all you will ever need. (Of course, if you are in a steel building, it might be well for this wire to hang out the window. As was true of your possible car radio installation, you can mount a whip outside the window, thereby making a sturdier installation.) You know that a long antenna is often used with communication receivers. Although such an antenna has its advantages, you do not necessarily have to have one. Man-made noise imposes limits of reception which often will make the added antenna length useless.

Although this was not your original purpose, you may find that shortwave listening—made possible because of your communication receiver—can be fun and can open up a new world of entertainment.

It should be noted, too, that some of the newer, top-of-the-line receivers are including AM sections which very nearly match their FM counterparts in quality of output.

Four-Channel Sound

Q. Some of the new four-channel receivers advertisements speak of four-channel sound effect from two-channel sources with the addition of two more speakers. Does this include a two-channel or four-channel tape deck?—Sp/4 James C. Gunter, APO San Francisco, Cal.

A. There are receivers featuring four separate power amplifier sections. Recognizing that at present there is not much true four-channel sound available, equipment is often included to enhance two-channel listening so as to make use of all four power amplifier sections. The en-

hancement is brought about by the judicious use of some form of matrixing and/or reverb.

When this enhancing circuitry is not included in the receiver, it is available separately from manufacturers such as CBS, Electro-Voice, and Sansui. A straight four-channel amplifier or receiver can readily be converted to play encoded discs or tapes merely by the addition of these add-on devices. The tapes or discs are especially processed masters which are actually two-channel. The phase relationships, however, are such that four-channel output appears from the decoder. Although there are these especially encoded records which make maximum use of these decoders, conventionally recorded two-channel discs will often produce excellent four-channel spatial effects when played these decoders.

There is also the Dynaco decoder which uses four speakers but with just two power amplifier sections as in conventional stereo. It is the interconnection of the speakers to the amplifier which is non-standard and produces the four-channel effect.

While it is possible to obtain four-channel tape decks which can feed into the four separate amplifiers of a receiver/integrated amplifier, it is also possible, because of the synthetic or combining systems just described, to obtain good four-channel results from two-channel tapes or discs.

European Equalization

Q. I often purchase imported phonograph records, mainly from Germany and England. These discs would have the European equalization. My amplifier has RIAA equalization. Am I losing quality when playing back these discs? If so, is there any way to correct the situation?—Louis Hone, Montreal, Canada

A. As far as I know, European discs are equalized just as ours are. Therefore, you should not encounter any problems in this regard when playing them.

If you have a problem or question on audio, write to Mr. Joseph Giovanelli at AUDIO, 134 North Thirteenth Street, Philadelphia, Pa. 19107. All letters are answered. Please enclose a stamped self-addressed envelope.

Progress in noise reduction: 1972

Listeners, reviewers, dealers, and manufacturers together have established Dolby™ noise reduction circuitry as the industry standard.

1 A few years ago tape noise seemed an insoluble problem; now, millions are enjoying low-noise Dolby tapes and broadcasts. In June of this year, at the giant international Consumer Electronics Show in Chicago, 27 *brand new* products with Dolby circuits were announced and on display, in addition to the many already available. The list of Dolby hardware manufacturers now includes:

Advent	Matsushita (National-
AGS	Panasonic)
Aiwa	Mitsubishi
Akai	Nakamichi Research
Allied Radio Shack	Nippon Columbia
Bell & Howell	Nippon Gakki (Yamaha)
Benjamin	Otari
Bigston	Pioneer
Concord	Planet Research
Crown Radio	Rank Wharfedale
Ferrograph	Revox
Fisher	Sansui
General	Sanyo
Harman-Kardon	Sharp
Heath	Shin-Shirasuna (Silver)
Hitachi	Sonab
JVC (Nivico)	Sony
KLH/Singer	Standard Radio
Kellar	Tandberg
Kenwood/Trio	Teac
Lafayette	Teleton
Lenco	Tokyo Shibaura (Toshiba)
	Wollensak/3M

2 More and more Dolbyized™ cassettes are available every month, and can be bought wherever cassettes are sold. Because they will not become obsolete, Dolbyized cassettes guarantee that you get the best sound now – and later. Soon, Dolbyized 8-track cartridges will be available, bringing low-cost, effective noise reduction to both stereo and 4-channel cartridge formats.

3 Dolby FM broadcasts are now a reality. Millions of New York area listeners can hear full-time Dolbyized programs broadcast by WQXR, one of the nation's leading classical music stations. When the received signal is fed through a Dolby unit, interference and background hiss, including noise generated in the FM tuner itself, are all greatly reduced.

4 The best of open-reel tape recorders are now available with Dolby B processors built into them. Recordings made in homes, schools or on location now can virtually match the quality of professional studio tapes.

'Dolby', 'Dolbyized' and the double-D symbol are trade marks of Dolby Laboratories Inc



Dolby Laboratories Inc
1133 Avenue of the Americas, NY 10036
Telex 125797

346 Clapham Road, London SW9
Telex 919109

Tiger Building 30-7 4-chome Kuramae
Taito-ku, Tokyo
Telex J22498

Input Matching

Q. I have a transistor tape deck with a microphone input impedance of 3,000 ohms, and the manual says a microphone with impedance between 2,500 and 5,000 ohms should be used. However, I have not been able to find a mike with impedance in this range. If I use a low impedance microphone with a stepup transformer, can I expect as good quality as if I had a low impedance input in my tape recorder?—Grant C. Downey, Sheppard AFB, Texas.

A. You do have a problem, inasmuch as low impedance mikes are typically in the range of 50 to 600 ohms, while high-impedance ones are typically in the range of 10,000 to 25,000 ohms. Therefore it appears that you will have to use a low-impedance mike with a stepup transformer. Moderately priced microphones of good quality and low impedance are available, and a suitable stepup transformer of good quality will not impair its performance.

Visual Volume Level

Q. I have a six-foot stack of LP's which I plan to put on tape. I feel I need a piece of equipment that optically registers the volume level. Could you recommend such a piece of equipment?—Edmund L. Vincent, Warwick, R.I.

A. The record-level indicator of your tape recorder should do the job, that is, enable you to compensate for different volume levels of different records.

Reducing Hiss

Q. I am primarily concerned with recording live music on my Ampex PR-10 tape machine. I am experiencing a slight hissing noise in the background of my tapes. I have tried different types of recording tape and have settled for Scotch 201. I have aligned the bias for this tape and keep the heads demagnetized. The recorder is a stereo model, and both channels exhibit the noise. I am almost sure the noise originates in the preamps, as I can turn the power amplifier up in the idle state and hear what sounds like "shot" noise in transistors. Although the noise is not a serious problem, I would like to do all I can to eliminate it as I hope to use my Ampex for master tape recording. I estimate my S/N ratio to be about 52 to 55 db, and I would like to improve this to about 58 to 60 db. Could I change the 12AX7 tubes in the

preamps to ECC83, 12AY7, or 7025 types? How about changing the resistors in the preamps to low-noise types? I have tried using Scotch 120 (high output) tape, but noticed a slight loss of high frequencies, although the increased S/N sounds great.—William O. Stottlmyer, Trezevant, Tenn.

A. It is not clear from your query whether the hiss originates predominantly in recording or playback. Sometimes hiss in recording is due to excessive attenuation of the incoming signal (to avoid overloading the first amplification stage). In any case, I am sort of doubtful that changing the 12AX7 for an equivalent type of tube will produce significant improvement. One might suspect an individual tube to depart from the average for its type in terms of noise, but this seems not to be your problem inasmuch as you have the same hiss on both channels. However, I only doubt; I am not sure; changing to an ECC83 or 7025 might yield a tiny improvement. Better yet, if possible, you might try using selected tubes of one of the types you have mentioned; this means having a handful of tubes from which to choose. I am more inclined to think that using high quality low-noise resistors will produce desired results. Deposited metal-film resistors are worth trying. Use these both in the plate and cathode circuits of the first stage. Sometimes the use of low-noise resistors in the second stage may also improve matters.

Balanced and Unbalanced Lines

Q. I would like to know the principal of balanced lines as used with mikes. To what should the second wire be connected if not to ground?—Harvey W. Kunz, Old Tappan, N.J.

A. In balanced line circuits, the microphone feeds the primary winding of a transformer. Neither end of this winding is grounded. You can see that if the two leads from the microphone are connected to such a transformer, the signal will still see a complete path even though the primary is not grounded. This causes a voltage to be developed across this winding when the mike is driven. This voltage is then induced into the transformer's secondary winding and the signal is on its way to the audio circuits.

What I have described is the typical balanced line circuit. It will produce less hum than the conventional unbalanced system. This is reasonable

when you consider that any hum voltage which is induced into the cable will be induced into both conductors.

The direction of the induced hum voltage will be the same for both conductors. In order that a signal can appear across the primary of the input transformer, there must be a difference in polarity between the two hum voltages, just as is produced by the microphone. Thus, while hum voltage is present, it is not heard to any extent because it is cancelled out.

The chances are that is no other precautions are taken, some hum will be present. The cable is, therefore, shielded, with one end of the shield connected to the microphone case. The other end is grounded to the mike preamplifier. The shield does not carry signal. It acts to minimize the amount of hum voltage induced into the cable.

The unbalanced line has only one conductor. Any hum able to penetrate the shield will not be cancelled in the manner of the balanced line system. The hum will appear as such in the output of the recorder, public address system or what have you.

The unbalanced line is what you are likely to be most familiar with; it is used to interconnect program sources in high fidelity music systems. The shield actually carries the signal.

Mono on Four-Track Machines

Q. I have several hundred 78 rpm records and would like to record them on tape. Would I be able to record four single tracks on a stereo tape machine? Would you advise the 3/4 ips speed or 7/8 ips?—William C. Day, Springfield, Ohio

A. Most quarter-track stereo tape machines permit you to record four mono tracks. With a reasonably good quality tape recorder, the 3/4 ips speed should be adequate for the purpose you have in mind. In fact, the reduced treble response at 3/4 ips compared with 7/8 ips may be advantageous in cutting noise.

If you have a problem or question on tape recording, write to Mr. Herman Burstein at AUDIO, 134 North Thirteenth Street, Philadelphia, Pa. 19107. All letters are answered. Please enclose a stamped, self-addressed envelope.

Pioneer's new SE-L40 stereo headphones flabbergasted the experts.

High fidelity dealers are probably the most blasé guys in the world. They've seen everything. They've heard everything. You really have to have something extraordinary to impress them. So when we introduced the new Pioneer SE-L40 stereo headphones at a recent home entertainment electronics show for dealers, we were overwhelmed at its enthusiastic reception. We expected applause. We received an ovation.

These super critics marveled at the new open-air design which enhances the intimacy of personalized listening. They enthused over the incomparable bass reproduction achieved by a combination of technological advances and newly developed speakers nestled into each earpiece. They lauded the extreme light weight, nearly one third less than present headphones. Their conclusion: the SE-L40 is a complete departure from conventionality.

If you're still skeptical and believe that Pioneer high fidelity dealers went overboard with their acclaim for SE-L40, there's only one way you're going to be convinced.

Visit a Pioneer dealer and listen.

SE-L40 stereo headphones, \$39.95, with carrying case. Other

quality Pioneer headphones
from \$24.95.

U.S. Pioneer Electronics Corp.
178 Commerce Road, Carlstadt
New Jersey 07072

 **PIONEER**[®]
when you want something better



Can the EVX-4 4-Channel Decoder face up to records encoded for Columbia SQ, Sansui, Dyna, and all the rest?

Yes. Listen. Play "their" best demonstration records through the EVX-4 or the E-V 1244X add-on decoder/stereo amplifier.

In most cases you'll hear little or no difference. Some records may even sound better to you through our decoder than through theirs! How can this be? Because you're listening to music... not ping-pong or algebra. And our decoding is basic.

STEREO-4™ decoders can do the best job at the lowest cost for all 4-channel matrix records and FM broadcasts. Not to mention how well they enhance your present stereo records, tapes, and FM.

But don't take our word for it. Listen carefully. Make your own discovery that "their" records can make the best case for "our" decoders!



EVX-4
Stereo Decoder
\$59.95 suggested
resale



E-V 1244X
Decoder/Stereo Amplifier
\$149.95 suggested resale

a **Gulton**
COMPANY

ELECTRO-VOICE, INC., Dept. 824A
602 Cecil Street, Buchanan, Michigan 49107
In Europe: Electro-Voice, S. A., Römerstrasse 49, 2560 Nidau, Switzerland
In Canada: EV of Canada, Ltd., Gananoque, Ontario

Electro-Voice®

Check No. 10 on Reader Service Card

Dear Editor



Humpty Dumpty?!?

Dear Sir:

Last fall I subscribed to *Humpty Dumpty* magazine for my six-year-old son, Jeffery. Somehow we ended up receiving *AUDIO*—which, of course, is way beyond his head. We have no interest in receiving your magazine.

Therefore, please cancel this subscription immediately and refund the cost.

Mrs. Charles Ziegler
Pompton Plains, N.J.

We appreciate the fact that AUDIO is beyond your son's abilities at present and have accordingly cancelled his subscription. A refund of the subscription

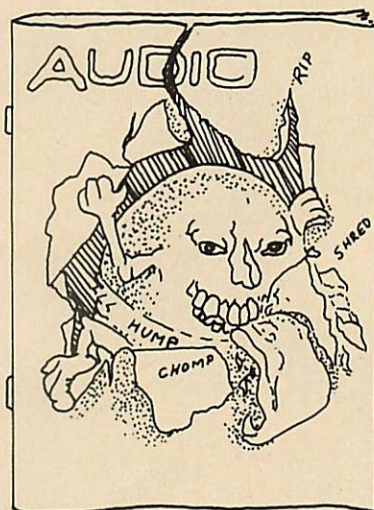

cost is a bit difficult since orders which come in through agencies, as yours did, are accompanied by only a small portion of the subscription cost. At this point, all we can do is refer you back to the subscription agency, though we think you'll have no problem with them.—Ed.

Classical Music, Bah!

Dear Sir:

I am a technician; I am also a former professional musician (bass fiddle). I am semi-well educated (still going to college), read a great deal, can't spell worth a darn, have two kids, like Satie, don't like Wagner, know something about hi fi (I sell it too), and don't like being written down at.

Yes, being written down at. All the monthlies seem to have one great bag in their editorial policies, yourselves included, and that is **CLASSICAL, CLASSICAL, CLASSICAL**.

this, classical that, classical the other. Phooey. I like good music as much as the next guy, but too much is just that, too damn much. Classical buyers comprise some six per cent (?) of the buying public, yet the magazines cater to that particular six per cent in over 95 per cent of their editorial content and, seemingly, policy.

Well, I kind of like Blood, Sweat, and Tears, Buddy Rich, Cannonball Adderly, Simon and Garfunkle, and others in with my von Karajan, Ormandy, and Bernstein (just my rather pedestrian taste, though). I hear little of those and much of unheard and sometimes unhearable classical recordings.

I admit it, I am not a musical snob. I can't stand only one segment of the recorded material available (acid rock) and am open to all comers when the word music comes up. But how about you, you and the other editors of the other magazines, aren't you just a little bit snobby about your choices of music? Don't you peddle just a little heavily on the snob appeal of the classical and just a lot lightly on the unsnob appeal of the not-classical? I wonder.

Thomas N. Ronayne
Detroit, Mich.

I cannot speak for the editors of other magazines, but I must say my own musical tastes are very wide though I certainly would not rate classical music in terms of sales. I believe that Beethoven, for instance, will continue to inspire people long after much of today's music is forgotten. This does not mean that I cannot enjoy jazz and other kinds of music—for from it. As to snobbery, I thought the definition of a musical snob is one who enjoys (or pretends to enjoy) John Cage, electronic mayhem, or pornographic anti-establishment dirges.—Ed.

Now You Hear It; Now . . .

Dear Sir:

I have followed with interest the proposed use of the Dolby "B" system for FM broadcasts. One thing bothers me, however, and I hope you can help me and your other readers by providing an answer in a future issue. What method will be used to cause the FM receiver to automatically switch the Dolby equalizer into or out of the circuit? Surely, it won't be a manual function, as the early stereo was. That would never do.

John R. Truitt
LaGrange, Ill.

Listen



to the irresistible sound of Martin Speakers

The sound of Martin Speakers can be as quiet and irresistible as the gentle meeting of sand and surf. Or vibrant and deepthroated as the roar of thunder in the summer sky.

Martin Speakers, for people who are attuned to the irresistible sounds of the audible universe.



MARTIN SPEAKER SYSTEMS • A DIVISION OF EASTMAN SOUND MANUFACTURING CO., INC.

Harmony Road and Route 295
Mickleton, New Jersey
08056

Martin Speakers from \$44.50 to \$350.00

"A new standard of performance built
by people who listen."

Check No. 11 on Reader Service Card

Behind The Scenes

Bert Whyte

EVERY YEAR come June, it is time for the Consumer Electronics Show in Chicago. The arrival of this show is always greeted with mixed feelings. It is nice to see many old friends in the industry, and while all the shiny new equipment has its undeniable allure, the thought of what one has to endure to see this equipment, gives pause. Last year the show merely occupied the main floor of McCormick Place. This year, the CES management has proudly announced that the entire lower floor has been used for exhibitions as well. Well, friends, that adds up to . . . hold your breath . . . an area equivalent to 20 football fields! I can tell you that this rotund reporter isn't going to take in every exhibit . . . not unless they furnish me with a golf cart. Oh, well . . . a lot of the stuff isn't in my purview, and some of the more exotic hi-fi stuff is always demonstrated in the undeniably better acoustic conditions in the local hotels. McIntosh, Bose, Crown, and Harman-Kardon are among those which will hold forth in the hotels.

If the CES last year was slanted towards quadraphonic sound and Dolby noise reduction, it is the same this year, *in spades!* Everybody but everybody is showing quadraphonic receivers, amplifiers, pre-amps, open reel decks. Dolby cassette decks are legion. The astonishing aspect of all the quadraphonic equipment is the great numbers of units which incorporate the SQ decoder circuitry. Astonishing, because SQ is not industry standard, nor is any other matrix system, and especially so in view of an apparently very viable RCA/JVC discrete disc. The proliferation of the SQ equipment must be viewed as a great compliment to the power of Columbia software. They have the name artists, they have released or announced more quad recordings than any competing system, and as a result the list of Columbia/Sony SQ licensees grows ever longer. Amidst this sea of SQ quadraphonic equipment at the CES are the RCA, JVC, and Panasonic islands, strongholds of the discrete disc. In the light of recent developments of the discrete disc and demonstrations I have attended, it seems obvious that far from us getting an industry-standard four-channel disc, the battle lines have been drawn anew, each side has called up their reserves, and the issue is still very much in doubt. Apart from the two main contenders, there is a very significant

new development in decoding techniques from Sansui, about which I'll tell you a bit later on. Since the CES pretty well sets the hi-fi merchandising plans for the year, it would seem that at the very least, the matrixing and discrete forces will co-exist. Quite apart from technical considerations, and with all due respect to colleagues Len Feldman and Ed Canby for their expositions of the reasons for and methods of combining the discrete and SQ systems onto one disc, I don't think the two industry giants are going to give an inch to the other side on this point. Somehow, the big boys never learn from experience. Years ago, when the RCA 45 rpm "doughnut disc" was fighting the Columbia 33 $\frac{1}{3}$ LP, it should have been obvious that the 45 was ideal for the pop single market, and the LP for the album and classical market. But no . . . and it is my understanding that in the 18-month "war," the outcome cost RCA some 8 million bucks!

I mentioned earlier some developments on the discrete disc. I attended the Midwest Acoustic Conference in Chicago in April, which this year was devoted entirely to quadraphonic sound. There were some interesting talks by the great tape recording pioneer, Marvin Camras, and by John Volkman, both concerning quadraphonic sound fields and their perception. John Eargle outlined his quadraphonic processing techniques, while Bill Putnam talked about studio quadraphonic recording techniques and the Cooper Time Cube delay unit I reviewed last month. There were other relevant talks on various aspects of quadraphonics and finally there were the discussions and demonstrations from the matrix disc proponents and from the RCA discrete camp. Well, it all started off in gentlemanly fashion, but at the conclusion of the conference, when both sides were answering questions from the floor, there were some indignantly raised eyebrows, then some raised blood pressures, and things got a bit warm! Without taking any sides or casting any aspersions on anyone, in my opinion what started to stir up things was a very dramatic slide presentation and sound demonstration on the discrete disc by RCA. What some factions had undoubtedly felt were very difficult, if not insurmountable problems with the discrete disc, had apparently been resolved. We were shown scanning electron microscope photos of the grooves of a discrete

disc at tremendous magnifications. One such picture was the equivalent of looking at the grooves of a disc *seven miles in diameter!* On the grooves of the disc you could see the tiny peaks and valleys of the supersonic signal. We were shown photos of discs that had been played as much as 200 times with a conical stylus at 5 grams tracking force. There was easily visible evidence that a large proportion of the supersonic signal was worn away. Then the disc was played with a JVC magnetic cartridge and through a demodulator and into four amplifiers and speakers. Sure the disc was noisy, with high hiss and plenty of ticks and pops . . . *BUT* nonetheless we still heard four discrete channels of sound! How come? Well, the RCA/JVC boys had come up with a new type of demodulator, employing phase-lock loop circuitry, just the same as is appearing on the fancy new breed of FM tuners now reaching the market. With this very sensitive type of demodulator, the supersonic signal on a discrete disc can be down as much as 18 dB and can still be picked up and activate the circuit. In addition to the new demodulator, a special record compound with a new type of lubricant incorporated in it was developed. The compound itself is harder than the standard vinyl record. In combination with the new type demodulator, it would appear that this has solved the wear problem that many feared would erase the carrier signal on the discrete disc after relatively few plays. Needless to say, although other problems remained to be resolved with the discrete disc, this dramatic break-through on the wear problem caused considerable consternation in the matrix camp.

Jerry Orbach of JVC was kind enough to furnish me with a CD-4 magnetic cartridge with the new Shibata stylus (a somewhat chisel-shaped affair that purportedly tracks more accurately than an elliptical stylus), a demodulator, and some discrete discs. Incorporating this into my system was a simple operation, and I have been playing discrete discs now for some time. My reaction is generally favorable. The four-channel stereo is excellent, with rock-solid localization of instruments. The normal parameters of frequency response, distortion, and dynamic range were reasonably well preserved. I hedge a little here, because I feel that low frequency response is off a little, due probably to the 11.33 rpm cutting speed

if you go for four channel...

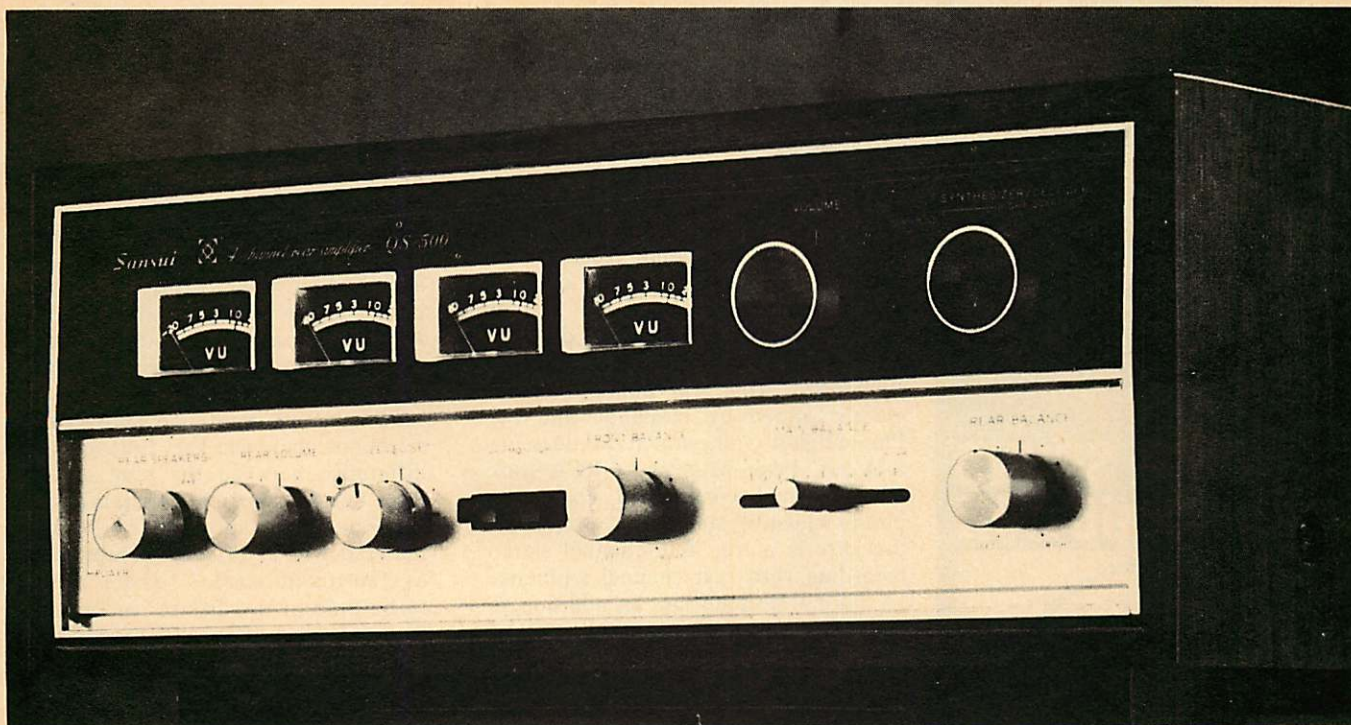

you don't have to go for broke

Buy yourself a miracle for as little as \$214.95 That's all it takes to get your conventional two-channel stereo to do anything any total four-channel receiver and control center can do, now or in the future.

The Sansui QS500 and QS100 converters are complete Four-Channel Synthesizer-Decoder-Rear-Amplifier-and-Control-Center combinations that transform standard two-channel stereo totally. The only other equipment you need is another pair of speakers.

You can decode any compatibly matrixed four-channel broadcasts or recordings and reproduce them in four authentic channels. You can detect the ambient signals present in most two-channel recordings or broadcasts and propagate them through the rear channels. In Sansui matrixing, the exclusive phase-shift technique prevents the cancellation of some signals and the change in location of others that occur in many matrixing systems. And the exclusive phase modulators restore the effect of the live sound field.

You can plug in a four-channel reel-to-reel or cartridge deck or any other discrete source. In the future — if you should have to — you can add any adaptor, decoder or what-have-you for any four-channel system for disc or broadcast that anyone's even hinted at. And a full complement of streamlined controls lets you select any function or make any adjustment quickly and positively.

The QS500 features three balance controls for front-rear and left-right, separate positions for decoding and synthesizing, two-channel and four-channel tape monitors, electrical rotation of speaker output, alternate-pair speaker selection, and four VU meters. Total IHF power for the rear speakers is 120 watts (continuous power per channel is 40 watts at 4 ohms, 33 watts at 8 ohms), with TH or IM distortion below 0.5% over a power bandwidth of 20 to 40,000 Hz. In its own walnut cabinet, the QS500 sells for \$289.95

An alternate four-channel miracle-maker is the modest but well-endowed QS100, with total IHF music power of 50 watts (continuous power per channel of 18 watts at 4 ohms and 15 watts at 8 ohms). In a walnut cabinet, it sells for \$214.95

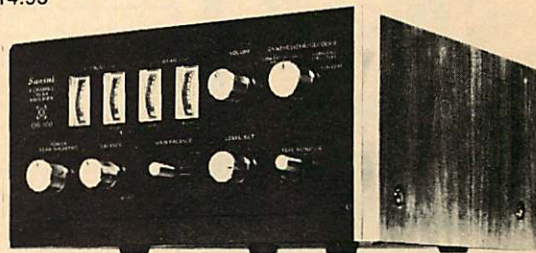

SANSUI ELECTRONICS CORP.

Woodside, New York 11377 • Gardena, California 90247
ELECTRONIC DISTRIBUTORS (Canada), Vancouver 9, B.C.
SANSUI ELECTRIC CO., LTD., Tokyo, Japan • Sansui Audio Europe S. A., Antwerp, Belgium
Check No. 13 on Reader Service Card

UNEQUALLED PERFORMANCE



K-180 Unique design provides "subjectively controllable sound." Innovative **AKG** engineering again provides optimum listening performance... superb sound as you like it!

IN SOUND REPRODUCTION



K-150 Lightweight. Interchangeable cushions affords "fatigue-free" use. Highest performance in true sound. A quality buy!

—AN AKG TRADITION



K-100 Combines **AKG's** traditional high quality sound and wearing comfort. Economically priced!

Try them at your dealer's, or write for more information today!



MICROPHONES • HEADPHONES

DISTRIBUTED BY
NORTH AMERICAN PHILIPS CORPORATION
100 EAST 42ND STREET, NEW YORK, NEW YORK 10017

which is presently necessary to cut the high frequency carrier onto the lacquer. One of the records I received contained excerpts from *Hair*. It so happens that I also have the discrete four-channel stereo cartridge of *Hair*. While the excerpts are slightly different, it was easy to make a comparison, and the disc certainly is as discrete as the cartridge. In fact the disc is to be preferred to the cartridge, because it is much quieter. I must say that someone had better look into Dolbyizing the Quad-8 cartridges. In the home listening experience, the noise is just too distracting. Later on I received the first of the RCA discrete classical discs, a melange of such items as the *Sorcerer's Apprentice*, *Night On Bald Mountain*, etc performed by Ormandy and the Philadelphia Orchestra. It would seem that Mr. Peter Munves of RCA took heed when I complained about the phony classical stereo for, praise be, this disc is a true four-channel stereo recording with rear channel ambience... and well done too! In addition to the as-yet-unresolved problem of broadcasting a discrete disc, the other alleged shortcomings of the JVC disc are said to be a reduction of level and the amount of time that can be cut on a side. The reduction in level would appear to be valid, although variable. On the pop discs I have, the levels seem to be down 2 or 3 dB in comparison to a standard RCA stereo recording. However, on the Ormandy classical disc, the level was down by as much as 5 or 6 dB. Bass response was also down, and the fundamental of the bass drum lacking, as was its impact. The *Hair* recording was approximately 22 minutes on a side, and RCA now claims they can cut as much as 26 minutes without significant level or bass reduction. This level business and the timing still seem to be problems with the discrete disc, but as with the breakthrough on the wear problem and the way things appear to be moving, I would bet that these will soon cease to have

significance. Unquestionably, the discrete disc is impressive, and despite some of the aforementioned problems, it must be taken seriously as a major contender in the four-channel disc sweepstakes.

Just to add fuel to the already brightly-burning four-channel fire, Sansui has come up with what appears to be a very substantial advance in matrixing technology. At the Los Angeles AES convention, some of us were invited to a private demonstration at a nearby hotel. A discrete quadraphonic tape was played for us, and then A/B-ed with a disc cut with the Sansui QS encoder and decoded through a new type of decoder. The results were startling. With both pop and classical selections, there was very little apparent difference between the tape and the disc. Localization and separation were very accurate and stable. Ambient material was as effectively reproduced as "surround stereo." There seemed to be little of the diffuse "amorphous" feeling typical of much matrixed quad sound. Details appeared in the July issue and the new technique involves the use of a rotationally symmetrical, variable decoding matrix (Sansui names it Vario-Matrix), controlled with the phases of the two encoded channels. The Sansui encoding system remains the same as before. This new technique is strictly in the decoding end. With it, channel separation of 15-20 dB is claimed between any pair of speakers. It is claimed that the symmetrical electrical and acoustic characteristics, both front-to-back and left-to-right, enable one to locate sound in a full circle or at the dead center of a sound field. What I heard was impressive and while I would have to live with it awhile to sort out any idiosyncrasies, it must be reckoned as a matrix system with great potential. All this intense activity on the four-channel front tells me we are going to have a very exciting New York H-Fi Show, come Sept. 26th!

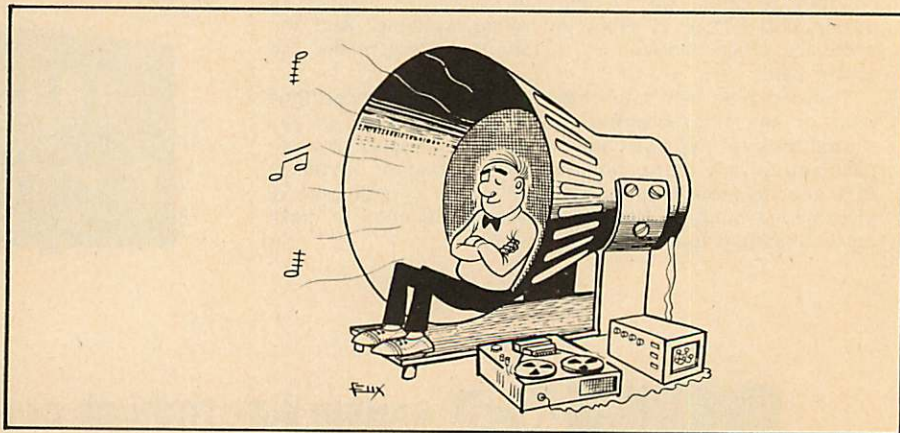

Recently a number of influential publications have said some very nice things about our loudspeakers. And we're most grateful. But reviews—even good ones—don't tell the whole story. Stated simply, the only way to judge a loudspeaker is to hear it. Pictured here are four of our best selling models. To the far left, our extraordinary little Thirty-Two (\$47.50†). Next, the very popular Seventeen (\$74.95†). Up front, the classic Six (\$134.00†). And

finally, the spectacular Five (\$189.95†). If you really want to know what KLH is all about, we suggest you listen to any one or all of these fine loudspeakers. And when you do, we're sure you'll agree that KLH delivers everything the reviews promised—and then some.

For more information, visit your KLH dealer or write to KLH Research and Development, 30 Cross St., Cambridge, Mass. 02139.

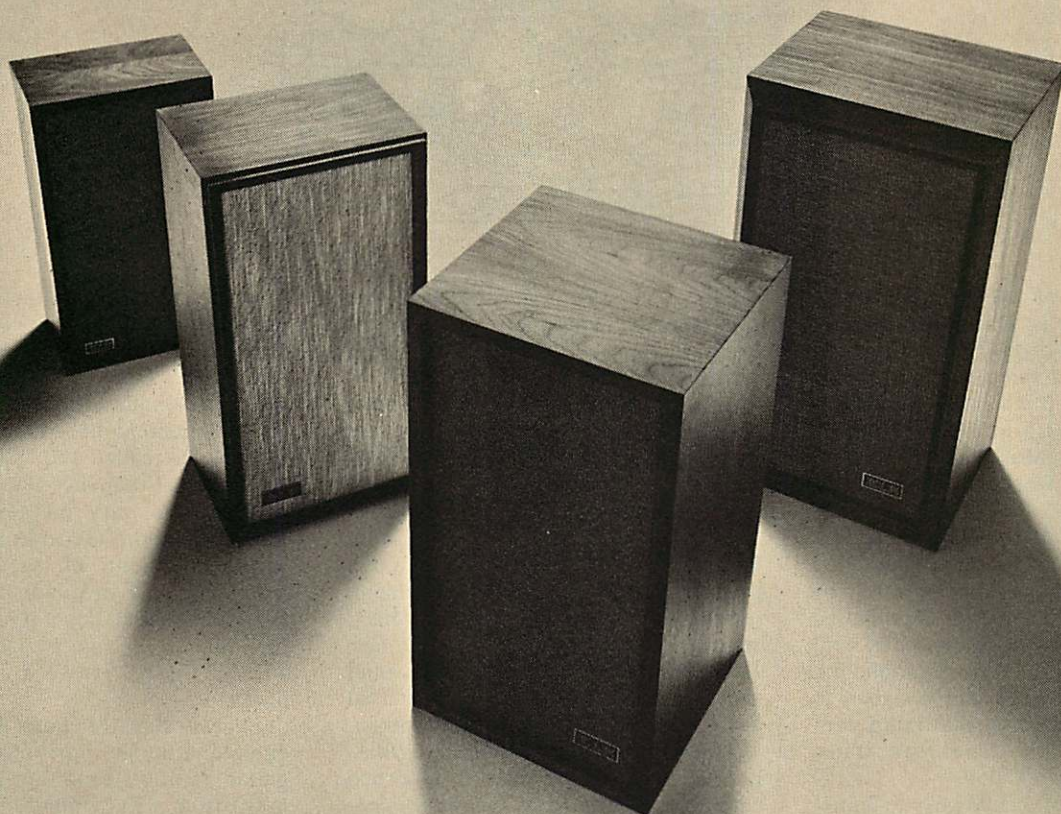

**If you think
our reviews sounded good,
wait till you hear our
loudspeakers!**



KLH RESEARCH AND DEVELOPMENT
A Division of The Singer Company

*†Suggested retail price—slightly higher in the South and West. *A trademark of The Singer Company.*

Check No. 15 on Reader Service Card

Dollars for Tapes



WINNER OF THIS MONTH'S tape contest is David Geeseka of Fort Worth, Texas, who collects \$50.00 for a splendid recording of a church organ. It was made in Broadway Baptist Church in Fort Worth and the organist was Mark Scott. The program included works by Buxtehude, Langlis, Widor, and Bach's *Prelude and Fugue in B Minor*. The organ is a large instrument of 92 ranks (including antiphonal organ) and was built by Casavant in the early 50's. David used a Revox A77 two-track recorder with E-V 676 and AKG D19E microphones. Mixer was home-built and designed to conform with the E-V matrixing configuration and the tape was transferred by a Sony TC-650.

Second prize of \$25.00 goes to James Mathews of Washington, D.C. for a recording of a trio: piano, bass, and drums. Pianist was Vince Genova, bass player Reed Watson, with James himself at the drums. The piano was a Miller 1903 grand, which James says he completely rebuilt. The piece played was an original composition by the bass player called *Reflections*, and overall sound quality, balance, and stereo image were excellent. Like David Geeseka, James used a Revox A-77 but the mics were five AKG D-19E/200's and two E-V RE-15's mixed through two Shure M-68 units. An Advent Model 100 Dolby unit was also used.

Consolation prizes of BASF low-noise tape to the following:

Leonard Gibbs of Charlestown

Heights, S.C., for a recording by the Charlestown Symphony Orchestra of Brahms' *Piano Concerto No. 2*. The pianist was not named but Leonard says he was the winner of a Young Peoples Talent Contest—and I am not surprised. Recorder was a TEAC 7030 SL with two Shure M-68 mixers, six Sony C-37 and two ECM-377 condenser mics—plus an Advent 101 Dolby unit. The piano tone was first-class although it *did* tend to be a little too prominent.

Ron Ostreicher of Detroit, Mich., sent in a rendering of Poe's *Tell Tale Heart*, complete with sound effects—and very bloodcurdling it was, too. Ron used a Sony 165 recorder with MX-6 mixer.

Mike Tennehill, of McAlester, Okla., hoped that we would be absorbed with his four-channel *musique concrete* which he entitled *Maelstrom*. The instruments used included a piano, organ, a shortwave receiver, and an audio generator—with fascinating results. We were certainly absorbed—especially with the piece entitled *Forest of Peculeia*. It was too. . . . Mike used a TEAC TCA-42, two Sony TC-630's and an Advent 100 Dolby unit but no details were given on the mikes. An excellent use of the four-channel medium.

Dudley Duncan of Ann Arbor, Mich., also sent in a *musique concrete* composition. This one was entitled *Syntonic Set*, and among the techniques employed were sound-on-sound, speed changes, dubbing, and redubbing. Flutter was introduced by dubbing

from one track to another as the tape passed on the "wrong" side of the capstan. Instruments used included reeds made from soda straws, mallets, cans, a resonant auto license plate, and an arrangement of guitar strings and coffee cans called the "Duncanharp." An Advent Frequency Balance Control was used to vary the texture and a Lafayette Audio Generator also joined in the fun! Some of the compositions were originally in quadrasonic mode but were mixed down to two-channel for this tape. The recorders were a TEAC TCA-42, Sony 355, and Sony 155 decks.

Eugene Toles of Santa Rosa, Calif., entered a mono tape recording of a guitar using sound-on-sound plus music from a TV. Output from a Fender guitar amplifier was taken direct to a Tandberg 3000X. A nice, clean tape with good dynamic range.

George Swanson of Duluth, Minn., is a Dolby enthusiast and he used a half-track Revox A-77 plus another A-77 for quarter-track dubbing. Mics were four AKG D-200's, two D-202's, and two D-224's with two Sony MK-12 mixers. The tape was quite varied and ranged from high school bands and rock groups to school choirs and community orchestras—mostly recorded on stage. Quality was good with excellent stereo image. However, I make no comment on the poem enclosed which began, "There was a young hi-fi nut from Duluth, who said 'Yoiks, this tape's good and that's the truth. . . .'"

AKAI



**Of course!
Only AKAI combines
Reel-to-Reel—Cartridge—
Cassette recording/playback...
in one tape recorder!**

It's no longer a choice between reel-to-reel, cartridge or cassette recorders! AKAI has solved the problem. You get them all!

Now you can turn on whatever turns you on. Our unique new X-2000SD Stereo Tape Recorder gives you absolute versatility.

Reel-to-Reel . . . cartridge . . . cassette . . . any way you like it. With full recording and playback capability.

That's quite a lot to put into one tape recorder.

But we didn't stop there.

We engineered the X-2000SD to enable you to record off the air, or from records, onto reel-to-reel, cartridge or cassette.

Or even to transfer your stereo music from reel to cartridge or cassette.

Which means that you can enjoy the same music you play at home in your car's 8-track player. Or on the beach with your cassette player.

There's more.

The X-2000SD is equipped with a self-contained amplifier, a 2 IC pre-amp and two 4" high compliance built-in speakers. Plus our exclusive Cross-Field Head for maximum fidelity in reel-to-reel recording. And a one-micron gap head for peak performance in cartridge and cassette recording.

Nothing's been overlooked.

So you can stop wondering which type of recorder to get. You get it **all** from AKAI. With the amazing X-2000SD. Hear it now. At your AKAI dealer.

AKAI™

**THE SWITCH
IS ON
TO AKAI**

AKAI America, Ltd. / Post Office Box 55055, Los Angeles, California 90055

For your nearest AKAI dealer call 800-243-6000 Toll Free. In Connecticut, 1-800-882-6500.

In Canada: Electronic Distributors, Ltd., Vancouver, B.C. In Mexico: Mexico International Imports, S.A., Apartado Postal 66-672, Mexico 12, D.F.

Check No. 17 on Reader Service Card

MUCH OF THIS ISSUE is devoted to phono cartridges and usually we would include a comprehensive Directory and Listing of Specifications. However, as our next issue is our Annual Directory number, listing *all* hi-fi products, we decided to omit a separate phono listing now. Phono cartridges are like loudspeakers in one respect—it is impossible to say that one particular model is superior to anything else. Some people like the bright, slightly clinical sound of Brand X, others prefer the soft, smoother sound of Brand Y. One thing is certain: There are now half-a-dozen top quality cartridges with almost state-of-the-art performance not thought possible in the early days of stereo just a few years ago. Tracking pressures have nearly reached the theoretical optimum of half a gram or so, which reminds me. . . . Many years ago, I designed a pick-up of which I was quite proud. It had a weight of *four ounces* and this fearsome beast could

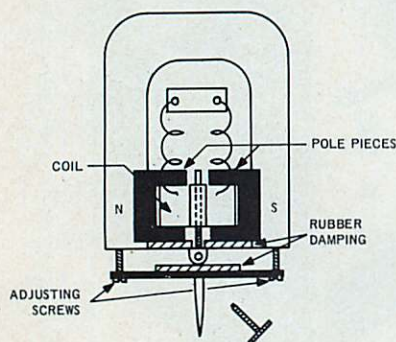

be attached to a phonograph soundbox arm by means of an adapter. Yes, it was a long time ago, but this was in England where people were (and are) a little conservative about new ideas! And, to be honest, radio sets of those days, with their crude loudspeakers, were not *that* much better than some acoustic phonographs anyway. The basic arrangement of the GWT cartridge is shown in the drawing. The two screws at the bottom are for centering the armature so that it was more or less in the middle of the pole pieces. If it was too near one side, it could suddenly fall over in a fit of perversity and stick to the pole piece—but a turn of a screw and it would clear itself, with a “thunk” from the protesting loudspeaker! This kind of balanced armature design was self-equalizing as low frequencies with their large excursions brought the armature nearer the pole pieces and so gave a higher output—really a kind of amplitude distortion! Output was high—around 250 millivolts—necessary for the radio receivers of the day. The

stylus, held in by a set-screw, was made of steel, although some purists preferred to use needles made of fiber—which could be resharpened on a piece of sandpaper until there was nothing left but the point! Anyway, this particular cartridge was quite popular but it was eventually superseded by a needle-armature type. This form of construction dispensed with the chunk of iron and set-screw and just used the needle as the armature, thus reducing the moving mass. Needle-armature pick-ups would not perform with fiber needles—a fact which perplexed a few users, including, I remember well, the operator of a PA system at a football match where there was no half-time music because the whole amplifier was disembowelled after the stylus was changed!

The Earplay Project

Earplay is a project jointly sponsored by the Univ. of Wisconsin and the Corporation for Public Broadcasting to produce drama for distribution to some 500 broadcasting stations. The director is Karl Schmidt who says, “There is no present market for drama in this country. Further, it is fair to say that there never was a consistent market for plays of literary quality. It is our attempt through the Earplay Project to create such a market. . . . Though we are attempting to reach a significant audience, we are aware of the need for a place for playwrights to try new ideas and new techniques.” I have always wondered why this country lags behind most European countries in this field. Some of the best drama on TV comes from Britain’s BBC but it has confounded the critics by being extremely popular here too! What Earplay is doing is to purchase 20 short-play scripts a year with awards up to \$1000 each. The second-year competition opens September 1, and further instructions can be obtained from Karl Schmidt, Earplay, WHA Radio, Madison, Wisc. 53706. I have often said that quadraphonics is an ideal medium for drama—perhaps Earplay can look for new ideas and techniques in this format.

CBS + E-V + ?

CBS and Electro-Voice have announced that they now have reached an agreement in principle for a non-exclusive exchange of patent rights and technology relating to their respective quadraphonic systems. Included in this exchange are the patent rights recently granted to Peter Scheiber. Adolph Wolf, President of Electro-Voice, said, “This is a major step in achieving industry compatibility.” So, now it’s up to Sansui. . . . *G.W.T.*

The Pick-Up Pros.



Artie Altro makes the WOR-FM sound, while Eric Small, Sebastian Stone and Promotion Director, Kim Olian look over a new album.

WOR-FM, the country's leading FM/Stereo rock station, has been using Stanton cartridges since its inception.

Program Director Sebastian Stone likes the smooth, clean sound the Stanton delivers; the way it is able to pick up everything on the record so that the station can assure high quality transmission of every recording.

Eric Small, Chief Engineer for WOR-FM, likes the way that Stanton cartridges stand up under the wear and tear of continuous use. "We standardized on Stanton a couple of years back," Small said, "and we haven't had a cartridge failure since. Studio Supervisor Artie Altro concurs.

Whether you're a professional or simply a sincere music lover, the integrity of a Stanton cartridge delivers the quality of performance you want.

There are two Stanton professional cartridge series. The Stanton 681 Series is engi-

neered for stereo channel calibration in record studios, as well as extremely critical listening. The 500 AL Series features design modifications which make it ideally suited for the rough handling encountered in heavy on-the-air use. In fact, among the nation's disc jockeys it has become known as the "industry workhorse."

All Stanton cartridges afford excellent frequency response, channel separation, compliance and low mass and tracking pressure. And every Stanton cartridge is fitted with the exclusive "longhair" brush to keep grooves clean and protect the stylus. They belong in every quality reproduction system—broadcast or high fidelity.

For complete information and specifications on Stanton cartridges, write Stanton Magnetics, Inc., Terminal Drive, Plainview, L.I., N.Y. 11803.



All Stanton cartridges are designed for use with *all* two and four-channel matrix derived compatible systems.

New at C.E.S.

THE CONSUMER ELECTRONICS SHOW, held this year in Chicago's McCormick Place June 11 to 14, introduces to the trade the annual crop of new (and not so new) products for the coming season. The following selection are some of those on which we had details at press time.

* * *

Pioneer receivers, decode-amp



Pioneer QX-8000A

Pioneer has introduced several new models including the QX-8000A four-channel AM/FM stereo receiver. The unit can handle discrete as well as SQ and regular matrix sources. Continuous power output per channel, 8 ohms, 4 channels driven, is 22 watts with less than 1.0% THD or IM. FM tuner specifications are 2.2 μ V (IHF), 3 db capture ratio (IHF), greater than 40 dB selectivity (IHF), and 65 dB S/N. The QX-4000 has many of the features of the larger receiver, including the decoding abilities. Its power rating is 13 watts while the FM tuner specifications are the same. The QL-600A decoder-amplifier combines with existing two-channel systems to provide discrete, SQ, and regular matrix four-channel sound. Continuous power output per channel, 8 ohms, is 10 watts.

Akai tape recorders



Akai X2000SD

This broad line includes open-reel decks and recorders, 8-track and cassette recorders, several combination units, as well as four-channel recorders in open-reel, 8-track and combination. The Model X-2000SD combines reel-to-reel, 8-track and cassette with transfer capability from one mode to another.

Features include crossfield head for open-reel operation and one-micron head for cassette and cartridge, four speeds with optional adapter, 12 watts per channel power, and two speakers. The 280D-SS four-channel tape deck features a repeat circuit for auto reverse and continuous four-channel PB, three motors, four heads, and sound-on-sound. It also offers compatible 4/2-channel recording, auto stop/shut off, and pause button with lock. The GXC-65C features the Dolby noise reduction system, Invert-O-Matic continuous repeat/reverse, and CrO₂/low noise tape biasing switch.

Superscope tuner

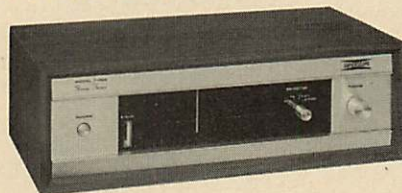

Superscope T-208

The Superscope T-208 AM/FM tuner is part of a new line of hi-fi components, said to have specifications and features associated only with higher priced components. The T-208 has high stereo separation and r.f. sensitivity and its design features include balanced fly-wheel tuning, signal strength meter, and stereo indicator. Price: \$89.95.

Kenwood adapter/amp



KSQ-400

The KSQ-400 quadrasonic adapter-amplifier features front-panel selector switch and indicator lights for four-channel AUX, SQ, Quadrix, and two channel. This rear-channel amplifier has 12/12 watts (8 ohms), while its power bandwidth is specified at 30 to 30,000 Hz. Four-way balance controls adjust front/rear and left/right balance, while the tone controls have a range of ± 10 dB at 100 and 10,000 Hz. There is a tape monitor switch for four-channel recording.

Empire Grenadier 9500MII

This new 6-driver, 3-way system uses two downward facing 12-in woofers for an acoustical equivalent of an 18-in

low frequency driver. Other components are two wide-angle lenses with 160 degree radiation, each with an individual dome tweeter and direct radiator mid-range. Quick change terminals underneath allow the speaker to be hooked up to produce a stereo image if the listening room is cramped. Built-in automatically resetting circuit breakers prevent speaker overload or burnout. Price: \$319.95; optional imported marble top, \$29.95.

Scott 500 Series

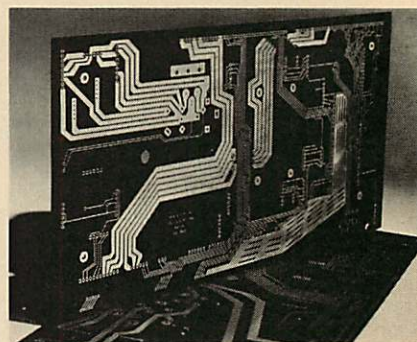

Scott 500 Series PC board

This new group of receivers from Scott makes use of printed circuit masterboards to carry all signal and power circuitry and eliminates all discrete wiring except for transformer leads and dial pointer wires. All audio and r.f. signals travel only on PC board paths, which results in greater consistency between units, more accuracy in performance specifications, and easier assembly, testing, service and replacement. The Model 525 is a 100 watt per channel, 8 ohms, AM/FM stereo receiver priced at \$599.90; the Model 554 is a two or four-channel AM/FM stereo receiver, convertible between 2x60 and 4x25 watts, priced at \$549.90.

Fisher quadrasonic receivers



Fisher 504

Models 504, 404, and 304 AM/FM stereo receivers with built-in SQ decoders adapt from four to two channels by combining or "strapping" the outputs of the four amplifiers in pairs via a front panel switch. Power output per channel in two-channel operation is thus double that per channel in the



It stopped the traffic in Times Square.

We took our new ST-5130 FM stereo/FM-AM tuner to Times Square, where traffic — and ignition interference noise — are at their peak. Then with a flick of a switch, we stopped the noise dead.

That switch cuts in our new, exclusive, Impulse Noise Suppression circuit. It instantaneously cuts out the man-made impulse noises that can plague FM reception.

With this background interference gone, it's easy to hear and appreciate the rest of the 5130's super-tuner performance. The numbers are unbeatable: 1.5

uV IHF, sensitivity, 1.0 dB capture ratio, 100 dB selectivity, and 100 dB rejection of images, i.f., and spurious response (with equally remarkable AM performance, of course).

And you'll also like such features as the 5130's oscilloscope output jacks for multipath indication, and its independently-controlled headphone jack.

Impulse Noise Suppression. Hear the difference it makes, at your nearby Sony Dealer. Sony Corporation of America, 47-47 Van Dam Street, Long Island City, N.Y. 11101.

New **SONY ST-5130 FM Stereo/FM-AM Tuner**

"If you live in New York, Philadelphia, Hartford, Baltimore, or Boston, check your local station listing for the Schaefer Music Festival brought to you in SQ by Sony and Schaefer."

Check No. 21 on Reader Service Card

New at C.E.S.

quadraphonic mode. Volume and tone controls are slider types with five tone bands on the 504, three on the 404, and two on the 304. The 504 and 404 have "joystick" master balance controls and center-channel and signal strength meters. The 304 has individual front and rear volume controls and a signal strength meter. All three have front and rear headphone jacks as well as loudness, FM noise, and interstation muting filters. Continuous power output per channel, quadraphonic mode, 8 ohms, 20-20,000 Hz, is 32 for the 504, 22 for the 404, and 15 for the 304. All three have identical FM tuner specifications: 1.8 μ V sensitivity (IHF), 1.2 dB capture ratio (IHF), 56 dB selectivity (IHF), 68 dB S/N, and 0.3% THD (stereo). Prices: 504, \$499.95; 404, \$399.95, and 304, \$299.95.

Koss headphone



Koss HV-1

Claiming a major innovation in "hear-through" headphone design, Koss has announced the HV-1, which allows some outside sound to be heard while delivering high quality extended bass reproduction. This was made possible, says Koss, by the development of a quality lightweight velocity driver element. The entire set of phones weighs 9 ounces and is priced at \$39.95.

Sony receiver, decoder, amp



Sony SQR-6650

Model SQR-6650 AM/FM stereo receiver has decoding circuitry for SQ

and other matrix systems, and can handle discrete four-channel sources as well. Total power output in quadraphonic mode is 32 watts rms into 8 ohms; in two-channel, 50 watts rms. Four VU meters light up in quadraphonic, two in two channel. FM tuner performance is specified as 2.2 μ V sensitivity and 70 dB selectivity. Price: \$329.50. The SQD-2000 decoder includes new wave-form comparator logic (plus front-rear logic) to increase separation for signals at the edge of the front and rear sound fields. The design, which includes three separate sets of four-channel inputs, allows addition to an existing two-channel system or use in a new quadraphonic installation. Price: \$299.50. The TA-1150 integrated two-channel amplifier will operate with any type of four-channel converter, whether designed for SQ or any other system. Power output is 30 watts per channel rms, 8 ohms, 20 to 20,000 Hz, 0.2% THD or IM. Other features include two speaker system facilities, two inputs each for tape, phono, and AUX, and tone controls with two-position switches to adjust the frequency at which the controls take effect. Price: \$229.50

JVC receiver, tuner, amp

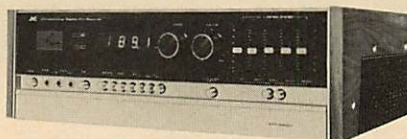

JVC VR-5660

The VR-5660 features digital readout for FM tuning and clock, together with SEA tone controls. Power output is 90 watts rms per channel with 0.4% THD or IM. FM tuner specifications are 1.7 μ V sensitivity, 0.8 dB capture ratio, and 40 dB separation. Price: \$699.95. The VT-900 tuner has digital readout, and IC and FET circuitry, with dual-element FM filters. Specifications are 1.7 μ V sensitivity, 0.8 dB capture ratio, 70 dB selectivity, and 0.3% THD, mono. Price: \$399.95. The VN-900 amplifier features a pink noise tester and SEA tone controls. RMS power output is 60 watts per channel, 8 ohms, while THD and IM are rated at 0.25% and 0.4%, respectively, at claimed power. Price: \$349.95.

Dokorder tape deck

The Model 9100 deck features a 6-head, 4-track design with bi-directional record and playback, auto reverse and repeat,

auto stop and auto switchover from fast wind to playback. Frequency response is specified as 40 to 21,000 Hz \pm 3 dB, S/N as better than 55 dB, and wow and flutter as less than 0.06%, all at 7 1/2 ips. Other features include tape counter memory which automatically stops the tape during fast forward at any pre-set point, tape tension switch.

Audio Research speaker

The Magneplanar speaker from Audio Research uses a distributed magnetic field, has a thin mylar diaphragm, is thin with large area, and has bi-polar radiation. It is purely resistive, with essentially no inductive or capacitive reactance. It requires no high voltage supply, step-up transformer or crossover. Claimed frequency response is 30 to 20,000 Hz with good high frequency horizontal dispersion and stereo imaging. Size is 6 by 4 ft. by 1 in. Price, per pair: Under \$1000.

Panasonic modular quadraphonic system



Panasonic Rosemead

The Rosemead, Model RE-8840, is a custom four-channel stereo music center with a car-convertible 8-track, four-channel player and AM/FM stereo radio with built-in four-channel balance scope. Each of the four speaker systems contains an 8-in. woofer and 2 1/2-in. tweeter. Other features include an external four-channel balancer jack, FET tuner, AFC on FM, built-in antennas, and optional cassette adapter. Price: \$379.95. Three other quadraphonic modular systems introduced by Panasonic are the Anandale at \$399.95, the Holbrook at \$299.95, and the Whittier at \$279.95. The RS-263US cassette deck features the Dolby noise reduction system, CrO₂/conventional tape bias switch, memory rewind, auto off, lockable pause control, and dual VU meters. Price: \$179.95.

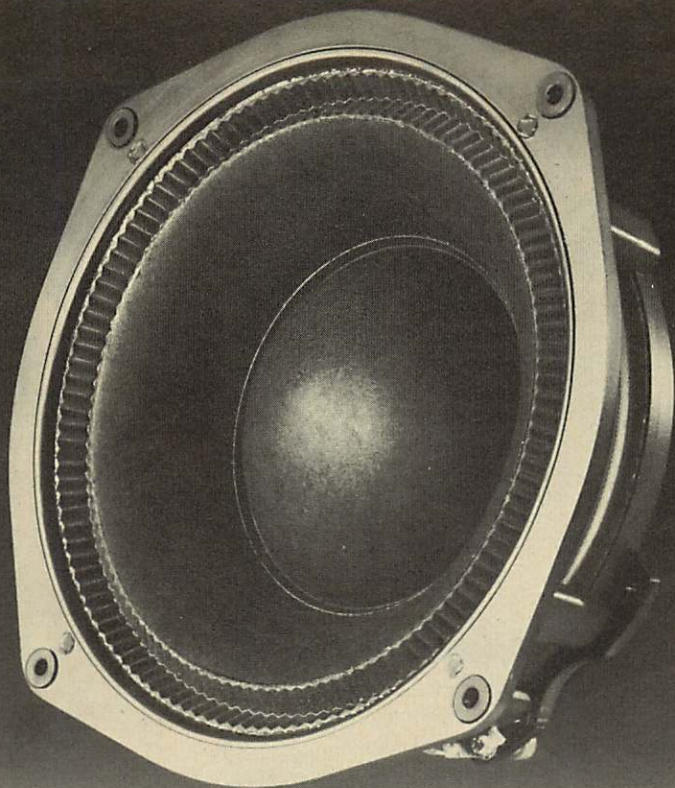

The patented gathered edge suspension that yields to extra-soft or extra-heavy bass without surrendering.

After hundreds of experiments Hitachi engineers have produced a unique suspension woofer that provides high linearity, yet prevents partial vibrations.

Hitachi's patented gathered-edge suspension features 120 precision gathers with 480 faces. This results in a cone paper that is able to move in exact proportion to the resonant frequency flow. Even those problematic bass transients—timpany strokes and tube blasts—come through with effortless ease and crispness.

To achieve even greater sound quality Hitachi has acoustically balanced gathered-edge suspension with our unique bass reflex enclosure and linear horn tweeter. The bass reflex enclosure design diverts sound waves generated at the rear of the woofer and channels them to the front. This gives a fuller bass response even at low

listening volumes. With the linear horn tweeter an acoustic lens spreads high range sound over a wide angle. This permits a free choice of listening positions instead of the usual "fixed" position locations.

In receivers, Hitachi features the extensive use of LTP (Low Temperature Passivation) transistors. This reduces amplifier noise to practically nil and results in the world's finest FM tuner sensitivity. We were also the first to adopt ITL-OTL circuitry to eliminate distortion and deterioration of frequency characteristics.

It's advances like these that have lead Hitachi to name its systems Maxi-Fi® rather than hi-fi. There's a complete line of Maxi-Fi® components—receivers, integrated amplifiers, FM tuner, speaker systems, record players, decks—everything for the individual taste and budget.



For more on the Maxi-Fi® systems, write, Dept. A-1, Hitachi Sales Corp. of America, 48-50 34th Street, Long Island City, N. Y. 11101

Quality always comes first at
HITACHI

Check No. 23 on Reader Service Card

Our very remarkable crowd pleaser.

The ADC 303AX.

Without a doubt, the most popular speaker we've ever made.

Time and again, enthusiastic owners have written to tell us how very pleased they were with the 303AX. Fantastic... outstanding... beautiful... and remarkable were among the more common-place accolades we received.

As for the experts, they expressed their pleasure in more measured phrases such as, superb transient response, excellent high frequency dispersion, exceptionally smooth frequency response and unusually free of coloration.

Obviously, a speaker like the ADC 303AX doesn't just happen.

It is the result of continually designing and redesigning. Measuring and remeasuring. Improving and then improving on the improvements. All with only one goal in mind...

To create a speaker system that produces a completely convincing illusion of reality.

And we believe that the key to this most desirable illusion is a speaker that has no characteristic sound of its own.

We've even coined an expression to describe this unique quality... we call it, "high transparency".

It's what makes listening to music with the ADC 303AX like listening back through the speaker to a live performance.

And it is this very same quality that has made our very remarkable crowd pleaser the choice of leading audio testing organizations.

Finally, a pleasing word about price. Thanks to steadily increasing demand and improved manufacturing techniques, we've been able to reduce the already low price of the very remarkable ADC 303AX to an irresistible \$90*.

That could make it the most crowd pleasing buy in high fidelity today.

*Other ADC high transparency speaker systems available from \$45 to \$150.



Audio Dynamics Corporation

Pickett District Road, New Milford, Connecticut 06776

Check No. 24 on Reader Service Card

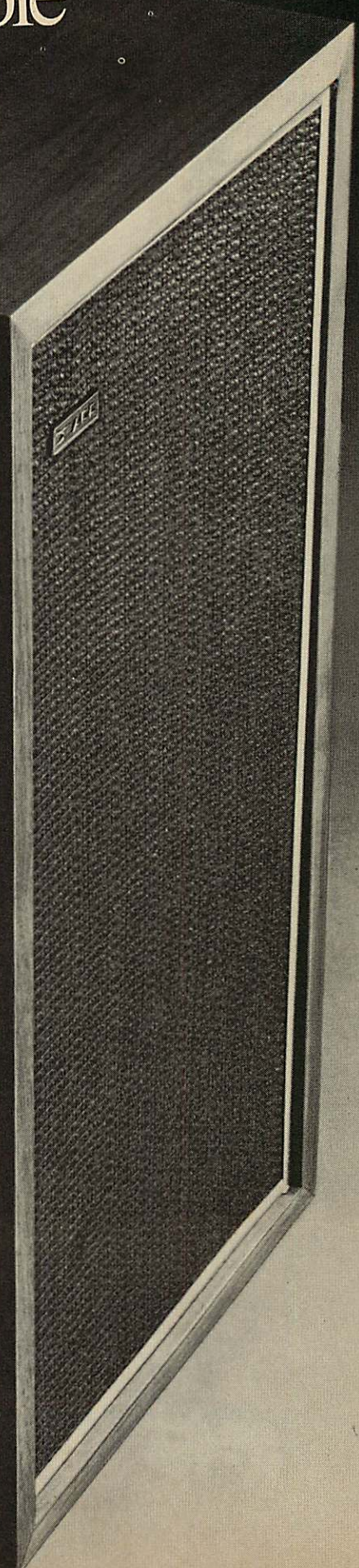

THE LANGUAGE OF HIGH FIDELITY

Part III - Basic Electronic Components -continued

Martin Clifford

EVERY HOME has a crying need for storage space, with the housewife usually doing most of the crying. An analogous situation exists with FM components, such as tuners, receivers, and amplifiers, for the concept that electric currents must be continuously on the go is quite erroneous. There are times when it is necessary to store a voltage, thriftily squirreling it away for later use.

It would also seem, in this context, that voltage and current are used synonymously. A current consists of the movement of electrons, each carrying a negative charge. Stop this flow of current to allow the electrons to accumulate on some conducting surface, such as a metal plate, and you have a voltage. The electrons, now in a static condition, strain to be off elsewhere, to distribute themselves from a crowded to a much less so condition. This effort, also known as electromotive force (or emf), or potential difference (or PD), or voltage, exists between any area having a multiplicity of electrons and any adjacent, less electron-packed region. Once the electrons are allowed to move, we have an electric current. And so electrons supply both voltage and current.

Electronic high-fidelity components pose a three-part problem: 1. to generate a voltage; 2. to let various currents flow along designated paths, and 3. to store electrons as the circuit and occasion require. Any battery or generator can produce a voltage; any conductor can supply an easy path for the movement of current. The problem, then, is how to store electrons.

The problem of generation, transmission and storage isn't new, for it has existed since the beginning of electricity as a science. Oddly enough, early experimenters in electricity solved the difficulties of transmission and storage first, while the generation of voltage came in a poor third.

The First Electron Storage Concept

The first device for the storage of electrons was a glass bottle, partially filled with water. The bottle had an insulating stopper and coming down through this stopper was a metal rod, just long enough to reach slightly below the surface of the water. The remaining element of this contraption, called a Leyden jar, was human fingers wrapped around the bottom part of the jar. And this was the inelegant ancestor of one of the essential parts you will find in high-fidelity components—the capacitor.

The human body with its various extremities is an electrical conductor. So is water, provided it is contaminated, preferably with some kind of acid, base or salt. Fortunately, the original inventors of the Leyden jar were more concerned with electricity than with water quality. Pure water isn't a conductor. How strange to think the capacitor might not have been discovered if its inventors had worked in a scrupulously clean laboratory.

The Leyden jar, invented by Ewald Georg von Kleist, at one time Dean of the Cathedral of Kamin in Pomerania was also invented independently by Professor Pieter von Musschenbroek of the University of Leyden, in Holland, about 1745. Subsequently, this primitive capacitor was improved by surrounding the lower portion of the jar with a metallic coating, while the water was replaced by iron filings. Finally, one investigator, Dr. John Bevis, came to the conclusion that the shape of the Leyden jar had no influence on its behavior and used a flat section of glass coated with tinfoil on both sides. The Leyden jar is a museum curiosity but the Bevis arrangement would be recognized today as a capacitor.

When he wasn't busy flying a kite, inventing the lightning rod, or the Franklin stove, fomenting a revolution, or developing the concept of positive

and negative in electricity, Benjamin Franklin meticulously and methodically studied the behavior of the Leyden jar and correctly concluded that the positive charge on one side of the glass was equal to the negative charge on the other side. He also discovered that the amount of charge could be increased or decreased by varying the thickness of the glass and the areas of the conducting surfaces, basic concepts still valid in the manufacture of capacitors. And so, even if indirectly, Franklin made a substantial contribution to high-fidelity electronics.

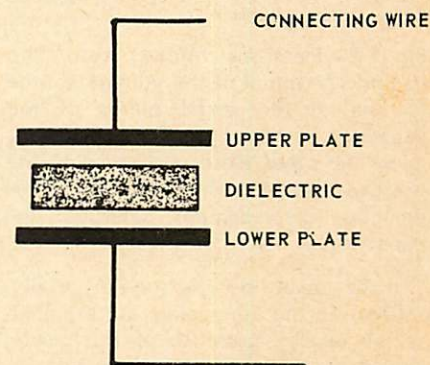

Fig. 1—The basic capacitor consists of a pair of metal plates and a non-conducting dielectric.

The Charged Capacitor

The ancestral capacitor consisted of two sheets of metal separated by glass. Glass is an insulator, a non-conductor of electricity, and in its position in a capacitor is called the dielectric (Fig. 1). Modern capacitors use just about anything and everything that will not conduct as a dielectric: paper, mica, ceramic materials such as titanium dioxide and barium titanate, mylar-coated paper, thin plastic film or thin oxide film, bakelite, castor oil and mineral oil.

When connected across a d.c. voltage (Fig. 2) the relatively substantial plate

area of the capacitor represents an unexcelled opportunity for the electrons crowded on the negative terminal of the battery to migrate. The voltage source can also be a d.c. generator or the d.c. output of a power supply. To the capacitor the voltage source is an electron source. To the voltage source, the capacitor represents a chance for electrons to get away from it all. And so there is an electron movement from the voltage supply onto the capacitor plate connected to the minus terminal. But the electrons are now trapped in a cul-de-sac, a dead end. Having arrived at the capacitor plate, there is no place for them to go. The nearest available area is close by but is blocked off by a glass plate.

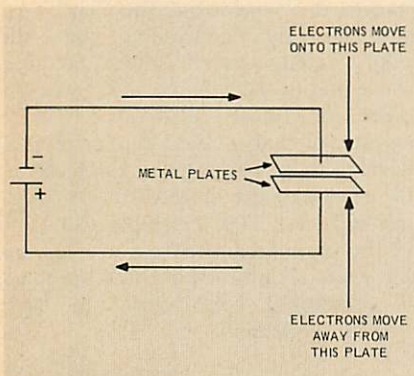

Fig. 2—Electrons move from the negative terminal of the voltage source to one of the metal plates of the capacitor. An equal number of electrons leave the other plate and move to the positive terminal of the battery. This electron displacement charges the capacitor.

In the meantime electrons originally resident on the other plate are repelled by the nearby presence of the newly arrived electrons on the other side of the glass, and so they in turn escape to the positive terminal of the battery.

We now have a condition in which one plate has an electron excess, while the other has an electron shortage. Consequently, there is a pressure between the two plates caused by this electron imbalance, more technically known as a voltage. At the moment the capacitor was connected across the terminals of the battery, the capacitor voltage was zero. With the movement of electrons onto the capacitor plate, the pressure between the plates increases until it becomes equal to that of the electron-supplying voltage source. No further electron movement takes place, the electrons on the capacitor plate firmly opposing any further movement from the source. The

voltage across the capacitor and that of the source are now equal. The capacitor is fully charged.

Electron Storage

Electrons are now stored on one plate of the capacitor. They can be led away by connecting conductors to the capacitor plates, possibly to some circuit or part. The point is that the electrons will remain where they are until required. The capacitor is an electron reservoir.

Amount Of Electron Storage

Storage implies capacity. In terms of capacity, a gallon of wine is superior to a fifth of Scotch. Similarly, some capacitors are designed to hold or store a relatively small number of electrons; others are intended to pack away huge quantities. The amount of storage is a function of the work to be done by the capacitor, leading to such gem-like clichés as “never send a mica capacitor to do the work of an electrolytic.”

The basic unit of capacitance is the farad, named in honor of Michael Faraday (1791-1867). Unfortunately, the farad is an enormously large unit, somewhat akin to a 10,000-acre ranch being seriously proposed as a modest back garden for a four-room cottage. A more realistic unit is the microfarad, or one-millionth of a farad. A most unlikely capacitor having a capacitance of one farad could be replaced by a million capacitors each having a rating of one microfarad. And even the microfarad is sometimes too large, for it, in turn, could also be replaced by a million capacitors each having a value of one picofarad. A picofarad is one-millionth of a microfarad which, in turn, is one-millionth of a farad. A most nonsensical way of designating capacitance, but there it is. The only order in this semantic chaos was the recent substitution of picofarad for micromicrofarad. Picofarad and micromicrofarad are synonymous, with picofarad as the preferred word. Still another gain was the replacement of capacitor for condenser, the original name selected for this unit. Condenser was replaced by capacitor when engineers realized that a pair of metal plates separated by a dielectric didn't condense anything. That took quite some time, though.

Abbreviations For Capacitance

The abbreviation for farad is F. For microfarad it is μF with the Greek letter mu as the substitute for micro. Logically, micromicrofarad would be $\mu\mu\text{F}$, but the preferred designation is now pF. To compound electronic confusion, you will sometimes see μF

written as mf, mF, mfd, MFD, μfd , or other variations. Similarly with $\mu\mu\text{F}$.

Capacitance Conversions

It's easy enough to convert from one unit of capacitance to another since it's just necessary to divide or multiply by a million. The trick is to remember your direction, for if you go the wrong way the error is a beaut.

To change farads to microfarads, multiply farads by a million. To change microfarads to picofarads, multiply microfarads by a million. Divide if you want to move the other way. To change picofarads to microfarads, divide microfarads by a million. And to go from microfarads to farads, divide microfarads by a million. The easiest way to divide or multiply in the decimal system is to move the decimal point to the right or left the required number of places (Fig. 3). Sound difficult? It just needs a little practice.

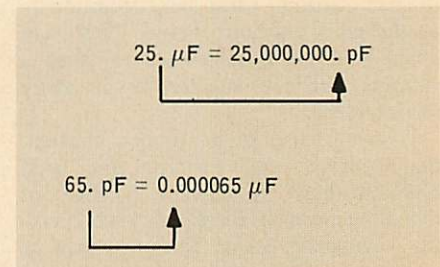

Fig. 3—Conversion from microfarads to picofarads, and vice versa, is more easily accomplished by moving the decimal point.

Capacitor Designations

Capacitors are not only identified by the amount of capacitance but by some physical characteristic as well. A mica capacitor is so called because its dielectric is mica; a silver mica capacitor uses a silver plating on the dielectric in lieu of plates; a disc capacitor has a disc-like shape; a paper capacitor has a paper dielectric.

Capacitors are sometimes named for the work they do: a bypass capacitor will bypass or supply a detour for unwanted signals. Some names used in connection with capacitors are meaningless unless you are circuit-wise: filter capacitors, neutralizing capacitors, padders, all relate to electronic functions in particular circuits.

Working Voltage

A voltage is pressure and the ability of a capacitor to withstand that pressure is known as d.c. working voltage, abbreviated DCWV. A capacitor rated at 100 DCWV means the capacitor should be able to tolerate this amount of

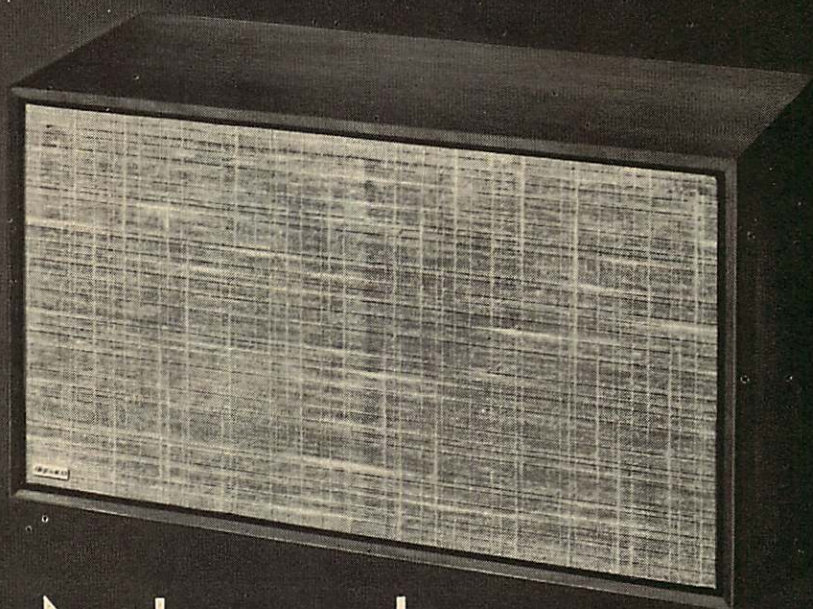

New! dynaco A-35 loudspeakers

Accuracy—the new A-35 is your next step towards sonic perfection. This slightly larger brother of the A-25 refines that speaker's acknowledged performance. The high end benefits from slightly extended range and subtly smoother dispersion characteristics. More definition, and smoother blending of the two drivers is observed in the midrange, for added "presence". The low end is even more articulate, more crisply defined. The deep bass is there all right—minus any trace of "boom". Dynaco's exclusive two-chamber cabinet provides ideal aperiodic dual-spectrum damping; variable volume action for mid-bass control, plus the advantages of a sealed enclosure for the bottom octave. 5-step tweeter control and concealed wall mounts are included.

A special 4-D DYNACO/Vanguard LP is available now. Send \$2.95 to us, or see your Dynaco Dealer.

\$119.95 in walnut

dynaco inc. Division Tyco

3060 JEFFERSON ST., PHILADELPHIA, PA. 19124

In Canada write: DYNACO OF CANADA LTD., Montreal, 760, Quebec, Canada

pressure. The working voltage of a capacitor depends on how the capacitor is manufactured, and on the ability of the capacitor dielectric to deny passage to the electrons crowded on one side of it. Generally speaking, the higher the DCVV of a capacitor, the more it costs. A very low-priced tuner or amplifier may use capacitors having marginal voltage ratings. A quality component will use capacitors having substantial d.c. working voltage margins.

Color Codes For Capacitors

Color codes are used to indicate the amount of capacitance for paper, mica and ceramic units. Colors are also used to indicate d.c. working voltage, tolerance, temperature coefficient, and capacitance drift. (Fig. 4 through 7). Color coding always refers to capacitance in pF. Unfortunately, there are quite a number of different color coding arrangements, and, in some instances, all information regarding a capacitor is completely omitted. Capacitors can be so small that information color coding is impractical. Sometimes capacitors are made for specific applications by manufacturers and since the capacitors aren't intended for commercial sale they won't be marked or else will be marked by a special code designed by the manufacturer. When a capacitor is large enough, the information may be printed on it (Fig. 8).

At one time in the electronics industry, capacitors and resistors had

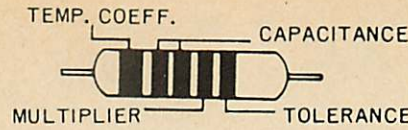

Fig. 4—This is one method of coding used for tubular ceramic capacitors.

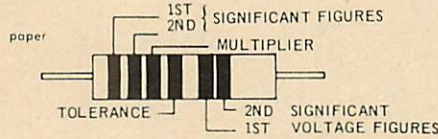

Fig. 5—One type of coding used for tubular paper capacitors.

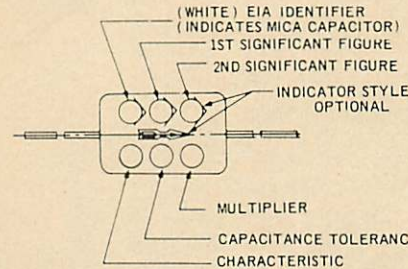

Fig. 6—Six-dot coding for mica capacitors.

distinctive shapes and so it was always easy to distinguish between them. But with an increasing variety of resistors and capacitors and with miniaturization of these parts, plus absence of coding,

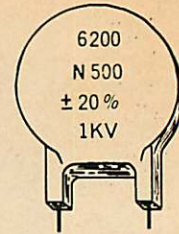

Fig. 8—If the surface area is large enough, the data is printed directly on the body of the capacitor.

it is often difficult to determine when a part is a resistor or a capacitor without the use of test instruments.

Dielectric Constant, K

The amount of capacitance of a capacitor depends on the total area of the plates, the kind of dielectric used, and the separation of the plates. The larger the plate area, the greater the capacitance, and the closer the plates are to each other, the greater the capacitance.

The effect a dielectric has on capacitance is known as its dielectric constant, represented by the letter K. Air has a K of 1, but if mica is inserted between the plates of the same capacitor, its total capacitance may be increased as much as 5 to 7 times. Mica, then, has a K of 7. Some ceramic materials have a K of several hundred, giving manufacturers an opportunity to pack a tremendous amount of capacitance in a small space.

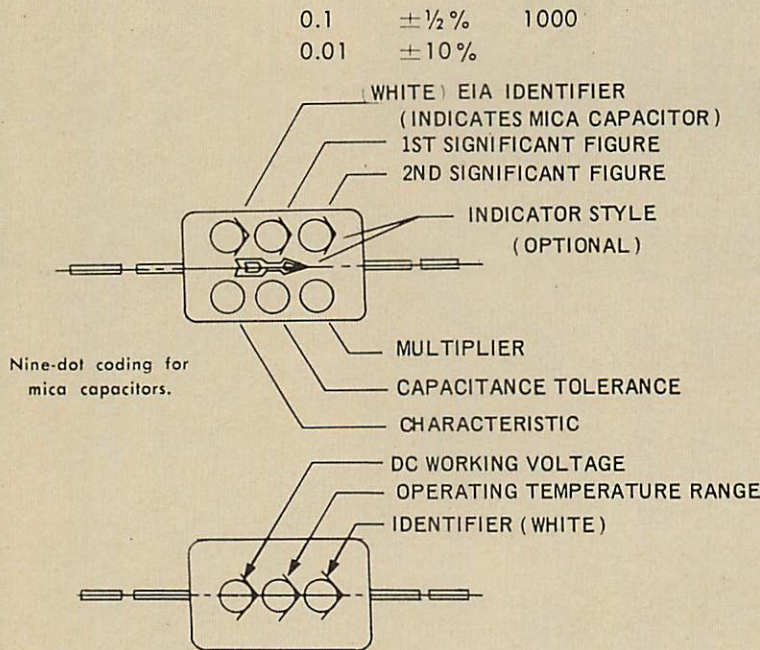

Fig. 7—Nine dot coding for mica capacitors. Both sides of the capacitor are used in this coding system.

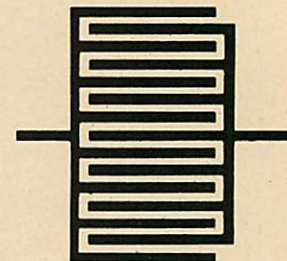
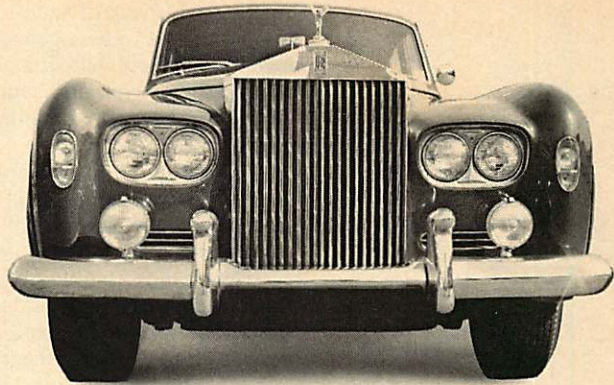

Fig. 9—To increase total capacitance a number of plates may be used.

Various techniques are used to increase plate area (Fig. 9). A number of plates may be used, with all plates on one side of the dielectric connected and all plates on the other side similarly joined. Thus, a capacitor with a large number of plates may have just two connecting leads. Another method is to etch the plate area to make it rough rather than smooth, increasing surface area. And in some capacitors the plates are made of extremely thin aluminum foil. A fairly long roll occupies little space.



Choosing the wrong cartridge for a record player is like putting the wrong motor in these cars.

Each of these cars has its own fine motor.

But, it would be unwise to expect the lower horsepower engine to efficiently drive the larger vehicle. And, it would be silly to use the higher horsepower engine for the smaller car.

It's the same with cartridges. In fact, a cartridge that's great for one record player *could be disastrous for another*. How then can you be certain you are playing your records with the right cartridge? The answer is simple.

There is a Pickering XV-15 DCF-Rated Cartridge for the most simple to the most complex playback equipment! We have taken virtually every high fidelity record player and pre-analyzed the vital engineering variables affecting cartridge design, so that no matter what equipment you own or plan to

purchase, you can get an XV-15 cartridge exactly right for it.

If you're concerned about improving your reproduction, we refer you to our handy DCF guide shown below. (Why not clip it out for handy reference?)

Every Pickering XV-15 cartridge features the exclusive DUSTAMATIC® brush that sweeps record grooves clean to insure cleanest sound.

If you'd like a DCF guide for a friend or additional information on Pickering cartridges, write Pickering & Company, Inc., 101 Sunnyside Boulevard, Plainview, N.Y. 11803.

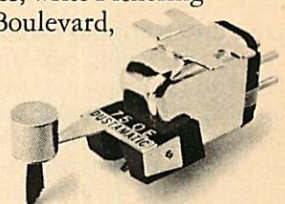

Cut out this handy DCF Guide.

IF YOU OWN	MODEL NUMBER	Use a Pickering XV-15 cartridge with this DCF Number	
		ELLIPTICAL	SPHERICAL
Acoustic Research	XA	750, 400	350
Benjamin Miracord	50H, 750, 770H	750	350
	40H, 40A, 40, 630, 620, 610, 18H, 10, 10F, 10H	400	
Dual (United Audio)	1219, 1209, 1019, 1215, 1015, 1015F, 1218	750	350
	1009SK, 1009F, 1009	400	
	1212, 1010A, 1010	200	150
Fisher	502, 402	750, 400	350
	302	200	150
Garrard (British Industries)	SL95B, SL95, SL75B, Zero 100	750, 400	350
	SL75, LAB80MK11, LAB80	400	350
	SL72B, 70MK11, A70, 60MK11, SL65B, SL65, SL55B,	200	150
	SL55, SP20B, SP20, A, AT60, AT6 40, 40B, 50MK11, 50, 40MK11	140	100
Lenco	L-75	750, 400	350
McDonald (BSR)	810	750, 400	350
	600, 610, 500A	200	150
	510, 500, 400, 310	140	100
Pioneer	PL-30	750	350
	PL-25, PLA-25, PL-41C, PL40F, PL-41A	400	
Perpetuum-Ebner	PE-2018, PE-2038, PE-2020, PE-2040	750, 400	350
Rabco	ST-4	750, 400	350
Sony	TTS 3000, PS 1800A	750, 400	350
Thorens	TD 125	750	350
	TD 150AB, TD 124	400	

All Pickering cartridges are designed for use with all two and four-channel matrix derived compatible systems.

Check No. 28 on Reader Service Card

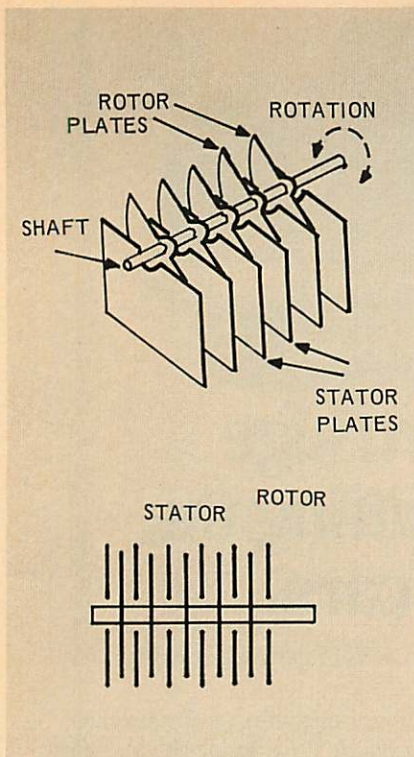

Fig. 10—A variable capacitor consists of a number of fixed plates, all connected, called the stator. The rotor plates are mounted on a shaft which can be turned.

Fixed and Variable Capacitors

Fixed capacitors are those whose plates are firmly positioned and cannot be changed. A variable capacitor, as its name implies, is one whose capacitance can be altered easily and smoothly by varying the position of one set of plates (the rotor) with respect to the other (the stator) (Fig. 10). These capacitors, used for tuning the front-ends of tuners or receivers, most often have air as the dielectric, but other dielectrics have been used. Variable capacitors use a set of rotor plates mounted on a shaft controlled by a knob from the front of the tuner or receiver. A number of variable capacitors can be mounted on a common shaft so that a single turning effort will rotate the plates of two, three or more capacitors. Thus, the rotor plates can be used to tune either one or several circuits simultaneously. With two or more variable capacitors mounted this way, the unit, known as a ganged capacitor, will have a set of stator plates for each rotor. A three-gang capacitor is really three individual capacitors linked by having a common rotor. In a receiver such a capacitor could be used to tune the radio-frequency (RF) amplifier, the local oscillator, and also the mixer.

In the early days of radio, prior to the invention of the ganged variable capacitor, these circuits had to be adjusted individually, and so those early sets had three tuning dials, not one.

Another type of variable capacitor is the setscrew adjust type used where a fairly precise amount of capacitance is required. Once the correct amount of capacitance is obtained, no further adjustments are made, and the capacitor then functions as a fixed unit. In receivers and tuners these are quite critical and are factory adjustments. It is highly inadvisable to change their settings without considerable know-how backed up with adequate test instruments.

Electrolytic Capacitors

Sometimes very high values of capacitance are required. One type, specifically designed to supply this need is the electrolytic, differing from the others in the dielectric used and in the plate material. Essentially, an electrolytic capacitor consists of long rolls of very thin aluminum foil of high purity separated by an electrolyte such as boric acid. During manufacture the capacitor is placed across a d.c. voltage and in this process an extremely thin film of oxide is formed on the surface of the foil connected to the plus terminal of the charging source. Because the oxide film is so extremely thin, the aluminum foil plates are remarkably close to each other. To increase the capacitance, the foil plates may be etched to increase the surface area. These features, plus the fact that the aluminum foil is extremely thin, permitting long lengths of it to be rolled up inside the capacitor housing, result in large amounts of capacitance. Unlike other capacitor types, electrolytics are polarized; they are marked with plus and minus signs. The plus terminal of the electrolytic is connected to the plus terminal of a voltage source and the negative terminal of the capacitor must be wired to the minus side of the voltage.

Electrolytics are generally larger than other capacitor types and so data color coding isn't used. Instead, the information is printed directly on the capacitor case. Basically, this consists of the capacitance, the d.c. working voltage, and plus-minus symbols to indicate the polarity. Sometimes two or more electrolytics are mounted in a single case, with identifying symbols on the case to indicate each capacitor.

Capacitor Leakage

Capacitors at work in high-fidelity

systems are subjected to a variety of stresses and strains, all calculated to reduce their effectiveness, resulting in a variety of troubles easily placed under one heading—sound degradation. Capacitors may be exposed to high temperatures inside high-fidelity components, or to humidity. Every capacitor, of course, must endure the strain of receiving electrons and losing them. Transient voltages, voltages far in excess of normal operating conditions, can cause a capacitor to lose some of its electron storage ability. Dust accumulating between the capacitor terminals can add its mite to the capacitor's less-than-pleasant working conditions. And finally, tiny impurities in the dielectric may represent potential weak spots.

Capacitor leakage, as its name implies, means that some of the electrons stored on one of the plates, manage to find a path through the dielectric to the other plate. Insofar as the electrons are able to do this they are no longer available as storage electrons, meaning that some circuit dependent on the capacitor for its electron supply will not receive the required amount. The effect in a hi-fi system may not be noticed or may be highly annoying, depending on the seriousness of the leakage and the number of capacitors engaged in this activity. Some capacitors have higher leakage characteristics than other types. Electrolytics have this disadvantage because of the extremely thin dielectric used and also because such capacitors are frequently subjected to very high potentials.

Leakage is minimized by using dielectrics of greater purity, by sealing the capacitors so thoroughly that no moisture can possibly enter, making them impervious to humidity, and by strict quality control during manufacture. Quality capacitors aren't to be found in bargain basements.

Capacitor Types

Capacitors are available in just about every conceivable size, shape and style (Fig. 11). Physical size may be of importance to a manufacturer in the construction of high-fidelity components for it is sometimes necessary to pack a tremendous number of parts into a limited space. Replacement of a capacitor in a high-fidelity component, then, means not only strict attention to such factors as capacitance, tolerance, leakage, and working voltage, but to physical size as well. A replacement capacitor must be able to fit into the space allotted to it.

If you're going to steal an idea, steal from the best.



"When the Citation components were in their final design phases we had the rare opportunity to see some of the first engineering prototypes and we have never quite gotten over the dedication and enthusiasm exhibited by the highly qualified engineering team that 'gave birth' to those winners.

Small wonder, then, that we were elated to find that the Model 930 receiver is the brain-child of that very team. It abounds in Citation features, many of which one would have thought impossible to incorporate in a receiver at this attractive price. Of course, the Citation 12 boasts more power (60 watt rms per channel), but then again the [Citation 11 preamplifier and the Citation 12 power amplifier] combination retails for a cool \$600.00 or so, as opposed to just under \$400.00 for this receiver. The rest of the circuit refinements are there, though, including the twin power supplies (not negative and positive voltages supplied by one power transformer, but actually two complete power supplies including two separate power transformers), super-wide frequency response and power bandwidth, fantastic square wave response and rise time, and conservative and meaningful power ratings that can serve as a model to the rest of the industry. All this plus a superior tuner section make the 930 a receiver that even the died-in-the-wool 'separatists' should take a good look at."

Audio Magazine, June, 1972

FOR THE COMPLETE REVIEW OF THE 930 AND FURTHER INFORMATION ON THE HARMAN/KARDON LINE, WRITE: HARMAN/KARDON, INC., COMMUNICATIONS DEPT., 55 AMES COURT, PLAINVIEW, NEW YORK 11803.

Distributed in Canada by Harman/Kardon of Canada, Ltd., 9429 Cote de Liesse Rd., Montreal 760, Quebec.

Check No. 31 on Reader Service Card

harman / kardon
The Music Company

Capacitor Symbols

Various symbols are used in schematic diagrams for fixed, single variable, ganged variable, and electrolytic capacitors. The basic symbol is a pair of lines, one of which is slightly curved, although you will find some capacitor symbols using a pair of straight, parallel lines. The variable capacitor is identified by an arrowhead placed on one of the lines while a ganged variable is represented by a dashed line to indicate simultaneous operation of both rotors of the ganged unit. The symbol for an electrolytic is often marked with a plus sign to indicate that this unit is polarized.

Other information may or may not be marked alongside the capacitor symbol. Sometimes the amount of capacitance is marked adjacent to the capacitor symbol, but it is necessary to understand whether this number represents microfarads or picofarads. Quite often this information is not supplied, since it is expected that the person reading the diagram will have sufficient circuit knowledge to know what value of capacitance is intended. As a general rule, capacitance values on circuit diagrams are understood to be in microfarads. The number .01 adjacent to a capacitor would indicate .01 microfarads. However, capacitance values in picofarads would be marked

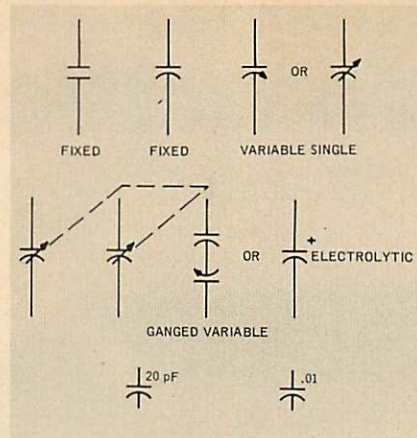

Fig. 12—Capacitor symbols.

as such. Thus, 20 pf means 20 picofarads.

Increasing and Decreasing Capacitance

Capacitors may work alone or in combination with other capacitors, depending on circuit requirements. When two capacitors are placed in shunt, or parallel (Fig. 13-A), the total overall capacitance is increased and is equal to the sum of the individual capacitances. Generally, only capacitors having identical d.c. working voltage ratings are connected in this way. However, this restriction does not apply to

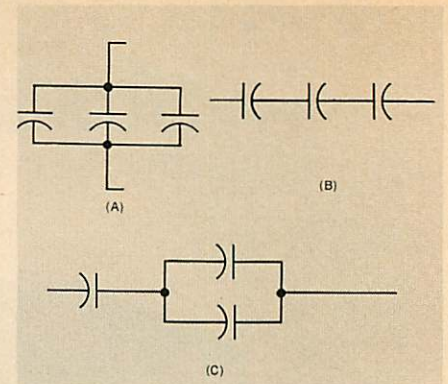

Fig. 13—Capacitors can be connected in parallel (A), in series (B), or in series-parallel (C).

capacitance, for a unit having a large capacitance may be parallel-teamed with one having a miniscule amount.

Capacitors can also be wired in series, but this reduces the overall capacitance (Fig. 13-B). This method is sometimes used to reduce electron-storage capacity in a particular circuit or to increase the d.c. working voltage. The d.c. working voltage of the series connection is equal to the sum of the d.c. working voltages of the individual capacitors. Sometimes series-parallel combinations are used to supply both a higher working voltage and a higher capacitance.

Capacitors and Resistors

Paraphrasing John Donne, no capacitor is a component unto itself. They are quite often used in combination with other electronic parts, such as resistors. A resistor in series with a capacitor will slow the rate at which electrons pour into a capacitor plate. Sometimes, in an electronic circuit, it will be necessary for a capacitor to charge, or to discharge, within a set time limit. Resistors are also placed in shunt with capacitors in some cases to discharge the capacitors within a specific time after they have been charged.

Jobs Capacitors Can Do

Like resistors, capacitors have a variety of interesting jobs to handle in hi-fi equipment. They can be used to separate currents of different frequencies. They can be used to deny the passage of some currents and to permit the flow of others. They can be used to smooth currents when these currents contain unwanted variations. And, of course, you use them every time you turn on your tuner or receiver to select a station.

(To be continued)

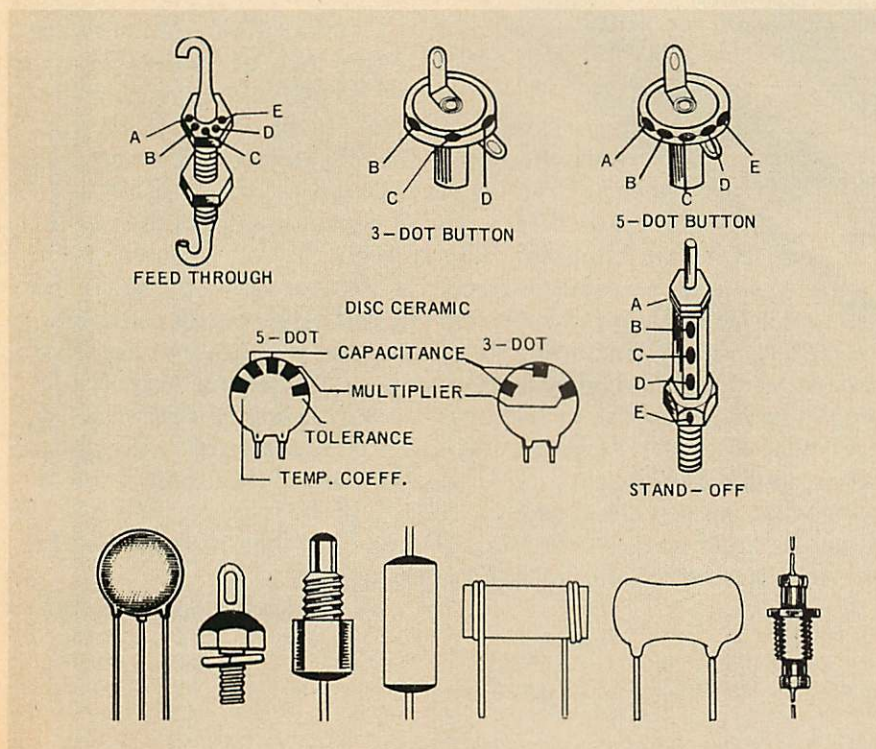

Fig. 11—Capacitors are available in a tremendous variety of sizes, shapes and styles. The letters adjacent to the capacitors indicate color-coded dots which supply data.

A New Concept in Diamond Styli

Dr. Hedi Benz*

WITH TODAY'S high quality phono cartridges, reduction of mass is a prime consideration for the design engineer. Although mass of the stylus has been whittled down to a low of 0.9 mgm, further reduction still appears to be desirable. Additional decreases in the mass of the cantilever and needle assembly would result in decreased record wear, greater trackability, extended frequency response, and higher peak velocity for

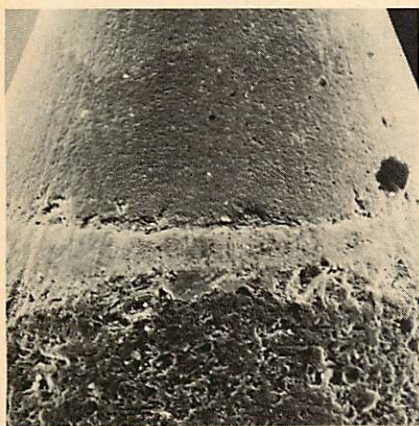

Fig. 1—The gold-nickel-base bond is clearly visible between the diamond tip at the top and the sapphire shank below. (416X magnification, scanning electron micrograph.)

the handling of heavily modulated musical passages.

On one hand we have the bonded stylus with a diamond grain bonded to a steel or molybdenum shank. The main advantage of this type is the relative ease of manufacture, which results in a low price. Their disadvantage is a relatively high mass due principally to the high specific gravity

*Benz Mikrodiamanten Co., Andelfingen, Switzerland.

of the shank material. The only way to further reduce the mass of a stylus of this type is to reduce its physical dimensions. Usual dimensions for a stylus of this type is 0.012 in. for the diameter of the small end and a length of 0.030 in. Even with these dimensions, handling and assembling are quite a problem, one which obviously becomes greater if the dimensions are reduced.

On the other hand is a stylus made of solid diamond, one which is carefully polished like a gem diamond. A limited demand exists for this type because of the "quality regardless of cost" approach. Since the specific gravity of diamond is 3.9, the mass of this type of stylus is only half that of a conventional stylus. Unfortunately mass production of such styli is extremely difficult since uniform diameter and length cannot be maintained. Selection of styli into groups with the same diameter and length is necessary in order to match them with their corresponding assemblies. This consequently increases their ultimate price.

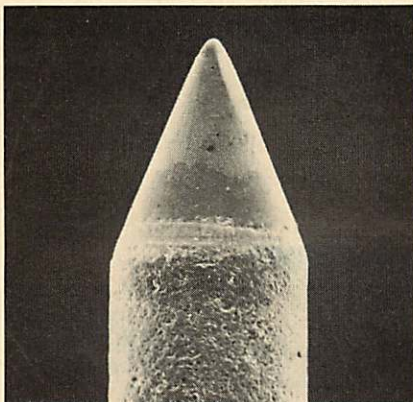

Fig. 2—The differing textures of the sapphire shank and diamond tip are clearly apparent. (144X magnification, scanning electron micrograph.)

The Benz Mikrodiamanten Co., of Switzerland has developed an entirely new stylus, combining the advantages of both types of styli, and has applied for patent. A new bonding method allows a diamond to be bonded to an aluminum oxide (Al_2O_3) sapphire shank. The bond itself is superior in strength to the aluminum oxide shank material.



Fig. 3—The diamond tips are bonded to the sapphire shanks in this controlled atmosphere furnace.

The new stylus offers a number of advantages. Only the tip, the actual working section, is made of diamond, resulting in a large savings in costs. The shank is made of aluminum oxide, with its inherent advantages of relative ease of manufacture and low mass. Holding accurate diameter and length is no problem. In consequence, this facilitates the mounting of the tip into the stylus assembly. Styli made with this method, having a 0.010 in. diameter and 0.030 in. length, have the extremely low mass of 0.11 mgm. One further advantage of these styli is their corrosion resistance since only gemstones and noble metals are used in manufacture.

A Practical High-Frequency Trackability Test For Phono Pick-Ups

C. R. Anderson* and P. W. Jenrick*

AFTER THE EVOLUTION of almost a century, phono pick-ups have now reached a high standard of performance but two conflicting requirements are still limiting factors. What *are* these requirements? First, the stylus tip must remain in firm contact with the groove wall, and secondly, the force used must be low enough to reduce record wear. There are two frequency ranges involved—low frequencies where the mechanical compliance of the moving system limits the groove amplitude that can be traced and at high frequencies where tracing distortion and reflected mechanical impedance of the moving system both limit groove acceleration. Tracing distortion has long been considered a serious problem, but in the last five years or so pick-ups have been developed with vastly improved tracking abilities¹.

Severe high frequency transients occur quite often in musical material. Sounds of bells, harpsichords, cymbals, and even human voice sibilants contain a high frequency overtone structure that establishes the character of the sound. Figure 1 shows oscillograms of material taken from commercial records with a 10,000 Hz 5 cm/sec test band for comparison. It can be seen that the transients are of short duration and the signals are

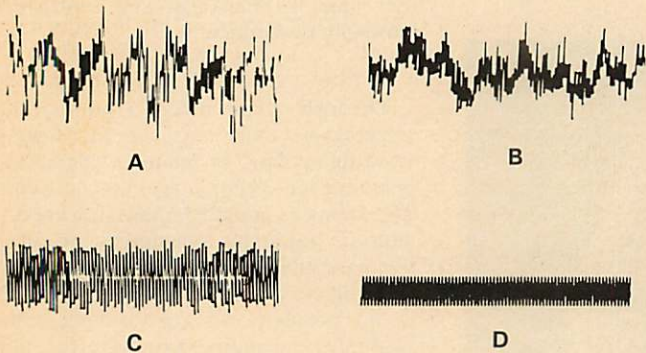

Fig. 1—Samples of instrumental waveforms: A, chimes; B, harpsichord, and C, orchestral bell. D is an STR 100 test signal, 10 kHz at 5 cm/sec peak.

highly complex. When a phono cartridge mistracks such material, the sound becomes “rough,” “harsh,” and “shattered.” The character of the sound is degraded by the introduction of low and mid-frequency noise. This is shown quite clearly in Fig. 2, which is a one-third octave analysis of an orchestral bell note. The fundamental pitch is 1800 Hz and the third and fifth harmonics are seen at 5400 and 9000 Hz respectively. The dotted lines show what happens when mistracking is induced by reducing the stylus force. The harmonic structure is still unchanged but the bell is almost drowned in a sea of noise!

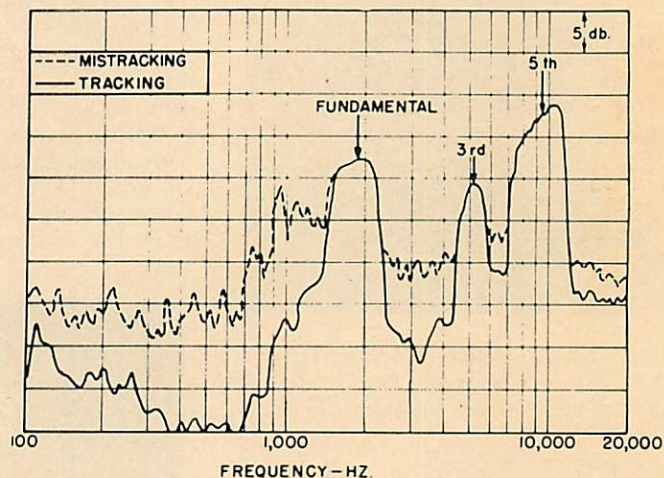

Fig. 2—One-third octave analysis of orchestral bell note.

How are pick-ups tested or evaluated in their performance on complex signals containing transient peaks? Present methods include harmonic distortion measurements, IM tests using the CCIF standard, and listening tests using various recorded sounds. All of these are open to objections: THD measurements are affected by the harmonic structure extending past the high frequency pass-band of the system and it is not that easy to record high level signals for the long periods necessary. The CCIF IM test uses two high frequencies of equal amplitude and detects the difference frequency. It has the advantages

*Shure Bros., Inc., Evanston, Illinois. From a paper presented at the 41st AES convention.

that the spurious products appear within the pass-band and the ratio of peak-to-average signal is lower than the THD method, but it is still difficult to make such IM test records. Finally, subjective listening tests are useful enough for rough comparisons but are not really reliable for accurate measurement. So new methods were sought which would give meaningful evaluations. One solution is the use of a repetitive transient signal—in other words, a modified tone burst. Figure 3 shows the basic arrangement. The signal from the oscillator is passed through a synchronous tone-burst generator which switches at the zero crossing of the sine wave, passing 8 cycles and blocking 32 alternately. Figure 4 shows the output signal at X and it can be seen that it is rich in harmonics of the

repetition rate, which is 1/40th of the oscillator frequency, F_0 . When this signal is passed through the one-third octave filter centered on F_0 , most of the low frequency components are removed giving the results shown in Fig. 5. The signal has a 25 per cent duty cycle so it can be recorded at high peak levels without difficulty. This recorded signal can now be used to evaluate pick-up distortion in several ways: 1. By listening to changes in the repetition rate component as signal intensity is changed; and 2. By observing the entire output or the repetition rate component on a 'scope, and 3. Analyzing by filter or spectrum analyzer. Figure 6 shows what happens when the signal is so distorted that the positive and negative portions are unequal and the low frequency components reappear.

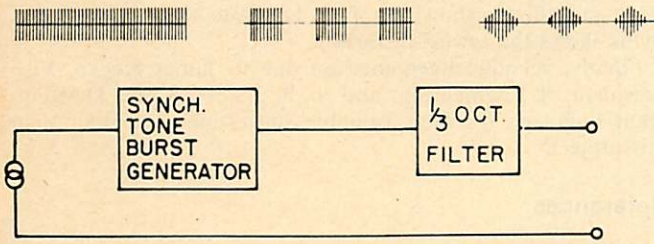

Fig. 3—Generation of test signal.

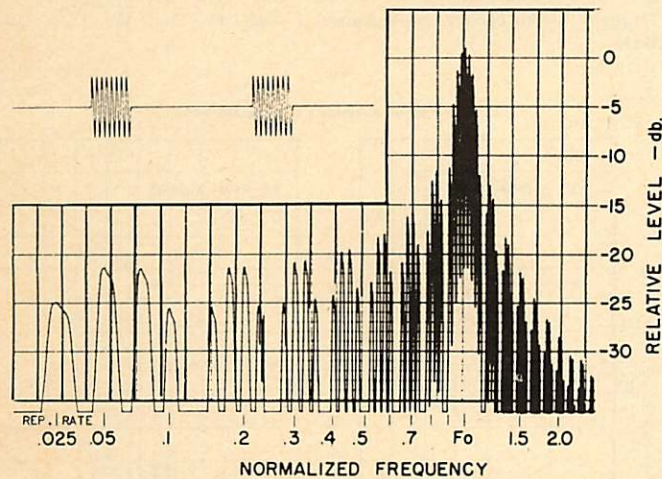

Fig. 4—Analysis of rectangular tone burst.

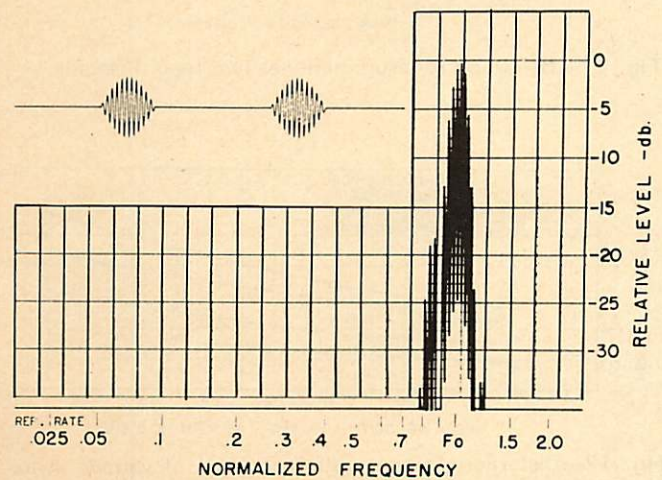

Fig. 5—Analysis of filtered tone burst (test signal).

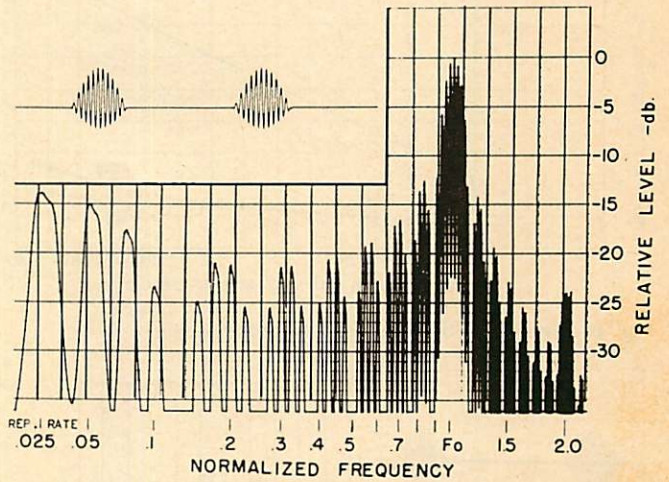

Fig. 6—Analysis of distorted test signal.



Fig. 7—Pictorial analysis of distorted test signal.

Figure 7 is a pictorial analysis of a distorted test signal which can be separated into an undistorted signal A to which is added a bump B which appears at the repetition rate. This bump has the fundamental frequency of the repetition rate plus a series of harmonics. The test signal and high frequency transients met with in recorded music both react in the same way when distorted. Both produce strong in-band frequency components which are readily detected. But, of course, the test signal is well defined and repeatable. The greatest significance of the test signal is derived by analyzing the spectral components. The low frequency components appear at the repetition rate since the pick-up only mistracks near the maximum velocity of the transient. This "repetition rate distortion" is a reliable index and it can be defined as follows:

$$D_{rr} = \frac{V_{rr}}{V_{F_0}} \times 100\%$$

Where

D_{rr} = repetition rate distortion in per cent,

V_{rr} = voltage at repetition rate ($F_0/40$) as measured using a wave analyzer with a 3 db bandwidth of 30 kHz, and

V_{F_0} = voltage at oscillator frequency F_0 measured using a wave analyzer with a 3 db bandwidth of 1 kHz.

If this distortion figure is plotted against modulation velocity for a constant tracking force, the mistracking point of a pick-

up can be easily determined. Figure 8 shows a distortion plot made with a 10.8 kHz tone burst recorded at four velocity levels. Each of the three curves represents the distortion measurements of the pick-up over the available velocity range for a given tracking force. At point A the pick-up is maintaining good contact with the record groove, and the low distortion is partly residual and partly due to a little tracing distortion which is modified by indentation. At point B, the pick-up is just beginning to mistrack and this instable condition fluctuates with small warps and other defects in the record

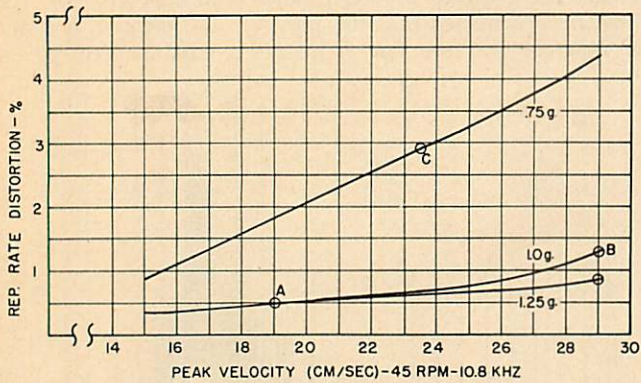

Fig. 8—Shure V-15 II distortion characteristic.

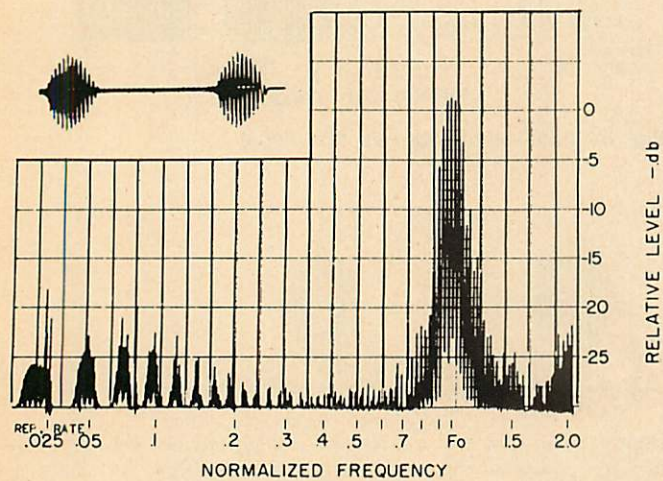

Fig. 9—Analysis of marginal tracking pick-up signal.

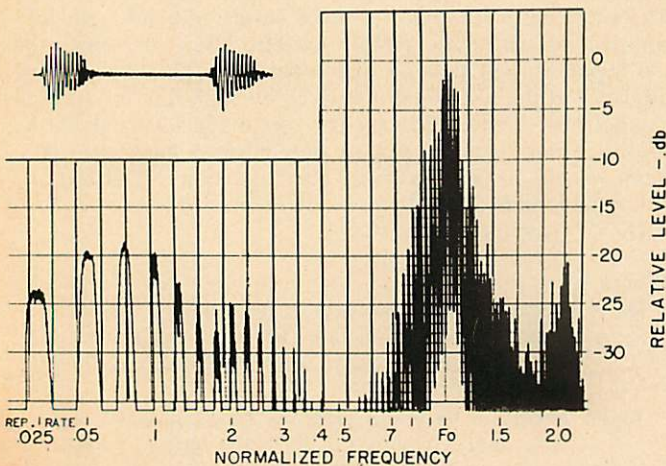

Fig. 10—Analysis of mistracking pick-up signal.

and so on. The spectral analysis is shown in Fig. 9 where the low frequency components are seen. Compare this with Fig. 5. At point C, the pick-up is mistracking quite severely and the distortion has increased to 3 per cent.

One useful feature of this test record is the fact that it can be played at a high speed to increase peak velocities. For instance, a velocity of 11 to 22 cm/sec at 33 1/3 rpm increases to 15 to 30 cm/sec at 45 rpm. The frequency also increases with the same ratio, making the test even more severe. Typical results are shown in Fig. 11, where two cartridges, the Shure M55E and the V-15 II, are compared at different peak velocities. The M-55E shows a tracking stylus forces, the MSSW reaches a tracking threshold of 14 cm/sec at 8 kHz, while the V-15 II does not begin to mistrack until nearly 30 cm/sec at 1.8 kHz is reached.

The test signal can also evaluate distortion caused by stylus wear and this is shown in Fig. 12. Note that the bi-radial stylus shows the lowest distortion.

Finally, acknowledgements are due to James Kogen, Vice President of Engineering, and to B. Jakobs, Chief Development Engineer, for their valuable suggestions and interest in this project.

References

1. C. R. Anderson, J. H. Kogen, and R. S. Samson, "Optimizing the Dynamic Characteristics of a Phonograph Pick-up," *J. Audio Eng. Soc.*, Vol. 14, p. 145, 1966.
2. J. G. Woodward and R. E. Werner, "High Frequency Intermodulation Testing of Stereo Phonograph Pick-ups," *J. Audio Eng. Soc.*, Vol. 15, p. 130, 1967.

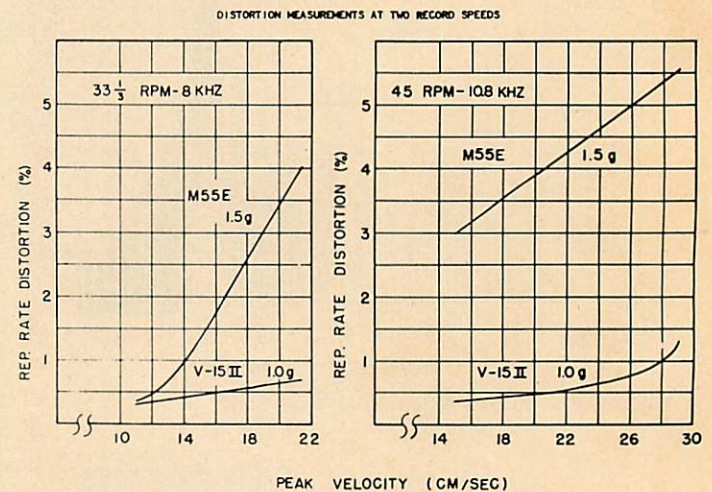

Fig. 11—Distortion measurements at two record speeds.

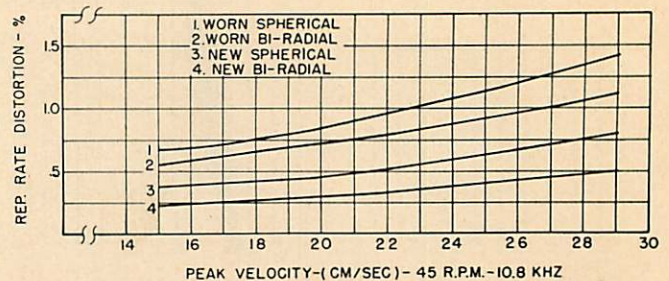
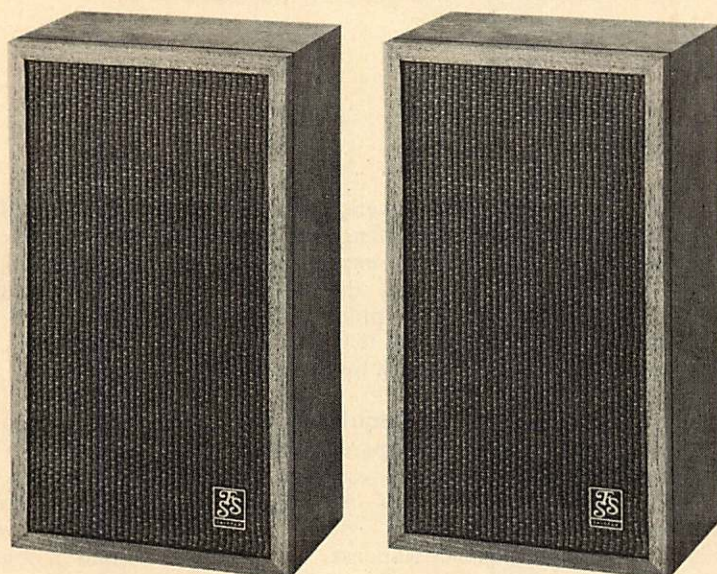

Fig. 12—Distortion characteristic (tracking) of various stylus radii.

We're giving away 100 pairs of Fairfax Speakers if you're willing to listen



it pays to listen

One Hundred Lucky Winners will receive
this pair of FAIRFAX FX-100A Speakers
List Price \$159.90 per pair.

If you're willing to listen we know we can convince you that dollar for dollar, model for model, you get more high-fidelity performance with *Supersound* by Fairfax.

In fact, we're giving away about \$16,000 worth of speakers to audio enthusiasts who visit their Fairfax Dealer for a *Sound Comparison*. Listen to any Fairfax System from our compact, inexpensive bookshelf model to our incredible 12 speaker (4-way system) *Wall of Sound*. Ask your dealer to match

them against competitive speakers. Then fill out a *Fairfax Entry Card*. You can be one of the 100 lucky winners of a pair of supersounding Fairfax FX-100A Speakers.

These 2-way, 2-speaker systems feature a heavy duty 8" bass driver, a special 3" tweeter, tube ducted port design, and superior performance with no distortion, no coloration, true pitch with zero overlap and tonal balance.

FAIRFAX SUPERSOUND . . . a new
definition of the listening
experience.
INDUSTRIES INC. 900 Passaic Ave., East Newark, N.J. 07029

Offer ends October 31, 1972 and is applicable only in states where not prohibited. Winning entrants will be notified by their dealer. If winning entrant has already purchased any Fairfax Speaker during this demonstration offer he will receive a refund from his dealer up to the value of the FX-100A.

Check No. 37 on Reader Service Card

How we test a Phono Cartridge

TELLING READERS how we evaluate various elements of high fidelity component equipment appears to be on the road to becoming a series—and after enough articles in the series, everyone will be just as able to test equipment as, presumably, we are. In June, we described the steps followed in making PROFILE tests on turntables, and a year and a half ago we described testing methods employed with stereo headphones. Now it's cartridges which are to come under our scrutiny.

As has often been said before, over the years, we do not print a PROFILE on a piece of equipment which, in our opinion, does not come up to the standards we feel should be met for high fidelity equipment, or at least, one which does not come up to the manufacturer's specifications. It has long been our policy to pass the information on to the manufacturer in the hope that he may agree with us that the particular item tested was in some way faulty and will substitute another unit which does meet specifications. If a second or third unit fails in the same tests, the item is returned and publication of the profile is cancelled.

In case readers should think that the absence of a particular manufacturer's products might indicate that we do not think they are worthy, let us clear up that misapprehension for once and all. Some manufacturers do not feel that profiles are of any value to them, and equipment is not offered for testing.

This we cannot prevent, although often we do request an item, and it may or may not be sent, depending on the manufacturer. But the absence of profiles on any product does not necessarily indicate that it is not considered good enough for these pages.

Cartridge Test Requirements

The important parameters of the performance of a cartridge are, in probable order of importance, the following:

1. Frequency response,
2. Separation,
3. Signal output,
4. Tracking ability,
5. Intermodulation distortion,
6. Stylus-force requirements, and
7. Effect of lead capacitance.

Of these, the easiest to measure is frequency response. This may be done in a number of ways, and many years ago it meant measuring the output of the cartridge at 20 or 30 discrete frequencies as reproduced from a typical test record—for example, CBS STR-100. Because of the time required to make such a series of measurements, and the possibility of some disturbance originating anywhere between the frequencies available on the test record, the writer developed a device which would provide a continuous graph of frequency response from a sweep record and which was modest enough in cost for our budget. Originally this was done using the same CBS STR-100 test record, but this particular source had

some disadvantages. First, it covered the range only from 40 to 20,000 Hz, and second, the recording characteristic was a straight line from 40 to 500 Hz, at a 6-dB-per-octave slope (constant amplitude), and another straight line from 500 to 20,000 Hz (constant velocity). There is nothing wrong with that approach, providing the corrective network is the complement of that curve. But such a complement cannot be produced readily using RC networks, which are almost universally used in component equipment. Nor, of course, does this characteristic conform to the RIAA equalization.

A little search, however, turned up another test record, Brüel and Kjaer QR-2009, which covered the range from 20 to 20,000 Hz, and which did conform to the RIAA curve from 20 to 1000 Hz, and flat above that point, thus making it possible to produce a graph of the response of a cartridge with a simple and conventional RC equalization network. Consequently, the graphic recorder was redesigned to accommodate the curve of the QR-2009 record.

So, using the graphic recorder, the frequency response of the cartridge is first recorded over the range from 20 to 20,000 Hz, first with the left channel of the cartridge and then with the right. Then the separation curves are made, with the left channel playing the right-channel recording, and again with the right channel playing the left-channel band. The record also provides

a lateral band and a vertical one for a considerable flexibility in testing requirements.

Now, having the frequency response curves, we observe them carefully to determine if there are any peaks in the response. Actually there are often some such peaks, so further graphs are made—on both channels—with additional capacitance across the leads. The normal capacitance of typical turntable leads is of the order of 250 pF, and we add increments of 50 pF across the leads and make further series of curves which show the effect of added capacitance.

We have previously remarked on the importance of reading the instructions which accompany any electronic equipment. It is of no less importance with cartridges, for the manufacturer is likely to suggest the optimum capacitance into which the cartridge should work. Even if he doesn't, however, we find it out for ourselves. If it is found that a flatter response is obtained with a specific value of capacitance, we so indicate, and all further testing is done with the value in the circuit.

In addition to reducing possible peaks, the proper value of load capacitance also helps to remove the "swayback" that often occurs in the range from 5000 to 8000 Hz.

The next step in testing a cartridge is the photographing of its square-wave response. Another CBS record—STR-111—is pressed into service for the next two operations. The 1000-Hz square-wave band is played through a flat preamplifier—one without either low- or high-frequency equalization—with a gain of 40 dB—and the output applied to a scope. Right, left, lateral, and vertical bands are also available on this record for various tests, but we normally use only the left channel for this step. The display on the scope screen is photographed, using a 105-mm lens on a 35-mm camera. This usually requires an exposure of 1/15 of a second at f/4.0 with Panatomic X film—and to identify the film at any later date, a card is placed at the side of the screen with the name and model number of the cartridge written on it with a felt-tipped pen.

Distortion Measurement

The same CBS STR-111 test record is used to make measurements of intermodulation distortion. This record has a number of IM test bands at different levels and with different frequency combinations, and in lateral and vertical modes also. These combinations are: lateral, 400/4000 Hz at levels of +6, +9, +12, +15, and

+18 dB; lateral 200/4000 at the same five levels; vertical 400/4000 at +6, +9, and +12 dB, and vertical 200/4000 at the same three levels. While we make and record distortions at all 16 conditions, we chose only two to list in profiles—lateral +9, and vertical +6, both at 200/4000 Hz. These seem to be indicative of overall performance.

Returning to the use of the STR-100 record, we measure the output for a stylus velocity of 3.54 cm/sec in the left-channel mode and then in the right-channel to compare outputs between the two channels. Next we go through the various steps of levels recorded on the STR-100 record, watching the scope for any evidence of mistracking at the normal (manufacturer-specified) stylus force. We then reduce tracking force 1/4-gram at a time and observe the results.

Note that the order in which the measurements are made do not coincide with the importance we assigned them earlier. Our order of making the various steps was simply the result of minimizing the changing of leads and equipment, as well as the records themselves. Intermodulation measurements are made on an EICO 902 Harmonic and IM Distortion Analyzer. The "flat" preamplifier used for taking the photos of the square-wave response is the one used in the description of "Testing Turntables" as described in the June issue.

For many years we have been using a turntable never sold in this country—the PE Studio 33, which we acquired in Germany during a visit there in 1964. It has apparently gotten "tired," so we have substituted a Thorens 150 with a Rabco SL-8 arm, and the results are somewhat more consistent.

Frequency-response curves are recorded on the new Justi-Meter III, the latest model of the original graphic recorder designed by the writer some three years ago. Since the magazine provides its own form of graph paper to ensure consistency in appearance, we replot the machine-run curves on the forms used in these pages, using a light blue pencil. The drafting department retraces the curves in black and adds any necessary legends to the forms before including them in the made-up pages for the magazine.

The write-up of the observations, together with a listing of the manufacturer's specifications which precede all our profiles, is finally prepared, with the last few paragraphs devoted to a subjective evaluation of the performance of the cartridge on a number of records with music on them—as contrasted to all the measurements

which are made with no music whatever, nor with any listening, just viewing on the scope screen in some instances, and reading meters and making runs on the sweep record.

To the purist, the listing of the qualifications of a cartridge are of some importance in his selection. To the music lover—the kind who has no technical interest in equipment whatever—the subjective aspect is the more important. It has been our experience, in most instances, that the cartridge that measures well also sounds the best, even though we have long subscribed to an axiom of the late C. J. LeBel that "If it measures good and sounds bad, it *is* bad."

Measurements of inductance and d.c. resistance are usually made somewhere along the line. If these values fall within the usual range for the particular type of pickup, they are seldom mentioned—it is only when one model deviates appreciably from the norm for cartridges of its type that it is mentioned at all. About the only effect of inductance differing from the usual could be a variation in the equalization, *provided* the equalization were of the passive type ahead of the preamplifier—practically a rarity in consumer equipment. A low d.c. resistance *might* improve the noise figure of the first transistor amplifier stage—again an unlikely difference in consumer amplifiers and receivers. Regardless of their intrinsic inductance or resistance, most cartridges are designed *to work into* an impedance of 47,000 ohms, and this value is standardized in most equipment. Some high-quality items offer an extra pre-preamp stage into which may be fed low-impedance cartridges, such as the moving coil types.

It is possible that a lower inductance could possibly reduce pick-up from external sources, but this again is unlikely. Practically every good pickup on the market is sufficiently well shielded against hum fields.

As with practically all components in a high fidelity system, the final selection should be made on the basis of how it sounds to the buyer. No two speaker systems sound exactly alike, nor do any two cartridges. Nor, for that matter, do any other two components. You end up by choosing the one which sounds best to you, preferably in your system at your own home with your own two (or four) speakers. But a thorough perusal of the actual measurements may give you a hint as to the ones you should compare before you buy the one of your choice.

C. G. McProud

Phono Cartridge Q's and A's

Mainly For Beginners

Q. How much channel separation is really necessary for stereo pick-ups? I have seen glowing reviews of certain pick-ups which had little if any separation above 10 kHz.

A. Separation should not be less than 15 dB at mid-frequencies, falling at each end of the band as shown in Fig. 1. Any improvement above say 20 dB at 1 kHz and 10 dB at 12 kHz would be difficult to hear!

Q. What is meant by "tracing distortion?"

A. This is the distortion caused by the fact that the recording cutter head is sharp, chisel-shaped, and the reproducing stylus is round or spherical. Obviously, it cannot be chisel-shaped or it would tear up the record! Figure 2 shows how the stylus path is distorted by the shape of the groove wall. Even if the stylus was small enough to fit into the bottom of the groove at B, it would still not follow the groove precisely. Tracing distortion is not normally significant except at high recording velocities or near the record center, where the groove curvature increases (see Fig. 3).

Q. Is an elliptical stylus better than a conical?

A. It all depends. . . . An elliptical or, more correctly, a *bi-radial* stylus is certainly nearer the shape of the cutter than a conical type but tracking force has to be less and the increased mass of a bi-radial could even nullify any gains! It goes without saying that bi-radial styli must be very carefully made and polished or increased record wear will occur. Bi-radial styli are made in sizes from 0.7 to 0.9 mils in the large dimension and 0.2 to 0.4 mils in the smaller. In practice, a lot depends on the record itself—whether Dynagroove or some other kind of groove compensation is used—and the particular cartridge and tonearm. Some time ago, ADC released a cartridge with three styli—a conical and two bi-radials. A quick check with four users was very interesting—two said they left the conical stylus in, two stayed with the medium bi-radial. All four said the differences between styli were quite small.

Q. Does a pick-up have to be matched to an amplifier?

A. Yes, within certain limits. For-

tunately, most amplifiers now use a standard input resistance of 47 K which matches the great majority of cartridges. The capacity of the screened input leads can adversely affect the matching by rolling-off the high frequencies. Figure 4 shows the effect of different capacitances on a typical phono cartridge (ADC XLM).

Q. What does skating force mean?

A. Skating force can be defined as the force that draws the tonearm towards the center of the record. It is neutral-

ized in top quality tone arms by the use of tiny suspended weights or a magnetic counterforce. In the days when the effects of skating force were greatly exaggerated, many enthusiasts used to tilt the motorboards to give a compensating bias.

Q. What is a Shibata stylus?

A. This is a kind of bi-radial stylus specially developed by the Japanese Victor Company for use with their discrete four-channel records. As can be seen in Fig. 6, it makes better con-

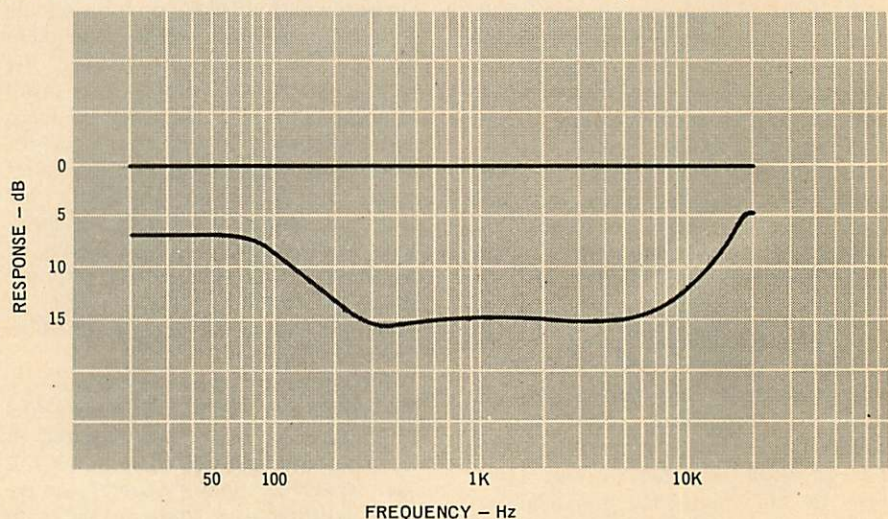

Fig. 1—Showing minimum separation for a good stereo image.

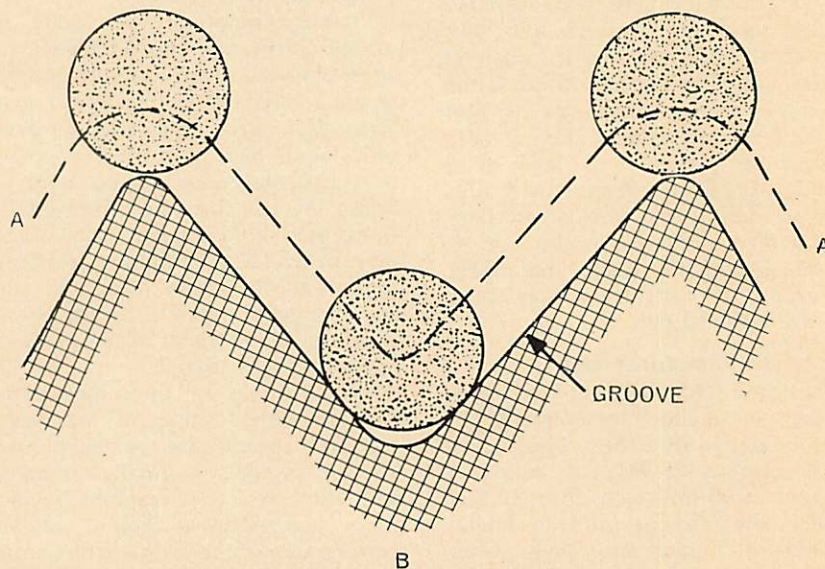

Fig. 2—How tracing distortion is caused. A-A is the stylus path.

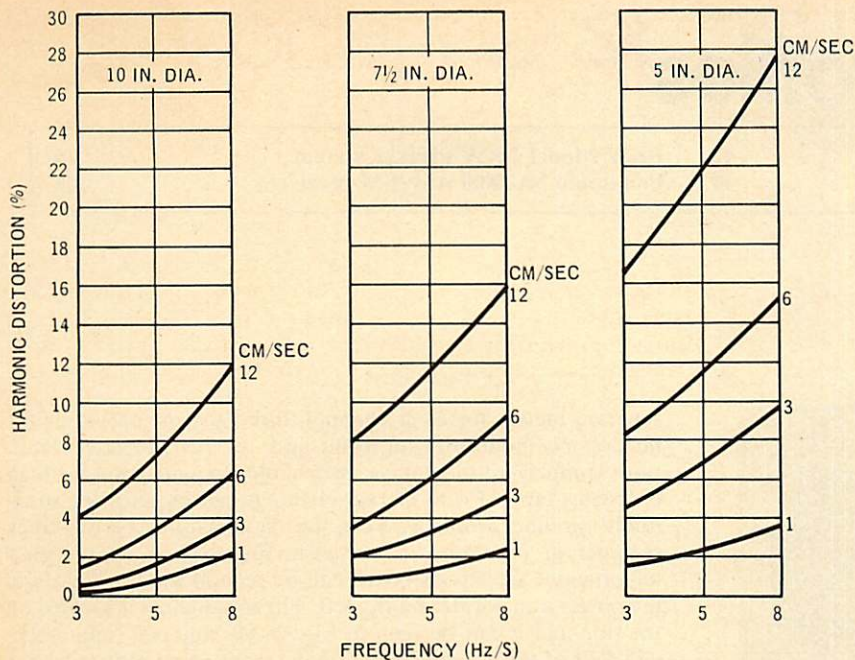

Fig. 3—Tracing distortion at different velocities, frequencies, and record diameters. Stylus size: 0.6 mils. (after M. S. Corrington, "Tracing Distortion in Phonograph Records," *RCA Review*, June, 1949.)

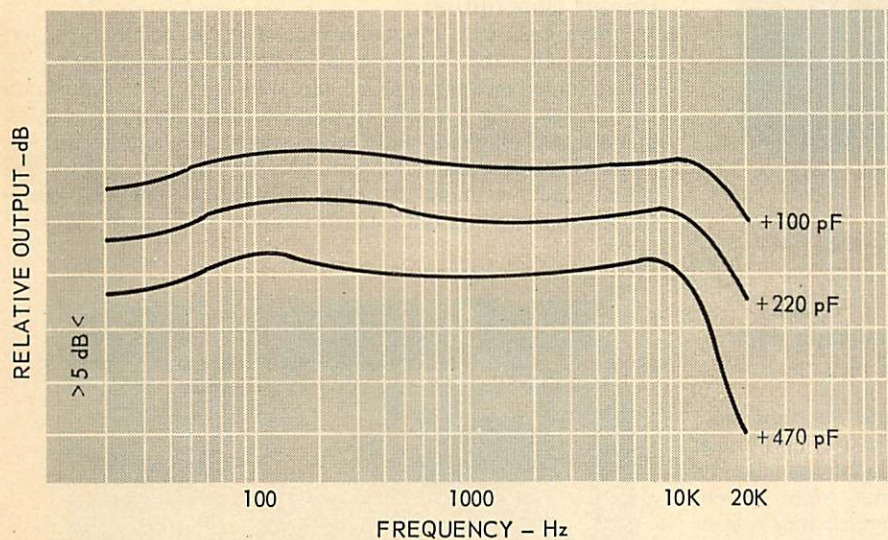

Fig. 4—Showing effect of lead capacity.

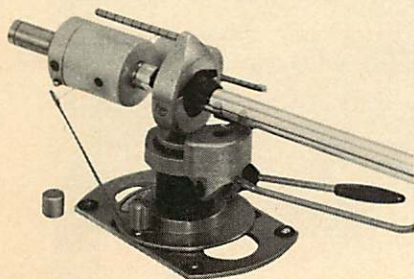

Fig. 5—Anti-skating device as used in the SME arm.

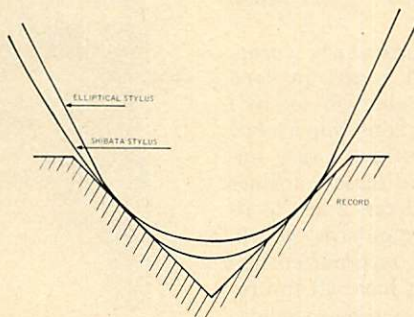
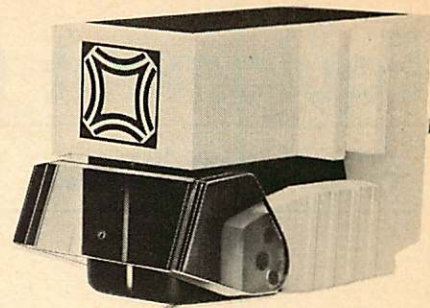

Fig. 6—Shibata stylus.



JVC 4MD-20X

tact with the record grooves and is capable of better high frequency response with lower tracing distortion. Naturally it can be used to advantage with ordinary stereo discs and we will see and hear more about the Shibata stylus in the near future. Only snag at the moment is the relatively high cost of manufacture.

Q. How is the output of a phono cartridge rated; in other words, what does 1.4 mV per cm/sec mean?

A. There is no standard rating method but the most commonly used measurement refers the output to a 1 kHz signal which is recorded at a velocity of 1 centimeter per second. Thus, a pick-up with a rated output of 1.4 cm/sec would produce an output of 7 millivolts from a 5 cm/sec signal (5×1.4) and 28 millivolts from a 20 cm/sec signal. Highest velocity normally recorded is about 30 cm/sec. The CBS standard test record has a 1 kHz signal recorded at 3.54 cm/sec—which means the output figure has to be divided by 3.54 to arrive at the 1 cm figure.

Q. What does compliance mean?

A. Compliance is the opposite of "stiffness" and can be defined as the distance of movement caused by a certain force acting against a spring or mechanical resistance. In phono cartridges, the distance is expressed in centimeters and the force is measured in dynes (1 dyne equals one-thousandth of a gram). The forces involved are microscopic so compliance is stated in millionths of a centimeter (10^{-6}) per dyne. Thus a typical stereo cartridge might have a compliance of 15×10^{-6} dynes/cm with a top quality model measuring 35×10^{-6} —which is near the upper limit. At one time it was thought that the higher the compliance figure, the better, but this particular numbers race soon came to an end when it was realized that other features, such as tip mass, were more important and a high compliance figure did not necessarily indicate a good pick-up. For this reason, plus the fact that the methods of measurement vary widely, compliance figures are rarely quoted these days.

Equipment Profiles

Sony TC-277-4 tape deck
Pioneer CS-E400 speaker system

42
44

B&W Model 70CA speaker system
Panasonic SA-5800 AM/FM receiver

46
48



Sony/Superscope TC-277-4 Quadradial tape deck

MANUFACTURER'S SPECIFICATIONS

Tape Speeds: 7½, 3¾, and 1⅞ ips. **Controls:** Four-channel/two-channel switch; tape direction, rewind, pause, and brake; four independent record level controls; headphone channel switch; bias and equalization switch; line-mic input switch, and front-rear record switch. **Inputs:** Four mics, four line or auxiliary. **Features:** Automatic shut-off, sound-with-sound, vertical and horizontal operation, automatic tape lifters, and record interlock. **Frequency Response** (Sony SLH-180 tape): 50 to 18,000 Hz ±3 dB at 7½ ips. **Dimensions:** 15¾ in. W by 7¾ in. H by 15½ in. D. **Weight:** 23 lbs., 2 oz. **Price:** \$339.95.

Quadraphonic tape recorders are not particularly cheap, partly because of the precision nature of the heads involved and partly because of the relatively low production—or so I would suppose. One exception is the new Sony-Superscope TC-277-4 which costs only \$339.95, and it offers a very impressive specification at that. I have had one of these machines in use for more than three months now and can attest to its ease of operation and high performance standards—which, incidentally, would be considered good in a recorder costing almost twice as much. Naturally, it does not have all the refinements of the big Quadradial 854-4S, for example (Syncro-Trak, 15 ips, variable speed control, etc.), but it *does* have

separate meters for each channel, three speeds, provision for headphone monitoring of front and / or rear channels, and, most important these days, switchable equalization for high efficiency tapes. Front or rear channels can be recorded separately—in other words, you can use the machine as a two-track recorder or for mono if you wish. Figure 1 shows the view underneath; the circuit board can be seen at the top right and the power transformer on the left. The input panel is located on the side and it can be seen in Fig. 2. Microphone input sockets—four of them—are located on the front panel just under the RECORD switches. Control functions can be seen from the photograph at the beginning of the review—the large knob on the right is the tape direction and rewind control. Fig. 3 shows the heads and capstan assembly.

Circuit Description

Figure 4 shows a block diagram of the basic circuit of one channel. The first stage uses a bootstrap arrangement to get a high impedance input (R₁, 2 and 3) in Fig. 5. The inductance L₁ is a bias trap. Four more transistors are used in the combined audio playback and record stages plus another for the meter. The erase oscillator uses two transistors in a push-pull circuit, and two more are employed in the stabilized power supply, making a grand total of 29, plus 11 diodes.

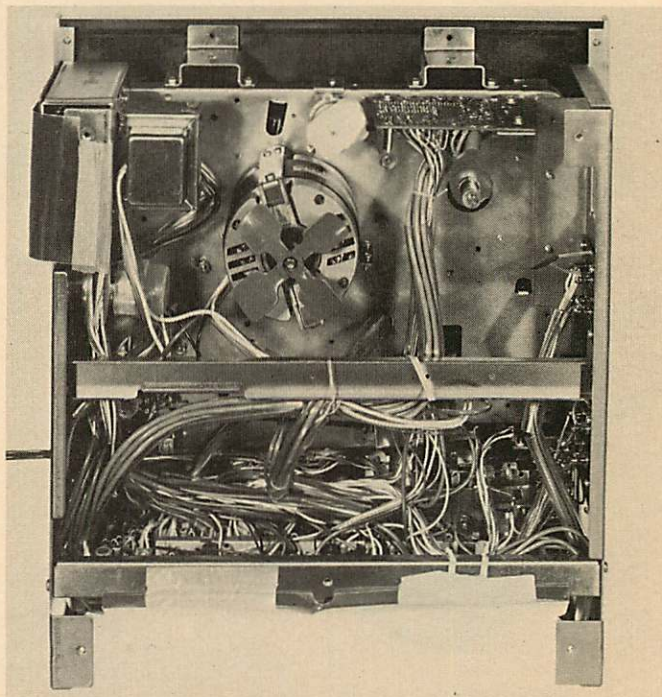

Fig. 1—View from beneath.

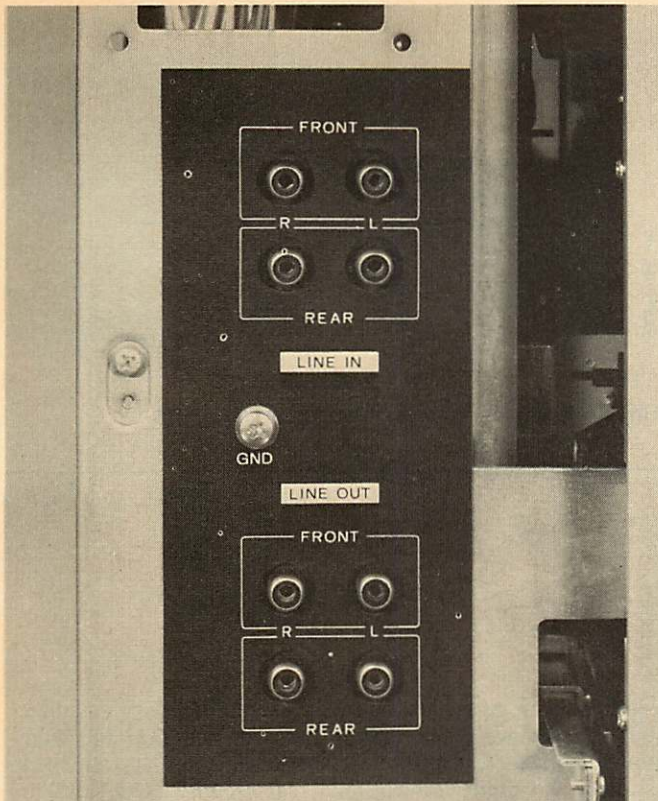

Fig. 2—Input panel.

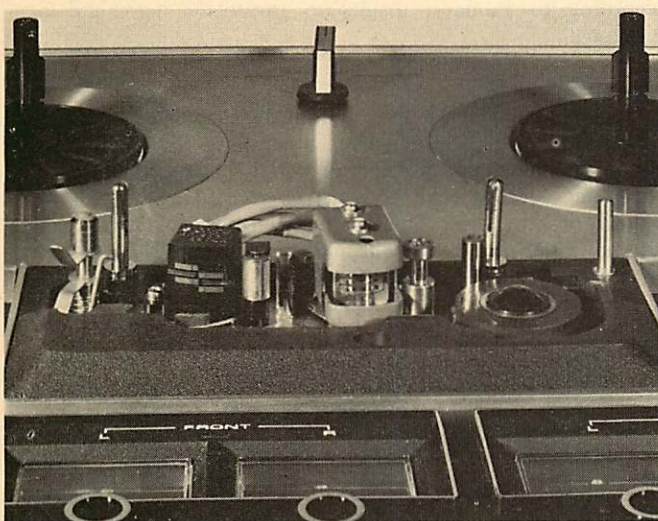

Fig. 3—Heads and capstan assembly.

Measurements

Frequency response at the three speeds (record-replay) is shown in Fig. 6. The tape used was Sony SLH-180 as recommended. Figure 7 shows the response at 7½ ips using standard Ampex test tape. Signal/noise was -62 dB at 7½ ips, -58 dB at 3¾ ips, falling to -54 dB at 1⅞ ips, all measured at +3 dB level. Distortion was 0.58 per cent THD for 0 dB, increasing to 0.75 per cent at +3 dB (at 7½ ips), and crosstalk at 1 kHz was -58 dB, increasing to -52 dB at 10 kHz. Sensitivity at the tape input sockets was 42 mV for +3 dB recording level. Line output was 0.775 volts at 0 dB.

Wow and flutter measured 0.13 per cent at 7½ ips, 0.16 per cent at 3¾ ips, and 0.25 per cent at 1⅞ ips. Tape rewind speed clocked at 3 min., 10 sec. for an 1800-ft. reel.

During the tests, several ordinary tapes were checked with the bias control set to "normal" and although results were good, there was no doubt of the superiority of such high density tapes as the BASF LP 65, Maxell HD 35, TDK 150 SD, and the Sony SLH-180. The saturation point of high fre-

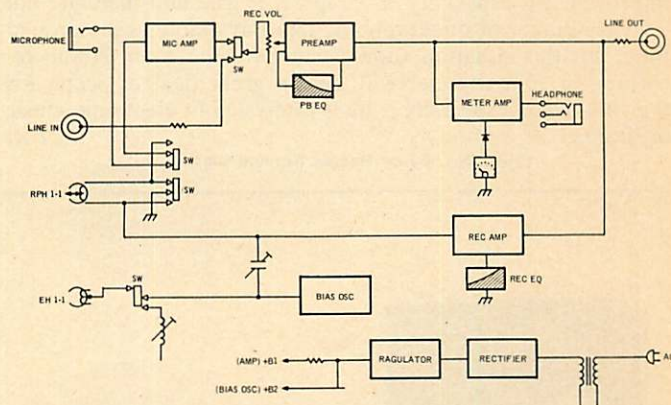

Fig. 4—Block diagram of the basic circuit, one channel.

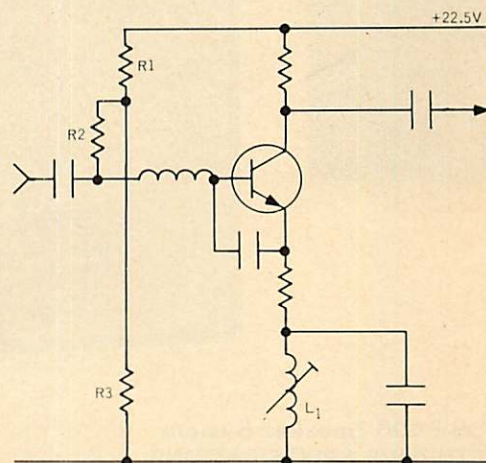

Fig. 5—Input stage.

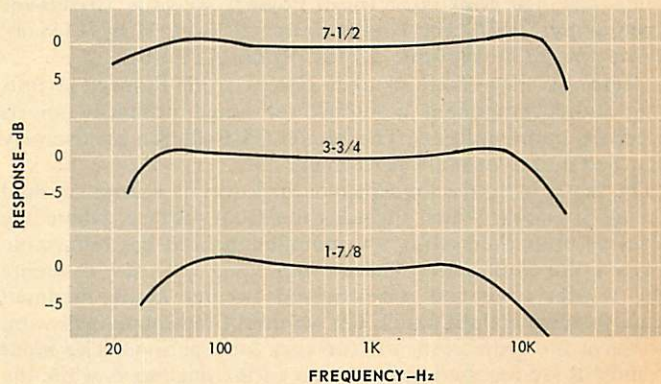

Fig. 6—Record-playback response at three speeds.

quencies is much higher, and there is an improvement in signal/noise of some 3 dB and the upper range is extended.

Mechanically, the TC-277-4 was quiet and well-behaved. I was particularly impressed with the tape direction control. The reels could be stopped without any fuss or overspill. Not only that, but the control was gentle enough to avoid the possibility of breaking tapes yet it was absolutely positive. Full marks to Superscope engineers. Electrically, the figures speak for themselves. It is sufficient to say that you would have to spend a great deal more money to get a significant improvement—especially at 7½ ips. It is true that there are not a great number of quadraphonic tapes available at the present time, but this situation should change quite soon. Home recording in four-channel will give a great deal of scope for the enthusiast—especially if he is interested in electronic music or drama.

T.A.

Check No. 44 on Reader Service Card

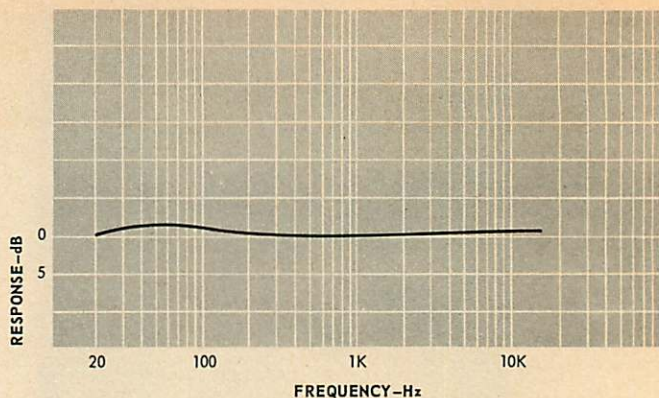

Fig. 7—Playback from standard tape at 7½ ips.



Pioneer CS-E400 Speaker System MANUFACTURER'S SPECIFICATIONS

System Type: Two-way, air-suspension. **Speaker Components:** Two; woofer, 8-in. cone type; tweeter, 1-in. dome type. **Nominal Input Impedance:** 8 ohms. **Frequency Response:** 35 to 20,000 Hz. **Sensitivity:** 89 dB/W at one meter distance. **Maximum Input Power:** 30 watts. **Crossover Frequency:** 2,800 Hz. **Dimensions:** 20⅞ in. H by 11½ in. W by 7½ in. D. **Weight:** 23 lbs. **Price:** \$79.95.

Here's a nifty small speaker system from Pioneer, a full-line audio component manufacturer noted primarily for its receivers and amplifiers. The Model CS-E400 is a handsomely finished and a versatile performer.

To begin with, the loudspeaker enclosure is walnut finished on all six sides, which includes the front surface, where the speaker units themselves are mounted behind the removable beige grille cloth panel. There's something very racy in seeing the woofer cone and wire-covered tweeter dome mounted on a finished walnut panel, but we doubt that many will want to leave the grille cloth off for very long periods. The input terminals are recessed into the rear of the enclosure, while the tweeter control is recessed into the front. With greater emphasis on the search for flatter frequency response in the

listening room, as evidenced by the increased use of equalizers and the like, we think that most users will find the front-mounted speaker adjustment controls are more convenient to use than the more conventional rear-mounted ones, and we hail this up-front location in the Model CS-E400.

This bookshelf-size speaker from Pioneer has a well-made conventional 8-in. acoustic suspension woofer. The 1-in. dome-type tweeter is made of especially treated wool fibers, which, according to Pioneer, results in improved high end performance.

Measurements

Our standard set of tests at four feet revealed the Model CS-E400 to be a good performer overall. It has low harmonic distortion, the major portion of which occurs in the second harmonic, coupled with above average efficiency as its most significant attributes. The frequency response curve of Fig. 1A shows the unit to be within ±6 dB from 40 to 14,000 Hz on axis and not significantly different off axis, as shown in

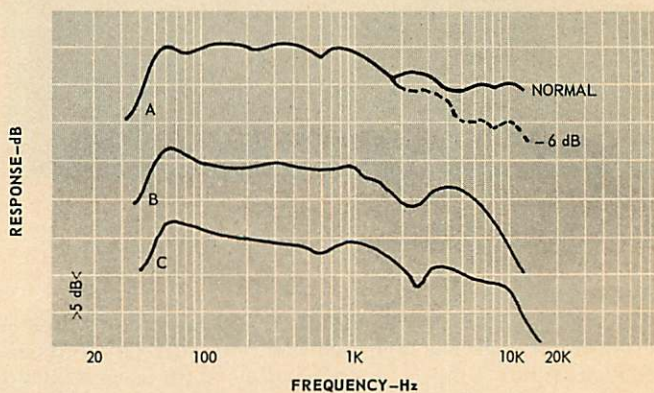

Fig. 1—Frequency response to ⅓-octave band pink noise. Curve A was measured from four feet, on axis. The upper treble-area curve is with "normal" tweeter setting; the lower with "-6 dB" setting. Curve B is response at 45° off-axis. Curve C is a composite of five curves, taken both on and off axis.

ENJOY THIS LOUNGER FOR TWO WEEKS FREE

"The Unwinding Center"

SPECIAL PRICE

\$89.50 (lounger)

34.50 (matching Ottoman)



Relax in 1001
different positions

SUPERIOR COMFORT CENTER

Look for these quality features

- Genuine Naugahyde Cover
- Foam filled comfort
- Chrome steel, rugged frame
- Gentle tilting action
- Big size (24" wide x 42" high)
- Sturdy matching ottoman
- It swings . . . It Tilts



ENJOY A MAN'S KIND OF COMFORT . . . A MAN'S KIND OF CONTROL! You're in command of total comfort with this special chair that lets you control the relaxing action. Scientifically contoured and shaped to new space-age seating concepts for extending seating comfort.

ALL AROUND SWIVEL ACTION! For TV watching . . . for reading . . . for talking with guests . . . for pure relaxing fun.

GENTLE TILTING ACTION! Unique center balance control allows chair to swing into an infinite number of positions by shifting your weight.

RELAX AND UNWIND! In the hammock-like comfort of thick resilient foam. You are totally surrounded in the luxury of genuine Naugahyde upholstery. Rugged and distinctively man-styled!

YOU DESERVE YOUR OWN SPECIAL CHAIR! Where you can rest, relax and relieve tensions from the hectic pace of a busy day. Roomy size: 24" wide, 42" high.

ANIMAL RUGS—Perfect replicas, made from modacrylic fur . . . a tough, durable, stain resistant miracle material. Adds a special flair to your comfort center. Tiger Rug, size 5' x 9', or maybe you prefer a white Bear Rug, size 5' x 7', only \$98.50.

"TRY IT" ORDER FORM

Mail your order today. Get into the swinger . . . and enjoy yourself.

- Please send me the Lounger and matching Ottoman priced at \$124. Both items, shipped prepaid when check accompanies order. If you are not completely satisfied after using the lounger for two weeks, just return it to us and you'll receive a full refund immediately. Check Color desired:
- Black Burnt Orange Tan
 Avocado Oxblood
- Send me the Animal Rug at \$98.50 each
 White Bear Tiger

Name _____

Company/Institution _____

Address _____

City _____ State _____ Zip _____

Signature _____

You may charge these to your credit card, if you desire, (items shipped collect on charge account order).

Account Number _____

Diners Club American Express

Master Charge Bank # _____

Sales taxes, extra, if any.

EXECUTIVE DISCOUNT SHOPPING SERVICE
1309 Cherry Street/Phila., Pa. 19107

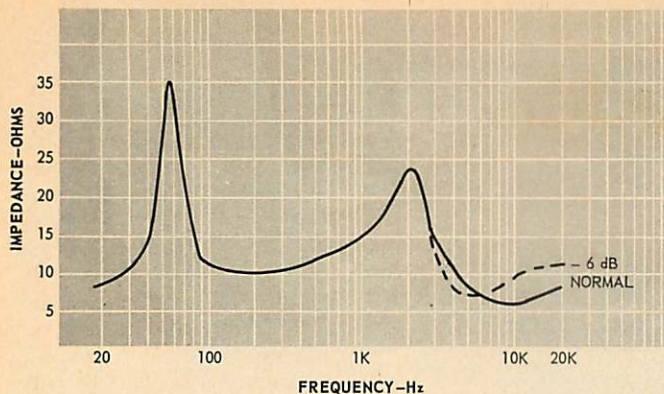

Fig. 2—Impedance throughout the frequency range, shown at two settings of the tweeter level control.

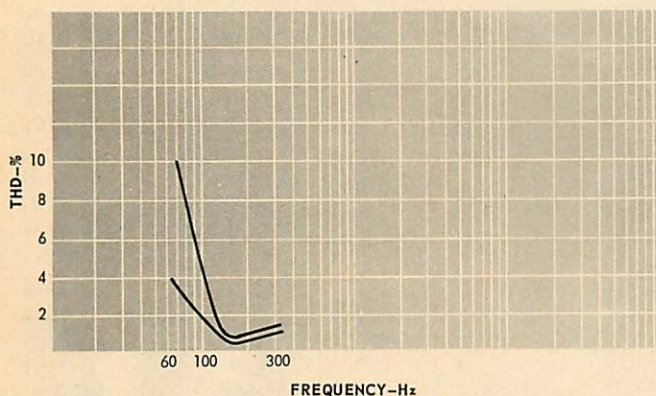

Fig. 3—Low frequency harmonic distortion at 95 and 100 dB SPL. Distortion is mainly of the second harmonic.

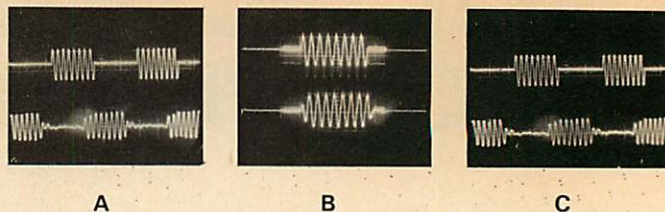

Fig. 4—Tone burst response at **A**, 100 Hz; **B**, 1000 Hz, and **C**, 10,000 Hz.

Fig. 1B. The averaged response curve, Fig. 1C, shows a small audible dip at 2,500 Hz, which is around the crossover point and smack in the middle of the “presence” region. The impedance curve of Fig. 2 shows this as a corresponding peak, as well as the speaker’s bass resonance at 60 Hz. The highs are fairly extended and non-directional. The speaker begins to roll off sharply at 60 Hz, which is to be expected from such a small box with relatively high efficiency. Input of 1.5 volts produced an 85 dB sound pressure level out at four feet, which is indeed efficient compared to other acoustic suspension bookshelf designs. It means that an amplifier with 20 watts rms power per channel will do nicely in driving the speaker in an average room. Its transient response was excellent, as can be seen in the toneburst photos of Fig. 4.

Listening Tests

In listening tests, the speaker had a clean, open sound, without the usual presence peak associated. Optimum balance in our room was with treble control set to the “-6 dB” position. The dip in the presence region is to be preferred to the usual rise since most recorded material suffers from excess brightness in this part of the frequency spectrum. We recommend this speaker to the audiophile who must work within the confines of a limited budget.

Alex Rosner

Check No. 46 on Reader Service Card

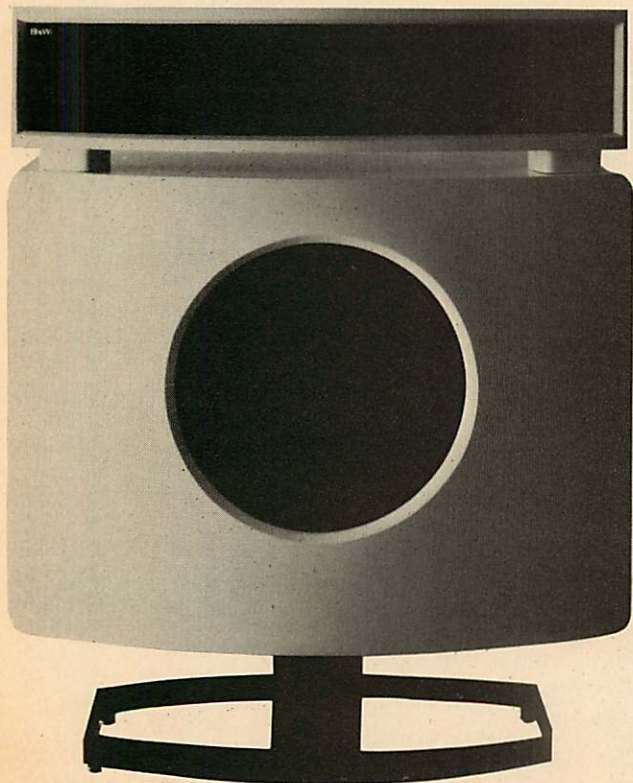

B&W 70 CA Loudspeaker System

MANUFACTURER'S SPECIFICATIONS

System Type: Two way; 13-in. triple-suspension woofer in infinite baffle enclosure and 11-segment electrostatic mid-range and treble unit. **Crossover:** 400 Hz, 18 dB per octave. **Frequency Response:** 25 to 18,000 Hz ± 3 dB. **Nominal Impedance:** 8 ohms. **Recommended Amplifier Power:** 50 watts per channel, minimum. **Weight:** 80 lbs. **Dimensions:** 26 in. W by 32 in. H by 15 D. **Price:** \$660.00

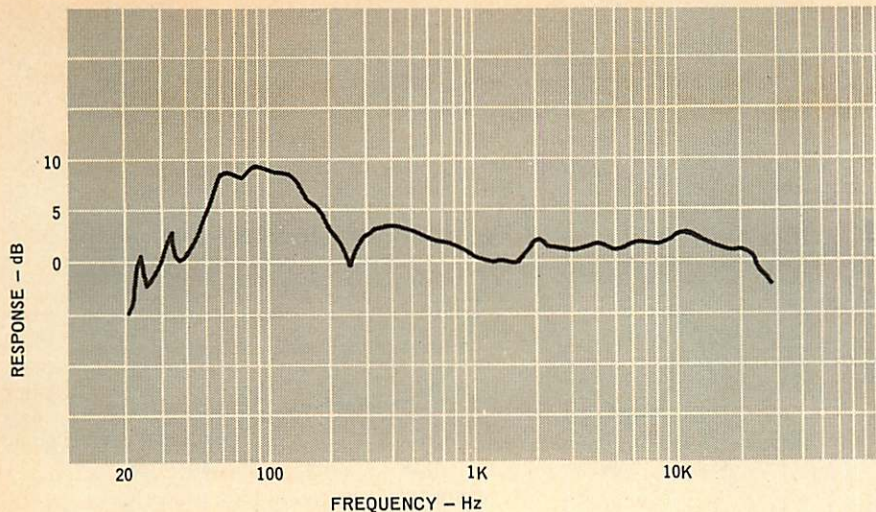

Fig. 1—Frequency response

The B&W 70CA is the American version of a British-made system that has been highly praised by European critics. It is a dynamic-electrostatic combination using a heavy 13-in. bass unit combined with a wide-angle electrostatic speaker. Its appearance is unusual as the electrostatic unit is not inside the enclosure but is placed on top where it is fixed by two plug-in metal dowels and mates to the energizer unit with a multi-pin plug using

gold-plated pins. The external mounting not only avoids diffraction effects, but it allows rear radiation as well, allowing the unit to act as a true bi-polar radiator. The unit is 27 in. long by 6 in. high with an arc of 80 degrees. The polarizing supply and crossover components are housed in the main enclosure. Crossover point is 400 Hz and special ferrite inductors are used with 74 μ F. paper capacitors. The bass speaker has a heavy laminated cone which is damped

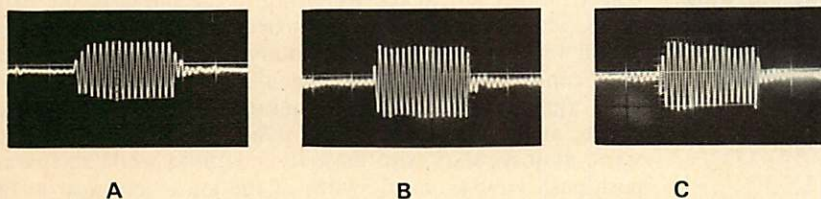

Fig. 2—Tone burst characteristics at A, 50; B, 1000, and C, 5,000 Hz.

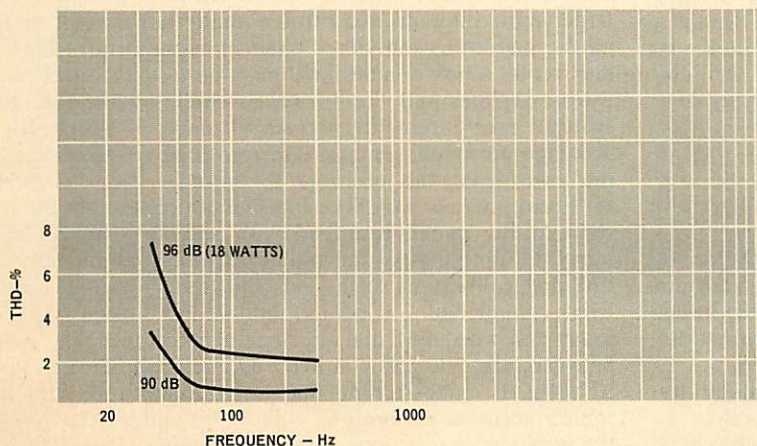

Fig. 3—THD at low frequencies.

by synthetic rubber pads. The enclosure itself is sealed and filled with fiberglass and the complete system stands some 32 in. high, so the high frequency radiation is at ear level and is not obstructed by furniture. As the leaflet says, "There is a basic objection to the reproduction of soloists appearing some 12 to 18 inches above the floor." The cabinet is constructed of 1-in. veneered chipboard—which partially accounts for the net weight of 80 lbs and bespeaks quality throughout. The finishes available are oiled walnut with a dark brown metal stand or white lacquer with a black stand.

Measurements

The first impression was of relatively low sensitivity and so the nominal 50-watt amplifier was changed for one giving a genuine 100 watts per channel. Second impression was the remarkably smooth white noise performance—easily one of the best I have yet heard from any system. Dispersion was outstanding and white noise tests show little variation over a 120° arc. Coloration at the low end was minimal and overall sound was excellent with a transparent quality particularly noticeable with choral groups and chamber music. The stereo image was excellent with a very wide listening area. Subsequent tests were made in a larger room (about 40 by 20 by 11 ft. high) and with a larger amplifier, a Phase Linear 700. Here it was more difficult to arrive at a good frequency balance. It is worth mentioning that this speaker, as with one or two other systems having an extended bass response, is somewhat sensitive to room acoustics and may set up standing waves. Placed in the corners the bass was still good but at high levels it tended to be overpowering with a trace of hangover. Some improvement was attained by bringing the speakers into the room away from the corners, but the most effective method was the use of an equalizer, actually a Soundcraftsmen 20-12. This was set to reduce frequencies in a broad band centering on 70 Hz. and then all was well. Next, measurements were taken in the lab and the frequency response, using one-third octave pink noise, is shown in Fig. 1. Figures were taken, as is our usual custom, up to 45 off-axis, plus an average of three additional curves, but in the case of the B&W 70CA, these did not differ significantly from the on-axis curves so are not shown. Figure 2 shows tone-burst characteristics at 50, 1000, and 5,000 Hz.

Bass response was well-maintained down to 32 Hz and doubling commenced at 70 Hz if driven hard. (The manufacturer, however, does not claim

that the 70CA is a theater type speaker capable of producing levels at or near the threshold of pain.) Figure 3 shows the distortion figures for the low frequencies at 90 and 96 dB power levels. The impedance showed a wide variation customary with electrostatic systems and is shown in Fig. 4. The lowest point was 2.7 ohms and the highest 53.7 ohms, but this should prove no problem with any self-respecting amplifier.

Further listening tests were made in other locations with the following conclusions; the B&W 70CA is unquestionably one of the best systems available at present, but it does need a lot of power (no big disadvantage these days). It is a speaker you should investigate if you are looking for high-quality no-compromise speaker system. T.A.

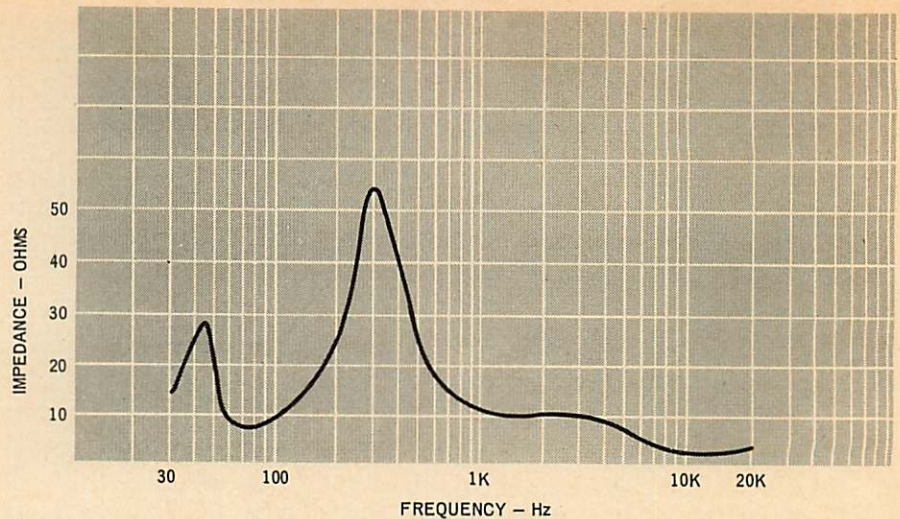

Fig. 4—Impedance characteristics.



Panasonic Model SA-5800

AM/FM Stereo Receiver

MANUFACTURER'S SPECIFICATIONS

AMPLIFIER SECTION. IHF Music Power: 75 watts at 8 ohms; 100 watts at 4 ohms. RMS Power: 27 watts/channel at 8 ohms; 37 watts/channel at 4 ohms. THD: 0.5%. IM Distortion: 0.7%. Power Bandwidth: 5 Hz to 40 kHz. Frequency Response: Phono, RIAA ± 1 dB; Aux, 15 Hz to 65 kHz $+0$, -3 dB. Input Sensitivity: Phono, 2 mV; Aux and Tape Monitor, 180 mV. S/N Ratio (IHF, A): Phono, 70 dB; Aux, 90 dB. Tone Control Range: Bass, $+13$, -14 dB @ 50 Hz; Treble, ± 10 dB @ 10 kHz. Damping Factor: 70 at 8 ohms.

FM TUNER SECTION. IHF Sensitivity: $1.8 \mu\text{V}$. THD (Mono): 0.4%. S/N Ratio: 60 dB. Selectivity: 80 dB. Spurious Response Rejection: 75 dB. I.f. Rejection: 100 dB. Image Rejection: 90 dB. AM Suppression: 45 dB. Capture Ratio: 1.5 dB. Stereo Separation (1 kHz): 35 dB.

AM TUNER SECTION. IHF Sensitivity: $15 \mu\text{V}$. Selectivity: 30 dB. Image Rejection: 65 dB. I.f. Rejection: 70 dB.

GENERAL SPECIFICATIONS. Dimensions: 16 in. W by $5\frac{1}{2}$ in. H by 14 in. D. Weight: 24 lbs. Retail Price: \$299.95.

Our first introduction to this excellent group of component receivers was in late 1971 when we reviewed Panasonic's then top-of-the-line Model SA-6500 (AUDIO, Nov. 1971). Embodying many of the same electronic features and "dress," the Panasonic Model SA-5800 is a moderate-power, moderately priced receiver with virtually all the control features of its bigger brother left intact. Referring to the photo of the front panel, which is made of heavy, extruded, light-gold anodized aluminum, you will note that rotary controls (as opposed to slide controls on the more expensive model) are used for BASS, TREBLE, BALANCE, and VOLUME. The SPEAKER selector switch, at the upper left of the panel, includes positions for MAIN, REMOTE, MAIN AND REMOTE OF PHONES while a separate push-push POWER on-off switch at the lower left, next to the headphone jack, enables you to leave all other control settings where you like them when the set is turned off. The tone controls of the SA-5800, though set by rotary knobs, actually offer more control than the "slide controls" provided on the larger unit, since each control is really a pair of concentric knobs, permitting individual channel adjustment of both bass and treble. A pair of additional push-push switches activate the HIGH-CUT filter and the LOUDNESS circuits while four toggle switches take care of STEREO-MONO mode, FM MUTING, and two tape MONITOR settings. The program selector switch, at the lower right, has positions for PHONO, AUTO FM (Stereo), FM MONO, AM, and AUX. The massive tuning knob at the upper right of the panel—equipped with smooth flywheel action, tunes the illuminated dial pointer across a completely linear FM dial calibration scale. This linear dial scale feature has been commented on before, but it bears repeating. With today's crowded FM dial, it's nice to have as much "spread" between, say, 106 and 108 MHz as you have between 90 and 92 MHz. It makes tuning that much easier and, with Panasonic's accurate calibration, almost eliminates the need for the popular "zero to one hundred" logging scale. (Panasonic includes it anyway!) The pointer, by the way, increases its

“glow” when a station has been properly tuned in, but then, of course, there is a center-of-channel tuning meter at the left of the dial for those who wish more definitive assurance of accurate tuning. When the AM mode is selected, the tuning meter needle swings over to the left and becomes a signal-strength meter, thus providing the optimum metering function for each of the two radio services. A stereo indicator light, as well as lights which show program source, are arranged above the dial scales and the dial is fully blacked out when power is turned OFF.

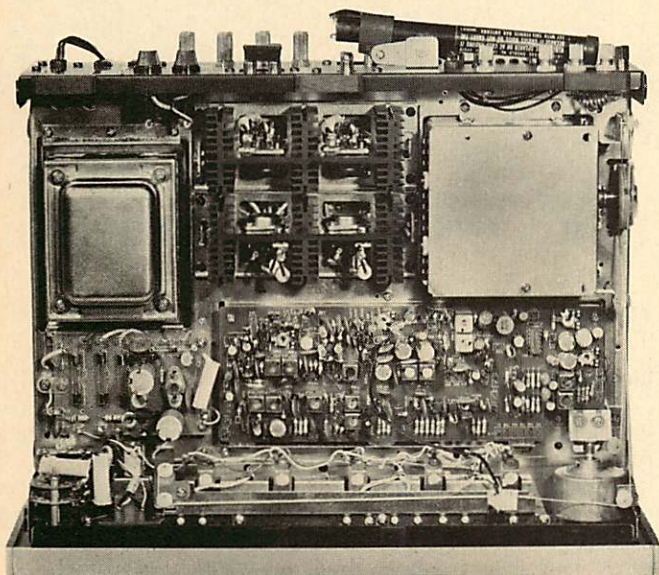

Fig. 1—Internal view.

The rear panel of the SA-5800, shown in Fig. 1, features balanced (300 ohm) and unbalanced (75 ohm) antenna terminals as well as a terminal for connection of an external AM antenna should the self-contained ferrite bar antenna prove inadequate in difficult AM reception areas. The usual input and record output jacks, practically short-proof main and remote speaker terminals, and a pair of convenience a.c. outlets (one switched and one unswitched) are sensibly arranged for easy access. In addition, there are a pair of speaker protection fuses, a center-channel output jack (requiring a power amplifier if it is to be used for a center-fill speaker system), and a pair of circuit jumpers which connect the preamp outputs to the power amplifier inputs. A DIN connector socket is wired in parallel with one of the tape monitor input and output jack pairs, for use with tape recorders equipped with this type of connector.

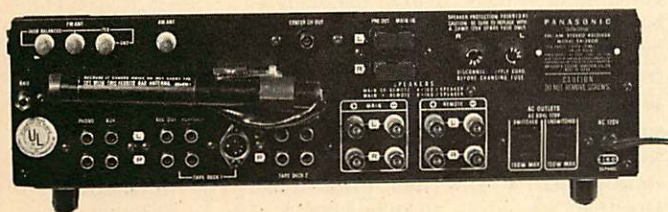

Fig. 2—Rear panel.

Figure 2 shows the internal chassis layout of this receiver. Construction is modular, employing a sealed front-end and a separate i.f. and multiplex p.c. board. The front-end employs two 4-pole MOS FET's and a specially constructed variable capacitor which is responsible for the linear FM dial previously described. A three-section tuning capacitor is used in the AM

section. The i.f. section includes four differential amplifier stages and six elements of ceramic filters in addition to conventional L-C tuned circuits. The multiplex circuitry is built around a single multi-purpose IC.

The power amplifier circuitry is direct coupled to the loudspeaker terminals and is powered by positive and negative supply voltages. Layout of the unit is well planned, with adequate heat sinking provided for the power output transistors.

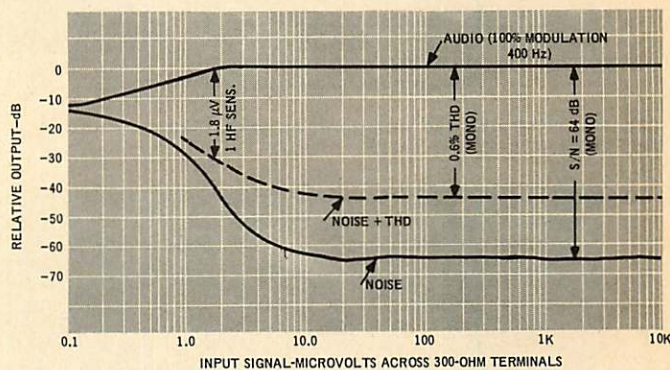

Fig. 3—Mono FM characteristics.

Electrical Measurements

FM monophonic performance is depicted in the graph of Fig. 3. IHF sensitivity turned out to be exactly $1.8 \mu\text{V}$, as claimed, while ultimate signal-to-noise ratio exceeded the 60 dB published figure by fully 4 dB, for a reading of 64 dB. THD in mono measured 0.6%, a bit poorer than claimed, but still in the “low distortion” category. Of interest is the quieting attained with a signal input of only 5 microvolts—it measures 58 dB on our unit. The 50 dB quieting figure (which we have come to consider as the *truly* usable input signal strength) occurs with an input signal strength of just under 3 microvolts.

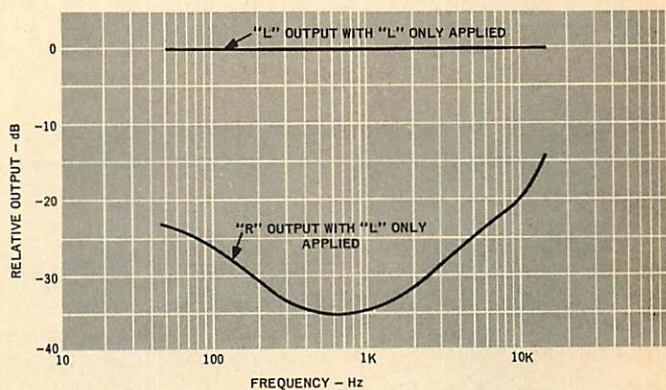

Fig. 4—Stereo FM separation characteristics.

Stereo FM separation is plotted in Fig. 4 and distortion characteristics (at mid frequencies) are shown in Fig. 5. While the THD curve confirms or exceeds published claims (rated distortion is reached at 29 watts per channel with 8 ohm loads as opposed to 27 watts claimed), the IM distortion curve reaches the rated figure at 26 watts—just below rated output.

Power bandwidth, shown in Fig. 6, extends from 6 Hz to 40 kHz, just about what is claimed for the unit. In addition

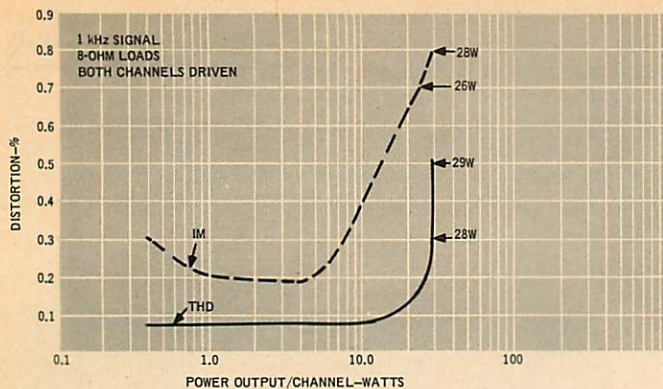

Fig. 5—THD and IM mid-band characteristics.

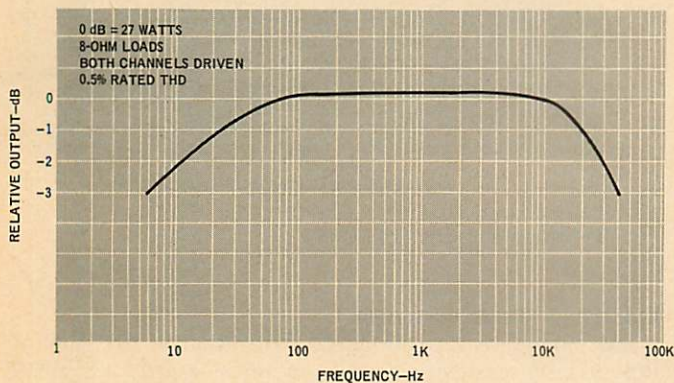

Fig. 6—Power bandwidth.

to these "full power output" measurements, we plotted harmonic distortion at all audible frequencies for two power output levels—10 watts per channel and 20 watts per channel. In each case, both channels were driven simultaneously and 8 ohm loads were used. The results are shown in Fig. 7 and, at the 20 watt level, THD approaches rated 0.5% only at the very lowest frequency measured. At the 10 watt level, all measurements at all frequencies were comfortably below the rated THD figure.

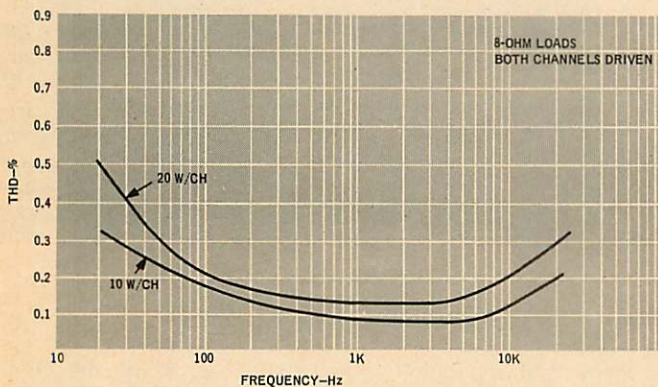

Fig. 7—Distortion vs. frequency at two power levels.

Figure 8 shows the preamplifier control ranges for bass, treble, high frequency filter, and loudness circuits and is seen to conform quite closely to published specifications. Though only one channel's results are shown, both channels were

within 1 dB of each other in both tone and filter action. The high frequency filter has a turnover frequency of approximately 5 kHz which makes it useful for noise reduction even though the slope is only 6 dB per octave. All equalization specs for phono inputs were within the 1 dB of the RIAA curve, as specified.

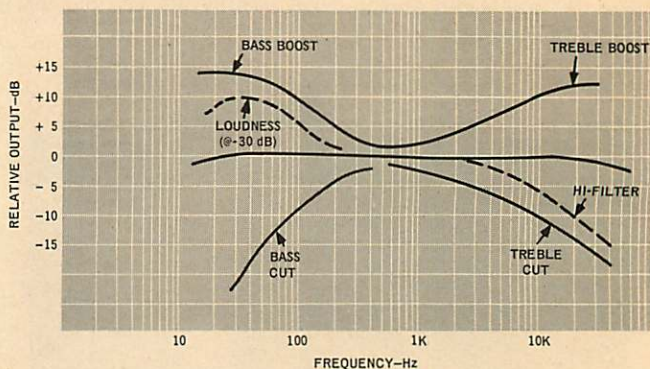

Fig. 8—Tone, filter and loudness control characteristics.

Listening Tests

Operated with medium efficiency speaker systems, the Panasonic SA-5800 had more than enough power to provide a room-filling clean musical program. In fact, two sets of such medium efficiency systems did not noticeably tax its power output capabilities. With really low efficiency types, however, the SA-5800 would have been unhappy with more than a single pair. Our listening room measures about 15 feet by 25 feet and might be classified as "medium" in its absorption characteristics.

The FM section behaved almost exactly like its counterpart in the more expensive Panasonic receiver tested some months ago, so that if you feel that 27 watts per channel is all the power you need in your installation, you need not worry about concomitant "downgrading" of the FM section—there isn't any. With the muting switch in the ON position we were able to receive some 44 signals acceptably, of which 26 were transmitting stereo programming. Defeating the MUTE circuit raised the number to 49, and of the new five, three were still acceptably free from background noise. This would seem to indicate that perhaps Panasonic should take advantage of its excellent quieting characteristic and re-adjust the muting threshold level to a somewhat lower point (there is no means for the user to perform this adjustment)—say 4 or 5 microvolts instead of the 7 μ V where it is now set.

It should be noted, too, that the AM circuitry of the SA-5800 is not a perfunctory addition. It really sounds noticeably better than a good many AM sections of other receivers we have tested, and when we listened to the one or two stations in our area which profess to transmit AM with increased frequency response, we could actually hear the difference. While no distortion specification is offered in the published specifications, we were so impressed with this "rarity" that we took the set back to our labs after the listening tests and were pleased to find that THD at 30% AM modulation was less than 1%—quite an achievement for the so-called "lo-fi" medium.

In summary, then, the Panasonic SA-5800 should make an excellent "electronic heart" of a stereo system in which super-high power is not required and where budgets are modest compared to the desire for near-perfection in performance.

Len Feldman.

Check No. 50 on Reader Service Card

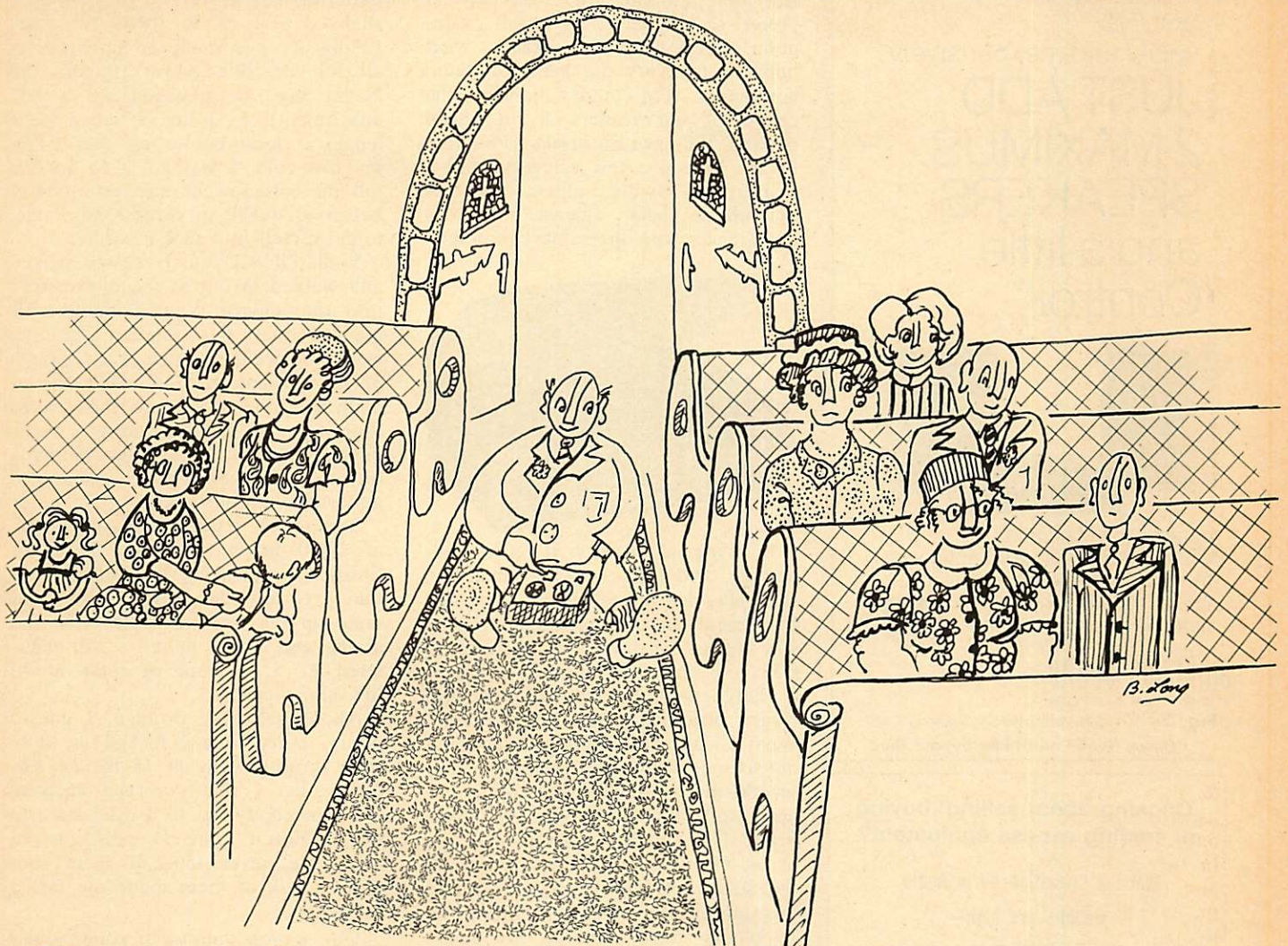

Recording At 15 ips On Batteries

I'M WALKING on air. I have just recorded the Canby Singers on flashlight batteries.

Don't misunderstand me. This was no flashy bit of humor. I meant serious business. The Canby Singers have two LP records on the market, old but still selling. We intend to make more. To do so, we must get down on tape our yearly production—before we move on to new music. At stake this year was a whole program of *a cappella* choral music, painstakingly prepared over many months and now ripe for harvest. Now or never. Get it down fast—or the music will die.

Next autumn, new singers, new repertory, and on we go.

But a recording date for a non-profit chorus of some 20 singers isn't easy to swing. For several years I

have been forced to let our current musical crop die on the vine, for lack of the right opportunity to get the singers, the music, the recording equipment and a suitable acoustic environment together at one time. Our last session, some years back, had produced a batch of fat 10-inch reels of tape, all Dolby A, via a large station wagon full of equipment in the normal professional manner. Since then—nothing.

You can imagine my mental clockwork when one day last spring a young man named Arthur Grudko called me: Would I like to look at the new Nagra S? He was on his way downtown to see me. Phew! A *stereo* Nagra? I had thought that this famed miniature pro machine came only in mono. Not any more. The Nagra S is here, all 11 pounds of it minus batteries (one dozen D cells) and it'll cost you about the

same arm & leg as a new Super Beetle with sunroof and white wall tires all around. Quicker than you can think, I thought I'd have me one, to take down our music this year. In stereo. (Next year—four-channel.)

But a serious recording session on *flashlight batteries*? Zany idea. Nevertheless, in no time at all, that is exactly what we did. And it worked, even though I worked myself up into a dozen quite needless states of high anxiety before we were done. I had a lot to lose, you understand, if the idea didn't pan out.

I have always believed in *involvement*, as the very best way for someone like myself to gather knowledge with which to write this column, or department, ETC. If my own personal interests are tied up in a venture, I am more than likely to become quite

To turn your present stereo system into Panoramic 4 CHANNEL SOUND easily and inexpensively

JUST ADD 2 MAXIMUS SPEAKERS and a little "Control"...



namely, the Maximus Quadrasound Control Center with the exclusive Blend Control for the ultimate in tone, balance and resonance.



MAXIMUS SOUND CORPORATION

Garden City, N.Y. MAXIMUS WEST, Gardena, Calif.

Check No. 54 on Reader Service Card

Thinking about selling, buying or trading excess equipment?

Place a Classified Ad in Audio.

Results are high—
Cost is Low!

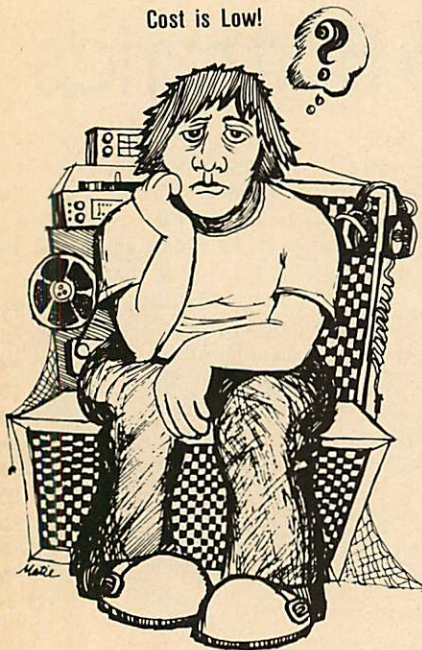

See classified section in the back of this issue for rates and to place your ad.

passionate in my investigations—and so write better, convey more. Flies in the face of objectivity, I know. But then, I'm not after objectivity. I prefer a subjective, involved evaluation, because that is exactly what happens to every purchaser of audio equipment. I'm merely joining the crowd of our readers, a bit ahead of time. We have EQUIPMENT PROFILES in the objective test category, and I read them avidly, please note. A marvelous check against my own experiences with the same equipment.



Involvement is risky. It's also challenging, and I like a good challenge. If I play my game rightly, pick my equipment on the assumption that it will not let me down, I'm likely to do OK, and that is a kind of triumph I really enjoy. So I called the local Nagra office and asked for a loan. What a loan! The Nagra people signed out to me, at my own deliberate risk, several thousands of dollars of brand-new stuff, including pairs of Sennheiser 405s and AKG omnis, and two of us, Grudko and I, set off to walk the streets of New York, down into the subway and out again, and 10 or 12 blocks more home to my apartment. No cabs, thank you! This was going to be an all-portable recording session from the word go. I confess that I shook with fear when various eyes in the crowded downtown express looked speculatively at the black leatherish case I carried and the black leather with shoulder strap that was slung over Arthur Grudko's shoulders. Frankly, I did not dare go alone—I was a bit *too* much involved, at that point. But Arthur had been on the Nagra sales force for eight weeks, carrying the stuff around everywhere with him, and he was utterly blasé. Nuttin' to it.

And so we drove some 50 miles out into New Jersey where we had located an acoustic surrounding absolutely superb for our music in the form of a modern church, part school gymnasium. Its identity shall be nameless. You go look for it. Downpour of rain—would my singers ever make it? Half hour lost, stalled behind a jackknifed trailer. Horrid thoughts hit

me right and left. Would the rain roar on the roof and ruin our ratio of S/N? Could happen! And those batteries. The nearer we got, the more shaky I felt as to their life span. Boldly, we had made no provision at all for a.c. line power (though the Nagra may be powered via a \$57 attachment). As I say, I like a challenge, at least before my feet begin to grow cold. I was going to do this job on batteries, or else. But now I began to quake in earnest. Idiot me, to get myself into such a corner!

Well, I'll tell you. First, we arrived and walked in out of the downpour—into utter silence. Wow! I should have guessed that this modern building would be well insulated, even though of modest construction, the walls of plain concrete block and the peaked roof of wood paneling. During a whole day of downpour, only a few plopping drip sounds from an overloaded gutter got into our mics.

Second—the pay-off. We got to work at 10:30 in the morning, late. We finished, exhausted, at around six that evening. The entire session was done on the one set of D cells—and at the end, those batteries still registered at 55 percent of their useful life. Unbelievable.

About half way through, I got so jittery, every time I looked at those reels turning away at 15 ips on batteries, that I finally turned chicken. Sent somebody out to a drug store to buy a dozen more D cells, just in case. We never touched them. But just to look at them made me feel a lot better.

Our session didn't run continuously all that time, of course. But it did include a lot of rewinding and play back, in order to check our musical results. To my nervous eye, the sight of 1800 feet of thin tape being rewound by battery power, again and again, was almost unbearable. I shouldn't have worried.

Playback was easy. We set up a compact audio system, brought along under the hood of my VW, in a school office next to the auditorium. Wall-to-wall carpeting and pictures all around, just like a good living room. You cannot judge recorded sound as played back in the same hall, unless you are one of those ultra-experienced freaks who can do it by intuition. For playback, we simply unhooked the tiny Nagra, carried it into the office and plugged it in—presto, we had sound. (Yes, I could have used another machine, powered via a.c., to spare those batteries, but that would have spoiled the game. The batteries were going to have to do all the physical



"Second Best" is getting better

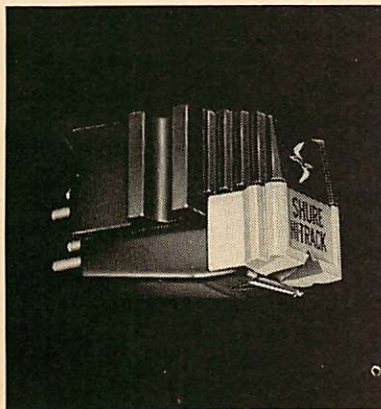

It used to be that every new cartridge made was doomed to near-obscure in the monumental shadow of our Shure V-15 Type II Improved Cartridge. The shadow is still there, of course, but with the introduction of our new *M91ED Cartridge*, the "second best" cartridge comes somewhat closer to the performance capabilities of the V-15 Type II—especially in the area of trackability. That's because the M91ED uses some of the same design principles used in the V-15 Type II: among them, a gem-quality diamond stylus tip that is "nude-mounted" directly on the stylus bar—decreasing stylus tip mass and increasing trackability. The M91ED reproduces the high recorded levels of modern pressings with ease—and at tracking forces that reduce record and stylus tip wear to a reassuring minimum. Suggestion: the new M91ED for modest budgets, the V-15 Type II Improved if only state-of-the-art perfection will do.

Shure Brothers Inc.,
222 Hartrey Ave., Evanston, Ill. 60204



Check No. 53 on Reader Service Card

and electronic labor involved in the recording itself.)

There were some minor hassles along the way. We had on hand a batch of Memorex tape, whereas the Nagra was set up for Scotch. Proper procedure would have been a laboratory recalibration of bias—which can be done to perfection on the Nagra via a combination of volt-

age settings (5) and trimmers for exact response. I decided to spare the company this task since time was short—we'd take a risk on compatibility. In the end, the Memorex came out on the brilliant side but not enough so to bother me. And in the subsequent treatment, would not a slight roll-off enhance our signal to noise? I figured so.

Playback connections? Luckily, I remembered in time. Nagra uses a Continental stereo plug, seven pins if I remember rightly. They sell a conversion cable, to RCA plugs. We borrowed one. Then there was the question of recording curve. Nagra is totally pro and therefore offers several including a special Nagramaster curve of inventor Kudelski's own devising, which claims a fantastically good S/N when used for mastering from the tape. I very nearly went for it, I tell you. If I had owned the Nagra, I would have used this curve without the slightest hesitation. Of course, you must play back your tapes on the Nagra itself in the process of mastering—to come out with an easy match for a full Dolby A tape, *plus* Dolby in addition if you wish. But for this, I would have had to borrow the Nagra once again, and my nerves didn't think they would be up to it.

So we cut tape to NAB on Memorex. And at 15 ips, in that astonishingly silent, big, live auditorium, we have a fabulously good result.

The 1800 feet? Another challenge. It isn't conventional to use 1 mil tape for making professional master recordings. In older days, there was danger of serious stretching, and the machinery could play havoc with this more delicate thickness of base material; moreover, print through was more likely, as were such post-operative failures as cupping, creasing and so on. But today, 1 mil tape is enormously improved—I decided it was another challenge, and I would take a risk on it. We'd have the full 1800 feet on seven-inch reels, to accommodate our longest musical works, movement by movement, a big musical advantage. I might add that it also is not conventional to use seven-inch reels for master recording. Nagra can't quite manage the big 10-inch monsters—after all, it's hardly bigger than just one of those reels, not to mention two of them.

I figured that with the Nagra's capabilities and today's remarkable new thinner tape, I was justified in using the 1 mil thickness for *this* rather special and slightly abnormal session. And so I did. But, ha ha, I'll tell you a secret. For those conservatives who may disapprove, I have a remedy up my sleeve. If need be, I can *copy off* my Nagra tapes onto ten-inch reels, with Dolby! I am quite certain that nobody will guess the difference. In fact, we may do this

(Continued on page 72)

The \$300⁰⁰ Concert Hall

With all the "great", "new", "fantastic", "innovative" things everyone's claiming, how do we prove we've got something remarkable?

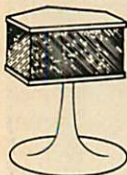

Lend us your ears. And eyes.

Walk into an authorized LDL high fidelity dealer with a favorite record or tape—hopefully, a demanding one. Ask him to hook up your present (or future) amplifier or receiver and a pair of LDL 749 reflecting speakers. And listen.

Listen to the "speakerless" clarity of a multiple-transducer crossoverless system using the finest components. If your record's got fundamental bass, the fundamental's what you'll hear, up to and including the *attack* of drums and strings. And as for highs, you won't just listen to them—you can pick them apart: violins, trumpets, piccolos and more—each clearly defined.

But good stereo (or quad) is more than

frequencies and transients put in their place: it's a spatial phenomenon. Which is where the LDL 749 really excels. Precisely combining forward-radiated sound from the front of the enclosure with panoramically-reflected sound from the rear. Result: the kind of acoustical environment you used to need a concert hall to get.

Need more convincing? A-B LDL 749's against other speakers—even the \$1000-a-pair variety. We honestly think you'll prefer ours.

Where do your eyes come in? To appreciate the speakers' compact size and elegant looks. Beginning with the \$299.95 pricetag ... for the *pair*. Now, where can you get a concert-hall for that?

For the name of your nearest dealer, write or call:



LINEAR DESIGN LABS, INC.
114 Wilkins Avenue, Port Chester,
N.Y. 10573 •



Dealer inquiries invited



**\$300.
Not For One... For Both!!!**

Classical Record Reviews

Edward Tatnall Canby

César Franck: Symphony in D Minor. Ravel: Fanfare from "L'Éventail de Jeanne." Hilversum Radio Philharmonic Orch., Stokowski. **London Phase 4 SPC 21061**, stereo, \$5.98.

Phase 4 triumphs again. This is an eccentric but remarkable version of the old symphonic war horse, done up splendidly by the engineers in super fi, yet in its musical interpretation projecting a style straight out of Stokowski's youth, say around 1910. Which just happens to be consonant with the neo-Romantic stylings now being worked up by our very youngest conductors. Stokowski's finger on the pulse, once again?

Halfway through the second movement a further thought hit me. Why was this style so familiar, whom did it remind of? Of course! Here is the apotheosis of *Willem Mengelberg*, that genius of the turn of the century whose immensely mannered conducting dominated the scene all the way up to the middle of WW II with his Concertgebouw Orchestra. With a start, I understood that this, too, is a Dutch orchestra, if not the Concertgebouw itself, then a distinguished orchestra in its own area, the radio. Could the old maestro be up to still further ingenuities? I wouldn't put it past him! A sense of history. With all the dramatic trimmings, à la Fantasia.

The Symphony is taken as no conductor under 65 would dare take it. Slowly, with great hesitations, changes in tempo, lingerings over lovely details, bringings-out of melodic turns and harmonic subtleties—it would be carnage in anybody else's hands (except Mengelberg). Unbelievable, but good, really good! We can only admire the brave Dutch orchestra, which follows the Maestro's baton-less hands (he never uses one) with absolute precision no matter what. Amazing. It is a convincingly "different" performance, and since this sort of thing definitely once was common in musical interpretation, the results are significant, not merely fluky.

You will not credit your ears when you hear the brief Ravel fanfare that opens the first side, before the Symphony. It was resurrected from a 1927 work (very late Ravel), a multi-composer children's ballet. The instruments enter in different keys, "modern" as all get-out and very much 1927. Remember, this was the period when

Ravel, in New York, became vitally aware of George Gershwin and of Harlem jazz—a musical influence that is obvious in both his piano concerti, if the performers allow it to get through. (Some of them don't.) Quite a fanfare, and you can put it on for your friends, who'll never guess.

Performance: A- Sound: A



Ravel: Bolero; La Valse; Pavane pour une infante défunte. Royal Philharmonic, Claude Monteux. **London Phase 4 SPC 21064**, stereo, \$5.98.

You can't hit every time, even with the best of prognoses. This one, with everything apparently going for it, is a curious dud. Claude Monteux is not only French in background but is the highly musical son of the late Pierre Monteux, one of the finest conductors of our age.

I think I can deduce the story. It happens that, only days before I listened to this record, Claude Monteux, live and in the flesh, conducted the second of two little concerts right in my home town in Northern Connecticut. The man is a superb musician! And one of the finest flute players I have ever heard. He has a natural stage presence too. He can conduct, talk informally and play flute, all, so to speak, in a breath. (How one can lead an *allegro* movement of a symphony, then casually turn around and play a flute solo to the second movement, right on the podium, is more than I can understand. Such *sang-froid!* Such breath control!) So, you see, the man is to be reckoned with.

The problem is one of style. Both the Monteux concerts I heard were of 18th century music. Claude Monteux is obviously a specialist in this area, both in conducting and in playing. From Bach to Mozart and Haydn, his styling and phrasing is impeccable and wonderful to listen to. But he must make his own reputation, and he does go by the name of Monteux. What would a typical A & R department do with such a name? Of course! Throw some standard French orchestral stuff at him. What else?

It just doesn't work. The frenetic and explosive *La Valse*, with its waves of controlled hysteria, just tries to stay urbanely Viennese as long as it can; the great succeeding climaxes are altogether muffed when they no longer can be denied. Distressful. The *Bolero*, growing steadily under a rigid pulse, is easier fare for a conductor—but even here Monteux & orchestra hideously miss the whole point of that hair-raising change of key at the end, which hurls itself into madness with the final hoarse, croaking chords (pardon my h's), like the hatchet-type ending of Richard Strauss's opera *Salomé*. Only the suave *Pavane* comes through convincingly on this record, and that one's easy.

How about some Phase 4 Haydn or Mozart or Telemann, via Claude Monteux? Please take note, London. That would be really something.

Performances: C+ Sound: B+

Harry Partch/Delusion of the Fury. Ensemble of Unique Instruments conducted by Donlee Mitchell, supervised by the composer. **Columbia M2 30576**, 2 discs plus bonus disc, stereo, \$11.98.

Here's Harry Partch again, the 70-year-old California genius eccentric who for 50-odd years has been inventing his own art instruments out of all sorts of odds and ends from eucalyptus boughs to abandoned hubcaps and light bulbs, giving them lovely names such as "Cloud Chambers," "Spoils of War," "Boo," and—last but hardly least—composing music for them, all in slithery quarter tones with masses of percussion, vast, stringy twangings, a generally sea-sick pitch-component, and an over-all old-fashioned sense of harmonic vestige from the ripest 19th

century! Not unlike Charles Ives, when you come down to it.

The bonus disc, an extra LP, is a valuable account by Mr. Partch himself of each of his instruments, each one sampled for sound; and Columbia has added a vital visual component, color pictures of each of the instruments in the order that they are played and described. The rest of the set, four very full LP sides, goes to the most recent Partch super-piece, an enormous work on a Mahleresque scale in which most or all of the described instruments may be heard in operation.

Those over 30 (and under 70?) would do best to avoid the printed "Delusion of the Fury" story line, which gets bewildering, what with mixtures of Japanese Noh, African folk, U.S. hobo and so on. This is a "live" multi-media work and the story is important if you are watching as well as listening. Since you aren't, forget it. Just listen, and let the twangs and thumps and clangs roll over your ears like a cross between a Raga and a Gamelan, with those oddly faint echoes of California Brahms-out-of-tune. It's a weird mixture and, if I may so, very California.

For all its complexity and immensity, I can't help feeling that Harry Partch's music, like that of Charles Ives, is less well jelled than the sounds put forth by many a lesser but more stylized contemporary composer. For me, at least, the visual and pragmatic beauty of his unique instruments is more important—they are totally fulfilled and wholly original, whereas the music is maybe two-thirds baked, full of undigested 19th century stuff. Not so the visuals! They are astonishingly beautiful, these Partch creations. Partch himself is California at its zany best.

Performances: A+ Sound: A-

Gilbert & Sullivan: H.M.S. Pinafore. D'Oyly Carte Opera Co., Royal Philharmonic Orch., James Walker. **London Phase 4 SPCA 12001** (2 discs), stereo, \$11.96.

Lordy, Lordy, what they've done to G & S! Come, come, now, you Phase 4 people (and you newest generation of D'Oyly Carte singers), I was a British Sailor Lad in "Pinafore" at 16 and sang out with the best of them; moreover, I collected a brace of the very first D'Oyly Carte 78 albums, "Trial by Jury" and this very opera included—recordings which have long been sanctified among Savoyards as *the* authentic G & S tradition for all time. I know every note by heart. They don't sound like this.

Advertising Index

Advertiser	Page	Advertiser	Page
Akai Electric Co.	17	Mid-West Hi-Fi Wholesalers	67
Tape Recorders		Wholesale Price List & Catalog	
Check No. 17 on Reader Service Card		Check No. 68 on Reader Service Card	
AKG	14	North American Phillips Corp.	14
Microphones		AKG Microphones	
Check No. 14 on Reader Service Card		Check No. 14 on Reader Service Card	
Audio Dynamics Corp.	24	Panasonic	5
Speakers		Receivers	
Check No. 24 on Reader Service Card		Check No. 5 on Reader Service Card	
BASF Systems, Inc.	63	Phase Linear	62
Magnetic Tape		Model 400 Power Amplifier	
Check No. 61 on Reader Service Card		Check No. 62 on Reader Service Card	
BSR (USA), Ltd.	58	Pickering & Co., Inc.	29
Model 810 Turntable		Phono Cartridges	
Check No. 59 on Reader Service Card		Check No. 28 on Reader Service Card	
British Industries Corp.	3	Pioneer Electronics, Inc.	9
Zero 100 Turntable		SEL-40 Headphone	
Check No. 3 on Reader Service Card		Please Write Direct.	
Clark Co., Inc., David	65	Revox Corp.	66
Stereo Headphones		Bib Groove-Kleen & Beyer Headphones	
Check No. 65 on Reader Service Card		Check No. 66 on Reader Service Card	
Dolby Laboratories, Inc.	7	Rogersound Labs	67
Dolby Noise Reduction System		Speaker Systems	
Please Write Direct.		Check No. 67 on Reader Service Card	
Dynaco, Inc.	27	Sansui Electronics	13
Speaker System		Decoder/Amplifiers	
Please Write Direct.		Check No. 13 on Reader Service Card	
Eastman Sound	11	Schwann Record & Tape Guide	59
Martin Speakers		Guide to Current Records and Tapes	
Check No. 11 on Reader Service Card		Please Write Direct.	
Electro-Voice, Inc.	10	Scott, Inc., H. H.	Cover II, 1
Decoder/Amplifier		Receivers	
Check No. 10 on Reader Service Card		Check No. 100 on Reader Service Card	
Fairfax Industries, Inc.	37	Sharpe Audio Div., Scintrex	2
Speaker Systems		Stereo Headphones	
Check No. 37 on Reader Service Card		Check No. 2 on Reader Service Card	
Harman-Kardon, Inc.	31	Shure Bros., Inc.	53
Model 930 Receiver		Phono Cartridges	
Check No. 31 on Reader Service Card		Check No. 53 on Reader Service Card	
Hitachi	23	Sony Corp. of America	21
Stereo Components		SCT-7000 Tuner/Preamplifier	
Check No. 23 on Reader Service Card		Check No. 21 on Reader Service Card	
KLH Research & Development, Inc.	15	Sony/Superscope, Inc.	57, 65
Speaker Systems		Tape Recorder Accessories	
Check No. 15 on Reader Service Card		Check No. 63 on Reader Service Card	
Linear Design Labs, Inc.	54	Southern Sound Wholesalers	71
LDL 749 Speaker System		Mail-Order Discount Prices	
Please Write Direct.		Check No. 71 on Reader Service Card	
Marantz Co.	Cover IV	Stanton Magnetics	19
Model 250 Amplifier		Phono Cartridges	
Check No. 43 on Reader Service Card		Check No. 19 on Reader Service Card	
Martin	11	Stereo Component Center	71
Speaker Systems		Price List on Top Brands	
Check No. 11 on Reader Service Card		Check No. 70 on Reader Service Card	
Matsushita Electric	5	Sun Stereo	58
Receivers		Components & Systems	
Check No. 5 on Reader Service Card		Check No. 58 on Reader Service Card	
Maximus Sound	52	TEAC Corp. of America	Cover III
Speaker Systems		Tape Recorders	
Check No. 54 on Reader Service Card		Check No. 29 on Reader Service Card	
McIntosh Laboratories, Inc.	57		
MX-112 Tuner/Preamplifier			
Check No. 57 on Reader Service Card			

USE THESE FREE REPLY CARDS FOR:

More facts and free literature about the products described and advertised in this issue. Check the appropriate box for immediate results.

Please fill out the name and address information to get product info, order literature, or subscribe to **AUDIO**.

We editors would like to know about you readers, what your interests are, what you want to read about. This assures you of interesting, informative, helpful articles—geared to your needs.

Want to buy, trade or sell components? Want to offer or buy a service? Want a job in the audio field. Then your classified ad belongs in **AUDIO**! Rates are low—results high. Just fill out the handy, postage-free card.

Just \$6.00 For One Year!
Subscribe to **AUDIO**. Start reading the most exciting magazine for stereo enthusiasts. If you already subscribe, here's a chance to re-new your subscription before it runs out!

CLASSIFIED ORDER CARD

Want to buy, trade or sell components? Looking for a rare piece of equipment? Want to offer or buy a service? Want a job in the audio field? If your answer is "yes" to any of these questions, your ad belongs in **Audio Classified**. Rates are comfortably low—readership is astoundingly high. Use this handy order form to include your message in the next issue.

PLEASE CHECK ONE:

- | | |
|---|---|
| <input type="checkbox"/> For Sale | <input type="checkbox"/> Insert in next issue |
| <input type="checkbox"/> Wanted to Buy or Trade | <input type="checkbox"/> Insert in next 2 issues |
| <input type="checkbox"/> Situation Wanted | <input type="checkbox"/> Insert in next 6 issues |
| <input type="checkbox"/> Help Wanted | <input type="checkbox"/> Insert in next 12 issues |
| <input type="checkbox"/> Services | <input type="checkbox"/> Assign box number |
| Other _____ | (additional cost \$1) |

RATES: Commercial, 50¢ per word; situation wanted or non-commercial, 25¢ per word. We reserve the right to determine classification as commercial or non-commercial. **Payment must accompany all orders under \$10.00.**

COPY FOR YOUR AD

Name _____

Address _____

City _____

State _____ Zip _____

AUDIO is sold at these dealers

- Lafayette Elect., 1770 Belt Line Hwy, Mobile Ala
- Stereo Wholesalers, 500 Cloverdale Rd, Montgomery Ala
- The Record Shop, 123 Normandale Arc, Montgomery Ala
- Hi-Fi Sales, 764 W Main, Mesa Ariz
- Jerry's Audio, 120 E University, Temple Ariz
- Custom Stereo, 4815 E Speedway Blvd Tucson Ariz
- Henry Radio, 931 N. Euclid, Anaheim Calif
- Brinton's, 546 Carmel RNH Shpg Ctr, Carmel Calif
- Hi-Fi Matic, 5554 Sepulveda, Culver City Calif
- Lafayette Radio, 8553 Washington, Culver City Calif
- Reese's, 418 E Grand Ave, Escondido Calif
- Dunlap Electronics, 1750 E. McKinley, Fresno Calif
- Sun Stereo, 3209 Marks, Fresno Calif
- Sav-On Electronics, 13225 Harbor, Garden Grv Calif
- Filbert Co, 1100 Flower St, Glendale Calif
- Pacific Radio, 1351 Cahuenga, Hollywood Calif
- Schaeffer's, 1553 N Cahuenga, Hollywood Calif
- Universal News, 1655 N Las Palmas, Hollywood Calif
- Yale Radio, 6616 Sunset, Hollywood Calif
- University Supply, 1147 Anderson, Loma Linda Calif
- Scott Audio, 266 Alamitos, Long Beach Calif
- Ametron, 7355 Melrose, Los Angeles Calif
- SND Foyer Radio, 1421 S Hill, Los Angeles Calif
- Henry's, 835 S Olive, Los Angeles Calif
- Henry Radio, 11240 W Olympic, Los Angeles Calif
- Semler Photo, 5730 Wilshire, Los Angeles Calif
- Pacific Radio, 1116 7th St, Modesto Calif
- Sound Room, 529 Ramona, Monterey Calif
- Lafayette Radio, 1252 E Colorado, Pasadena Calif
- Stereo West, 782 Higuera, San Luis Obispo Calif
- Pacific Stereo, 2828 Wilshire, Santa Monica Calif
- Pete's 178 S Murphy, Sunnyvale Calif
- Sunnyvale Electronics, 548 S Murphy, Sunnyvale Calif
- Woodland Stereo, 21128 Ventura, Woodland Hills Calif
- Book Home, 119 E Dale, Colorado Spgs Colo
- Francis Electronics, 565 Long Hill Rd, Grotton Conn
- Lafayette Rad, 357 N Main, W Hartford Conn
- Lafayette Radio, 391 Broad, Manchester Conn
- Stereo Lab, 158 State, New London Conn
- Atlantic Elect, 581 Newfield, Stamford Conn
- Kleins, 44-50 Main, Westport Conn
- Glen Music, 1206 G St NW, Washington D C
- Fidelity Shop, 420 NW 13th St, Gainesville Fla
- Electronic Equip, 2701 NW 42nd St, Miami Fla
- House of Sound, 141 Lakeview, W Palm Beach Fla
- Sonic Stereo, 1143 Prince, Athens Ga
- Franklin Music, Perimeter Mall, Atlanta Ga
- Stereo Center, 666 Peachtree N E, Atlanta Ga
- Lafayette Radio, 4610 Memorial Dr, Decatur Ga
- Clark Electronic, 3222 Pio Nono Ave, Macon Ga
- Audio Center, 1020 Auahi St, Honolulu Hi
- Musicraft, 48 E Oak St, Chicago Ill
- Radio Shack, 24 Crystal Lake Plaza, Crystal Lake Ill
- Audio Consultants, 517 Davis, Evanston Ill
- World of Music, 100 N Chicago St, Joliet Ill
- Hi Fi Hutch, 524 E Northwest Hwy, Mt Prospect Ill
- Lafayette Radio, 2003 Philo Rd, Urbana Ill
- Risley Electronics, 2227 W Franklin St, Evansville Ind
- Lafayette Radio, 3101 N Clinton, Ft Wayne Ind
- Sampsons Card, 307 Main St, Cedar Fls Iowa
- Faber Music, 1157 Central, Dubuque Iowa
- McClelland Sound, 121 N River St, Wichita Kans
- Lafayette Radio, 584 Commonwealth, Boston Mass
- Lafayette Radio, 899 Boylston, Boston Mass
- Minute Man Radio, 30 Boylston, Cambridge Mass
- Custom Electric, 32 Center St, Chicopee Mass
- Stromboli, 180 Lisbon St, Lewiston Me
- Audio Associates, 10217 Old Georgetown Rd, Bethesda Md
- Hi Fi Buys, 618 S Main, Ann Arbor Mich
- Hi-Fi & TV Ctr, 3731 Washtenaw, Ann Arbor Mich
- Pentronics, 3386 Washtenaw Rd, Ann Arbor Mich
- Nutronics, 315 Hamilton, Birmingham Mich
- Barton Electronics, 1326 Broadway, Detroit Mich
- Sound Room, 3635 28th St Se, Grand Rapids Mich
- Kaltronic, 214 N Rose St, Kalamazoo Mich
- The Sound Room, 1228 S Burdick, Kalamazoo Mich
- Robbie Electronics, 33760 Plymouth Rd, Livonia Mich
- Sound Center, 429 N 3rd St, Marquette Mich
- Eric Electronics, 10721 W Ten Mile Rd, Oak Park Mich
- L R E Electronics, 34208 Van Dyke, Sterling Hts Mich
- Walker's Music, 118 S Union St, Traverse Cty Mich
- Lafayette Radio, 8976 Jennings Stat Rd, Jennings Mo
- Best Sound, 1131 S Brentwood, St Louis Mo
- Hi-Fi Fo-Fum, 3659 N Lindbergh, St Louis Mo
- Hi-Fi Fo-Fum, 1155 Big Bend Blvd, St Louis Mo
- Hi Fidelity Showroom, 6383 Clayton Rd, St Louis Mo
- Hurd's, 2718 S Glenstone, Springfield Mo
- Sound Center, 3rd St, Clarksdale Miss
- Marshall Electronics, 428 N Main, Helena Mont
- Lumbard-Leschinsky, 109-111 E 3rd St, Grand Island Nebr
- Custom Electronics, 4448 S 84th St, Omaha Nebr
- Melody Shop, 102 Main St, Keene NH
- Franklin Music, 158 Echelon Mall, Cherry Hill NJ
- Lafayette Radio, 195-A Route 18, E Brunswick NJ
- Lafayette Radio, 139 W Second, Plainfield NJ
- Hi Fi House, 3001 Monte Vista N E, Albuquerque NM
- Terrys, 106 W Coal Ave, Gallup NM
- Mannie's, 802 S Solano Dr, Las Cruces NM
- Grand Central Radio, 124 E 44th St, New York NY
- Harvey Radio, 2 W 45th, New York NY
- Liberty Music, 76th St & Madison, New York NY
- Lyric Hi-Fi, 1221 Lexington, New York NY
- Midway Radio, 60 W 45th, New York NY
- Packard Elect, 33 Union SQ W, New York NY

BUSINESS REPLY MAIL
No Postage Necessary if Mailed in the United States

POSTAGE WILL BE PAID BY:

AUDIO

134 North Thirteenth St.
Philadelphia, Pa. 19107

CLASSIFIED ORDER CARD Fill in other side to order a classified ad

BUSINESS REPLY MAIL
No Postage Necessary if Mailed in the United States

POSTAGE WILL BE PAID BY:

AUDIO

134 North Thirteenth St.
Philadelphia, Pa. 19107

SUBSCRIPTION ORDER CARD Fill in other side to order a new subscription

FIRST CLASS
Permit No. 22489
Philadelphia, Pa.

AUDIO is sold at these dealers

- Stereoland Inc, 68 Water St, Binghamton NY
- Laco Electronics, 4924 Fourth Ave, Brooklyn NY
- F M Sound Equip, 1241 Main, Buffalo NY
- Purchase Radio, 747 Main, Buffalo NY
- F M Sound, 4510 Bailey, Eggertsville NY
- Stellar Ind, 10 Graham Rd W, Ithaca NY
- Lafayette Electronics, 165-08 Liberty Ave, Jamaica NY
- Lafayette Rad, 5288 Sunrise Hwy, Massapeque NY
- Superior Sound, 1801 Brewerton Rd, Mattydale NY
- Hyatt's Stereo, 171 S Goodman, Rochester NY
- Stereo Sound, 169 Jay St, Schenectady NY
- Audio World, 2910 Erie Blvd E, Syracuse NY
- Lafayette Radio, 3001 Ridge Rd, W Seneca NY
- Arnee Audio Design, Nine Mall Wappings Fls NY
- Harvey Radio, 60 Crossways Pk W Woodbury NY
- Hi-Fidelity Sls, 180 Baltimore Ave, Asheville NC
- Womack Elect, 417 N Salisbury St, Raleigh NC
- Morrison Radio, 331 Center St, Ashtabula Ohio
- United Radio, Summit & Reinhold, Cincinnati Ohio
- Hi Fi Audio, E McMilliam & Woodburn, Cincinnati Ohio
- Hoffmans, 5931 Smith Rd, Cleveland Ohio
- Anderson Hi Fi 2244 Neil Ave, Columbus Ohio
- Custom Stereo, 1391 S Hamilton Rd, Columbus Ohio
- Univ Audio, 1604 N High St, Columbus Ohio
- Palmer Electronics, 3560 N High St, Columbus Ohio
- Jimmy Rea Electronics, 540 W Broad St, Columbus Ohio
- Lafayette Radio, 4676 W Broad St, Columbus Ohio
- Custom Elect, Van Burne Shopping Ctr, Dayton Ohio
- Stotts-Friedman, 108 N Jefferson St, Dayton Ohio
- Allied Service Ctr, 34545 Vine St, Eastlake Ohio
- Commercial Music, 303 Cedar Hill Rd, Lancaster Ohio
- Lafayette Rad, 75 Bi Mentor Ave, Mentor Ohio
- Winteradeo Elec, 5373 Ridge Rd, Parma Ohio
- Valley Electronics, 264 W Market St, Warren Ohio
- Lafayette Radio, 21907 Emery Rd, Warrensville Ohio
- Capitol Electronics, 6500 North May, Oklahoma City Okla
- Lafayette Radio, 2220 S W 74th St, Oklahoma City Okla
- Hunters, 4059 NE Sandy, Portland Oreg
- Oregon Hi Fi, SW 5th & Washington, Portland Oreg
- Wassons, 631 NE Grand Ave, Portland Oreg
- Central Radio, 1194 Merchant St, Ambridge Pa
- C & S Distributors, 7 N 21st, Camp Hill Pa
- Franklin Music, Neshaminy Mall, Cornwalls Hts Pa
- Eynon Drug, Rt 6, Eynon Pa
- Wander Sales, Greengate Mall, Greensburg Pa
- Wander Sales, 325 Fifth Ave, McKeesport Pa
- Wander Sales, Monroeville Mall, Monroeville Pa
- Television Parts, 518 5th Ave, New Brighton Pa
- Sam Goody, 1125 Chestnut St, Philadelphia Pa
- Tech Hi Fi, 4034 Walnut, Phila Pa
- Soundpiper, 1835 Murray Ave, Pittsburgh Pa
- Home Music, 510 Market St, Pittsburgh Pa
- Lafayette Rad, 4801 McKnight Rd, Pittsburgh Pa
- Record-Rama, 639-41 Butler St, Pittsburgh Pa
- Opus One, 400 Smithfield St, Pittsburgh Pa
- Wander Sales, 7901 McKnight Rd, Pittsburgh Pa
- Wolks Kamera, 312 Forbes Ave, Pittsburgh Pa
- Franklin Music, Plymouth Meeting Mall, Plymouth Mtg Pa
- Electronics Dist, 201 S 4th St, Reading Pa
- Wander Sales, Eastland Shopping Ctr, No Versailles Pa
- Sound-O-Rama, 758 Reservoir Ave, Cranston RI
- College Hi-Fi, 5768 Brainerd, Chattanooga Tenn
- Watkins Stereo, 1019 Center St E, Kingsport Tenn
- Stubler's, 1523 Union Ave, Memphis Tenn
- Electra Dist, 1914 W End Ave, Nashville Tenn
- Nicholsons, 115 19th Ave So, Nashville Tenn
- Miller Clinic, 602 Gallatin Rd, Nashville Tenn
- Capitol Electronics, 1800 Washington, Amarillo Tex
- High Fidelity Inc, 1710 Lavaca St, Austin Tex
- Home Entertainment, 7530 Burnet Rd, Austin Tex
- Discount Records, 4003 Northwest Pkwy, Dallas Tex
- Hillcrest Hi Fi, 6307-09 Hillcrest Ave, Dallas Tex
- Howell Electronics, 2873 Perching, El Paso Tex
- B & M Electronics, 3717 S Shepherd Dr, Houston Tex
- Home Entertainment, 5310 Kirby Dr, Houston Tex
- Home Entertainment, Nasaau Bay Shpgg Ctr, Houston Tex
- Cowl's, 1212 Hidalgo, Laredo Tex
- Hi Fidelity, 2217 34th St, Lubbock Tex
- McAllen Radio, 415 S Broadway, McAllen Tex
- Barton Elecs, 1023 N Midkiff, Midland Tex
- Midland Camera, 317 N Colorado, Midland Tex
- Electronics Unlimited, 61 Richardson Hts Vilg Richardson Tex
- Case Sound, 3522 Broadway, San Antonio Tex
- Cole Electronic, 335-337 S Bonner, Tyler Tex
- House of Music, 156 S Main, Salt Lake City Utah
- Audio Associates, 3441 Fairfax Dr, Arlington Va
- Audio-Tronics, 113 N Main St, Blacksburg Va
- Carver's, 153 College Ave, Blackburn Va
- Lafayette Radio, Wilson & Roosevelt Aves, Falls Church Va
- Lafayette Rad, 1730 E. Little Creek Rd, Norfolk Va
- Sound Shop, 7862 Tidewater Dr, Norfolk Va
- Audio Fidelity Corp, 6521 W Broad St, Richmond Va
- Audio Fidelity Corp, 3032 Trinkle Ave NW, Roanoke Va
- Capital Recording, 7085 Brookfield Plz, Springfield Va
- Lafayette Rad, 5112A Virginia Bch Blvd Virginia Bch Va
- Lafayette Radio, 14402 Jeff Davis Hwy, Woodbridge Va
- Stereo Component Ctr, 465 1/2 High St, Morgantown W Va
- Electricraft, 5030 Roosevelt Way N E, Seattle Wash
- Huppins Hi Fi, 419 W Main Ave, Spokane Wash
- Hal's Stereo, N 2514 14 Div St, Spokane Wash
- Consumer Electr, 518 N Appleton St, Appleton Wis
- TV-Hi Fi Center, 117 W Milwaukee St, Janesville Wis
- Discount Records, 434 W Wisconsin Ave, Milwaukee Wis
- Hi-Fi Fo-Fum, 2532 W Wisconsin Ave, Milwaukee Wis
- Hi Fi Salon, 7204 W Greenfield, Milwaukee Wis

©1972 Superscope, Inc., 8142 Vineland Ave., Sun Valley, Calif. 91352

**When you make the finest
tape recorders,
you've got to make the
finest tape recorder
accessories - Sony.
Right? Right!**



Check No. 63 on Reader Service Card

**FREE McIntosh CATALOG
and FM DIRECTORY**

Get all the newest and latest information on the new McIntosh Solid State equipment in the McIntosh catalog. In addition you will receive an FM station directory that covers all of North America.

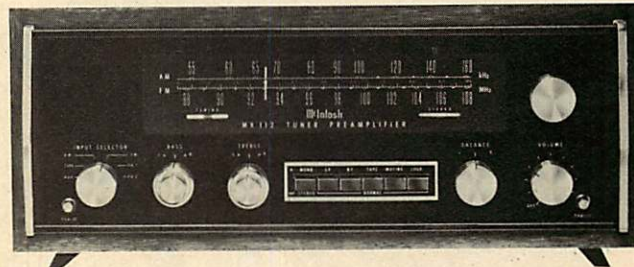

**MX112
FM STEREO/AM TUNER PREAMPLIFIER
- ALL SOLID STATE**

**SEND
TODAY!**

McIntosh Laboratory Inc.
2 Chambers St., Dept. AE11
Binghamton, N.Y. 13903

NAME _____

ADDRESS _____

CITY _____ STATE _____ ZIP _____

Check No. 57 on Reader Service Card

GET SUN INTO YOUR SYSTEM

Sun Stereo offers more system for your money with every major line in stock (including blank tape and headphones). Add to your present system by mail. Many items sold at a fraction of the list price. Low cost and speedy shipping. Call or write for quotes and orders.

Send for your free quotes, catalog and literature.



Name _____

Address _____

City _____ State _____ Zip _____

3209 N. Marks • Fresno, Calif. 93705 • (209) 485-5420

Check No. 58 on Reader Service Card

Harrumph. I think maybe I like this better. Even tho the old guard will rip out its sparse, graying hair if it ever dares to listen.

This version, at last, brings G & S totally up to date in terms of modern recording techniques, complete with multiple stereo effects and startling mix-downs of sound never imagined either by G or S. *Sea gulls!* After all, aren't we at the shore? Ranks of sailors marching about. Scads of people all over the place (especially if you listen via four-channel), a perfect pageant of sonic scenery into which the familiar G & S tunes and patter fit as though they'd always been there. This is no staged opera! We are right on the deck of the good ship Pinafore, for fair, and anything goes, so long as it adds to the decor. Imagine it! Almost before the Overture is done, we are in the midst of crowds of people, and the hustle and bustle keeps us right on that famous deck, with sailors, sisters-cousins-and-aunts, and all the familiar principals around us, from Poor Little Buttercup and Captain Corcoran to the famed Sir Joseph Porter, K.C.B. And phew—you should hear the scene when Sir Joseph, the ruler of the Queen's Nay-vee (*not Nah-vee*) is elaborately piped on board, bosun's pipes shrilling, orders bawled out, sailors snapping to attention down there on the dock, and all those lovely sisters and cousins and aunts fluttering about the great man just the way you always supposed they would. Absorbing.

Equally fine is the spirit of the performance, once again fully alive, after too many years of tired G & S—the old mannered style gradually losing its force. (It was splendid in its day but that is no longer.) These are more musical singers than in the past and they sing (and act) in a new way, straightforwardly, almost casually. This goes well with the new sonic naturalism of the scenery; indeed, it's a necessity. The soloists fit into the surrounding stereo with entire ease and naturalness. As for the chorus, sailors and cousins-and-aunts, it positively bounces with eagerness, a very pro sound but with the enthusiasm of a high school glee club. The Philharmonic is 'way ahead of the old theater orchestras we used to get. And the dialog! It's there at length (not the short, stilted excerpts common in earlier recordings) and put to superb effect—preposterous, but ever so human. At last, the spoken element catches up with the music.

In all truth, I say, this is the dawn of a new life for G & S, assuming that the series continues. It had better. Live performers: You'd better study this one too. Lots of new ideas.



From its Sequential Cam System that antiquates the conventional noisy cam gear and swinging plate to its Synchronous Power Unit, the BSR McDonald 810 is designed to match or exceed the performance of any automatic turntable currently available ♦ Some other highlights include a Variable Pitch Control ♦ A 12" dynamically balanced turntable platter ♦ A viscous-damped cue and pause control with exclusive friction Cue Clutch to keep the tone arm cued over the exact groove ♦ An automatic tone arm lock to eliminate accidental damage to the stylus or record ♦ A Concentric Gimbal Arm Mount and featherweight push-button operation featuring the widest selection of operating modes ♦ Your BSR McDonald dealer will be happy to audition the 810 for you ♦

The price for this unbelievable performer? \$149.50 ♦ From BSR ♦ The world's largest manufacturer of automatic turntables ♦



BSR (USA) Ltd.
Blauvelt, N. Y. 10913

Introducing the BSR McDonald 810 Transcription Series Automatic Turntable.

Check No. 59 on Reader Service Card

(Note an earlier London D'Oyly Carte series also done with the Royal Philharmonic. This new series is clearly marked Phase 4 stereo, and has a different conductor. There is a single disc of excerpts. Buy the whole two-record show. Decidedly.)

Performance: A Sound: A

Ballet

Tchaikovsky's Greatest Ballets. (Nutcracker/Swan Lake Suites) Boston Pops, Fiedler. **RCA LSC 4002**, stereo, \$5.98.

Evenings at the Ballet. (Les Sylphides, Carnaval, Sylvia, Coppélia, Giselle). Philharmonia Orch., Robert Irving. **Seraphim SIC 6069 (3)**, stereo, \$8.94.

Ballet music is excellent reissue material. Its message is essentially entertainment—that is, background for the visible dance on the stage—and it makes equally good high-level background music for all sorts of other activities, unenvisioned by Tchaikovsky et al. So what if the recordings are some years old, and maybe not super hi-fi? I listened to Les Sylphides as background for cooking up a huge spaghetti meal one night; Schumann's Carnival took me straight through the eating of the same, with pleasurable results. And so it goes.

Price differentials these days are outrageously hardboiled. Sales curves, fame-charts, appearances, where & when—that's what counts, not the music, not the fi nor the performance. You will note that the Boston Pops, which RCA no longer records, still commands top pricing, maybe because it always has and the legend must be preserved, or maybe just to meet the present competition in Boston (Deutsche Grammophon). The Boston Pops Tchaikovsky is of the expected warm, somewhat unbuttoned sort, not very high voltage and good for spring beer drinking. The sound is perfectly OK but not really top fi by present standards. Don't ask me to figure when it was recorded. On Seraphim the date is implied by the Orchestra, which became the New Philharmonic 'way back. The Angel sound, whatever the date, seems cleaner and smoother to me, and the interpretations with Irving are top dance stuff, tighter, more precise more expressive than the Boston efforts. To be expected; Irving is an experienced conductor of live ballet. But this album goes at half price! It's a bargain, decidedly. Better music, better sound than on RCA.

Performances: B, A- Sound: B-, B

ONLY FOR Music Lovers



Doesn't matter what kind of music you love. There's lots you want to know. Like what's available in the stores — on records and tapes — the new releases, the oldies, the revivals, everything.

There's only one authoritative source, recognized by record companies, musicians, librarians. It's Schwann.

Schwann is thorough and accurate. Contains everything from composers' names to list prices. Distributed through record/tape dealers only. But some stores are funny. They forget to order enough, and a few even chain their Schwanns to the counter!

So if your favorite store doesn't have Schwann, use the coupon below to tell us who he is and to get acquainted with the treasury of information you'll find in Schwann.

Schwann-1 Monthly. Special new listing section has latest releases: records, 8-track cartridge and cassette tapes. Nearly 45,000 total listings in classical, recent popular, rock, jazz, musical shows, opera, ballet, electronic, quadrasonic, etc.



Schwann-2 Semi-annual supplement. Expands coverage of Schwann-1 in specialized categories: pop more than two years old, classic jazz older and re-released mono and reprocessed stereo classical recordings, classical on lesser-known labels, international pop & folk on domestic labels, spoken, educational, religious, etc.



SPECIAL PRICE SAMPLE OFFER

If your favorite store doesn't carry Schwann, order samples by mail. Prices include postage and handling.

- Schwann Sampler: one Schwann-1 (monthly) and one Schwann-2 (semi-annual)\$2.00
- Latest Schwann-1 (monthly)\$1.25
- Latest Schwann-2 (semi-annual)\$1.00

I enclose \$_____ for the items checked above.

Name _____

Address _____

City _____ State _____ Zip _____

Favorite music store _____

Schwann Record & Tape Guide

137 Newbury Street, Boston, Mass. 02116

AU

Canby's Capsules

Edward Tatnall Canby

Igor Stravinsky—the Composer as Pianist. (1930-34). With Samuel Dushkin, vl., Concerts Straram, Ansermet. **Seraphim 60183**, mono, \$2.95.

Stravinsky conducts Music for Chamber and Jazz Ensembles. Columbia Jazz Combo, Chamber Ensemble. **Columbia M 30579**, stereo, \$5.98.

Britten: Serenade for Tenor, Horn & Strings (1943); Les Illuminations (1939). Robert Tear, Heather Harper; Alan Civil, horn; Northern Sinfonia, Marriner. **Angel S-36788**, stereo, \$5.98.

Schubert: Music for the Theatre (Rosamunde; Magic Harp). Lucia Popp, sopr., Orch. Cho. of Naples, Vaughan. **RCA Victrola VICS 1638**, stereo, \$2.98.

Tennyson. Record Two. Read by Frank Duncan, Michael Hordern, David King. **Argo PLP 1046**, mono, \$5.95.

Beethoven: Ode to Joy. (Choral Finale Ninth Symphony; Choral Fantasia, Op. 80.) Soloists, Philharmonia, New Philharmonia Orch & Chorus, John Aldis Choir, Klemperer. **Angel S-36815**, stereo, \$5.98.

Chansons der Troubadours. Studio der frühen Musik. **Telefunken SAWT 9567-B**, stereo, \$5.95.

Mozart: Klavierkonzert Es-dur KV271; B-dur KV595. Rudolf Buchbinder; Warschauer Kammerorchester, Teutsch. **Telefunken SLT 43 125-B**, stereo, \$5.95.

Mozart Symphonies (No. 35 "Haffner"; No. 28 in C). New Philharmonia, Ozawa. **RCA Victrola VICS 1630**, stereo, \$2.98.

Landowska Plays Bach. Landowska Plays Bach—Vol. II. **RCA Victrola VIC 1594, 1634**, mono, \$2.98 ea.

Landowska at the Piano/Mozart/Haydn **RCA Victrola VIC 1535**, mono, \$2.98.

Four old 78 recordings, two of them ultra-familiar to my long-remembering ears, as (I think) old Columbia albums. The *Serenade in A* (1925) for four 10-inch sides, a gentle newcomer, the *Duo Concertant* with violin, an acidly lovely work of the Bach-rhythm period, the *Capriccio*, with orchestra, even more acid but beautifully played—and the brief piano rag music. Ultra-dead French recording, minus highs but otherwise good for the time. An expert pianist, meticulously accurate in his own music.

Stravinsky was one of earliest "classical" men to experiment with 20th C. pop idioms—note the pre-jazz Ragtime music of 1918, the jazzy Octet of 1922, *Praeludium* 1936/37, *Ebony Concerto* 1945, all in a sparse, dessicated but most rewarding semi-jazz style. These & more on this disc. Remarkable how superior is *this* *Ebony Concerto* to Woody Herman's (1946) original 78 floundering! He got more than he'd commissioned for.

Two excellent performances of the memorable Britten songcycles. The *Serenade* is virtually a re-creation of Peter Pears' famed 1948 recording of the 1940s—Tear must have studied it. (Pears' later LP is much inferior.) *Les Illuminations*, often sung by Pears, was originally for soprano—Harper is superb. Grand ambience, good via matrix ("quadrio") systems.

A usefully comprehensive collection of all the tuneful Schubert music written for these two plays, incl. the so-called "Rosamunde" overture, actually from the *Magic Harp*. Italian performance is a bit thin, the slow tempi very slow; Popp is lovely in one solo, the chorus sings an indeterminable language in several numbers. Vienna—or England—would give it all a higher voltage.

If you studied "Lady of Shalott"—or "The Light Brigade"—in English class, these readings will fascinate you. Three well contrasted British voices do a listenable job on a cross section of early and late T.

Interesting idea for a partial repackaging: the last movement of the Ninth and the parallel and strikingly similar (though far less developed) *Choral Fantasia*, performed 16 years earlier. Both are led by the magisterial Klemperer, with Daniel Barenboim at the piano in the Op. 80. Those who know the Ninth will be astonished.

A pleasure to hear these early secular court songs done with imagination, musical feeling *and* expert scholarship! They really "come alive"—at last. Accompaniments on old instruments of the period.

Two Mozart piano concerti (Bb, Eb) from Warsaw with a young Viennese genius-pianist—inexplicably, the dullest Mozart I've heard for years. Cranked out, note-perfect, expressionless. My guess: the Polish orch. is basically at fault, the pianist perhaps just bored.

A prime orch. and a prime conductor—half price. So much the better! Mystery of the economic scene. No. 28 is excellent; the thicker-textured "Haffner" is rushed and sounds unrehearsed—not enough "breath" for the hard-pressed string players. But the sense is there, and the life.

The RCA Landowska recordings, made in her home near the end of her life, will go on & on—here are the latest reissues, low-price. The harpischord Bach, on her French instrument, is wiry in sound, thickly registered and close-miked but the magnificent performances, already old fashioned, get through timelessly. Her piano sound is thinnish, pointed, dry; but superb shape and phrasing the music is carried through.

Weingarten Looks At Joan Baez



Sherwood L. Weingarten

JOAN BAEZ doesn't quit. She doesn't stop singing like an angel, and she doesn't stop protesting.

Her latest LP, her first for a new label, A&M, is sometimes more subtle than previous efforts. But none of her fans will be disappointed: The anger, the beauty, the disquiet and the serenity—all are present.

Even the cover of the album, **COME FROM THE SHADOWS** (SP 4339), shows the contradictions in the folksinger's life. Its front contains a hopeful photo of two elderly protestors walking hand-in-hand; the opposite half pictures the singer and her dog looking wistfully into the distance. But her liner notes are pretty much the same old song.

Inside the covers, the recording is nearly perfection itself. The folksinger, who also produced the disc and penned half of the dozen tunes, obviously feels very much at home in Nashville, where the vinyl was recorded.

It may surprise even the most jaded listener just how easily she slides from a bitter protest to a country ballad to an art song to a wistful dream. But it should come as no surprise whatsoever that her writing has matured, mellowed somewhat into a framework in which the words are softer even when they are barbed.

Always, though, when the inequities of the system are attacked, she seems to care the most. As in "Prison Trilogy (Billy Rose)," wherein she suggests we the people raze the prisons because they are doing more harm than good. As in "Song of Bangladesh," wherein she laments the ability to watch people suffer the throes of starvation without doing anything about it.

But the highlight of the LP is John Lennon's "Imagine," a soft-spoken plea for brotherhood, a futuristic day-dream of a time when there truly is peace.

* * *

THE JEWISH AMERICAN PRINCESS (Bell 6063) features Judy Graubart as the JAP, Lou Jacobi as her father, Beatrice Arthur as her mother, and Frank Gallop as narrator. The comedy LP, exaggerated humor but often right on target, spoofs over-protective parents, boy friends who "aren't good enough for her," *in places*, wedding extravaganzas, allergies and excessive emphasis on education.

SOMETHING ELSE (United Artists, UAS-6797) is just what singer Shirley Bassey is. Versatile as all get-out, although usually best on torch stuff, she combines such positive points as good phrasing, superb enunciation, and that intangible "something extra." Just the right touch of jazziness, a la Tony Bennett. Highlights include "Bridge Over Troubled Water," "It's Impossible," "I'd Like to Hate Myself in the Morning," and "Easy Thing to Do."

HARD TIMES (Caedmon, TC 2048) is a two-disc package of taped interviews with Great Depression survivors, some of whom hadn't quite recovered from the economic shockwaves. The poignancy of the voices is more meaningful, even, than the book Studs Turkel created from the interviews. History from those who lived it.

IAN & SYLVIA (Columbia, C 30736) are back again, though on this label for the first time, with country-folk winners, 11 in all. High spots are the five vocal duets, particularly "Last Lonely Eagle," an ecology-minded thing. Stringed arrangements are a help.

CHRISTIAN OF THE WORLD (Roulette, SR-3001) finds Tommy James going it alone, trying to shed his bubble-gum image. The concept LP, which includes the singer's hit single "Draggin' the Line," doesn't quite make it, however.

BORDER LORD (Monument, KZ 31302) shows that *Kris Kristofferson* is going the way of Carole King, starting to repeat musical phrases used in earlier hits. It's especially apparent in "Josie" and "Stagger Mountain Tragedy." Kristofferson still has charisma though, and utilizes his country-pop chords to great advantage. There's a lot of low register stuff on this disc, and a fair share of bluesy material.

BLOOD, SWEAT & TEARS GREATEST HITS (Columbia, KC 31170) truly deserves the title. If you've missed any of the nine-member group's LPs, don't miss this one . . . especially since lead vocalist David Clayton-Thomas has since decided to try it as a soloist. The group, in case anyone doesn't know, combines blues, rock, and jazz. Highlights are "You've Made Me So Very Happy," "Go Down Gamblin'," "Hi-De-Ho," "And When I Die," "Spinning Wheel" and "Lucretia MacEvil," smashes all.

HISTORY OF ERIC CLAPTON (Atco, SD 2-803) is a two-disc package that traces the development of the great rock guitarist. A must for buffs, it features "Layla," "Hideaway," "Sunshine of Your Love" and "Blues Power."

ULULU (Atco, SD 33-382) features *Jessie "Ed" Davis*, an acquired taste who grows on the listener each time around. Sticking to heavy blues, the singer (who accompanies himself on guitar) is outstanding on George Harrison's "Sue Me, Sue You Blues" and fascinating on an updated "Oh Susannah." Leon Russell backs him on "My Captain," Merry Clayton leads the background vocalists.

STATE FARM (A&M, SP 4332) spotlights a protege of Joan Baez, *Jeffrey Shurtleff*. On this debut album recorded in Nashville, Shurtleff, whose voice occasionally includes a touch of tremolo, is highly pleasant and listenable. Kind of like the guy next door. Best are Baez' "Prison Trilogy (Billy Rose)," tunes by Gordon Lightfoot and Jon Prine, and a couple of duets with Baez ("Como Tu," sung in Spanish, and "Hello in There," a moving saga of aged lonely people).

THE "KILLER" ROCKS ON (Mercury, SRM 1-637) combines rock 'n' roll with country as *Jerry Lee Lewis* bangs on the piano and his vocal chords a dozen times. Strings are added, some-

times giving the redone oldies and recent chartbusters an unreal quality. Best are Elvis' "Don't Be Cruel," Joe South's "Games People Play" and "Walk a Mile in My Shoes," Kris Kristofferson's "Me and Bobby McGee," and Fats Domino's "I'm Walkin'."

SORRELLS PICKARD (Decca, DL 7-5338), a guy who backed *Del Reeves* and Ringo Starr, debuts with a melange of tunes dealing mainly with lost loves, pain and faith—typical country stuff.

The singer, a buddy of Kristofferson, has a deep, gutsy folk-country voice that could click.

NATURAL CAUSES (Dunhill, DSX 50115) is a game attempt by newcomer *Richard Landis* to turn his wanderlust into art. It almost works, for Landis, who sings and tinkles on the 88s, has the rough Rod Stewart-like voice that's in these days. The artist composed, in whole or part, all of the 10 tunes.

COVEN (Sunshine Snake-MGM, SE-4801) is the title of both disc and

quintet. Stress is on electric rock, with slight country overtones. It's loud, heavy, noisy and non-innovative. Highlights are a revival of Presley's "Jailhouse Rock" plus "One Tin Solder."

RAINBOW RACE (Columbia, C 30739) is Pete Seeger going strong at 52; still the peacenik and still the talent. There are eight of the singer's own tunes here, plus two others. Highlights are "Last Train to Nuremberg," an anti-war effort about My Lai and the fact that "we are all guilty" and have blood on our hands for the Vietnam atrocities; "Old Devil Time," which notes that change and progress can't be halted, and a ditty taught Seeger by Woody Guthrie in the '40s, "Hobo's Lullaby."

DONNY HATHAWAY LIVE (Atco, SD 33-386), recorded in Hollywood and New York City, includes one cut, "Voices Inside (Everything Is Everything)," that is getting heavy FM air-play despite its 13:40 length. Broken into a "suite," the piece by far is the best thing on the eight-cut album. Hathaway is a soul-singer basically, who plays electric piano, regular piano and organ, and who did all the arrangements for the LP. The main problem is that the sound sometimes is cluttered, sometimes metallic, and audience noise intrudes occasionally.

QUEUES (Uni, 73129) spotlights poetic lyrics and good harmonies as *Vigrass (Paul) & Osborne (Gary)* stick, pretty much, to a middle-of-the-road, soft and smooth pop-rock thing. The two who penned all the lyrics, are backed by 11 instrumentalists (including one on Moog) and a background chorus.

ONE YEAR (Epic, E 30974) finds *Colin Blunstone* on an introspective mind trip. The former *Zombies* vocalist, supported by slick strings and a big band sound, does well with contemporary art-type ditties. He sings softly, almost like a male counterpart to Claudine Longet, but in a more modernistic framework.

WELCOME TO FAT CITY (Paramount, PAS 6028) is country-rock by the Fat City duo, *Taffy Nivert* and *Bill Danoff*. There's good harmony and a smooth sound, even when they're loud; they're best, however, on slow material. Top tune is "Readjustment Blues," dealing with a Vietnam vet who returns stateside to find his country upside down, his values shaken.

WEDNESDAY'S CHILD (Vertigo, VEL 1011) puts *Thomas F. Browne*, singer-drummer, in the limelight. But he shouldn't stay there long, for his lyrics and music are mediocre. The disc is distributed by Mercury, which should know better.



The difference between 400 watts and 100 watts is more than 300 watts.

This is the New Math suggested by the Phase Linear 400 watt RMS Direct Coupled Stereo Power Amplifier. The difference is dramatic — and it's in the listening. You might be startled to hear your stereo deliver the life-size sound of a musical instrument for instance, free from clipping and distortion.

In this regard Julian Hirsch said in *Stereo Review*, "The Phase Linear... was in a class by itself." Hear the 400 at your dealers now—it makes a powerful difference. Price \$499.00

Phase Linear
CORPORATION
405 Howell Way
Edmonds, Washington 98020
206-774-3571

Check No. 62 on Reader Service Card

J. HENRY BURNETT (Uni, 73125) exhibits 10 cuts, eight of which Burnett penned, in whole or part. His scratchy voice, although in vogue, is unimpressive. He is backed by the B-52 Band and The Fabulous Skylarks, neither of which get off the ground.

HALLWAY SYMPHONY (Dunhill, DSX-50113) is a disc by a three-guy trio (Hamilton, Joe Frank and Reynolds) reminiscent of the Crosby, Stills, Nash & Young folk-rock, adding a touch of white soul. It's a good pop sound, ranging from slow to fast, from soft to loud. Highlight is a medley of Paul Simon's "Bridge Over Troubled Water" and Carole King's "You've Got a Friend," entwined so neatly it becomes one integrated song.

WRITE MY NAME IN THE DUST (Verve Forecast, FTS-3091) is a bummer, for *Peter Bardens* doesn't live up to the promise of earlier material. He penned all nine pieces, produced the LP himself, and plays organ and piano while singing. Nonetheless, it doesn't work, mainly because the electric rock is hampered by excessive sound gimmickry.

HE TOUCHED ME (RCA Victor, LSP-4690) is the latest thrust by *Elvis* into the faith field. There are a dozen religious outings, highlighted by "Amazing Grace" and "Bosom of

Abraham." Presley's unreviewable; if you don't like him by now, you never will.

LOOSE AND FIERY (RCA Victor, LSP-4652) is a sleeper. *Roger Whittaker* has a deep country voice with shadows of Tennessee Ernie Ford and Perry Como gone mod. Highlights of this, his fourth LP, are "I Believe," a rip-roarin' gospel-like piece he wrote; "Mammy Blue," a catchy tune that was a smash in Europe; "A Song for Erik," based on Rudyard Kipling's poem "If," and good renditions of "Fire and Rain" and "Scarborough Fair." He could easily become a dream boy for middle-aged matrons.

JOHN PRINE (Atlantic, 8296) is in the country-folk-blues bag, singing things that jump musical fences. The 24-year-old newcomer already knows loneliness can be man's heaviest albatross, and he knows war is his strongest foe. So he sings about both, with a voice reminiscent of early Dylan but not quite as rough. Best tune is the anti-war opus, "Your Flag Decal Won't Get You Into Heaven Anymore."

DENNIS STONER (Rare Earth, R530L) has a fascinating voice, usually deep, usually sounding as if his vocal cords have been sandpapered. He does folk-rock in the Dylan tradition, but adds lots more (blues, gospel and

country). He plays guitars, harpsichord, piano and bass. And he performs six of his own melodies on the 10-track disc, distributed by Motown. Highly listenable are "Nightingale," a simple ditty straight out of the folk era; the bluesy "Side Street Woman" and "Maybe Someday/Maybe Never;" "Bastille Day," a combination of rock and gospel; a heady, cookin' version of Neil Young's "Southern Man," and "Riders in the Sky," more soulful than Vaughn Monroe's chestnut.

JULIE BUDD (RCA Victor, LSP-4622), recorded in London, is aided by peppery, slick arrangements by Tony Hatch, who also wrote most of the 11 melodies the singer performs. Highlights include "I Don't Know How to Love Him," "The Long and Winding Road" and "You've Got a Friend," topped off by "Marie de Vere," a throwback to the '20s, and "Call Me," with its typical '60s sound. The thrush is magnificently clear-voiced throughout.

FLAMENCO PURO 'LIVE' (London "Phase 4 Stereo," SP 44172) puts Paco Pena and his group in the limelight on nine cuts that resound with foot-stomping, guitar gymnastics, hand-clapping, high-pitched vocalizing, and chanting—plus lots of applause. It's authentic; it's exciting. **A**

Try this on your violin concerto.



In fact, try our new jam-proof Chromdioxid^(tm) tape cassette on the most demanding performance you can record. A bravura solo. A soaring aria. A brass choir. Listen carefully to the transients and high frequency overtones. Then replay it and hear for yourself the increased output and incredible clarity of this exceptional tape . . . particularly in the treble response.

Combined with the new and exclusive SM* jam-proof mechanism that prevents sticking, eliminates wow and flutter, this new low-noise, high-output tape gives you a fidelity and dynamic range unlike anything you've ever heard before. See your dealer or write BASF Systems, Inc., Bedford, Mass. 01730



*Special Mechanics, patent applied for

Jazz & Blues

Martha Sanders Gilmore

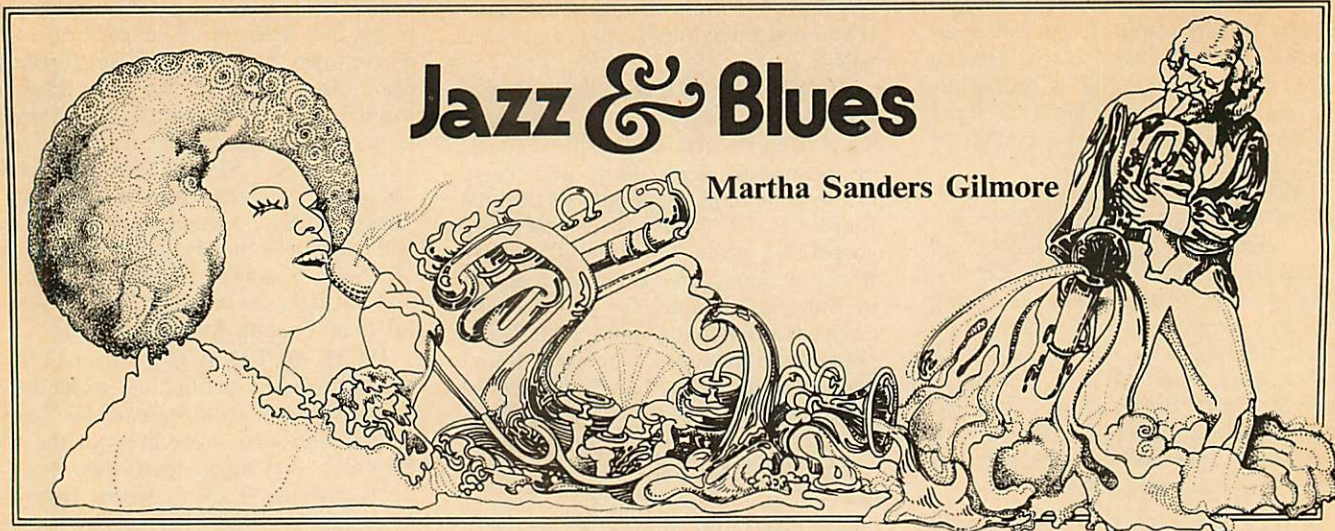

Cal Tjader: "Tjader."

Musicians: Cal Tjader, vibes and organ; Al Zulaica, pianos; Michael Smithe, congas; Jim McCabe, bass; Dick Berk, drums; John Rac, tambourine; "Coke" Escovedo, timables; Pete Escovedo, congas; John Coppola, trumpet; Bill Atwood, trumpet; Bill Powers, trumpet; Gordon Messick, trombone, and Robert Ferreira, flute.

Songs: I Showed Them; Wear Your Love Like Heaven; First There Is A Mountain; What Are You Doing The Rest Of Your Life; Fresh Air; You Keep Me Hangin' On; She's Leavin' Home; Evil Ways, and Mambero.

Fantasy 8406, stereo, \$4.98.

Cal Tjader and his dapper dozen have released a captivating and extremely lively album here that lingers at the surface of the musical curve without ever dipping Down Under to seek further musical complexities. But no matter. It is just good fun, exotic with jungle effects and rocking-chair door-squeaks, percussive bird noises, quacks, and zebra brays. The rather superb audio is finished off by an excellent remix job on the part of Marty Cohn. Tjader's vibes emerge crisp and clear as bells, the supporting instruments distinct and at good distances one from the other. Only the four-piece brass section—three trumpets and a trombone—sounds a bit thin and in want of proximity to the mike although it is used purely antiphonally and as a barking commentary in the manner of Herb Alpert.

Tjader may have *heard* Blood, Sweat, and Tears or Chase judging from his tight, imaginative arrangements of tunes of the seventies, though he has superimposed the light and lively Latin

temperament for which he has become famous since his days with Brubeck and Shearing.

Tjader is out of the Martin Denny, Arthur Lyman, Walter Wanderley school which bridges the gap between jazz and the popular song, a mutual adaptation that blends them into a not-bland combination.

Tjader projects a bright green sound, full as a meadow. Carefully rehearsed and constructed, the album explodes with potential chart-busting singles, a concession to modern times in music, by Donovan, Lennon-McCartney, Holland-Dozier-Holland, Tjader himself, and the filmy Michel Legrand. The latter's "What Are You Doing the Rest Of Your Life?" is an aching beauty, Tjader lending it ballad treatment and achieving a vast realm of sound while creating winsome sonorities. A "MacArthur Park" insertion toward the end is a good choice.

The work of Al Zulaica on acoustic and electric pianos deserves high marks throughout the LP. He and Tjader are the prime soloists, Tjader doubling up on organ at times and submitting to an overdubbing prognosis. There is always something going on—a kind of perpetual motion. The music is highly rhythmic, breathlessly mobile, "Fresh Air" being a cardinal example and immediately recognizable. The drums surround us in the best of this easily understood but successful genre.

The Beatles' "She's Leaving Home" is melancholy and songful, containing some unexpected intervals. Interesting to hear what they do with it.

An intoxicating album, it would be great for a party—if you like music at a party! And, if you don't already know,

there's nothing like vibes in the morning. In fact, they aren't even so bad at the end of the day.

Sound: A Performance: B Pleasant!

Hound Dog Taylor and The House Rockers

Musicians: Hound Dog Taylor, lead guitar and vocals; Brewer Phillips, second guitar, and Ted Harvey, drums.

Songs: She's Gone; Walking The Ceiling; Held My Baby Last Night; Taylor's Rock; It's Alright; Phillip's Theme; Wild About You, Baby; I Just Can't Make It; It Hurts Me Too; 44 Blues; Give Me Back My Wig, and 55th Street Boogie.

Alligator 4701, stereo, \$6.00.

Hound Dog Taylor and the House Rockers play in small neighborhood blues clubs in Chicago's south and west sides and are for the most part only locally known. They are among the bluesmen who migrated up to Chicago from the south of Mississippi and are attempting to dispel their blues by singing them. Hound Dog has released only two 45's to date but toured Europe with the American Folk Blues Festival and appeared at the 1970 Ann Arbor Blues Festival.

There are 12 cuts, most written by Theodore Roosevelt Taylor, alias Hound Dog, and a couple by his friend and mentor Elmore James with whom he has been compared from time to time. By and large, it's raw, rocking-horse boogie, with the instrumentals outshining the vocals. Hound Dog's voice has difficulty penetrating over the vigorous sounds of his sidemen who include Brewer Phillips on second

guitar and Ted Harvey, who got his start in the Fifth Army Band, on drums. It would appear that Harvey, initially a jazz drummer and highly rhythmic, would be more at home in that context.

Although these rather obscure blues people deserve exposure outside the Chicago area, the album suffers from a sameness—one's interest is not held as it might be if you were listening to them in a small club. The music is predictable and at times dull and unoriginal. Traces of Jimmy Reed and Bo Diddley lurk in Hound Dog's intonations as he slurs word endings but his bottleneck guitar work is a blaze of noise—abrasive, uninspired, rivetted with electricity, and somewhat cacophonous.

Guitarist Brewer Phillips comes through a bit better, particularly in "44 Blues," one of the LP's most successful tracks on which Phillips and Hound Dog complement one another texturally. Honorable mention goes to "Taylor's Rock," a together jail house rock of a tune delivered with fire and to "It's Alright," a mid-tempo boogie with an unexpectedly attractive flattened third in the bass line. Hound Dog vents his humor in "Give Me Back My Wig," definitely in a hurry to get his wig back!

The audio leaves something to be desired as well; it is of a rough, uneven, and swampy grain. However, rock exponents might learn a few things from this threesome—from Hound Dog's blistering waspish attack superimposed upon a concrete, sandbag masonry.

As Alligator is a new independent label with limited distribution, this recording may be ordered for \$5.00 postpaid (\$6.00 outside U.S.) from: Alligator Records, Box 11751, Ft. Dearborn Station, Chicago, Illinois 60611. Better still, seek them out weekends in the Windy City at the Expressway Lounge on 55th Street.

Sound: C+ Performance: C+

Jerry Lee Lewis: *Monsters*. Sun 124, stereo, \$4.98.

Sadly, Jerry Lee Lewis' album "Monsters" is all the name implies—a superficial and slick trip in nostalgia back to the rhythm and blues and boogie-based Nashville sound of the fifties. It has the ring of a take-off on Elvis complete with breathy, suggestive, slurred words and raunchy note-shy utterances or power cum popularity gained by insinuation. The audio is predictably phoney and enmeshed in echo. Lewis accompanies himself on

**When you make the finest
tape recorders,
you've got to make the
finest tape recorder
accessories - Sony.**

Right? Right!

SONY SUPERSCOPE
You never heard it so good.®

Check No. 63 on Reader Service Card



**#1 SOUND
#1 COMFORT**

Clark/Stereophones...
The ultimate in performance and comfort.

Send for literature on all our models.



David Clark COMPANY
INCORPORATED

360 Franklin St., Worcester, Mass., 01604

WEST COAST OFFICE: 1696 Centinela, Suite 2., Inglewood, Calif. 90302

Check No. 65 on Reader Service Card

MODEL 100A

The Kleen Machine.

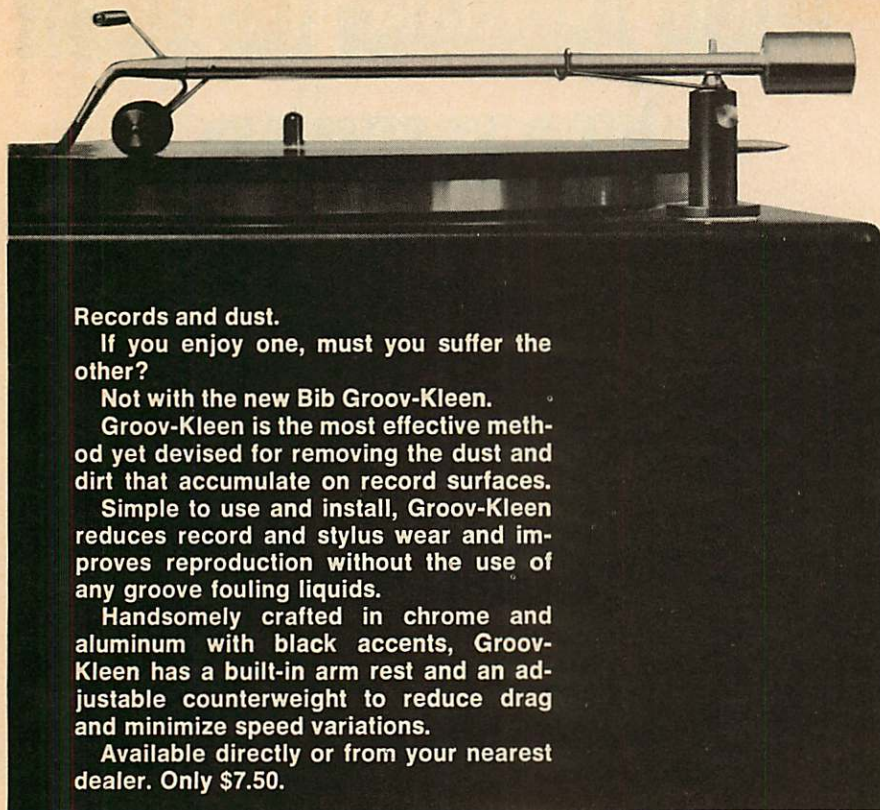

Records and dust.

If you enjoy one, must you suffer the other?

Not with the new Bib Groov-Kleen.

Groov-Kleen is the most effective method yet devised for removing the dust and dirt that accumulate on record surfaces.

Simple to use and install, Groov-Kleen reduces record and stylus wear and improves reproduction without the use of any groove fouling liquids.

Handsomely crafted in chrome and aluminum with black accents, Groov-Kleen has a built-in arm rest and an adjustable counterweight to reduce drag and minimize speed variations.

Available directly or from your nearest dealer. Only \$7.50.

Revox Corporation 155 Michael Drive, Syosset, N.Y. 11791
Check No. 52 on Reader Service Card

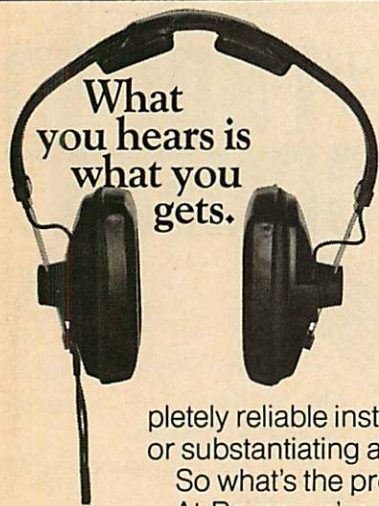

What
you hears is
what you
gets.

When you stop to think about it, the claims made for some headphones seem to border on the ridiculous.

You've read about phones that supposedly go from the subsonic to the ultrasonic, some that employ woofers, tweeters and crossover networks and still others that are tested on and certified by dummies.

But the truth is that there is no completely reliable instrument method for testing headphones or substantiating a manufacturer's performance claims.

So what's the prospective headphone buyer to do?

At Beyer, we've found the only reliable answer is

to trust your own ears.

And to help make it easier for you, we've reprinted an independent, completely unbiased article called, "The Truth About Headphones," which we'll be happy to send you. It describes the difficulties involved in testing headphones and goes on to tell you how to compare and evaluate headphone performance for yourself.

Once you've had a chance to compare Beyer to the rest, we think you'll end up buying Beyer.

Because, the truth about Beyer headphones is...what you hears is what you gets.

Revox Corporation, 155 Michael Drive, Syosset, New York 11791
Check No. 66 on Reader Service Card

piano in a style that is immediately recognizable by its scrambling descending runs to the bottom of the keyboard and boogie-woogie barroom piano rolls. However, it is fun to hear again such numbers as "Save The Last Dance For Me," "Pink Pedal Pushers," "Drinking Wine Spo-Dee-O-Dee," and the incredibly earthy "Honey Hush" down to its last "Hyoh Silver!"

El Curo: *Flamenco*. Audiophile AP 106, stereo, \$5.95.

This fulsome collection of flamenco leaves one utterly gasping over what artist El Curro attempts. For an inspired introduction to flamenco or for seasoned fanciers of that melancholy gypsy and Spanish music that lies midway between folk and "art" music, this attractively packaged LP is highly recommended. Audiophile assesses El Curro, who grew up in San Antonio's West Side, as "the greatest American-born flamenco guitarist in the world" and his dexterity at noting, strumming, and using his guitar as a tom-tom is astonishing. And in a repetitious music with a narrow range, a music that doesn't stray far beyond its keynote, El Curro achieves considerable variety in material, meter, and dynamics. Each example has its own personality and mood. El Curro combines percussive attacks with melodic insertions, his melody emerging out of his expressive ornamentation, gentle yet fiery in such particularly moving examples as "Yaqui" incorporating Indian intervals, "Medias Granadinas," and "Zambra-Gitana," all of more than routine interest. The recording is all the more enhanced by its lucid sound and in-obtrusive engineering.

The becoming of Jazz: 1899-1922

Arnold Bopp, Klosbachstrasse 45, CH 8032 Zurich, Switzerland. Three four-track tapes, 7½ ips, 1800 ft. polyester, \$84.00.

This is a unique collection composed of approximately 200 original recordings chronologically arranged. Included are Ted Lewis, Ben Selvin, Mamie Smith, Bert Williams, Paul Whiteman, Vincent Lopez, Fats Waller, and many others. Two versions of the Maple Leaf Rag are included; one by the Ossman-Dudley Orchestra and one from a piano roll cut by Scott Joplin. Write to Arnold Bopp at the above address for further information or to order. **Æ**

Classified

Rates: 25¢ per word per insertion for noncommercial advertisements; 50¢ per word for commercial advertisements. Frequency discounts as follows: 3 times, less 10%; 6 times, less 15%; 12 times, less 20%. Closing date is the FIRST of the second month preceding the date of issue. *Payment must accompany all orders under \$10.00.* Use the handy self-addressed, postage paid card at the back of this issue. When replying to AUDIO box number ads, send letters c/o AUDIO, 134 No. 13th St., Phila., Pa. 19107.

FOR SALE

WORLD'S LARGEST, DEEPEST, MOST POWERFUL SUB WOOFER SYSTEM can be had only at Music and Sound Ltd., 413 Johnson St., Jenkintown, Penna. 19046 215/885-4214. From \$1,000.

YOUR RABCO SL-8E SOUNDS BETTER THAN YOUR SL-8E!! For \$100 we'll convert "yours" to "ours". Professional Products Div., Music and Sound Ltd., 413 Johnson St., Jenkintown, Penna. 19046 215/885-4214.

SEND FOR LATEST STUDIO CLEARANCE sale list featuring microphones, tape recorders, equalizers, limiters, turntables, lathes, cutter heads, loudspeakers, mixing consoles, organs, and pianos. Only professional studio equipment listed. Wiegand Audio Laboratories, RD #3, Middlesburg, Pa. 17842 (717) 837-1444.

FREE TECHNICAL ASSISTANCE + ACOUSTICAL CONSULTATION with purchase of individually hand picked, guaranteed lab tested and aligned custom components from Audio Research Corp., A.K.G., Beyer, Crown, Decca, Gately, I.M.F., Infinity, JBL PROFESSIONAL, Otari, Quad, Rabco, Revox, Rogers, B.B.C. Monitor, SAE, Sound Systems International, Stax, Tandberg, Transtatic. We save you \$\$\$ with **FACSIMILE REPRODUCTION** at Music and Sound Ltd., 413 Johnson Street, Jenkintown, Penna. 19046 (215) 885-4214. Engineers, College Instructors, Musicians.

WORLD'S FINEST SPEAKERS—on demonstration—Audio Research 4 x 6 panels. Infinity SS1 (improved version), 8 Quad system, B&W 70's, trans static speakers, inquiries invited. Paul Heath, 81 Big Tree St., Livonia, N.Y. 14487, (716) 346-5630.

GET "MUSIC ONLY" FM Programs SCA Adaptor fits any FM tuner or receiver. Free list of Stations with order. Kit \$14.50 (with Squelch \$19.50) Wired and Tested \$25.00 (with Squelch \$29.95) All plus postage & insurance. Thousands Sold. SWTPC, Box 32040A, San Antonio, Texas 78284.

SCOTCH MAGNETIC TAPE, discount Box 167A, Orwigsburg, Pa.

HI FI FURNITURE? See Toujay Designs at SEE 70, Hi Fi Expo, 443-A, Park Ave. S., NYC, 10016, Tues. to Fri. 11-5, Sat 11-4. Full line brochure 25¢.

TAKE SOUND-OFF your Cassette or Cartridges with "ERASSETTE"—our exclusive Electronic Wash (-65db O-VU) gives you a like new Cassette or Cartridge in an instant. Less than 1-lb, self-contained, 4-"AA" battery powered. Send \$12.50 (5% sales tax CA Res.) Postpaid. MAGNESONICS CORP. P.O. 127, Northridge, CA 91324.

AUDIO RESEARCH DUAL 50FIB POWER AMPLIFIER. One MONTH OLD. MINT CONDITION. LIST: \$650.00, Sell for \$475.00. Reply to Box AAUG2-2

FOR SALE

HI-FI DISCOUNTS. Free catalog—Western Electronics, 7121 Rich Ave., Newark, Calif. 94560

CONDENSER MICROPHONES in easy to build kits. Free details. Write Electronic Enterprises, 3305 Pestana Way, Livermore, Calif. 94550.

FREE 64 PAGE CATALOG offers hundreds of recordings of rare renaissance, baroque and classical music. Some records priced as low as \$1.00 each! All late recordings. In stereo only. Musical Heritage Society, Box 932-AU, New York, N.Y. 10023.

HEAVY DUTY 12" ANTI-STATIC TURNTABLE MAT. \$4.95 postpaid. Creighton Audio labs, 740 Haven Pl., Linden, N.J. 07036.

SOUND SYSTEM INTERNATIONAL presents a revolutionary radial track tone arm and turntable. Brochures available. Paul Heath, 81 Big Tree St., Livonia, N.Y. 14487 (716) 346-5630.

OPERA TAPES—Records "live" performances, broadcasts. Free catalog. Hathaway, 49 Merbrook Lane, Merion, Pa. 19066.

SHURE V15-11 improved, \$47 and old cartridge. shipped prepaid. STEREO SHOP, 1209 1st Ave. SE, Cedar Rapids, Iowa 52402.

LEARN WHILE ASLEEP. Hypnotize with your recorder, phonol! Astonishing details, strange catalog 10¢. Sleep-Learning Association, Box 24-AZ, Olympia, Washington.

"OVERSEAS MUSIC & NEWS Hallicrafters S-240 shortwave receiver w/tuner output \$99.95 ppd USA AMRAD 1025 Harrison St., Oakland, Ca. 94607"

LOUDSPEAKER KITS, complete or cabinet only, original and published designs. Amplifier kits. Factory direct at great savings. Catalog 25¢. R.C.S. Co., P.O. Box 30312, Santa Barbara, Cal. 93105.

ACOUSTIC SUSPENSION SPEAKER KITS. Build your own . . . Save. 10¢. AudioCessories, 320 W. Edmonston, Rockville, Maryland. 20852.

IMF STUDIOS speakers in excellent condition asking \$450 or best offer. Michael Stiuso 69 High St., Eatontown, New Jersey 07724 (201) 542-6705

ORGAN OWNERS & BUILDERS GET THE FACTS about Electronic and Pipe Organs, kits and accessories. Send \$2.25 for new book—"ORGAN BUILDING FOR FUN AND PROFIT." by Robert L. Eby. FREE Parts Catalog included. Newport Organs, Dept. A, 846 Production Pl., Newport Beach, Ca. 92660.

FREE 4-TRACK Stereo Tapes, 8-Track Cartridge, Cassette. Write Music, Box 27815, Los Angeles, Calif. 90027.

JBL Paragon, used three months, \$1,800.00. Also Sony C500 mic never used, \$275.00. Write 7149 Rockford Street, Kalamazoo, Michigan 49002.

What Does So. California Have To Do With Speakers?

For a little over two years **ROGERSOUND LABS** has been selling speakers factory-direct in So. Calif. We have grown to be the largest local manufacturer with the best reputation. Why?

We sell some of the finest speakers you can buy factory direct saving you half. Find out why the studios, musicians and engineers choose RSL speakers. For full info, write or call:



Rogersound Laboratories

(more speaker for your \$ than you'd ever dream possible)

5706 Lankershim Blvd.
No. Hollywood, Calif. 91601
(213) 877-1420 763-0855
Check No. 67 on Reader Service Card

check with the
East-Coast Stereo
Discounters...
...then BUY from

**MIDWEST
HI-FI
WHOLESALE**

Box 567
Ellsworth Industrial Park
Downers Grove, Ill. 60515
312/852-5885

Write for our new
WHOLESALE price list
& catalog. You'll
be glad you did!

**OVER 50 NAME BRANDS
FACTORY - SEALED CARTONS
WHOLESALE PRICES
• SAVE ON TIME
& FREIGHT CHARGES**

Check No. 68 on Reader Service Card

FOR SALE

NATIONALLY advertised Audio Equipment, Cost Plus 10%. Stereo World, 3250 Duke Street, Alexandria, Virginia 22314.

PROTECT YOUR RECORDS. Cardboard replacement covers, plastic lined sleeves, 78 and 45, heavy sleeves, hinged record set boxes, 12", 10", 7". Cabco, A-2, 89 East Woodruff, Columbus, Ohio 43201.

THE FINEST STEREO SOUNDS—On demonstration, Audio Research's Magneplanar speakers and Dual 75 amplifier, QUAD ESL's, Infinity, Stax, Decca, Transcripator, Thorens, Revox—D S Audio, 410 East Evergreen Road, Lebanon, Pennsylvania 17042 (717) 273-6314.

WHOLESALE! Professional Amplifiers, PA Systems, Guitars. Free Catalog. Carvin, Escondido, Calif. 92029.

TUBES "Oldies", latest. Lists free. Steinmetz, 7519-A Maplewood, Hammond, Indiana 46324.

AMPEX PRO TAPE by the carton. Send for prices. BKM Associates. Box 22 Wilmington, Mass. 01887.

BARCUS BERRY transducers for acoustic guitars, pianos, banjos, violins, and other stringed instruments.

- Amplify your acoustic guitar to sound like an acoustic guitar, with total isolation from noise.
- The smallest pianos give big sound through sound systems on your club dates.
- A valuable tool for recording where acoustics are less than optimum.
- Hi/lo impedance outputs from matching preamplifiers to music amps, tape recorders, and studio consoles.

Write or call: CATH-MAR RECORDING SERVICE
17113 Cambridge
Allen Park, Michigan 48101
(313) 278-2278

INFINITY SERVO STATIC one speaker system. Four (4) screens. Original "R.T.R." midrange modules. Walnut Finish (extra screens in rosewood). \$1,500. (414) 961-0184. John W. Clark.

SCOTCH TAPE AT DEALER PRICES. Send for Price List. Federated Electronics Inc., 11824 W. Olympic Blvd., Los Angeles Ca. 90064.

SCHOEPS CMT-56 MICROPHONES—demonstrators. Three pattern type. Cardioid, Bidirectional, Omnidirectional, +48 volt powering \$275 (cost new \$377.) Gately Electronics 215-446-1415.

BUY DIRECT FROM ENGLAND'S HI-FI MAIL ORDER SPECIALISTS! Save on SME. Leak. Goldring, Decca. Tandberg. Revox. Gold Speakers. Garrard. Wharfedale. KEF. Celestion. Transcripators. Cambridge etc. Insured shipping quotes free or send \$2.00 bills for catalog (\$4.00 air post) credited on first purchase over \$100. Goodwin Ltd. 7 Broadway, Woodgreen, London N22. Visitors welcome to showrooms.

MARANTZ 10B Later model custom cabinet \$750.00 1-503-282-9264

AUDIO RESEARCH, Radford, Quad, Decca, Infinity Trans-static, JBL, Braun, etc. Information available. Hartley Electronics, 2115 Symons, Richland WA. 99352, (509) 947-5026 after 5pm weekdays, allday, weekends.

ENGLAND'S LEADING MAIL ORDER AND DISCOUNT SPECIALIST OFFER:—SME IMF RADFORD QUAD TANNOY B & W TEAC KEF DUAL SANSUI AT VERY COMPETITIVE PRICE. PLEASE SEND FOR QUOTES. REPLY BY AIRMAIL. SHIPPED IMMEDIATELY. FREIGHT COLLECT. SOUTHERN AUDIO SERVICES LTD. 43, HIGH STREET, KINGSTON-ON-THAMES, SURREY.

FOR SALE

BASF, MEMOREX, SCOTCH reels, cassettes, 8-tracks. Lowest prices. Satisfaction guaranteed. S&S Audio, Box 2065, Champaign, Ill. 61820.

PROTECT YOUR LPS. Poly sleeves for jackets 5¢ Inner sleeves 4¢ Poly lined paper sleeves 10¢ White jackets 25¢ Postage \$1.00 House of Records, Hillburn, N.Y. 10931.

BRAINWAVE FEEDBACK. Electroencephalophone teaches alphawave control. J & J Enterprises. 24120 A 3rd West, Bothell, Wash. 98011.

WIRED, SELF-POWERED background music adaptor to use with your present FM—\$25.00. Thieves Warehouse, P.O. Box 8057, Pensacola, Florida 32505.

KLIPSCH, TANNOY, JBL, MARANTZ, THORENS, RABCO. No discounting. Superior Sound. 2780 Erie Boulevard East, Syracuse, New York 13224.

NAB HUB ADAPTERS—Fit Revox, Crown, TEAC, Roberts. \$3/pair postpaid. No C.O.D. Quantity prices available. John Kountz, 1065 Van Dyke Dr., Laguna Beach, Calif. 92651.

ATTENTION MIDWEST AUDIOPHILES—hear the Hegeman speaker, JansZen Electrostatics, Braun TG1000, and more, by appointment. Audiophile Systems, 851 West 44th, Indianapolis, Indiana 46208 (317) 283-5404

CURRENT 8-TRACK STEREO TAPES for only \$3.99. Send for your free Catalog today. Reply to Box AJUL2-2

FCC "TESTS-ANSWERS" . . . Original exam manual for F.C.C. First and Second Class License. —plus— "Self-Study Ability Test." Proven! \$9.95. Satisfaction Guaranteed. Command, Box 26348-L, San Francisco 94126.

PHASE LINEAR model 700, \$779.00. Sent postpaid. DTR Sound, 2575 Main, Littleton, Colorado 80120.

TV & RADIO TUBES 36¢ EA. Free 48 page Color Catalog Cornell 4215 A University. San Diego, California 92105.

"PERFECTIONISTS" and discerning people can now get the amplifier that's "wiping out" all other amplifiers at test clinics across the country and is better than test equipment! Kit only \$60. Send for Free Catalog SWTPC, Box 32040B, San Antonio, Texas 78284.

SCOTCH RECORDING TAPE, lowest prices. TAPE CENTER, Box 4305B, Washington, D.C. 20012.

B&W 70CA, PHASE LINEAR, THE WORLD'S FINEST SPEAKER AMPLIFIER COMBINATION. JVC 5011 super preamp. Transcripator, EPI Tower, Quad, Electrostatic specialists. Finest, best equipped laboratory in the country. Formerly supplying to professionals only. Now you can benefit from the unique services of THE AUDIO-LAB, 146 French St., New Brunswick, N.J. 08901 (201) 249-9191.

ALPHAPHONE™ headset—brainwave trainer. Free literature. Aquarius Electronics, Box 627-S, Mendocino, Ca. 95460.

QUAD, Radford, Bang & Olufsen Audio components of superb quality for the connoisseur. Audio Imports, 5557 Versaille Dr., Indianapolis, Ind. 46227.

INFINITY AND CROWN SYSTEMS—AKG microphones, UREI limiting. Fairchild equipment, Rabco, more. Finest reproduction possible. Barclay, 503 Haverford Ave., Narbeth, Pa. 215/MO 7-3048.

TUBE Headquarters of World! Send 10¢ for Catalog (tubes, semiconductors, equipment) Barry, 512 Broadway, N.Y.C. 10012.

FOR SALE

ON DEMONSTRATION—Trans-static electrostatic transmissionline monitors, Super Quad speaker system, Audio Research Corp. D-75 amplifier, Phase Linear 700 and 400 amplifiers, Sound System International arm-turnstile combination. Paul Heath, 81 Big Tree St., Livonia, N.Y., 14487 (716) 346-5630.

FREE literature and quotes on Hitachi stereo equipment. Write: Disco Electronics, Inc., P.O. Box 146, Springfield, New Jersey 07081.

RUBBER STAMPS. One line \$1.00. Each additional line 50¢. Good quality. Prompt service. MOYERS, 3037 Montrose, Chicago, Ill. 60618.

STEREO CORNER will sell most major Audio Products at 20% off the advertised list price—Freight pre-paid. Send order with check to: Stereo Corner, 339 Park Ave. So., Winter Park, Fla. 32789. Check will be refunded by return mail if we are unable to fill order.

CAPITOL RECORDING TAPE—Open Reel—Cassettes—8 Track—Discount Prices. FORDHAM RADIO—265 East 149th, Bronx, N.Y. 10451, Dept. T.

RADIO—TV—TUBES WHOLESALE Free List, Quality Distributor's, 920 S. Main, Kokomo, Ind. 46901

ELECTRONIC MUSIC on tape. Send S-AESE For List. Reavis 617 Cleveland Ave. So. Bend, Ind. 46628

SONY 4 chan. R/P Tape head and 4 chan. erase head. Used 20 hrs. \$70 for the pair. CONCERTONE 802 6 head auto rev deck, \$130. SCOTT LT 112B1 tuner w/case \$100. Record/Playback Electronics from VIKING 423, \$60. Reply to Box #AAUG2-1.

Revox 1104 and Advent 100, both excellent condition. \$450.00 S. Sarper, Prescott House, 3-C, Greenwich, CT 06830

SCOTCH TAPE #150, 1800 foot, 7" reel, polyester, \$1.95, postpaid, \$22.50 dozen. (48 at \$1.75) Recorders, cassettes, open reel music tapes (100 page discount catalog 25¢). Saxitone Tape Sales, 1776 Columbia Road, Washington, D.C. 20009.

LOW, LOW, PRICES, on Audio Equipment and Blank Tape. All factory fresh, 1st quality items. Write for FREE CATALOGS to Mr. A, Dept. AMO at SMG DISTRIBUTORS, INC., 46-35 54th Road, Maspeth, N.Y. 11378.

AUDIO RESEARCH, RADFORD, S.A.E., PHASE LINEAR, BRAUN, KLIPSCH HARTLEY, REVOX, B&O, DECCA, others. Custom designed and constructed music reproduction systems. Each component checked and adjusted. Demonstration by appointment. Phone or mail consultations. C.M. Santmire, Audio Consultant, 1340 S.20th St., Lincoln, Nebraska 68502. (402) 477-8469

"McIntosh 1700 \$525, S.A.E. Mark I preamp \$440, Marantz 250 power amp \$425, all nearly new. C.M. Santmire 1340 S. 20th St., Lincoln, Nebraska 68502 (402) 477-8469.

AUDIO RESEARCH, INFINITY, SAE, BRAUN, TRANSCRIPTORS, DECCA, ESS, STAX, QUAD, EPI, and others. THE STEREO SET, 1737 Wisconsin Ave., Washington, D.C. 20007. (202) 338-1493

AUDIO RESEARCH DEMONSTRATION THE STEREO SET
1737 Wisconsin Ave., N.W.
Washington, D.C.

VISITING WASHINGTON D.C.? THE STEREO SET specializes in the world's finest audio equipment. Relax in one of our 3 sound rooms. 1737 Wisconsin Ave., (202) 338-1493.

FOR SALE

Two Altec A-7 Voice of Theater Speaker Systems. 500 Hz X-over and cellular horn. S. Cal. only. Will not ship \$100 each. F. Tack 1369 Londinderry Pl. LA 90069

Infinity Servo Statik one speaker system perfect condition \$1250. John Taylor, Mt. View Lane, Duaneburg, N.Y.

GUITAR AMPLIFIER HARDWARE Write: Pacific Hardware P.O. Box 696 Mukilteo, WA 98275

DAYTON WRIGHT, AUDIO RESEARCH, E.S.S., RADFORD, INFINITY, I.M.F., B&W LTD. QUAD E.P.I., BRAUN, B&O, CITATION, HEGEMAN, KEITH MONK: "ELF", SPENDOR, A&D ARMS, ADC, RABCO, DECCA, PHASE LINEAR, OTARI TRANSCRIPTORS, SINCLAIR, JANZEN, SSI. We have the best demonstration "rooms" on the East Coast. TRANSCENDENTAL AUDIO, 1214 WALDEN AVE. BUFFALO, N.Y. 14211. 716-897-3984

AUDIO ENGINEERING Jan. '50—Dec. '69. Three issues missing. F.O.B. \$65, or best offer. J.P. Weber, 61 Meadow Farms Road; West Hartford, Connecticut 06107.

ELECTROENCEPHALOPHONE: brainwave monitor. Professional biofeedback instruments. J&J, 8102-A, Bainbridge, Wash. 98110.

CHICAGO'S AUDIO PERFECTIONISTS suggest you forget trips East or West or to small towns for state-of-the-art equipment. NO APPOINTMENT REQUIRED to hear and buy: **Audio Research** (Magneplanar, Dual 75, SP-3, Dyna Mod-kits), **B&O** (full line), **Crown** (Speakers, amps/pre-amps), **Decca** ("London" cartridges, International tone arm, Deccalifts, Microlifts, Kelly Ribbon tweeters), **E.S.S.** (Trans-Static I, etc.), **I.M.F.** (Speakers), **Infinity Systems** (Speakers), **Phase Linear**, **Quad** (demo of two, four, or "SuperQuad", 33/303, FM3, and AM3—stock), **Revox**, **Rogers** (phenomenal "BBC Monitor"), **Sheffield** (records, both), **Spendor** (new British speakers), **Stax** (both models electrostatic headphones—super unit is \$225, the UA-7 Tone arm, Headphone amplifier), **Transcrip** (both Hydraulic Reference and Saturn turntables, tone arms, accessory brushes, stylus-pressure gauge), as well as the **Syantific Audio** Record Cleaning Machine, at \$595. OPEN DAILY, 10-6 (Mon & Thur to 9 pm), and Tues., Wednes., Fri., or Sat. Evenings by appointment. Ten minute walk north on Chicago's Loop, near Gold Coast hotels. We welcome BankAmericard, MasterCharge, American Express. **THE AUDIOPHILE**, at 8 East Erie Street, Chicago 60611. Telephone (312) 787-0750.

STEREO SYSTEMS, LOW PRICES! Write or call: Purchase Radio Co., 747 Main St., Buffalo, N.Y. 14203 (716) 854-2124.

STEREO TAPE RENTALS CASSETTES AND CARTRIDGES Send \$0.75 for complete catalogue and rate schedule to

CAL TAPE
P.O. Box 5716
Redwood City, Calif. 94063

BUY IRISH TAPE at discount prices, get Free leaders trailers. Write for catalog and order form. Also ask for pre-recorded specials. Direct Mail Cassette Corp., Box 71, Plainview, N.Y. 11803.

MARANTZ rack panels for 71, 16-B and 20, All new, \$35.00 each. Bill Hagara, 1044 E. Main, Mesa, Ariz. 85203

TANDBERG 6000X, 4 track. Mint condition, Warranty, \$400.00. Charles Heinsohn, 47-51 40 ST., Sunnyside, N.Y. 11104. (212) BU8-4943. Days 7-4. Will Ship Postpaid.

EQUIPMENT WANTED

CASH FOR YOUR unwanted LP's and pre-recorded tapes. Record House, Hillburn, New York 10931.

WANTED: Sony Pre-amp 2000A. State condition and price. A. Blanchard, Rt. 2, Box 495, Chapel Hill, N.C. 27514

IONIC TWEETERS. J. Donovan, 3 Thompson, Marblehead, Mass.

URGENT WANT STAX CAPACITANCE CARTRIDGE IN GOOD WORKING CONDITION price no object. Call 916-452-5532

WANTED—Mint condition AMPEX 351-2 or 350 converted to 2 Track stereo w/or w/out modifications. Reply to Box #AA2-1.

WILL BUY Your unwanted Two Track Stereo pre-recorded tapes, good condition in original boxes. Mail list to James Lehman, 741 Belmeade, Corpus Christi, Texas 78412

OLD MICROPHONES 1920 to 1940. All makes and models. Also literature. Write Bob Paquette, 443 N. 31st Street, Milwaukee, Wis. 53208.

WANTED Teac RA-40 or RA-41 record amplifier for A4000SU. State price and Condition. N.Moss, WSJM Radio, St. Joseph, Mich. 49085

BUSINESS OPPORTUNITIES

START small, highly profitable electronic production in your basement investment, knowledge unnecessary. Postcard brings facts. Barta-A.M.E., Box 248, Walnut Creek, California 94579.

OFFICE AT HOME? HOME Business Operations Success Service gives valuable ideas. Free copy. Write HOME BOSS, Box 6374, San Antonio, Texas 78209

COMMISSION REPS., to sell A/V materials to schools and libraries. Protected territories with liberal commissions. Many choice territories still available. Learning Media Corporation, 231 N. 63 Street, Phila., Pa. 19139.

PIANO TUNING LEARNED QUICKLY AT HOME! Tremendous field! Musical knowledge unnecessary. GI Approved. Information Free. Empire School, Box 327, Miami, Florida 33145

HELP WANTED

ELECTRONICS/AVONICS Employment Opportunities. Report on jobs now open. FREE details. Aviation Employment Information Service, Dept. A. Box 240, Northport, N.Y. 11768.

Serious recordists to make and distribute records for major companies. We train and equip. Modest investment required. Send resume to Mr. Bloch, 418 N. Main St., Englewood, Ohio 45322.

Engineers required for design and development of consumer audio products. Must have design experience in at least one of the following: Loudspeakers, Magnetic Phonograph Cartridges or Microphones. Factory located in beautiful Western Connecticut 1½ hours from midtown New York. Write Box # AAUG2-3.

WANTED TO HIRE: General Manager for our large stereo—Hi-Fi Dept. Requirements: last five years in the stereo, Hi-Fi business, knowledge of most major brands; must be able to supervise store display, advertising, purchasing, salespersonnel, and bondable. Salary, benefits, etc. open according to qualifications. Kindly send written resume to Henry's Camera and Hi-Fi, 516 W. Eighth Street, Downtown Los Angeles, Calif. 90014.

RECORDS

OLDIES—45 RPM original labels and represses over 5,000 from personal collection for sale. Reasonable prices. Try me for the ones you've given up hope in finding. Call or write, Robert Fenster, 1503 Ave. J, Brooklyn, N.Y. (212) 258-5121.

OLDIES—45 RPM. Original hits. Catalog 50¢. C&S Record Sales, Box 197, Wampsville, N.Y. 13163.

CATALOGS. Broadcasts, soundtracks, Personalities of Thirties, Forties. Box 225, New York, N.Y. 10028.

RECORD COLLECTORS—Deleted, discontinued, "hard-to-find" LP's. Soundtracks, shows, classical our specialty. Send your want list to Dept. A, The Record House, Inc., 1101 Polk St., San Francisco, CA 94109.

DELETED L.P.'s? Get on my sales list. Vincent Scaparro, 904 Allerton Avenue, Bronx, N.Y. 10469.

Soundtracks, Hollywood, Broadway. Mint, sealed. Joseph Conan, Box 31161, El Paso, Texas 79931

SOUNDTRACKS—FREE CATALOGUE. R.T.S., 1111 S. Benito, Suite F, Alhambra, California 91803

THE GREATEST R&R ALBUM. Two years in compilation. Available only thru the mail and released in the original mono form. 19 songs including Bopalena, House of Blue Lights, Guitar Boogie, Strange Love, Mr. Engineer and more. All songs are stylistic landmarks in R&R. Send \$5.00 to Album, POB 1301 Studio City, Calif. 91604.

ORIGINAL HIT RECORDINGS. Popular entertainers 1920's, 1930's, 1940's New LP's. Low Prices. Fast Reply. DIBS-AD Box 388 San Pedro, Calif. 90733

TAPE RECORDINGS

RENT 4-TRACK open reel tapes—all major labels, 3,000 different. Free brochure. Stereo-Parti, 55 St. James Drive, Santa Rosa, Cal. 95401.

MEMOREX recording tape, audio & video lowest prices, write for free information BERGETZ SYSTEMS CO., Box 1181, Melrose Park, Ill. 60161.

STEREO TAPES, \$4.95 postpaid. CAG, 3606 Nanton Place, Phila., Pa. 19154.

BIG BANDS of the Thirties & Forties, Originals, Cassettes 90 Minutes \$6.00 Dale MC Clees Bx. 122C RR #4 Swanton, Ohio 43558.

AUDIOPHILES: Edit your tapes professionally write for free proven splicing tips discovered developing new improved splicing devices Nagy Research Products Box 289 McLean Va 22101

RENT any Cassette, Cartridge, or Open Reel Pre-recorded tape. All Labels. Catalog 75¢. Tape & Time, 1116 4th Ave. No., Sauk Rapids, Minn. 56379.

TAPE—Ampex, BASF, Sony, TDK, Memorex. From 52¢. Catalog 10¢. AudioCessories, 320 W. Edmonston, Rockville, Maryland 20852.

Radio/TV Bloopers. Famous personalities in embarrassing moments, previously unavailable commercially. Send 3.98/cassette or write: Bluepers Tapes, Box 4, Bayside, N.Y. 11361.

HELP—NEED SOMEONE TO COPY SOME OLD WIRE RECORDINGS TO TAPE. R.E. SCHLEIDT. BOX E, PISMO BEACH, CAL. 93449.

FOR SALE

JAPAN HONG KONG DIRECTORY. World products information. \$1.00 today. Sekai Shogyo Annai, Hillyard, Washington 99207.

LOWEST Prices Electronics Parts. Confidential Catalog Free. Knaco, 3174 8th Ave. S.W. Largo, Fla. 33540.

COUNTRY RECORDS and tape cartridges—fiddle tunes, blue grass, polkas. Free circular. Write Jim O'Neal, Box A50, Arcadia, Calif. 91006.

DIAMOND NEEDLES and Stereo Cartridges at Discount prices for Shure, Pickering, Stanton, Empire, Grado and ADC. Send for free catalog. All merchandise brand new and factory sealed. **LYLE CARTRIDGES**, Dept. A, P.O. Box 69, Kensington Station, Brooklyn, New York 11218.

FREE, discount price list. Nationally advertised components. Box 18123, Seattle, Wash. 98118.

DECCA MK. VII, Repeat MK V. This is not a misprint. At long last the ultimate cartridge hand picked and guaranteed from Music and Sound Ltd., 413 Johnson St., Jenkintown, Penna. 19046 215/885-4214

1800' NEW MYLAR TAPE IN HINGED BOXES; 12 reels for \$15.00 postpaid. Send for other price lists to **WIDE RESPONSE**, 2926 Bentley Ave., Los Angeles, Calif. 90064

Kenwood, Sansui, JVC, Nikko, Akai, Crown, Janszen, PL, IMF, Citation, ESS, SAE, LDE, JBL, Beyer-Revov, Tandberg, Hegeman, Phasel, Braun. Others. US PX Pricing No catalog, quotes only, immediate domestic delivery. Audiofax—District of Columbia, Box 7961 Atlanta, Ga 30309.

BOZAK CONCERT GRANDS Classic, Good condition. \$1,000. 215-582-2944. William Steward, 130 N. Mill Street, Birdsboro, Pa. 19508.

FOR SALE

SONY World Zone 23 band portable radio Model CRF 230. Has every conceivable feature. Powered by internal battery, 12 volt cigarette lighter socket or alternating current 100 to 240 volts. Perfect condition. \$395. **REVOX A77** Model 1124. Wood case with output amplifiers. New. \$395.00 **REVOX** Model 3400 microphones (4) New. \$35 each. **SANSUI SP2000** speaker. Flawless. \$70 **SANSUI SR202** Reverberation amplifier. Unused. \$55 **WANT Marantz 33** Preamp, 250 amplifier, wood cabinets and Sansui SP2500 speaker. Items must be as new. State history, serial numbers and date of purchase. **LTC James LiCalzi**, 1453B Fifth Ave., Fort Knox, KY 40121 (502 624 5086)

10½" reels Scotch special formula extra durable 3600ft. recording tape—new guaranteed perfect. While limited quantity lasts 10 for \$60, sample roll \$7 postpaid. **J. Makray**, P.O. Box 30312, Santa Barbara, Calif. 93105

SUPERB JBL SA-600C INTEGRATED AMPLIFIER. Unplayed since complete factory overhaul. First \$150 takes it, or get detailed test reports from: **David Pogue**, 2297 Stratton, Rockville, Md. 20854.

AUDIO RESEARCH speakers and amps, Crown, Decca, Infinity, Rabco, Revov, Tandberg, Thorens. The Stereo Shop, 935 S. Linn, Iowa City, Iowa 52240. (319) 338-9505.

10½" METAL AND PLASTIC REELS FROM \$1.50. **CARTER**, 423 SQUIRE CT., WIDFIELD, COLO. 80911

Mac 1700 Receiver—\$425; Metrotec Equalizer—\$55; Revov dustcover, service manual, reel with case. **E. Church**, Rt 1, Tolono, Ill. 61880

RARE STAMPS! 101 Old United States 1861-1935 \$1.50. Approvals. **J. Cuddihy**, 80 Lexington Ave., Jersey City, New Jersey 07304.

FOR SALE

POCKET MAGNETOMETERS enable serious recordists to determine when & if their equipment needs demagnetizing. The Han-D-Mag enables you to really do something about it. New Audiophile Han-D-Kits are now available. Includes Magnetometer, clip-on probe, Han-D-Mag with sensor strips, instructions and list of experiments. Price 20/B5 Kit \$29.75. Order direct or ask for data and bulletins.—**R. B. Annis Company** 1103 N. Delaware St. Indianapolis, Ind. 46202

DECCA CARTRIDGES; IMF Speakers; Mattes-Martin, C/M Labs, SAE, Teac electronics; Vanco switching device just \$30.00; **Ionophase Ionic High Frequency Units; pair Hartley Concert Juniors, special \$475.00.** We take trades. **Audiocraft**, South Rockwood, Michigan 48179. Telephone: (313) 379-9945.

Phase Linear, Crown, Radford, B&O, Braun, Klipsch, SAE, & Hegeman. Audio Labs., Inc. 2204 Ingersoll, Des Moines, Iowa 50312.

AMPEX MODIFICATIONS AND REBUILDS— 2 track to 8 track—Conversion Transistor Electronics—Studio Accessories—Mixdown Panels—**BKM Associates**, Box 22, Wilmington, Mass. 01887

Enjoy whopping savings on factory fresh stereo components. No fair trade here. Write for prompt quotations. Our 11th music year. **Potomac**, Box 34204, Washington, D.C. 20034

ACOUSTECH X full-range, bi-amped electrostatic speaker/amplifier system. Power amplifiers rebuilt to better-than-new specification. Panels constructed under personal supervision of **Arthur Janszen**, and recently cleaned by him—personally. In top shape, cosmetically perfect, absolutely reliable—\$1,000.00. Also have mint **MARANTZ 10B w/case—\$600.00** (617) 536-1990.

CLASSIFIED ORDER FORM

Want to buy, trade or sell components? Looking for a rare piece of equipment? Want to offer or buy a service? Want a job in the audio field? If your answer is "yes" to any of these questions, your ad belongs in Audio Classified. Rates are comfortably low—readership is astoundingly high. Use this handy order form to include message in the next issue.

PLEASE CHECK ONE:

- | | |
|---|---|
| <input type="checkbox"/> For Sale | <input type="checkbox"/> Insert in next issue |
| <input type="checkbox"/> Wanted to Buy or Trade | <input type="checkbox"/> Insert in next 2 issues |
| <input type="checkbox"/> Situation Wanted | <input type="checkbox"/> Insert in next 6 issues |
| <input type="checkbox"/> Help Wanted | <input type="checkbox"/> Insert in next 12 issues |
| <input type="checkbox"/> Services | <input type="checkbox"/> Assign box number |
| Other _____ | (additional cost \$1) |

Mail To: Audio Magazine, 134 No. 13th St., Philadelphia, Penna. 19107. For further information, check #135 on the Reader Service Card.

RATES: Commercial, 50¢ per word; situation wanted or non-commercial, 25¢ per word. We reserve the right to determine classification as commercial or non-commercial. **Payment must accompany all orders under \$10.00.**

Name _____

Address _____

City _____

State _____ Zip _____

Office
 Residence

COPY FOR YOUR AD

RADIO PROGRAMS

RADIO RERUNS, Complete broadcasts. 8¢ stamp for free catalog. Box 724-A, Redmond, Wash. 98052.

OLD RADIO PROGRAMS on Cassettes or Reels high quality, low prices thousands of your favorites live again, priced as low as \$8.00 for 6 hours. Catalog 50¢. Remember Radio Inc., Box 2513, Norman, Okla. 73069.

OLD RADIO PROGRAMS. Reels or cassettes. Free catalog. Fred Berney, 5931 S.W. 8 Street, Miami, Fla. 33144.

OLD RADIO PROGRAMS at very low prices yet a large selection. Catalog 50¢. The Best of Radio, P.O. Box 1692, F.D.R. Sta., New York, N.Y. 10022.

OLD RADIO PROGRAMS. CATALOG \$1.00 (refundable). The Radio Vault. Box 9032, Wyoming, Michigan. 49509.

FREE CATALOG. Radio Mysteries. Detective House, 218 Orangeview Lane, Lakeland, Fla. 33803.

MOST AMAZING SHOW ever produced for Radio; Ken Nordine, narrator, network cast. Introductory notes by show's creator-producer. Complete series, 19 Cassettes. Volume One, \$3.98; subsequent releases, 3 for \$10.00. Postpaid. Guaranteed. "Incredible, But, True!" Sawyer, Michigan 49125.

OLD RADIO SHOWS on tape. Complete broadcasts. High quality professional duplication. "Free" catalog. Command, Box 26348-L, San Francisco 94126.

GOLDEN AGE RADIO—Your best source for radio tapes. Box 8404-D, Olivette, Missouri 63132

OLD Radio Shows, Jazz/Big Band remotes, over 7000 selections, 650 reels, \$8.00 for 6 hrs. Plus bonus reels for accumulated orders, \$1.00 for catalog (refundable) McCoy's Recording, 1228 Lincoln Drive, Pasco, Washington 99301.

RADIO MEMORIES. All of your favorites on reel or cassette. Mystery, science fiction, comedy, adventure. Catalog, 50¢ in stamps or coin. (refundable) 1033 Gypsum, Salina, Kansas 67401.

COLOR SLIDES

SLIDES, ART-EDUCATIONAL-TRAVEL, 50,000 individually sold. Samples-Catalog \$1.00 refundable. Visuals D21 440 N.W. 130 Street, Miami, Florida 33168.

STAMP COLLECTING

CLOSEOUT: Stamps for collectors or to re-sell. Large assortment \$1. High value packet \$2. Schollmeyer, 436 N.Y. Ave., Brooklyn, N.Y. 11225.

MISCELLANEOUS

Don't Die without a will! Blank Will form protects your family. Only \$2—guaranteed! Order today!! Campbell, 2079 Woodbourne, Dept. 1AU, Baltimore 21239

SITUATION WANTED

Serious young lady wishes to get with respectable band/group that entertains in night clubs, or wishes to cut records. Write: Josephine Jones, Box 16, Birdsnest, Va. 23307.

SERVICES

DON'T PAY the high mail order prices. Thieves Warehouse is coming to your area. Franchises available. Thieves Warehouse, P.O. Box 8057, Pensacola, Florida 32505.

RENT STEREO TAPES \$1.50 week. Catalog 25¢ Tape Library, Box 8126, Washington, D.C. 20024.

CUSTOM RECORDING SERVICE. Tape and disc. Stereo and mono. Live and copies. Editing. Masters and pressings. High quality at reasonable rates Joseph Giovanelli, Audio-Tech Laboratories, 2819 Newkirk Ave., Brooklyn, N.Y. IN 9-7134.

LEARN Electronic Organ Servicing at home. All makes including transistors. Experimental kit—trouble-shooting. Accredited NHSC. Free Booklet. Niles Bryant School, 3631 Stockton, Dept. 1D, Sacramento, Calif. 95820.

TRADE STEREO TAPES, \$1.25 each postpaid. Minimum three. Tapetrade. Box 2181, La Jolla, Calif. 92073.

HIGH FIDELITY SPEAKERS REPAIRED
AMPRITE SPEAKER SERVICE
655 Sixth Avenue, New York 10, N.Y.

RECORDS MADE FROM YOUR TAPES. Also, editing and mastering. Send for free brochure. Nashville Record Productions, Inc., Dept. AM, 204 19th Ave., So., Nashville, Tennessee 37203.

CUSTOM STYLUS and cartridge re-tipping, repairing. (Weathers, Ortofon, Edison, Shure, etc.) Box 322A, Tuckahoe, N.Y. 10707. 914-SP 9-1297.

MUSICIANS, COMPANIES, get your sound around on 8-track, cassette, open reel. Quality duplicates at super low rates. Write for quick quote. N.R.J. Custom Services, 5523 W. Race Ave., Chicago, Ill. 60644

NEED A NEW HOME? SEND \$3.50 FOR PLAN BOOK TO:

RON WATSON DRAFTING SERVICE
5105 N.W. 16th
Okla. City, Oklahoma 73127 Money refunded with first order.

AMPEX MODIFICATIONS AND REBUILDS—2 track to 8 track—Conversion Transistor Electronics—Studio Accessories—Mixdown Panels—BKM Associates, Box 22, Wilmington, Mass. 01887.

Free sample back issue of *Stereophile*, the subscriber-supported magazine for audio perfectionists. Write Box 49A, Elwyn, Pa. 19063.

INVENTIONS WANTED

FREE "DIRECTORY OF 500 CORPORATIONS Seeking New Products." For information regarding development, sale, licensing of your patented/unpatented invention. Write: Raymond Lee Organization 230-AM Park Avenue, New York City 10017.

CARTOONING

Learn Cartooning at home. Free booklet. V.A. approved. Cartooning, Box 7069A0 Colorado Springs, Colorado 80907.

PLANS & KITS

INTEGRATED CIRCUIT KITS—Free catalog. FRAZER & ASSOCIATES, 3809 Surfwood Road, Malibu, California 90265.

BUILD your own **TELEPHONE ANSWERING SERVICE**. Put your **TAPE RECORDER TO WORK**. Detailed plans \$3.90. TONSCOPE-D 400 Third Ave., Satellite Beach, Fla. 32937

TUBES

TUBE TESTERS—Mercury Model 204, write: Bob Greber, 10144 Dunbarton Dr., El Paso, Texas 79925.

GOVERNMENT SURPLUS

JEEPS Typically From \$53.90 . . . Trucks From \$78.40 . . . Boats, Typewriters, Knives, Airplanes, Clothing, Multimeters, Oscilloscopes, Transceivers, Photographic, Electronics Equipment. Wide Variety, Condition 100,000 Bid Bargains Direct from Government Nationwide. Complete Sales Directory and Surplus Categories Catalog \$1.00 (Deductible On Orders From Separate Included Catalog). Surplus Service, Box 820-AUD, Holland, Michigan 49423.

INSTRUCTION & EDUCATION

FREE D.D.—M.D.—With Lifetime Ordination. Box 333 PM, Rillton, Pennsylvania 15678.

SIMPLIFIED Typing Course. 25¢. Tri-publications. 270—52nd St., Brooklyn, New York 11220.

EARN A BRITISH DEGREE in Color. Philosophy, Biochemistry, Radionics, Homeopathy, 35 courses. Curricular free. Dept. A. Brantridge Forest School. "Highfield." Dane Hill, Haywards Heath, Sussex, England.

STEREOS

COMPLETE LIST OF PRICES

FOR top manufacturers of stereo equipment. Write for quotations on all major brands of stereos.

STEREO COMPONENT CENTER
465 High St.,
Morgantown, West Virginia 26505

Check No. 70 on Reader Service Card

**We Don't Have Gimmicks
Just Low Prices**

Southern Sound Wholesalers

Every Major Brand

Mail Order Discount Prices
Same Day Service

•Memorex •Sherwood
•Garrard •Koss
•Dynaco •ADC
•KLH •A.R.
•Scotch •Harmon
Kardon

To Mention a Few!
"Ask For A Quote"

206 A. East Ayre Street
Newport, Delaware 19804
Phone 302/994-6667

Check No. 71 on Reader Service Card

(Continued from page 54)

as a matter of course, in order to match up our new tapes to those we have made via Dolby in former sessions and thus allow free inter-mixing of musical items to choice. Nice to know we can manage it.

The incongruities of this battery-powered recording session had me laughing more than once. Picture Arthur Grudko, a strapping lad with long legs, sitting flat on his fanny in the middle of the church's main aisle, the little Nagra in between! Some studio. Tail wags dog. And guess what was really the biggest encumbrance to our sessions, the bulkiest, heaviest, clumsiest item? No—not the playback gear. The mic stands.

Why, I tell you, the pair of "baby booms" with their big round-bottom discs weighed as much as the whole recording gear put together and more. Elephant like. It was those which I had to carry, while Arthur shouldered all the rest, at a couple of points in our travels; and I cursed them roundly. But, after all, you can't elevate pairs of four-hundred-buck mics into the air without something to hold them there. Short of ceiling cables, which were not in *our* books and aren't too often practicable, we hefted the booms, and the mics were returned intact.

We recorded a small group of ten singers, another of a few more, the full group of more than 20 and, at the end, a double chorus, spread out in the resonant space for a perfectly enormous sound. I chose cardioid treatment for the secular music (Monteverdi) and the more intimate English church anthems on our menu. For a Spanish cathedral sound, we strung up the omnis—and we were in Spain with trimmings. The double chorus was a problem, a big work by Brahms which demands musical separation of the two groups for its proper impact. Our earlier tries at double chorus had erred conservatively—not enough separation. This time, I overdid it, as I found out later. Not seriously; but I know now what I could have done for an even better effect. We put the two groups some 30 feet or so apart and aimed mics towards them diagonally from the center aisle. This gave us superb separation, but a sort of quadrature phasing in the accompanying reverb, at almost 90 degrees, mic to mic. It's effective, but I'm the artistic perfectionist . . . a straight-ahead

mic placement would have produced a smoother, more homogenized reverb background, I suspect. Next time, maybe.

On the mic note, I should add that for unaccompanied choral music of almost any sort one does *not* use accent mics. Those useful extras in standard classic and semi-classic recording are primarily for individual sounds, for single players or for groups of instruments such as brass, each playing a different line. A chorus, like a string section, blends multiple voices for each line of music and anything that tends to unblend those lines is bad for the musical sense. The only good reason for any accent mic, or anything at all beyond the basic pair of mics one to a channel, is the presence of a solo voice, or group of solos, within the larger chorus. Then, perhaps you can touch up. We didn't need to. And as a matter of fact, for most choral music a judicious placement of solo singers or groups in the space array will do a much better job than any extra mic involvement. 'Nuff said.

Four channel? It won't be much different.

I have written this piece in backwards format, working from the outside in. You may infer, so far, a great deal about the Nagra S stereo portable merely from my account of our proceedings. It is indeed an astonishing little machine, its tiny surfaces covered with the most amazing array of fine-grain controls, its inside crammed with micro-specifics beyond belief. The Nagra facilities are in fact so abundant and so complex that I'm going to beg off right now, except to say that Nagra's only practical compromises of any sort that I can think of, in return for batteries and tiny size, are the seven-inch reels and the battery rewind, which goes merely fast—not *very* fast.

The biggest features of all Nagras are three. First is the astonishing audio quality, second to virtually no other machine, of any size, which this mite-sized midget offers us at the pro speed of 15 ips and, correspondingly, at the slower speeds. Second is the utter assurance of its battery drive and the remarkably long life of its D cells in actual service. Clearly, a Swiss-watch mechanism is a primary element for maximum electrical/mechanical efficiency, but even more important is the fail-safe drive system. You can read the exact state of your batteries, for one thing, at any point in

the recording. And the speed maintains near-absolute accuracy straight down to a point very near the end of the battery life, in spite of gradually reduced voltage. You see, I can say this from first-hand experience.

Finally, there is the Nagra versatility, which has offered a special perfection in respect to sync operations. And here is an odd factor. Over the years, the mono Nagra has become the standard machine for professional sound film recording and is now neatly fitted to that function. Also to a variety of laboratory instrumentations which are aided by its extraordinary facilities. But, note well, this is all in mono. Films are still made in mono, unless they are something like Cinerama. Who needs stereo? Evidently a lot of film people are buying up the S model and using the "extra" track merely for sync signals. Anathema to a good art recording engineer!

On the other hand, most highly professionalized recording jobs are now done, in the art and entertainment field, via massive studio-located equipment, running from ordinary big four-track half-inchers all the way up to the 16-track monsters. These people, I would guess, are much too busy with their mammoth installations to take time out for a look at little Nagra, the recorder as big as a thimble.

Well, they're wrong, I am here to say. What one must experience to believe are the performance specs available from this machine using new modern tape. Keep the cassette in mind. If we can do what we now do with cassette tape, then how about quarter-inch tape at much higher speeds? For its useful portability and flexibility, the Nagra does *not* have to sacrifice audio. Not these days.

And so I suggest that a lot of recording people who have the wherewithal (which I don't) will want to shop Nagra and see/hear what two channels can do where there used to be one. The Nagra S.

Ah, yes, mustn't forget a last word on my tapes. No, at this writing they have *not* yet been snapped up by a recording company (I've barely finished making them). If one of you enterprising small outfits wants some challenge, I'm interested. Our music is admittedly not pops and won't run to a million pressings overnight. But it makes plenty nice listening, even so. That's the Canby Singers, conducted by the old audio crab himself, on Nagra recorded tape. **AE**

TEAC's new multi-track decks are the fourmost.

TEAC was the first to introduce four-channel decks, long before any others were around. Now we introduce the incomparable 3340: destined to be the fourmost.

A proven pro, this deck combines the best features of TEAC's forerunners. At first glance, you're struck by its studio sophistication. It's a professional 10½" deck with 15 and 7½-ips speeds, and it delivers "four-in-hand" versatility. TEAC's Simul-Sync™ system for recording individual instruments separately at any time, all in perfect sync. Added to its "one-man-band" recording ability, the 3340 records superb four-channel stereo, as well as regular two-channel stereo and ¼-track mono.

With the optional AX-20 mixdown panel, Simul-Sync recording can be dubbed down to two-channel stereo or mono demos.

1 2 3 4

AX-20

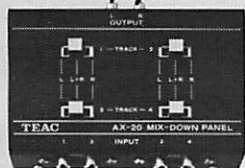

1 3
2 4

If you prefer slightly less four-channel sophistication, take a look at our new 2340. It's like the 3340, but with 7½ and 3¾-ips speeds, and takes 7-inch reels. If you want the fourmost, you owe yourself the best—a TEAC 2340 or 3340.

TEAC
TEAC Corporation of America, 7733 Telegraph Road, Montebello, California 90640
TEAC Corporation, 1-8-1 Nishi-shinjuku, Shinjuku-ku, Tokyo, Japan
TEAC EUROPE N.V., Kabelweg 45-47, Amsterdam-W.2, Holland
In Canada: White Electronic Development Corp., Ltd., Toronto
Check No. 29
on Reader Service Card





Middle-of-the-road stereo people are missing the fun of Marantz.

BLAH PEOPLE. Middle-of-the-road people who only listen to the midrange because their power amplifier **DISTORTS** the high and low frequencies. Because their 250 watt amplifier is really only 250 watts right in the middle. Because that's where it's measured **SMACK DAB IN THE MIDDLE!** So when the power drops off on either side they miss the **BOOM, KA BOOM** of a bass and the crisp **swisssh** of the wire brushes.

Now take the Marantz amplifier Model 250. Marantz says it delivers 250 watts RMS. That's 250 watts total RMS **CONTINUOUS** power. Over the whole powerpushin' listening range. Right through from 20 Hz to 20,000 Hz with total harmonic and intermodulation distortion at less than 0.1%! Fantastic!



Uncompromising music lover. Professional sound engineer. The Marantz 250 amplifier working in *any* system delivers continuous power at the critical **EXTREME** frequencies. **EXTREME** right. **EXTREME** left. **EXTREME** high. **EXTREME** low. Pure sounds. Total reality. Your kind of stereo.

Priced at \$495, the Marantz 250 professional power amplifier is only one of a brilliant line of components, receivers and speakers from the makers of the world's most expensive stereo equipment. Including a \$149.95 console amplifier.

Visit your Marantz dealer and listen to our line. Marantz stereo at any price is damn well worth it.

marantz.
We sound better.