

# **BLADE<sup>®</sup>**

# **180 CFX**



**Instruction Manual**  
**Bedienungsanleitung**  
**Manuel d'utilisation**  
**Manuale di Istruzioni**

**BNF<sup>™</sup>**  
**BASIC**

**AS3X<sup>®</sup>**

## NOTICE

All instructions, warranties and other collateral documents are subject to change at the sole discretion of Horizon Hobby, LLC. For up-to-date product literature, visit [horizonhobby.com](http://horizonhobby.com) and click on the support tab for this product.

## Meaning of Special Language

The following terms are used throughout the product literature to indicate various levels of potential harm when operating this product:

**NOTICE:** Procedures, which if not properly followed, create a possibility of physical property damage AND a little or no possibility of injury.

**CAUTION:** Procedures, which if not properly followed, create the probability of physical property damage AND a possibility of serious injury.

**WARNING:** Procedures, which if not properly followed, create the probability of property damage, collateral damage, and serious injury OR create a high probability of superficial injury.



**WARNING:** Read the ENTIRE instruction manual to become familiar with the features of the product before operating. Failure to operate the product correctly can result in damage to the product, personal property and cause serious injury.

This is a sophisticated hobby product. It must be operated with caution and common sense and requires some basic mechanical ability. Failure to operate this Product in a safe and responsible manner could result in injury or damage to the product or other property. This product is not intended for use by children without direct adult supervision. Do not use with incompatible components or alter this product in any way outside of the instructions provided by Horizon Hobby, LLC. This manual contains instructions for safety, operation and maintenance. It is essential to read and follow all the instructions and warnings in the manual, prior to assembly, setup or use, in order to operate correctly and avoid damage or serious injury.

**Age Recommendation: Not for children under 14 years. This is not a toy.**

## Safety Precautions and Warnings

- Always keep a safe distance in all directions around your model to avoid collisions or injury. This model is controlled by a radio signal subject to interference from many sources outside your control. Interference can cause momentary loss of control.
- Always operate your model in open spaces away from full-size vehicles, traffic and people.
- Always carefully follow the directions and warnings for this and any optional support equipment (chargers, rechargeable battery packs, etc.).
- Always keep all chemicals, small parts and anything electrical out of the reach of children.
- Always avoid water exposure to all equipment not specifically designed and protected for this purpose. Moisture causes damage to electronics.
- Never place any portion of the model in your mouth as it could cause serious injury or even death.
- Never operate your model with low transmitter batteries.
- Always keep aircraft in sight and under control.
- Always move the throttle fully down at rotor strike.
- Always use fully charged batteries.
- Always keep transmitter powered on while aircraft is powered.
- Always remove batteries before disassembly.
- Always keep moving parts clean.
- Always keep parts dry.
- Always let parts cool after use before touching.
- Always remove batteries after use.
- Never operate aircraft with damaged wiring.
- Never touch moving parts.



**WARNING AGAINST COUNTERFEIT PRODUCTS:** If you ever need to replace a Spektrum component found in a Horizon Hobby product, always purchase from Horizon Hobby, LLC or a Horizon Hobby authorized dealer to ensure authentic high-quality Spektrum product. Horizon Hobby, LLC disclaims all support and warranty with regards, but not limited to, compatibility and performance of counterfeit products or products claiming compatibility with DSM or Spektrum.

# BLADE® 180CFX

## Box Contents

- Blade® 180 CFX
- 450mAh 3S 11.1V 30C Li-Po Battery

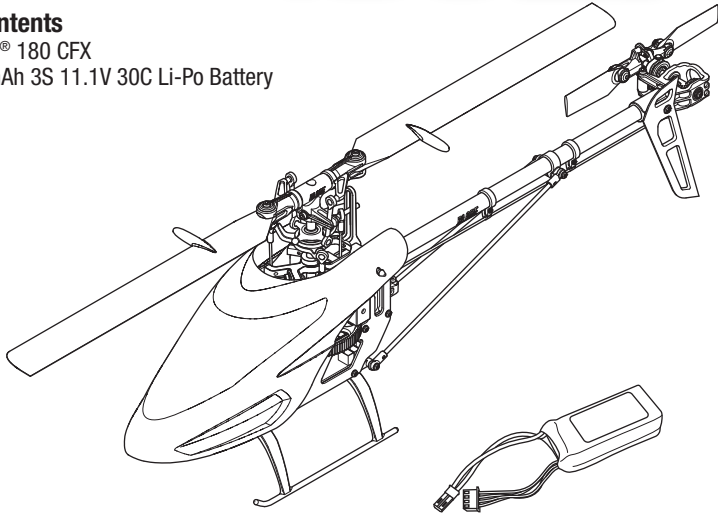

## Table of Contents

First Flight Preparation.....	4	Gyro Gain Adjustment .....	10
Flying Checklist .....	4	Post-Flight Inspections and Maintenance .....	10
Charging Warnings.....	4	Blade 180 CFX Troubleshooting Guide .....	11
Battery Charging.....	4	Exploded View .....	12
Transmitter Setup .....	4	Replacement Parts.....	13
Installing the Flight Battery .....	6	Optional Parts .....	13
Transmitter and Receiver Binding.....	7	Limited Warranty .....	13
Throttle Hold.....	7	Warranty and Service Contact Information .....	15
Control Tests.....	7	FCC Information.....	15
Blade 180 CFX Pre-Flight Checklist.....	9	IC Information .....	15
Flying the Blade 180 CFX.....	9	Compliance Information for the European Union.....	15
Low Voltage Cutoff (LVC) .....	10		

## Specifications

<b>Length</b>	13.4 in (340mm)	<b>Tail Rotor Diameter</b>	3.6 in (90.5mm)
<b>Height</b>	5.1 in (130mm)	<b>Flying Weight</b>	6.7 oz (190 g)
<b>Main Rotor Diameter</b>	14.2 in (360mm)		

## Included Items

Components		
Motor	Brushless Outrunner	installed
ESC	Castle Creations 15A	installed
Flybarless Unit	Spektrum™ AR6335 6-Channel AS3X® Nanolite Receiver	installed
Swash Servos	Nanolite High-Speed	installed
Tail Servo	DS76T Sub-Micro Digital Tail	installed
Battery	450mAh 3S 11.1V 30C Li-Po Battery	included

## Required Items

Components	
Charger	Dynamite® Prophet™ Sport Li-Po 35W AC Charger (DYNC2005)
Transmitter	Full Range DSM2®/DSMX® technology transmitter (DX6i and up)

To register your product online, visit [www.bladehelis.com](http://www.bladehelis.com)

## First Flight Preparation

- Remove and inspect contents
- Begin charging the flight battery
- Install the flight battery in the helicopter (once it has been fully charged)
- Program your computer transmitter
- Bind your transmitter
- Familiarize yourself with the controls
- Find a suitable area for flying

## Charging Warnings



**CAUTION:** All instructions and warnings must be followed exactly. Mishandling of Li-Po batteries can result in a fire, personal injury and/or property damage.

- **NEVER LEAVE THE POWER SUPPLY, CHARGER AND BATTERY UNATTENDED DURING USE.**
- **NEVER CHARGE BATTERIES OVERNIGHT.**
- By handling, charging or using the included Li-Po battery, you assume all risks associated with lithium batteries.
- If at any time the battery begins to balloon or swell, discontinue use immediately. If charging or discharging, discontinue and disconnect. Continuing to use, charge or discharge a battery that is ballooning or swelling can result in fire.
- Always store the battery at room temperature in a dry area for best results.
- Always transport or temporarily store the battery in a temperature range of 40–120° F (5–49° C). Do not store the battery or model in a car or direct sunlight. If stored in a hot car, the battery can be damaged or even catch fire.

## Flying Checklist

- Always turn the transmitter on first**
- Plug the flight battery into the lead from the ESC
- Allow the receiver and ESC to initialize and arm properly
- Fly the model
- Land the model
- Unplug the flight battery from the ESC
- Always turn the transmitter off last**

- Always charge batteries away from flammable materials.
- Always inspect the battery before charging.
- Always disconnect the battery after charging, and let the charger cool between charges.
- Always constantly monitor the temperature of the battery pack while charging.
- **ONLY USE A CHARGER SPECIFICALLY DESIGNED TO CHARGE LI-PO BATTERIES.** Failure to charge the battery with a compatible charger may cause a fire resulting in personal injury and/or property damage.
- Never discharge Li-Po cells to below 3V under load.
- Never cover warning labels with hook and loop strips.
- Never charge batteries outside recommended levels.
- Never charge damaged batteries.
- Never attempt to dismantle or alter the charger.
- Never allow minors to charge battery packs.
- Never charge batteries in extremely hot or cold places (recommended between 40–120° F (5–49° C)) or place in direct sunlight.

## Battery Charging

Choose a charger designed to balance charge 3S Li-Po batteries. We recommend the Dynamite Prophet Sport Li-Po 35W AC Charger (DYNC2005). Refer to your charger manual for charging instructions.

## Transmitter Setup

**Program your transmitter before attempting to bind or fly the helicopter.** Transmitter programming values are shown below for the *Spektrum* DX6i, DX7/DX7se, DX6, DX7s,

DX8, DX9 and DX18. The files for models using *Spektrum*™ transmitters with *AirWare*™ software are also available for download online in the Spektrum Community.

### DX6i

SETUP LIST		ADJUST LIST				
<b>Model Type</b>	HELI	<b>Thro Curve</b>				
<b>Reverse</b>		NORM	0%	25%	25%	25%
THRO	N	STUNT	100%	100%	100%	100%
AILE	N	HOLD	0%	0%	0%	0%
ELEV	N	<b>Pitc Curve</b>				
RUDD	N	NORM	30%	40%	50%	75%
GYRO	N	STUNT	0%	25%	50%	75%
PITC	R	HOLD	0%	25%	50%	75%
<b>Swash Type</b>		<b>Travel Adj</b>				
1 Servo 90		THRO	Low: 100%	Hi: 100%		
<b>Timer</b>		AILE	100%		<b>Gyro</b>	
3:00		ELEV	100%		Rate	SW-F. Mode
		RUDD	100%		NORM	50%
		GYRO	100%		STUNT	50%
		PITC	100%			

## DX7/DX7se

<b>SYSTEM LIST</b> <b>Model Type</b> HELI  <b>Swatch Type</b> 1 Servo 90	<b>FUNCTION MODE</b>				
	<b>D/R &amp; EXP</b>				
	0-AILE	100%	0%		
	0-ELEV	100%	0%		
	0-RUDD	100%	INH		
	1-AILE	85%	0%		
	1-ELEV	85%	0%		
	1-RUDD	85%	INH		
	<b>Thro Curve</b>				
	NORM	0%	25%	25%	25%
	ST-1	75%	75%	75%	75%
	ST-2	100%	100%	100%	100%
	HOLD	0%	0%	0%	0%
	<b>Pitc Curve</b>				
	NORM	30%	INH	50%	INH
ST-1	0%	INH	50%	INH	
ST-2	0%	INH	50%	INH	
HOLD	0%	INH	50%	INH	
<b>Travel Adj</b>		<b>Reversing SW</b>			
THRO	Low: 100%	Hi: 110%	THRO	N RUDD N	
AILE	100%		AILE	N GEAR N	
ELEV	100%		ELEV	N PIT. N	
RUDD	100%				
GEAR	100%		<b>Gyro SENS</b>		
PIT.	100%		AUTO	F.MODE	
			STNT	50%	
			HOLD	50%	
				<b>Timer</b>	
				3:00	

## DX6/DX7s/DX8/DX9/DX18

<b>SYSTEM SETUP</b> <b>Model Type</b> HELI <b>Swash Type</b> 1 Servo Normal <b>F-Mode Setup</b> Flight Mode: F Mode Hold: Hold <b>Frame Rate</b> 22ms DSMX	<b>FUNCTION LIST</b>									
	<b>D/R &amp; Expo</b>									
	0-AILE	100%	0%							
	0-ELEV	100%	0%							
	0-RUDD	100%	0%							
	1-AILE	85%	0%							
	1-ELEV	85%	0%							
	1-RUDD	85%	0%							
	2-AILE	85%	0%							
	2-ELEV	85%	0%							
	2-RUDD	85%	0%							
	<b>Throttle Curve</b>									
	NORM	0%	25%	25%	25%	25%				
	ST-1	75%	75%	75%	75%	75%				
	ST-2 (DX8, 9, 18)	100%	100%	100%	100%	100%				
HOLD	0%	0%	0%	0%	0%					
<b>Pitch Curve</b>										
NOR	30%	40%	50%	75%	100%					
ST-1	0%	25%	50%	75%	100%					
ST-2 (DX8/18 only)	0%	25%	50%	75%	100%					
HOLD	0%	25%	50%	75%	100%					
<b>SERVO SETUP</b>										
<b>Travel</b>										
THRO	Low: 100%	Hi: 110%								
AILE	100%									
ELEV	100%									
RUDD	100%									
GEAR	100%									
PIT.	100%									
<b>Reverse</b>										
THRO	N									
AILE	N									
ELEV	N									
RUDD	N									
GEAR	N									
PIT.	N									
<b>Timer</b>										
MODE	Countdown									
TIME	3:00	Tone/Vibe								
START	Throttle Cut									
POS	25									
<b>Gyro</b>										
SW										
CH										
NORMAL/POS 0	75%									
STUNT 1/POS 1	75%									
STUNT 2/POS 2	75%									
HOLD	75%									

## Installing the Flight Battery

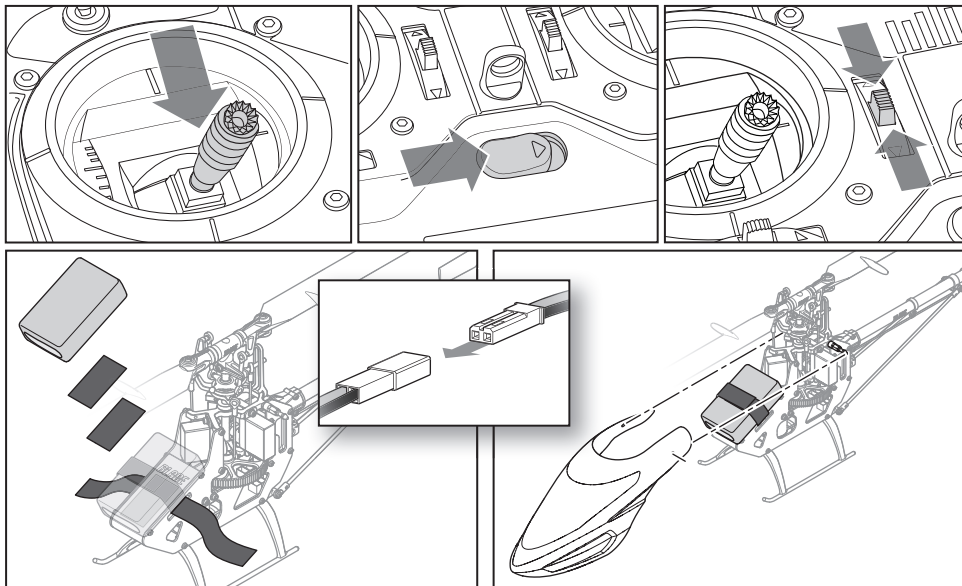

1. Lower the throttle.
2. Power on the transmitter.
3. Center the throttle trim.
4. To allow the ESC to arm and to keep rotors from initiating at startup, turn on throttle hold and normal flight mode before connecting the flight battery. Please refer to your transmitter manual for more information on programming throttle hold and normal flight mode.
5. Attach hook material to the helicopter frame and loop material to the battery.
6. Install the flight battery on the helicopter frame. Secure the flight battery with a hook and loop strap. Connect the battery cable to the ESC.



**CAUTION:** Always keep the power lead positioned **AWAY** from the elevator servo. Failure to do so could cause the lead to get caught and will result in crash causing property damage and injury.



**CAUTION:** Make sure the flight battery does not come in contact with the motor. Failure to do so will cause the motor, ESC and battery to overheat, resulting in crash, causing property damage and injury.

7. Do not move the helicopter until the receiver initializes. The LED on the receiver glows solid when the helicopter is initialized.
8. The helicopter motor will emit 2 tones, indicating the ESC is armed.



**CAUTION:** Always disconnect the Li-Po battery from the aircraft receiver when not flying to avoid over-discharging the battery. Batteries discharged to a voltage lower than the lowest approved voltage may become damaged, resulting in loss of performance and potential fire when batteries are charged.

## Transmitter and Receiver Binding

Binding is the process of programming the receiver to recognize the GUID (Globally Unique Identifier) code of a single specific transmitter. You need to 'bind' your chosen

Spektrum™ DSM2/DSMX technology equipped aircraft transmitter to the receiver for proper operation.

### Binding Procedure

1. Disconnect the flight battery from the helicopter.
2. Refer to the Transmitter Setup Table to correctly set up your transmitter.
3. Lower the throttle and throttle trim to the lowest position.
4. Power off the transmitter and move all switches to the 0 position.
5. Install the bind plug in the bind port extension.
6. Connect the flight battery to the ESC. The receiver LED flashes, indicating it is in bind mode.
7. Put the transmitter into bind mode while powering on the transmitter.
8. Release the bind button/switch after 2–3 seconds. The helicopter is bound when the LED on the receiver turns solid.
9. Disconnect the flight battery and remove the bind plug. Store the bind plug in a convenient place.

**NOTICE:** Remove the bind plug to prevent the system from entering bind mode the next time the power is turned on. If you encounter problems, obey binding instructions and refer to transmitter troubleshooting guide for other

instructions. If needed, contact the appropriate Horizon Product Support office. For a list of compatible DSM transmitters, please visit [www.bindnfly.com](http://www.bindnfly.com).

## Throttle Hold

Throttle hold only turns off the motor on an electric helicopter. You must maintain pitch and direction control.

The blades will spin if throttle hold is OFF. For safety, turn throttle hold ON any time you need to touch the helicopter or check the direction controls.

Throttle hold is also used to turn off the motor if the helicopter is out of control, in danger of crashing, or both.

Please refer to your transmitter manual for more information on programming throttle hold.

## Control Tests

Test the controls prior to the first flight to ensure the servos, linkages and parts operate correctly. Turn on Throttle Hold when doing the control tests.

### Elevator

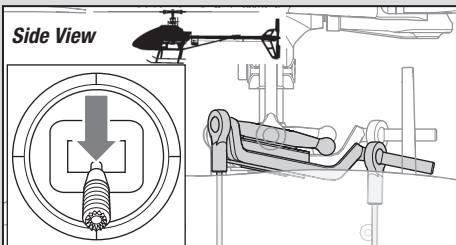
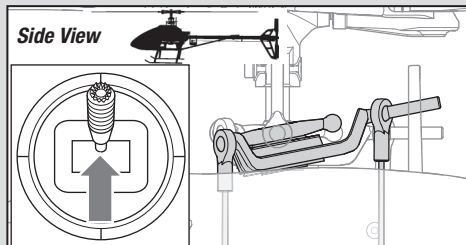

### Aileron

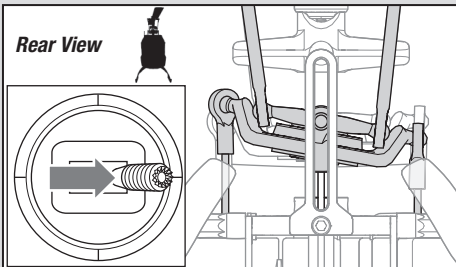
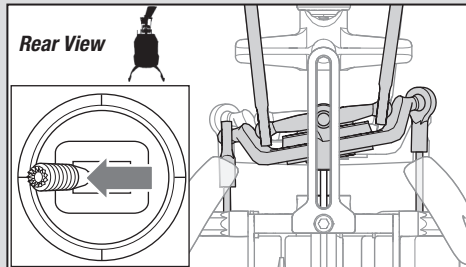

## Rudder

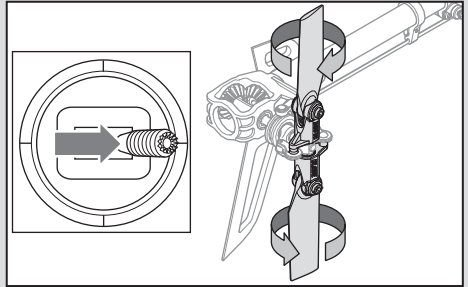
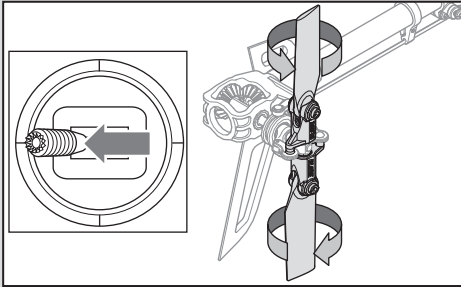

## Collective Pitch

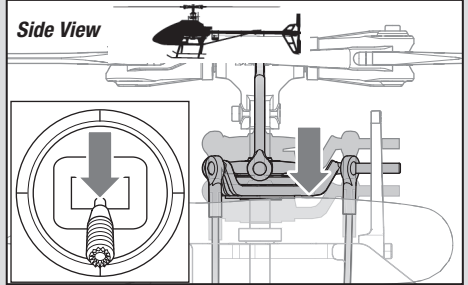
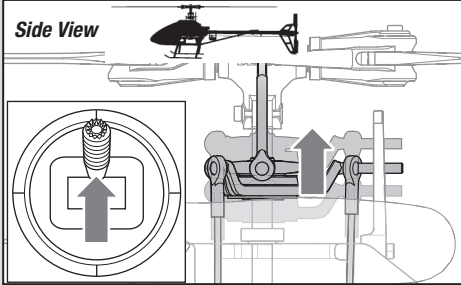

## Motor Control Test

Place the helicopter outdoors on a clean, flat and level surface (concrete or asphalt) free of obstructions. Always stay clear of moving rotor blades.

1. The motor beeps twice when the helicopter's ESC arms properly. Before you continue, confirm that TH HOLD is ON.

**WARNING:** The motor will spin when throttle is increased while TH HOLD is OFF.

2. Check the swashplate directions to ensure they are moving in the correct direction. Please refer to the diagrams above for reference.

**WARNING:** Stay at least 30 feet (10 meters) away from the helicopter when the motor is running. Do not attempt to fly the helicopter at this time.

3. Ensure the throttle is lowered completely. Turn throttle hold off at this time and confirm the transmitter is still set to normal flight mode. Slowly increase the throttle until the blades begin to spin. The main blades spin clockwise when viewing the helicopter from the top. The tail rotor blades spin counterclockwise when viewing the helicopter from the right-hand side.

**NOTICE:** If the main rotor blades are spinning counterclockwise, reduce the throttle to low immediately. Turn throttle hold on. Disconnect the battery from the helicopter and reverse any two motor wire connections to the ESC and repeat the motor control test.



## Blade 180 CFX Pre-Flight Checklist

- Check all screws to ensure that they are tight
- Check main and tail blades to ensure they are not damaged
- Check all links to make sure they move freely, but do not pop off easily
- Check that flight battery and transmitter battery are fully charged
- Check all wires to ensure that they are not cut, pinched, or chaffed and are properly secured
- Check all wire connections
- Check gears to make sure no teeth are missing
- Do a complete control test
- Check that the servos are functioning properly
- Check to make sure the flight battery is properly secured
- Check to make sure the receiver is properly secured

## Flying the Blade 180 CFX

### Consult local laws and ordinances before choosing a location to fly your aircraft.

Select a large, open area away from people and objects. Your first flights should be outdoors in low-wind conditions. Always stay at least 30 feet (10 meters) away from the helicopter when it is flying.

The Blade 180 CFX is intended to be flown outdoors or inside a large gymnasium.

### Takeoff

Deliberately increase throttle and establish a hover at least 24" (0.6 meter) high, outside of ground effect.

 **CAUTION:** Do not give any aileron, elevator or rudder commands before takeoff or the helicopter may crash during takeoff.

### Flying

The helicopter lifts off the ground when the rotor head reaches a suitable speed. Establish a low-level hover outside of ground effect to verify proper operation of your helicopter. You must not set any trim; the flybarless design of the Blade 180 CFX renders trim unnecessary. Setting trim or sub-trim can cause an unwanted drift or rotation of the helicopter.

First flights should be performed in normal mode and low cyclic and rudder dual rates until you are familiar with the flying manner of the Blade 180 CFX. Discover the rates that fit your flying style.



**CAUTION:** Always fly the helicopter with your back to the sun and the wind to prevent loss of flight control.

### Landing

Establish a low level hover. Deliberately lower the throttle until the helicopter lands. Do not give any aileron, elevator or rudder commands when the helicopter is landing.

### When the helicopter is in stunt mode:

- The rotor head speed is constant.
- The main rotor will increase negative pitch as the throttle/collective stick is moved from the middle stick position to the low stick position. Negative pitch allows the helicopter to fly upside down and perform aerobatics.

Change between stunt and idle up modes in a hover with the throttle near the hovering stick position.

The helicopter may go up or down when you change between modes due to the difference in the throttle and pitch curves.

If the cyclic control is too slow or too fast, adjust the transmitter dual rates, expo or throttle curve to fit your liking.

**For advanced AS3X settings please go to [Bladeheli.com](http://Bladeheli.com) and refer to the 180 CFX page.**

## Low Voltage Cutoff (LVC)

---

Once the battery reaches 9V under load, the ESC will continuously lower power supplied to the motor until complete shutdown occurs. This helps prevent over-discharge of the Li-Po battery. Land immediately once the ESC activates LVC. Continuing to fly after LVC can damage the battery, cause a crash or both. Crash damage and batteries damaged due to over-discharge are not covered under warranty.

Repeatedly flying the helicopter until LVC activates will damage the helicopter battery.

Disconnect and remove the Li-Po battery from the aircraft after use to prevent trickle discharge. During storage, make sure the battery charge does not fall below 3V per cell.

## Gyro Gain Adjustment

---

If the tail wags or oscillates, lower the gain on the gyro. On your transmitter's gyro menu, decrease the gyro gain values a small amount until the helicopter is stable within a particular flight mode.

If the tail is drifting while hovering, increase the gain on the gyro. On your transmitter, increase the gyro gain values a small amount at a time until the tail starts to wag/oscillate. Afterwards, reduce the gain until the tail stops wagging/oscillating within a particular flight mode.

## Post-Flight Inspections and Maintenance

---

<b>Ball Links</b>	Make sure the plastic ball link holds the control ball, but is not tight (binding) on the ball. When a link is too loose on the ball, it can separate from the ball during flight and cause a crash. Replace worn ball links before they fail.
<b>Cleaning</b>	Make sure the battery is not connected before cleaning. Remove dust and debris with a soft brush or a dry lint-free cloth.
<b>Bearings</b>	Replace bearings when they become notchy (sticky in places when turning) or draggy.
<b>Wiring</b>	Make sure the wiring does not contact moving parts. Replace damaged wiring and loose connectors.
<b>Fasteners</b>	Make sure there are no loose screws, other fasteners or connectors. Do not over tighten metal screws in plastic parts. Tighten screw so parts are mated together, then turn screw only 1/8th of a turn more.
<b>Rotors</b>	Make sure there is no damage to rotor blades and other parts which move at high speed. Damage to these parts includes cracks, burrs, chips or scratches. Replace damaged parts before flying.
<b>Gyro</b>	Make sure the receiver is securely attached to the frame. Replace the double-sided tape when necessary. The helicopter will crash if the receiver separates from the helicopter frame.

## Blade 180 CFX Troubleshooting Guide

Problem	Possible Cause	Solution
Helicopter will not bind to the transmitter (during binding)	Low flight battery or transmitter battery voltage	Fully charge or replace the flight battery and/or transmitter batteries
	The receiver is not in bind mode	Make sure the bind plug is connected to the receiver bind port extension
	Transmitter is not in bind mode	Refer to your transmitter's instruction manual for binding instructions
	Transmitter too close to the helicopter during the binding process	Power off the transmitter. Move the transmitter to a larger distance from the helicopter. Disconnect and reconnect the flight battery to the helicopter and follow binding instructions
Helicopter will not link to the transmitter (after binding)	Helicopter is bound to a different model memory (ModelMatch™ radios only)	Disconnect the flight battery. Select the correct model memory on the transmitter. Reconnect the flight battery
	Flight battery/Transmitter battery charge is too low	Replace or recharge batteries
The receiver will not initialize	The helicopter was moved during initialization	Lay the helicopter on its side during initialization if windy
	The transmitter is powered off	Power on the transmitter
	Controls are not centered	Center elevator, aileron and rudder controls. Make sure the throttle is at idle
Helicopter will not respond to the throttle but responds to other controls	Throttle not at idle and/or throttle trim is too high	Lower the throttle stick and throttle trim to the lowest settings
	The transmitter is not in normal mode or throttle hold is on	Make sure the transmitter is in normal mode and throttle hold is off
	The motor is not connected to the ESC or the motor wires are damaged	Connect the motor wires to the ESC and check motor wires for damage
	Flight battery charge is too low	Replace or recharge flight battery
	Throttle channel is reversed	Power down helicopter. Reverse the throttle channel on the transmitter
Helicopter power is lacking	Flight battery has low voltage	Fully charge the flight battery
	Flight battery is old or damaged	Replace the flight battery
	Flight battery cells are unbalanced	Fully charge the flight battery, allowing the charger time to balance the cells
	Excessive current is being drawn through the BEC	Check all servos and the helicopter motor for damage
Helicopter will not lift off	Main rotor head is not spinning in the correct direction	Make sure the main rotor head is spinning clockwise. Refer to motor control test
	Transmitter settings are not correct	Check throttle and pitch curve settings
	Flight battery has low voltage	Fully charge the flight battery
	Main rotor blades are installed backwards	Install the main rotor blades with the thicker side as the leading edge
The helicopter tail spins out of control	Rudder control and/or sensor direction reversed	Make sure the rudder control and the rudder sensor are operating in the correct direction
	Tail servo is damaged	Check the rudder servo for damage and replace if necessary
	Inadequate control arm throw	Check the rudder control arm for adequate travel and adjust if necessary
The helicopter wobbles in flight	Head speed is too low	Increase the helicopter's head speed via your transmitter settings and/or using a freshly charged flight pack
	Dampers are worn	Replace the main rotor head dampers

# Exploded View

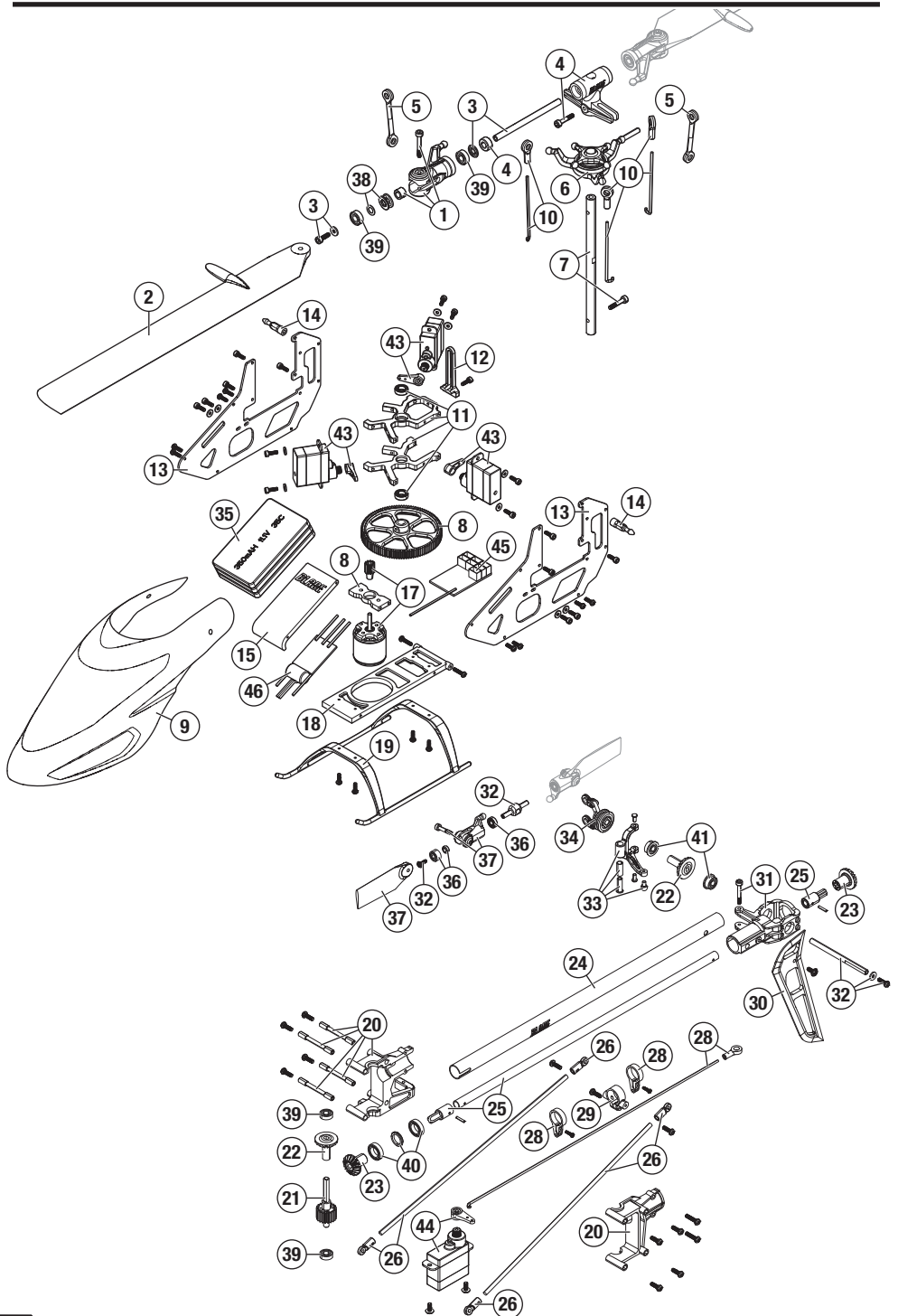

## Replacement Parts

#	Part #	Description
1	BLH3401	Main Blade Grips: 180 CFX
2	BLH3402	Main Blades: 180 CFX
3	BLH3403	Feathering Spindle Set: 180 CFX
4	BLH3404	Main Rotor Head Block: 180 CFX
5	BLH3405	Rotor Head Linkage Set: 180 CFX
6	BLH3406	Swashplate: 180 CFX
7	BLH3407	Main Shaft Set: 180 CFX
8	BLH3408	Main Gear: 180 CFX
9	BLH3409	Stock Canopy: 180 CFX
10	BLH3410	Servo Control Linkage Set: 180 CFX
11	BLH3411	Main Bearing Block Set: 180 CFX
12	BLH3412	Anti-Rotation Bracket: 180 CFX
13	BLH3413	Carbon Fiber Main Frame: 180 CFX
14	BLH3414	Body Post Set: 180 CFX
15	BLH3415	Battery Tray: 180 CFX
16	BLH3416	Motor Mount: 180 CFX
17	BLH3417	Brushless Main Motor: 180 CFX
18	BLH3418	Bottom Plate: 180 CFX
19	BLH3419	Landing Gear: 180 CFX
20	BLH3420	Front Tail Boom Case: 180 CFX
21	BLH3421	Tail Pinion Gear/Shaft: 180 CFX
22	BLH3422	Bevel Gear: 180 CFX
23	BLH3423	Torque Tube Gear: 180 CFX
24	BLH3424	Tail Boom (2): 180 CFX

#	Part #	Description
25	BLH3425	Torque Tube (2): 180 CFX
26	BLH3426	Boom Support Set: 180 CFX
27	BLH3427	Tail Pushrod (2): 180 CFX
28	BLH3428	Tail Pushrod Guide Set: 180 CFX
29	BLH3429	Tail Boom Clamp: 180 CFX
30	BLH3430	Vertical Fin: 180 CFX
31	BLH3431	Tail Case Set: 180 CFX
32	BLH3432	Tail Shaft and Hub: 180 CFX
33	BLH3433	Tail Pitch Bellcrank: 180 CFX
34	BLH3434	Tail Pitch Slider: 180 CFX
35	BLH3435	Tail Grip Set: 180 CFX
36	BLH3436	Tail Grip Bearing Set: 180 CFX
37	BLH3437	Tail Blade Set: 180 CFX
38	BLH3438	2.5x6x2.8mm Thrust Bearing: 180 CFX
39	BLH3439	2.5x6x1.8mm Radial Bearing: 180 CFX
40	BLH3440	5x8x2mm Radial Bearing: 180 CFX
41	BLH3441	2.5x6x2.6mm Flanged Bearing: 180 CFX
42	EFLB4503SJ30	450mAh 3S 11.1V 30C Li-Po Battery
43	SPMSH2060	Nanolite High-Speed Heli Servo
44	EFLRDS76TJ	7.6g Sub-Micro Digital Tail Servo JST
45	SPMAR6335	AR6335 6-Channel AS3X Nanolite Receiver
46	BLH3442	Castle Creations 15A Blade ESC

## Optional Parts

Part #	Description
BLH3401A	Aluminum Main Blade Grips: 180 CFX
BLH3402C	Carbon Fiber Main Blades: 180 CFX
BLH3404A	Aluminum Main Rotor Head Block: 180 CFX
BLH3406A	Aluminum Swashplate: 180 CFX
BLH3409B	Fiberglass Canopy: 180 CFX
BLH3431A	Aluminum Tail Case Set: 180 CFX
BLH3433A	Aluminum Tail Pitch Bellcrank: 180 CFX

Part #	Description
DYNC2005	Prophet Sport Li-Po 35W AC Charger
	DX6i DSMX 6-Channel Transmitter Only
	DX6 DSMX 6-Channel Transmitter Only
	DX7s DSMX 7-Channel Transmitter Only
	DX8 DSMX 8-Channel Transmitter Only
	DX9 DSMX 9-Channel Transmitter Only
	DX18 DSMX 18-Channel Transmitter Only

## Limited Warranty

### What this Warranty Covers

Horizon Hobby, LLC, (Horizon) warrants to the original purchaser that the product purchased (the "Product") will be free from defects in materials and workmanship at the date of purchase.

### What is Not Covered

This warranty is not transferable and does not cover (i) cosmetic damage, (ii) damage due to acts of God, accident, misuse, abuse, negligence, commercial use, or due to improper use, installation, operation or maintenance, (iii) modification of or to any part of the Product, (iv) attempted service by anyone other than a Horizon Hobby authorized

service center, (v) Product not purchased from an authorized Horizon dealer, or (vi) Product not compliant with applicable technical regulations.

OTHER THAN THE EXPRESS WARRANTY ABOVE, HORIZON MAKES NO OTHER WARRANTY OR REPRESENTATION, AND HEREBY DISCLAIMS ANY AND ALL IMPLIED WARRANTIES, INCLUDING, WITHOUT LIMITATION, THE IMPLIED WARRANTIES OF NON-INFRINGEMENT, MERCHANTABILITY AND FITNESS FOR A PARTICULAR PURPOSE. THE PURCHASER ACKNOWLEDGES THAT THEY ALONE HAVE DETERMINED THAT THE PRODUCT WILL SUITABLY MEET THE REQUIREMENTS OF THE PURCHASER'S INTENDED USE.

## Purchaser's Remedy

Horizon's sole obligation and purchaser's sole and exclusive remedy shall be that Horizon will, at its option, either (i) service, or (ii) replace, any Product determined by Horizon to be defective. Horizon reserves the right to inspect any and all Product(s) involved in a warranty claim. Service or replacement decisions are at the sole discretion of Horizon. Proof of purchase is required for all warranty claims. SERVICE OR REPLACEMENT AS PROVIDED UNDER THIS WARRANTY IS THE PURCHASER'S SOLE AND EXCLUSIVE REMEDY.

## Limitation of Liability

HORIZON SHALL NOT BE LIABLE FOR SPECIAL, INDIRECT, INCIDENTAL OR CONSEQUENTIAL DAMAGES, LOSS OF PROFITS OR PRODUCTION OR COMMERCIAL LOSS IN ANY WAY, REGARDLESS OF WHETHER SUCH CLAIM IS BASED IN CONTRACT, WARRANTY, TORT, NEGLIGENCE, STRICT LIABILITY OR ANY OTHER THEORY OF LIABILITY, EVEN IF HORIZON HAS BEEN ADVISED OF THE POSSIBILITY OF SUCH DAMAGES. Further, in no event shall the liability of Horizon exceed the individual price of the Product on which liability is asserted. As Horizon has no control over use, setup, final assembly, modification or misuse, no liability shall be assumed nor accepted for any resulting damage or injury. By the act of use, setup or assembly, the user accepts all resulting liability. If you as the purchaser or user are not prepared to accept the liability associated with the use of the Product, purchaser is advised to return the Product immediately in new and unused condition to the place of purchase.

## Law

These terms are governed by Illinois law (without regard to conflict of law principals). This warranty gives you specific legal rights, and you may also have other rights which vary from state to state. Horizon reserves the right to change or modify this warranty at any time without notice.

## WARRANTY SERVICES

### Questions, Assistance, and Services

Your local hobby store and/or place of purchase cannot provide warranty support or service. Once assembly, setup or use of the Product has been started, you must contact your local distributor or Horizon directly. This will enable Horizon to better answer your questions and service you in the event that you may need any assistance. For questions or assistance, please visit our website at [www.horizonhobby.com](http://www.horizonhobby.com), submit a Product Support Inquiry, or call the toll free telephone number referenced in the Warranty and Service Contact Information section to speak with a Product Support representative.

### Inspection or Services

If this Product needs to be inspected or serviced and is compliant in the country you live and use the Product in, please use the Horizon Online Service Request submission process found on our website or call Horizon to obtain a Return Merchandise Authorization (RMA) number. Pack the

Product securely using a shipping carton. Please note that original boxes may be included, but are not designed to withstand the rigors of shipping without additional protection. Ship via a carrier that provides tracking and insurance for lost or damaged parcels, as Horizon is not responsible for merchandise until it arrives and is accepted at our facility. An Online Service Request is available at [http://www.horizonhobby.com/content/\\_service-center\\_render-service-center](http://www.horizonhobby.com/content/_service-center_render-service-center). If you do not have internet access, please contact Horizon Product Support to obtain a RMA number along with instructions for submitting your product for service. When calling Horizon, you will be asked to provide your complete name, street address, email address and phone number where you can be reached during business hours. When sending product into Horizon, please include your RMA number, a list of the included items, and a brief summary of the problem. A copy of your original sales receipt must be included for warranty consideration. Be sure your name, address, and RMA number are clearly written on the outside of the shipping carton.

**NOTICE:** Do not ship Li-Po batteries to Horizon. If you have any issue with a Li-Po battery, please contact the appropriate Horizon Product Support office.

## Warranty Requirements

**For Warranty consideration, you must include your original sales receipt verifying the proof-of-purchase date.** Provided warranty conditions have been met, your Product will be serviced or replaced free of charge. Service or replacement decisions are at the sole discretion of Horizon.

## Non-Warranty Service

**Should your service not be covered by warranty, service will be completed and payment will be required without notification or estimate of the expense unless the expense exceeds 50% of the retail purchase cost.** By submitting the item for service you are agreeing to payment of the service without notification. Service estimates are available upon request. You must include this request with your item submitted for service. Non-warranty service estimates will be billed a minimum of ½ hour of labor. In addition you will be billed for return freight. Horizon accepts money orders and cashier's checks, as well as Visa, MasterCard, American Express, and Discover cards. By submitting any item to Horizon for service, you are agreeing to Horizon's Terms and Conditions found on our website [http://www.horizonhobby.com/content/\\_service-center\\_render-service-center](http://www.horizonhobby.com/content/_service-center_render-service-center).

**ATTENTION: Horizon service is limited to Product compliant in the country of use and ownership. If received, a non-compliant Product will not be serviced. Further, the sender will be responsible for arranging return shipment of the un-serviced Product, through a carrier of the sender's choice and at the sender's expense. Horizon will hold non-compliant Product for a period of 60 days from notification, after which it will be discarded.**

## Warranty and Service Contact Information

Country of Purchase	Horizon Hobby	Contact Information	Address
United States of America	Horizon Service Center (Repairs and Repair Requests)	servicecenter.horizonhobby.com/ RequestForm/	4105 Fieldstone Rd Champaign, Illinois, 61822 USA
	Horizon Product Support (Product Technical Assistance)	www.quickbase.com/db/ bghj7ey8c?a=GenNewRecord 888-959-2304	
	Sales	sales@horizonhobby.com 888-959-2304	
United Kingdom	Service/Parts/Sales: Horizon Hobby Limited	sales@horizonhobby.co.uk +44 (0) 1279 641 097	Units 1-4 , Ployters Rd, Staple Tye Harlow, Essex, CM18 7NS, United Kingdom
Germany	Horizon Technischer Service Sales: Horizon Hobby GmbH	service@horizonhobby.de +49 (0) 4121 2655 100	Christian-Junge-Straße 1 25337 Elmshorn, Germany
France	Service/Parts/Sales: Horizon Hobby SAS	infofrance@horizonhobby.com +33 (0) 1 60 18 34 90	11 Rue Georges Charpak 77127 Lieusaint, France
China	Service/Parts/Sales: Horizon Hobby – China	info@horizonhobby.com.cn +86 (021) 5180 9868	Room 506, No. 97 Changshou Rd. Shanghai, China 200060

### FCC Information

This device complies with part 15 of the FCC rules. Operation is subject to the following two conditions: (1) This device may not cause harmful interference, and (2) this device must accept any interference received, including interference that may cause undesired operation.



**CAUTION:** Changes or modifications not expressly approved by the party responsible for compliance could void the user's authority to operate the equipment.

This product contains a radio transmitter with wireless technology which has been tested and found to be compliant with the applicable regulations governing a radio transmitter in the 2.400GHz to 2.4835GHz frequency range.

### IC Information

This device complies with Industry Canada license-exempt RSS standard(s). Operation is subject to the following two conditions: (1) this device may not cause interference, and (2) this device must accept any interference, including interference that may cause undesired operation of the device.

### Compliance Information for the European Union

#### Declaration of Conformity

(in accordance with ISO/IEC 17050-1)

No. HH2014092601

Product(s): 180 CFX BNF Basic

Item Number(s): BLH3450

Equipment class: 1

The object of declaration described above is in conformity with the requirements of the specifications listed below, following the provisions of the European R&TTE Directive 1999/5/EC and EMC Directive 2004/108/EC:

**EN301 489-1 V1.9.2: 2012**

**EN301 489-17 V2.1.1: 2009**

**EN55022:2010 + AC:2011**

**EN55024:2010**



Signed for and on behalf of:

Horizon Hobby, LLC

Champaign, IL USA

September 26, 2014

Mike Dunne  
Executive Vice President  
Product Divisions  
Horizon Hobby, LLC

#### Instructions for disposal of WEEE by users in the European Union



This product must not be disposed of with other waste. Instead, it is the user's responsibility to dispose of their waste equipment by handing it over to a designated collections point for the recycling of waste electrical and electronic equipment. The separate collection and recycling of your waste equipment at the time of disposal will help to conserve natural resources and ensure that it is recycled in a manner that protects human health and the environment. For more information about where you can drop off your waste equipment for recycling, please contact your local city office, your household waste disposal service or where you purchased the product.

©2014 Horizon Hobby, LLC.

Blade, E-flite, Dynamite, Prophet, AS3X, DSM, DSM2, DSMX, AirWare, ModelMatch, the BNF logo and the Horizon Hobby logo are trademarks or registered trademarks of Horizon Hobby, LLC.

The Spektrum trademark is used with permission of Bachmann Industries, Inc.

All other trademarks, service marks or logos are property of their respective owners.

Patents pending.

Created 10/14

44403.3

BLH3450