

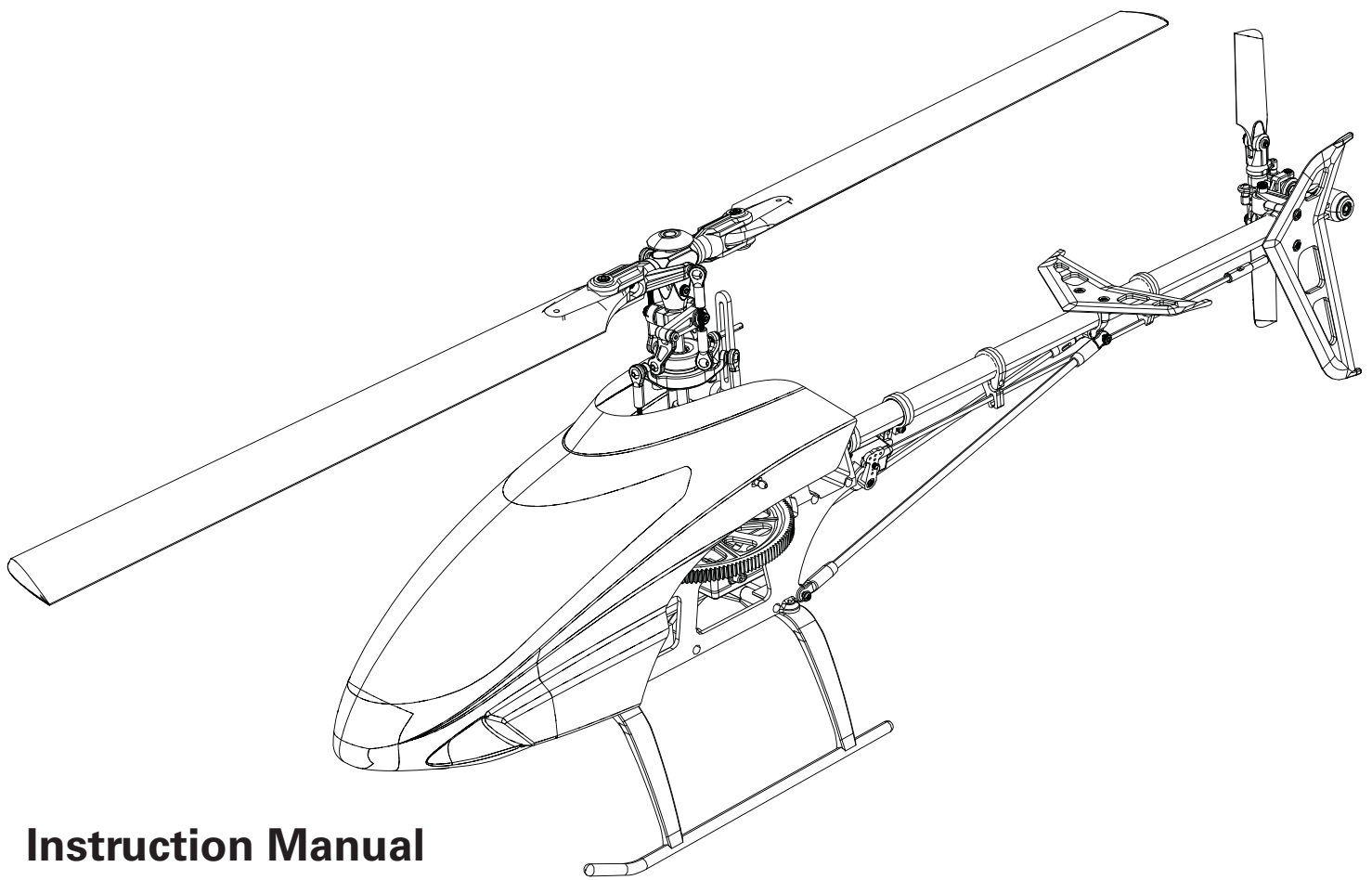

BLADE[®] 300 X



**Instruction Manual
Bedienungsanleitung
Manuel d'utilisation
Manuale di Istruzioni**

SPEKTRUM™ DSMX® CONTROL • BEASTX™ FLYBARLESS TECHNOLOGY



NOTICE

All instructions, warranties and other collateral documents are subject to change at the sole discretion of Horizon Hobby, Inc. For up-to-date product literature, visit horizonhobby.com and click on the support tab for this product.

Meaning of Special Language

The following terms are used throughout the product literature to indicate various levels of potential harm when operating this product:

NOTICE: Procedures, which if not properly followed, create a possibility of physical property damage AND a little or no possibility of injury.

CAUTION: Procedures, which if not properly followed, create the probability of physical property damage AND a possibility of serious injury.

WARNING: Procedures, which if not properly followed, create the probability of property damage, collateral damage, and serious injury OR create a high probability of superficial injury.



WARNING: Read the ENTIRE instruction manual to become familiar with the features of the product before operating. Failure to operate the product correctly can result in damage to the product, personal property and cause serious injury.

This is a sophisticated hobby product. It must be operated with caution and common sense and requires some basic mechanical ability. Failure to operate this Product in a safe and responsible manner could result in injury or damage to the product or other property. This product is not intended for use by children without direct adult supervision. Do not attempt disassembly, use with incompatible components or augment product in any way without the approval of Horizon Hobby, Inc. This manual contains instructions for safety, operation and maintenance. It is essential to read and follow all the instructions and warnings in the manual, prior to assembly, setup or use, in order to operate correctly and avoid damage or serious injury.

General Safety Precautions and Warnings

Age Recommendation: Not for children under 14 years. This is not a toy.

- Always keep a safe distance in all directions around your model to avoid collisions or injury. This model is controlled by a radio signal subject to interference from many sources outside your control. Interference can cause momentary loss of control.
- Always operate your model in open spaces away from full-size vehicles, traffic and people.
- Always carefully follow the directions and warnings for this and any optional support equipment (chargers, rechargeable battery packs, etc.).
- Always keep all chemicals, small parts and anything electrical out of the reach of children.
- Always avoid water exposure to all equipment not specifically designed and protected for this purpose. Moisture causes damage to electronics.
- Never place any portion of the model in your mouth as it could cause serious injury or even death.
- Never operate your model with low transmitter batteries.

Battery Warnings

The Battery Charger included with your aircraft is designed to safely charge the Li-Po battery.



CAUTION: All instructions and warnings must be followed exactly. Mishandling of Li-Po batteries can result in a fire, personal injury, and/or property damage.

- By handling, charging or using the included Li-Po battery you assume all risks associated with lithium batteries.
- If at any time the battery begins to balloon or swell, discontinue use immediately. If charging or discharging, discontinue and disconnect. Continuing to use, charge or discharge a battery that is ballooning or swelling can result in fire.
- Only charge batteries that are cool to the touch.
- Always store the battery at room temperature in a dry area for best results.
- Always transport or temporarily store the battery in a temperature range of 40–120° F. Do not store battery or model in a car or direct sunlight. If stored in a hot car, the battery can be damaged or even catch fire.
- Always charge batteries away from flammable materials.
- NEVER USE AN Ni-Cd OR Ni-MH CHARGER. Failure to charge the battery with a compatible charger may cause fire resulting in personal injury and/or property damage.
- Never discharge Li-Po cells to below 3V under load.
- Never cover warning labels with hook and loop strips.
- Never charge batteries outside safe temperature range.
- Never charge batteries outside recommended levels.
- Never charge dead or damaged batteries.
- Never leave charging batteries unattended.
- Never allow batteries or battery packs to come into contact with moisture at any time.

Introduction

The Blade® 300 X features the Spektrum® AR7200BX 7-channel receiver with integrated BeastX™ flybarless technology. The Spektrum AR7200BX provides maximum precision, stability, and control for advanced 3D maneuvers. A new flybarless rotorhead design combined with the Spektrum AR7200BX results in simplified setup, easier maintenance and a lighter helicopter. The Blade 300 X also includes a high-performance 320H brushless motor, digital servos and main blades designed to handle the rigors of 3D flybarless flight.

Read this manual thoroughly before your first flight. This manual contains important pre-flight information to help ensure your first flight is a great one.

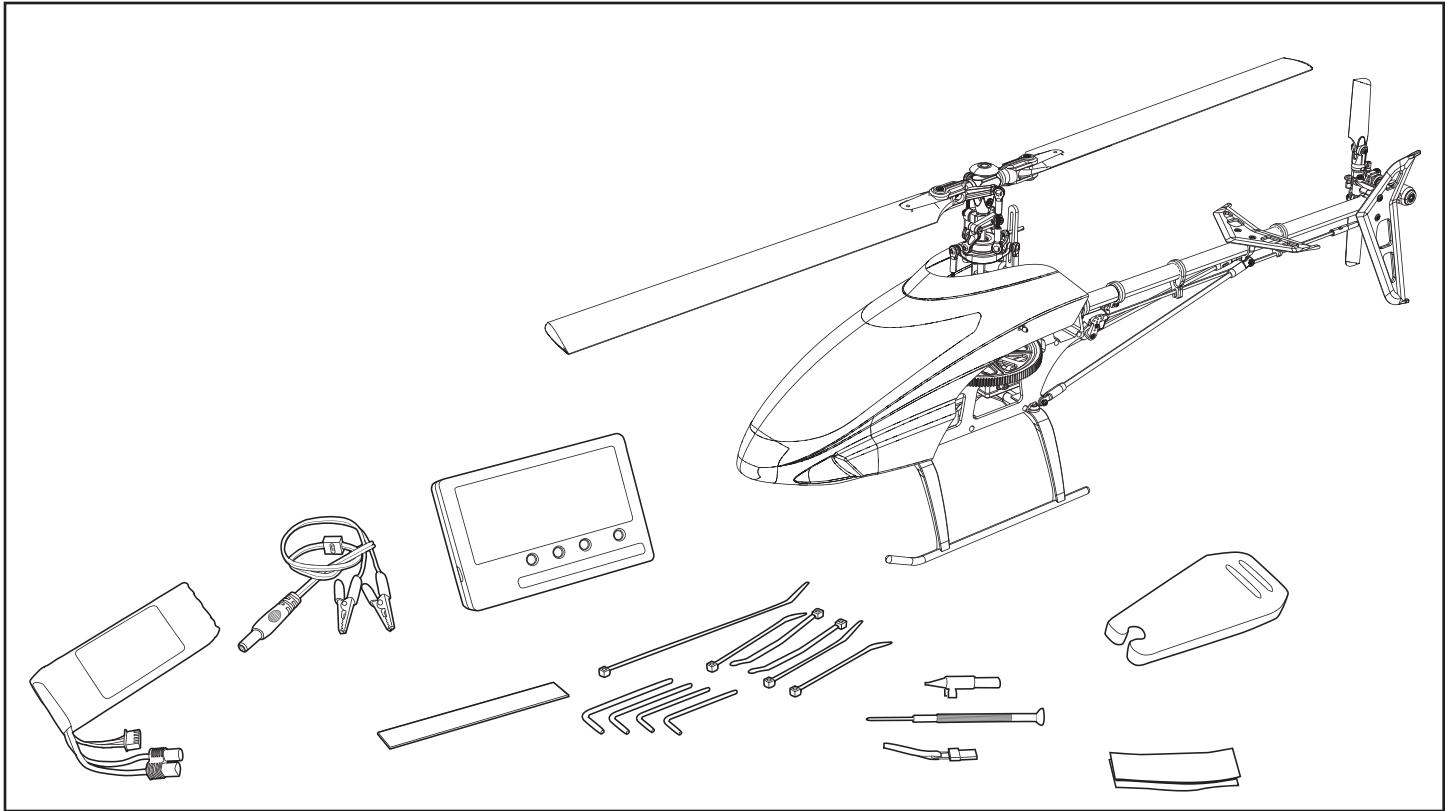

Table of Contents

Charging the Flight Battery	4
Battery Charging Codes	4
Low Voltage Cutoff (LVC)	4
Transmitter Setup	5
Transmitter and Receiver Binding.....	8
Throttle Hold.....	8
Installing the Flight Battery	8
Control Tests.....	9
Flying the Blade 300 X.....	10
Gyro Gain Adjustment	11
Blade Helicopter Belt Tension	11
Post-Flight Inspections and Maintenance	11
AR7200BX Default Blade 300 X Setup.....	12
AR7200BX Parameter Menu Tips	13
AR7200BX Fine-tuning and Adjustment.....	13
Blade 300 X Troubleshooting Guide.....	13
Limited Warranty	14
Warranty and Service Contact Information	15
Customer Service Information.....	15
Compliance Information for the European Union.....	15
Parts List	58
Optional Parts	60

Blade 300 X Specifications

Length	20.1 in (510mm)
Height	7.7 in (195mm)
Main Rotor Diameter	21.7 in (550mm)
Tail Rotor Diameter	5.5 in (140mm)
Flying Weight	17.3 oz (491 g)

Components

Motor	320H Brushless outrunner, 4500Kv (installed)
ESC	25-amp brushless (installed)
Battery	3S 11.1V 1350mAh 30C Li-Po (included)
Charger	DC Li-Po Balancing Charger (included)
Flybarless Unit	Spektrum AR7200BX with BeastX technology (installed)
Swash Servos	DS76 (installed)
Tail Servo	DS76T (installed)

To register your product online, visit www.bladehelis.com

Charging the Flight Battery

The Blade 300 X comes with a DC balancing charger and 3S Li-Po battery. Use only Horizon Hobby approved battery packs and chargers compatible with this product. Never leave the battery and charger unattended during the charging process. Failure to follow the instructions properly could result in a fire. When charging, make sure the battery is on a heat-resistant surface. Charge the flight battery before binding the aircraft or performing control tests.

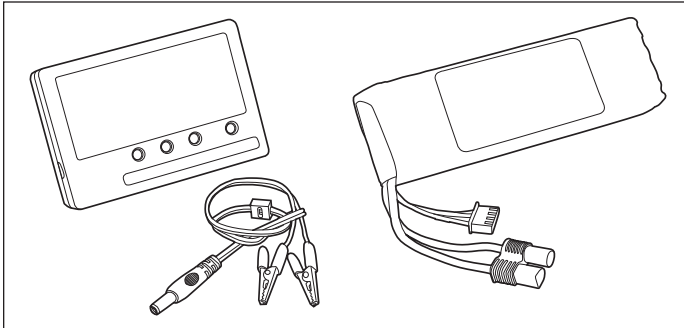

DC Li-Po Balancing Charger Features

- Charges 3-cell lithium polymer battery packs
- 1.8A charge rate
- LED charge status indicator
- LED cell balance indicator
- 12V alligator clip input cord

Specifications

- Input power: minimum 3A at 11.5–15V DC

3S 11.1V 1350mAh 30C Li-Po Battery Pack (E-flite EFLB13503S30)

The Blade 300 X 3S Li-Po battery pack features a balancing lead that allows you to safely charge your battery pack when used with the included Li-Po balancing charger. The included flight battery is safe to charge up to 3C (4.05A).

CAUTION: The balance connector must be inserted into the correct port of your charger prior to charging.

The Battery Charging Process

1. Charge only batteries that are cool to the touch and are not damaged. Inspect the battery to make sure it is not damaged e.g., swollen, bent, broken or punctured.
2. Connect the charger to a 12V power source, noting proper polarity.
3. The CHARGE STATUS LED glows solid red.
4. Connect the battery balance lead to the charger. The balance connector is keyed to prevent reverse polarity.
5. The CELL STATUS LEDs glow solid green or yellow and the CHARGE STATUS LED glows solid red when the battery is charging.
6. Charging is complete when all LEDs glow solid red.
7. Always unplug the battery from the charger immediately upon completion of charging.

CAUTION: Only use a charger specifically designed to charge a Li-Po battery. Failure to do so could result in fire causing injury or property damage.

CAUTION: Do not exceed manufacturer's recommended charge rate.

Battery Charging Codes

Cell Status LEDs	Charge Status LED	Instruction
Off	Red Solid	Battery charger is powered. Li-Po battery is not connected.
Yellow	Red Solid	Li-Po battery is connected. Charger is balancing the battery pack cells
Green	Red Solid	Li-Po battery is connected and charging
Red	Red Solid	Li-Po battery is connected and charging is complete
Off	Blinking Red	No Li-Po battery connected: Voltage is outside the input voltage range Li-Po battery connected: At least one battery cell voltage is below 2.6V

Low Voltage Cutoff (LVC)

Once the battery reaches 9V under load, the ESC will continuously lower power supplied to the motor until complete shutdown occurs. This helps prevent over-discharge of the Li-Po battery. Land immediately once the ESC activates LVC. Continuing to fly after LVC can damage the battery, cause a crash or both. Crash damage and batteries damaged due to over-discharge are not covered under warranty.

Repeatedly flying the helicopter until LVC activates will damage the helicopter battery.

Disconnect and remove the Li-Po battery from the aircraft after use to prevent trickle discharge. During storage, make sure the battery charge does not fall below 3V per cell.

Transmitter Setup

Program your transmitter before attempting to bind or fly the helicopter. Transmitter programming values are shown below for the Spektrum DX6i, DX7/DX7se, DX7s and DX8. The Spektrum model files for AirWare™ transmitters are also available for download online in the Spektrum Community.

NOTICE: When using a Futaba transmitter with a Spektrum DSM module, you must reverse the throttle channel.

Spektrum DX6i

SETUP LIST				ADJUST LIST							
Model Type	Reverse	Swash Type	Timer	D/R		Expo	TRAVEL ADJUST			SUB-TRIM*	
HELI	THRO—N	1 Servo 90 Degree	Type—Down	AILE 0	100%	INH	THRO	100%	THRO	0	
	AILE—N		Time—4:00	ELEV 0	100%	INH	AILE	100%	AILE	0*	
	ELEV—R		Switch—Trainer	RUDD 0	100%	INH	ELEV	100%	ELEV	0*	
	RUDD—R			AILE 1	85%	INH	RUDD	100%	RUDD	0*	
	GYRO—N			ELEV 1	85%	INH	GYRO	100%	GYRO	0	
	PITC—N			RUDD 1	85%	INH	PITC	100%	PITC	0	

GYRO				THRO CUR					PITC CUR						
Rate	SW-F. Mode			L	2	3	4	H	L	2	3	4	H		
0	77.0%	NORM	0	NORM	0%	25%	50%	60%	70%	NORM	30%	40%	50%	75%	100%
1	77.0%	STUNT	1	STUNT	75%	75%	75%	75%	75%	STUNT	0%	25%	50%	75%	100%
				HOLD	10%	10%	10%	10%	10%	HOLD	0%	25%	50%	75%	100%

SWASH MIX	
INHIBIT	

* Never use sub-trims or trims on AILE, ELEV or RUDD channels with the AR7200BX.

Spektrum DX7/DX7se

SYSTEM LIST				ADJUST LIST										
Model Type	Swash Type	Input Select		POS-0			POS-1			AUTO			D/R	EXP
HELI	1 Servo Norm	AUX2 INH	GEAR GYRO	AILE	ELEV	RUDD	AILE	ELEV	RUDD				NORM	INH
				EXP LIN	EXP LIN	EXP LIN	EXP LIN	EXP LIN	EXP LIN				ST-1	INH
				D/R 100%	D/R 100%	D/R 100%	D/R 85%	D/R 85%	D/R 100%				ST-2	INH
													HOLD	INH

REVERSING SW								THRO CURVE					SWASH MIX			
THRO	AILE	ELEV	RUDD	GEAR	PIT	AUX2		L	1	2	3	H	N/A			
N	N	R	R	N	R	N		NORM	0%	25%	50%	60%	70%			
								ST-1	100%	70%	60%	70%	100%			
								ST-2	75%	75%	75%	75%	75%			

SUB-TRIM*		TRAVEL ADJUST		PITCH CURVE					THRO HOLD			
THRO	0	THRO	AILE	L	1	2	3	H	HOLD POS 0.0%			
AILE	0*	H 100%	L 100%	NORM	30%	40%	50%	75%	100%	SW RUDD D/R		
ELEV	0*	L 100%	R 100%	ST-1	0%	25%	50%	75%	100%			
RUDD	0*			ST-2	0%	25%	50%	75%	100%			
GEAR	0	ELEV	RUDD	HOLD	0%	25%	50%	75%	100%			
PITC	0	D 100%	L 100%									
AUX2	0	U 100%	R 100%									
		GEAR	PIT									
		+ 100%	H 100%									
		- 100%	L 100%									
		AUX2										
		+ 100%										
		- 100%										

GYRO SENS				TIMER	
AUTO	F. MODE			DOWN-T	
		NORM	0	4:00	
0	77.0%	STNT	1		
1	77.0%	HOLD	0		

* Never use sub-trims or trims on AILE, ELEV or RUDD channels with the AR7200BX.

Transmitter Setup

Spektrum DX7s

SYSTEM LIST

Model Type	Swash Type	Switch Select	F Mode Setup	Warnings	Frame Rate
Helicopter	1 Servo Normal	All Switches INH	Flight Mode — F Mode	Throttle — Over 10	11ms
			Hold — Hold	Stunt 1—Active	DSMX
				Hold—Active	
				Alarm—Tone/Vibe	

FUNCTION LIST

SERVO SETUP

TRAVEL			SUB TRIM*	REVERSE	
THROTTLE	100	100	THROTTLE 0	THROTTLE	N
AILERON	100	100	AILERON 0*	AILERON	N
ELEVATOR	100	100	ELEVATOR 0*	ELEVATOR	R
RUDDER	100	100	RUDDER 0*	RUDDER	R
GYRO	100	100	GYRO 0	GYRO	N
PITCH	100	100	PITCH 0	PITCH	R
AUX2	100	100	AUX2 0	AUX2	N

D/R AND EXPO

	POS	D/R	D/R	EXPO	SW
AILERON	0	100	100	0	AILE D/R
AILERON	1	85	85	0	AILE D/R
ELEVATOR	0	100	100	0	ELEV D/R
ELEVATOR	1	85	85	0	ELEV D/R
RUDDER	0	100	100	0	RUDD D/R
RUDDER	1	85	85	0	RUDD D/R

THROTTLE CUT

INHIBIT

GOVERNOR

SW-INHIBIT

SWASHPLATE

INHIBIT

THROTTLE CURVE

	LOW	25%	50%	75%	HIGH	EXPO
N	0	25	50	60	70	INH
1	75	75	75	75	75	INH
H	0	0	0	0	0	INH

PITCH CURVE

	LOW	25%	50%	75%	HIGH	EXPO
N	30	40	50	75	100	INH
1	0	25	50	75	100	INH
H	0	25	50	75	100	INH

GYRO

SW	F Mode
CH	Gear
NORMAL/POS 0	54
STUNT 1/POS 1	54
HOLD	54

TAIL CURVE

	LOW	25%	50%	75%	HIGH	EXPO
N	0	0	0	0	0	INH
1	0	0	0	0	0	INH
H	0	0	0	0	0	INH

TIMER

MODE	Countdown
TIME	4:00 Tone/Vibe
START	Throttle Out
POS	25

* Never use sub-trims or trims on AILE, ELEV or RUDD channels with the AR7200BX.

Transmitter Setup

Spektrum DX8

SYSTEM LIST

Model Type	Swash Type	Switch Select	F Mode Setup	Trim Step	Warnings	Frame Rate
Helicopter	1 Servo Normal	All Switches INH	Flight Mode — F Mode	THR 5	Throttle —Over 10	11ms
			Hold — Hold	AIL** 0	Stunt 1—Act	DSMX
				ELE** 0	Stunt 2—Act	
				RUD** 0	Hold—Act	
				R TRIM 0	Alarm—Tone/Vibe	
				L TRIM 0		
				TYPE Common		

**Changing trim step to zero disables the trim for that channel.

FUNCTION LIST

SERVO SETUP

TRAVEL			SUB TRIM*			REVERSE			SPEED
THROTTLE	100	100	THROTTLE	0		THROTTLE	N		THROTTLE NORM
AILERON	100	100	AILERON	0*		AILERON	N		AILERON NORM
ELEVATOR	100	100	ELEVATOR	0*		ELEVATOR	R		ELEVATOR NORM
RUDDER	100	100	RUDDER	0*		RUDDER	R		RUDDER NORM
GYRO	100	100	GYRO	0		GYRO	N		GYRO NORM
PITCH	100	100	PITCH	0		PITCH	R		PITCH NORM
AUX2	100	100	AUX2	0		AUX2	N		AUX2 NORM
AUX3	100	100	AUX3	0		AUX3	N		AUX3 NORM

THROTTLE CUT

INHIBIT

GOVERNOR

INHIBIT

SWASHPLATE

INHIBIT

D/R AND EXPO

	POS	D/R	D/R	EXPO	SW
AILERON	0	100	100	0	AILE D/R
AILERON	1,2	85	85	0	AILE D/R
ELEVATOR	0	100	100	0	ELEV D/R
ELEVATOR	1,2	85	85	0	ELEV D/R
RUDDER	0	100	100	0	RUDD D/R
RUDDER	1,2	85	85	0	RUDD D/R

THROTTLE CURVE

	LOW	25%	50%	75%	HIGH	EXPO
N	0	25	50	60	70	INH
1	100%	70%	60%	70%	100%	INH
2	75	75	75	75	75	INH
H	0	0	0	0	0	INH

GYRO

SW	F Mode
CH	Gear
NORMAL/POS 0	54
STUNT 1/POS 1	54
STUNT 2/POS 2	54
HOLD	54

PITCH CURVE

	LOW	25%	50%	75%	HIGH	EXPO
N	30	40	50	75	100	INH
1	0	25	50	75	100	INH
2	0	25	50	75	100	INH
H	0	25	50	75	100	INH

TAIL CURVE

	LOW	25%	50%	75%	HIGH	EXPO
N	0	0	0	0	0	INH
1	0	0	0	0	0	INH
2	0	0	0	0	0	INH
H	0	0	0	0	0	INH

TIMER

MODE	Countdown
TIME	4:00 Tone/Vibe
START	Throttle Out
POS	25

* Never use sub-trims or trims on AILE, ELEV or RUDD channels with the AR7200BX.

Transmitter and Receiver Binding

Binding is the process of programming the receiver to recognize the GUID (Globally Unique Identifier) code of a single specific transmitter. You need to 'bind' your chosen Spektrum™ DSM2/DSMX technology equipped aircraft transmitter to the receiver for proper operation.

Binding Procedure

1. Program your transmitter using the Transmitter Setup found in this manual.
2. Insert the bind plug in the BND/DAT port on the receiver.
3. Connect the flight battery to the ESC. The H menu LED should be flashing, indicating the AR7200BX is in bind mode.
4. Move the throttle stick to the desired failsafe position (low throttle position in normal mode).
5. Follow the procedures of your specific transmitter to enter Bind Mode. The system will connect within a few seconds. Once connected, the H LED will turn off and the AR7200BX will start the initialization process.
6. When the initialization process is complete, the Status LED light will come ON solid BLUE.
7. Disconnect the flight battery and remove the bind plug from the AR7200BX. Store the bind plug in a convenient place.

NOTICE: Remove the bind plug to prevent the system from entering bind mode the next time the power is turned on.

If you encounter problems, obey binding instructions and refer to transmitter troubleshooting guide for other instructions. If needed, contact the appropriate Horizon Product Support office.

For a list of compatible DSM transmitters, please visit www.bindnfly.com.

Throttle Hold

Throttle hold only turns off the motor on an electric helicopter. You must maintain pitch and direction control.

The blades will spin if throttle hold is OFF. For safety, turn throttle hold ON any time you need to touch the helicopter or check the direction controls.

Throttle hold is also used to turn off the motor if the helicopter is out of control, in danger of crashing, or both.

Please refer to your transmitter manual for more information on programming throttle hold.

Installing the Flight Battery

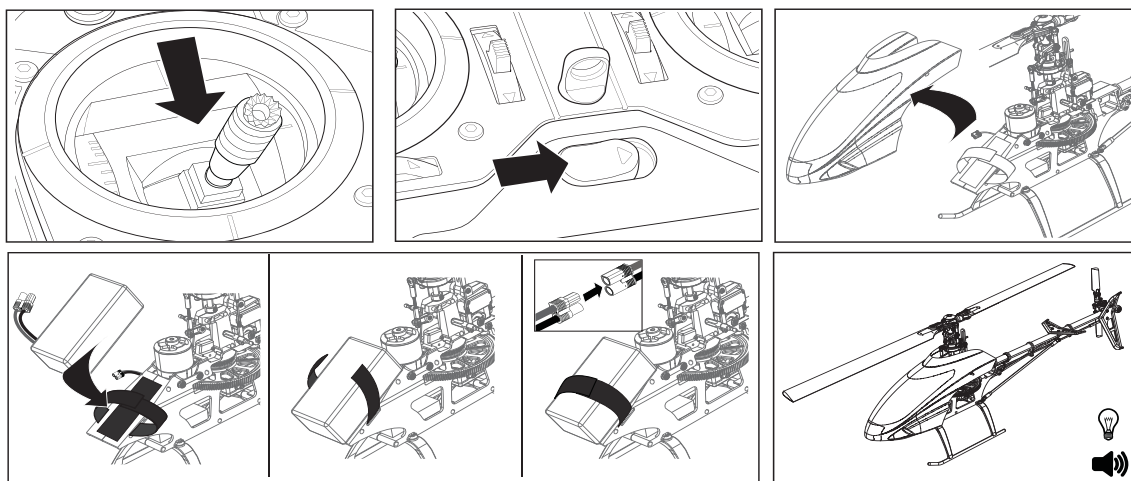

1. Lower the throttle.
2. Power on the transmitter.
3. Center the throttle trim.
4. To allow the ESC to arm and to keep rotors from initiating at startup, turn on throttle hold and normal flight mode before connecting the flight battery. Please refer to your transmitter manual for more information on programming throttle hold and normal flight mode.
5. Attach hook material to the helicopter frame and loop material to the battery.
6. Install the flight battery on the helicopter frame. Secure the flight battery with a hook and loop strap. Connect the battery cable to the ESC.

CAUTION: Always keep the power lead positioned AWAY from the elevator servo. Failure to do so could cause the lead to get caught and will result in crash causing property damage and injury.

CAUTION: Make sure the flight battery does not come in contact with the motor. Failure to do so will cause the motor, ESC and battery to overheat, resulting in crash, causing property damage and injury.

7. Do not move the helicopter until the AR7200BX initializes. The swashplate will move up and down indicating that the unit is ready. The AR7200BX will also emit a solid BLUE Status LED when it is ready.
8. The helicopter motor will emit 2 tones, indicating the ESC is armed.

CAUTION: Always disconnect the Li-Po battery from the aircraft receiver when not flying to avoid over-discharging the battery. Batteries discharged to a voltage lower than the lowest approved voltage may become damaged, resulting in loss of performance and potential fire when batteries are charged.

Control Tests

Rudder and Cyclic Gyro Test

Rudder

1. Power on the transmitter.
2. Turn TH HOLD ON and put the transmitter into normal mode.
NOTICE: Do not allow the helicopter to move until the Status LED is solid blue and all menu LEDs are OFF. The gyro will not operate correctly if the helicopter moves before the Status LED is solid blue.
3. Connect the helicopter battery to the ESC.
4. Move the rudder stick to the right. The tail rotor blades move as shown. If they do not move as shown, reverse the rudder channel in the transmitter (refer to your transmitter manual for instructions).

5. Release the rudder control. Manually turn the helicopter nose to the left. The tail rotor blades automatically move as shown. If they do not move as shown, refer to the AR7200BX manual for information on reversing the tail sensor direction (Setup menu point F).

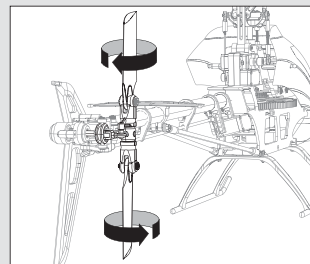

Cyclic

When using a flybarless rotor head, you are controlling rotational rates while the AR7200BX controls the servos. You are not directly controlling the servos with the transmitter.

It is normal for the swashplate to slowly move back to its original position after a stick input and for the servos to not move at the same speed as your control sticks.

1. Tilt the helicopter forward. The swashplate should tilt backward.
2. Tilt the helicopter backward. The swashplate should tilt forward.
3. Roll the helicopter left. The swashplate should roll right.
4. Roll the helicopter right. The swashplate should roll left.
5. If the swashplate does not move in the correct direction, you will need to reverse the cyclic sensor direction. Refer to the AR7200BX manual for more information (Setup menu point M).



CAUTION: You must complete the Rudder and Cyclic tests prior to flight. Failure to complete the tests and ensure the sensor directions are not reversed can cause the helicopter to crash, resulting in property damage and injury.

Cyclic and Collective Control Test

Turn on Throttle Hold when doing the control tests

Elevator

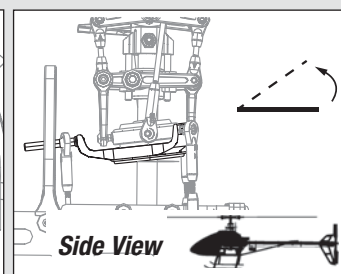
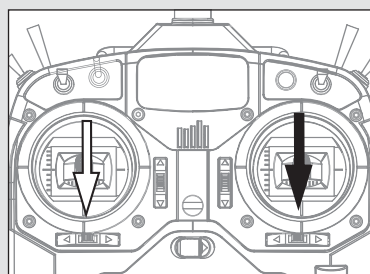
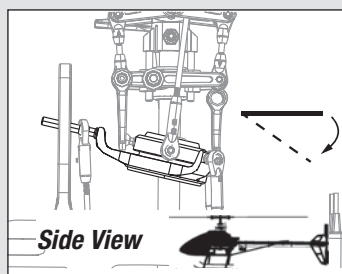
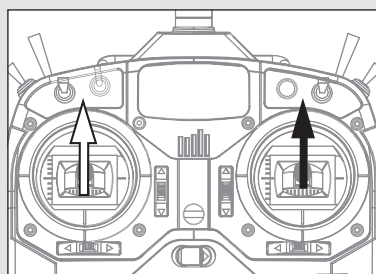

Aileron

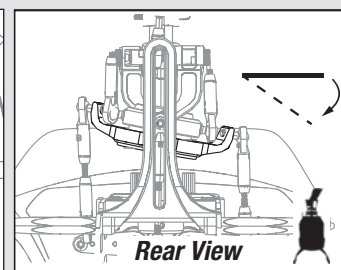
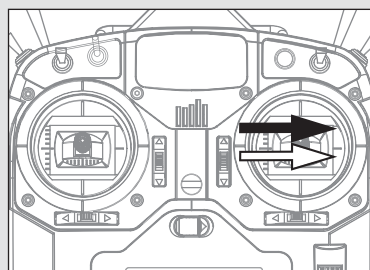
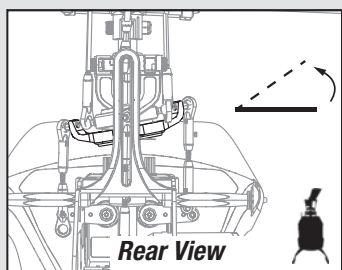
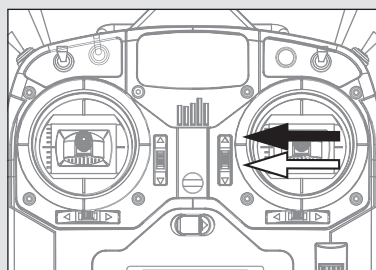

Collective Pitch

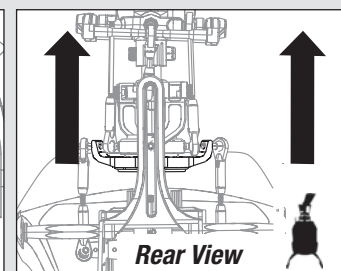
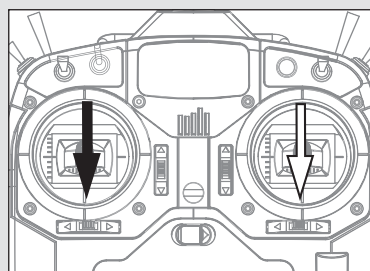
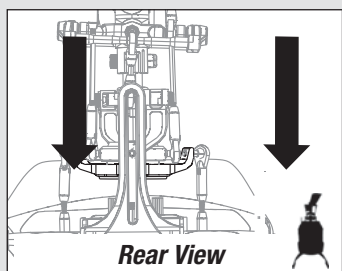
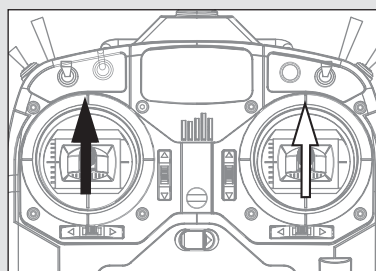

MODE 2 ↑ MODE 1 ↑

Motor Control Test

Place the helicopter outdoors on a clean, flat and level surface (concrete or asphalt) free of obstructions. Always stay clear of moving rotor blades.

- 1 The motor beeps twice when the helicopter's ESC arms properly. Before you continue, confirm that TH HOLD is ON.



WARNING: The motor will spin when throttle is increased while TH HOLD is OFF.

2. Check the swashplate directions to ensure they are moving in the correct direction. Please refer to the diagrams above for reference.



WARNING: Stay at least 30 feet (10 meters) away from the helicopter when the motor is running. Do not attempt to fly the helicopter at this time.

3. Ensure the throttle is lowered completely. Turn throttle hold off at this time and confirm the transmitter is still set to normal flight mode. Slowly increase the throttle until the blades begin to spin. The main blades spin clockwise when viewing the helicopter from the top. The tail rotor blades spin counterclockwise when viewing the helicopter from the right-hand side.

NOTICE: If the main rotor blades are spinning counterclockwise, reduce the throttle to low immediately. Turn throttle hold on. Disconnect the battery from the helicopter and reverse any two motor wire connections to the ESC and repeat the motor control test.

Blade 300 X Pre-Flight Checklist

- Check all screws to ensure that they are tight
- Check belt tension to ensure that it is not too tight or too loose
- Check main and tail blades to ensure they are not damaged
- Check all links to make sure they move freely, but do not pop off easily
- Check that flight battery and transmitter battery are fully charged
- Check all wires to ensure that they are not cut, pinched, or chafed and are properly secured
- Check all wire connections
- Check gears to make sure no teeth are missing
- Do a complete control test
- Check that the servos are functioning properly
- Check to make sure the flight battery is properly secured
- Check to make sure the AR7200BX is properly secured

Flying the Blade 300 X

- Always keep aircraft in sight and under control.
- Always turn on throttle hold at loss of control or rotor strike.
- Always use fully charged batteries.
- Always keep transmitter powered on while aircraft is powered.
- Always remove batteries before disassembly
- Always keep moving parts clean.
- Always keep parts dry.
- Always let parts cool after use before touching.
- Always remove batteries after use.
- Always keep people and pets at least 30 feet away when the flight battery is connected.
- Never operate aircraft with damaged wiring.
- Never touch moving parts.

Consult local laws and ordinances before choosing a location to fly your aircraft.

Select a large, open area away from people and objects. Your first flights should be outdoors in low-wind conditions. Always stay at least 30 feet (10 meters) away from the helicopter when it is flying.

The Blade 300 X is intended to be flown outdoors or inside a large gymnasium.



CAUTION: The Blade 300 X is intended for pilots with experience flying aerobatic, collective pitch helicopters. The Blade 300 X is more responsive than other Blade helicopters, such as the Blade SR. If you are not an experienced 3D or collective pitch helicopter pilot, do not attempt to fly this product.

Takeoff

Deliberately increase throttle and establish a hover at least 24" (0.6 meter) high, outside of ground effect.



CAUTION: Do not give any aileron, elevator or rudder commands before takeoff or the helicopter may crash during takeoff.

Flying

The helicopter lifts off the ground when the rotor head reaches a suitable speed. Establish a low-level hover outside of ground effect to verify proper operation of your helicopter. You must not set any trim; the flybarless design of the Blade 300 X renders trim unnecessary. Setting trim or sub-trim can cause an unwanted drift or rotation of the helicopter.

First flights should be performed in normal mode and low cyclic and rudder dual rates until you are familiar with the flying manner of the Blade 300 X. Discover the rates that fit your flying style.



CAUTION: Always fly the helicopter with your back to the sun and the wind to prevent loss of flight control.

Landing

Establish a low level hover. Deliberately lower the throttle until the helicopter lands. Do not give any aileron, elevator or rudder commands when the helicopter is landing.

When the helicopter is in stunt mode:

- The rotor head speed is constant.
- The main rotor will increase negative pitch as the throttle/collective stick is moved from the middle stick position to the low stick position. Negative pitch allows the helicopter to fly upside down and perform aerobatics.

Change between stunt and idle up modes in a hover with the throttle near the hovering stick position.

The helicopter may go up or down when you change between modes due to the difference in the throttle and pitch curves.

If the cyclic control is too slow or too fast, adjust the transmitter dual rates, expo or throttle curve to fit your liking.

Gyro Gain Adjustment

- If the tail wags or oscillates, lower the gain on the gyro.

On your transmitter's gyro menu, decrease the gyro gain values a small amount until the helicopter is stable within a particular flight mode

- If the tail is drifting while hovering, increase the gain on the gyro.

On your transmitter, increase the gyro gain values a small amount at a time until the tail starts to wag/oscillate. Afterwards, reduce the gain until the tail stops wagging/oscillating within a particular flight mode.

Blade Helicopter Belt Tension

Belt tension that is too tight results in loss of power and causes the belt to wear more quickly. Tension that is too loose can cause belt damage and loss of tail rotor control in flight.

To check for proper belt tension:

1. View the tail rotor drive belt through the opening at the back of the main frame.
2. Use a hex wrench or standard screwdriver to compress the belt through the opening.
3. Apply light pressure on the belt, compressing the belt toward the left side of the tail boom.
4. The belt tension is correct if the compressed side of the belt reaches approximately halfway to the opposite side of the belt.
 - a. *If the compressed side of the belt reaches farther than halfway to the other side of the belt, the tension is too loose.*
 - b. *If the compressed side of the belt does not reach halfway to the other side of the belt, the tension is too tight.*

To adjust belt tension:

1. Loosen the two horizontal stabilizer screws.
2. Loosen the four screws at the back of the main frame.
3. Slide the boom forward or aft to adjust the belt tension.
4. When the belt tension is properly adjusted, tighten the four screws at the back of the frame.
5. Tighten the horizontal stabilizer screws.

Post-Flight Inspections and Maintenance

Ball Links	Make sure the plastic ball link holds the control ball, but is not tight (binding) on the ball. When a link is too loose on the ball, it can separate from the ball during flight and cause a crash. Replace worn ball links before they fail.
Cleaning	Make sure the battery is not connected before cleaning. Remove dust and debris with a soft brush or a dry lint free cloth.
Bearings	Replace bearings when they become notchy (sticky in places when turning) or draggy.
Wiring	Make sure the wiring does not block moving parts. Replace damaged wiring and loose connectors.
Fasteners	Make sure there are no loose screws, other fasteners or connectors. Do not over tighten metal screws in plastic parts. Tighten screw so parts are mated together, then turn screw only 1/8th of a turn more.
Rotors	Make sure there is no damage to rotor blades and other parts which move at high speed. Damage to these parts includes cracks, burrs, chips or scratches. Replace damaged parts before flying.
Gyro	Make sure the AR7200BX is securely attached to the frame. Replace the double-sided tape when necessary. The helicopter will crash if the AR7200BX separates from the helicopter frame.

SETUP MENU *Menu LED solid*

Status-LED:		OFF	Purple	Red Flashing	Red Solid	Blue Flashing	Blue Solid
A	Mounting orientation				upright (vertical)		flat (horizontal)*
B	Swashplate servo— frequency	User defined	50Hz	65Hz	120Hz	165Hz	200Hz*
C	Tail servo— center position pulse length	User defined	960µs		760µs		1520µs*
D	Tail servo— frequency	User defined	50Hz	165Hz	270*Hz	333Hz	560Hz
E	Tail servo— rotor endpoints	Tail stick—move to right endpoint and wait/left endpoint and wait					
F	Tail— sensor direction				normal		reversed*
G	Swashplate— servo centering	Reference position	ELE center pos.		AIL center pos.		PIT center pos.
H	Swashplate— mixer	User defined	mechanical	90°	120°*	140°	140° (1=1)
I	Swashplate— servo directions	nor rev rev	nor nor rev*		nor rev nor		nor nor nor
J	Swashplate— cyclic pitch geometry	Aileron stick—adjust 6° cyclic pitch on the roll axis (blades aligned with fuselage)					
K	Collective pitch range	Collective stick on max and min position and use tail stick to adjust desired pitch. Stock settings provide +/- 12 degrees of collective pitch.					
L	Swashplate— cyclic limit	Move aileron, elevator and pitch sticks – adjust max limits with tail stick					
M	Swashplate— sensor directions	rev rev	rev nor		nor rev		nor nor*
N	Pirouette optimization direction				normal		reversed*

PARAMETER MENU *Menu LED is flashing quickly*

Status-LED:		OFF	Purple	Red Flashing	Red Solid	Blue Flashing	Blue Solid
A	Swashplate— cyclic center adjustment	Aileron and elevator stick – reset with tail stick					
B	Control behavior	User defined	normal	sport	pro	extreme	transmitter*
C	Swashplate— pitching up behavior	User defined	very low	low	medium*	high	very high
D	Tail— HeadingLock gain	User defined	very low	low	medium*	high	very high
E	Stick deadband	User defined	1	2*	3	4	5
F	Tail— torque precompensation IX)	User defined	off*	low—nor	high—nor	low—rev	high—rev
G	Cyclic response	User defined	normal	slightly increased*	increased	high	very high
H	Pitch boost	User defined	off*	low	medium	high	very high

*The AR7200BX included with your Blade 300 X helicopter is pre-programmed with these default settings. If you perform a factory reset on the included AR7200BX will default back to these default Blade 300 X helicopter settings.

To perform a Blade 300 X AR7200BX factory reset, enter any Setup menu and press the setup button for 10 seconds. After performing the factory reset, you will need to re-center the swashplate servos by using setup menu G.

If you update the firmware on the AR7200BX to non-Blade 300 X firmware: All Blade 300 X helicopter default settings will be deleted. You will need to complete the entire AR7200BX setup process before flying the helicopter again. Please refer to the Spektrum AR7200BX instruction manual included with your helicopter for more information.

AR7200BX Parameter Menu Tips

Refer to the Spektrum AR7200BX manual to fine-tune the Blade 300 X to your flying and control style via the AR7200BX parameter menu.

If you would like to change the control behavior of the flybarless system to a pre-defined behavior in the AR7200BX, adjust parameter menu B (default behavior is transmitter).

If you would like to have the cyclic behavior to feel more linear OR more like a flybarred helicopter, increase the cyclic response by adjusting parameter menu G (default is 'slightly increased').

Refer to the Spektrum AR7200BX manual for specific details on each parameter.

AR7200BX Fine-tuning and Adjustment

Observed Behavior	Suggested Adjustment
Cyclic response is too slow or too fast	Adjust dual rates to fit your flying style. Refer to your transmitter instruction manual for more information
	Adjust the control behavior parameter in the AR7200BX to fit your flying style.
Control inputs feel delayed	Increase Dial 2 on the AR7200BX
The helicopter seems to overshoot control input and then return	Decrease Dial 2 on the AR7200BX
The helicopter tail stops too abruptly	Decrease Dial 3 on the AR7200BX
The helicopter tail does not stop precisely	Increase Dial 3 on the AR7200BX
	Increase the rudder gain in your transmitter
	Adjust the rudder heading lock gain parameter in the AR7200BX
	Make sure the tail drive belt tension is adjusted correctly

Blade 300 X Troubleshooting Guide

Problem	Possible Cause	Solution
Helicopter will not bind to the transmitter (during binding)	Low flight battery or transmitter battery voltage	Fully charge or replace the flight battery and/or transmitter batteries
	AR7200BX is not in bind mode	Make sure the bind plug is connected to the AR7200BX BND/DAT port
	Transmitter is not in bind mode	Refer to your transmitter's instruction manual for binding instructions
	Transmitter too close to the helicopter during binding process	Power off the transmitter. Move the transmitter to a larger distance from the helicopter. Disconnect and reconnect the flight battery to the helicopter and follow binding instructions.
Helicopter will not link to the transmitter (after binding)	Helicopter is bound to a different model memory (ModelMatch™ radios only)	Disconnect the flight battery. Select the correct model memory on the transmitter. Reconnect the flight battery
	Flight battery/Transmitter battery charge is too low	Replace or recharge batteries
AR7200BX will not initialize	The helicopter was moved during initialization	Lay the helicopter on its side during initialization if windy
	The transmitter is powered off	Power on the transmitter
	Controls are not centered	Center elevator, aileron and rudder controls. Make sure the throttle is at idle
Helicopter will not respond to the throttle but responds to other controls	Throttle not at idle and/or throttle trim is too high	Lower the throttle stick and throttle trim to the lowest settings
	The transmitter is not in normal mode or throttle hold is on	Make sure the transmitter is in normal mode and throttle hold is off
	The motor is not connected to the ESC or the motor wires are damaged	Connect the motor wires to the ESC and check motor wires for damage
	Flight battery charge is too low	Replace or recharge flight battery
	Throttle channel is reversed	Power down helicopter. Reverse the throttle channel on the transmitter
Helicopter power is lacking	Flight battery has low voltage	Fully charge the flight battery
	Flight battery is old or damaged	Replace the flight battery
	Flight battery cells are unbalanced	Fully charge the flight battery, allowing the charger time to balance the cells
	Excessive current is being drawn through the BEC	Check all servos and the helicopter motor for damage
	Tail drive belt tension is not correct.	See "Checking Tail Drive Belt Tension" in this manual
Helicopter will not lift off	Main rotor head is not spinning in the correct direction	Make sure the main rotor head is spinning clockwise. Refer to motor control test
	Transmitter settings are not correct	Check throttle and pitch curve settings
	Flight battery has low voltage	Fully charge the flight battery
	Main rotor blades are installed backwards	Install the main rotor blades with the thicker side as the leading edge

Blade 300 X Troubleshooting Guide, continued

Problem	Possible Cause	Solution
Flight battery will not charge	Input voltage to the charger is too low	Input voltage must be between 11.5–15V DC with a minimum 3A current
	The battery balance tab is damaged	Make sure the balance tab wires are fully seated in the balance plug
	The flight battery is overdischarged	If any cell voltage drops below 3V, the battery is damaged and must be replaced.
The helicopter tail spins out of control	Rudder control and/or sensor direction reversed	Make sure the rudder control and the rudder sensor are operating in the correct direction
	Tail servo is damaged	Check the rudder servo for damage and replace if necessary
	Inadequate control arm throw	Check the rudder control arm for adequate travel and adjust if necessary
	Tail belt is too loose	Make sure the tail drive belt tension is adjusted correctly
The helicopter wobbles in flight	Cyclic gain is too high	Decrease Dial 1 on the AR7200BX
	Head speed is too low	Increase the helicopter's head speed via your transmitter settings and/or using a freshly charged flight pack
	Dampers are worn	Replace the main rotor head dampers

Limited Warranty

What this Warranty Covers

Horizon Hobby, Inc. ("Horizon") warrants to the original purchaser that the product purchased (the "Product") will be free from defects in materials and workmanship at the date of purchase.

What is Not Covered

This warranty is not transferable and does not cover (i) cosmetic damage, (ii) damage due to acts of God, accident, misuse, abuse, negligence, commercial use, or due to improper use, installation, operation or maintenance, (iii) modification of or to any part of the Product, (iv) attempted service by anyone other than a Horizon Hobby authorized service center, or (v) Products not purchased from an authorized Horizon dealer.

OTHER THAN THE EXPRESS WARRANTY ABOVE, HORIZON MAKES NO OTHER WARRANTY OR REPRESENTATION, AND HEREBY DISCLAIMS ANY AND ALL IMPLIED WARRANTIES, INCLUDING, WITHOUT LIMITATION, THE IMPLIED WARRANTIES OF NON-INFRINGEMENT, MERCHANTABILITY AND FITNESS FOR A PARTICULAR PURPOSE. THE PURCHASER ACKNOWLEDGES THAT THEY ALONE HAVE DETERMINED THAT THE PRODUCT WILL SUITABLY MEET THE REQUIREMENTS OF THE PURCHASER'S INTENDED USE.

Purchaser's Remedy

Horizon's sole obligation and purchaser's sole and exclusive remedy shall be that Horizon will, at its option, either (i) service, or (ii) replace, any Product determined by Horizon to be defective. Horizon reserves the right to inspect any and all Product(s) involved in a warranty claim. Service or replacement decisions are at the sole discretion of Horizon. Proof of purchase is required for all warranty claims. SERVICE OR REPLACEMENT AS PROVIDED UNDER THIS WARRANTY IS THE PURCHASER'S SOLE AND EXCLUSIVE REMEDY.

Limitation of Liability

HORIZON SHALL NOT BE LIABLE FOR SPECIAL, INDIRECT, INCIDENTAL OR CONSEQUENTIAL DAMAGES, LOSS OF PROFITS OR PRODUCTION OR COMMERCIAL LOSS IN ANY WAY, REGARDLESS OF WHETHER SUCH CLAIM IS BASED IN CONTRACT, WARRANTY, TORT, NEGLIGENCE, STRICT LIABILITY OR ANY OTHER THEORY OF LIABILITY, EVEN IF HORIZON HAS BEEN ADVISED OF THE POSSIBILITY OF SUCH DAMAGES. Further, in no event shall the liability of Horizon exceed the individual price of the Product on which liability is asserted. As Horizon has no control over use, setup, final assembly, modification or misuse, no liability shall be assumed nor accepted for any resulting damage or injury. By the act of use, setup or assembly, the user accepts all resulting liability. If you as the purchaser or user are not prepared to accept the liability associated with the use of the Product, purchaser is advised to return the Product immediately in new and unused condition to the place of purchase.

Law

These terms are governed by Illinois law (without regard to conflict of law principals). This warranty gives you specific legal rights, and you may also have other rights which vary from state to state. Horizon reserves the right to change or modify this warranty at any time without notice.

WARRANTY SERVICES

Questions, Assistance, and Services

Your local hobby store and/or place of purchase cannot provide warranty support or service. Once assembly, setup or use of the Product has been started, you must contact your local distributor or Horizon directly. This will enable Horizon to better answer your questions and service you in the event that you may need any assistance. For questions or assistance, please direct your email to productsupport@horizonhobby.com, or call 877.504.0233 toll free to speak to a Product Support representative. You may also find information on our website at www.horizonhobby.com.

Inspection or Services

If this Product needs to be inspected or serviced, please use the Horizon Online Service Request submission process found on our website or call Horizon to obtain a Return Merchandise Authorization (RMA) number. Pack the Product securely using a shipping carton. Please note that original boxes may be included, but are not designed to withstand the rigors of shipping without additional protection. Ship via a carrier that provides tracking and insurance for lost or damaged parcels, as Horizon is not responsible for merchandise until it arrives and is accepted at our facility. An Online Service Request is available at <http://www.horizonhobby.com> under the Support tab. If you do not have internet access, please contact Horizon Product Support to obtain a RMA number along with instructions for submitting your product for service. When calling Horizon, you will be asked to provide your complete name, street address, email address and phone number where you can be reached during business hours. When sending product into Horizon, please include your RMA number, a list of the included items, and a brief summary of the problem. A copy of your original sales receipt must be included for warranty consideration. Be sure your name, address, and RMA number are clearly written on the outside of the shipping carton.

NOTICE: Do not ship LiPo batteries to Horizon. If you have any issue with a LiPo battery, please contact the appropriate Horizon Product Support office.

Warranty Requirements

For Warranty consideration, you must include your original sales receipt verifying the proof-of-purchase date. Provided warranty conditions have been met, your Product will be serviced or replaced free of charge. Service or replacement decisions are at the sole discretion of Horizon.

Non-Warranty Service

Should your service not be covered by warranty service will be completed and payment will be required without notification or estimate of the expense unless the expense exceeds 50% of the retail purchase cost. By submitting the item for service you are agreeing to payment of the service without notification. Service estimates are available upon request. You must include this request with your item submitted for service. Non-warranty service estimates will be billed a minimum of ½ hour of labor. In addition you will be billed for return freight. Horizon accepts money orders and cashiers checks, as well as Visa, MasterCard, American Express, and Discover cards. By submitting any item to Horizon for service, you are agreeing to Horizon's Terms and Conditions found on our website <http://www.horizonhobby.com/Service/Request/>.

Warranty and Service Contact Information

Country of Purchase	Horizon Hobby	Address	Phone Number / Email Address
United States of America	Horizon Service Center (Electronics and engines)	4105 Fieldstone Rd Champaign, Illinois, 61822 USA	877-504-0233 Online Repair Request visit: www.horizonhobby.com/service
	Horizon Product Support (All other products)	4105 Fieldstone Rd Champaign, Illinois, 61822 USA	877-504-0233 productsupport@horizonhobby.com
United Kingdom	Horizon Hobby Limited	Units 1-4 Ployters Rd Staple Tye Harlow, Essex, CM18 7NS, United Kingdom	+44 (0) 1279 641 097 sales@horizonhobby.co.uk
Germany	Horizon Technischer Service	Christian-Junge-Straße 1 25337 Elmshorn, Germany	+49 (0) 4121 2655 100 service@horizonhobby.de
France	Horizon Hobby SAS	14 Rue Gustave Eiffel Zone d'Activité du Réveil Matin 91230 Montgeron	+33 (0) 1 60 47 44 70 infofrance@horizonhobby.com
China	Horizon Hobby – China	Room 506, No. 97 Changshou Rd. Shanghai, China 200060	+86 (021) 5180 9868 info@horizonhobby.com.cn

Customer Service Information

Country of Purchase	Horizon Hobby	Address	Phone Number / Email Address
United States	Sales	4105 Fieldstone Rd Champaign, Illinois, 61822 USA	(800) 338-4639 sales@horizonhobby.com
United Kingdom	Horizon Hobby Limited	Units 1-4 Ployters Rd Staple Tye Harlow, Essex, CM18 7NS, United Kingdom	+44 (0) 1279 641 097 sales@horizonhobby.co.uk
Germany	Horizon Hobby GmbH	Christian-Junge-Straße 1 25337 Elmshorn, Germany	+49 4121 46199 60 service@horizonhobby.de
France	Horizon Hobby SAS	14 Rue Gustave Eiffel Zone d'Activité du Réveil Matin 91230 Montgeron	+33 (0) 1 60 47 44 70 infofrance@horizonhobby.com
China	Horizon Hobby – China	Room 506, No. 97 Changshou Rd. Shanghai, China 200060	+86 (021) 5180 9868 info@horizonhobby.com.cn

Compliance Information for the European Union

Declaration of Conformity

(in accordance with ISO/IEC 17050-1)

No. HH2011111303



Product(s): Blade 300 X BNF
Item Number(s): BLH4580
Equipment class: 1

The object of declaration described above is in conformity with the requirements of the specifications listed below, following the provisions of the European R&TTE directive 1999/5/EC and EMC Directive 2004/108/EC

EN 301 489-1 V1.7.1: 2006

EN 301 489-17 V1.3.2: 2008

EN55022: 2010

EN55024: 2010

Signed for and on behalf of:

Horizon Hobby, Inc.
Champaign, IL USA
November 13, 2011

Steven A. Hall
Vice President

International Operations and Risk Management
Horizon Hobby, Inc.

Instructions for disposal of WEEE by users in the European Union



This product must not be disposed of with other waste. Instead, it is the user's responsibility to dispose of their waste equipment by handing it over to a designated collection point for the recycling of waste electrical and electronic equipment. The separate collection and recycling of your waste equipment at the time of disposal will help to conserve natural resources and ensure that it is recycled in a manner that protects human health and the environment. For more information about where you can drop off your waste equipment for recycling, please contact your local city office, your household waste disposal service or where you purchased the product.

Parts List / Ersatzteile / Pièces de rechange / Pezzi di ricambio

#	Part #	English	Deutsch	Français	Italiano
1	BLH4501	245mm Wood Main Rotor Blade Set: 300 X	245mm Hauptrotorblätter Holz Set: 300 X	300 X -Paire de pales principales en bois 245mm.	Set pale rotore principale in legno 245mm: 300 X
2	BLH4502	Main Rotor Blade Grips: 300 X	Blatthalter:300 X	300 X -Pieds de pales	Supporti pale principali: 300 X
3	BLH4503	Main Rotor Blade Mounting Screw&Nut (2) : 300 X	Schrauben Blattgriffe: 300 X		Viti e dadi montaggio pale rotore principale (2): 300 X
4	BLH4504	Main Grip Bearing Kit: 300 X	Lagerblatthalter: 300 X	300 X -kit de roulements de pieds de pales.	Kit cuscinetti supporti pale: 300 X
5	BLH4505	Dampers (4): 300 X	Dämpfer (4) :300 X	300 X -Amortisseurs (4)	Ammortizzatori (4): 300 X
6	BLH4506	Spindle/Feathering Shaft(2): 300 X	Spindel u. Blattlagerwelle: 300 X		Alberino portapale (2): 300 X
7	BLH4507	Head Block/Rotor Housing Set: 300 X	Rotorkopfzentralstück: 300 X	300 X -Moyeu de tête rotor	Set blocco testa rotore: 300 X
8	BLH4508	FBL Follower Arms: 300 X	FBL Taumelscheibenmitnehmer: 300 X	300 X -Bras FBL	Braccetti follower FBL: 300 X
9	BLH4509	FBL Linkage Set: 300 X	FBL Gestängeset: 300 X	300 X -Tringleries FBL	Set collegamenti FBL: 300 X
10	BLH4510	Aluminum and Composite Swashplate: 300 X	Aluminium Composite Taumelscheibe: 300 X	300 X -Plateau cyclique en aluminium et composite	Piatto oscillante alluminio e composito: 300 X
11	BLH4511	Main Shaft (2): 300 X	Hauptrotorwelle (2) 300 X	300 X -Axe principal (2)	Albero principale (2): 300 X
12	BLH1651	Main Gear (2): B450/X, 300 X	Zahnrad (2) B450/X, 300 X	300 X/B450/X -Couronne principale (2)	Ingranaggio principale (2): B450/X, 300 X
13	BLH4513	Main tail Drive Gear (2): 300 X	Hauptzahnrad Heckrotor (2) 300 X	300 X -Pignon d'entraînement d'anticouple (2)	Ingranaggio coda (2): 300 X
14	BLH4514	Main Gear Hub: 300 X	Hauptzahnrad: 300 X	300 X -Moyeu de couronne principale	Mozzo ingranaggio principale: 300 X
15	BLH4515	Bearings 4x8x3 (3): 300 X	Kugellager 4x8x3 (3): 300 X	300 X -roulements 4X8X3 (3)	Cuscinetti 4x8x3 (3): 300 X
16	BLH4516	Aluminum Motor Mount Set: 300 X	Aluminium Motorträger Set: 300 X	300 X -Support moteur en aluminium	Set supporto motore alluminio: 300 X
17	BLH4517	Canopy Mounts (2): 300 X	Kabinenhaubehalter (2):300 X	300 X -Support de bulle	Supporti capottina (2): 300 X
18	BLH4518	Anti-Rotation Bracket/Guide: 300 X	Taumelscheibenführung: 300 X	300 X -Guide de plateau cyclique	Guida/staffa antirotazione: 300 X
19	BLH4519	Servo Arm Set: 300 X	Servo Arm Set: 300 X	300 X -Set de bras de servo	Set squadrette servo: 300 X
20	BLH4520	Landing Gear Set: 300 X	Kufengestell: 300 X	300 X -Train d'atterrissage	Set carrello atterraggio: 300 X
21	BLH4521	Belt Guide Cross Member Set: 300 X	Kreuzriemenhalter : 300 X	300 X -Guide de courroie	Set guida cinghia: 300 X
22	BLH4522	Main Frame Set: 300 X	Rahmen:300 X	300 X -Châssis	Set telaio principale: 300 X
23	BLH4523	Tail Drive Belt: 300 X (<i>not shown</i>)	Heckrotorriemen: 300 X (<i>nicht abgebildet</i>)	300 X -Courroie (<i>non illustrée</i>)	Cinghia trasmissione coda: 300 X (<i>non illustré</i>)
24	BLH4524	Servo Pushrod Set: B300 X	Servogestänge: B300 X	300 X -Tringleries de servo	Set astine di comando per servi: B300 X
25	BLH4525	Tail Boom Brace/Support Set: 300 X	Heckrohrhalter Set: 300 X	300 X -Renfort de tube de queue	Set supporto tubo coda: 300 X
26	BLH4526	Tail Booms (2): 300 X	Heckrohr (2) 300 X	300 X -Tube de queue (2)	Tubo coda (2): 300 X
27	BLH4527	Tail Pushrod Support/Guide Set: 300 X	Heckrotorgestänge / Führung: 300 X	300 X -Guide de commande d'anticouple	Set guida/supporto comando coda: 300 X
28	BLH4528	Tail Servo Boom Mount (2): 300 X	Heckrotorservohalter (2):300 X	300 X -Support de servo d'anticouple (2)	Supporto servo coda (2): 300 X
29	BLH4529	Tail Linkage/Pushrod (2): 300 X	Heckrotorgestänge (2) 300 X	300 X -Tringlerie d'anticouple (2)	Astina comando coda (2): 300 X
30	BLH4530	Stabilizer/Fin Set, White: 300 X	Halter f. Stabilisator Finne Set:300 X	300 X -Stabilisateur et dérive, blanc	Set impennaggio verticale, bianco: 300 X
31	BLH4531	Horizontal Stabilier/Fin Mount: 300 X	Halter Stabilisator/ Finne: 300 X	300 X -Support de dérive et stabilisateur	Supporto stabilizzatore orizzontale: 300 X
32	BLH4532	Tail Case: 300 X	Heckrotorgehäuse:300 X	300 X -Carter d'anticouple	Scatola coda: 300 X
33	BLH4533	Tail Rotor Pitch Lever Set: 300 X	Umlenkhebel f. Heckrotorpitchhülse:300 X	300 X -Levier de pas d'anticouple	Set leva passo rotore coda: 300 X
34	BLH4534	Bearings 3x7x3 (2): 300 X	Kugellager 3x7x3 (2): 300 X	300 X -Roulements 3X7X3 (2)	Cuscinetti 3x7x3 (2): 300 X
35	BLH4535	Tail Rotor Shaft and Drive Pulley (2): 300 X	Heckrotorwelle und Antriebsrad (2) 300 X	300 X -Axe d'anticouple avec poulie (2)	Alberino e puleggia rotore coda (2): 300 X
36	BLH4536	Tail Rotor Pitch Control Slider Set: 300 X	Heckrotorpitchhülse	300 X -Coulisseau d'anticouple	Set cursore passo coda: 300 X

#	Part #	English	Deutsch	Français	Italiano
37	BLH4537	Tail Rotor Blade Set: 300 X	Heckrotorblätter: 300 X	300 X -Paire de pales d'anticouple	Set pale coda: 300 X
38	BLH1670	Tail Rotor Blade Grip/Holder Set: B450, 300 X	Heckrotor Blatthalter: B450, 300 X	B450,300 X -Pieds de pales d'anticouple.	Set supporto pale rotore coda: B450, 300 X
39	BLH1612	Tail Rotor Thrust Bearings: B450, 300 X	Heckrotordrucklager: B450, 300 X	B450,300 X -Butées à billes de rotor d'anticouple	Cuscinetti reggispinta rotore coda: B450, 300 X
40	EFLH1115	Bearing 3x6x2.5mm (2): 300 X	Kugellager 3x6x2,5mm (2) 300 X	300 X -Roulement 3X6X2.5mm (2)	Cuscinetto 3x6x2.5mm (2): 300 X
41	BLH4540	Aluminum Tail Rotor Hub Set: 300 X	Aluminium Heckrotor Blatthalter Set: 300 X	300 X -Moyeu d'anticouple en aluminium	Set mozzo alluminio rotore coda: 300 X
42	BLH4541	Mini Helicopter Main Blade Holder: 300 X (not shown)	Blatthalter Hauptrotor 300 X (nicht abgebildet)	300 X -Support de pales pour mini hélicoptère (non illustré)	Supporto pale pale principali mini elicottero: 300 X (non illustrato)
43	BLH4542	Stock Canopy: 300 X	Kabinenhaube: 300 X	300 X -Bulle	Capottina stock: 300 X
44	BLH4543	Complete Hardware Set: 300 X (not shown)	Kleinteile kpl (nicht abgebildet): 300 X	300 X -Set d'accessoires	Set completo viti: 300 X (non illustrato)
45	BLH4544	Mounting Access. Screwdriver, & Wrench: 300 X (not shown)	Montage Zbh. Schraubendreher und Inbusschlüssel (nicht abgebildet) : 300 X	300 X -Accessoires de montage,tournevis et clés	Accessori e attrezzi per il montaggio: 300 X (non illustrato)
46	EFLA325HB	25-Amp Helicopter Brushless ESC: 300 X	25A Hubschrauber Brushless Regler: 300 X	300 X -Contrôleur brushless 25A	Regolatore elettronico 25 A: 300 X
47	EFLM1160H	Brushless 320 Helicopter Motor,4500Kv: 300 X	Brushless 320 Hubschrauber Motor, 4500Kv: 300 X	300 X -Moteur brushless 320, 4500Kv	Motore brushless 320, 4500Kv: 300 X
48	EFLC3115	3S 11.1V LiPo Balancing Charger, 1.8A (not shown)	3S 11,1 Volt LiPo Balancer Ladegerät 1,8A (nicht abgebildet)	Chargeur équilibreur Li-Po 11.1V 3S (non illustré)	Caricabatteria con bilanciamento 3S 11.1V LiPo, 1.8A (non illustrato)
49	EFLB 13503S30	1350mAh 3S 11.1V 30C LiPo, 13AWG EC3	1350mAh 3S 11.1V 30C LiPo, 13AWG, EC3 Stecker	Batterie Li-Po 11.1V 3S 1350mA 30C, prise EC3	Batteria LiPo 1350mAh 3S 11.1V 30C, 13AWG EC3
50	EFLRDS76	7.6-Gram Sub-Micro Digital Servo (ELE/AIL/PIT)	7.6-Gr. Sub-Micro Digital Servo (ELE/AIL/PIT)	Sub micro servo digital 7.6g (Profondeur/Aileron/pas)	Servo 7.6-Gram Sub-Micro Digital (ELE/AIL/PIT)
51	EFLRDS76T	7.6-Gram Sub-Micro Digital Servo- TR	7.6-Gr Sub-Micro Digital Servo- TR	Sub micro servo digital 7.6g (anti-couple)	Servo 7.6-Gram Sub-Micro Digital - TR
52	EFLRDS761	Gear Set: DS76 (not shown)	Getriebe Set DS76T (nicht abgebildet)	Jeu de pignons pour DS76 (non illustré)	Set ingranaggi: DS76 (non illustrato)
53	EFLRDS76T1	Gear Set: DS76T (not shown)	Getriebe Set DS76T (nicht abgebildet)	Jeu de pignons pour DS76T (non illustré)	Set ingranaggi: DS76T (non illustrato)
54	BLH1609	Pinion Gear, 9T 0.5M: B450 3D/X, B400, B300 X	Ritzel 9T 0,5M : B450 3D/X, B400, B300 X	B450 3D/X,B400, B300 X -Pignon 9 dents 0.5M	Pignone, 9T 0.5M: B450 3D/X, B400, B300 X
55	SPM AR7200BX	AR7200BX 7CH DSMX Flybarless Control System	AR7200BX 7CH DSMX Flybarless	Module AR7200BX 7voies DSMX Flybarless	Sistema di controllo Flybarless AR7200BX 7CH DSMX

Optional Parts / Optionale Bauteile / Pièces optionnelles / Parti opzionali

Part #	English	Deutsch	Français	Italiano
BLH1610*	Pinion Gear, 10T 0.5M: B450 3D/X, B400 , 300 X	Ritzel 10T 0,5M : B450 3D/X, B400, B300X	B450 3D/X,B400, B300 X -Pignon 10 dents 0.5M	Pignone, 10T 0.5M: B450 3D/X, B400, 300 X
BLH4501C	245mm CF Main Rotor Blade: 300 X, BSR	245mm Carbon Main Rotor Blade: 300 X,BSR	300X,BSR -Pales principales en carbone long 245mm	Pale rotore principale CF 245mm: 300 X, BSR
BLH4502A	Aluminum Flybarless Main Rotor Grip Set: 300 X	Aluminium Flybarless Hauptrotorblatt-thalter Set: 300X	300X -Pieds de pales principales en aluminium	Set supporti pale alluminio rotore princ. Flybarless: 300 X
BLH4507A	Aluminum Flybarless Head Block Set: 300 X	Aluminium Flybarless Rotorkopfzentralstück: 300X	300X -Moyeu de tête en aluminium	Set blocco testa alluminio Flybarless: 300 X
BLH4508A	Aluminum Flybarless Follower Arms: 300 X	Aluminium Taumelscheibenmitnehmer: 300X	300X -Bras FBL en aluminium	Braccetti alluminio follower Flybarless: 300 X
BLH4510A	Aluminum Swashplate: 300 X	Aluminium Taumelscheibe: 300X	300X -Bras FBL en aluminium	Piatto oscillante alluminio: 300 X
BLH4518A	Aluminum AntiRotation Bracket/Guide: 300 X	Aluminium Taumelscheibenführung: 300X	300X -Guide de plateau cyclique en aluminium	Guida/staffa antirotazione alluminio: 300 X
BLH4519A	Aluminum Servo Control Arms: 300 X	Aluminium Servokontrollarme: 300X	300X -Bras de servos en aluminium	Braccetti servo alluminio: 300 X
BLH4525A	Tail Boom Brace/Support Set/Aluminum: 300 X	Heckrohrhalter Set/ Aluminium: 300X	300X -Renfort de poutre en aluminium	Set supporto tubo coda alluminio: 300 X
BLH4526C	Tail Boom, Carbon Fiber: 300 X	Heckrohr Kohlefaser: 300X	300X -Tube de queue en carbone	Tubo coda in fibra di carbonio: 300 X
BLH4528A	Aluminum Tail Servo Boom Mount: 300 X	Aluminium Heckservohalter: 300X	300X -Support de servo d'anticouple en aluminium	Supporto alluminio per servo coda: 300 X
BLH4530C	Stab/Fin Set, Carbon Fiber: 300 X	Carbon Stabilisator Finne Set: 300X	300X -Dérive et stabilisateur en carbone	Set impennaggi in carbonio: 300 X
BLH4531A	Aluminum Horizontal Stab Fin Mount: 300 X	Aluminium Horizontal Stabilisator Halter: 300X	300X -Support de stabilisateur en aluminium.	Supporto in alluminio per impennaggio orizzontale: 300 X
BLH4532A	Aluminum Tail Case Set: 300 X	Aluminium Heckrotorgehäuse: 300X	300X -Carter d'anticouple en aluminium	Set scatola coda in alluminio: 300 X
BLH4533A	Aluminum Tail Rotor Pitch Lever Set: 300 X	Aluminium Heckrotorgestänge 300X	300X -Levier de pas d'anticouple en aluminium	Set leva passo rotore coda in alluminio: 300 X
BLH4535A	Tail Rotor Shaft Aluminum Drive Pulley: 300 X	Heckrotorwelle mit Antriebsrad: 300X	300X -Axe d'anticouple avec poulie en aluminium	Alberino e puleggia rotore coda in alluminio: 300 X
BLH4536A	Aluminum Tail Rotor Pitch Control Slider Set: 300 X	Aluminium Pitschiebehülse Set: 300X	300X -Coulisseau d'anticouple en aluminium	Set cursore passo coda alluminio: 300 X
BLH45370R	Tail Rotor Blade Set, Orange: 300 X	Heckrotorblätter Set Orange: 300X	300X -Pales d'anticouple, orange	Set pale coda, arancio: 300 X
BLH4537GR	Tail Rotor Blade Set, Green: 300 X	Heckrotorblätter Set Grün: 300X	300X -Pales d'anticouple,vert	Set pale coda, verde: 300 X
BLH4537YE	Tail Rotor Blade Set, Yellow: 300 X	Heckrotorblätter Set Gelb: 300X	300X -Pales d'anticouple,jaune	Set pale coda, giallo: 300 X
BLH4537C	Tail Rotor Blade Set Carbon Fiber: 300 X	Heckrotorblätter Set Kohlefaser: 300X	300X -Pales d'anticouple,carbone	Set pale coda, carbonio: 300 X
BLH1670A	Aluminum Tail Rotor Blade Grp Set Hub: B450, 300 X	Aluminium Blatthalter: B450 ,300X	B450, 300X -Pieds de pales d'anticouple en aluminium	Set supporto pale alluminio per rotore coda:B450, 300 X
BLH4542A	Black/Yellow Option Canopy	Kabinenhaube Gelb/Schwarz	Bulle optionnelle Noir/jaune	Capottina opzionale nero/giallo
BLH4542B	Red/Black Option Canopy	Kabinenhaube Rot/Schwarz	Bulle optionnelle Rouge/noir	Capottina opzionale rosso/nero
BLH4542C	Yellow/Green Option Canopy	Kabinenhaube Gelb/Grün	Bulle optionnelle Jaune/vert	Capottina opzionale giallo/verde
BLH2149	300 X Carrying Case	300 X Tragekoffer	300X -Valise de transport	Valigetta per il trasporto del 300 X
EFLC3025	Celectra 80W AC/DC Multi-Chemistry Battery Charger	Celectra 80W AC/DC Multi Akku Ladegerät	Chargeur Celectra AC/DC 80W	Caricabatterie multiplo Celectra 80W AC/DC
EFLC4030	3.0-Amp Power Supply, 100-240V AC-12V DC	3,0 A Netzgerät 100- 240V AC 12 DC	Alimentation secteur 100-240V 3A 12V DC	Alimentatore 3 A, 100-240V AC-12V DC
EFL-C4030AU	3.0 Amp Power Supply, 100-240V AC-12V DC AU	3,0 A Netzgerät 100- 240V AC 12 DC AU	Alimentation secteur 100-240V 3A 12V DC, prise AU	Alimentatore 3 A, 100-240V AC-12V DC AU
EFL-C4030EU	3.0 Amp Power Supply 100-240V AC-12V DC EU	3,0 A Netzgerät 100- 240V AC 12 DC EU	Alimentation secteur 100-240V 3A 12V DC, prise EU	Alimentatore 3 A, 100-240V AC-12V DC EU
EFL-C4030UK	3.0 Amp Power Supply, 100-240V AC-12V DC UK Plug	3,0 A Netzgerät 100- 240V AC 12 DC UK	Alimentation secteur 100-240V 3A 12V DC, prise UK	Alimentatore 3 A, 100-240V AC-12V DC spina UK
	DX8 DSMX Transmitter Only	DX8 DSMX nur Sender	Emetteur seul DX8 DSMX	Solo trasmettitore DX8 DSMX
	DX7s 7 Ch with AR8000 No SX's	DX7s 7 Kanal mit AR8000 ohne Servos	DX7s 7 voies avec AR8000, sans servo	Radio DX7s 7 Ch con AR8000 senza servi
	DX7s Transmitter Only	DX7s nur Sender	Emetteur seul DX7s	Solo trasmettitore DX7s

* If used, Carbon Blades are required

* Carbonblätter werden benötigt

* Utilisation impérative de pales carbone avec cette pièce.

* Se usato richiede le pale in carbonio.

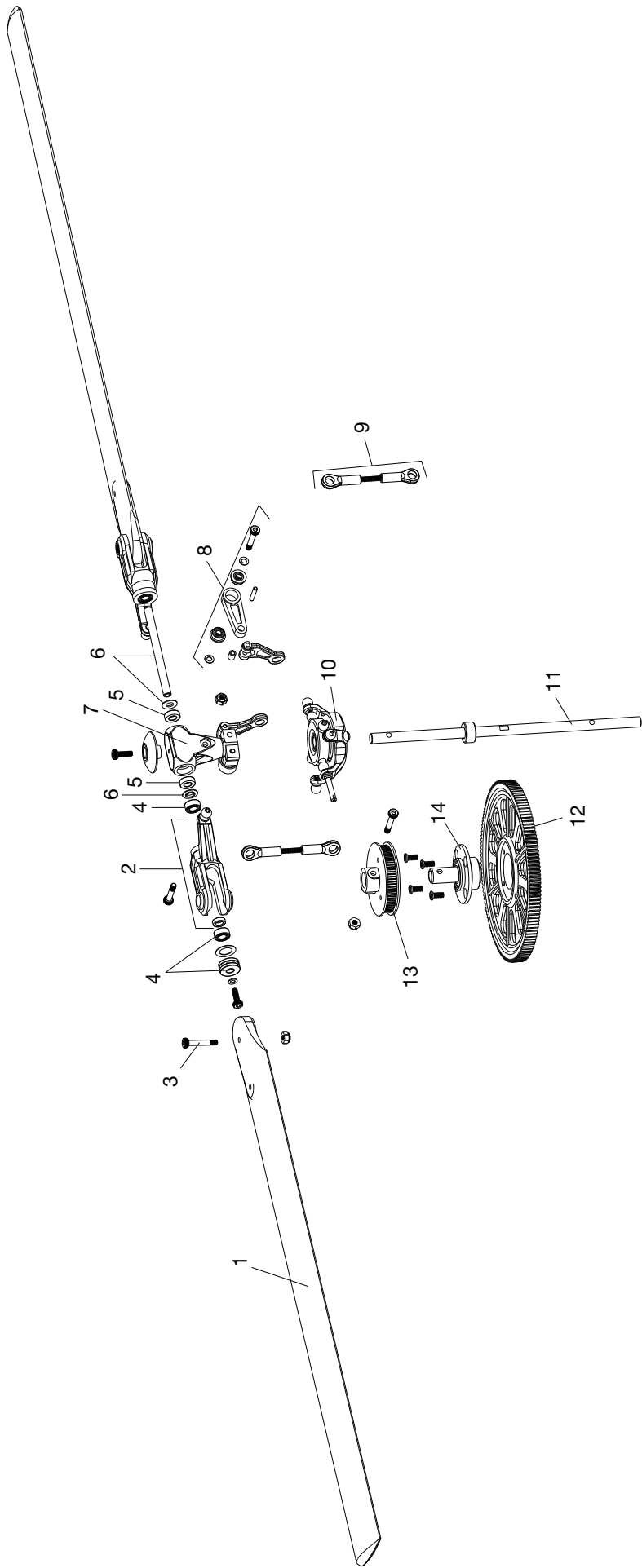

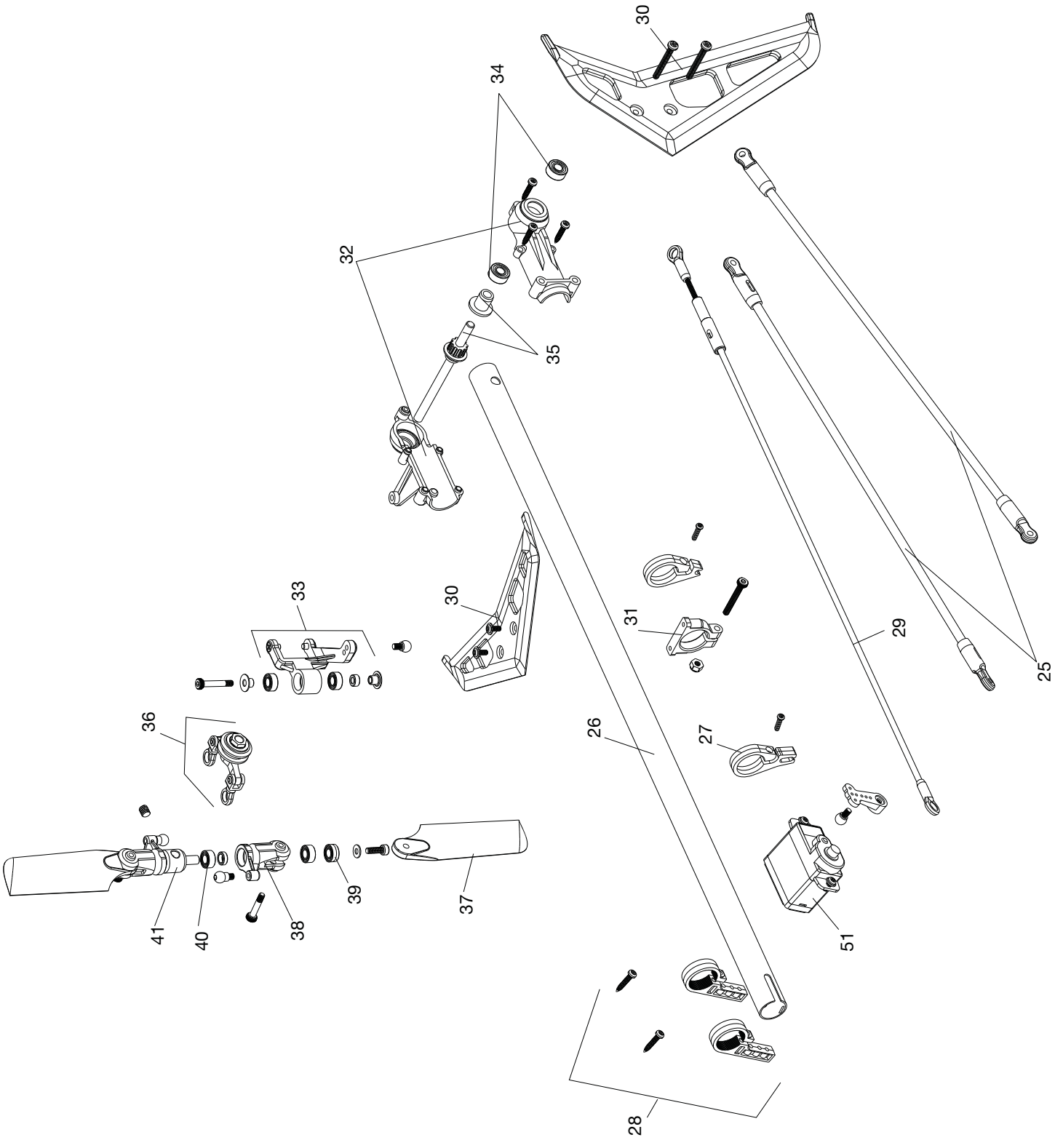

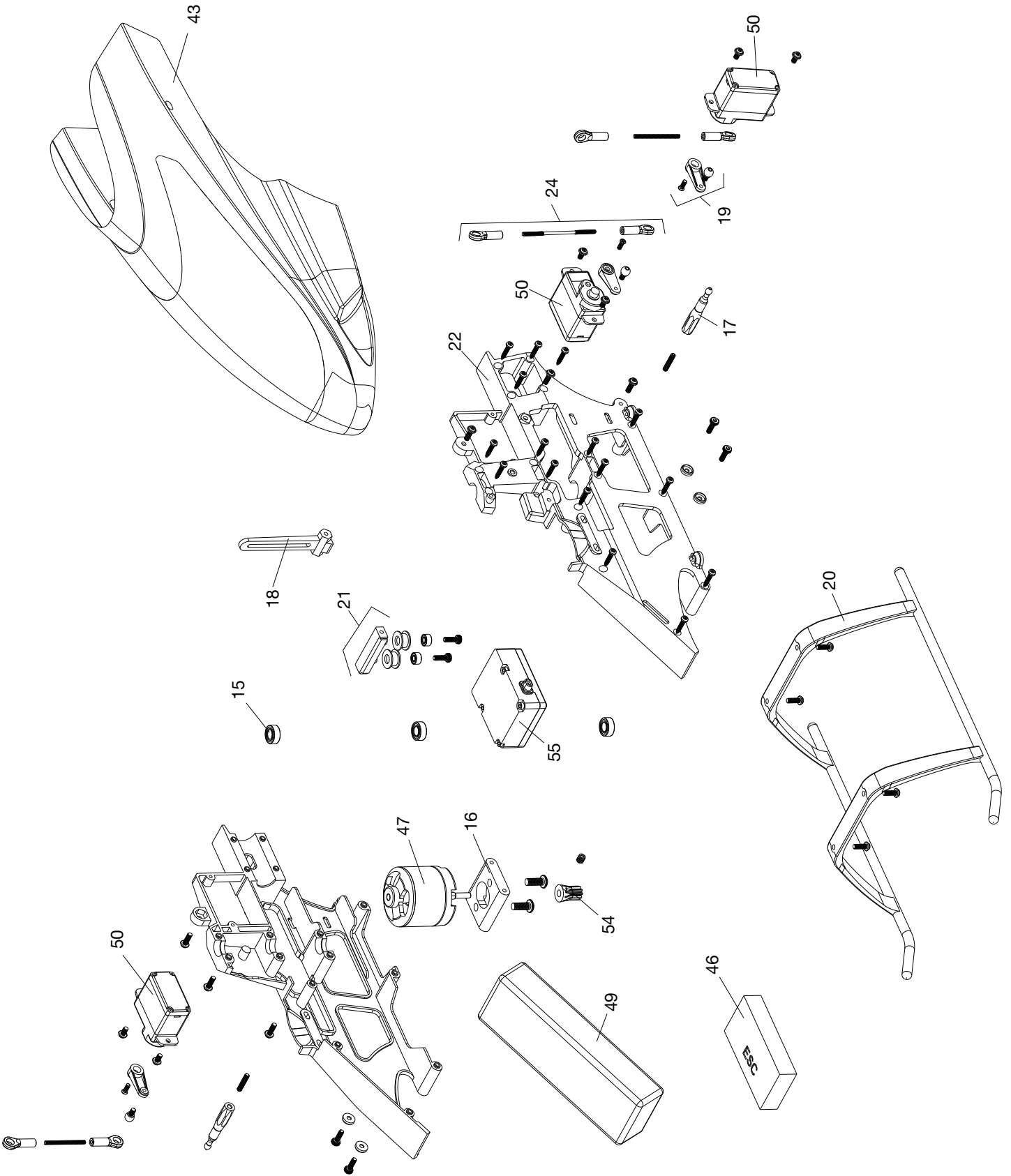

©2012 Horizon Hobby, Inc.

Blade, DSM, DSM2, ModelMatch, AirWare and EC3 are trademarks or registered trademarks of Horizon Hobby, Inc.
DSMX is a trademark of Horizon Hobby, Inc., registered in the U.S.

The Spektrum trademark is used with permission of Bachmann Industries, Inc.

BeastX is a trademark of Markus Schaack and is used with permission.

The Spektrum AR7200BX employs technology exclusively licensed to Horizon Hobby, Inc. from freakware GmbH.

Futaba is a registered trademark of Futaba Denshi Kogyo Kabushiki Kaisha Corporation of Japan

US patent number 7,391,320. Other patents pending.

Created 11/11 34512 BLH4580